

Operating a DC Electric Arc Furnace on a Weak Grid Challenges and Solutions

S. Tambe, R. Stadler, ABB Switzerland Ltd

ABSTRACT

AC and DC power supplies can be used for melting ferrous and non-ferrous metals. A DC electric arc furnace (EAF) is the natural choice for melting when network short-circuit capacity is very low or if the furnace is operated in island mode. Selecting a DC EAF for Ferro-nickel (FeNi) smelting, or similar, is possible due to the latest developments in submerged arc furnace technology.

Even if such DC furnaces are operated in constant power mode, fluctuations in current and voltage are inherent. This leads to reactive power swings that results in flicker. Active power swings can lead to unstable generation or even power supply interruptions. Although DC EAF operation is suited to weak grids, it poses various challenges to rectifier controls and generating equipment for island mode operation or for extremely weak grids.

Such challenges are overcome by using special algorithms within the rectifier controls that allows constant power operation by minimizing the step loading on generation. Electrode control which plays an important role in furnace operation, also affects the electrical performance. Adaptive controls with special signal processing need to be implemented.

A communication link between the rectifier control system and generation which monitors the frequency and adapts the load shedding can be implemented to avoid adverse effects on generating equipment.

For very weak grids or island mode operations, network frequency can be stabilized by installing static power compensator (SPC). This compensates for power swings or power perturbations resulting from furnace operation. An intelligent monitoring system can be implemented that supervises generation levels, available spinning reserve and frequency, and also connects governors and the controls for rectifier, SVC, SPC and excitation.

The objective of this development is to achieve the highest production continuity and arc stability while optimizing network performance and minimizing the effect on generating equipment, thereby providing longer life and minimum power interruptions while operating DC EAFs on weak grids or in island mode.

1 INTRODUCTION

In present economic and socio-political situations, DC EAF plants are not only planned where strong reliable grids are available, but more often in remote areas where grids are weak or practically non-existent. In this case study the furnace can be fed by a captive power plant, with or without a connection to a weak grid. This poses totally different challenges to DC power supply designers. On one side, power to a DC EAF has to be reliable (with high availability), while on the other side power generation and its limitations need to be considered.

Arc impedance variations are a stochastic phenomenon. This is more predominant in scrap melting. Nevertheless, they are also present in the case of submerged arc furnaces used in the smelting process. These furnaces are mainly operated in constant power mode, but still contain current and voltage fluctuations. Although operated in constant power mode, the network experiences large current swings, along with active and reactive power variations.

In a submerged arc system, power to the furnace and the feed rate must be coordinated. Consistency in feed materials, the feed method and feed rate dictates the required arc power. Bath power required for slag that in turn defines the temperature and fluidity of slag, is highly critical. In a DC EAF feed rate consistency, time constants of current and electrode controllers, size of DC reactors as well as hydraulic characteristics, results in power variations. Even when the furnace is operated in constant power mode, power variations are unavoidable.

An electrical system connected to a strong grid is not affected by such power variations. However, frequency variations and unwanted network oscillations are caused by operating on a weak grid or with a captive power plant that maybe connected to a weak grid. This is due to the lack of spinning power and/or inertia of the feeding system and generally a slower response to power variations. An adequately designed static Var compensator (SVC) maintains voltage stability without straining the generator's excitation system.

Extreme conditions are experienced if the arc is extinguished, the furnace trips or the DC voltage reaches zero due to short-circuit in the furnace. Such incidents cause large power dips, as the reaction time of the generators is slower than the incidents in the furnace. This results in overfrequency and/or overvoltage as the load is thrown off.

The actions taken in the generator to control the frequency and/or voltage do not allow for a fast pickup of power on the load depending on the amount of power lost and on the type and size of generator.

This, therefore, applies constraints to the process which can lead to production loss and/or process instabilities. The less generation power and inertia that are available, the higher is the aforementioned impact.

One example is that arc re-ignition can lead to a slow ramp up of the process. Ramping up the process has to be handled carefully and needs to be well coordinated between generation and load. This ensures the lowest possible production impact and avoids damaging or aging the generation equipment or disturbing other loads, internal or external, to the plant.

Should the arc get stretched or the bath/slag chemistry alter, the result is a sudden change in power demand. This leads to a variation in frequency and/or voltage.

The rectifier control system needs special algorithms to:

- help compensate for frequency and/or voltage variations
- control the loading rate on the generation in various scenarios
- avoid low frequency oscillations
- stabilize power

This paper presents various techniques which could be incorporated to avoid tripping of generators and increase the availability of the DC power supply to the EAF in order to get uninterrupted and targeted production. As a part of various measures to stabilize frequency, implementation of Static Power Compensator (SPC) is proposed.

2 TYPICAL DC POWER SUPPLY CONFIGURATION

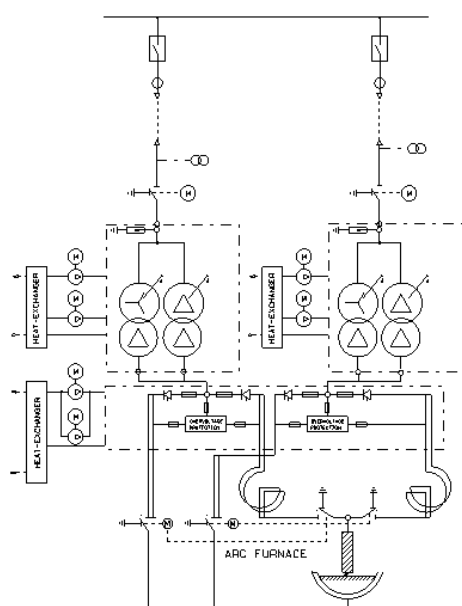

Figure 1: Basic DC power supply setup

1 INTRODUCTION

As shown in the Figure 1, the basic configuration of a DC power supply consists of switchgear, cable, rectifier transformer, rectifier, DC reactors, NoArc system with DC isolators, R_C protection on transformer, cooling system for transformers and rectifiers, and overvoltage protection for rectifiers.

Control panel functionality includes measurements, metering, protection, control, switchgear controls and other associated controls.

Communication features include communication to furnace control system or to any other supervisory system.

Hardware link is implemented between rectifier control panel and hydraulic system for electrode control.

Fibreoptic link between rectifier system and SVC system is implemented as fast forward loop for flicker reduction.

3 CHALLENGES FOR CONTINUOUS OPERATION

Constant voltage and constant frequency are the main requirements of a supply network. These two parameters are dependent on generation capacity and connected loads. In steady state, if loads are constant and generation is sufficient, then voltage and frequency remain constant. Voltage and frequency changes due to fluctuations in load, disturbances on load side as well as on generation side, are explained in greater details below:

Load side fluctuations/disturbances:

1. Switching-on rectifier transformers(in rush current)
2. Sudden tripping of furnace
3. Arc instability due to
 - a. Short-circuit between anode and charge
 - b. General arc fluctuations
 - c. Loss of arc
4. First striking of arc/ re-ignition of arc
5. Change of furnace power demand due to feed variations from conductivity changes in the slag

Supply side disturbances:

1. Grid or captive power plant losing part of its generation through, for example, heavy load fluctuations
2. Grid being disconnected and leaving only the captive power plant in operation
3. Unstable operation of generators leading to instability and tripping of synchronization when generation capacity reduces
4. Other loads causing disturbances on the grid

Power system behavior:

Power systems are designed for satisfactory operation with normal loading and defined contingencies. Excess built-in steady-state or installed capacity is limited, quite often through lack of investment. Transient capacity depends on the size, the

amount and the type of generators installed. This is valid for inertia and spinning power. Hence during overload conditions “load shed process” is adapted to avoid loss of generation, line tripping, equipment damage or a chaotic random shut-down of the network, mainly due to unsustainable under-frequency. This can lead to cascade tripping causing total blackouts.

Such outages can be due to:

1. Real power shortage (limitation on prime mover side)
2. Reactive power shortage
3. Overloads in magnitude and suddenness (random and quick occurrences)
4. Slow progressive overloads

Such overloads are detected and differentiated by various methods:

1. Frequency monitoring
2. Voltage monitoring
3. Utility SCADA (supervisory control and data acquisition) monitoring
4. Local equipment overload monitoring

Load shedding methods can be effective if system disturbances are monitored. Basic analysis may include:

1. Simple frequency decay rate analysis using initial energy reserve power, transmission line ratings, load behavior under-changing frequency and voltage, generator response (governor and turbine), minimum and maximum frequency allowed, etc.
2. A power system study is recommended to cover loss of generations, frequency analysis, active power and reactive power transfer limitations, frequency and voltage effects on loads, generator response, etc. A generator response study may cover governor response, relation with frequency of generator output, voltage regulator response, voltage-to-frequency ratio, voltage regulator overload capacity, etc. Care should be taken to see the effects on turbine life and maintenance intervals of shut down and frequency variations. Key to stability is overload detection and load shedding methods.
3. Operating DC EAF on a weak grid or in island mode is indeed a challenge. The influence on rectifier transformer and on the rectifier itself is not the main issue under discussion. Influence on network, or particularly local generating equipment, is the prime concern. Most smelting furnaces are operated with constant power control. The rectifier system receives a power and an arc resistance as reference. Software converts these values into corresponding voltage and current reference during normal operation. A special start-up sequence is implemented. In island mode operation, the objective is to maintain the load as constant as possible, thereby keeping frequency as constant as possible, maintain loading rate within specified limits and avoid oscillations which could lead to plant stoppage.

4 TYPICAL POWER SYSTEM CONFIGURATION

As shown in Fig. 2, a typical system configuration contains a network of generators, rectifier system including electrode control, a SVC system, a SPC System and a master controller. A fast forward link between the rectifier controls and the SVC as well as the SPC is foreseen. SVC takes care of reactive power compensation, flicker and harmonics injected into the network. SPC is proposed to absorb power fluctuations, which are beyond the limit of spinning power capacity, to maintain constant frequency. Dimensioning of the SPC depends upon power absorbed during normal operation as well as the eventual emergency tripping of the power supply.

5 PROPOSED SOLUTION

The following sections discuss ways to achieve continuous, stable operation. Some concepts are tested in the field while others are proposals which need to be tested by simulation and verified in actual plants.

5.1 Constant power of rectifier system

The current controller and electrode controller, used to achieve constant power control, are implemented as a basic feature. Both controllers are adaptive and performance is optimized for different melt conditions. Such adaptive controllers are implemented and tested on DC EAFs for scrap melting as well as for submerged arc applications. It is observed that reactive power fluctuations are reduced during constant power mode, compared to scrap melting with constant current mode.

In addition, slow ramps must be considered, so as not to negatively impact the generation after striking the arc and also after a partial power loss.

5.2 Feedback signal processing

Actual DC voltage is used for electrode control. Fast voltage feedback signal processing is very important, particularly when voltage changes are large and fast. It is important to avoid any delay which could cause extra loading on the generation system. The algorithm has to adapt signal processing speed, depending upon deviation of the actual voltage from the reference voltage.

5.3 Master controller

Please refer to overall configuration of master controller in Figure 2.

In a proposed configuration as shown in Fig. 2 there are many major sub-systems including:

- rectifier system for DC power supply
- SVC ArcComp system
- Static power compensator
- Grid or islanded generation and loads

There are proposed communication links between all these systems as shown in the Figure. If there is more than one furnace, a link is also proposed between the two furnace control systems.

For a steel plant System Configuration

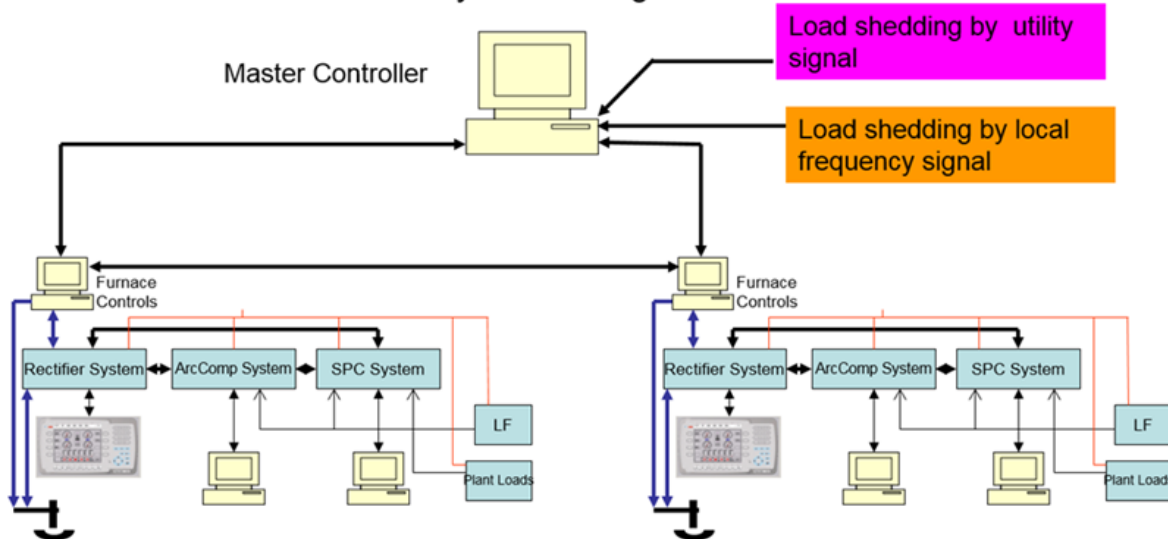

Figure 2: Typical system configuration

The master controller communicates to electrical systems via furnace control systems. The master controller has links to utilize the load shedding system as well as the local generation control systems.

The proposed communication links are good enough for slow power swings or slow changes on the generation side. Such load shedding is commonly achieved with frequency signal as well as rate of change of frequency signal.

In summary, the conventional setup with rectifier and SVC is at its limit for weak grids or captive power plants operated in island mode operation. If very fast changes in active power (MW) are present, it is recommended to use a SPC.

The main task of a master controller is to communicate to the generator system about loadings and take necessary actions to handle loads depending upon availability of the generation system.

5.4 Concept of static power compensator

Static Var compensators (SVC) have been used in plants for decades. ABB's proven ArcComp technology improves the performance compared to a conventional SVC. The SVC system maintains a constant voltage up to certain limit, depending upon the size of the SVC. Next level of action to maintain constant voltage is from excitation system in island operation.

As the SVC is intended to handle reactive power compensation, it has no possibility to compensate active power during furnace operation. Hence alternative means are necessary to stabilize active power loading on the network and hence to minimize variations in frequency.

As shown in Fig. 3, SPC is used to maintain constant active power. For example when active power swings are caused by arc dynamics must be compensated. This helps to maintain constant frequency on weak grids or island operation. SPC

sizing depends upon the power range to be compensated during normal working. If the SPC has to handle furnace trips, then sufficient short-time rating of the SPC is necessary to handle the total DC EAF power.

The SPC consists of a proven thyristor stack which is also used for SVC applications along with a resistor bank.

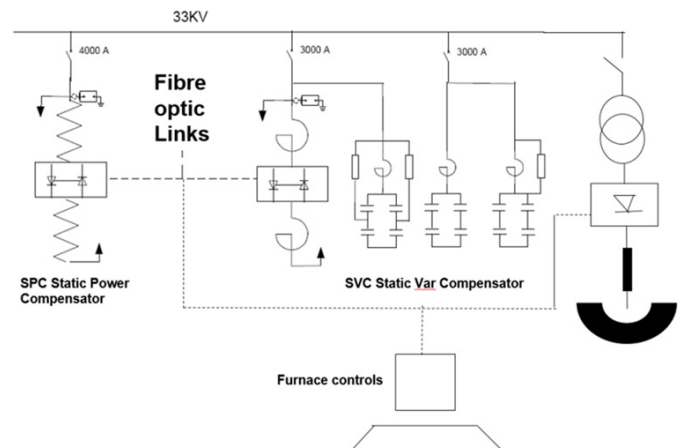

Figure 3: Typical DC power supply including SPC

4 TYPICAL POWER SYSTEM CONFIGURATION

As shown in Fig. 2, a typical system configuration contains a network of generators, rectifier system including electrode control, a SVC system, a SPC System and a master controller. A fast forward link between the rectifier controls and the SVC as well as the SPC is foreseen. SVC takes care of reactive power compensation, flicker and harmonics injected into the network. SPC is proposed to absorb power fluctuations, which are beyond the limit of spinning power capacity, to maintain constant frequency. Dimensioning of the SPC depends upon power absorbed during normal operation as well as the eventual emergency tripping of the power supply.

By stabilizing the active power (MW) loading on generation, we can expect a significant reduction in oscillations which could be generated in the local grid. This will also help to increase the life expectancy of generating equipment and maximize the production.

6 CONCLUSION

DC EAF plants installed at remote locations with weak grids or mostly operating in island mode can be operated satisfactorily without significantly compromising the life time of the generating equipment. Along with various control algorithms, static power compensator will stabilize the load to avoid frequency variations and possible instability in generation. SPC techniques will result in a continuous demand to the power supply, and thus a successful operation of the furnace and the trouble-free power generating equipment.

Uninterrupted power supply is the key to the economical viability of the plant.

7 AUTHOR'S CV

Shripad Tambe, Master of Technology, IIT Kanpur. Started career in 1977 with HBB (Hindustan Brown Boveri) India, where early responsibilities were as a senior research and development manager.

Up to 1999 worked in various technical departments including system engineering, ABB Switzerland. Inventor of two patents registered in many countries in the area of rectifiers for DC arc furnaces.

Since October 1999 to 2005, worldwide responsible for retrofit, revamp, upgrades of rectifier plants for electrolysis and arc furnaces. DGM, Systems Group and Head of Sales and Projects.

Presently, the Vice President Regional Sales, DGM Large Projects responsible for rectifier systems for aluminum and DC arc furnaces as well as SVCs for industrial applications.

Räto Stadler, Dipl. El. Ing. FH, graduated at the ZHAW in Winterthur in 1997. Started career in ABB high power rectifiers in the same year as control and commissioning engineer of rectifier systems for DC arc furnaces and aluminum smelters.

From 2001 until 2010 heading various engineering groups including mechanical and electrical engineering for DC arc furnaces, SVC systems and aluminum smelters. Inventor of various patents and utility models in the field of high-power rectifiers.

Heading global product management since 2011 for high power rectifiers and responsible for SAS1000 as a product manager.

For more information please contact:

ABB Switzerland Ltd

High Power Rectifiers

Austrasse

CH-5300 Turgi, Switzerland

Phone: +41 (0)58 589 39 39

Email: hpr@ch.abb.com

www.abb.com/rectifiers