

# Bi-directionally controlled thyristors

The bi-directional controlled thyristor (BCT) is a concept for high power phase control thyristors (PCTs) developed by ABB Switzerland Ltd., Semiconductors where two anti-parallel high power thyristors are integrated onto one single silicon wafer and are assembled into one housing. This feature enables designers of static VAR compensators, static switches, soft starters and motor drives to meet higher demands concerning size, reliability and cost for their end product. ABB has developed a BCT product matrix of 96 and 118 mm wafers and voltages from 2800 to 6500 volts.



# Contents

	Page
1 Introduction	3
1.1 BCT product matrix and short form data	3
2 BCT design 3	
2.1 BCT design criteria	4
2.2 Special BCT Features	4
2.3 Surge current behaviour of a BCT	4
2.4 Cross Talk and $t_q$	5
2.5 Quality and reliability	5
3 BCT user's guide	5
3.1 Mechanical design	5
3.2 Electrical Parameters	5
3.3 Application examples	6
3.3.1 Static VAr compensation (SVC)	6
3.3.2 Motor Drives	6
3.3.3 Soft starters	7
3.4 Advantage Summary	7
4 References	7

## 1 Introduction

The product range and the corresponding short form data are presented in Table 1. The basic product philosophy is the same as for the phase control thyristors (PCTs). Standard devices are described in data sheets, and our flexibility in the irradiation and testing process give opportunities for adapted standard devices. The wafer design, the mechanical design, the manufacturing and the testing of the bi-directional control thyristor (BCT) are based on the same technology and philosophy as for the well proven PCTs. This assures that the same high quality and reliability is achieved. The bi-directional control thyristor (BCT) family is a

strong complement to ABB's PCT family, and our increased resources in application, customer technology, rating and evaluation will assure that we can continue to support our customers' demands with an even more competitive product range.

### 1.1 BCT product matrix and short form data

The matrix in Table 1 gives an overview of the BCT family. Parameters  $I_{TAVM}$ ,  $I_{TSM}$ ,  $V_{T10}$ ,  $r_T$ ,  $R_{thJC}$  and  $R_{thCH}$  are given for one «thyristor half» of the device.

Type and ordering number	$V_{RM}$ V	$I_{RMS}^*$ A	$T_C = 70\text{ }^\circ\text{C}$		$I_{TSM}$ 10ms kA	$V_{T10}$ V	$r_T$ m $\Omega$	$T_{vjm}$ °C	$R_{thJC}$ K/kW	$R_{thCH}$ K/kW	Housing type
			$I_{TAVM}$ A	$T_{vjm}$ kA							
5STB 24Q2800	2800	5840	2630	43	0.85	0.160	125	10.0	2.0	N	
5STB 24N2800	2800	5400	2430	43	0.85	0.160	125	11.4	2.0	N	
5STB 18N4200	4200	4260	1920	32	0.96	0.285	125	11.4	2.0	N	
5STB 17N5200	5200	4000	1800	29	1.02	0.320	125	11.4	2.0	N	
5STB 13N6500	6500	3120	1405	22	1.20	0.600	125	11.4	2.0	Q	
5STB 25U5200	5200	4400	1980	42	1.06	0.219	110	8.0	1.6	U	
5STB 18U6500	6500	3510	1580	30	1.20	0.458	110	8.0	1.6	U	

Table 1: BCT product range (data sheets are available at [www.abb.com/semiconductors](http://www.abb.com/semiconductors))

\* AC full-Wave

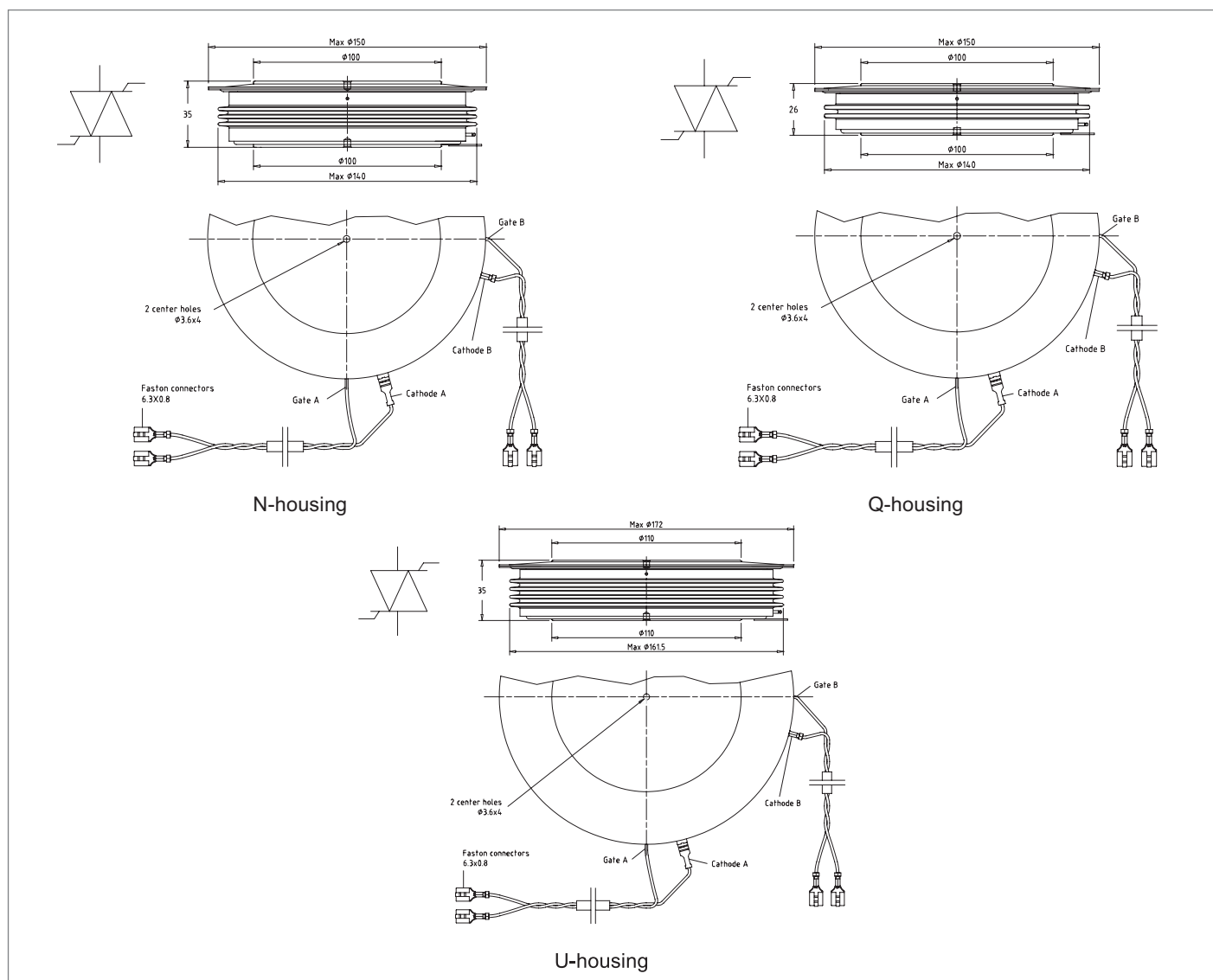

Fig. 1: Outlines

## 2 BCT design

The BCT is a unique device, bringing the customer the advantages of having two thyristors in one package: enabling more compact equipment design, simplifying the cooling system and increasing system reliability. The success of the BCT technology is based on its compatibility in process and design with ABB's well established PCT range. Reliability is guaranteed by our well proven negative bevel junction termination and free floating silicon technologies.

### 2.1 BCT design criteria

The electrical behaviour of a BCT corresponds to that of two anti-parallel thyristors integrated onto one silicon slice, (figure 2). Each thyristor-half performs like the corresponding full-wafer thyristor in respect to its static and dynamic properties.

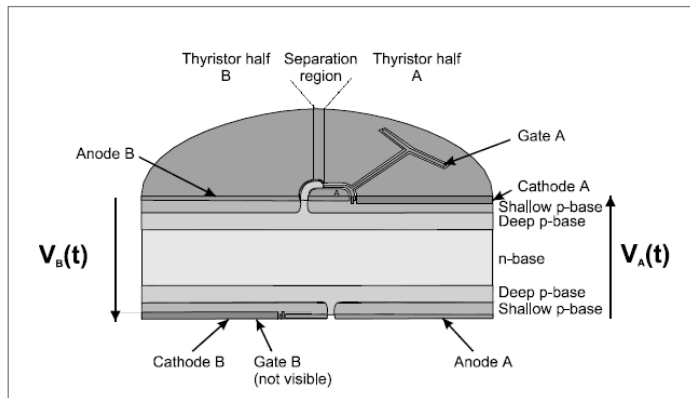

Fig. 2 Schematic cross-section of a BCT wafer showing A and B thyristor halves and defining the two forward voltage directions  $V_A(t)$  and  $V_B(t)$ . Later in the text these voltages will be labelled  $V_{D(A)}(t)$  and  $V_{D(B)}(t)$  for better clarity about forward and reverse directions.

A major challenge in the integration of the two thyristor halves is cross talk between the two halves. The photo mask set has been designed with a high focus on avoiding harmful cross talk effects under all relevant operating conditions.

Electrical performance shows very high uniformity between the two halves in device parameters such as reverse recovery charge and on-state voltage. This is demonstrated in figures 3 and 4. Figure 3 compares the spread in recovery charge ( $Q$ ) for the A thyristor-halves against the spread for the B thyristor-halves for devices tuned by electron irradiation to have a fixed on-state voltage. Figure 4 shows leakage current distributions at 4400 volts and 110 °C.

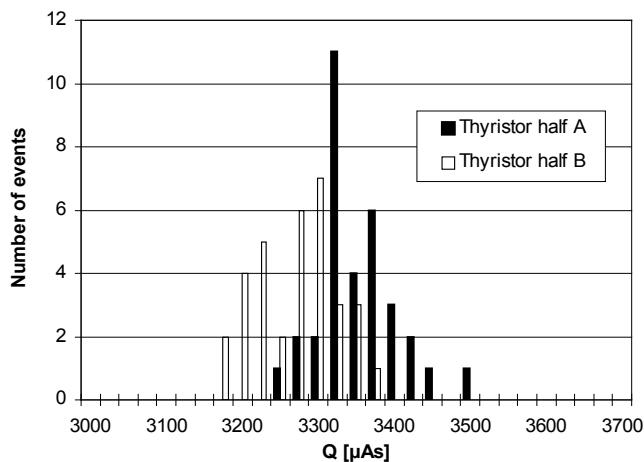

Fig. 3 Histogram of the reverse recovery charge distribution of the A and the B thyristor halves in a sample of 33 BCT devices.

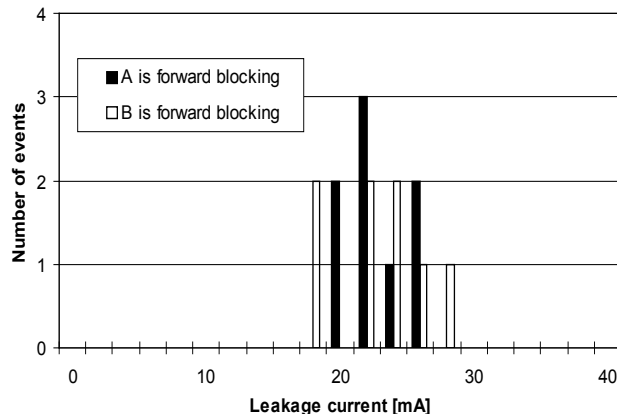

Fig. 4 Histogram of the leakage current at 4400 V and 110 °C for the A and the B thyristor halves blocking in forward direction. Sample of 8 BCT devices.

### 2.2 Special BCT Features

Under off-state blocking conditions no unique reverse direction exists, both voltage polarities correspond to forward blocking states of the A thyristor-half or the B thyristor-half respectively. This has an effect on the specification and on the parameter terminology. There is therefore no extra reverse blocking requirement as in a standard PCT.

The BCT wafer has anode and cathode regions on each face. The A and B thyristors are identified on the wafer by letters A and B on the central gate metallisation, (see figure 2). The BCT housings have been designed to correspond in size to our standard PCT range.

The cathode of the A thyristor-half faces the large flange side of the housing (the cathode side of a standard PCT element). The cathode connections to the B thyristor-half are made through the wall of the ceramic nearest the unflanged side (the anode side of the standard PCT element). Differently sized connectors to the A and B thyristor gate and cathode pairs prevent the false connection of the device during installation and maintenance. Fixed current collectors and especially machined molybdenum discs allow accurate and reliable centering of the wafer sandwich in the housing without the need for centering rings. Outlines of the housing dimensions are given in paragraph 1.

### 2.3 Surge current behaviour of a BCT

In a classical thyristor the maximum allowable surge current depends on whether reverse or forward voltage is applied after the current transient. The most critical case is forward voltage. Evidently in a BCT, a reverse voltage  $V_R$  for the A thyristor is simultaneously a forward voltage  $V_D$  for the B thyristor (fig.5) Yet it makes a difference if the re-applied voltage after a surge current pulse is positive (in forward direction) with respect to the thyristor which was formerly conducting (thyristor A for example, case 1) or positive with respect to its counterpart B which was formerly not conducting (case 2). In the situation corresponding to re-applied forward voltage for a classical thyristor (case 1), the surge current limit of a BCT is similar to the one of a classical thyristor of equal area. In the case often relevant for SVC applications, however, where a classical thyristor is exposed to reverse re-applied voltage only, i.e. case 2, a situation unique to the BCT appears, where the edge regions 1 and 2 close to the separation region are the most sensitive. The mask layout has been designed such that the separation region is strong enough to prevent failure at these sensitive regions.

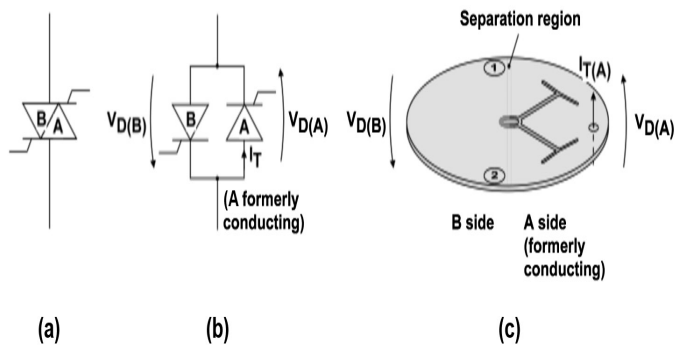

Fig. 5 Currents and voltages after turn-off of the A thyristor. (a): circuit diagram, (b): separated into two thyristors, (c): schematic view of the wafer. The regions 1 and 2 are the most sensitive in respect to surge current (with re-applied «reverse» voltage) and the  $t_q$  capability of a BCT.

## 2.4 Cross Talk and $t_q$

Again, the integration of the two thyristors on one wafer leads to a unique situation when the  $t_q$  limit is approached in the application. The reason is again that the reverse voltage used to turn the conducting thyristor-half A off is a positive voltage for its counterpart (see figure 6). The regions 1 and 2 as well as their connecting area would be the most sensitive locations. The photo mask set of the BCT has been conceived with particular attention to maintain the  $t_q$  capability of two separated thyristors.

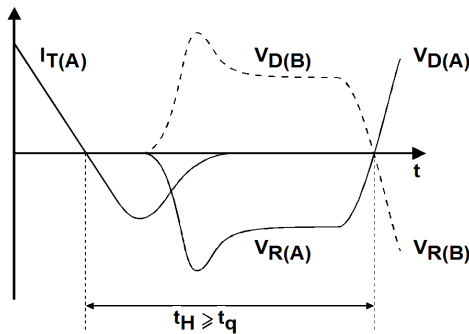

Fig. 6 Typical current and voltage waveforms after turn-off of the A thyristor. A reverse voltage for the A thyristor-half is simultaneously a forward voltage for the B thyristor-half. The holding time  $t_H$  has to be larger or equal to the recovery time  $t_q$  of the BCT.

## 2.5 Quality and reliability

Since a BCT is basically nothing more than two thyristors integrated on one wafer, most quality issues can be handled as for classical thyristors. The BCT specific parameters have been tested separately in addition to satisfy all quality requirements. From the design point of view, load cycling is expected to induce different stresses and movements in the device housing than in a classical thyristor. In our experiments, however, no perceivable difference in load cycle capability has been found. In comparison with the classical thyristor, the BCT has no need for other high-voltage blocking junction termination measures. In particular, the separation region does not carry significant lateral voltage drops; it is even short-circuited by the metallisation on both wafer sides. Therefore, the voltage blocking reliability is by design as good as that of a classical thyristor. The full characterization and approval procedure is elucidated in section 4 of the phase control thyristor data book. The procedures are equal for PCT and BCT.

## 3 BCT user's guide

The BCT is a new way of monolithically integrating two high performance PCTs on the same silicon wafer in a common housing. Consequently, the definitions and the characterising parameters of a BCT are practically almost the same as those of a PCT. Yet

there are a few exceptions which will be explained in this section. The definitions and parameters not explained in this document are described in the ABB Semiconductors PCT data book. The data book also gives application information for PCTs which is applicable to BCTs as well.

## 3.1 Mechanical design

To reduce logistical problems for both manufacturer and customer, most mechanical parts are the same for the BCT and the PCT. This brings the advantage of having the outer dimensions and the clamping forces for the BCT the same as for the standard PCT range of ABB. This enables the user to have the same mechanical clamping design for both PCT as BCT, which gives a good cost optimisation potential in applications where both PCTs and BCTs are used. One major difference exists though, and that is that the BCT has two gate and two auxiliary cathode contacts. Connecting the gate wire intended for thyristor A to that of thyristor B and vice versa will in most applications lead to destruction of one or several components. To avoid this, the cathode contact on side A has a fast-on connector of size 6.3 x 0.8 mm, while the cathode contact on side B is a fast-on connector of size 4.8 x 0.8 mm. This feature makes the mounting procedure safe, since it is not possible to connect the wrong gate wire set on either side.

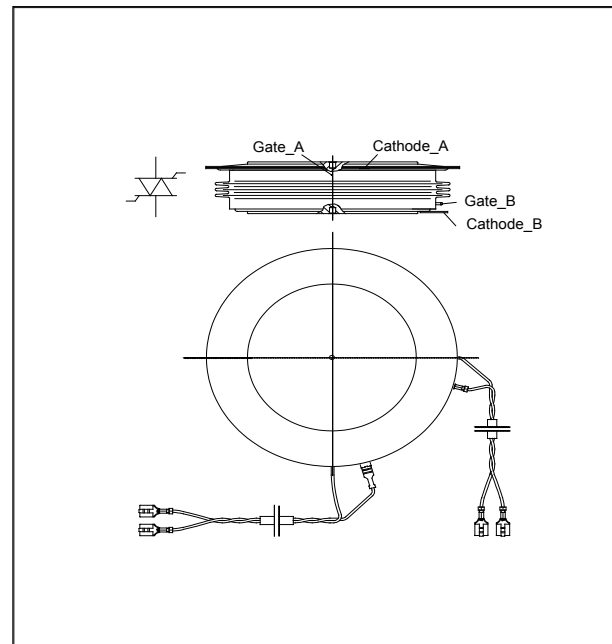

Fig. 7 BCT outline showing the gate and the cathode. At the housing wall, different connectors are used for the A and B thyristor halves to avoid incorrect connection of the gate wires.

## 3.2 Electrical Parameters

As far as the electrical parameters are concerned, the BCT data is the same as for the standard PCT range. This enables the user, for example, to utilise the same gate driver units for both types of devices.

The BCT design makes it necessary to define certain parameters in a different way to a standard PCT. The absence of a unique reverse direction makes the PCT differentiation between forward and reverse voltages obsolete. The BCT device has forward blocking voltage characteristics in both directions. The blocking voltage and current parameters necessary to specify a BCT are the following:

$V_{RM}$  is the maximum repetitive voltage level that the BCT is able to block in either direction. For details about the voltage definition see document 5SYA2049.

$I_{RM}$  specifies the maximum leakage current when  $V_{RM}$  is applied. A decrease in junction temperature will lead to a decreased leakage current.

For the definition of the parameters  $I_{TSM}$ ,  $Q$ ,  $t_q$ ,  $V_{GD}$ ,  $I_{GD}$ ,  $(di/dt)_{crit}$ ,  $(dv/dt)_{crit}$  and  $t_d$  in the data sheets, the abbreviations  $V_D$  and  $V_R$  are used.  $V_D$  is a voltage in the forward direction of the thyristor-half that will be or just has been triggered, in the case of  $t_d$ , or just has conducted current, in the case of  $Q$  and  $t_q$ . Analogously,  $V_R$  is a voltage in the reverse direction of the thyristor-half that is active for the parameter described.

The design and manufacturing technology of ABB have made it possible to produce BCTs with two thyristor functions with almost identical behaviour. For each electrical parameter, one value or one curve only is given in the data sheet. The value or curve given is valid for both thyristor functions in the BCT. One set of curves and data is sufficient for the application circuit design, and, from an electrical point of view, no particular care has to be taken in which direction the device is being mounted.

### 3.3 Application examples

The BCT has been developed as a complement to the standard PCT product range of ABB. The target was to reduce cost and thereby to increase the competitiveness of our customers in those areas where the common encapsulation of the two anti-parallel thyristors yields advantages. In this section, three application examples are given which show the advantage of using the BCT in comparison with a standard PCT solution.

One advantage common to all three examples is the increased reliability. The BCT is produced in the same manufacturing facility as our PCTs, and it uses the same basic parts, resulting in a product with the same high MTTF figure as each of our standard PCTs. Since one BCT replaces two PCTs, now, the MTTF for the whole assembly significantly improves. In addition, as can be seen in the application examples, the number of other (mechanical and electrical) parts is also reduced, so that a further increase in reliability for the whole equipment can be obtained.

#### 3.3.1 Static VAR compensation (SVC):

For efficient power transmission, the reactive power consumed by asynchronous motors or arc furnaces, for example, has to be compensated, to keep the power factor on the transmission line close to unity. One of several means to accomplish this is Static VAR Compensation. SVC has the advantage over rotating compensators in that it lacks moving parts. The components included in a SVC are capacitors, inductors and thyristor stacks. The thyristor stacks consist of a number of series-connected thyristors, which normally have additional components in parallel to them. These components serve to reduce the voltage stresses caused by the turn-off process of the thyristor and to share static and transient voltages equally between the thyristors. For the sharing of transient voltages as well as for the reduction of the turn-off over-voltage peak, a resistor and a capacitor in series are often used. The sharing of the static voltage is kept equal by placing additional resistors parallel to each thyristor. Since each stack of standard thyristors can only conduct current in one direction, two stacks have to be used in parallel for each phase of the equipment. This means that all mechanical parts needed, such as heat sinks, insulators and clamps as well as some of the electrical components have to be used for each current direction, as can be seen in figure 8. Using BCTs instead of PCTs, it is quite easy to realise from figure 8 that only one stack per phase is needed, since the current can now be controlled in both directions.

Depending on the choice of the system solution, the required number of electrical and mechanical links will be reduced by 10 - 40 percent.

This reduction has a significant impact on cost and foot print and enables the SVC manufacturer to substantially raise the competitiveness of his product.

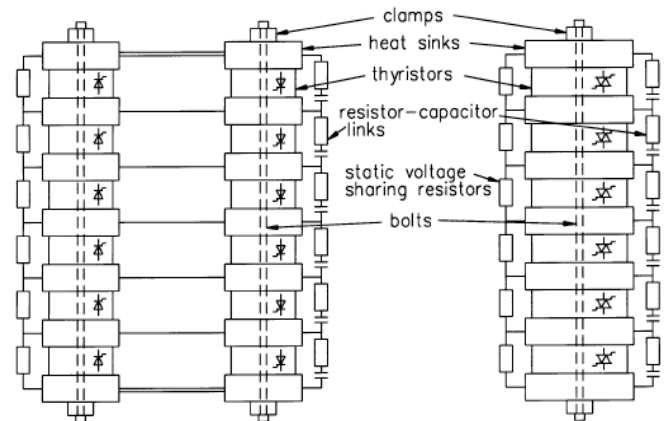

Fig. 8 Comparison between SVC thyristor stack assemblies with a conventional PCT solution at the left and a BCT solution at the right. For the stack itself, the BCT solution needs only 50 percent of the mechanical and electrical parts that are used in the PCT solution.

#### 3.3.2 Motor Drives:

To control the speed of electrical motors, an AC or DC drive is commonly used, since other means of regulating the speed have become too costly and consume too much energy. The main application areas for the BCT in drives equipment are in DC drives and in feeding sections for AC drives with return (regeneration) of energy to the power grid during braking. Another application area is that of cyclo-converters for large synchronous motors. The application example chosen in Figure 9 is a regenerative DC drive. The standard solution for a regenerative DC drive is the so-called (B6C)2 connection, which consists of two fully controlled rectifiers in anti-parallel connection. This is accomplished by using an assembly with 12 thyristors. An example of this is given in figure 9. When BCTs are utilised, a (B6C)2 bridge is built with only 6 semiconductor components. Depending on the solution used, the (B6C)2 bridge then has either a reduced height or width. The use of the BCT in this application enables a more compact solution requiring less mechanical components like heat sinks and supports. Depending on the chosen solution, this more compact solution again means a foot print reduction for a larger system, like a rolling mill line-up, by about 10 - 30 percent. This is a major cost saving, since building electrical

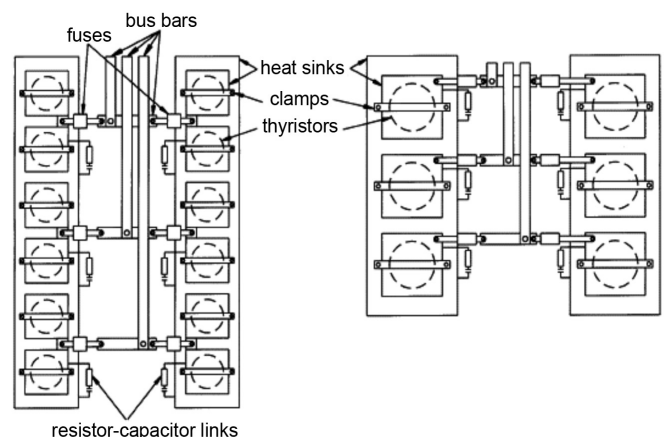

Fig. 9 Comparison between PCT and BCT assemblies for four-quadrant DC drives. The left assembly is using PCTs, and the right one is made of BCTs. The example shows the possibility of reducing height when using BCTs which enables high power DC drives to be installed in locations with height restrictions, like a harbour crane.

rooms is quite expensive. It can also enable high power drives equipment to be located in rooms with reduced height, as in a harbour crane, avoiding paralleling of low power bridges when more power is needed. This solution is drawn in figure 9. The user can normally not save on RC-circuit and fuse cost after substituting BCTs, since these components are already shared in the classical PCT solution.

### 3.3.3 Soft starters:

When starting an asynchronous machine which is directly fed from a three-phase supply net, the machine and the feeding circuit will be heavily loaded by the high starting currents. To reduce this stress, a soft starter is often used. This soft starter consists of pairs of anti-parallel thyristors having one pair per phase. As can be seen in figure 10, these anti-parallel thyristors can be directly replaced by a BCT. As for the DC drive, this substitution leads to a reduced number of mechanical parts like mounting clamps, thus enabling a more compact solution.

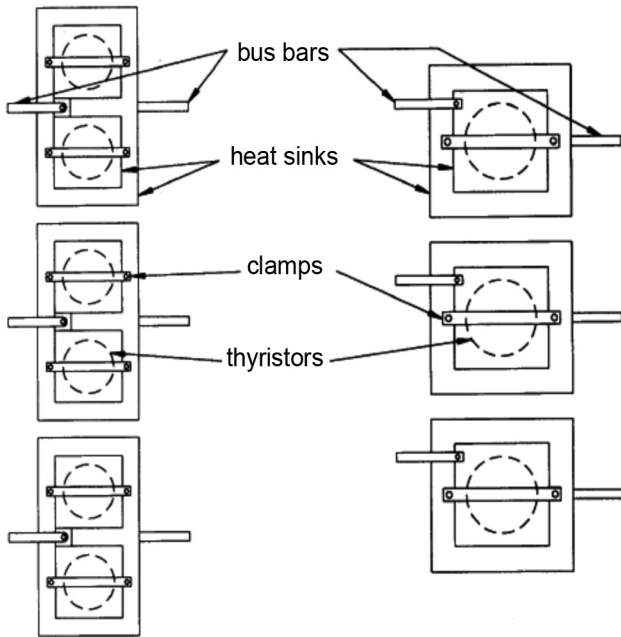

Fig. 10 Comparison of three-phase soft starter assemblies using PCTs and BCTs. The left assembly is made of PCTs, and the right one is using BCTs. The BCT solution enables a reduction in the number of required mechanical parts and therefore in size.

### 3.4 Advantage Summary

BCT designs offer considerable volume and part count reductions over conventional PCTs.

Table 2 summarises expected improvements by application and power level.

Application	Power level	Anticipated average volume improvement (*)	Anticipated average parts count reduction (*)
DC-drive	800kW	30%	30%
DC-drive	2000 kW	30%	25%
Soft starter	250 kW	25%	20%
Soft starter	450 kW	30%	20%
SVC	50 mVAr	35%	35%

Table 2 Summary of anticipated advantages when replacing a PCT solution with a BCT solution.

(\*) Compared to conventional PCT solutions.

Table 3 shows the table of replacement of PCTs by BCTs.

Replacement of PCTs by BCTs		
5STB 24Q2800	replaces two	5STP 24H2800
5STB 24N2800	replaces two	5STP 24H2800
5STB 18N4200	replaces two	5STP 18H4200
5STB 17N5200	replaces two	5STP 17H5200
5STB 13N6500	replaces two	5STP 12K6500
5STB 25U5200	replaces two	5STP 25L5200
5STB 18U6500	replaces two	5STP 18M6500

### 4 References

- 1) 5SYA2020 «Design of RC Snubbers for Phase Control Applications»
- 2) 5SYA2034 «Gate drive recommendations for phase control thyristors»
- 3) 5SYA2036 «Recommendations regarding mechanical clamping of press-pack high power semiconductors»
- 4) 5SYA2048 «Field measurements on high power press pack semiconductors»
- 5) 5SYA2049 «Voltage definitions for PCT and BCT»
- 6) 5SYA2051 «Voltage ratings of high power semiconductors»

The application notes are available at [www.abb.com/semiconductors](http://www.abb.com/semiconductors) where also chapters from the PCT data book are available.

### 5 Revision history

Version	Change	Authors
03		Björn Backlund Thomas Setz

# Contact us

## **ABB Switzerland Ltd**

### **Semiconductors**

Fabrikstrasse 3

CH-5600 Lenzburg

Switzerland

Tel: +41 58 586 14 19

Fax: +41 58 586 13 06

E-Mail: [abbsem@ch.abb.com](mailto:abbsem@ch.abb.com)

[www.abb.com/semiconductors](http://www.abb.com/semiconductors)

[m.abb.com](http://m.abb.com)

### **Note**

We reserve the right to make technical changes or to modify the contents of this document without prior notice.

We reserve all rights in this document and the information contained therein. Any reproduction or utilisation of this document or parts thereof for commercial purposes without our prior written consent is forbidden.

Any liability for use of our products contrary to the instructions in this document is excluded.