

SACE FORMULA Link

Istruzioni di installazione FORMULA Link 400
 Installation instructions for FORMULA Link 400
 Installationsanleitungen FORMULA Link 400
 Instructions d'installation FORMULA Link 400
 Instrucciones de instalación FORMULA Link 400
 连接母排安装说明书FORMULA Link 400

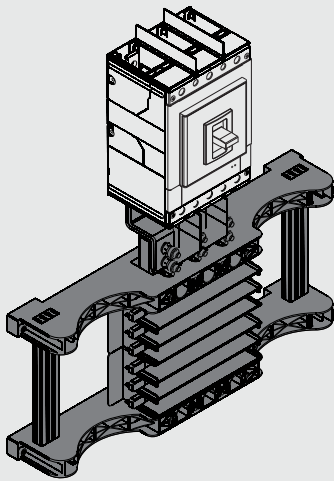

Disconnettere ogni alimentazione a monte dell'installazione e portare ogni interruttore in posizione di aperto prima di installare, modificare o eseguire manutenzioni.
 E' proibito avvicinarsi a parti in tensione prima di aver disconnesso l'alimentazione a monte.
 ABB non si assume responsabilità per danni a persone o cose derivanti dalla non applicazione o dall'incorretta applicazione delle istruzioni fornite qui e nelle istruzioni d'installazione degli interruttori.

Disconnect all power sources on the supply side of the installation and set each circuit-breaker to the open (off) position before proceeding with the installation, modification or servicing operations. Do not touch live parts without having first disconnected the power sources on the supply side. ABB declines all liability for damage to persons or things deriving from failure to comply with the instructions given here and in the installation instruction manuals of the circuit-breakers, or from incorrect application of such instructions.

Jede der Anlage vorgeschaltete Stromversorgung unterbrechen und jeden Leistungsschalter in die Aus-Stellung bringen, bevor Installationen, Änderungen oder Wartungsarbeiten ausgeführt werden. Es ist verboten, sich Spannung führenden Teilen anzunähern, bevor die Stromversorgung stromauf unterbrochen worden ist. ABB haftet nicht für Sach- oder Personenschäden infolge der Nichtanwendung oder der nicht korrekten Anwendung der Anweisungen, die hier und in den Installationsanleitungen der Leistungsschalter geliefert werden.

Débrancher chaque alimentation en amont de l'installation et placer chaque disjoncteur dans la position de ouvert avant de mettre en place, modifier ou effectuer des opérations d'entretien. Il est interdit de s'approcher des parties sous tension avant d'avoir débranché l'alimentation en amont. ABB décline toute responsabilité pour les dommages aux personnes ou aux biens dérivant de la non application ou de la mauvaise application des instructions fournies ici et dans les instructions de mise en place des disjoncteurs.

Desconectar todas las alimentaciones en entrada a la instalación y poner todos los interruptores en posición de abierto antes de efectuar instalaciones, modificaciones o trabajos de mantenimiento.
 Está prohibido acercarse a partes bajo tensión antes de haber desconectado la alimentación en entrada. ABB no se asume ninguna responsabilidad por eventuales daños a las personas o a las cosas imputables al incumplimiento o bien a una errónea implementación de las instrucciones aquí suministradas y aquellas relativas a la instalación de los interruptores.

在进行安装、更改或维修操作前，必须断开所有供电端的电源，并将每个断路器操作到断开（off）位置。在没有断开供电端电源之前，不可触摸带电的零部件。ABB不承担因不遵守本说明书和断路器安装说明书或不正确的使用而导致对人身或物体造成损伤的责任。

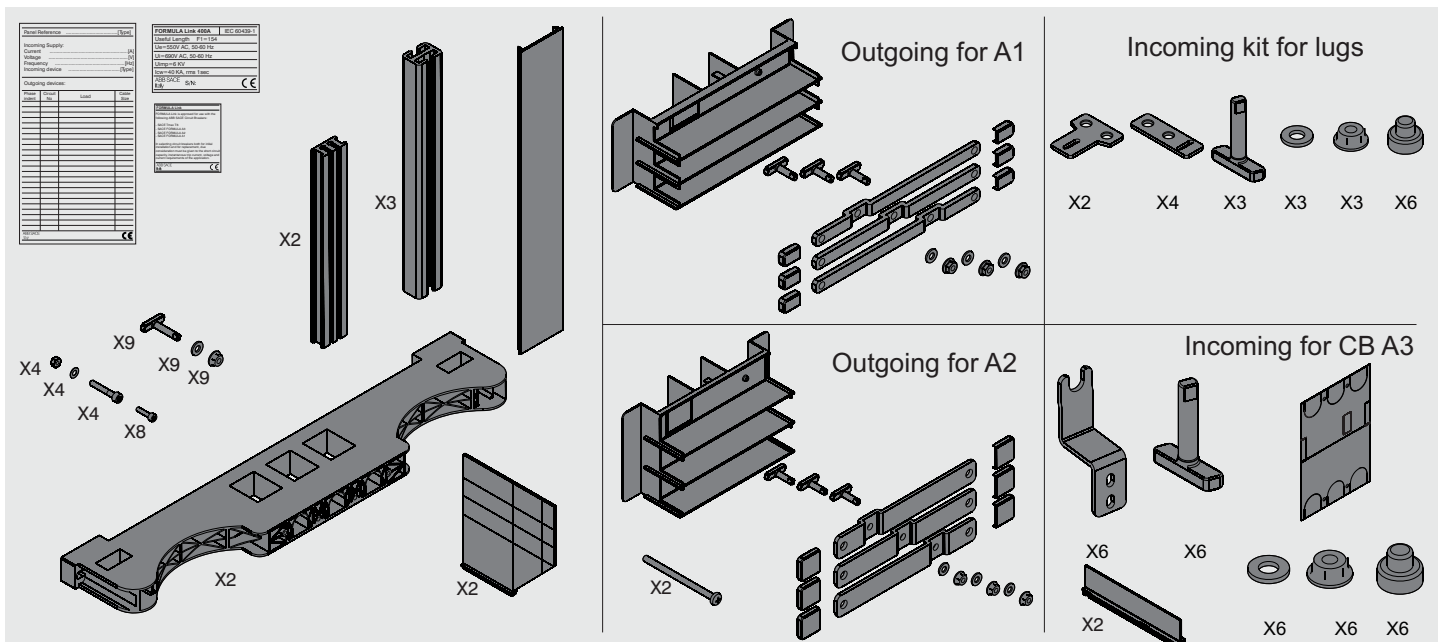

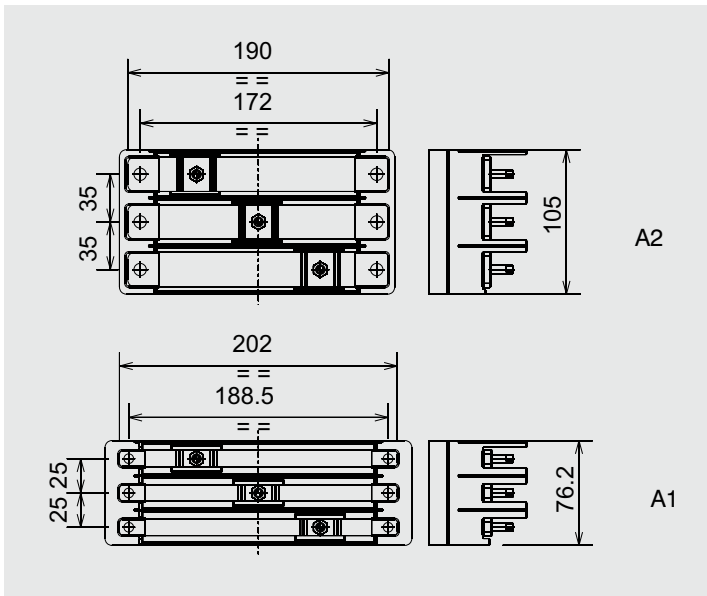
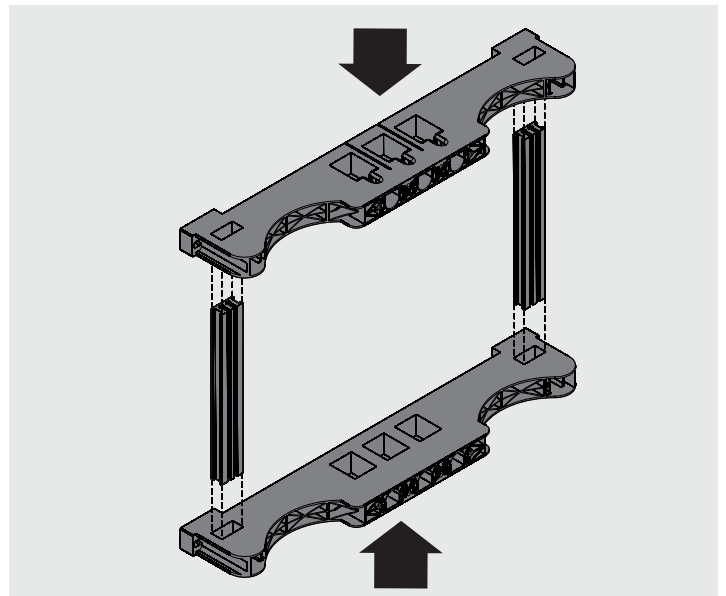
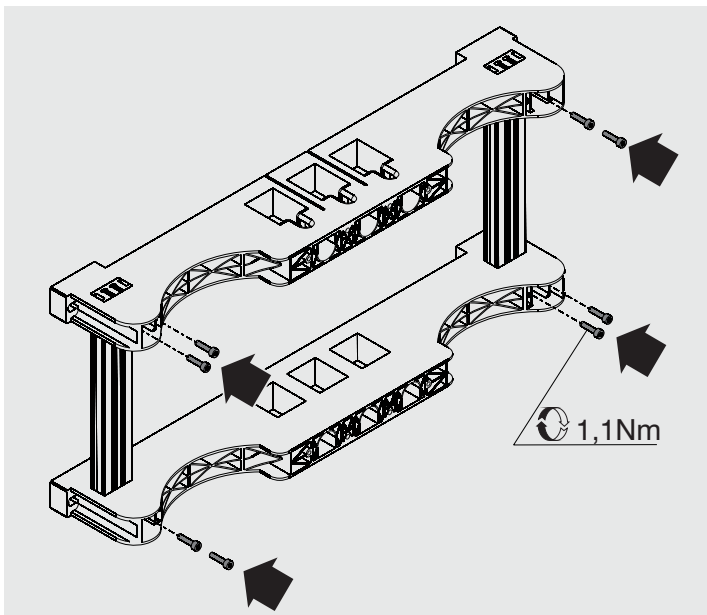
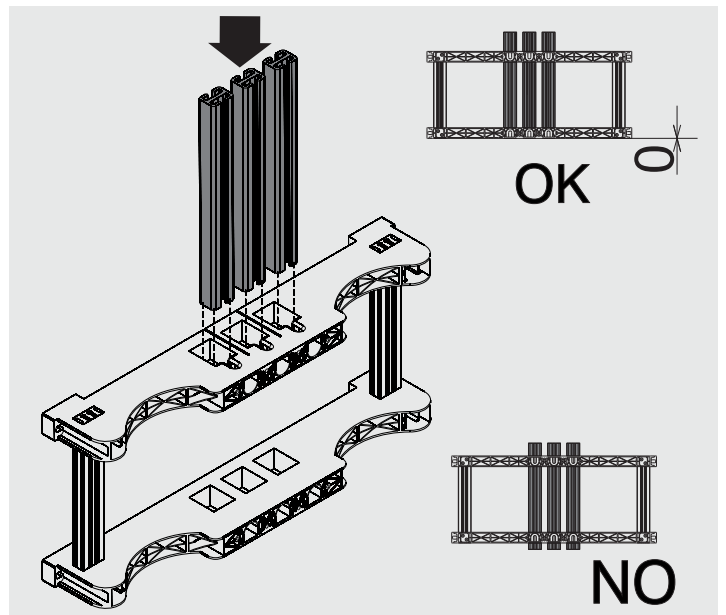
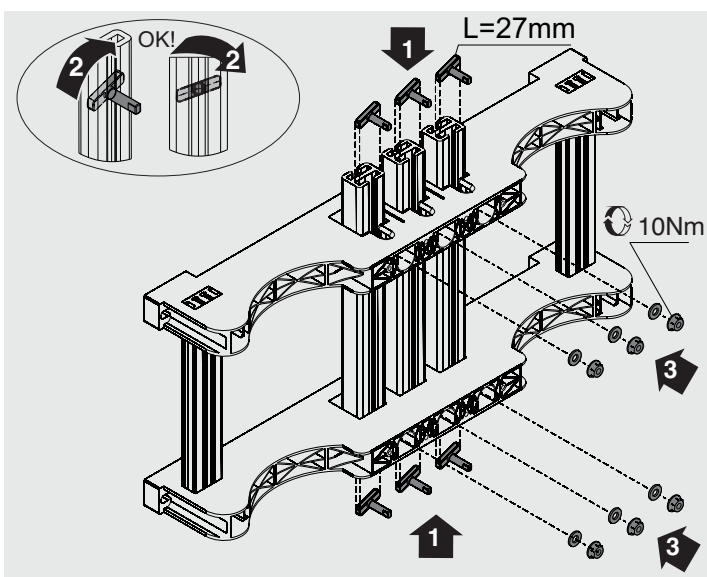
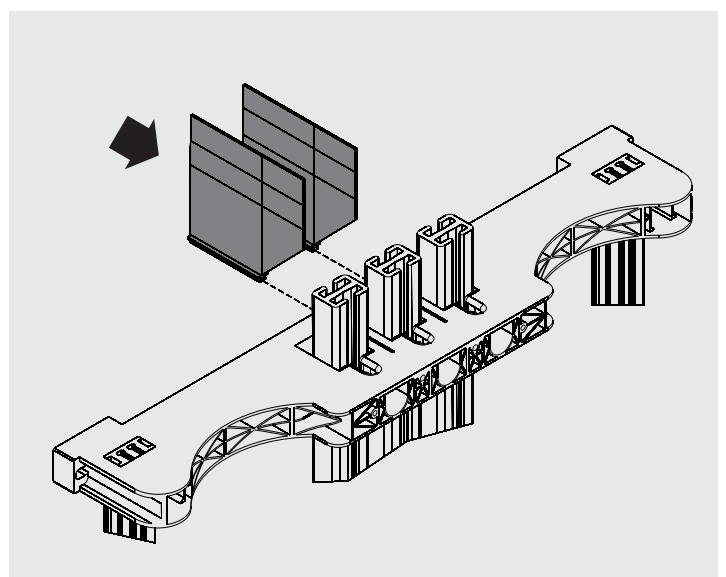
A**B****C****D****E****F**

G

Example with main CB A3

H

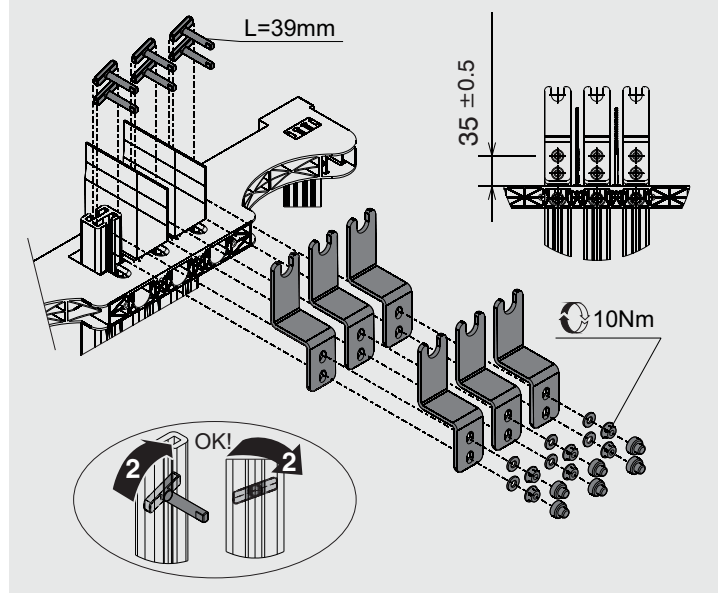
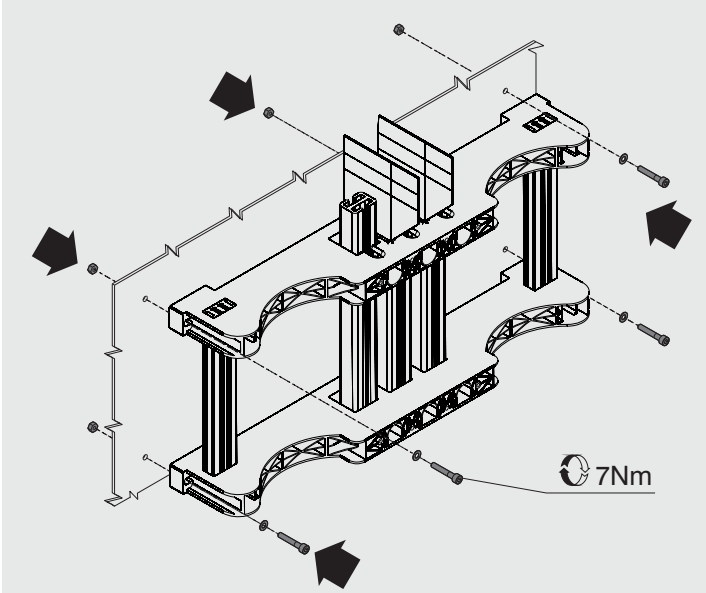

I

A cura del Cliente.
Under the Customer's responsibility.
Vom Kunden beizustellen.
À la charge du Client.
A cargo del Cliente.

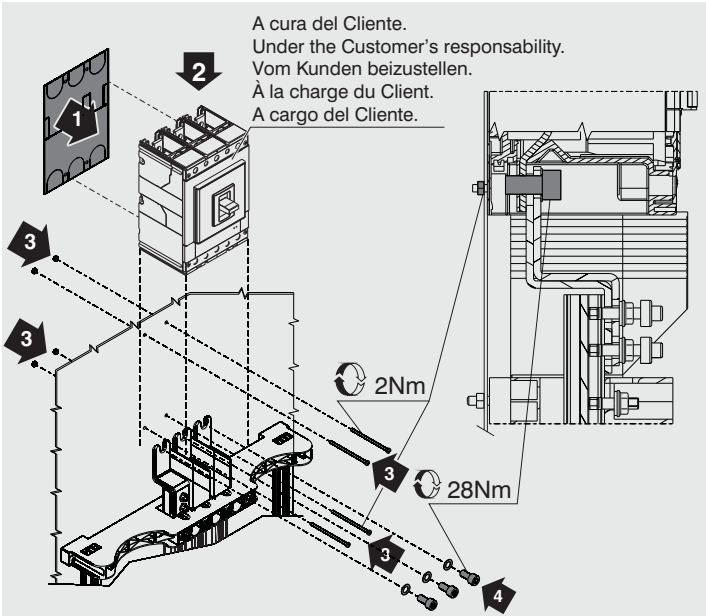

L

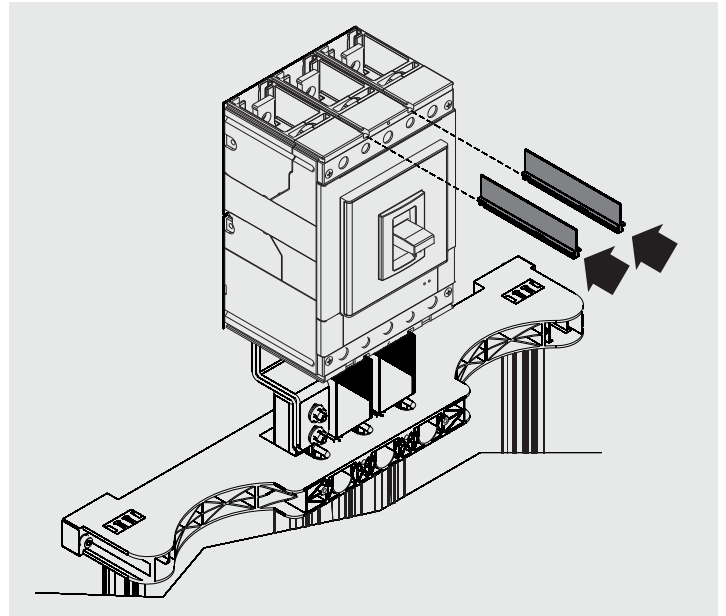

M

Example without main CB

N

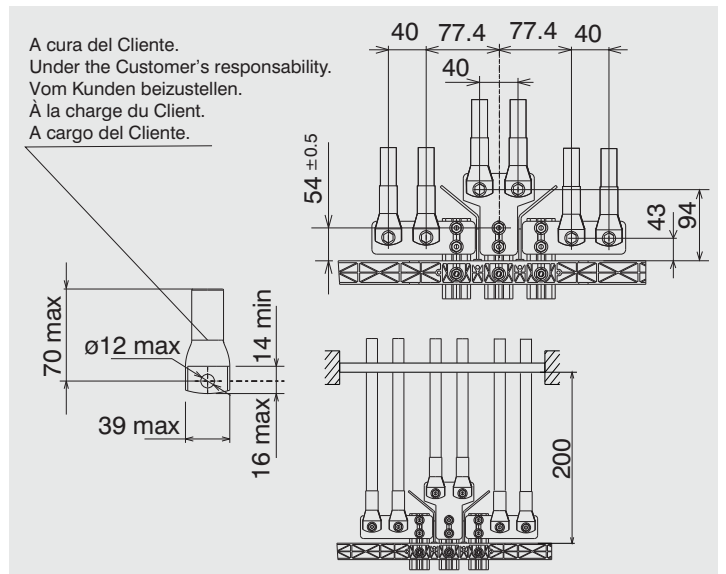
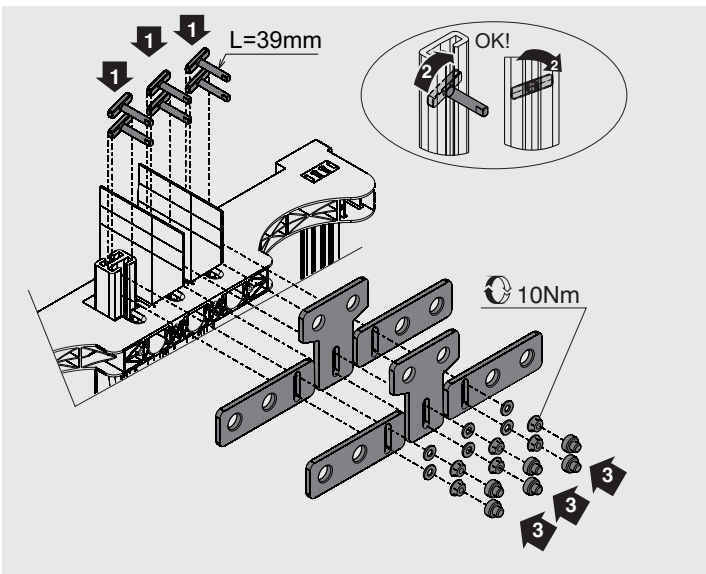

O

Example without main CB

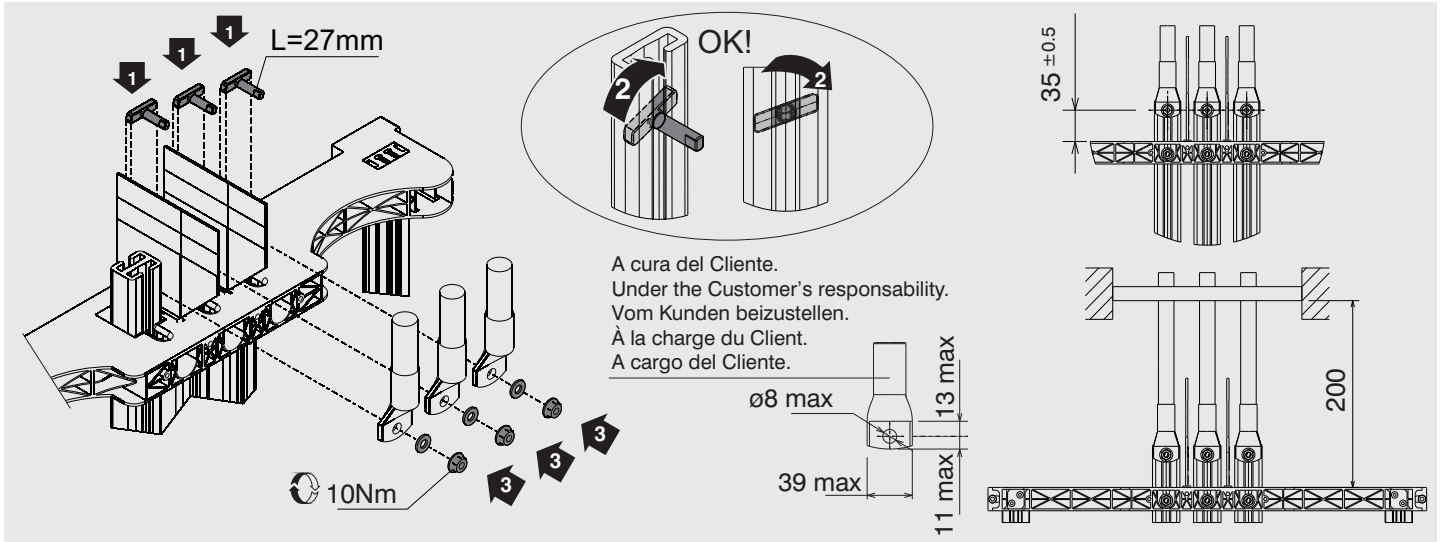

P

Example mounting outgoing for A1; for all.

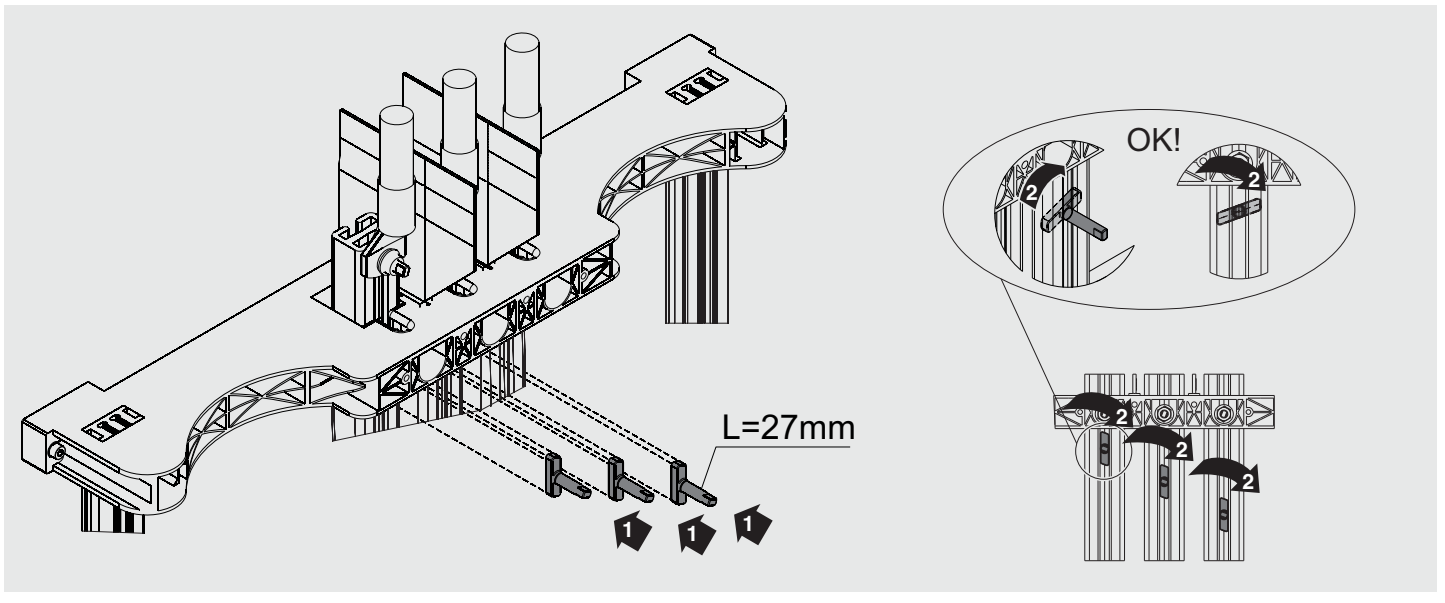

Q

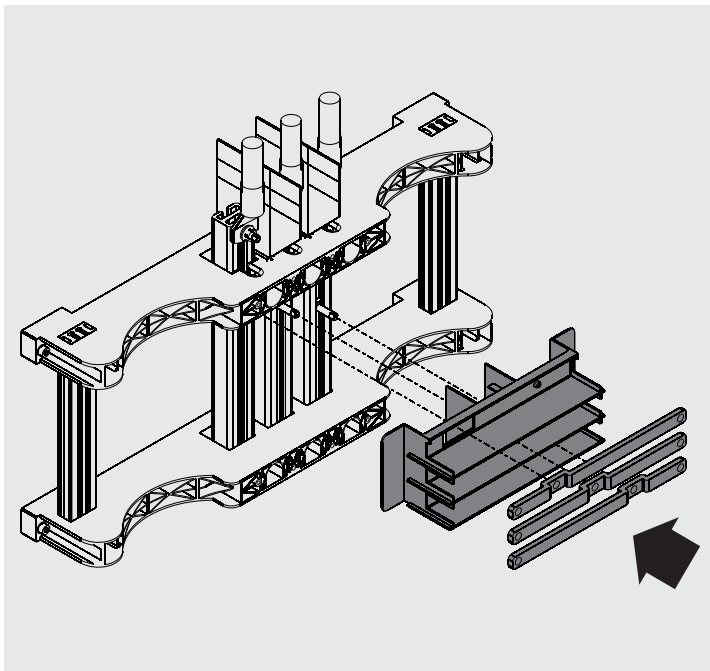

R

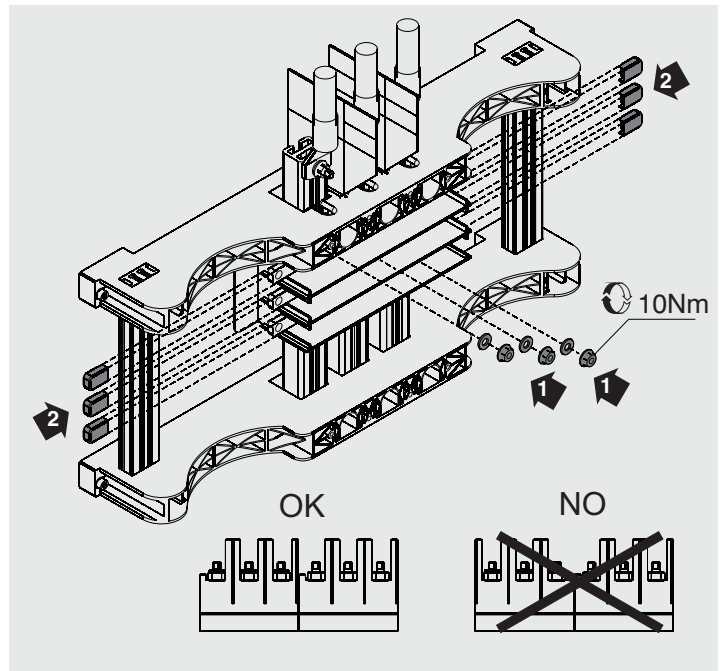

S

for A1-A2

T

for A1 only

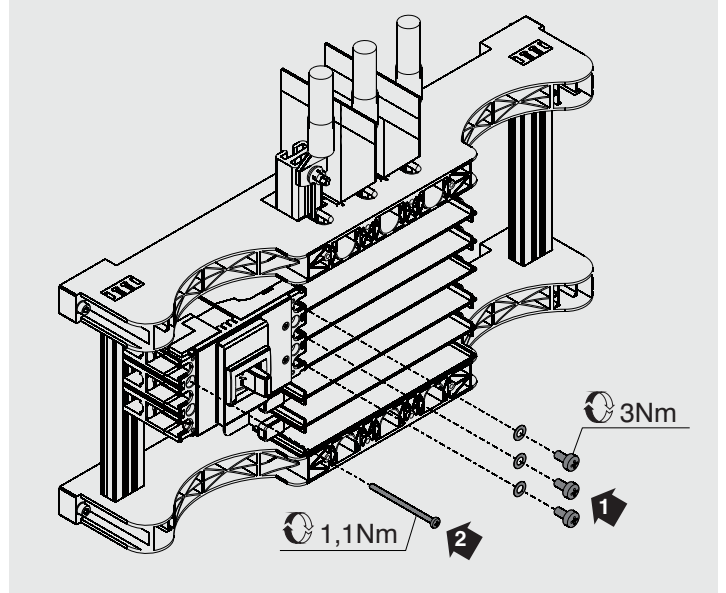
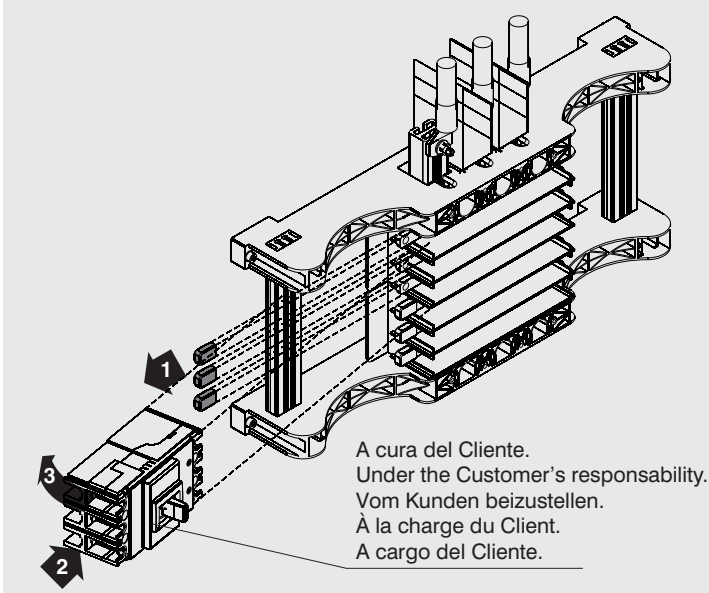
**U**

for A2 only

V

for A1-A2

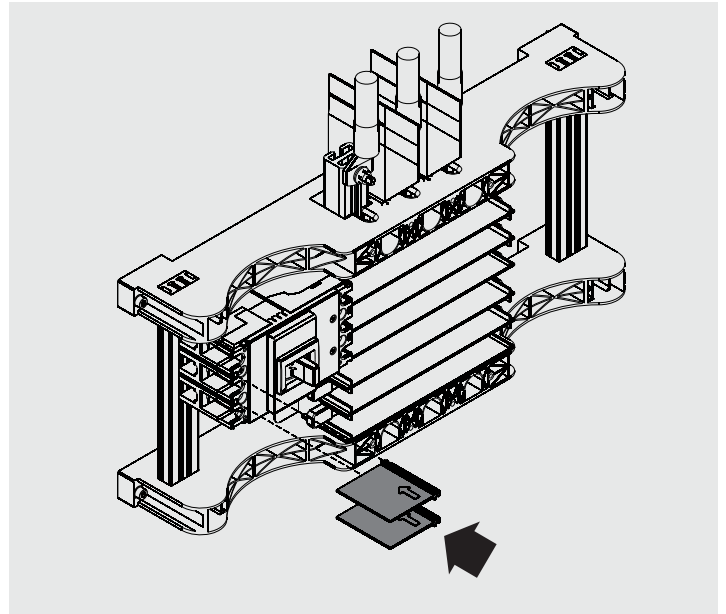
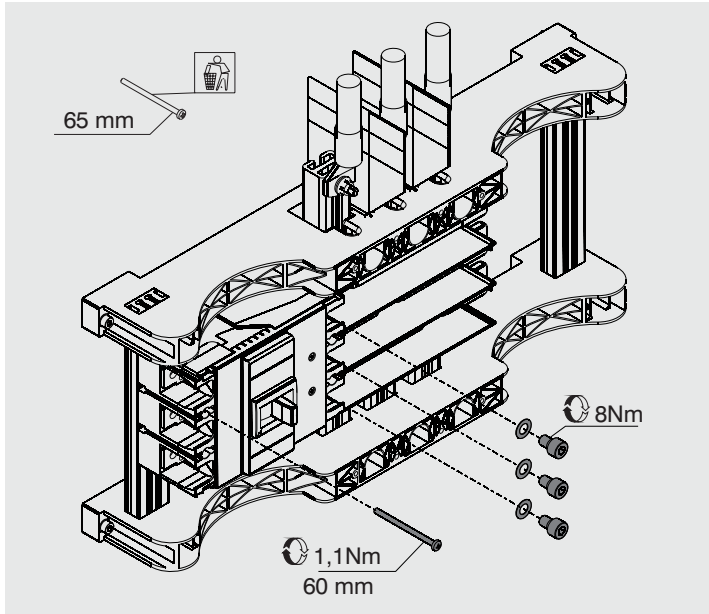
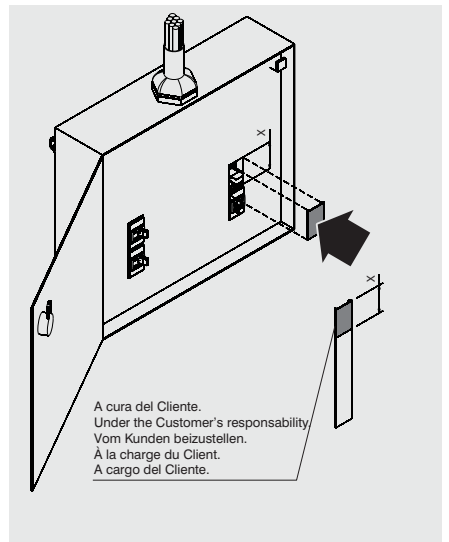
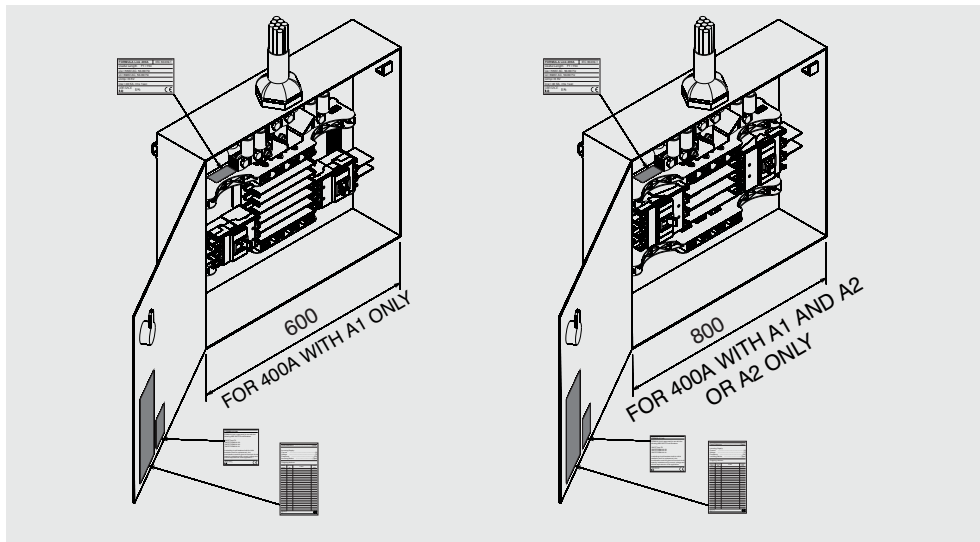
**W****X**

Y

| | 250A | A | B |
|----|-------|-------|-------|
| F1 | 4 WA1 | 154 | 179 |
| F2 | 6 WA1 | 230.5 | 255.5 |
| F3 | 8 WA1 | 307.5 | 332.5 |
| F4 | 10WA1 | 384 | 409 |
| F5 | 12WA1 | 461 | 486 |

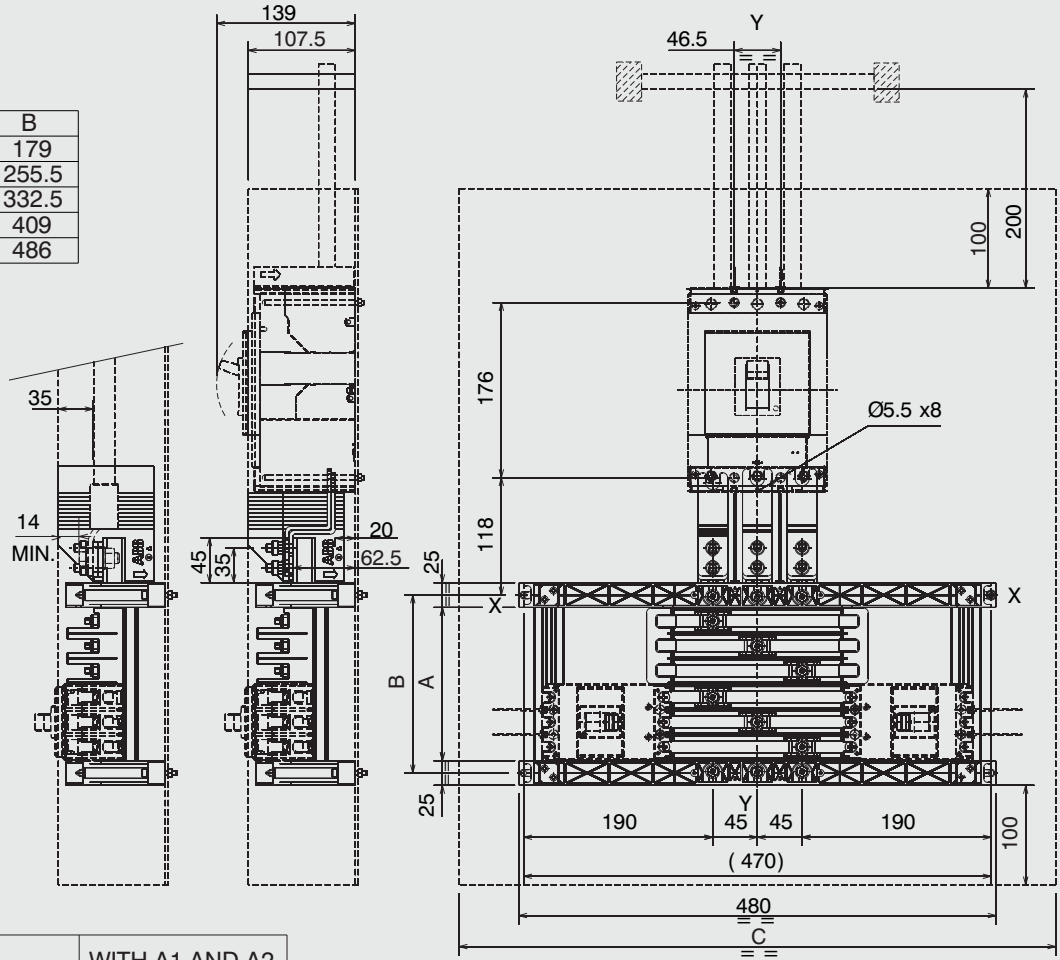

| | WITH A1 ONLY | WITH A1 AND A2, OR A2 ONLY |
|---|--------------|-------------------------------|
| C | 600 | 800 |

Z

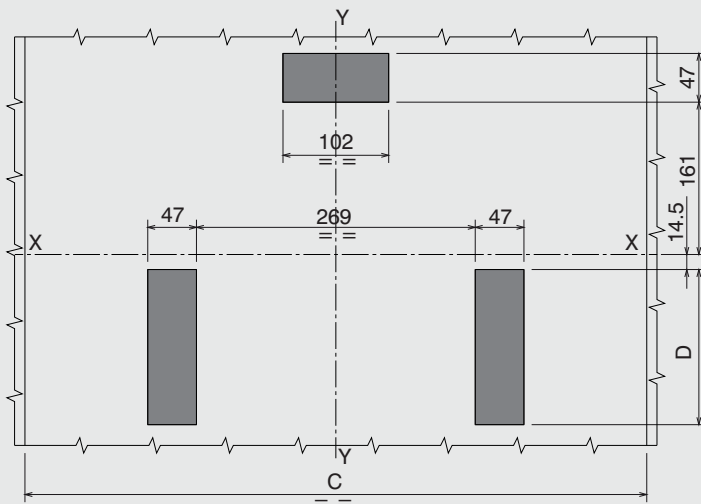

| | 250A | D |
|----|-------|-------|
| F1 | 4 WA1 | 150 |
| F2 | 6 WA1 | 226.5 |
| F3 | 8 WA1 | 303 |
| F4 | 10WA1 | 380 |
| F5 | 12WA1 | 456.5 |

| | WITH A1 ONLY | WITH A1 AND A2, OR A2 ONLY |
|---|--------------|-------------------------------|
| C | 600 | 800 |