

RELION®

Power system protection and automation reference

Enhancing power system reliability with IEC 61850



Enhancing power system reliability with IEC 61850

Fast and redundant communication network core enabler for the power system management at Helsinki-Vantaa airport

Vantaan Aviaenergia Oy is a subsidiary of Vantaan Energia Oy, a community-owned power utility of the city of Vantaa, Finland. Aviaenergia is responsible for the power distribution and district heating of the Helsinki-Vantaa international airport. The company supplies secured power to the mission critical functions of the airport, for the convenience and safety of over 12 million travellers a year. As part of the airport redevelopment initiative one of the 20 kV switching substations was moved to another location and subsequently updated. The updated switching substation was equipped with new switchgear and advanced IEC 61850 compliant Relion® 630 series protection and control IEDs (Intelligent Electronic Devices). The strategic decision to use IEC 61850 compliant IEDs laid the foundation for harmonized process interfaces, thus contributing to efficient network management.

The new 20 kV switching substation at the airport plays a crucial role in securing power distribution to the main functions of the airport including air traffic control and surveillance, apron lighting and runway lights, flight gates and terminals, and other infrastructure such as hotels and parking premises. Currently Aviaenergia supplies about 150 GWh of electricity per year to the airport. In the future the substation will also supply power to the new underground railway station for the connection to the Helsinki city centre. On the network control centre (NCC) level Aviaenergia has relied on ABB's MicroSCADA technology since the early nineties. Over the years the SCADA system has been updated and extended. New sophisticated features have been taken into use enabling efficient operation and management of the network.

The new 20 kV switching substation plays a crucial role in securing power distribution to the main functions of the airport. Source Finavia



—
Erkki Yrjölä, CEO of
Vantaan Aviaenergia Oy.



Focusing on the reliability of the power system

In the distribution network of Aviaenergia reliability is a major issue. According to the aviation regulations two alternative power supplies must continuously be available under low visibility conditions. This has been carried out with two main power transformers, which are fed from two different parts of the national grid. In the distribution network the separateness has been implemented by interconnecting the transforming stations to chains. These chains connecting the power infeed points are fed from both ends. The chains are normally open in the middle. In a fault situation the cold transforming stations along the intermediate connection are switched for supply from the healthy network. The supply of the most important transforming station chains is restored manually directly in the substations, the rest of the transforming station chains have been gathered for supply from the main switching stations. When one of the main transformer feeders is out of operation the supply of spare power is secured with reserve power generating sets. "The operational reliability of our power system is occasionally challenged. In 2003, for instance, when the entire capital region suffered

from a power outage, only one of the substations of Aviaenergia got cold. Power was supplied from the 110 kV network to the second switching substation and the airport functions were maintained on normal level," reveals Mr **Erkki Yrjölä**, CEO of Vantaan Aviaenergia Oy. On the user interface of the MicroSCADA system of Aviaenergia the whole distribution system is displayed in one application view. The current switching state of the distribution network is thus easily and instantly displayed.

Fast communication for secured power distribution

The development of the power distribution system of Aviaenergia is focused on operational reliability. In line with this Aviaenergia renewed its local data communication network in 2007. "The power system network management depends on reliable communication channels. The reliability and disturbance occurrence of the power distribution system is supervised over the communication network," Erkki Yrjölä tells. Some of the copper wiring and serial communication solutions have been replaced by a uniform fibre cable ring with some 30 switches installed to secure an undisturbed transfer of information even when a link is broken somewhere in the network. In this way single point of failure concerns can be avoided and the reliability of the communication can be improved. Using VLAN technology the fibre network can also carry camera surveillance information and VOIP phone services in the area. "We have also made provisions for an increasing transfer of information in our network. We raised the speed of the network from 10 kbps to 1 Gbps," Erkki Yrjölä specifies. The automation system of the distribution network benefits from the direct IEC 61850 communication link from the REF630 IEDs of the switchgear system to the MicroSCADA network control and management system. "It was a technically reliable and a cost-effective solution to directly link the protection relays to the MicroSCADA system. The fast communication network with its direct link provides a solid platform for the management and operational reliability of our network," Erkki Yrjölä rounds up.

Renewal of the 20kV switching substation

As part of the rearrangements at the airport the one of the two 20 kV switching substations had to be moved and rebuilt from the ground up. The old substation included Strömberg's (now ABB) switchgear systems delivered in the 70's and Strömberg's J-series static protection relays. The renewal of the first substation, which included third party IEC 61850 compliant relays, required a solution in the second substation, which would support the use of the new IEC 61850 standard. As part of the renewal of the second substation ABB's Unigear switchgear was installed including Relion® REF630 Feeder Protection and Control IEDs. By renewing the old relays major improvements were achieved within the field of protection, measurement and supervision of the substation. The power distribution network at the airport utilizes the Ethernet based IEC 61850 communication protocol for both substations. The commitment to the IEC 61850 standard enabled a harmonization

of both substations including similar functional and operational principles. This points at an essential advantage of the standard; the interoperability between devices of different manufacturers. "We made a strategic decision to switch to a technology based on the new IEC 61850 standard. My conviction that this was a correct decision has strengthened," Erkki Yrjölä admits.

For the substation horizontal communication GOOSE (Generic Object Oriented Substation Event) messaging is used. GOOSE messaging has enabled supervised transfer of status information of earthing switches. Hardwired solutions include a bunch of good technology but supervision of the communication is much harder to achieve than in IEC 61850 based GOOSE solutions. Using GOOSE the communication supervision is a natural and integral part of the communication, which makes system enhancements easier to administrate.

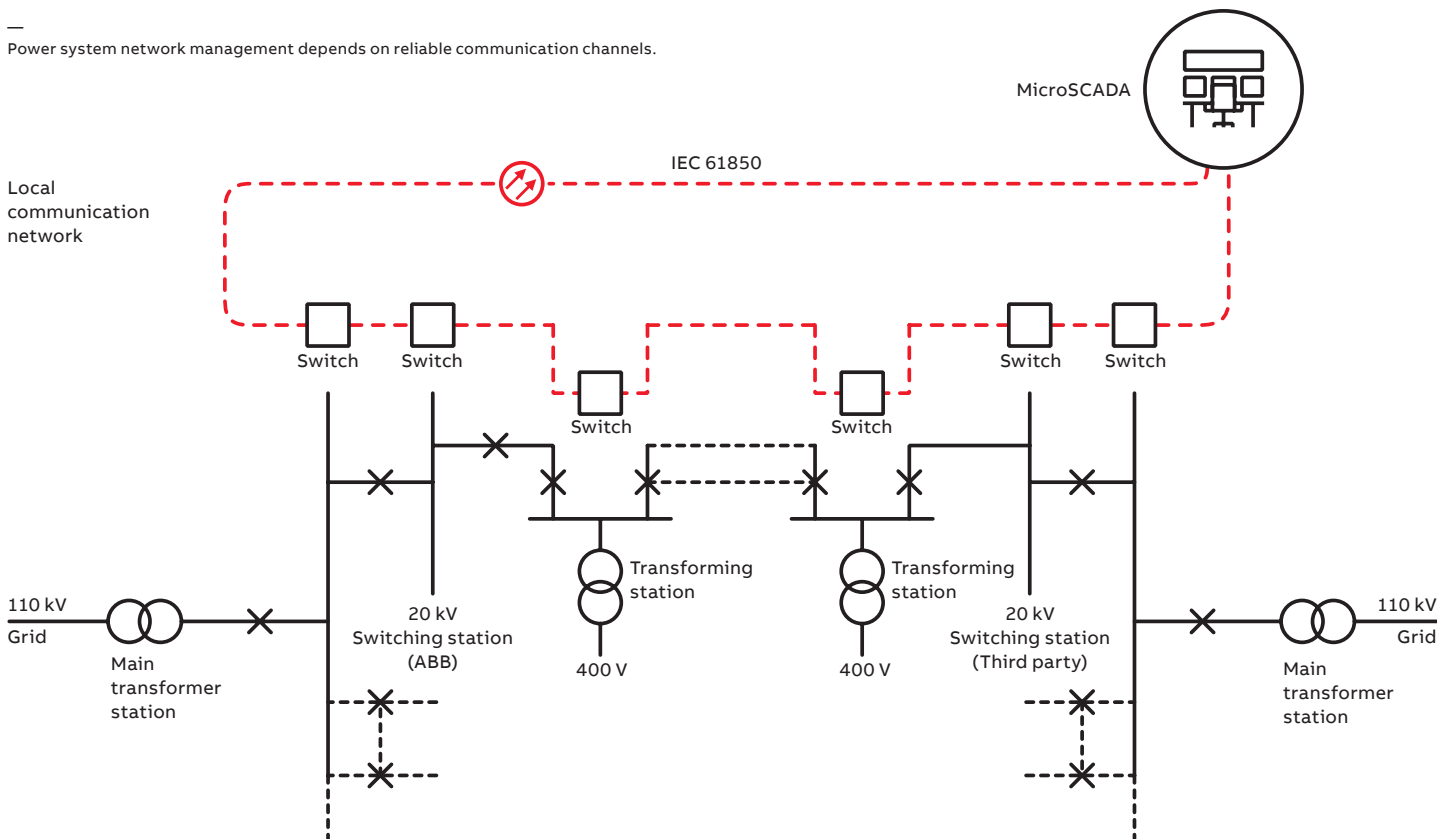



—
The 630 series IEDs and REA arc protection system were installed in ABB's Unigear switchgear.

Arc protection contributes to increased personnel safety

At Helsinki-Vantaa airport regular inspections of the substations are conducted as one measure to minimize disturbance in the power supply of the airport's critical functions and to keep up the knowledge base of the service technicians so that they can execute correct actions in disturbance situations. As personnel safety plays a crucial role at Aviaenergia the utility decided to enhance protection at the substation by installing ABB's REA 101 arc fault protection system including two REA 107 extension units. Lens type arc detection sensors are used throughout the substation. The capacity of the REA 107 extension units enables three sensors to be installed in each cubicle of the switchgear.

Arcs faults in the switchgear are usually hard to predict as they, in most cases, are caused by human errors in connection with, for instance, maintenance work. However, by including an arc protection system in the switchgear both the risk of losing human lives and suffering material damage is reduced. Furthermore, by reducing material damage of the switchgear in an arc fault the power system downtimes can be reduced. In addition, due to the

location of the substation at the Helsinki-Vantaa airport the personnel and passenger safety must be taken into consideration and the possible material damage and disturbance of the daily operations must be reduced to a minimum, thus contributing to the airport safety program. "We have standardized our protection system solutions. Arc fault protection is part of this standard solution," says Erkki Yrjölä.

Targeting zero faults by condition management

Aviaenergia is one of the Finnish forerunners in the implementation of a reliability centred maintenance (RCM) strategy for the power system. The aim of the pre-emptive maintenance program of Aviaenergia is to avoid distribution interruptions and maintain a continuous power supply to the airport by well-timed execution of preventive maintenance and life-cycle management related investments. "If you aim at zero faults your condition management program must be composed of preventive maintenance, life-cycle investments and risk investigation," Erkki Yrjölä explains. Condition-based maintenance measures support the operational reliability of the power system, maintain its distribution capability and support asset management. The operational reliability is composed of the primary and secondary circuits and of information about the operational condition of the equipment concerned. The primary and secondary equipment of Aviaenergia is under continuous supervision. Information about the states of, for instance, the loading conditions of power transformers and the station batteries are transferred over the data network to the MicroSCADA control and management system. From this information the system generates trend reports to support decision-making in the maintenance program. Moreover, all abnormal events in the power system and the equipment and all corrective measures are systematically recorded and analysed. "The reliable communication network we have created and the new IEC 61850 compliant protection relays enable us to develop even more intelligent condition management solutions to deliver added value to our business, now and for years ahead," Erkki Yrjölä considers.



—
For more information, please contact

ABB Distribution Solutions

P.O. Box 699

FI-65101 VAASA, Finland

Phone: +358 10 22 11

abb.com/mediumvoltage

abb.com/substationautomation