

MEDIUM VOLTAGE PRODUCTS

KECA x00 CL83 current transformer

Instructions for installation, use and maintenance



Scope of Contents

3	1. Operating conditions
3	2. Technical details
4	3. Instructions for installation
4	Safety instruction
4	Installation conditions
4	Installation on cable connectors
4	Installation on cable Clamping system
4	Secondary connections
5	Grounding wire
5	4. Instructions for use
5	Routine test report
5	5. Instructions for maintenance
5	6. Transport and storage
5	7. Recommended procedure for disposal of the LPCT
6	Dimensional drawing

Instructions for installation, use and maintenance for the KECA x00 CL83 low-power current transformers

These instructions for installation, use and maintenance are valid for KECA x00 CL83 low-power current transformers according to IEC 61869- 10 standard operating in indoor conditions.

01 Example of a label (IEC 61869-10)

02 Example of data stored in 2D Bar Code according to label parameters in picture

1. Operating conditions

The LPCT (low-power current transformer) should be mounted in dry, indoor conditions without excess ingress of dust and corrosive gases. The product must be protected against unusually heavy deposits of dust or similar pollution, as well as against direct sunshine. It is designed for standard ambient temperature between -25°C and +80°C (storage and transportation temperature between -40°C and +80°C). The altitude for mounting should be lower than 1000 m above sea level. The sensor may also be used at higher altitudes when agreed upon with the manufacturer.

The LPCT type KECA x00 CL83 is intended for use in current measurement in medium voltage switchgear. The LPCT shall be installed over a screened bushing insulator, screened insulated cable or any other type of screened insulated conductor. The case of LPCT is made from insulating plastic material. The primary conductor shall be insulated in medium and low voltage applications and screened from the application voltage in medium voltage applications – conductive screening shall be at ground potential. The insulation of primary conductor determines the highest permissible system voltage.

2. Technical details

For the LPCT dimensions see dimension drawings at the end of these instructions. Rated values for each individual LPCT are mentioned on the rating plate glued to the body. Values mentioned on the rating plate must not be exceeded.

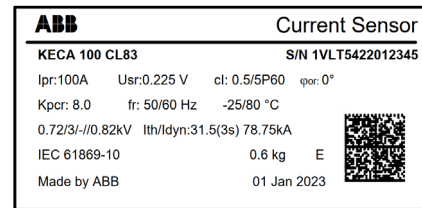

01

KECA x00 CL83	Type code
S/N	Serial number
Ipr	Rated primary current
Usr	Rated secondary output
cl.	Accuracy class
Kpcr	Rated extended primary current factor
fr	Rated frequency in Hz
Ith/Idyn	Rated short-time thermal current in kA / Rated dynamic current in kA
-25/80 °C	Ambient temperature
0,6 kg	Weight
E	Insulation class
IEC 61869-10	IEC – standard referred to
01 Jan 2023	Date of production

Tab. 1. Labels abbreviation definitions according to IEC 61869-10

POSITION	1	2	3	4	5	6	7	8	9	10	11	12	13	14	15	16	17	18	19	
DATA	K	E	C	A		1	0	0		C	L	8	3				S	/	N	
POSITION	20	21	22	23	24	25	26	27	28	29	30	31	32	33	34	35	36	37	38	
DATA			1	V	L	T	5	4	2	2	0	1	2	3	4	5		0	1	
POSITION	39	40	41	42	43	44	45	46	47	48	49	50	51	52	53	54	55	56	57	
DATA	F	E	B			2	0	2	3		U	s	r		0	.	2	2	5	0
POSITION	58	59	60	61	62	63	64	65	66	67	68	69	70	71	72	73	74	75		
DATA	V			c	l	.		0	.	5	/	5	P	6	0					

02

—
03 KECA x00 CL83
installation

—
04 Grounding of a
shielded cable

—
05 Clamping system
installation

3. Instructions for installation

Safety instruction

Always ground the LPCT grounding wire.

Installation conditions

The LPCT should be installed in dry, indoor conditions. The temperature during the assembly must be between 0°C and +40°C. The LPCT cable should not be moved or bent if the temperature is below 0°C.

Installation on cable connectors

KECA x00 CL83 is only put on the cable connector without clamping system in use. The final positioning is necessary to perform after final connector installation to the bushing. Place the body in the center of the measuring area and use a clamping system for the LPCT position fixation. Cable output must be at the top or at the bottom even in reverse position. Polarity of signal has to be considered and practically reversed in IED. KECA x00 CL83 can be additionally slightly centered to achieve optimal function after fixation, see Figure 3.



—
03

The LPCT can be used on various cable connectors with outer diameters in the range up to 83 mm (measured after cable connector installation on the bushing). All types of connectors which are used with LPCT must be shielded.

Installation on cable

The LPCT can be used also for cable installation. In this case the end of the shield near the device is grounded by a wire that passes through the sensor window, as shown in Figure 4. The wire must be kept outside the clamping systems. The current flowing in the shield flows through the grounding lead, which is also in the LPCT window. The fluxes produced by the current flow in the shield and in the grounding lead are equal but opposite in direction and, therefore, the output of the LPCT is not affected by the flow of current in the shield.

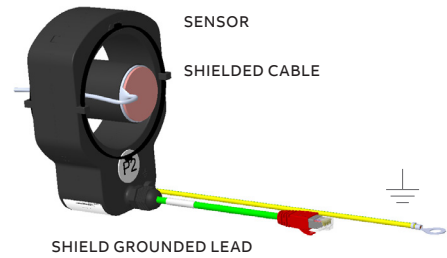

—
04

Clamping system

It is necessary to install tightening strip in the correct position according to Figure 5 where the place for the strip connection must be observed.



—
05

Secondary connections

The secondary cable is a single shielded cable designed to give maximum shielding. The LPCT is equipped with a cable for connection with the IED. The cable termination can be realized with cable connector RJ45 (standard solution) or with ferrules.

The secondary cable is inseparable part of each LPCT and cannot be additionally extended, shortened, branched, modified, withdrawn or changed due to the guarantee of accuracy and performance of the sensor.

The cable must be connected directly (or via a connector adapter if needed - for more information about connector adapters and coupling adapter refer to Doc. No. 1VLC000710 - Sensor Accessories) to electronic measurement equipment (e.g. IED). The electrical shielding of cable is connected to connector shielding and must be earthed on "electronic measurement equipment" side. The cable must be fixed close to metal wall or inserted inside of metal cable tray far from power cables! The minimal bending radius for the cable is 35 mm. The cable is not to be moved if the temperature is below 0°C. If cable, connector or connector grommet is damaged please contact the manufacturer for instructions.

The used RJ45-type connectors are screened and designed to guarantee low resistance shielding; they are particularly adapted to applications

—
06 RJ45 connector (IEC 61869-10)

—
07 Ferrules

—
08 KECA x00 CL83 sensor plug connector pin's assignment (IEC 61869-10)

—
09 Detail of the LPCT's grounding wire

where electromagnetic compatibility (EMC) is important. The connectors are robust but it is necessary to be careful during their assembly – do not use force!

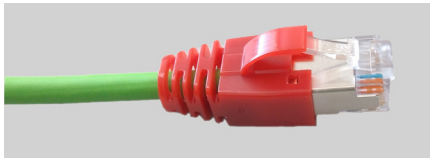

—
06

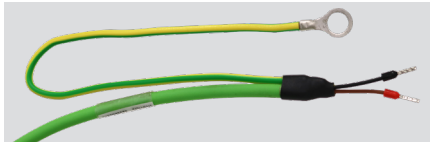

—
07

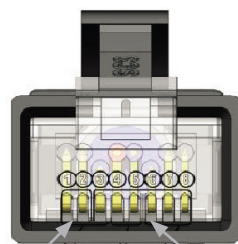

current (1-2) not used (3-8)

—
08

Sensor wires connected acc. following assignment:

PIN 4 - S1

PIN 5 - S2

Other pins remain unused

A cable not connected to the relay can be left open or short-circuited without any harm for the LPCT. Even during a primary short-circuit the voltage in the secondary circuit of the current sensor will be below 100 V. Nevertheless it is a good safety practice to earth cables not connected to the relay. RJ45 plug connector has 8 contacts and locking latch coupling. The sensor connector plug must be inserted properly with the relay mating receptacle before completing the coupling with the bayonet lock. Take care and do not use excessive force to plug-in and plug-out.

Grounding wire

The LPCT's grounding wire is located on the one side of sensor and must be connected to the ground during the device operation. For proper grounding yellow-green cable (length 0.25 m) terminated with cable eye M8 is used.

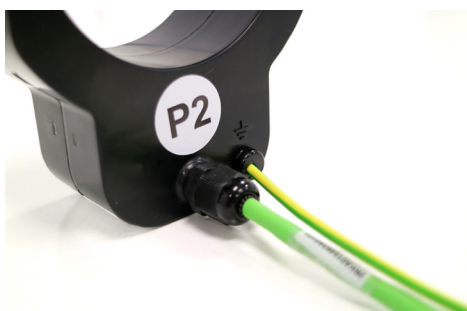

—
09

4. Instructions for use

The LPCTs are used:

- To convert large currents in the primary circuit of the network to the appropriate signal for the secondary equipment (e.g. IEDs)
- To insulate primary and secondary circuits from each other
- To protect secondary equipment from harmful effects or large currents during abnormal situations in the network

The use of a LPCT for other purposes than those described above is forbidden.

Routine test report

The routine test report includes following tests:

- Verification of terminal marking
- Power-frequency withstand test on secondary terminals / Power-frequency voltage withstand test for low-voltage components
- Test for accuracy

5. Instructions for maintenance

Excessive dust or other kinds of pollution must be brushed off the LPCT. Polluted devices can be cleaned with alcohol, petrol or toluene. Otherwise, during normal use the LPCTs do not need any additional maintenance.

6. Transport and storage

The permissible transport and storage temperature for LPCT is from -40 to +80°C. During transport and storage the LPCTs must be protected against direct sunshine. The LPCTs are delivered packed into wooden boxes or transport pallets.

7. Recommended procedure for disposal of the sensor

The product does not contain environmentally hazardous materials. For disposal of the product after it has been taken out of use, local regulations, if there are any, should be followed.

Dimensional drawing KECA x00 CL83

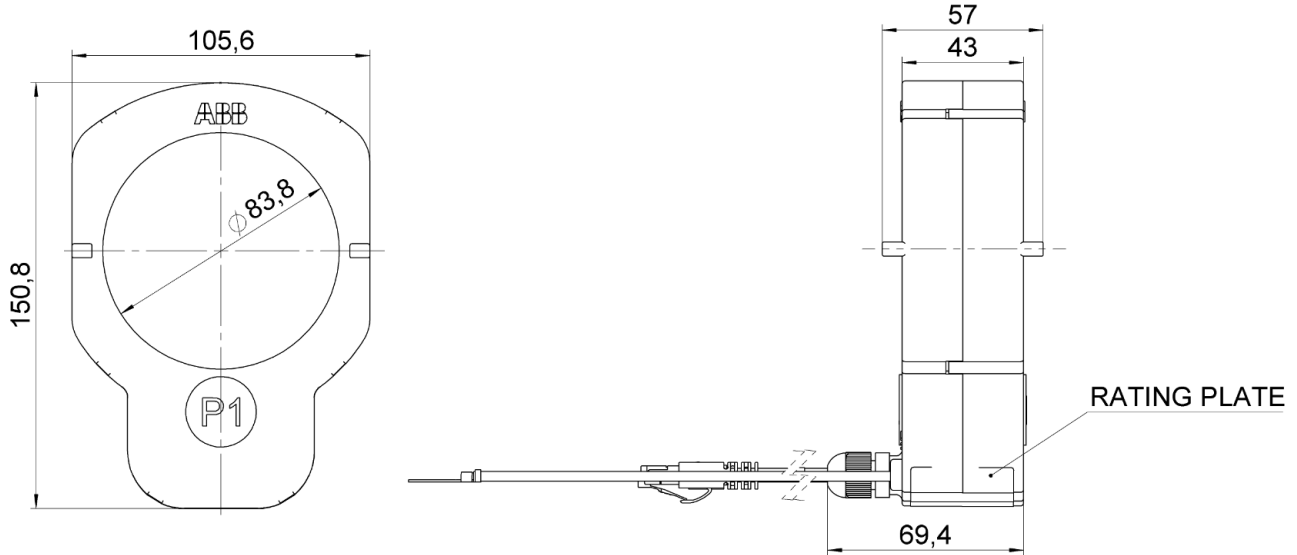

GROUND WIRE LENGHT IS 0,25m, EYE M8

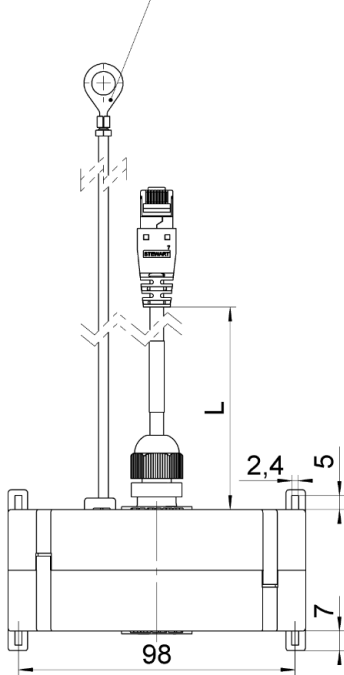

S2 BLACK FERRULE - BLACK WIRE

S1 RED FERRULE - BROWN WIRE

GROUND WIRE LENGHT IS 0,25m, EYE M8

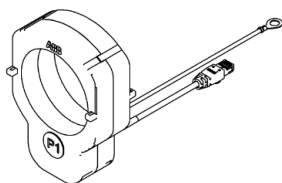
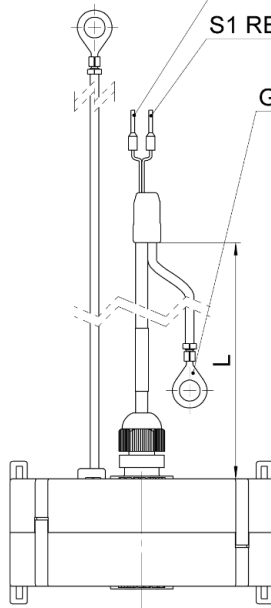

CONNECTOR RJ45 CAT6
IEC 61869-10

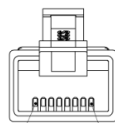

PIN1 PIN8

PIN1 - COIL START (S1)
PIN2 - COIL END (S2)

CONTACT US

ABB s.r.o.
ELDS Brno
Videnska 117, 619 00 Brno,
Czech Republic
Tel.: +420 547 152 021
+420 547 152 854
Fax: +420 547 152 626
E-mail: kontakt@cz.abb.com

NOTE

We reserve the right to make technical changes or modify the contents of this document without prior notice. With regard to purchase orders, the agreed particulars shall prevail. ABB does not accept any responsibility whatsoever for potential errors or possible lack of information in this document.

We reserve all rights in this document and in the subject matter and illustrations contained therein. Any reproduction, disclosure to third parties or utilization of its contents - in whole or in parts - is forbidden without prior written consent of ABB.

Copyright© 2023 ABB
All rights reserved