

ABB MEASUREMENT & ANALYTICS

LiMCA III

Liquid metal cleanliness analyzer



Measurement made easy

The LiMCA III is a versatile aluminium cleanliness analyzer that can be used to sample at multiple locations along the casting lines of most casthouses.

LiMCA III measurement overview

The LiMCA III uses the proven LiMCA measurement principle that is the industry standard for measuring non-metallic inclusions in molten aluminium.

It can be used under harsh industrial production conditions to provide an accurate indicator for the metal cleanliness of aluminium alloys. The LiMCA III takes advantage of a lighter measuring head for more versatile and flexible positioning in molten metal than previous LiMCA analyzers. Its lower center of gravity makes it also more stable and easy to maneuver. Furthermore, the LiMCA III comes with a laser level sensor that enables automatic raising and lowering of the measurement head to adapt to the varying levels of molten metal during a cast.

The LiMCA III system measures total concentration and size distribution of inclusions found in aluminium alloys. Its measuring principle is based on an objective and user-independent method. It is ideally suited for process control and quality assurance. The LiMCA III system can characterize the cleanliness of a melt at time intervals in the order of one minute. It can therefore monitor, in real-time, the evolution of cleanliness along a cast as a function of process parameters and melt-handling practices. The impact of furnace preparation, alloying practice, feedstock mix, settling time, and similar parameters on melt cleanliness is easily determined.

To maintain their competitive edge, world-class aluminium plants must precisely monitor the quality of their aluminium production in real time. They need to find crucial information at a glance and easily access their process data. The LiMCA III can meet all these challenges.

Features

- Online real-time inclusion measurement
- Concentration and size of inclusions
- Measurement at any point along the process
- AC modulation to eliminate the use of batteries
- Readings unaffected by the electromagnetic noise of casting environments
- Standard web-based HMI runs on most computers and tablets
- Self-contained analyzer (dedicated server not required)



Effects of settling on cleanliness

Settling time is often based on experience. What if you knew the level of cleanliness you could achieve just by selecting the right settling time in your furnace? Without this information, productivity is lost.

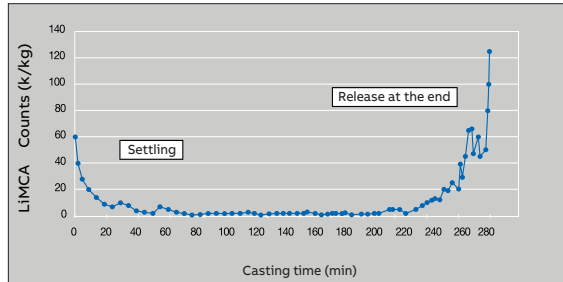

Inclusion release from a sudden metal level change while casting

When systems are unstable, variations in quality occur. What if you knew how and why your process was unstable? Without this information, it is difficult to know the cause of your rejects.

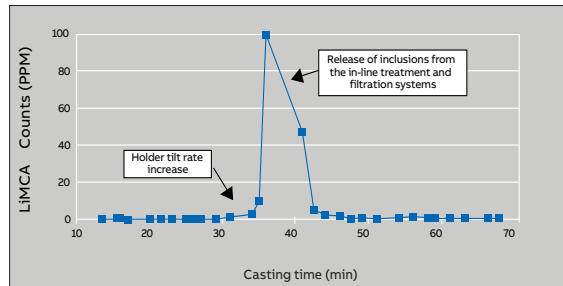

LiMCA results showing filter efficiency

Top quality producing plants rely on expensive in-line filtration systems. What if you knew your filtration efficiency and its limitations? Without this information, you may use your filtration system incorrectly.

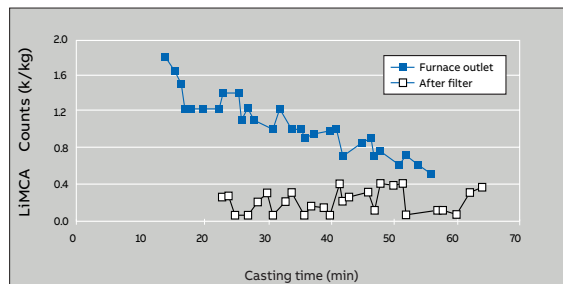

The technique used is based on the resistive pulse/electric sensing zone (ESZ) technique. LiMCA III systems measure the total concentration and granulometry of dielectric inclusions in suspension in molten aluminium and aluminium alloys. The workings of a basic LiMCA instrument are illustrated in the following figure. The instrument supports a closed tube, with a small orifice, that is positioned

in liquid metal. A vacuum created inside the tube forces the liquid metal and its suspended particles to flow through the small orifice, filling the tube. This tube is made of electrically insulating material. There are two types of electrodes: one in-probe electrode located inside the tube, and four external electrodes. All electrodes are immersed in the liquid metal. An alternative electrical current is applied between the in-probe and the external electrodes, and flows through the liquid metal in the small orifice of the tube. The presence of a particle in the liquid flow, when going through the orifice, modifies the electrical resistance detected at the orifice.

When a particle enters the orifice, it displaces its volume of the conducting fluid, causing a temporary rise in the electrical resistance of the orifice. This resistance change, in the presence of the applied current, causes a voltage pulse of duration approximately equal to the transit time of the particle to appear across the orifice. The electrical potential produced by the constant current varies in relation to the change in resistance each time a particle goes through the orifice. A detection circuit determines the size of the particle from the change in voltage caused by its presence. The magnitude of the change depends on the volume of the particle. A difference in voltage due to the passage of a particle takes the form of a pulse on the reference line. The reference line corresponds to the voltage created by the constant current going through the circuit consisting of the electrodes and the liquid metal when no inclusions are present.

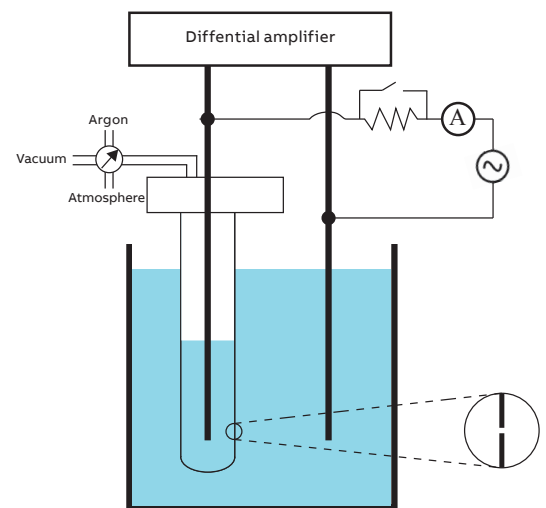

Web-based software

The LiMCA III is operated via a web-based software. There is no need to install any software in customer control systems or computers. The software is built in the LiMCA III and can be accessed via a web browser. The LiMCA III internet interface is the

primary graphical user interface (GUI) tool to control, monitor and configure the LiMCA III analyzer. The application also provides a complete set of tools to view and manage the inclusion, status and log data produced by the LiMCA III system.

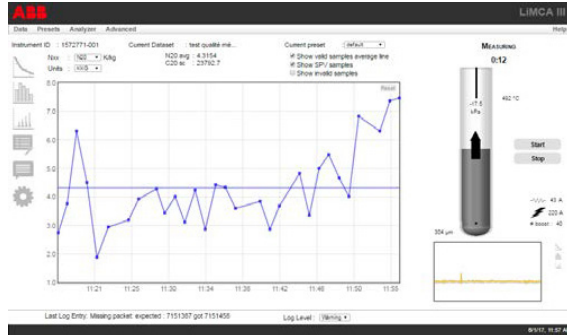

Data from time display-screen

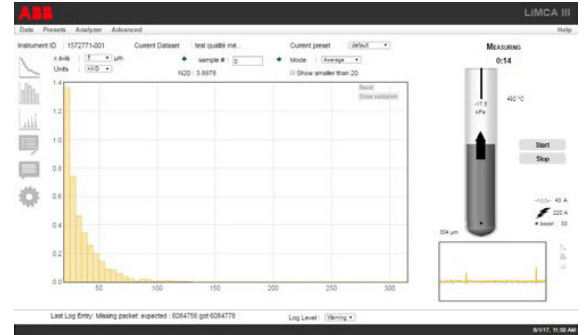

Data from histogram screen

LiMCA III complementary offering

Category	Part number	Description
Accessories	AA009657-01	LiMCA III transit case
	0050-13-0-00003-01	LiMCA III mobile filtration assembly
	0050-13-0-00005-01	LiMCA III tool kit
	AA027921-01	LiMCA III heat insulation blanket
	0050-13-0-00010-01	LiMCA III 3rd wheel kit
	AA011856-01	LiMCA III mandrel heat deflector
Consumables	0050-19-0-00003-01	LiMCA III In-probe electrode set (lot of 4)
	0050-19-0-00003-02	LiMCA III extended In-probe electrode set (lot of 4)
	0050-19-0-00002-01	LiMCA III external electrodes set (lot of 4)
	0050-19-0-00004-01	LiMCA III in-probe melt level detectors set (lot of 5)
	0050-19-0-00004-02	LiMCA III extended In-probe melt level detectors set (lot of 5)
	0004-19-0-00003-01	LiMCA III maximum Immersion detectors set (lot of 2)
	0050-19-0-00005-01	LiMCA III in-probe safety level assembly (lot of 2)
Maintenance kit	0050-13-0-00002-01	LiMCA III mobile filtration maintenance kit
	0050-13-0-00006-01	LiMCA III spare part kit

01 LiMCA III extended in-probe electrode set

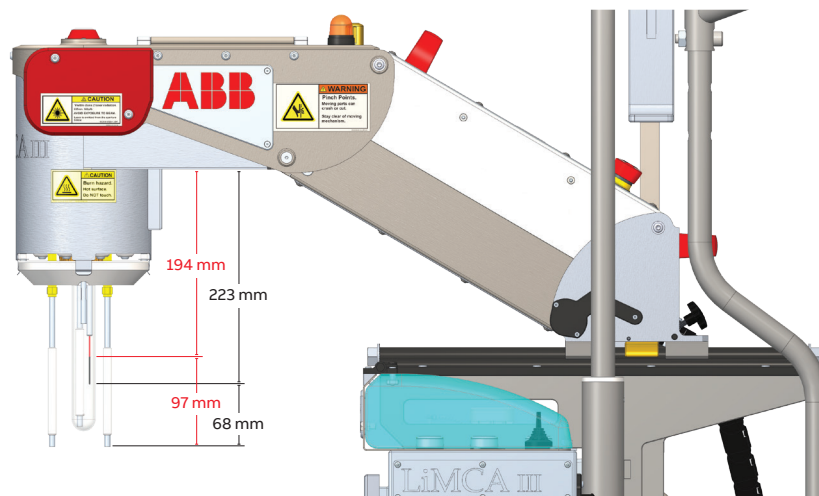

Versatile and flexible positioning of measuring head

Three positioning systems combined to offer a wide range of motion.



1. Upward/downward mechanical actuator positioning system

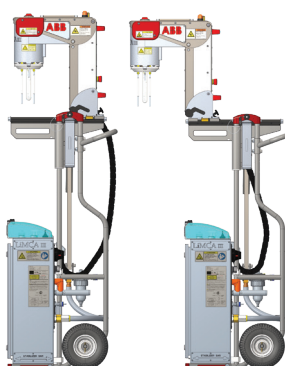

2. Forward/aft manual positioning rail system

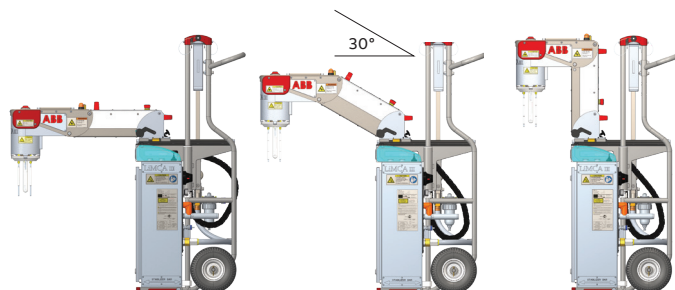

3. Automated/manual electrical actuator with tracking system. 30°C is the optimal working position to automatically adjust the probe to aluminum level changes.

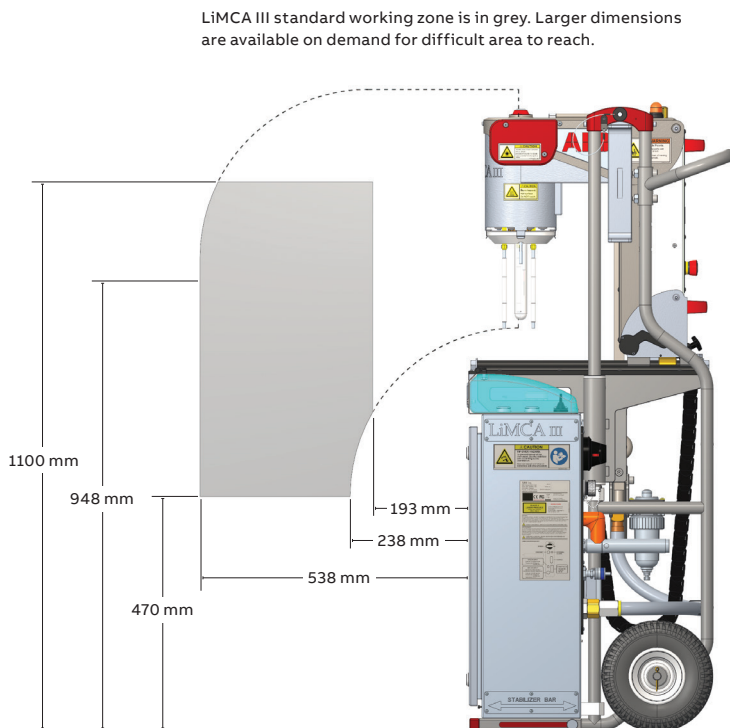
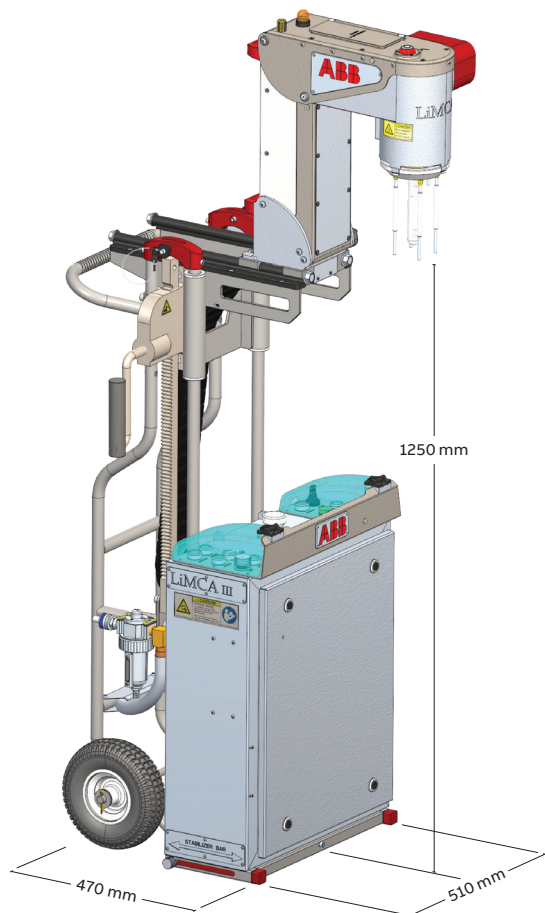

LIMCA III standard working zone is in grey. Larger dimensions are available on demand for difficult area to reach.

Technical specifications

Measurements	
Particle size measurement	20 to 155 µm
Particle size detection	15 to 300 µm
Inclusion concentration (numerical)	0.05 to 1000 k/kg
Reproducibility at high inclusion concentration	±10%
Reproducibility at low inclusion concentration	Dominated by statistical noise
Typical melt sample mass	17.5 g
Typical melt sample volume	7.5 ml
Typical data sample interval	80.0 seconds
Ambient specifications	
Operating ambient temperature	0 to 50 °C (32 to 122 °F), with active cooling
Storage ambient temperature	-20 to +40 °C (-4 to 104 °F)
Internal operating temperature	-5 to +50 °C (23 to 122 °F)
Ambient humidity	35 to 85% RH, non-condensing
Electric power supply specifications	
Rated nominal line voltage	100 to 240 VAC, autoselect
Line voltage phases	Single, neutral grounded VAC
Maximum line voltage fluctuation	10%
Rated frequency	47 to 63 Hz
Rated power consumption	200 VA average, 450 VA peak
Breaker type (100 to 240 VAC)	5A, 2 poles, Tripping curve K (according to IEC/EN 60947-2)
Minimum extension wire gauge	18 AWG
Analyzer compressed air supply specifications	
Maximum temperature	40 °C (104 °F)
Minimum pressure	552 kPa (80 psi)
Maximum input pressure	1400 kPa (200 psi)
Flow at 552 kPa (80 psig)	481 SLPM, typically 17 SCFM (max. 25 SCFM)
Filter	0.3 µm
Purity	99%
Dew point	-40 °C (-40 °F)
LiMCA air hose internal diameter	19.05 mm (0.75 in)
Plant argon hose minimum internal diameter	12.7 mm (0.5 in)
Analyzer compressed argon supply specifications	
Maximum temperature	40 °C (104 °F)
Minimum pressure	414 kPa (60.02 psi)
Maximum input pressure	800 kPa (115 psi)
Minimum flow	0.015 m ³ /min, 0.5 SCFM
Filter size	40 µm
Purity	99%
Dew point	-40 °C (-40 °F)
LiMCA argon hose internal diameter	4 mm (3/16 in)
Plant argon hose minimum internal diameter	6 mm (1/4 in)
Laser specifications	
Laser classification	Class 2 (IEC) / wClass II (FDA)
Laser power	Less than 1 mW
Laser light source wavelength	655 nm
Laser light source	visible red light
Laser measuring range	200-1000 mm (7.9 - 39 in)
Laser measuring resolution	0.3 mm
Analyzer mechanical specifications	
Mass	80 kg (176 lbs)
Height	1260 mm (50 in)
Width	510 mm (20 in)
Depth	470 mm (19 in)
Transit case mass	65 kg (143 lbs)



ABB Inc.

Measurement & Analytics

3400, rue Pierre-Ardouin

Québec (Québec) G1P 0B2

Canada

Tel.: +1 418-877-2944 (worldwide)

1 800-858-3847 (North America)

Email: metal@ca.abb.com

abb.com/analytical

Additional information

We reserve the right to make technical changes or modify the contents of this document without prior notice. With regard to purchase orders, the agreed particulars shall prevail. ABB does not accept any responsibility whatsoever for potential errors or possible lack of information in this document.

We reserve all rights in this document and in the subject matter and illustrations contained therein. Any reproduction, disclosure to third parties or utilization of its contents – in whole or in parts – is forbidden without prior written consent of ABB.

© Copyright 2023 ABB. All rights reserved.
Specifications subject to change without notice.