



ABB GENERAL PURPOSE DRIVES

ACP510-01 Drive

Quick installation and start-up guide Frames R1 to R5



Ecodesign (EU 2019/1781)

About this document



3AXD50001148188
Rev A EN 2024-03-30
©2024 ABB All rights reserved.



Safety Instructions

WARNING! Obey these instructions. If you ignore them, injury or death, or damage to the equipment can occur.

- If you are not a qualified electrician, do not do electrical installation work.
- Do not work on the drive, motor cable or motor when main power is applied. If the drive is already connected to the input power, wait for 5 minutes after disconnecting the input power.
- Do not work on the control cables when power is applied to the drive or to the external control circuits.
- Use the lifting eyes of the drive when you lift the drive. Do not tilt the drive. The drive is heavy and its center of gravity is high. An overturning drive can cause physical injury.
- Make sure that debris from borings and grindings does not enter the drive when installing.
- Make sure that the floor below the drive and the wall where the drive is installed are non-flammable.

Check if capacitors need to be reformed

If the drive has been stored for a year or more, you must reform the capacitors.

You can determine the manufacturing time from the serial number, which you find on the type designation label attached to the drive. The serial number is of format MYYWWXXXX. YY and WW tell the manufacturing year and week as follows:

YY: 13, 14, 15, ... for 2013, 2014, 2015, ...
WW: 01, 02, 03, ... for week 1, week 2, week 3, ...

For information on reforming the capacitors, see *Converter module capacitor reforming instructions* (3BFE64059629 [English]), available on the Internet.

Select the power cables

Size the power cables according to local regulations to carry the nominal current given on the type designation label of your drive.

Ensure the cooling

The allowed ambient temperature ranges from -15°C to 40°C (+5 to +104 °F). No condensation or frost is allowed. For limitation on the ambient temperature below 0°C and above +40°C(+104 °F), see chapter *Technical data* of ACP510-01 hardware manual (3AXD50001148140 [EN]).

Protect the drive and input power cable

If you use gG fuse, please check the time-current curve to make sure that the operating time of the fuse is below 0.5 seconds. Follow the local regulations.

Install the drive

Warning! The drive module is heavy (4 to 26.5kg). Use a suitable lifting device. Do not lift the module manually. Make sure that the wall and the fixing devices can carry the weight.

Installing the drive vertically, frames size R1...R5

- Mark the hole locations using the mounting template included in the package. Do not leave the mounting template under the drive. **Note:** Only two screws should be used to fix the lower part of the drive instead of four.
- Drill the mounting holes.
- Insert the screws or bolts into the holes.

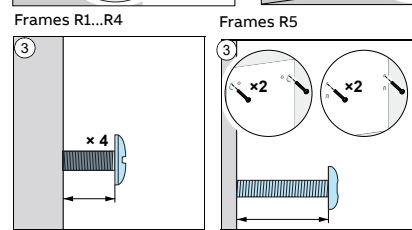
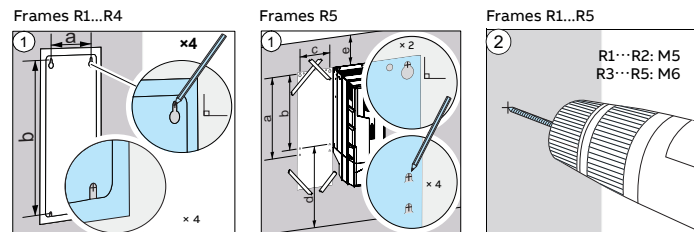

Frame size	R1	R2	R3	R4	R5
a	98	98	160	160	612
b	317	417	473	619	581
c	-	-	-	-	160
Weight	4	6	14.5	18.5	26.5

Check the insulation of the power cables and the motor

Check the insulation of the input cable according to local regulations before connecting it to the drive.

Check the insulation of the motor cable and motor before connecting it to the drive. Measure the insulation resistance between each phase conductor and the Protective Earth conductor using a measuring voltage of 1000 V DC. The insulation resistance of an ABB motor must exceed 100 Mohm (reference value at 25 °C or 77 °F). For the insulation resistance of other

motors, see the manufacturer's instructions. **Note:** Moisture inside the motor casing will reduce the insulation resistance. If moisture is suspected, dry the motor and repeat the measurement.

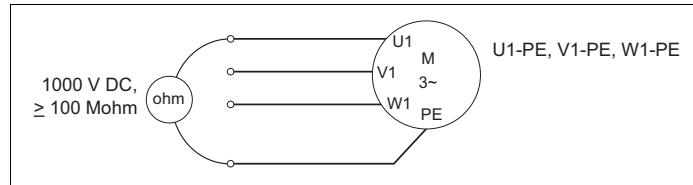

Check the compatibility with IT (ungrounded) system

WARNING! Do not install the drive with the internal EMC filter and VAR varistor connected on an IT system (an ungrounded power system or a high-resistance-grounded [over 30 ohms] power system).

If you connect the drive to an IT (ungrounded), disconnect the EMC filter and varistor before connecting the drive to the supply network. Information about how to deal with it please see chapter *Electrical installation* of ACP510-01 firmware manual (3AXD50001148140 [EN]).

Connecting the power cable

Connection diagram

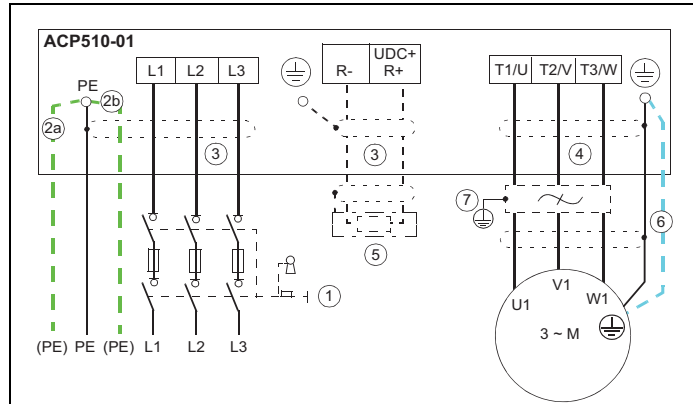

- Two protective earth (ground) conductors. Drive safety standard IEC/EN/UL 61800-5-1 requires two PE conductors, if the cross-sectional area of the PE conductor is less than 10 mm² Cu or 16 mm² Al.
- Use a separate grounding cable or a cable with a separate PE conductor for the line side, if the conductivity of the fourth conductor or shield does not meet the requirements for the PE conductor.
- Use a separate grounding cable for the motor side, if the conductivity of the shield is not sufficient, or if there is no symmetrically constructed PE conductor in the cable.
- 360-degree grounding of the cable shield is required for the motor cable and brake resistor cable (if used). It is also recommended for the input power cable.

Note:
If there is a symmetrically constructed grounding conductor on the motor cable in addition to the conductive shield, connect the grounding conductor to the grounding terminal at the drive and motor ends.
Do not use an asymmetrically constructed motor cable for motors above 30 kW. Earthing at the motor increases bearing current and power consumption, damages the motor bearing and even the motor.

Motor cables

Prepare the ends of the cable as illustrated in the figure. Two different motor cable types are shown in the figures (a,b).

Note: The bare shield will be grounded 360 degrees.

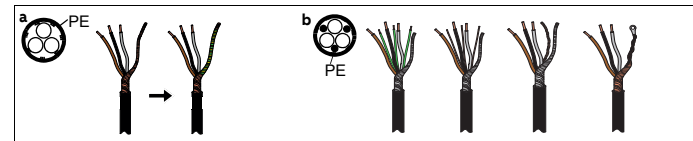

Connection procedure

- (When selecting the ABB terminal box)
1. Attach the residual voltage warning sticker in the local language next to the control board.
- Remove the shroud on the power cable terminals by releasing the clips with a screwdriver.
- Connect the input power cables and motor cables as illustrated in the figure. **Note:** The bare shield will be grounded 360 degrees. Mark the pigtail made from the shield as a PE conductor with yellow-and-green color.
- Slide the cables through the holes of the bottom plate, the motor cable to the right and the input power cable to the left.
- Connect the motor cable:
 - Ground the shield 360 degrees under the grounding clamps.
 - Connect the twisted shield of the cable to the grounding terminal.
 - Connect the phase conductors of the cable to the T1/U, T2/V and T3/W terminals.
- Connect the input power cables with the L1, L2 and L3 terminals according to step 5.
- Install the control cables with grounding frame.
- Reinstall the cover plate of the power cable terminals.
- Secure the cables outside the unit mechanically.
- Ground the motor cable shield at the motor end. For minimum radio frequency interference, ground the motor cable shield 360 degrees at the lead-through of the motor terminal box.

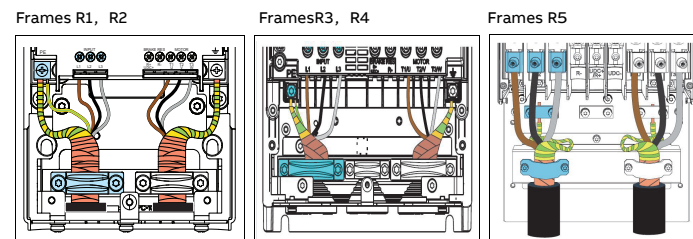

Connect the control cables

See the right figure. It is the example of one analog signal and one digital signal cable. Do the connections according to the connection macro in use.

Example of analog signal cable connection:

- Slide the cables through the holes of the bottom plate
- Ground the outer shield of the cable 360 degrees under the grounding clamp. Keep the cable stripped as close to the terminals of the control board as possible. For analog signal cables, ground also the pair-cable shields and grounding wire at the SCR1 terminal. Secure the cables mechanically at the clamps below the control unit.
- Route the cable as shown in the figure.
- Connect the conductors to the appropriate terminals of the control board and tighten to 0.5...0.6 N-m.
- Tie all control cables to the provided cable tie mounts.

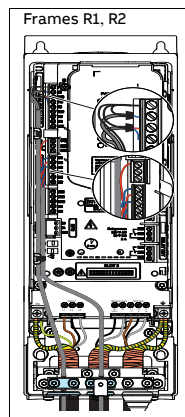

Default I/O connections (ABB standard macro)

X1	Terminal	Signal	Reference
1	SCR	Signal cable shield (screen)	
2	AI1	Output frequency reference: 0-10 V	
3	AGND	Analog input circuit, common	
4	+10V	10 V DC reference power	
5	AI2	Not configured	
6	AGND	Analog input circuit, common	
7	AO1	Output frequency: 0...20 mA	
8	AO2	Motor current: 0...20 mA	
9	AGND	Analog output circuit, common	

X2 and X3	Terminal	Signal	Reference
10	+24V	Aux-voltage output+24V DC, max. 250 mA	
11	DGND	Aux-voltage output common ground	
12	DCOM	Digital input common use	
13	DI1	Stop (0) / Start (1)	
14	DI2	Forward/Reverse selection	
15	DI3	Constant frequency selection	
16	DI4	Constant frequency selection	
17	DI5	Ramp selection: Ramp1 (0)/Ramp2	
18	DI6	Not configured	
X6 X7 X8	Terminal	Signal <td>Reference</td>	Reference
19	RO1C	Ready run	250 V AC / 30 V DC, 2 A
20	RO1A	Running	250 V AC / 30 V DC, 2 A
21	RO1B		
22	RO2C	Fault (-1)	250 V AC / 30 V DC, 2 A
23	RO2A		
24	RO2B		
25	RO3C		
26	RO3A		
27	RO3B		
X5	Terminal	Signal <td>Reference</td>	Reference
29	B+	Embedded Modbus RTU (EIA-485)	
30	A-		
31	DGND		
S100	TERM	Termination resistor switch	
S200	BIAS	Bias resistor switch	

Terminal size:

- R1...R9: 0.14...1.5 mm² (all terminals)
- Tightening torque: 0.5...0.6 N-m (0.4 lbf-ft)

Notes:

- The signal source is powered externally. See the manufacturer's instructions. To use sensors supplied by the drive auxiliary voltage output, see chapter *Electrical installation*, section *Connection examples of two-wire and three-wire sensors in the Hardware manual* of the drive.
- Ground the outer shield of the cable 360 degrees under the grounding clamp on the grounding frame for the control cables.
- Connected with jumpers at the factory.
- Note:** Use shielded twisted-pair cables for digital signals.

Input signal	Output signal
<ul style="list-style-type: none"> Constant frequency selection (DI3)(DI4) Output frequency reference1: 0-10 V (AI1) Stop (0) / Start (1) (DI1) Forward/Reverse selection (DI2) Ramp selection: Ramp1(0)/Ramp2 (DI5) 	<ul style="list-style-type: none"> Analog output AO1: Output frequency Analog output AO2: Motor current Relay output 1: Ready run Relay output 2: Running Relay output 3: Fault (-1)

Install optional modules, if any

See chapter *Electrical installation* in ACP510-01 hardware manual (3AXD50001148140 [EN]).

Start up and use

To start the drive, you need to purchase a separate control panel or BCBL-01 PC (personal computer) programming cable. The following use the basic control panel ACS-BP-S as an example to set the motor data, motor control, connection macro and parameters.

For the detailed information about drive start please refer to the ACP510 Firmware manual (3AXD50001148645 [English]).

For detailed ordering information of the relevant options please refer to the ACP510 Catalogue.

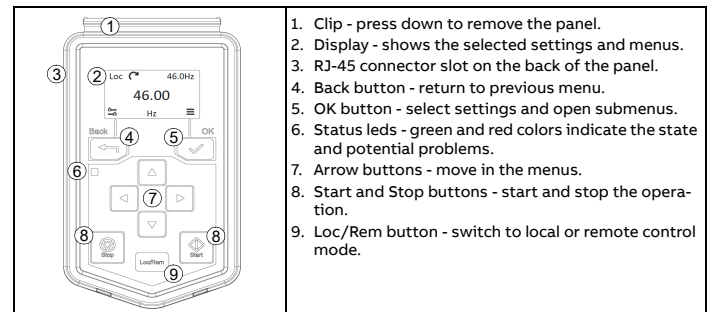

Display

Options menu	Main menu
<ol style="list-style-type: none"> The return button: opens the Options menu. Options menu. Control mode. Rotation direction: forward or reverse. Frequency: Active Frequency: Reference 	<ol style="list-style-type: none"> Main menu Press OK button: opens the Main menu.

The Options menu

	<ol style="list-style-type: none"> Frequency setting Rotation direction - forward or reverse Active faults Active warnings
--	----------------------------------------------------------------------------------------------------------------------------------------------------------------------

Start and stop the drive

To start the drive, press the Start button on the basic control panel. To stop the drive, press the Stop button on the basic control panel.

Change the rotation direction

	<ol style="list-style-type: none"> In the <i>Options</i> menu , Move to the rotation direction item with the arrow buttons. Press the OK button to change the rotation direction.
--	--------------------------------------------------------------------------------------------------------------------------------------------------------------------------------------------------------------------

Set the frequency reference

	<ol style="list-style-type: none"> In the <i>Options</i> menu , move to the frequency reference item with the arrow buttons. Press the OK button to open the item. Press the arrow buttons to set the frequency. Press the OK button to confirm the change.
--	-------------------------------------------------------------------------------------------------------------------------------------------------------------------------------------------------------------------------------------------------------------------------------------------------------

Main menu

	1. Motor data - motor parameters
	2. Motor control - motor curve settings
	3. Control macros - I/O and fieldbus presettings
	4. Diagnostics - faults, warnings, fault log and connection status
	5. Energy efficiency - energy savings
	6. Backup and reset
	7. Parameters

Submenus

The Main menu items have a submenu where you can change settings and set actions. Some submenus also have menus and/or option lists. The content of the submenus depend on the drive type.

Motor data

	1. Nominal power		1. Start mode - Auto, Scan
	2. Nominal current		2. Stop mode - Coast, DC hold, Ramp
	3. Nominal voltage		3. Acceleration time - Automatic, Flying start
	4. Nominal frequency		4. Deceleration time
	5. Nominal speed		5. Maximum allowed speed
	6. Nominal torque		6. Maximum allowed current
	7. Phase order - U V W		7. Minimum allowed speed
	8. Power factor		

Motor control

	1. Normal		2. Ramp
	3. 5.0s		4. 5.0
	5. Max 10rpm		6. Max 3.40
	6. Min		7. rpm

Connection macro

	1. ABB standard macro		1. Present Fault - the fault code is displayed
	2. Hand/Auto		2. Fault History - list of latest fault codes (newest first)
	3. Hand / PID		3. Present Warnings - the warning code is shown
	4. 3-wired		4. I/O status - I/O settings
	5. Alternate macro		
	6. Motor potentiometer macro		
	7. PID control macro		
	8. control panel PID		
	9. PFC		
	10. SPFC		

Diagnose

	1. 1001		2. 2009
	3. 2009		4. I/O

Energy Efficiency

	1. Saved energy in kWh		2. Saved money
	2. Saved energy in MWh		3. Saved money x 1000
	3. Saved money x 1000		4. Cost per kWh
	4. Cost per kWh		
	5. Cost per kWh		

Backup

	1. Backup from the drive to the control panel.
	2. Fully restore the back up from the panel to the drive.
	3. Partly restore the back up from the panel to the drive. A progress view is shown during the backup.

Parameter

	1. Complete parameter list - Groups menu with complete parameters and parameter levels
	2. Modified parameters list - non-default value
	3. Restore the factory default Settings.

Fault and Warning

	The display shows warnings and faults messages if a problem has been detected. A fault message needs your immediate attention.
	1. Identify and eliminate the cause.
	2. For detailed information please refer to the Firmware manual.
	3. Press Reset in the Fault .
	To view the warning messages:
	1. Open the Main menu.
	2. Select Diagnostics .
	3. Scroll down the list if there are multiple warnings.

Drive and panel communication failure

	There is a general communication failure, e.g., the drive does not respond to the panel commands.
	The drive and panel are not compatible, e.g., the drive does not support the basic panel.

Status light

Continuous green		The drive is running normally.
Green, blinking		There is an active warning in the drive.
Red, continuous		There is an active fault in the drive.

List of most commonly used parameters

By default, drive shows short parameter list. For the complete list of parameters, refer to the drive firmware manual.

Par. No.	Par. No.	Settings/Range (default value on bold)
Group 99 Motor data		
99.04	Motor control mode	0...1
99.06	Motor nominal current	0.0...6400.0
99.07	Motor nominal voltage	0.0...960.0
99.08	Motor nominal frequency	0.0 ... 500.0
99.09	Motor nominal speed	0 ... 30000
99.10	Motor nominal power	0.00... 10000.00 kW or 0.00... 13404.83 hp
99.11	Motor nominal cos φ	0.00 ... 1.00
99.12	Motor nominal torque	0.000...4000000.000 N·m or 0.000...2950248.597 lb·ft
99.15	Motor polepairs calculated	0...1000
99.16	Motor phase order	0...1
Group 01 Actual values (read-only)		
01.01	Motor speed used	-30000.00...30000.00
01.06	Output frequency	-500.00...500.00
01.07	Motor current	0.00...30000.00
01.10	Motor torque	-1600.0...1600.0
01.11	DC voltage	0.00...2000.00
01.13	Output voltage	0...2000
01.14	Output power	-32768.00...32767.00
Group 5 Diagnostics (read-only)		
05.02	Run-time counter	0 ... 65535 d
05.11	Inverter temperature	-40.0 ... 160.0 %
Group 10 Standard DI, RO		
10.24	RO1 source	[2] Ready run, [7] Running, [14] Fault, [16] Fault/Warning
10.27	RO2 source	[2] Ready run, [7] Running, [14] Fault, [15] Fault(-1)

10.30	RO3 source	[2] Ready run, [7] Running, [14] Fault, [15] Fault(-1)
Group 12 Standard AI		
12.15	AI1 unit selection	[2]V, [10]mA
12.16	AI1 filter time	0.000...30.000
12.17	AI1 min	-22.000 ... 22.000 mA or V, 0mA or 0V
12.18	AI1 max	-22.000 ... 22.000 mA or V, 20mA or 10V
12.19	AI1 minimum scaled value	-32768.000 ... 32767.000, 0
12.20	AI1 maximum scaled value	-32768.000 ... 32767.000, 50
12.25	AI2 AI2 unit selection	[2]V, [10]mA
12.26	AI2 filter time	0.000...30.000, 0.100 s
12.27	AI2 min	-22.000 ... 22.000 mA or V, 0mA or 0V
12.28	AI2 max	-22.000 ... 22.000 mA or V, 20mA or 10V
12.29	AI2 minimum scaled value	-32768.000 ... 32767.000, 50
12.30	AI2 maximum scaled value	-32768.000 ... 32767.000, 50
Group 13 Standard AO		
13.12	AO1 source	[3]Output frequency, [4]Motor current
13.15	AO1 unit selection	[2]V, [10]mA
13.16	AO1 Filtering time	0.000...30.000
13.17	AO1 source min	-32768.000 ... 32767.000, 0
13.18	AO1 source max	-22.000 ... 22.000 mA or V, 50
13.19	AO1 out at AO1 src min	-22.000 ... 22.000 mA or V, 20mA or 10V
13.20	AO1 out at AO1 src max	-22.000 ... 22.000 mA or V, 20mA or 10V
Group 19 Operation mode		
19.11	Ext1/Ext2 selection	[0]EXT1, [1]EXT2, [3]DI1, [4]DI2, [5]DI3, [6]DI4, [7]DI5, [32]Embedded fieldbus
Group 20 Start/stop/direction		
20.01	Ext1 commands	[0]Not selected, [1]In1 Start, [2]In1 Start;In2 Dir, [3]In1 Start fwd;In2 Start rev, [4]In1P Start;In2 Stop, [5]In1P Start;In2 Stop;In3 Dir, [6]In1P Start fwd;In2P Start rev;In3 Stop, [14]Embedded fieldbus
20.03	Ext1 in1 source	[0]Always off, [2]DI1, [3]DI2, [4]DI3, [5]DI4, [6]DI5
20.04	Ext1 in2 source	[0]Always off, [2]DI1, [3]DI2, [4]DI3, [5]DI4, [6]DI5
20.05	Ext1 in3 source	[0]Always off, [2]DI1, [3]DI2, [4]DI3, [5]DI4, [6]DI5
20.06	Ext2 commands	[0]Not selected, [1]In1 Start, [2]In1 Start;In2 Dir, [3]In1 Start fwd;In2 Start rev, [4]In1P Start;In2 Stop, [5]In1P Start;In2 Stop;In3 Dir, [6]In1P Start fwd;In2P Start rev;In3 Stop, [14]Embedded fieldbus
20.08	Ext2 in1 source	[0]Always off, [2]DI1, [3]DI2, [4]DI3, [5]DI4, [6]DI5, [7]DI6
20.09	Ext2 in2 source	[0]Always off, [2]DI1, [3]DI2, [4]DI3, [5]DI4, [6]DI5
20.10	Ext2 in3 source	[0]Always off, [2]DI1, [3]DI2, [4]DI3, [5]DI4, [6]DI5
20.21	Direction	[0]Request, [1]Forward, [2]Reverse
Group 21 Start/stop mode		
21.02	Magnetization time	0 ... 10000 ms, 500ms
21.03	Stop mode	[0]Coast, [1]Ramp
Group 28 Frequency reference chain		
28.11	Ext1 frequency ref1	[1]AI1 scaled, [2]AI2 scaled, [8]EFB ref1, [9]EFB ref2, [16]PID
28.15	Ext2 frequency ref1	[0]Zero, [1]AI1 scaled, [2]AI2 scaled, [8]EFB ref1, [9]EFB ref2, [16]PID
28.22	Constant frequency sel 1	[0]Always off, [2]DI1, [3]DI2, [4]DI3, [5]DI4, [6]DI5
28.23	Constant frequency sel 2	[0]Always off, [2]DI1, [3]DI2, [4]DI3, [5]DI4, [6]DI5
28.26	Constant frequency1	-500.00 ... 500.00Hz, 5Hz
28.27	Constant frequency2	-500.00 ... 500.00Hz, 10Hz
28.28	Constant frequency3	-500.00 ... 500.00Hz, 15Hz
28.72	Freq acceleration time 1	0.000 ... 1800.000 s, 20s
28.73	Freq deceleration time 1	0.000 ... 1800.000 s, 20s
Group 30 Limits		
30.13	Minimum frequency	-500.00...500.00
30.14	Maximum frequency	-500.00...500.00
30.17	Maximum current	0.00...30000.00
30.19	Minimum torque 1	-1600.0...0.0
30.20	Maximum torque 1	0.0...1600.0
Group 31 Fault functions		
31.11	Fault reset selection	[0]Disable, [2] DI1, [3]DI2, [4]DI3, [5]DI4, [6]DI5
31.12	Auto reset selection	0000h...FFFFh
Group 40 Process PID set 1		
40.07	Process PID operation mode	[0]OFF, [1]ON, [2]ON when drive running
40.08	Set 1 feedback 1 source	[2]AI2 scaled, [8]AI1 percent, [9]AI2 percent
40.16	Set 1 setpoint 1 source	[0]Not selected, [2]Internal setpoint, [11]AI1 percent, [12]AI2 percent
40.24	Set 1 internal setpoint 0	-200000.00 ... 200000.00, 0
40.31	Deviation inversion	[0] Not inverted (Ref-Fbk), [1] Inverted (Fbk-Ref)
40.32	Gain	0.01 ... 100.00, 1.0
40.33	Integration time	0.0 ... 9999.0 s, 60s
Group 45 Energy efficiency		
45.11	Energy optimizer	[0]Disable, [1]Enable
Group 58 Embedded fieldbus		
58.01	Protocol enable	[0]None, [1]ModbusRTU
58.03	Node address	0 ... 255, 1
58.04	Baud rate	[1]4800, [2]9600, [3]19200, [4]38400, [5]57600, [6]76800, [7]115200
58.05	Parity	[0]NONE 1, [1]NONE 2, [2]EVEN 1, [3]ODD 1, [28] EVEN 1
58.06	Communication control	[0]Enabled, [1]Refresh settings
58.14	Communication loss action	[0]No action, [1]Fault, [2]Last speed, [5]Warning
Group 76 PFC configuration		
76.01	PFC status	0000h...FFFFh
76.02	PFC system status	0...3, 100...103, 200...202, 300...302, 400, 500, 600, 700, 800...801, 4...9
76.11	Pump status 1	0000h...FFFFh
76.12	Pump status 2	0000h...FFFFh
76.21	PFC configuration	
76.30	Start point 1	0.00...32767.00
76.41	Stop point 1	0.00...32767.00
Group 77 PFC maintenance and monitoring		
77.10	PFC runtime change	-
77.11	Pump 1 running time	0.00...42949672.95
77.12	Pump 2 running time	0.00...42949672.95
77.13	Pump 3 running time	0.00...42949672.95
77.14	Pump 4 running time	0.00...42949672.95
Group 96 System		
96.01	Language	[0]Not selected, [1033]EN, [2052]CN
96.04	Marco selection	[0]Finalization, [1] ABB standard macro, [2] Hand/Auto macro, [3] Hand/PID macro, [11]3-wire macro, [12]Alternate macro, [13]Motor potentiometer macro, [14] PID control macro, [15] control panel PID, [16]PFC, [18]SPFC
96.06	Parameter restore	[0]Finalization [34560]Restore defaults

Warnings and faults

Warning	Fault	Aux. code	Description
A2A1	2281	Current calibration	Warning: Current offset and gain measurement calibration will occur at next start. Fault: Output phase current measurement fault.
A2B1	2310	Overcurrent	Output current has exceeded internal fault limit. In addition to an actual overcurrent situation, this warning may also be caused by an earth fault or supply phase loss.
A2B3	2330	Earth leakage	Drive has detected load unbalance typically due to earth fault in motor or motor cable.
A2B4	2340	Short circuit	Short-circuit in motor cable(s) or motor.
-	3130	Input phase loss	Intermediate circuit DC voltage is oscillating due to missing input power line phase or blown fuse.
-	3181	Wiring or earth fault	Incorrect input power and motor cable connection (ie. input power cable is connected to drive motor connection).
A3A1	3210	DC link overvoltage	Intermediate circuit DC voltage too high (when the drive is stopped).
A3A2	3220	DC link undervoltage	Intermediate circuit DC voltage too low (when the drive is stopped).
-	3381	Output phase loss	Motor circuit fault due to missing motor connection (all three phases are not connected).
A7CE	6681	EFB comm loss	Communication break in embedded fieldbus (EFB) communication.
A7C1	7510	FBA A communication	Cyclical communication between drive and fieldbus adapter module A or between PLC and fieldbus adapter module A is lost.
A7AB	-	Extension I/O configuration failure	Installed C-type module is not the same as configured or the communication between the drive and module has been disturbed.
AFF6	-	Identification run	Motor ID run will occur at next start.

Ratings, fuses and power cable dimensions

ACP510-01	Ratings			Fuses		Typical power cable sizes, Cu		Frame size
	input current (A)	output current (A)	Motor power (kW)	gG Fuses (IEC 60269)	uR/aR Fuses (DIN 43620)	mm ²	AWG	
02A7-4	2.6	2.6	0.75	OFAF000H4	170M1561	3x1.5 + 1.5	16	R1
03A4-4	3.3	3.3	1.1	OFAF000H6	170M1561	3x1.5 + 1.5	16	R1
04A1-4	4.0	4.0	1.5	OFAF000H6	170M1561	3x1.5 + 1.5	16	R1
05A7-4	5.6	5.6	2.2	OFAF000H10	170M1561	3x1.5 + 1.5	16	R1
07A3-4	7.2	7.2	3.0	OFAF000H10	170M1561	3x1.5 + 1.5	16	R1
09A5-4	9.4	9.4	4.0	OFAF000H16	170M1561	3x2.5 + 2.5	14	R1
12A7-4	12.6	12.6	5.5	OFAF000H16	170M1561	3x2.5 + 2.5	14	R1
018A-4	17.0	17.0	7.5	OFAF000H25	170M1563	3x2.5 + 2.5	14	R2
026A-4	25.0	25.0	11.0	OFAF000H32	170M1563	3x6 + 6	10	R2
033A-4	32.0	32.0	15.0	OFAF000H40	170M1565	3x10 + 10	8	R3
039A-4	38.0	38.0	18.5	OFAF000H50	170M1565	3x10 + 10	8	R3
046A-4	45.0	45.0	22.0	OFAF000H63	170M1566	3x10 + 10	8	R3
062A-4	62	62	30	OFAF000H80	170M1567	3x25 + 16	4	R4
073A-4	73	73	37	OFAF000H100	170M1568	3x25 +		