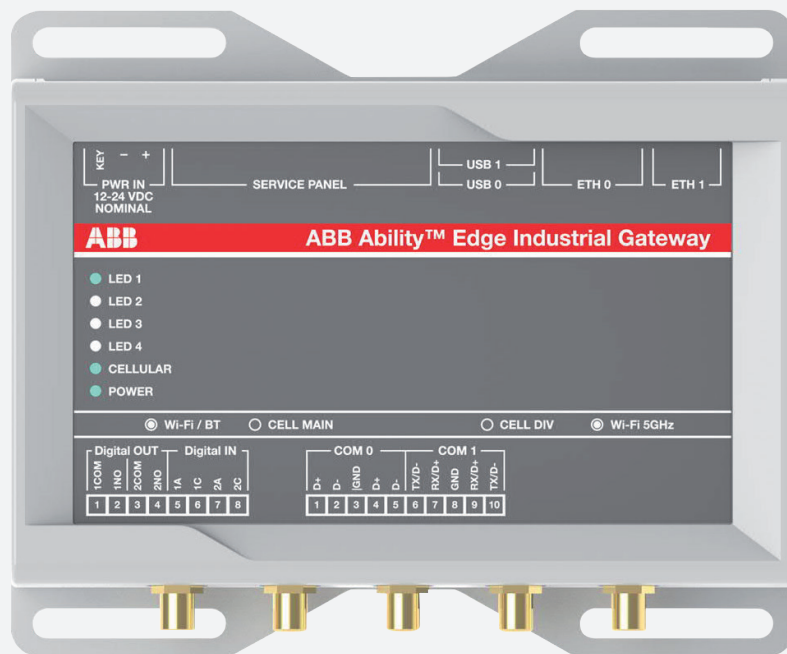


USER MANUAL

# ABB Ability™ Edge Industrial Gateway





---

## Trademarks

All trademarks, registered trademarks, logos, trade names, products names contained in this document are the property of their respective owners.

---

## Intended audience of this document

This document is intended for system integrators: skilled persons with a thorough knowledge in linking together, physically or functionally, different computing systems and software applications to operate as a coordinated whole in compliance with the applicable regulations.

---

## Revision history

Revision  
0-1 Preliminary release July 2020  
0-2 Market release 2020





# ABB Ability™ Edge Industrial Gateway Index

INTRODUCTION	1
CONVENTIONS USED IN THIS DOCUMENT	2
PRODUCT OVERVIEW	3
NORMS AND CERTIFICATIONS	4
INTERFACES OVERVIEW	5
INTERFACES IN DETAIL	6
MECHANICAL SPECIFICATIONS	7
HOW TO INSTALL THE PRODUCT	8
HOW TO SUPPLY POWER TO THE PRODUCT	9
HOW TO MAINTAIN THE PRODUCT	10
BASIC CONFIGURATION VIA CLOUD COMMISSIONING TOOL	11
ANNEX 1: ADDITIONAL I/O MODULE	12
DECLARATION OF CONFORMITY	13
MECHANICAL SPECIFICATIONS HOW TO INSTALL THE PRODUCT	14
BASIC CONFIGURATION VIA PROVISIONING TOOL	15
ANNEX 2: WEB SERVER CONFIGURATION (LOCAL VIEW)	16





---

# Introduction

## **1.1 Contents**

1.1.1 Overview

1.1.2 Recipients

## **1.2 Safety**

1.2.1 Safety prescriptions

1.2.2 Warnings

## **1.3 Cybersecurity**

1.3.1 Disclaimer

1.3.2 TCP/IP based protocols and used IP ports

## **1.4 Warning messages used in this document**

1.4.1 Warning messages for harm to persons

1.4.2 Warning messages for damage to property

## **1.5 Warning: power supply safety**

## **1.6 Caution: wireless safety**



# Introduction

## 1.1 Contents

### 1.1.1 Overview

This manual describes the characteristics of the ABB Ability™ Edge Industrial Gateway.

### 1.1.2 Recipients

In accordance with standard IEC 60050, this manual is aimed at two user profiles:

- Expert persons, in electric environment (IEV 195-04-01): persons with sufficient training and experience to enable them to perceive the risks and avoid the hazards potentially created by electricity.
- Persons trained in an electrical environment (IEV 195-04-02): persons suitably informed or supervised by electrical technicians to enable them to perceive the risks and avoid the hazards potentially created by electricity.



#### IMPORTANT

In this manual the tasks are specifically indicated that can be performed by trained persons in an electrical environment. All the remaining tasks described in the manual must be performed by trained persons in an electrical environment.

ABB accepts no liability for damage to property or personal injury due to failure to comply with the instructions contained in this document.

## 1.2 Safety

### 1.2.1 Safety prescriptions



**HARZARD! ELECTRIC SHORK RISK!** In the case of persons who are not authorized to work on pants carrying live voltage in accordance with local legislation, in order to avoid any potential electrical risk during assembly, installation, maintenance or removal of the ABB Ability™ Edge Industrial Gateway from service, disconnect or lock out all electrical supplies.

**WARNING!**

- Detailed descriptions of the standard installation, use and maintenance procedures and principles for operating in safety are not included: it is important to note that this document contains safety and caution indications against certain methods (of installation, use and maintenance) that could harm persons, damage devices or make them less safe.
- These warnings and alarms do not encompass all conceivable installation, use and maintenance methods recommended or not recommended by ABB that could be applied and possible consequences and complications of each conceivable method. Neither will ABB investigate all these methods.
- Anybody who used maintenance procedures or devices, recommended by ABB or not has to check thoroughly that neither personal safety nor safety devices are placed in danger by the installation method, use, maintenance or by the instruments used; for further information, explanations or specific problems contact the nearest ABB.
- This manual has been written only for qualified persons and is not to be intended as substitute for a suitable course or experience with the safety procedures for this device.
- For products provided with communication, the purchaser, the installer or the final customer are responsible for applying all the IT security measures to prevent risks arising from the connection to communications networks; these risks comprise amongst other things the use of the product by unauthorized persons, the alterations of its normal operation, access to and modification of information.
- The purchaser, the installer or the final customer and person responsible for ensuring that safety warnings and notices are displayed and also that all the access points and operating devices are safely locked when the switchgear is left unattended.
- All the information contained in this document is based on the latest information available at the moment of publication. We reserve the right to modify the document at any moment without prior notice.

## 1.2.2 Warnings

**WARNING!**

READ THE FOLLOWING MANUAL CAREFULLY BEFORE INSTALLING OR WORKING ON EDGE INDUSTRIAL GATEWAY

- Keep this manual carefully with all the other available documents, including: Getting Started for first installation, electrical diagrams, drawings and any descriptive notes.
- Keep these documents available during the ABB Ability™ Edge Industrial Gateway installation, operating and maintenance step to facilitate the following operations.
- Install the unit in compliance with the environmental, electrical and mechanical limits described in the product documentation.
- ABB Ability™ Edge Industrial Gateway has been designed to operate with voltage and current values within the rated limits: do not install in systems that work at values exceeding these rated limits.
- Follow the safety procedures set by your company.
- Do not open lids or doors, do not work on devices before disconnecting all circuits and checking that they are disconnected with a measuring instrument.



## 1.3 Cybersecurity

### 1.3.1 Disclaimer

It is the sole responsibility of the customer to provide and continuously ensure a secure connection between the product and the customer network or any other network. The customer is required to establish and maintain any appropriate measures (including but not limited to the installation of firewalls, application of authentication measures, encryption of data, installation of anti-virus programs, etc.) to protect the product, the network, its system and the interface against any kind of security breach, unauthorized access, interference, intrusion, leakage and/or theft of data or information. ABB and its affiliates are not liable for damage and/or losses related to such security breaches, unauthorized access, interference, intrusion, leakage and/or theft of data or information.

### 1.3.2 TCP/IP based protocols and used IP ports

To set up an IP firewall the following table summarizes the IP ports used by the device.

Interface	Port	Type	Default state	Description
ETH0/Wi-Fi/Cellular	53	UDP	Closed/Outbound	DNS (Name resolution)
ETH0/Wi-Fi/Cellular	123	UDP	Closed/Outbound	NTP (Time synchronization)
ETH0/Wi-Fi/Cellular	443	TCP	Closed/Outbound	HTTPS (firmware update from cloud)
ETH1	22	TCP	Closed/Inbound	SSH (ABB maintenance access)
ETH1	5001	TCP	Open/Inbound	HTTPS (fProvisioning Tool)
ETH1	5003	TCP	Open/Inbound	HTTPS (Web server)
ETH1	53	UDP	Open/Inbound	DNS (Name resolution)
ETH1	67	UDP	Open/Inbound	DHCP (Dynamic IP)
ETH1	68	UDP	Open/Inbound	DHCP (Dynamic IP)
ETH1	502	TCP	Open/Inbound	Modbus TCP (Device configuration)
ETH1	502	TCP	Closed/Outbound	Modbus TCP (Field devices communication)

For further details on cybersecurity, please refer to [Cyber Security Deployment Guideline section](#)

Modbus protocol is not secure as such. When this protocol is used, eavesdroppers on the local network are able to understand the communication exchange happening with the device

## 1.4 Warning messages used in this document

### 1.4.1 Warning messages for harm to persons

To indicate an imminently hazardous situation which, if not avoided, will result in death or serious injury, the following message is used:



#### **DANGER!**

Sign (if necessary)

**TEXT THAT EXPLAINS THE HAZARD AND THE CONSEQUENCES OF NOT AVOIDING IT**

**Text that explains how to avoid this hazard**

To indicate a potentially hazardous situation which, if not avoided, could result in death or serious injury, the following message is used:



#### **WARNING!**

Sign (if necessary)

**TEXT THAT EXPLAINS THE HAZARD AND THE CONSEQUENCES OF NOT AVOIDING IT**

**Text that explains how to avoid this hazard**



To indicate a potentially hazardous situation which, if not avoided, could result in minor or moderate injury, the following message is used:

**CAUTION!**

Sign (if necessary)

**TEXT THAT EXPLAINS THE HAZARD AND THE CONSEQUENCES OF NOT AVOIDING IT****Text that explains how to avoid this hazard**

## 1.4.2 Warning messages for damage to property

To indicate potential risks of damage to the supported product (or to other property), the following message is used:

**NOTICE**

Sign (if necessary)

**Text that explains how to avoid damaging the supported product (or other property)**

## 1.5 Warning: power supply safety

**WARNING!****ELECTRIC SHOCK HAZARD**

Failure to supply power correctly or to follow all operating instructions correctly, may create an electric shock hazard, which could result in personal injury or loss of life, and / or damage the equipment or other property.

To avoid injuries and safely supply power to the product, complete the following steps:

1. Observe all the instructions for safety, installation, and operation.
2. Make sure your hands are dry.
3. Make sure that all the cables used:
  - Are in good condition before using them.
  - Meet the product requirements and comply with the relevant standards and regulations.
4. Position cables with care. Do not position cables in places where they may be trampled or compressed by objects placed on them.
5. Make sure that the power-points and plugs are in good condition before using them
6. Do not overload the power-points and plugs.
7. Make sure that the product maintains a proper grounding connection.
8. Use a power supply that meets the product requirements and complies with the relevant standards and regulations.
9. Connect power after the installation of the system has been completed.
10. Never connect or disconnect the cables with the system or the external apparatus switched ON.

## 1.6 Caution: wireless safety

The antennas used in the product have to be installed with care, to avoid any interference with other electronic devices and to guarantee a minimum distance from the body (20 cm). In case of this requirement cannot be satisfied, the system integrator has to assess the final product against the SAR regulation.





---

# Conventions used in this document

- 2.1 Conventions for signal names**
- 2.2 Conventions for signal types**



# Conventions used in this document

## 2.1 Conventions for signal names

Convention	Description
GND	Ground
#	Active low signal
+	Positive signal; Positive signal in differential pair
-	Negative signal; Negative signal in differential pair
3.3	3.3 V signal level
5	5 V signal level
NC	No Connection
Reserved	Use is reserved to ABB



---

## 2.2 Conventions for signal types

Convention	Description
I	Signal is an input to the system
O	Signal is an output from the system
IO	Signal may be input or output
P	Power and Ground
A	Analog signal
NC	No Connection
Reserved	Use is reserved to ABB





---

# Product overview

## **3.1 Product description**

## **3.2 Intended use and not allowed uses of the product**

### 3.2.1 Intended use

## **3.3 Technical specifications**

## **3.4 Product labels**



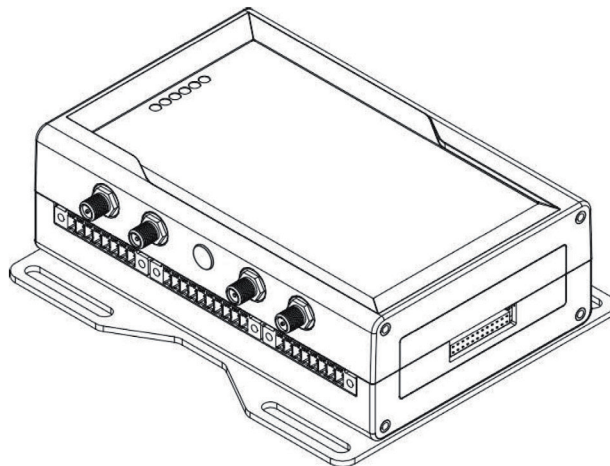
# Product overview

## 3.1 Product description

The ABB Ability™ Edge Industrial Gateway is a IoT Gateway designed to deliver LTE connectivity with 3G/4G fallback to industrial and lightly rugged applications.

ABB Ability™ Edge Industrial Gateway is an independent IoT gateway which can gather data from field devices – as well as consumption of water and gas, among others – and connect the system to ABB Ability™ Energy and Asset Manager, our cloud platform. As a result, all downstream field devices can be monitored from the cloud via an Ethernet cable, wi-fi or mobile connectivity.

Figure 1  
The features availability depends on the product versions



## 3.2 Intended use and not allowed uses of the product

The product is intended for professional use and must be installed by qualified personnel only. The product must be installed in a secured location, accessible to authorized personnel only (for example in a cabinet / technical compartment).

### 3.2.1 Intended use

The ABB Ability™ Edge Industrial Gateway must:

- Be installed in a secured location, only accessible to authorized personnel (for example in a cabinet / technical compartment), and not exposed to atmospheric agents.
- Be used indoors only.
- Be used with appropriate interconnecting and power cables.
- Be used with an external DC power supply source that:
  - Must meet the requirements stated on the identification label of the product.
  - Must deliver a maximum current of 2 A.
  - Must include an external 2 A fuse on the line coming from the negative terminal.



### 3.3 Technical specifications

The ABB Ability™ Edge Industrial Gateway family is available in the following versions:

- ABB Ability™ Edge Industrial Gateway standard version.
- ABB Ability™ Edge Industrial Gateway with 3G Europe (EU)\*.
- ABB Ability™ Edge Industrial Gateway with 3G North America (NA)\*.

—  
\*  
cellular is reserved  
for future usag

Specifications	Description According to Product Versions			
	ABB Ability™ Edge Industrial Gateway standard version	ABB Ability™ Edge Industrial Gateway with 3G NA	ABB Ability™ Edge Industrial Gateway with 3G EU	
Processor			TI AM3352, 1 GHz, 1 Core	
Memory	RAM		1 GB, DDR3	
Storage	Embedded		8 GB eMMC	
Wired Interfaces	Ethernet		2x Fast Ethernet on RJ45 connectors	
	USB	3x Host 2.0 (noise and surge protected) on Type A connectors		
	Serial		1x RS-485: COM 0; Surge protected, Insulated	
			1x RS-232/485: COM 1; Surge protected, RS-485 termination and fail-safe resistors	
	Digital I/O (currently not supported)		2x Digital Input: 36 V, 1 kV Optoinsulate	
	Expansion		2x Digital Output: 40 V AC/DC, 1 kV Optoinsulated, 500 mA, 1 kHz Max Switching	
Wireless Interfaces	Internal Cellular Modem	No	LTE Cat 1 (NA) 3G Fallback	
	Wi-Fi/Bluetooth		802.11a,b,g,n / BLE 4.2	
	Antennas (external)	2x RP-SMA Wi-Fi/ Bluetooth	2x SMA Cellular 2x RP-SMA Wi-Fi/Bluetooth	

Specifications	Description According to Product Versions			
	ABB Ability™ Edge Industrial Gateway standard version	ABB Ability™ Edge Industrial Gateway with 3G NA	ABB Ability™ Edge Industrial Gateway with 3G EU	
Other	RTC		Yes (backup supercap)	
	Watchdog		Yes (system level)	
	TPM		TPM 2.0	
	Sensors		Temperature (inside the product)	
	LEDs			1x Power
				1x Cellular Connection
				4x Customized Functions
	Buttons			1x Reset
				1x Factory reset
	SIM Card Holder			MicroSIM card holder
Input		Nominal: 12 or 24 VDC; Range: 9 to 30 VDC with transient protection		
Power	Consumption		4 W typical; 15 W maximum	
	Operating Temperature		-40 to +70 °C <sup>(2)</sup>	
Environment	Storage Temperature		-40 to +85 °C	
	Relative Humidity		5 to 95% (non-condensing) at +40°C	

—  
(2)  
Software ensures that  
the system doesn't exceed  
the maximum operating  
temperature (+70 °C)



### 3.4 Product labels

The following labels are placed on the product:

—  
\*  
the symbol stands for direct current

Label example	Label type and content	Label position
<p> <b>ABB</b> Ability Edge Industrial Gateway <b>EUROTECH</b>                      Manufacturer: Eurotech SpA Via F.lli Sestri 3/a 20020 Amara (PO) - ITALY                      Product: ReliEGATE 10-12 CONTAINS FCC ID: UJUNMRG1012                      Model: REGATE-10-12-55-CS07 CONTAINS IC: 21443-MRG1012                      INPUT: 12-24V ~ 15W CONTAINS FCC ID: R07LE910NAV2                      Made in Taiwan CONTAINS IC: S131A-LE910NAV2                      CAN ICES-3 (B)/NMB-3(B)                 </p>	<b>Part Number Label</b> ABB and Eurotech logo Manufacturer name Manufacturer address (EU versions only) Product number Model number (xx = product version) Power supply specifications* FCC information (US versions only) ISED information (NA versions only)	On the underside of the product
<p>                     SERIAL: PPAAMD10000                      MAC ID ETH0: D43639123A25                      MAC ID ETH1: D43639003D76                      IMEI: 356961079700459                      FC                 </p>	<b>Serial Number Label</b> Serial number MAC ID number IMEI number CE mark (EU versions only) FCC mark (EU versions only) WEEE symbol (EU versions only)	On the underside of the product
<p> <b>ABB</b> ABB Ability™ Edge Industrial Gateway                      LED 1                      LED 2                      LED 3                      LED 4                      CELLULAR                      POWER                      WAP/RT CELL MGMT CELL DIV WIP/SMU                 </p>	<b>Topside Label</b> ABB logo ABB product name Interfaces name	On the top side of the product
<p>                     ABB SIN:                      8AY123456789S000                      Activation code:                      1234567890123456                 </p>	<b>ABB Serial Number Label</b> ABB serial number Activation code	On the left side of the product







# Norms and certifications

## **4.1 CE Marking**

## **4.2 Directive RED 2014/53/EU**

4.2.1 Modification statement

## **4.3 FCC Marking**

## **4.4 FCC/ISED regulatory notices**

4.4.1 Modification statement

4.4.2 ISED Canada regulatory notices

4.4.3 RF radiation exposure statement

4.4.4 FCC class B digital device notice

4.4.5 ISED class B digital device notice

4.4.6 Labeling information

## **4.5 Restrictions on 5 GHz Wi-Fi usage**

4.5.1 EU restrictions on 5 GHz Wi-Fi usage

4.5.2 FCC restrictions on 5 GHz Wi-Fi usage

## **4.6 Antennas list**

## **4.7 RoHS 3 compliance**

## **4.8 REACH compliance**

## **4.9 WEEE compliance**



---

# Norms and certifications

---

## 4.1 CE Marking

Some versions of the product described in this document are CE marked; for more information see “Technical Specifications” on page 19.

ABB is not responsible for the use of this product together with equipment (for example: power supplies, personal computers, etc.) that are not CE marked and not compliant with the requirements specified in this document.

---

## 4.2 Directive RED 2014/53/EU

Some versions of the product described in this document meet the requirements of the Directive 2014/53/EU of the European Parliament and of the Council of 16 April 2014 on the harmonization of the laws of the Member States relating to the making available on the market of radio equipment. For more information see “Technical Specifications” on page 19.

### 4.2.1 Modification statement

ABB has not approved any changes or modifications to this product by the user. Any changes or modifications could void the user’s authority to operate the product.

---

## 4.3 FCC Marking

Some versions of the product described in this document are FCC marked; for more information see “Technical Specifications” on page 19.

ABB is not responsible for the use of this product together with equipment (for example: power supplies, personal computers, etc.) that are not FCC marked and not compliant with the requirements specified in this document.

---

## 4.4 FCC/ISED regulatory notices

### 4.4.1 Modification statement

ABB has not approved any changes or modifications to this product by the user. Any changes or modifications could void the user’s authority to operate the product.



## 4.4.2 ISED Canada regulatory notices

This device contains licence-exempt transmitter(s)/receiver(s) that comply with Innovation, Science and Economic Development Canada's licence-exempt RSS(s). Operation is subject to the following two conditions:

1. This device may not cause interference.
2. This device must accept any interference, including interference that may cause undesired operation of the device.

This radio transmitter 21442-MRG1012 has been approved by Innovation, Science and Economic Development Canada to operate with the antenna types listed below, with the maximum permissible gain indicated. Antenna types not included in this list that have a gain greater than the maximum gain indicated for any type listed are strictly prohibited for use with this device.

Antenna Types	Frequency Band	Antenna Gain
Cellular 50Ω Dipole	700 MHz	6.63 dBi
	850 MHz	6.63 dBi
	1700 MHz	6.00 dBi
	1900 MHz	8.51 dBi
Wi-Fi / Bluetooth 50Ω Dipole	2.5 GHz Wi-Fi 802.11a,b,g,n / BLE 4.2 BLE Bluetooth 5 GHz Wi-Fi 802.11a,b,g,n	5.47 dBi 7.07 dBi

The ABB Ability™ Edge Industrial Gateway has been certified with the following antennas:

Types	Manufacturer and Model	Bands	Peak Gain (dBi)	VSWR
	Linx Technologies ANT-DB1-RAF-RPS	2.40–2.483 MHz	2.5/ 4.6	<1.9
		5.15–5.825 GHz		
Wi-Fi/BT	2J Antennas 2J6302MP	2410-2490 MHz	1.7/ 2.3 (2m cable)	1.6/ 1.5
		4920-5925 MHz		
	Taoglas GSA.8827.A.101111	698-960 MHz	1.8/ 3/ 4.7	-
		1710-2170 MHz		
		2500-2700 MHz		
	2J Antennas 2JW0124-C868B	698-960 MHz	0.5 / 2.5 / 1.5	2.5 / 1.5 / 2.6
		1710-2170 MHz		
		2500-2700 MHz		
	2J Antennas 2J3024M	698-960 MHz	1.0 / 2.4 / 2.1 (2m cable)	1.9 / 1.5 / 1.3
		1710-2170 MHz		
		2500-2700 MHz		
Cellular	2J Antennas 2J5424P	698-960 MHz	1.8 / 2.4 / 2.1 (2m cable)	2.7 / 2.1 / 2.0
		1710-2170 MHz		
	Taoglas AA.107.301111	574-1602 MHz	-	N.A.
GNSS	2J Antennas 2J4301MPGF	1575.42-1606 MHz	-	N.A.

## 4.4.3 RF radiation exposure statement

This product complies with FCC and ISED radiation exposure limits set forth for an uncontrolled environment. The antenna should be installed and operated with minimum distance of 20 cm between the radiator and your body.

This device and its antenna(s) must not be co-located or operating in conjunction with any other antenna or transmitter except in accordance with FCC multi-transmitter product procedures.

## 4.4.4 FCC class B digital device notice

This device complies with part 15 of the FCC Rules. Operation is subject to the following two conditions:

1. This device may not cause harmful interference, and this product must accept any interference received, including interference that may cause undesired operation.
2. This device must accept any interference received, including interference that may cause undesired operation.

Note: This equipment has been tested and found to comply with the limits for a Class B digital device, pursuant to part 15 of the FCC Rules. These limits are designed to provide reasonable protection against harmful interference in a residential installation. This product generates, uses and can radiate radio frequency energy and, if not installed and used in accordance with the instructions, may cause harmful interference to radio communications.



However, there is no guarantee that interference will not occur in a particular installation. If this product does cause harmful interference to radio or television reception, which can be determined by turning the product OFF and ON, the user is encouraged to try to correct the interference by one or more of the following measures:

- Reorient or relocate the receiving antenna.
- Increase the separation between the product and the receiver.
- Connect the product into an outlet on a circuit different from that to which the receiver is connected.
- Consult the dealer or an experienced radio/TV technician for help.

#### 4.4.5 ISED class B digital device notice

ICES-003 Class B Notice - Avis NMB-003, Classe B.

This Class B digital apparatus complies with Canadian ICES-003.

Cet appareil numérique de la classe B est conforme à la norme NMB-003 du Canada.

#### 4.4.6 Labeling information

The following information is stated on the product labels:

- Contains FCC ID: RI7LE910NAV2.
- Contains FCC ID: UKMMRG1012.
- Contains IC ID: 5131A-LE910NAV2.
- Contains IC ID: 21442-MRG1012.
- CAN ICES-3 (B)/NMB-3(B).

### 4.5 Restrictions on 5 GHz Wi-Fi Usage

Channel Number	Frequency (MHz)	Europe (ETSI)	North America (FCC)
36	5180	Indoor Usage Only	Indoor Usage Only
40	5200	Indoor Usage Only	Indoor Usage Only
44	5220	Indoor Usage Only	Indoor Usage Only
48	5240	Indoor Usage Only	Indoor Usage Only
52	5260	Not Supported	Not Supported
56	5280	Not Supported	Not Supported
60	5300	Not Supported	Not Supported
64	5320	Not Supported	Not Supported
100	5500	Not Supported	Not Supported
104	5520	Not Supported	Not Supported
108	5540	Not Supported	Not Supported
112	5560	Not Supported	Not Supported
116	5580	Not Supported	Not Supported
120	5600	Not Supported	Not Supported
124	5620	Not Supported	Not Supported
128	5640	Not Supported	Not Supported
132	5660	Not Supported	Not Supported
136	5680	Not Supported	Not Supported
140	5700	Not Supported	Not Supported
149	5745	Not Supported	Supported
153	5765	Not Supported	Supported
157	5785	Not Supported	Supported
161	5805	Not Supported	Supported
165	5825	Not Supported	Supported



### 4.5.1 EU restrictions on 5 GHz Wi-Fi usage

Due to EU restrictions on 5 GHz Wi-Fi bands the ABB Ability™ Edge Industrial Gateway is limited to indoor operation and should only be operated in the frequency band 5150 MHz – 5250 MHz (U-NII-1) covering 20 MHz channels (36,40,44,48) and 40 MHz channels(38,46). Dynamic Frequency selection (DFS) as master or slave is not supported by the ABB Ability™ Edge Industrial Gateway.

### 4.5.2 FCC restrictions on 5 GHz Wi-Fi usage

Due to FCC restrictions on 5 GHz Wi-Fi bands the ABB Ability™ Edge Industrial Gateway is limited to indoor operation within the frequency band 5150 MHz – 5250 MHz (U-NII-1) covering 20 MHz channels (36,40,44,48) and 40 MHz channels(38,46). Dynamic Frequency selection (DFS) as master or slave is not supported by the ABB Ability™ Edge Industrial Gateway.

## 4.6 Antennas list

The ABB Ability™ Edge Industrial Gateway has been certified with the following antennas:

Antenna Types	Manufacturer and Part Number
Wi-Fi / Bluetooth	Linx Technologies ANT-DB1-RAF-RPS Taoglas MA950.W.A.LBICG.005
Cellular	Taoglas GSA.8827.A.101111 Taoglas MA950.W.A.LBICG.005

### NOTICE

**Within the EU, antennas have to be used in compliance with the RED requirements. Within the US/ Canada, antennas have to be used in compliance with the FCC/ISED requirements.**

## 4.7 RoHS 3 compliance

The product, including all its components and its sub-assemblies, have been manufactured in compliance with the Directive 2011/65/EU of the European Parliament and of the Council of 8 June 2011 on the restriction of the use of certain hazardous substances in electrical and electronic equipment.

## 4.8 REACH compliance

The product is certified according to the REACH Directive, taking in account Substances of Very High Concern (SVHC), as specified in the list published by ECHA (European Chemical Agency) at the time of the design.

## 4.9 WEEE compliance

In compliance with the Directive 2012/19/EU of the European Parliament and of the Council of 4 July 2012 on waste electrical and electronic equipment (WEEE), the symbol on the right, shown on the product or within its literature, indicates separate collection for electrical and electronic equipment (EEE) that has been placed on the market after 2005. The product, at the end of its life cycle, must be collected separately and managed in accordance with the provisions of the current Directive on waste of electrical and electronic equipment. Because of the substances present in the product, improper disposal can cause damage to human health and to the environment. To avoid any possible legal implications, contact your local waste collection body for full collect and recycling information.







# Interfaces overview

- 5.1 Front side interfaces overview**
- 5.2 Rear side interfaces overview**
- 5.3 Service panel interfaces**
- 5.4 Right side interface overview**
- 5.5 Left side interface overview**
- 5.6 LED indicators overview**



# Interfaces overview

## 5.1 Front side interfaces overview

The Front Side Interfaces are as follows:

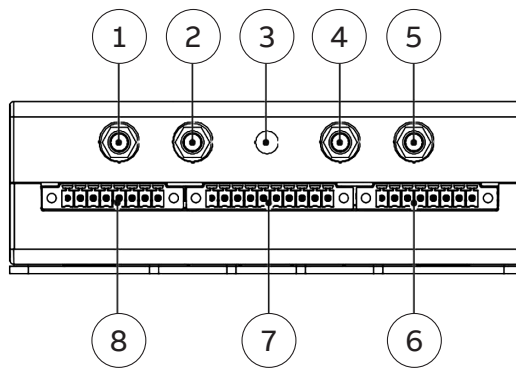


Figure 2  
Front Side Interfaces  
Layout

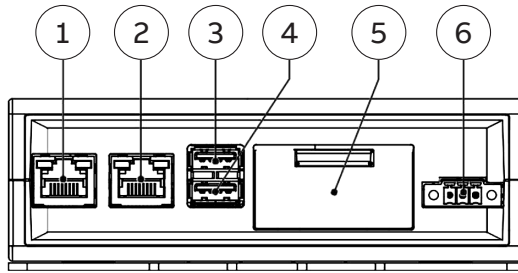
Ref#	Description
1	Antenna connector for 2.4 GHz Wi-Fi / Bluetooth
2	Main antenna connector for Internal Cellular Modem: CELL MAIN (only for ABB Ability™ Edge Industrial Gateway with 3G)
3	Reserved
4	Diversity antenna connector for Internal Cellular Modem: CELL DIV (only for ABB Ability™ Edge Industrial Gateway with 3G)
5	Antenna connector for 5 GHz Wi-Fi
6	Not available
7	COM 0/1 connector
8	Digital I/Os connector



## 5.2 Rear side interfaces overview

The Rear Side Interfaces are as follows:

Figure 3  
Rear Side Interfaces  
Layout

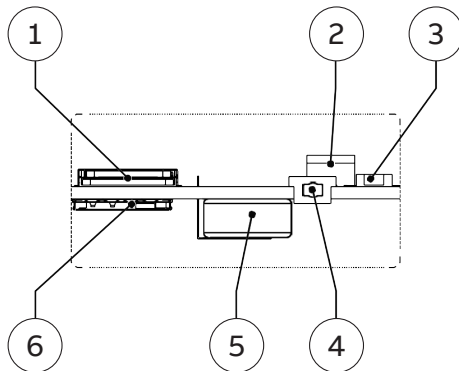


Ref#	Description
1	Ethernet ETH 1 connector (Local LAN)
2	Ethernet ETH 0 connector
3	USB 0 connector
4	USB 1 connector
5	Service Panel
6	Power IN connector

## 5.3 Service panel interfaces

The Interfaces available in the Service Panel are as follows:

Figure 4  
Service Interfaces layout



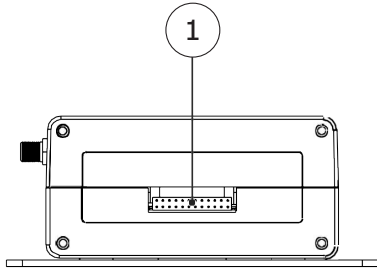
Ref#	Description
1	MicroSD. The MicroSD card holder is disabled.
2	DIP-switch for serial ports configuration
3	Pushbutton
4	Hardware reset push button
5	RTC backup supercap (not removable)
6	MicroSIM card holder (push-pull)



### 5.4 Right side interface overview

The Right Side Interface is as follows:

Figure 5  
Right Side Interfaces  
Layout

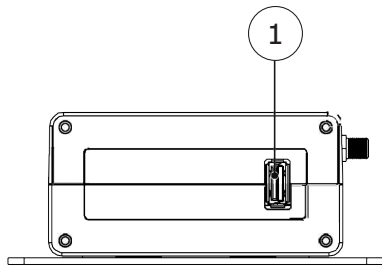


Ref#	Description
1	Expansion connector

### 5.5 Left side interface overview

The Left Side Interface is as follows:

Figure 6  
Left Side Interface Layout



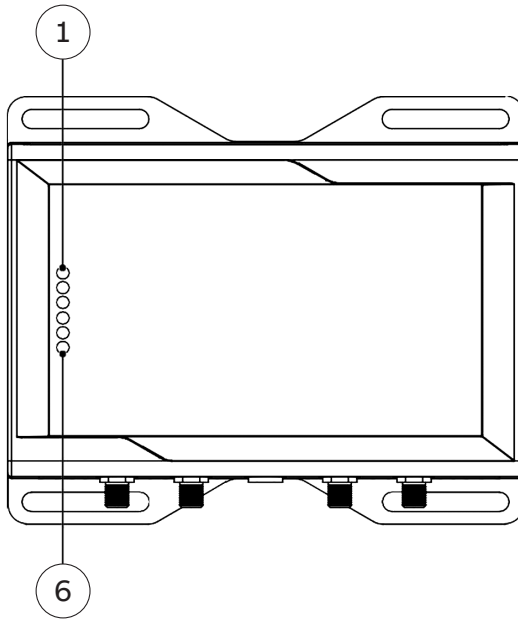
Ref#	Description
1	2.0 Host USB connector (ready to interface optional USB storage)



## 5.6 LED indicators overview

The LED Indicators are as follows:

Figure 7  
LED Indicators Layout



Ref#	Use and Status	Color
1	LED 1: Cloud Connection LED ON: Connection OK LED OFF: No connection after 3 attempts	Green
2	LED 2: Fieldbus Data Collection LED Blinking: Data collection in progress LED OFF: No data collection	Green
3	LED 3: FW Update LED ON: FW Update Error LED Blinking: Update in progress	Amber
4	LED 4: System Status LED OFF: System OK LED ON: Error	Amber
5	N/A (ABB Ability™ Edge Industrial Gateway std version) CELLULAR (ABB Ability™ Edge Industrial Gateway with 3G) LED ON: Internal Cellular Modem ON LED Blinking: Internal Cellular Modem connected to cellular network	Green
6	POWER LED ON: Product powered by the external source LED OFF: Product not powered by the external source	Blue





# Interfaces in detail

## 6.1 Wi-Fi and Bluetooth

6.1.1 Wi-Fi specifications

## 6.2 Internal cellular modem

**(only for ABB Ability™ Edge Industrial Gateway with 3G connectivity)**

6.2.1 Internal cellular modem specifications  
(according to product versions)

6.2.2 LTE - single antenna operation notes

6.2.3 Main antenna requirements

6.2.4 Second antenna requirements (for antenna diversity)

6.2.5 The MicroSIM card holders

## 6.3 COM ports

6.3.1 Note for termination resistors for COM 1 in RS-485 mode

6.3.2 Note for fail-safe resistors for COM 0 in RS-485 mode

6.3.3 Note for fail-safe resistors for COM 1 in RS-485 mode

6.3.4 COM connector specifications

## 6.4 Ethernet ports

6.4.1 Ethernet specifications

6.4.2 ETH 0/1 connectors specifications

## 6.5 Host USB ports

6.5.1 USB 0/1 connectors specifications

6.5.2 USB 2 connector specifications

## 6.6 Expansion connector



# Interfaces in detail

## 6.1 Wi-Fi and Bluetooth

The ABB Ability™ Edge Industrial Gateway provides the following Wi-Fi / Bluetooth function:  
2.5 GHz Wi-Fi 802.11a,b,g,n / BLE 4.2 BLE Bluetooth 5 GHz Wi-Fi 802.11a,b,g,n

The internal circuitry allows for 2.5 GHz Wi-Fi and Bluetooth coexistence. The antennas connectors are placed on the front side.

### 6.1.1 Wi-Fi specifications

- Integrated 2.4 & 5G GHz Power Amplifier (PA) for WLAN solution.
- WLAN Baseband Processor and RF transceiver Supporting IEEE Std 802.11a/b/g/n.
- WLAN 2.4/5 GHz SISO (20/40 MHz channels).
- Baseband Processor.
  - IEEE Std 802.11a/b/g/n data rates and IEEE Std 802.11n data rates with 20 or 40 MHz SISO.
- Fully calibrated system. Production calibration not required.
- Medium Access Controller (MAC).
  - Embedded ARM™ Central Processing Unit (CPU).
  - Hardware-Based Encryption/Decryption using 64-, 128-, and 256-Bit WEP, TKIP or AES Keys.
  - Supports requirements for Wi-Fi Protected Access (WPA and WPA2.0) and IEEE Std. 802.11i (includes hardware-accelerated Advanced Encryption Standard (AES)).
  - Designed to work with IEEE Std 802.1x.
- IEEE Std 802.11d,e,h,i,k,r PICS compliant.
- New advanced co-existence scheme with BT/BLE.
- 2.4/5 GHz Radio.
  - Internal LNA and PA.
  - Supports: IEEE Std 802.11a, 802.11b, 802.11g and 802.11n.
- Supports 4 bit SDIO host interface, including high speed (HS) and V3 modes.

#### 2.4 GHZ TX output power

Maximum RMS output power measured at 1dB from IEEE spectral mask or EVM.

Parameter	Value
Operation frequency range	2412 to 2484 MHz
Output Power	17 dBm @ condition: 1 Mbps DSSS

#### 5 GHZ TX output power

Maximum RMS output power measured at 1dB from IEEE spectral mask or EVM.

Parameter	Value
Operation frequency range	4910 to 5825MHz
Output Power	16.8 dBm @ condition: 6 Mbps OFDM



## 6.2 Internal cellular modem (only for ABB Ability™ Edge Industrial Gateway with 3G connectivity)

The ABB Ability™ Edge Industrial Gateway supports the following Telit LE910 modem variants, according to product versions based on the geographic area of usage:

Version	Modem variant	Technology
ABB Ability™ Edge Industrial Gateway with 3G NA	Telit LE910-NA1 - North America	LTE Cat 1 3G Fallback
ABB Ability™ Edge Industrial Gateway with 3G EU	Telit LE910C1-EU - Europe	LTE Cat 1 3G Fallback

The antennas connectors are placed on the front side.

### 6.2.1 Internal cellular modem specifications (according to product versions)

#### Product features

- Rx Diversity and MIMO DL 2x2.
- LTE FDD Cat.1, 3GPP compliant.
- Built in UDP/TCP/FTP/SMTP stack.

#### LTE Data

- Uplink up to 5 Mbps.
- Downlink up to 10 Mbps.

#### Supported RF Bands

TELIT LE910 variant	Technology	4G bands	3G bands	2G bands
LE910-NA1 - North America	LTE Cat 1 (NA) 3G Fallback	B2, B4, B5, B12/ B13	B2, B5	-
LE910C1-EU - Europe	LTE Cat 1 3G Fallback	B1, B3, B7, B8, B20, B28A	B1, B3, B8	B3, B8

#### TX output power

Class 3 (0.2W, 23 dBm) @ LTE

### 6.2.2 LTE - single antenna operation notes

Single LTE antenna operation can be supported; however, typically, wireless carriers (Mobile Network Operators) impose restrictions. Please consult with your carrier before considering single LTE antenna usage. For optimum performance of the cellular interface, ABB recommends the use of both CELL MAIN and CELL DIV antenna connectors.

### 6.2.3 Main antenna requirements

#### Telit LE910C1-EU - Europe version

Feature	Value
Frequency range	Depending by the frequency band(s) provided by the network operator
Bands	See "Supported RF Bands" on the previous page
Impedance	50Ω
Input power	33 dBm(2 W) peak power in GSM 24 dBm average power in WCDMA & LTE
VSWR absolute max	≤ 10:1
VSWR recommended	≤ 2:1



### Telit LE910-NA1 - North America version

Feature	Value
Frequency range	Depending by the frequency band(s) provided by the network operator
Bands	See "Supported RF bands" on the previous page
Impedance	50Ω
Input power	> 24dBm Average power
VSWR absolute max	≤ 10:1
VSWR recommended	≤ 2:1

## 6.2.4 Second antenna requirements (for antenna diversity)

### Telit LE910-NA1 - North America version

Feature	Value
Frequency range	Depending by the frequency band(s) provided by the network operator
Impedance	50Ω
VSWR recommended	≤ 2:1

### Telit LE910C1-EU - Europe version

Feature	Value
Frequency range	Depending by the frequency band(s) provided by the network operator
Impedance	50Ω
VSWR recommended	≤ 2:1

## 6.2.5 The MicroSIM card holders

The ABB Ability™ Edge Industrial Gateway includes the following MicroSIM card holders:

- 1st MicroSIM card holder:
  - Integrated in a Combo MicroSD (push-pull) + MicroSIM (pull-lever) cards holder.
  - Placed on the top side of the circuit board in the Service Panel.
- 2nd MicroSIM card holder:
  - Push-pull card holder.
  - Placed on the bottom side of the circuit board in the Service Panel.

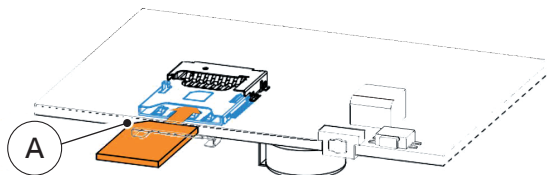
**Only the 1st MicroSIM card holder must be used for cellular connectivity.**

### How to insert / Remove the MicroSIM card

If you are using the holder on the top side of the circuit board To insert the MicroSIM card, complete the following steps:

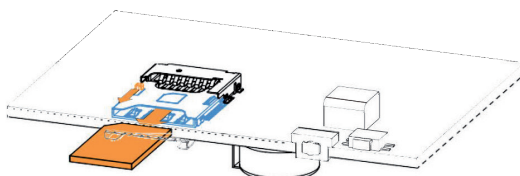
1. Orient the MicroSIM card with the contacts facing the circuit board and the cut corner - highlighted with the letter **A** - facing the holder.
2. Push the MicroSIM card in the holder.

Figure 8



To remove the MicroSIM card, pull the eject lever: use a pen tip to simplify the operation:

Figure 9





## 6.3 COM ports

The ABB Ability™ Edge Industrial Gateway provides the following COM ports:

- 1x RS-485: COM 0; Surge protected, Insulated, Half Duplex.
- 1x RS-232/485: COM 1; Surge protected, RS-485 termination and fail-safe resistors (Default: RS-232).

COM ports specifications:

- The COM ports are surge protected.
- Maximum supported baud rates are:
  - For RS-232 mode: up to 450 kbps.
  - For RS-485 mode: up to 1.75 Mbps.

The COM connectors are available on the front side.

### 6.3.1 Note for termination resistors for COM 1 in RS-485 mode

COM 1 has 2 pairs of pins (each signal is doubled):

- If the ABB Ability™ Edge Industrial Gateway is located at the beginning, or at the end, of a RS-485 chain, spare pair of pins can be used to connect permanently standard axial resistor 120Ω, if the application requires that.
- If the ABB Ability™ Edge Industrial Gateway is not at the beginning or at end of the RS-485 chain, two options are available:
  - Option 1: one pair of pins can remain not connected.
  - Option 2: one pair of pins can be used to connect the previous device of the chain, and the other pair can be used to connect the following device of the chain.

### 6.3.2 Note for fail-safe resistors for COM 0 in RS-485 mode

Fail-safe resistors (1.21 kΩ) are already inserted by default, and cannot be removed by the user.

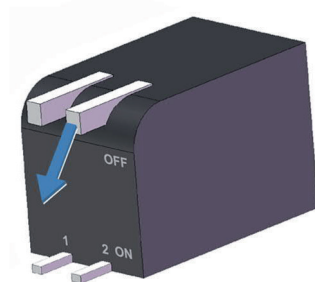
### 6.3.3 Note for fail-safe resistors for COM 1 in RS-485 mode

To insert the RS-485 fail-safe resistors, use the DIP switch available in the Service Panel.

#### Switches meaning

Default DIP switch configuration is OFF; this means no resistors inserted.

Figure 10



SW #	Signal	Description
1	RS232_RX/485_D+ Line	ON: 4.7 kΩ pull-up resistor inserted on COM 1
2	RS232_TX/485_D- Line	ON: 4.7 kΩ pull-down resistor inserted on COM 1



## 6.3.4 COM connector specifications

### Connector Layout:



### Connector Pinout:

Pin #	Signal	Type	Description
1	COM 0: D+	O	COM port 0: RS-485: A (D+ Line)
2	COM 0: D-	O	COM port 0: RS-485: B (D- Line)
3	COM 0: IGND	P	Ground (isolated)
4	COM 0: D+	I	COM port 0: RS-485: A (D+ Line)
5	COM 0: D-	I	COM port 0: RS-485: B (D- Line)
6	COM 1: TX/D-	O	COM port 1: RS-232: TX RS-485: B (D- Line)
7	COM 1: RX/D+	I	COM port 1: RS-232: RX RS-485: A (D+ Line)
8	COM 1: GND	P	Ground (not isolated)
9	COM 1: RX/D+	I	COM port 1: RS-232: RX RS-485: A (D+ Line)
10	COM 1: TX/D-	O	COM port 1: RS-232: TX RS-485: B (D- Line)

### Connector specifications:

- Base strip, Header.
- Gender: Male.
- Type: 10-pin, 3.5 mm pitch.

### Mating connector specifications:

- Pluggable screw terminal block.
- Gender: Female.
- Type: 10-pin, 3.5 mm pitch.
- Example:

Manufacturer: Shenzhen Connection Electronics Co., Ltd. Part Number: MC 1,5/10-STF-3,5 - 1847204 (or equivalent).



## 6.4 Ethernet ports

The ABB Ability™ Edge Industrial Gateway provides 2x 10/100 Mbps Ethernet ports:

- ETH 0.
- ETH 1 (Local LAN).

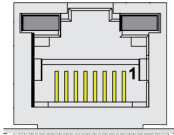
The Ethernet connectors are available on the rear side.

### 6.4.1 Ethernet specifications

Feature	Description
Network Standard	IEEE 802.3u 10/100-BaseTX. IEEE 802.3x full-duplex flow control.
Speeds	10/100-BaseTX interfaces with MAC
Notes	The interfaces are noise and surge protected. The RJ-45 connector has integrated magnetics.

### 6.4.2 ETH 0/1 connectors specifications

#### Connector layout:



#### Connector pinout (pins not listed are not connected):

Pin #	Signal	Type	Description
1	TX+	O	Transmit Data +
2	TX-	O	Transmit Data -
3	RX+	I	Receive Data +
6	RX-	I	Receive Data -

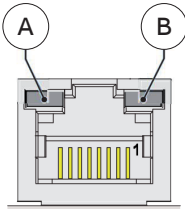
#### Connector specifications:

- RJ-45 socket.
- Gender: Female.

#### Mating connector specifications:

- RJ-45 plug.
- Gender: Male.

#### Connector LEDs layout:



#### LEDs meaning:

Ref #	LED color	LED meaning
A	Yellow	Activity
B	Green	Link



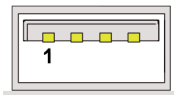
## 6.5 Host USB ports

The ABB Ability™ Edge Industrial Gateway provides 3x Host 2.0 USB ports (Noise and Surge Protected) for general purpose applications:

- USB 0 on the rear side; max load: 500 mA.
- USB 1 on the rear side; max load: 500 mA.
- USB 2 on the left side; max load: 1000 mA (ready to interface optional USB accessories).

### 6.5.1 USB 0/1 connectors specifications

#### Connector Layout:



#### Connector Pinout:

Pin #	Signal	Type	Description
1	V+	P	+5V
2	D-	IO	Negative data
3	D+	IO	Positive data
4	GND	P	Ground

#### Connector specifications:

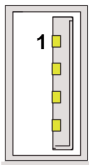
- USB Type-A socket.
- Gender: Female.

#### Mating connector specifications:

- USB Type-A plug.
- Gender: Male.

### 6.5.2 USB 2 connectors specifications

#### Connector Layout:



#### Connector pinout:

Pin #	Signal	Type	Description
1	V+	P	+5V
2	D-	IO	Negative data
3	D+	IO	Positive data
4	GND	P	Ground

#### Connector specifications:

- USB Type-A socket.
- Gender: Female.

#### Mating connector specifications:

- USB Type-A plug.
- Gender: Male.



---

## 6.6 Expansion connector

The ABB Ability™ Edge Industrial Gateway provides, on the right side, an expansion connector with the following interfaces:

- I/O additional Module.





---

# Mechanical specifications

**7.1 Product mechanical dimensions**

**7.2 Mounting bracket mechanical dimensions**

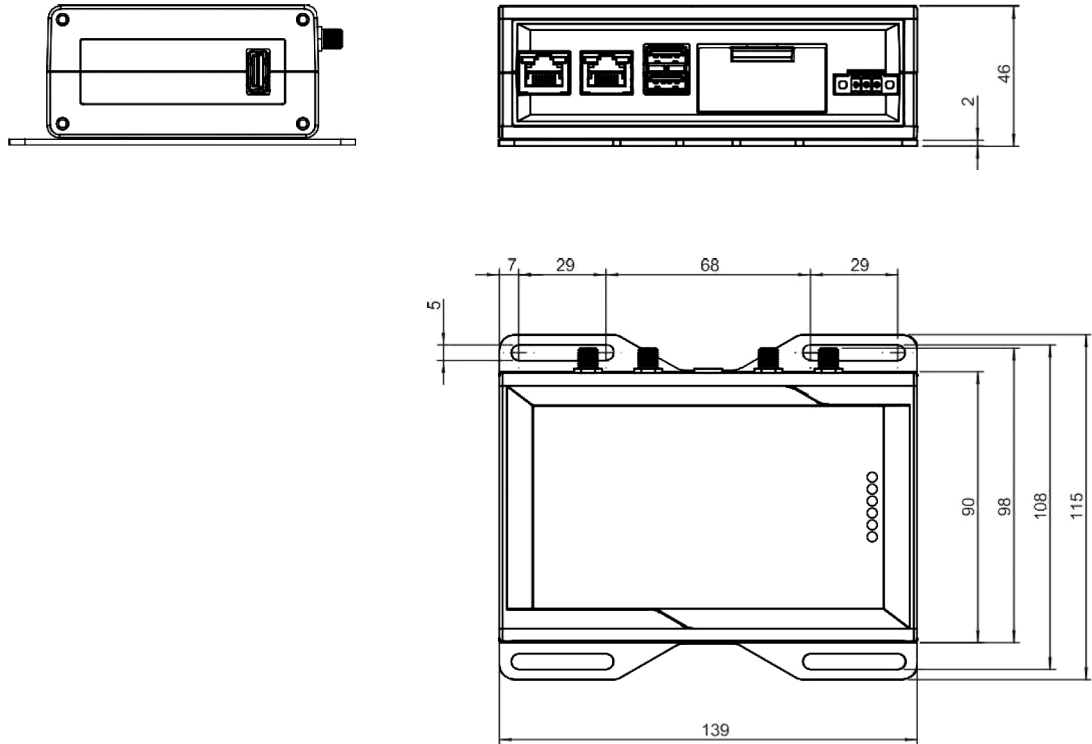


# Mechanical specifications

## 7.1 Product mechanical dimensions

The product electronics are housed in an ABS enclosure having the following dimensions: 139 (L) x 115 (W) x 46 (H); mm - Antennas Connectors and Mounting Bracket included. All dimensions are in millimeters.

Figure 11



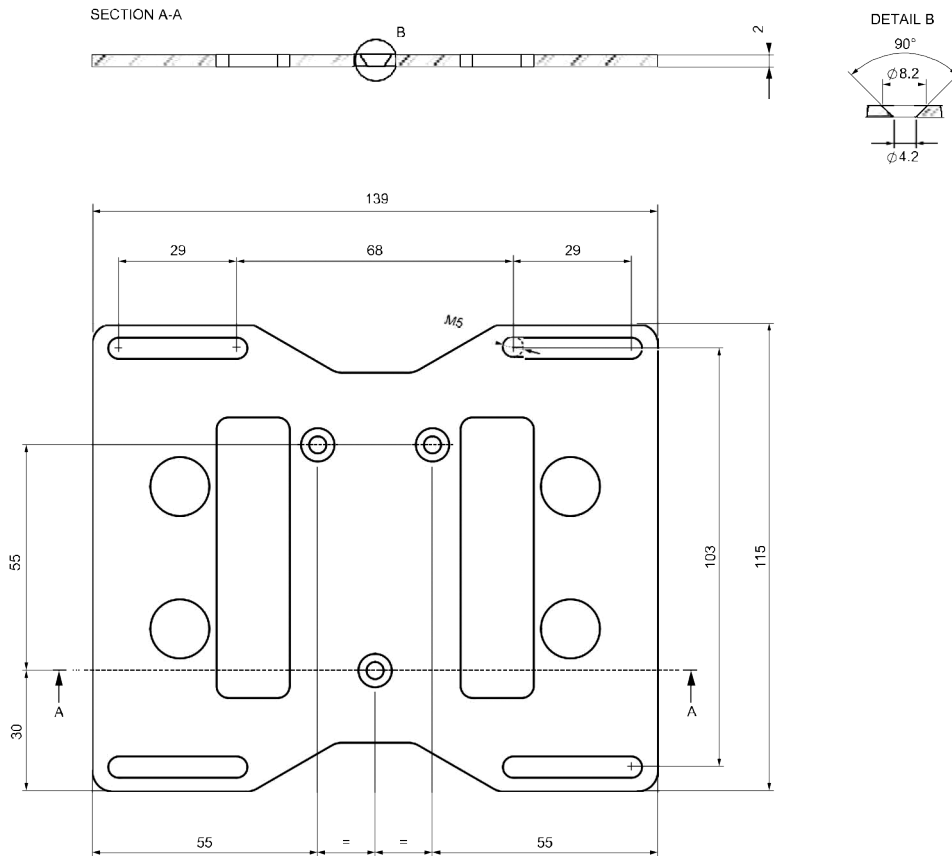


## 7.2 Mounting bracket mechanical dimensions

The Mounting Bracket fastened on the bottom side of the ABB Ability™ Edge Industrial Gateway has the following dimensions.

All dimensions are in millimeters.

Figure 12







---

# How to install the product

## **8.1 How to install the product using the mounting bracket**

## **8.2 How to replace the mounting bracket with the DIN rail mounting clip or vice versa**

8.2.1 How to replace the mounting bracket with the DIN rail mounting clip

8.2.2 How to replace the DIN rail mounting clip with the mounting bracket

8.2.3 Which screws are used with the mounting bracket or with the DIN rail mounting clip

## **8.3 How to install/remove the product on/from a DIN rail**

8.3.1 How to install the product on a DIN rail

8.3.2 How to remove the product from a DIN rail



# How to install the product

## 8.1 How to install the product

The product is intended for professional use and must be installed by qualified personnel only. The product must be installed in a secured location, accessible to authorized personnel only (for example in a cabinet / technical compartment).

By default, the ABB Ability™ Edge Industrial Gateway comes with a DIN rail mounting clip fastened on the bottom side. You can use this to install the ABB Ability™ Edge Industrial Gateway.

Optionally, you can replace the DIN Rail Mounting Clip with the Mounting bracket (optionally available). See also:

- “How to Install the Product Using the Mounting Bracket” below.
- “How to Replace the Mounting Bracket with the DIN Rail Mounting Clip or Vice Versa” on the next page.
- “How to Install/Remove the Product on/from a DIN Rail” on page 53.

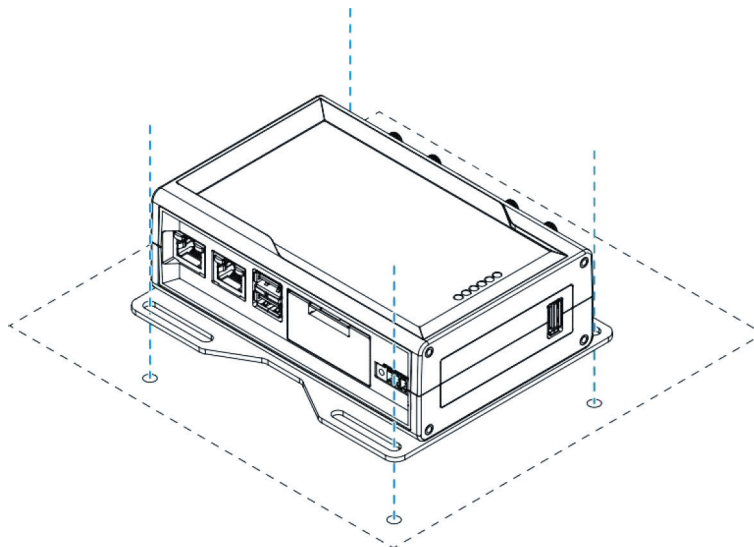
### 8.1.1 How to install the product using the mounting bracket

To install the product in place, complete the following steps:

1. See “Mechanical Specifications” on page 46.
2. Use the 4 slots available on the Mounting Bracket.
3. Add all the necessary mounting hardware to safely fasten the ABB Ability™ Edge Industrial Gateway in place according to your installation requirements (for example use 4xM5 screws, with a minimum length of 15mm). **Material, type, and length of the screws, and the maximum torque applicable, depend on your installation requirements.**

The Mounting Bracket is made of 2 mm aluminum alloy 6061 T6.

Figure 13





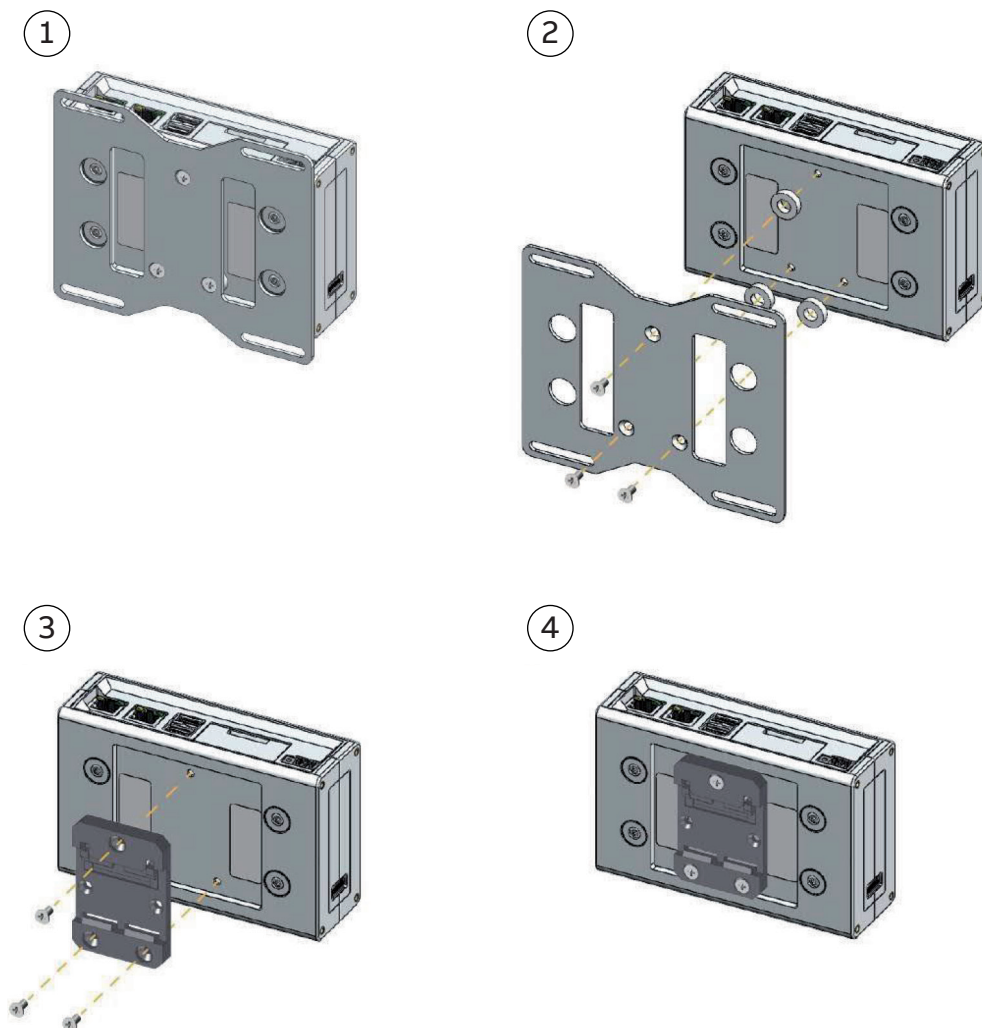
## 8.2 How to replace the mounting bracket with the DIN rail mounting clip or vice versa

### 8.2.1 How to replace the mounting bracket with the DIN rail mounting clip

To replace the Mounting Bracket with the DIN Rail Mounting Clip on the product, complete the following steps:

1. Remove the 3 screws that hold the Mounting Bracket in place.
2. Remove the Mounting Bracket and the 3 spacers (H = 4mm; Ext. diam. = 14mm; Int. diam. = 7mm).
3. Place the DIN Rail Mounting Clip.
4. Tighten the 3 screws removed at step 1 by applying a torque of 0.7 Nm.

Figure 14



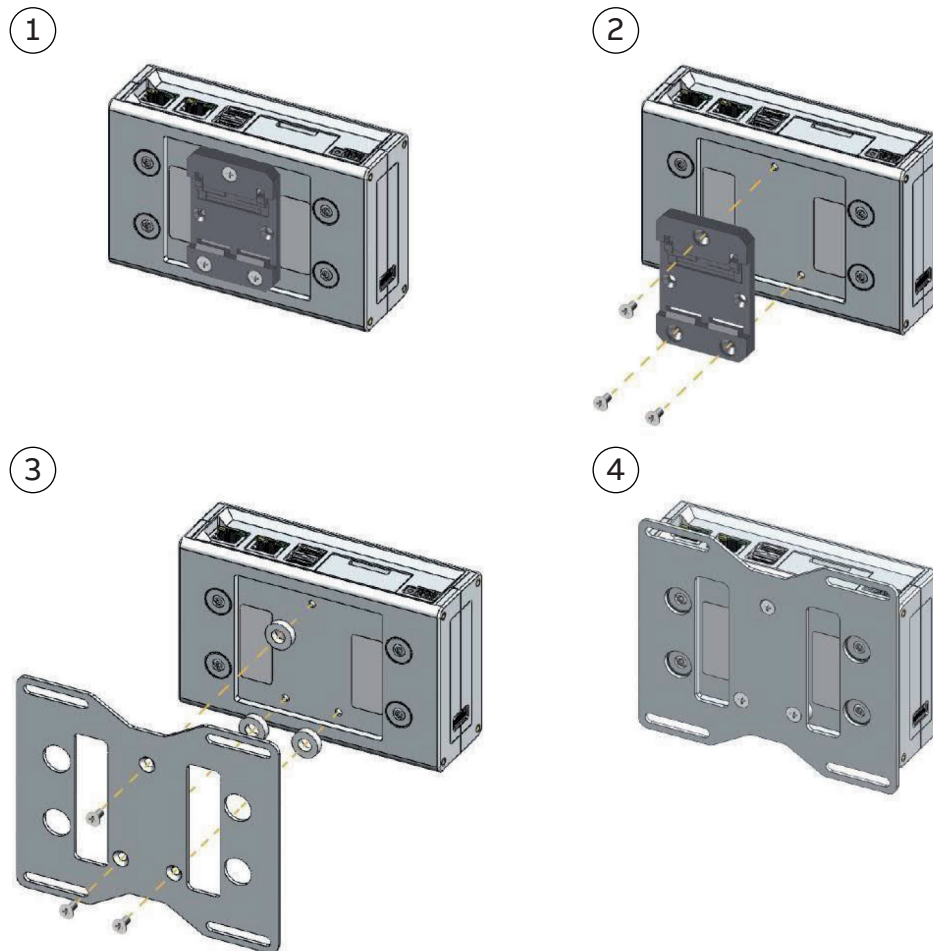


## 8.2.2 How to replace the DIN rail mounting clip with the mounting bracket

To replace the DIN Rail Mounting Clip with the Mounting Bracket on the product, complete the following steps:

1. Remove the 3 screws that hold the DIN Rail Mounting Clip in place.
2. Remove the DIN Rail Mounting Clip.
3. Place the 3 spacers (H = 4mm; Ext. diam. = 14mm; Int. diam. = 7mm) and the Mounting Bracket.
4. Tighten the 3 screws removed at step 1 by applying a torque of 0.7 Nm.

Figure 15

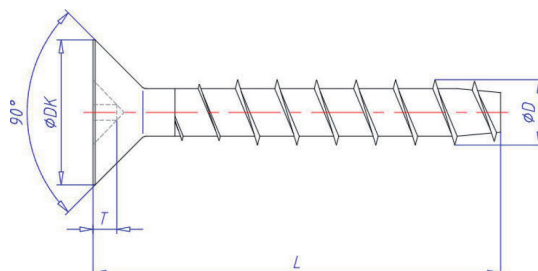


## 8.2.3 Which screws are used with the mounting bracket or with the DIN rail mounting clip

The 3 screws that hold in place the Mounting Bracket or the DIN Rail Mounting Clip have the following features:

- Phillips type H cross flat countersunk head screw KA35x12.
- Fully threaded.
- Stainless steel.
- Example of Manufacturer and Part Number: Bossard BN 13580 2000997.

Figure 16



Reference	Value (mm)
$\varnothing DK$	7.3
T	1.3
L	12
$\varnothing D$	3.5



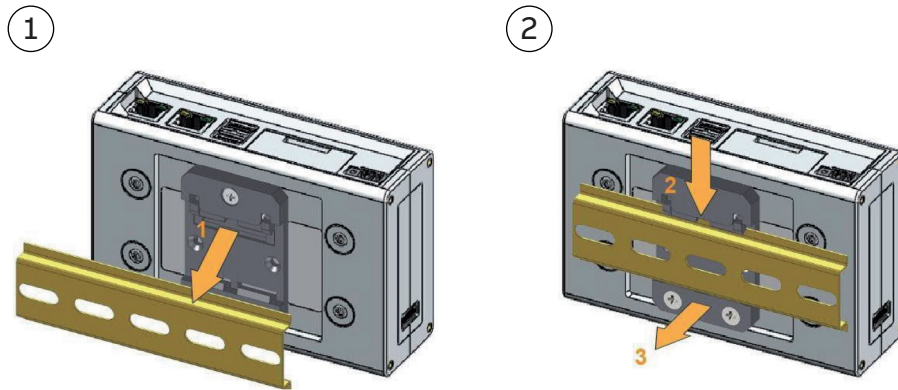
## 8.3 How to install/remove the product on/from a DIN rail

### 8.3.1 How to install the product on a DIN rail

Prerequisite: Replace the Mounting Bracket with the DIN Rail Mounting Clip To install the product on a horizontal DIN rail, complete the following steps:

1. Hook the upper mobile latches of the DIN Rail Mounting Clip on the upper edge of the DIN rail.
2. Push the product against the DIN rail. The lower latches of the DIN Rail Mounting Kit are locked on the DIN rail.

Figure 17

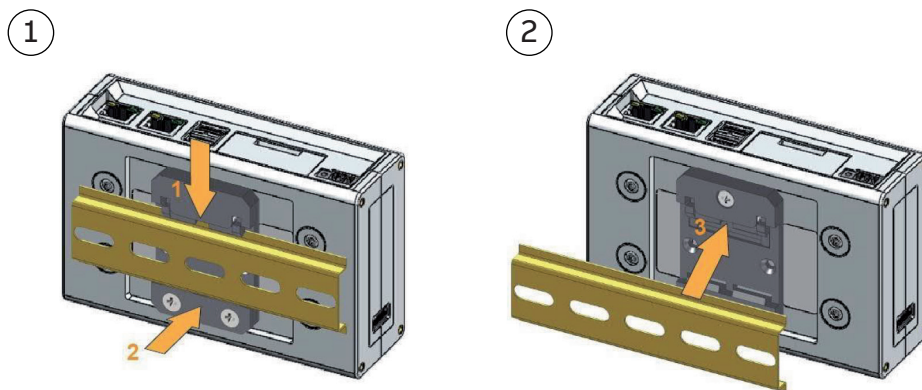


### 8.3.2 How to remove the product from a DIN rail

To remove the product from a horizontal DIN rail, complete the following steps:

1. Push downwards the upper mobile latches of the DIN Rail Mounting Clip. The lower latches are released from the DIN rail.
2. Pull the product out.

Figure 18







---

# How to supply power to the product

## 9.1 How to supply power to the product

9.1.1 Power IN connector and mating connector specifications

## 9.2 How to supply power and turn ON the product

## 9.3 How to trigger a hardware reset of the product



# How to supply power to the product

This product is not provided with any ON/OFF switch.  
The Power IN connector is the disconnecting means from the power supply network.

## 9.1 How to supply power to the product

Power supply	Nominal: 12 or 24 VDC; Range: 9 to 30 VDC with transient protection
Power consumption	4 W typical; 15 W maximum
Peak demand	< 15 W

### 9.1.1 Power IN connector and mating connector specifications

The power input is protected against: surge, noise, reverse polarity, over-voltage.

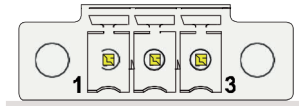


#### NOTICE

The Power IN connector is NOT protected against short circuit. Always include an external fuse to protect the product!

The ABB Ability™ Edge Industrial Gateway provides the Power IN connector on the rear side.

#### Connector layout:



#### Connector Pinout:

Pin #	Signal	Type	Description
1	V+	P	+5V
2	D-	IO	Negative data
3	D+	IO	Positive data
4	GND	P	Ground

#### Connector specifications:

- Base strip, Header.
- Gender: Male.
- Type: 3-pin, 3.5 mm pitch.

#### Mating connector specifications:

- Pluggable screw terminal block.
- Gender: Female.
- Type: 3-pin, 3.5 mm pitch.
- Example:
  - Manufacturer: Phoenix Contact.
  - Part Number: MC 1,5/ 3-STF-3,5 - 1847068 (or equivalent).



## 9.2 How to supply power and turn ON the product



**WARNING!**  
ELECTRIC SHOCK HAZARD

Failure to supply power correctly or to follow all operating instructions correctly, may create an electric shock hazard, which could result in personal injury or loss of life, and / or damage the equipment or other property.

To avoid injuries and safely supply power to the product, complete the following steps:

1. Observe all the instructions for safety, installation, and operation.
2. Make sure your hands are dry.
3. Make sure that all the cables used:
  - Are in good condition before using them.
  - Meet the product requirements and comply with the relevant standards and regulations.
4. Position cables with care. Do not position cables in places where they may be trampled or compressed by objects placed on them.
5. Make sure that the power-points and plugs are in good condition before using them.
6. Do not overload the power-points and plugs.
7. Make sure that the product maintains a proper grounding connection.
8. Use a power supply that meets the product requirements and complies with the relevant standards and regulations. In case of uncertainties, contact the ABB Technical Support Team (for more information see “How to Receive Technical Assistance”).
9. Connect power after the installation of the system has been completed.
10. Never connect or disconnect the cables with the system or the external apparatus switched ON.

To supply power and turn ON the ABB Ability™ Edge Industrial Gateway, complete the following steps:

1. Setup a DC power source that:
  - Meets the ABB Ability™ Edge Industrial Gateway power requirements.
  - Deliver a maximum current of 2 A.
2. Check the input voltage as close as possible to the Power IN connector. This is to compensate for any cable losses, caused by cable length and other cable characteristics.
3. Make sure that the DC power source is turned OFF.
4. Setup an external 2 A fuse on the line coming from the negative terminal of the DC power source.
5. Connect the DC power source terminals (“Power IN +” and “Power IN -”) to Pins 1 and 2 of the Power IN connector:

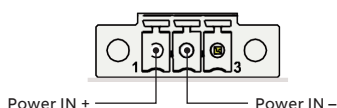


Figure 19

## 9.3 How to trigger a hardware reset of the product

To trigger a hardware reset of the ABB Ability™ Edge Industrial Gateway, push the reset pushbutton available in the Service Panel.

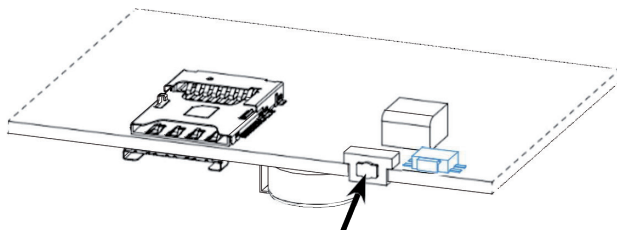


Figure 20





---

# How to maintain the product

**10.1 How to safely remove the power supply**

**10.2 How to verify the installation  
of the product**

**10.3 How to clean the product**



---

# How to maintain the product

Periodically inspect the product to verify its integrity and to ensure proper operation. To maintain the product, complete the following steps:

1. Carefully read and understand the instructions contained in the section “Safety Instructions” on page 8.
2. Safely remove the power supply.
3. Verify the installation of the product.
4. Clean the product.

---

## 10.1 How to safely remove the power supply



**WARNING!**  
ELECTRIC SHOCK HAZARD

Failure to remove power correctly may create an electric shock hazard, which could result in personal injury or loss of life, and / or damage the equipment or other property.

To avoid injuries and safely remove power supply from the product, complete the following steps:

1. Make sure your hands are dry.
2. Turn OFF all the power supply sources.
3. Disconnect all the cables.
4. Make sure that all the circuits are discharged.

---

## 10.2 How to verify the installation of the product

To verify the installation of the product, complete the following steps:

1. Verify that the product is clean and not damaged.
2. Verify that the LED indicators are visible and not damaged.
3. Verify that all the locking parts (for example: screws, bolts, nuts) are correctly fastened.
4. Verify that the product is installed correctly.

---

## 10.3 How to clean the product

To clean the product, complete the following steps:

1. Never use detergents, aerosol sprays, solvents or abrasive sponges.
2. To remove dust from the case of the product, use a dry, lint-free, cloth.
3. To remove the dirt, use water-based, non-flammable, cleaner products.







# Cyber Security Deployment Guideline

## **11.1 Secure system setup**

11.1.1 Basic system hardening rules

## **11.2 Access control**

11.2.1 Web server access

11.2.2 User accounts

11.2.3 SSH (Secure Shell) Access - only for developer & maintenance role

11.2.4 Adding Gateway hostname in client machine (Windows)

11.2.5 Accessing web server (Local view)

## **11.3 Ports and services**

11.3.1 Ports

11.3.2 Device firewall

## **11.4 Time service**

## **11.5 Security event monitoring**

11.5.1 Web server security events (only for Edge Gateway)

11.5.2 Daemon server security events

11.5.3 System security events

## **11.6 Firmware update**

## **11.7 Disclaimer**



# Cyber Security Deployment Guideline

## 11.1 Secure system setup

### 11.1.1 Basic system hardening rules

Today's distribution automation systems are basically specialized IT systems. Therefore, several rules of hardening an automation system apply to these systems, too. Protection and control relays are from the automation system perspective on the lowest level and closest to the actual primary process. It is important to apply defense-in-depth information assurance concept where each layer in the system is capable of protecting the automation system and therefore protection and control relays are also part of this concept.

The following should be taken into consideration when planning the system protection.

- Recognizing and familiarizing all parts of the system and the system's communication links.
- Removing all unnecessary communication links in the system.
- Rating the security level of remaining connections and improving with applicable methods.
- Hardening the system by removing or deactivating all unused processes, communication ports and services.
- Checking that the whole system has backups available from all applicable parts.
- Collecting and storing backups of the system components and keeping those up-to-date.
- Removing all unnecessary user accounts.
- Defining password policies.
- Changing default passwords and using strong passwords.
- Checking that the link from substation to upper level system uses strong encryption and authentication.
- Segregating public network (untrusted) from automation networks (trusted).
- Segmenting traffic and networks.
- Using firewalls and demilitarized zones.
- Assessing the system periodically.
- Using malware protection in workstations and keeping those up-to-date.

It is important to utilize the defence-in-depth concept when designing automation system security. It is not recommended to connect a device directly to the Internet without adequate additional security components. The different layers and interfaces in the system should use security controls. Robust security means, besides product features, enabling and using the available features and also enforcing their use by company policies. Adequate training is also needed for the personnel accessing and using the system.



---

## 11.2 Access Control

This section describes system hardening measures that can be taken to limit access to various components in ABB Ability™ Edge Industrial Gateway only for users with predefined permissions/access rights.

### 11.2.1 Web server access

By default, Edge Gateway Web Server will have only below User ID and password from FACTORY:

User ID: OWNER@abb.com

Password: 12345678

During the first-time login with above credentials to Web Server, user is prompted to change the password.

#### **Password policy**

For new password to be set by user, below are the defined password complexity rule which must be met. A password must have:

- ✓ Password must be at least 8-characters in length.
- ✓ Password must contain at least one uppercase letter.
- ✓ Password must contain at least one lowercase letter.
- ✓ Password must contain at least one special character.
- ✓ Password must contain at least one numeric character.
- ✓ Password must not exceed maximum 15-characters in length.

#### **Account lockout policy**

In Web Server, if a user failed to authenticate 5-times with incorrect password, his account will be locked. The locked period time is 15-minute and after elapsing this period, User is again allowed to login into web server (with correct password only).

#### **Password history**

In Web Server, user password history is maintained and user can not set the last 3-passwords again. If user enters the same password, he is prompted to choose another password.

#### **Password RESET**

In Web Server, OWNER (admin) can reset user password. A new random password is created for the user whose password is reset and when same user login to Web Server with system created password, user is prompted to change password.

If OWNER (admin) forgets/lost his/her password, the user can reset the password via Provision Tool.

#### **Password validity**

In Web Server, the validity of password is defined for 180-Days, and after expiry of this time, user is prompted to change his/her password.

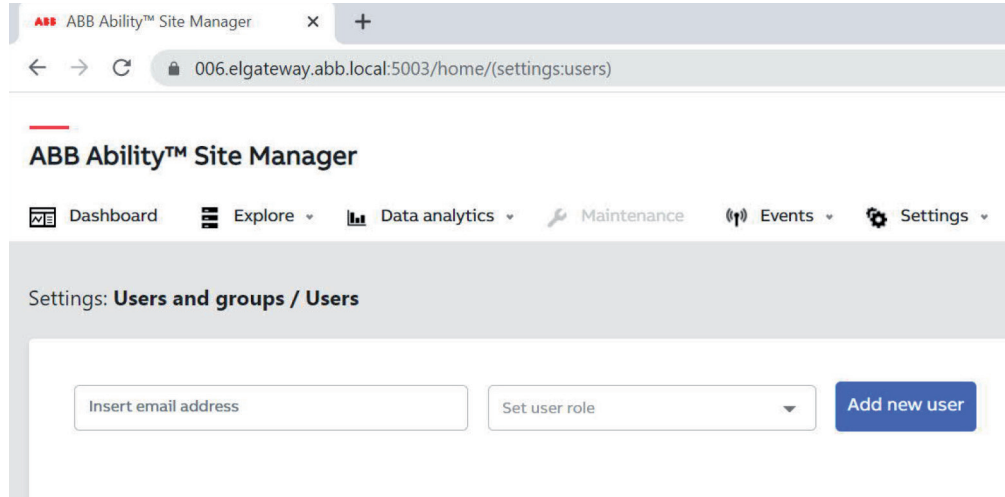


## 11.2.2 User accounts

### Edge Gateway web server user account

Owner user in the Edge Gateway Web Server can add users with email ID as user unique ID and a random password is generated for new user with meeting password complexity rule. When new user login with the allotted user ID and default password, he is prompted to change his password during 1st time login to web server.

Figure 21  
Users and groups / Users



Additionally, Edge Gateway web server support Role Based Access Control (RBAC).

Figure 22  
RBAC in Edge Gateway

CRUD - Create Read Update Delete CRU - Create Read Update RU - Read Update R - Read	Owner	Manager	Energy responsible	Maintenance responsible	Staff	Guset
		as owner, except for EULA	as staff + some settings for energy	as staff + some settings for asset		only dashboard
EULA resp. (sign EULA9)	RU	R	R	R	R	-
Site groups	CRUD	CRUD	R	R	R	-
Site Settings: energy billing, cost plan	CRUD	CRUD	CRUD	R	R	-
Site Settings: User mgmt + assign roles	CRUD	RUD	-	-	-	-
Asset (flat list) view (from commissioning), navigation	R	R	R	R	R	-

### 11.2.3 SSH (Secure Shell) Access - only for developer & maintenance role

In ABB Ability™ Edge Industrial Gateway, SSH (Secure Shell) is NOT available for customer and is disabled. This is available only to internal ABB Developers & Maintenance Role users for debugging purpose.

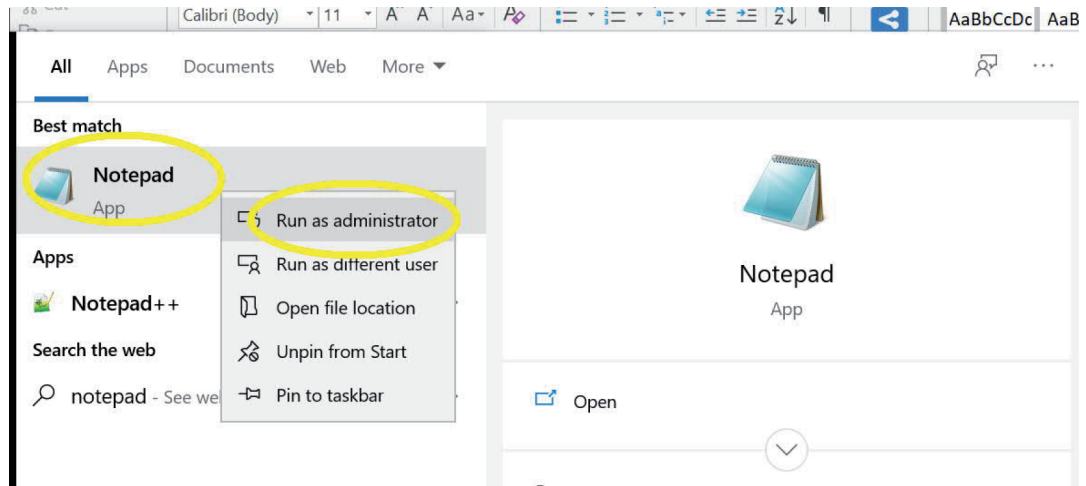


## 11.2.4 Adding Gateway hostname in client machine (Windows)

For the device name to be used with communications (example: <https://xxx.elgateway.abb.local:5003>) user computer needs to have host defined in hosts file. This can be added with Administrative rights, open the Notepad application:

Note: this is optional, device can be accessed by using IP address

Figure 23

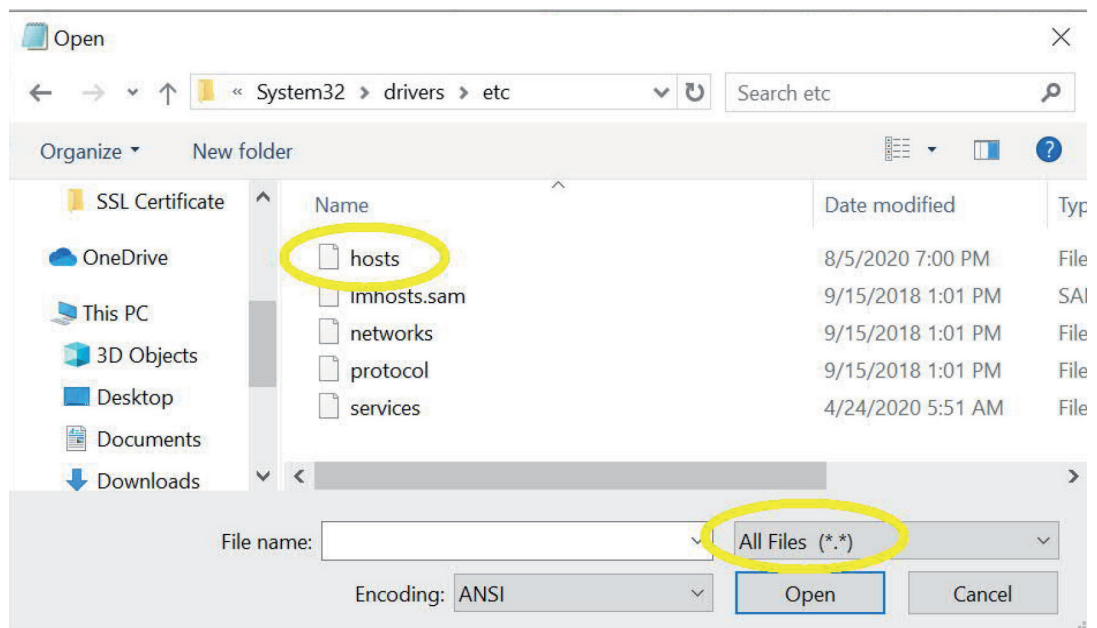


Navigate to below path

**C:\Windows\System32\drivers\etc**

Set “All Files (\*.\*)” option and select “hosts” file and click “Open”:

Figure 24





In the “hosts” file, add the below line as per “IP address” & “hostname” of the Gateway:

Figure 25

```

# Copyright (c) 1993-2009 Microsoft Corp.
#
# This is a sample HOSTS file used by Microsoft TCP/IP for Windows.
#
# This file contains the mappings of IP addresses to host names. Each
# entry should be kept on an individual line. The IP address should
# be placed in the first column followed by the corresponding host name.
# The IP address and the host name should be separated by at least one
# space.
#
# Additionally, comments (such as these) may be inserted on individual
# lines or following the machine name denoted by a '#' symbol.
#
# For example:
#
#       102.54.94.97       rhino.acme.com           # source server
#       38.25.63.10      x.acme.com             # x client host
#
# localhost name resolution is handled within DNS itself.
# 127.0.0.1       localhost
# ::1            localhost
192.168.2.1 xxx.elgateway.abb.local

```

Where “xxx” is the digits 4 to 7 (for example A490050.....000 → 0050) of the Gateway Serial number.

### 11.2.5 Accessing web server (Local view)

To access the web server, user can use default IP address: <https://192.168.2.1:5003>.

Web server is only available in Local view version.

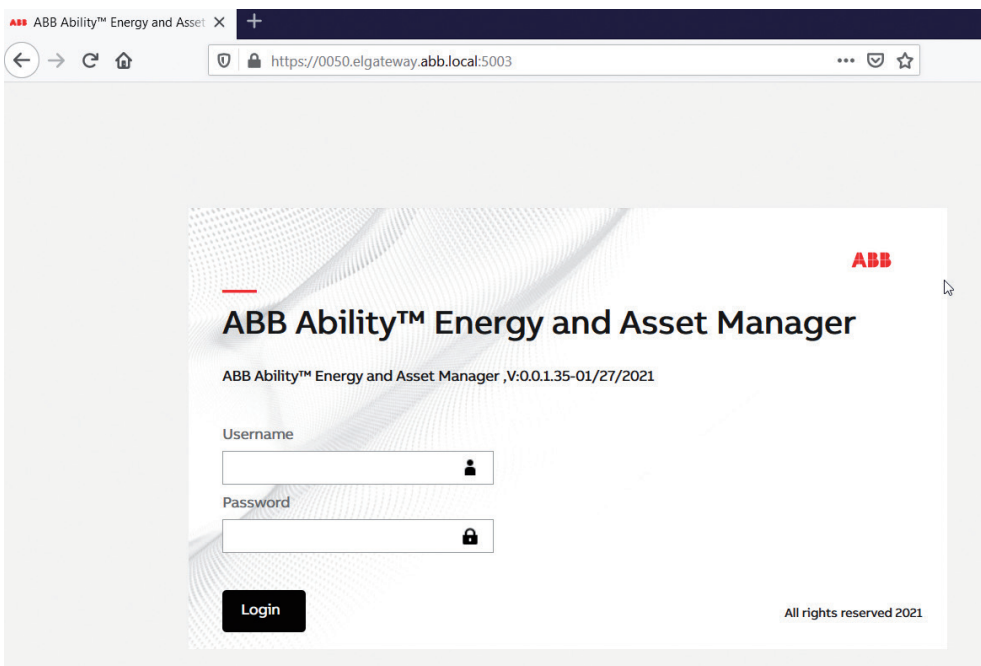
To access the web server, user need to replace “xxx” below with the digits 4 to 7 (for example A490050.....000 → 0050) of the ABB Gateway Serial number:

<https://xxx.elgateway.abb.local:5003>

For example:

<https://006.elgateway.abb.local:5003>

Figure 26





Below is Roles-to-rights Mapping information for Edge Gateway web server users:

CRUD - Create Read Update Delete CRU - Create Read Update RU - Read Update R - Read	Applicable to Edge	Owner	Manager	Energy responsible	Maintenance responsible	Staff	Guset
			as owner, except for EULA	as staff + some settings for energy	as staff + some settings for asset		only dashboard
EULA resp. (sign EULA9)	yes	RU	R	R	R	R	–
Site groups	yes	CRUD	CRUD	R	R	R	–
Site Settings: energy billing, cost plan	yes	CRUD	CRUD	CRUD	R	R	–
Site Settings: User mgmt + assign roles	yes	CRUD	RUD	–	–	–	–
Site user logs (activities on UI)	yes	R	R	–	–	–	–
Asset (flat list) view (from commissioning), navigation	yes	R	R	R	R	R	–

## 11.3 Ports and services

The ABB Ability™ Edge Industrial Gateway provides 2x 10/100 Mbps Ethernet ports:

- ETH 0.
- ETH 1.

The Internet Protocol (IP) communications in ABB Ability™ Edge Industrial Gateway rely on two parameters: IP Address and Ports. An Ethernet port (Local LAN) in ABB Ability™ Edge Industrial Gateway represents a physical end point to the network (LAN/WAN), to which it is connected. Typically during commissioning, a network administrator assigns an IP address to each of the ETHs associated with ABB Ability™ Edge Industrial Gateway.

By default, the LOCAL ETH1 is assigned an IP address of 192.168.2.1. During commissioning we recommend changing these IP addresses.

### 11.3.1 Ports

Ports are used in IP communications along with IP address. Ports represent a logical end point through which data flows from a source to the destination machine. Ports are identified by numbers ranging from 0 to 65535.

Software processes within ABB Ability™ Edge Industrial Gateway communicate on the network through a combination of IP Address, Port and a communication protocol. A communication protocol, such as HTTP, Modbus TCP, signifies a set of rules to be used when sending/receiving data over the network.

The table below list the ports used by various software processes in ABB Ability™ Edge Industrial Gateway accomplishing a specific functionality.

Application Type	Application Name	Interface	Port Number	Default state	Connection Type
Web Server (Local view)	HTTPS	ETH1	5003	Open/Inbound	TCP
Daemon Server (Provision Tool)	HTTPS	ETH1	5001	Open/Inbound	TCP
DHCP (Dynamic IP)	DHCP	ETH0/WiFi/Cellular	67	Open/Inbound	UDP
DHCP (Dynamic IP)	DHCP	ETH0/WiFi/Cellular	68	Open/Inbound	UDP
Time Sync	NTP	ETH0/WiFi/Cellular	123	Closed/Outbound	UDP
DNS (Name resolution)	DNS	ETH0/WiFi/Cellular	53	Closed/Outbound	TCP
Modbus TCP (Device configuration)	Modbus TCP	ETH1	502	Open/Inbound	TCP
Modbus TCP (Field devices communication)	Modbus TCP	ETH1	502	Closed/Outbound	TCP
FOTA	HTTPS	ETH0	443	Closed/Outbound	TCP

Please note that WiFi & Cellular is available only for certain models.



### 11.3.2 Device firewall

Network security in ABB Ability™ Edge Industrial Gateway is accomplished by defining a set of rules used by device. Internal firewall is a software application which allows or blocks any software program executing within ABB Ability™ Edge Industrial Gateway from establishing a connection on the network.

The network connection can be an outgoing connection initiated from ABB Ability™ Edge Industrial Gateway or an incoming connection to ABB Ability™ Edge Industrial Gateway. The outgoing connection rules are defined by creating outbound rules and the incoming connection rules are defined by creating inbound rules.

The rules specify whether to allow or block a connection based on some defined criteria.

The table below shows a brief summary of the rules available:

Rule name	Rule description
HTTPS	Allows TCP connection on port 5001 & 5003. This rule allows incoming secure HTTPS traffic for ABB Ability™ Edge Industrial Gateway.
MODBUS-TCP	Allows TCP connection on port 502. This rule allows incoming Modbus messages which are further handled by Modbus Slave in ABB Ability™ Edge Industrial Gateway.
NTP	Allows UPD connection on port 123. This rule allows incoming NTP messages which are further handle by NTP client in ABB Ability™ Edge Industrial Gateway.
Reject ALL incoming SSH	Rejects all TCP connection on port 22. This rule rejects all incoming TCP traffic for SSH for ABB Ability™ Edge Industrial Gateway.
Allow outbound DNS	Allows UDP connection on port 53. This rule allows incoming DNS requests for name resolution.

The port 5003 can be firewalled using Provision Tool. User can add Local view (web server) to be available in eth0 and limit incoming connections by source IP address (Configuration → Gateway Connectivity → To Web Server)

## 11.4 Time service

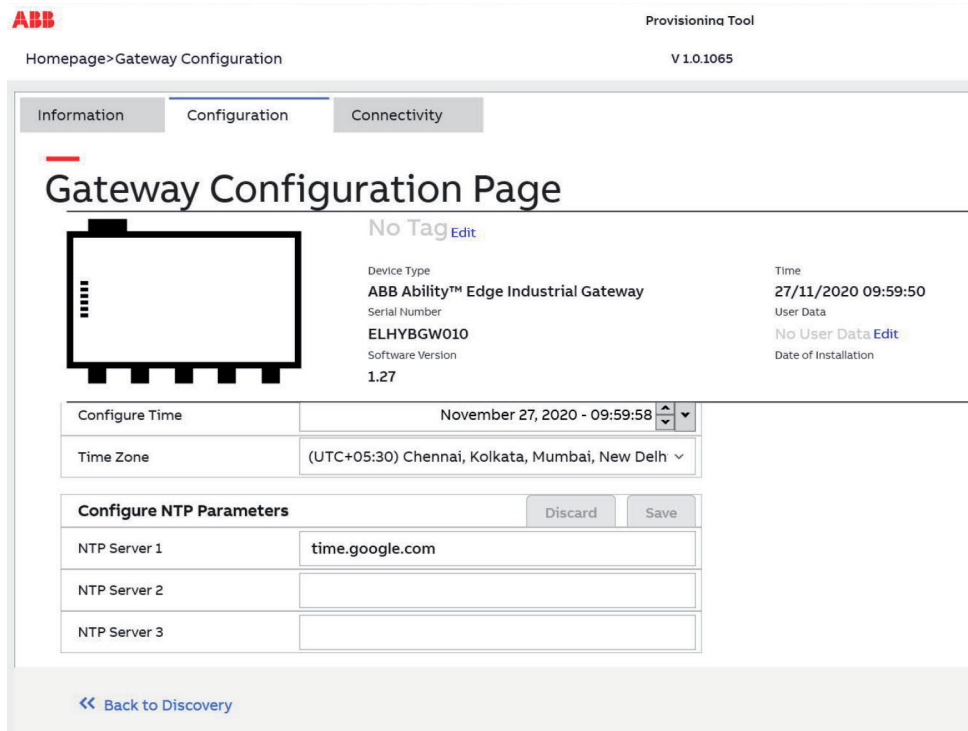
Time used in ABB Ability™ Edge Industrial Gateway can be synchronized using NTP client to an NTP Server like Google NTP Server.

User can configure maximum three NTP Servers using Provisioning Tool. By default, one of the NTP time servers is shipped along with the ABB Ability™ Edge Industrial Gateway (with time.google.com).

User can configured all the three NTP Servers using CCT tool.

Figure 27

Note: It is recommended to set the NTP synchronization to local network stratum 1 clock



Time Synchronization is performed at every Powerup of ABB Ability™ Edge Industrial Gateway & there after everyone hour.

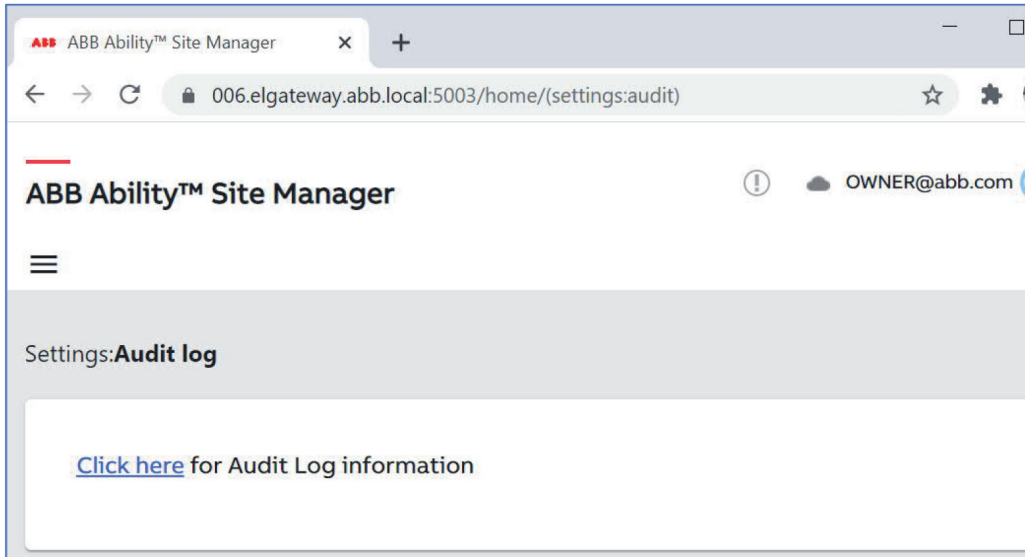


## 11.5 Security event monitoring

Audit policies provide a means to monitor various actions by a user or a software process in ABB Ability™ Edge Industrial Gateway. The events generated by a specific audit policy denote a success or failed result for some action.

For Edge Gateway, Owner & Managers can download the event monitoring audit log files by navigating in Web Server to **Settings** → **Audit log**

Figure 28



### 11.5.1 Web server security events (only for Edge Gateway)

Audit policies provide a means to monitor various actions by a user or a software process in ABB Ability™ Edge Industrial Gateway. The events generated by a specific audit policy denote a success or failed result for some action.

For Web Server audit log events, below are the events which is logged:

Sr. No.	Event Type	Event Component	Event Log Description
1	ADD Billing	Billing	Log for adding Billing details
2	UPDATE Billing	Billing	Log for updating Billing details
3	UPDATE device settings	Devices	Log for updating device settings
4	Deactivate device	Devices	Log for deactivate device
5	Add Group	Group	Log for adding new group
6	Update Group	Group	Log for updating group
7	Delete Group	Group	Log for deleting group
8	User Login	Authentication	Log for login to web server by user
9	User Login	Authentication	Log for login unsuccessful by user
	User Log Out	Authentication	Log for logout event for a user
10	Reset Password	Owner Reset Password	Log for Owner's password reset using Provisioning Tool
11	ID Change	Owner ID Change	Log for Owership transfer
12	SAVING Site Information	Site Details	Log for saving site information
13	Updating site information	Site Details	Log for site information update
14	ADD User	Profiles	Log for creating new user in web server
15	RESET User Password	Profiles	Log for passowrd reset for a user
16	UPDATE User Password	Profiles	Log for password update for a user in web server
17	CHANGE User Role	Profiles	Log for role change of a user in web server
18	DELETE User	Profiles	Log for delete of a user in Web server
19	LOCKED User	Profiles	Log for user locked after unsuccessful login attempts

The log format is as defined below and the file is saved in .csv format:

Date	Time	Session/Token	UserID	EventType	Success/Failed	EventComponent	ClientAddress
------	------	---------------	--------	-----------	----------------	----------------	---------------



## 11.5.2 Daemon server security events

For Daemon Server audit log events, below is the apis logged by device:

Sr. No.	Event	Detail
1	Configuration change	Store device id to edge.env file.
2	Configuration change	Store device type to edge.env file.
3	Configuration change	Store PKI enrollment password to dpcm.config file.
4	Register Gateway	Start Device register process
5	Fw download File	Download file (gateway firmware, device firmware, daemon).
6	Fw apply Update	Update gateway firmware.
7	Fw delete Downloads	Delete all Downloaded files (gateway firmware, device firmware, daemon).
8	IP Address config	Update gateway IP address.
9	Serial Ports update	Updates localsettings.json with the new configuration.
10	wifi - enable	Enable Wifi.
11	wifi - disable	Disable Wifi.
12	wifi - setup	Set Wifi SSID and Password
13	NTP Config	Add Sntp Configs.
14	NTP Time sync	Run Sntp.
15	Set time	set time in Gateway
16	Set timezone	set timezone in Gateway
17	Update cellular settings	Set cellular config and start service.
18	Cellular enable	Set cellular service enable.
19	ssh enable	Enable SSH Server.
20	ssh disable	Disable SSH Server.

## 11.5.3 System security events

For system audit log events, below are the events which will be logged:

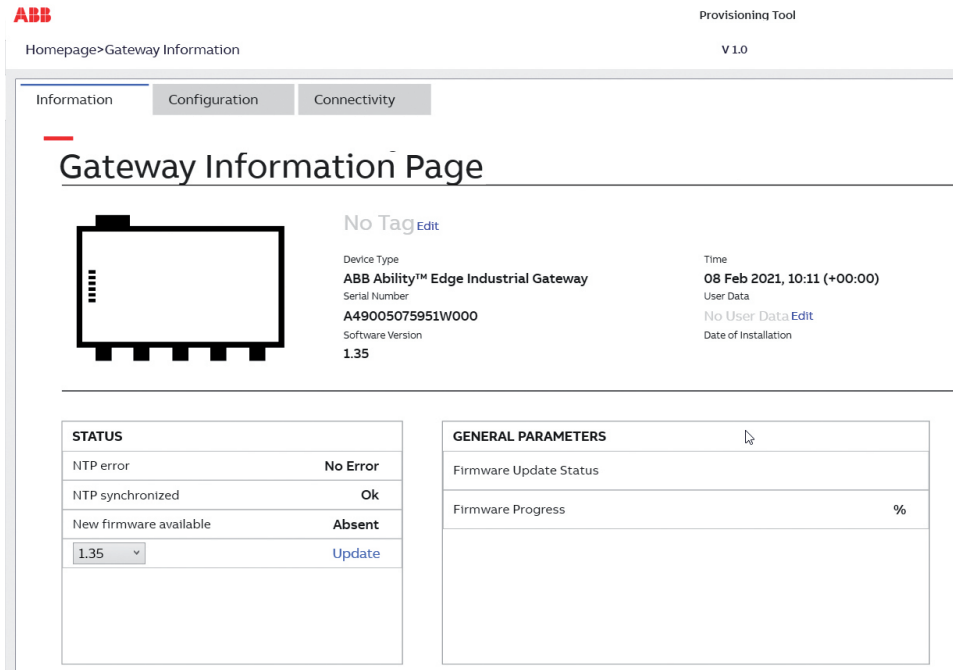
Sr. No.	Event	Key Value
1	kernel module loading and unloading	auditd_modules
2	logon and logout events	auditd_logins
3	time change through stime, settimeofday, localtime file, clock_settime, adjtimex	auditd_time_rules
4	system's discretionary access controls	auditd_perm_mod
5	file deletion events by user	auditd_delete
6	use of privileged commands	auditd_privileged
7	unauthorized access attempts to files	auditd_access
8	system administrator actions	auditd_actions
9	modify the system's network environment	auditd_rules_networkconfig_modification
10	alter process and session initiation information	auditd_session
11	modify user/group information	auditd_rules_usergroup_modification
12	information on exporting to media	auditd_export
13	modify the system's mandatory access controls	auditd_MAC-policy

## 11.6 Firmware update

The device firmware upgrade will be applied to the Gateway via Provisioning Tool. With this tool, user can start firmware download and update process. The update process can be initiated by gateway owner user via Provisioning Tool, as shown in Figure 29 (next page):

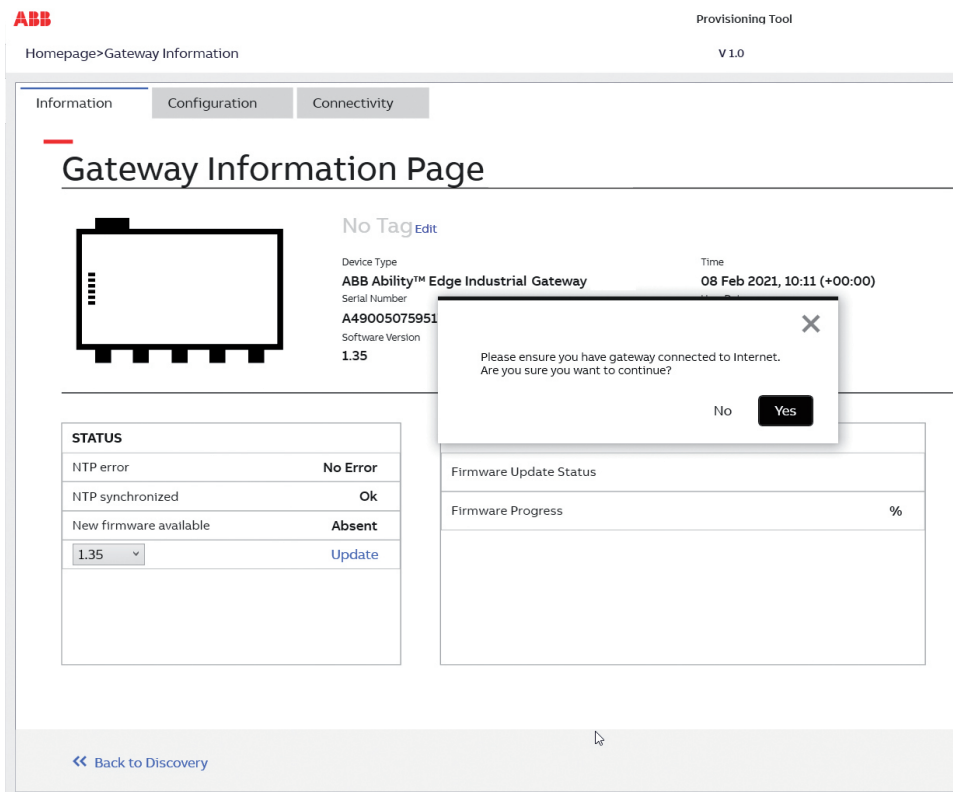


Figure 29



To initiate firmware update process via CCT, user need to provide working internet connection to gateway’s ETH0 port. Once internet connection is available to gateway, user need to wait till LED1 goes GREEN in the Gateway. Once, LED1 is GREEN, user can press “update” button as shown above in Figure 31 to start the firmware update process in Gateway. A dialogue window will pop-up to confirm to continue the process. Once user press “Yes” button, firmware update process is initiated in the Gateway.

Figure 30



The firmware update process in Gateway is initiated with Provisioning Tool sending the relevant information to the Gateway to download the firmware file from ABB hosted cloud. With this download process in initiated and once it is completed, Gateway will apply the update & reboot gateway.



---

## 11.7 Disclaimer

The data, examples and diagrams in this manual are included solely for the concept or product description and are not to be deemed as a statement of guaranteed properties.

All persons responsible for applying the equipment addressed in this manual must satisfy themselves that each intended application is suitable and acceptable, including that any applicable safety or other operational requirements are complied with. In particular, any risks in applications where a system failure and/or product failure would create a risk for harm to property or persons (including but not limited to personal injuries or death) shall be the sole responsibility of the person or entity applying the equipment, and those so responsible are hereby requested to ensure that all measures are taken to exclude or mitigate such risks.

This product has been designed to be connected and communicate data and information via a network interface which should be connected to a secure network. It is the sole responsibility of the person or entity responsible for network administration to ensure a secure connection to the network and to take the necessary measures (such as, but not limited to, installation of firewalls, application of authentication measures, encryption of data, installation of anti virus programs, etc.) to protect the product and the network, its system and interface included, against any kind of security breaches, unauthorized access, interference, intrusion, leakage and/or theft of data or information. ABB is not liable for any such damages and/or losses.

This document has been carefully checked by ABB but deviations cannot be completely ruled out. In case any errors are detected, the reader is kindly requested to notify the manufacturer. Other than under explicit contractual commitments, in no event shall ABB be responsible or liable for any loss or damage resulting from the use of this manual or the application of the equipment. In case of discrepancies between the English and any other language version, the wording of the English version shall prevail.







---

# Annex 1: additional I/O module

**12.1 Product labels**

**12.2 Configuration**

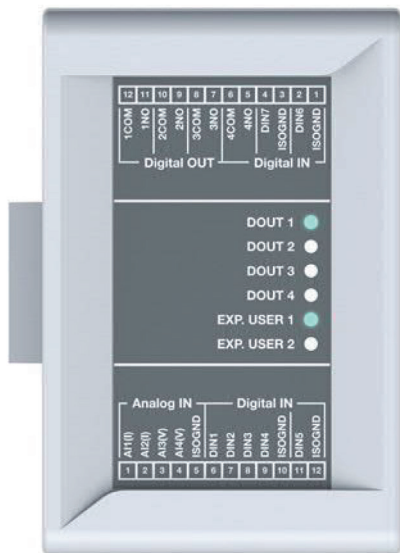


# Annex 1: additional I/O module

The I/O module is a compact and lightweight device intended to be used together with your ABB Ability™ Edge Industrial Gateway gateway.

I/O module is a fast and simple way to expand the capabilities of ABB Ability™ Edge Industrial Gateway with extra digital and analog ports. Designed to be fitted to the side of the ABB Ability™ Edge Industrial Gateway, it is rated for the same level of reliability and operating temperature range. The digital section of I/O module provides 6x isolated digital inputs and 4x isolated digital outputs, while the analog section provides 2x protected current analog inputs and 2x protected voltage analog inputs.

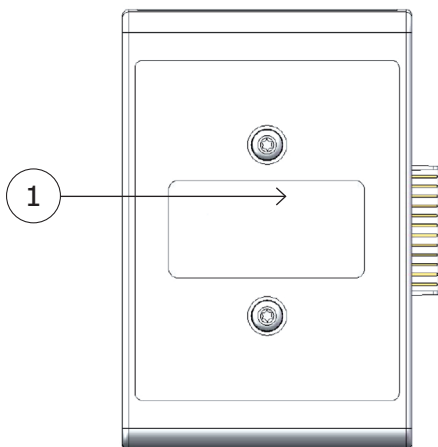
Figure 31



## 12.1 Product labels

The product label is located on the bottom side of the product.

Figure 32





<ul style="list-style-type: none"> <li>• ABB &amp; Eurotech logo</li> <li>• Manufacturer address</li> <li>• Manufacturer</li> <li>• product name</li> <li>• product model</li> <li>• I/O module serial number</li> <li>• FCC logo</li> <li>• CE mark</li> <li>• WEEE symbol</li> </ul>	<p><b>ABB</b> I/O Module <b>EUROTECH</b>  <b>Manufacturer:</b> Eurotech Ltd, 2 Clifton Court, Cambridge, CB1 7BN, UK  <b>Product:</b> ReliaIO 10-12  <b>Model:</b> REIO-10-12-02-CS01  <b>Made in Taiwan</b>  <b>Serial Number:</b>          7060-56569-001-101-YY-XXXXX</p>
--	--

## 12.2 Configuration

The additional IO module can be configured using Provision Tool. Please refer to: **ABB Ability™ Energy and Asset Manager Cloud Provisioning Guide**

Provisioning Tool

Homepage > Gateway Connectivity > Internet V 1.0

Information
Configuration
Connectivity
Modules

### Gateway I/O Modules Page

**0002** [Edit](#)

Device Type  
 ABB Ability™ Edge Industrial Gateway

Serial Number  
 A49000275951W000

Software Version  
 1.33

Time  
 15 Jan 2021, 11:19 (+01:00)

User Data  
 fota 1.33 [Edit](#)

Date of Installation  
 12 Jan 2021, 08:56 (+01:00)

Analog
Digital

#### Analog Inputs

Current		Voltage	
AIN1	AIN2	AIN3	AIN4
Sensor not set in this position	Sensor not set in this position	Sensor not set in this position	Sensor not set in this position
<a href="#">Add Sensor</a>	<a href="#">Add Sensor</a>	<a href="#">Add Sensor</a>	<a href="#">Add Sensor</a>





---

# Declaration of conformity

## 13.1 CE Marking

## 13.2 WEEE compliance

## 13.3 RoHS 2 compliance

## 13.4 Electromagnetic compatibility

13.4.1 Electromagnetic compatibility (for EU)



# Declaration of conformity

## 13.1 CE Marking

This product is CE marked.

The product meets the guidelines listed in the following sections.

ABB is not responsible for the use of this product together with equipment (eg power supplies, personal computers, etc) that are not CE marked and compliant with the requirements specified in this document.

This product is compliant with:

- Reduction of Certain Hazardous Substances (RoHS2).
- IP40.
- CE.
- IEC62368-1 Information Technology Equipment - Safety - Part 1: General Requirements.
- Product compliance with part 15 of FCC.

## 13.2 WEEE compliance

In compliance with the Directive 2012/19/EU of the European Parliament and of the Council of 4 July 2012 on waste electrical and electronic equipment (WEEE), the symbol above, shown on the product or within its literature, indicates separate collection for this electrical and electronic equipment (EEE) that has been placed on the market after 2005.

This product, at the end of its life cycle, must be collected separately and managed in accordance with the provisions of the current Directive on waste electrical and electronic equipment.

Because of the substances present in the product, improper use or disposal of the refuse can cause damage to human health and the environment.

For any possible legal implications, contact your local waste collection body for full recycling information.

## 13.3 RoHS 2 compliance

The product described in this document, including all its components and its sub- assemblies, have been manufactured in compliance with the Directive 2011/65/EU of the European Parliament and of the Council of 8 June 2011 on the restriction of the use of certain hazardous substances in electrical and electronic equipment.



## 13.4 Electromagnetic Compatibility

### 13.4.1 Electromagnetic compatibility (for EU)

#### Conditions of operation

This product meets the requirements of the EC Directive 2004/108/EC on electromagnetic compatibility.

This product is designed for use in industrial areas.

#### FCC compliance (for USA)

This device and its accessories comply with part 15 of FCC rules. Operation is subject to the following two conditions:

- This device and its accessories may not cause harmful interference.
- This device and its accessories must accept any interference received, including interference that may cause undesired operation.

Specifications		Description
Processor	MCU	STM 32F072xx – 32 bit ARM Cortex M0
Memory	RAM	16KB SRAM with hardware parity
Storage	Embedded	128KB Flash
	Digital Input	6x Digital Input Ports Input Range 0-36V Optoisolation 5kV (2.7kV RMS) Low Level Voltage: 0-1V High Level Voltage: 2-36V 0/1 Level Threshold: 1V/2V (Factory Option: Customizable)
	Digital Output	4x Digital Output Ports Optoisolation 5kV(2.7kV RMS) Open Drain Output Transistors: 60V (Optorelay) AC/ DC Output: 0.5A MOSFET (with 0.5A Fuses)
I/O interfaces	Analog Input	2x Current Analog Input Ports Input Range: 4-20mA 2x Voltage Analog Input Ports Input Range: 0-36V ADC Conversion: 12 bit Sigma Delta Sampling Frequency: 1kHz Max Input Protection Circuitry (5kV DC)
Other	LEDs	4x Digital Output Status 2x
	Input	Provided by ABB Ability™ Edge Industrial Gateway
Power	Consumption	0.3W Typical
	Operating Temp	-25 °C to +85 °C
Environment	Storage Temp	-40 °C to +85 °C
	Regulatory	FCC/ISED, CE
	Safety	EN 60950 (Including UL Deviations to EN62368-1)
	Environmental	RoHS2; REACH
Certifications	Ingress	IP40 (enclosure only, excluding connectors)
	Enclosure	Material: ABS - Colour: aluminium
Mechanical	Dimensions	90.3 x 59 x 43.7 mm (WxLxH)





---

# Mechanical specifications

## How to install the product

### 14.1 I/O module mechanical dimensions

### 14.2 How to install the product

14.2.1 How to attach I/O module to ABB Ability™ Edge Industrial Gateway



# Mechanical specifications

## How to install the product

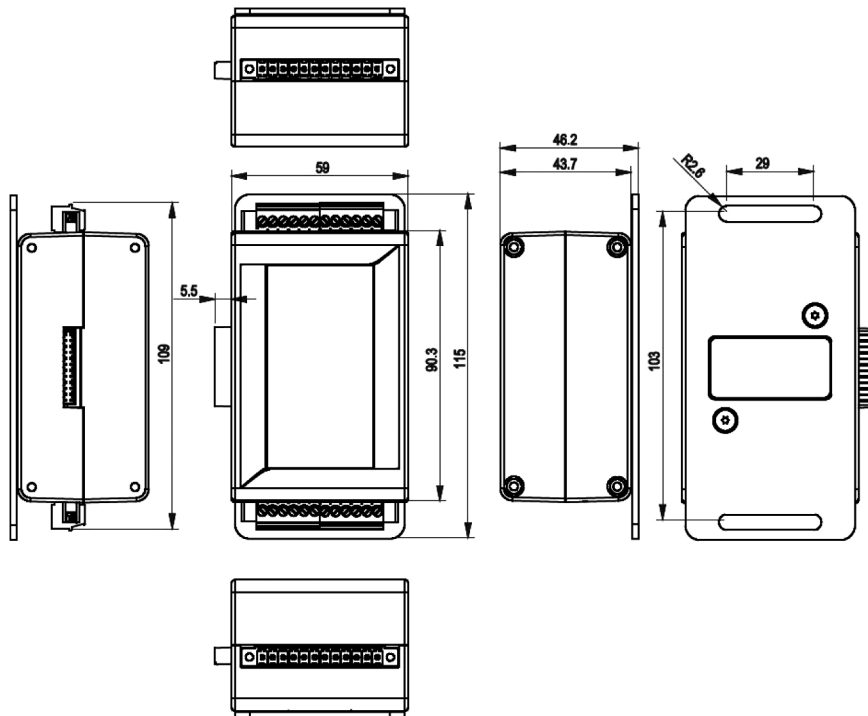
### 14.1 I/O module mechanical dimensions

The I/O modules are housed in an ABS enclosure having the following dimensions:  
90.3 (W) x 59.0 (L) x 43.7 (H); mm

The I/O module enclosure is supplied on a mounting plate having the dimensions shown in the drawing (Figure 33) below:

All dimensions are in millimetres.

Figure 33



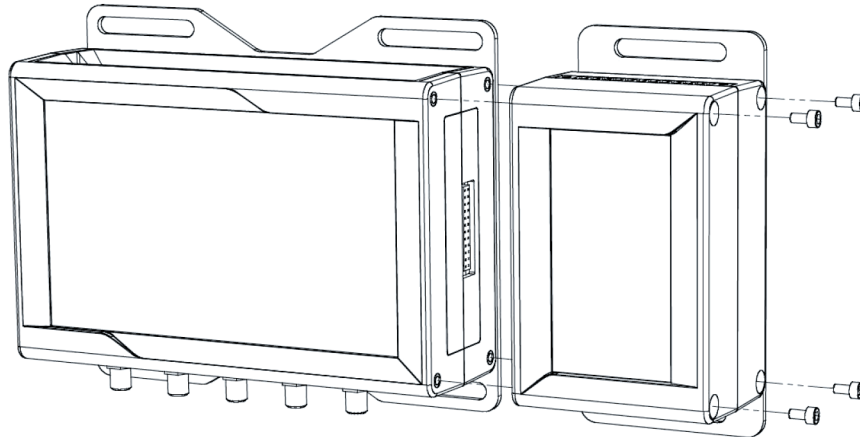


## 14.2 How to install the product

### 14.2.1 How to attach I/O module to ABB Ability™ Edge Industrial Gateway

- Attach the I/O additional module 10-12-xx unit to the ABB Ability™ Edge Industrial Gateway as shown below using M2.5 x 5 CAP Head screw.
- Screw the I/O additional module mounting plate to the same flat surface as the ABB Ability™ Edge Industrial Gateway.

Figure 34

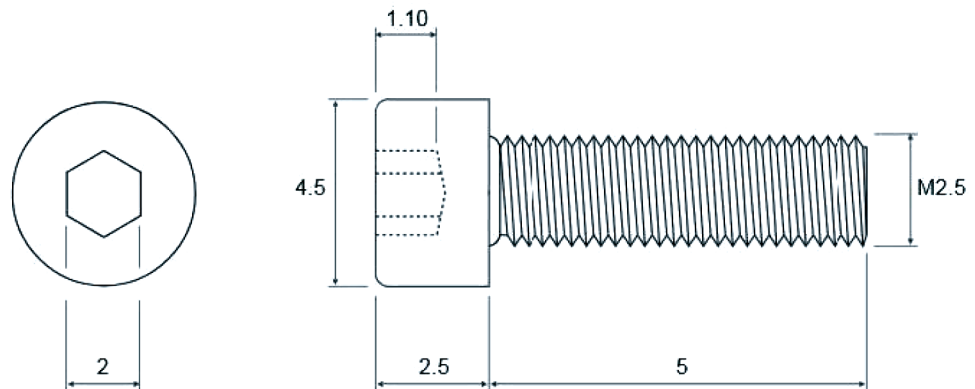


#### Which screws are used

The 4 screws are used to attach I/O module to ABB Ability™ Edge Industrial Gateway:

- M2.5 x 5 CAP Head Hexagon Socket.
- Black A4 Stainless steel, fully threaded.

Figure 35







---

# Basic configuration via provisioning tool

**15.1 Connect**

**15.2 Configuration**

**15.3 Connectivity (Ethernet settings)**



# Basic configuration via provisioning tool

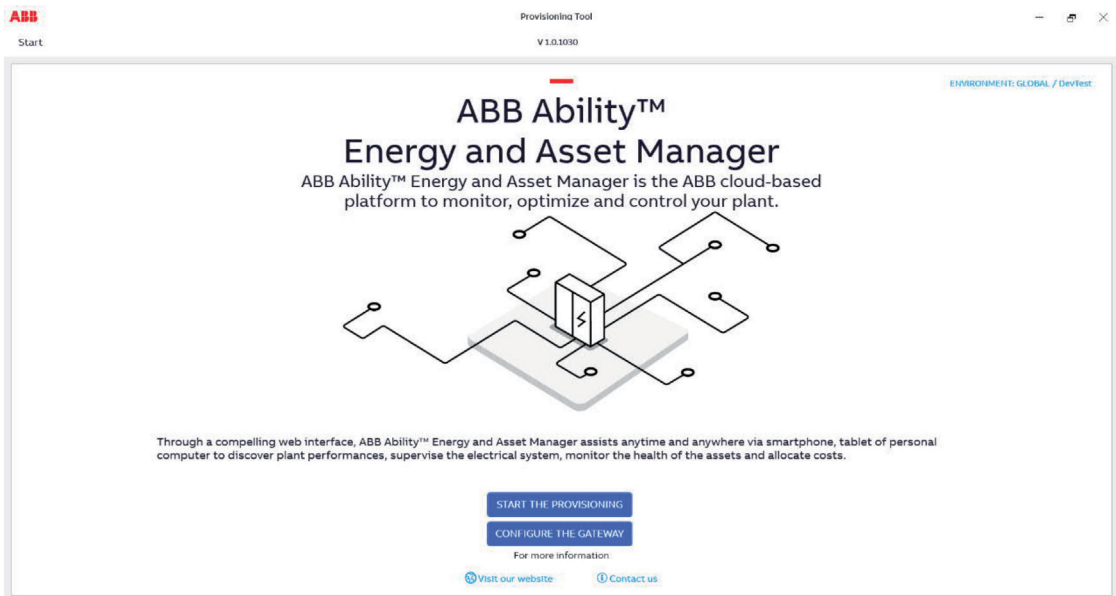
## 15.1 Connect



### Warnings

Do not incorrectly configure the software, as this can lead to inaccurate data results. Be sure that your laptop is connected directly to ETH1 of the EL Edge Gateway.

The ABB Ability™ Edge Industrial Gateway is configured using windows based ABB Provisioning Tool. After installation of the tool and after the login the user will find a gateway configuration button called "Configure the gateway". the user needs to connect to the gateway ETH0 port to configure it.



After clicking on "Configure the gateway" the automatic/manual discovery page appears

## Discover ABB Gateways

Discover modules connected to local network. Select "Automatic discovery" or "Manual discovery", then click on "Start Discovery".

- Automatic discovery**  
Automatically find ABB gateway modules connected to the local network.
- Manual discovery**  
Define search criteria to find ABB gateway modules connected to the local network.

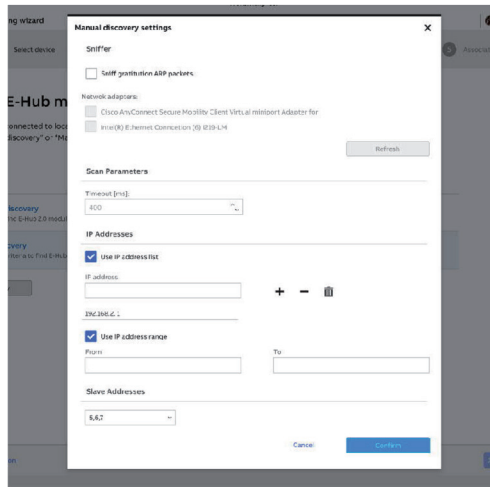
[Start over](#)

✔ Gateway found



After clicking "Start Discovery":

- If automatic discovery is selected, the auto-scan process starts with visual feedback of the status (like on gateway discovery for provisioning).
- If manual discovery is selected, a dialog with the network scanning options pops up .



## 15.2 Configuration

After discover, device can be selected and configuration page is opened


The configuration page contains the following elements:

- Time parameters (manual).
- NTP parameters (automatic clock synchronization).
- Maintenance Access.
- Owner Details.
  - change owner or reset password.



Information
Configuration
Connectivity
Modules

## Gateway Configuration Page



**0002** [Edit](#)

Device Type <b>ABB Ability™ Edge Industrial Gateway</b>	Time 15 Jan 2021, 11:19 (+01:00)
Serial Number <b>A49000275951W000</b>	User Data fota 1.33 <a href="#">Edit</a>
Software Version 1.33	Date of Installation 12 Jan 2021, 08:56 (+01:00)

---

**Configure Time Parameters** [Discard](#) [Save](#)

Configure Time Jan 15, 2021 - 11:19:47

Time Zone (UTC+01:00) Amsterdam, Berlin, Bern, Rome, Stoc

**Configure NTP Parameters** [Discard](#) [Save](#)

NTP Server 1 time.google.com

NTP Server 2 0.pool.ntp.org

NTP Server 3 1.pool.ntp.org

**Maintenance Access**

Maintenance Access Enable

**Owner Details**

Transfer Owner  [Apply](#)

Reset Password [Reset](#)

## 15.3 Connectivity (Ethernet settings)

The connectivity page has configuration

- internet setting (eth0).
  - connection needed for firmware update.
- Device settings (eth1).
  - devices connected to gateway (local LAN).
- Site Manager.
  - settings for where Site Manager (5003) can be accessed.
  - firewall settings for port.



- Information
- Configuration
- Connectivity
- Modules

## Gateway Connectivity Page



0002 [Edit](#)

Device Type  
**ABB Ability™ Edge Industrial Gateway**  
Serial Number  
**A49000275951W000**  
Software Version  
**1.33**

Time  
**15 Jan 2021, 11:19 (+01:00)**  
User Data  
**fota 1.33 [Edit](#)**  
Date of Installation  
**12 Jan 2021, 08:56 (+01:00)**

- To The Internet
- To Devices
- To Webserver

<b>eth0</b>	<input type="button" value="Discard"/>	<input type="button" value="Save"/>
IP Address		
Subnet Mask		
Gateway	0.0.0.0	
Force Static IP Address	<input checked="" type="checkbox"/>	
Static IP Address	. . .	
Static Network Submask	. . .	
Static Gateway	. . .	
DNS Server1	0 . 0 . 0 . 0	
DNS Server2	0 . 0 . 0 . 0	
MacAddress	ac:d3:64:00:2f:4a	





---

# Annex 2: Web server Configuration (Local view)

**16.1 Configuration of the connections  
to web server**

**16.2 Navigation to web server**



# Annex 2: Web server Configuration (Local view)

## 16.1 Configuration of the connections to web server

The FACTORY shipped device will have below configuration steps

A. Edge Gateway Web server is accessible on ETH1 5003 Port of the gateway.

B. Connect Ethernet cable from gateway’s ETH1 port to PC/Laptop ETHERNET port.

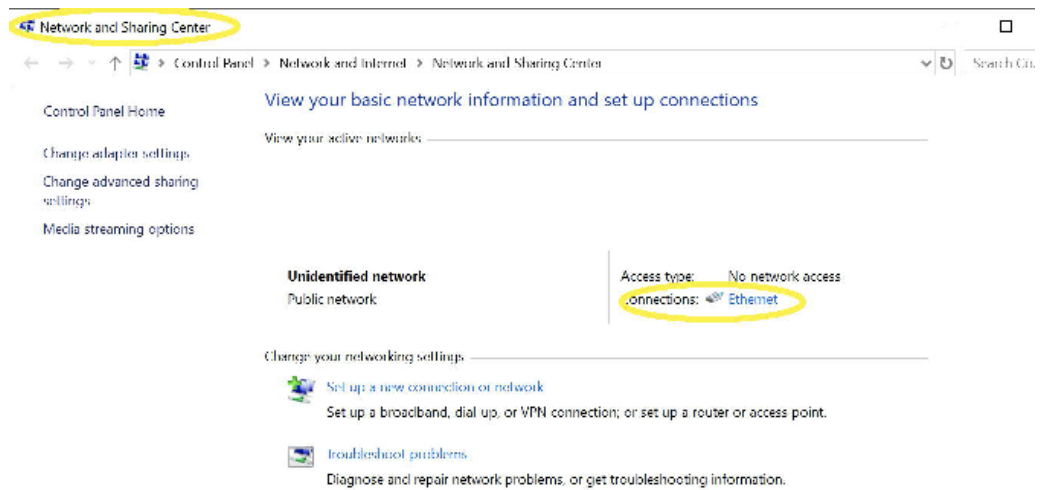
C. Edge Gateway default ETH1 IP address & subnet mask is:

IP Address: 192.168.2.1

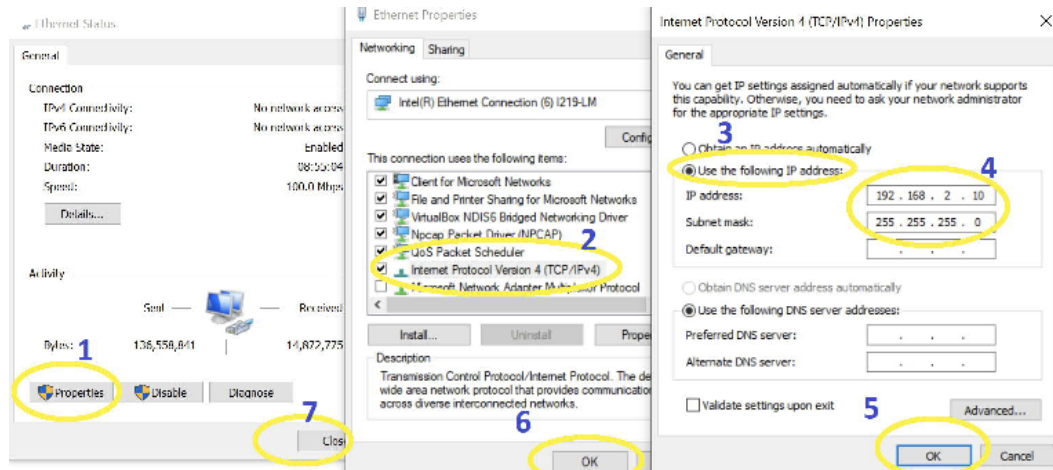
Subnet Mask: 255.255.255.0

D. Setup ethernet at PC/Laptop (for local intranet access).

First connect the Edge Gateway to PC/Laptop with ethernet cable. In PC/Laptop, open the “Network and Sharing Center” and then open the “Ethernet” network as shown below.



The web server is available only in Local view mode



Next, follow the steps in sequence of 1-7 as shown below:

- 1 – Open Properties in Ethernet Status window.
- 2 – open Internet Protocol Version (TCP/IPv4) in Ethernet Properties window.
- 3 – select “Use the following IP address” option.
- 4 – set the ip address and subnet mask.
- 5 – Press “OK” button in Internet Protocol Version 4 (TCP/IPv4) Properties windows.
- 6 – Press “OK” button in Ethernet Properties window.
- 7 – Press “Close” button in Ethernet Status window.

E. Install certificates & configure hostname in windows machine (please refer CSDG section no. )

Include if any certificate needed for CCT??

F. Link: <https://xxx.elgateway.abb.local> where xxx – is the last 3-digits of ABB device Serial number, please check the label of the ABB Ability™ Edge Industrial Gateway for serial number.

G. Web server default credentials to login into Web Server

User ID: OWNER@abb.com

User Password: 12345678

H. Fill the details as per instructions in the web page – fill all details and accept the terms & conditions.

I. The default dashboard will appear.

J. Now Owner can perform below tasks:

- Add widgets in the dashboard.
- Create new users & roles.



## 16.2 Navigation to web server

### a. Web Server Dashboard

- Only 1-dashboard & 28-widgets available in Web server with max. 15 widgets can be added to the dashboard at a time.
- By default, 7-widgets are available for User first login with widgets:
  - real-time power,
  - real-time voltage,
  - real-time current,
  - energy monitoring,
  - health overview,
  - device connectivity status,
  - asset list.

Then the default widget can be changed and deleted as customer need.

### b. All Equipment List.

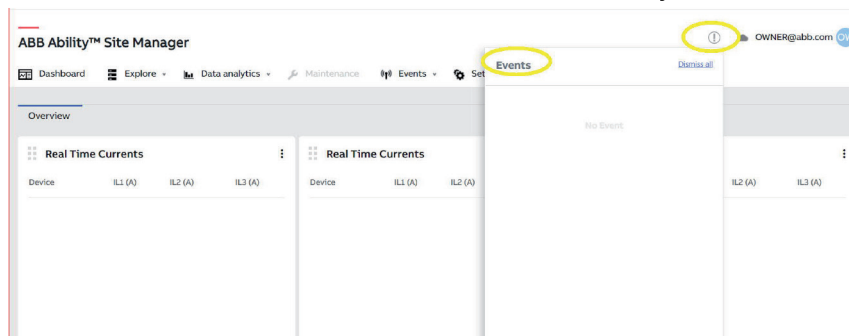
All provisioned devices will be available in this page.

### c. Data Analytics.

In this, any device, assets & sensors can be grouped with “Data Groups”.

### d. Events.

- a. We can create combination of alerts for each device.
- b. We can get the events for the created alerts in above step.
- c. Latest/recent event will be available on Dashboard directly.

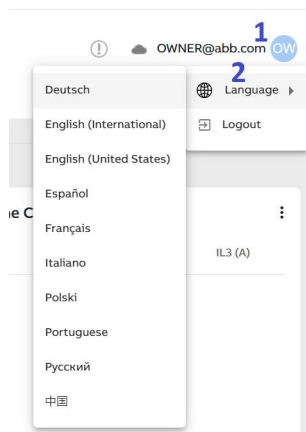


### e. Settings

- a. Site – In this Site information can edited/updated.
- b. Users and groups / Users.
  - i. Users – Owner can add new users with defined roles as per RBAC.
  - ii. Password Recovery – Owner can recover/reset password of any User.
- c. Billing – In this, billing details can be configured.
- d. Audit log – In this, only Owner & Manager have access to download audit log information of Gateway.

### f. Languages.

Total 10-languages are supported in Edge Gateway Web Server.







—

**ABB Ltd.**

Affolternstrasse 41  
CH-8050 Zurich  
Switzerland

**[solutions.abb/abb-ability-electrification](https://solutions.abb/abb-ability-electrification)**

The information contained in this document is for general information purposes only.

While ABB strives to keep the information up to date and correct, it makes no representations or warranties of any kind, expressed or implied, about the completeness, accuracy, reliability, suitability or availability with respect to the information, products, services, or related graphics contained in the document for any purpose.

Any reliance placed on such information is therefore strictly at your own risk.

ABB reserves the right to discontinue any product or service at any time.

© Copyright 2021 ABB. All rights reserved.