

CATALOG

# Motor protection and Control

AX09 ... AX150 contactors

Manual Motor Starters

Overload relays

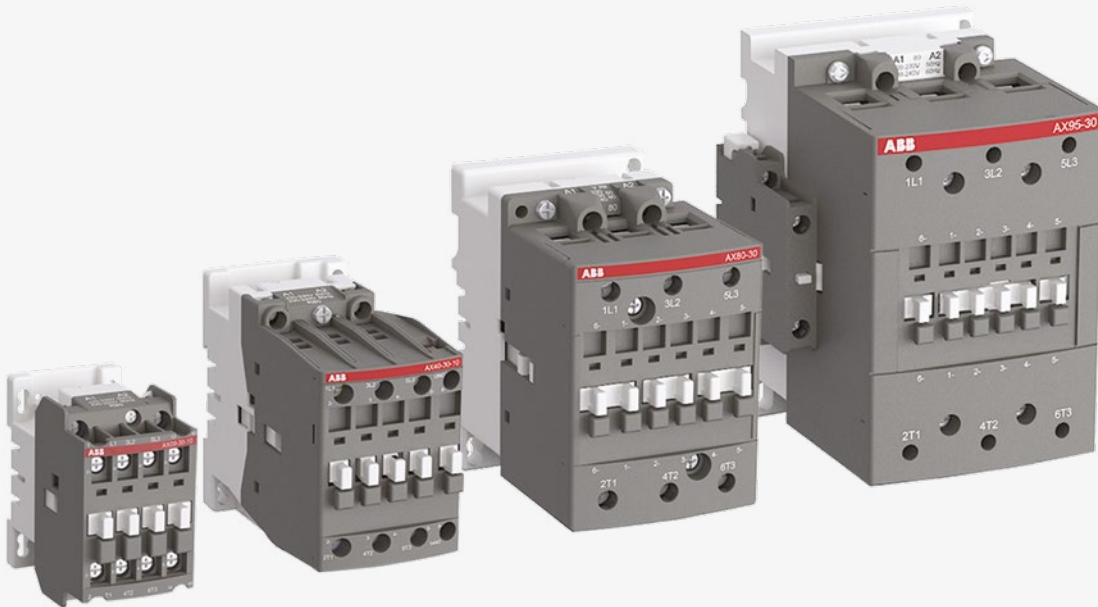

- Speed-up your projects
- Easy to install
- Continuous operation.

# Motor rated operational powers and currents

The currents given below concern standard three-phase four-pole cage motors (1500 r.p.m. at 50 Hz 1800 r.p.m. at 60 Hz). These values are given for guidance and may vary according to the motor manufacturer and depending on the number of poles.

IEC Motor nominal current: standardized values in grey colour (according to IEC 60947-4-1 Annex G)										
Motor power kW	220 V A	230 V A	240 V A	380 V A	400 V A	415 V A	440 V A	500 V A	660 V A	690 V A
0.06	0.37	0.35	0.34	0.21	0.2	0.19	0.18	0.16	0.13	0.12
0.09	0.54	0.52	0.50	0.32	0.3	0.29	0.26	0.24	0.18	0.17
0.12	0.73	0.7	0.67	0.46	0.44	0.42	0.39	0.32	0.24	0.23
0.18	1	1	1	0.63	0.6	0.58	0.53	0.48	0.37	0.35
0.25	1.6	1.5	1.4	0.9	0.85	0.82	0.74	0.68	0.51	0.49
0.37	2.0	1.9	1.8	1.2	1.1	1.1	1	0.88	0.67	0.64
0.55	2.7	2.6	2.5	1.6	1.5	1.4	1.3	1.2	0.91	0.87
0.75	3.5	3.3	3.2	2.0	1.9	1.8	1.7	1.5	1.15	1.1
1.1	4.9	4.7	4.5	2.8	2.7	2.6	2.4	2.2	1.7	1.6
1.5	6.6	6.3	6	3.8	3.6	3.5	3.2	2.9	2.2	2.1
2.2	8.9	8.5	8.1	5.2	4.9	4.7	4.3	3.9	2.9	2.8
3	11.8	11.3	10.8	6.8	6.5	6.3	5.7	5.2	4	3.8
4	15.7	15	14.4	8.9	8.5	8.2	7.4	6.8	5.1	4.9
5.5	20.9	20	19.2	12.1	11.5	11.1	10.1	9.2	7	6.7
7.5	28.2	27	25.9	16.3	15.5	14.9	13.6	12.4	9.3	8.9
11	39.7	38	36.4	23.2	22	21.2	19.3	17.6	13.4	12.8
15	53.3	51	48.9	30.5	29	28	25.4	23	17.8	17
18.5	63.8	61	58.5	36.8	35	33.7	30.7	28	22	21
22	75.3	72	69	43.2	41	39.5	35.9	33	25.1	24
30	100	96	92	57.9	55	53	48.2	44	33.5	32
37	120	115	110	69	66	64	58	53	40.8	39
45	146	140	134	84	80	77	70	64	49.1	47
55	177	169	162	102	97	93	85	78	59.6	57
75	240	230	220	139	132	127	116	106	81	77
90	291	278	266	168	160	154	140	128	97	93
110	355	340	326	205	195	188	171	156	118	113
132	418	400	383	242	230	222	202	184	140	134
160	509	487	467	295	280	270	245	224	169	162
200	637	609	584	368	350	337	307	280	212	203
250	782	748	717	453	430	414	377	344	261	250
315	983	940	901	568	540	520	473	432	327	313
355	1109	1061	1017	642	610	588	535	488	370	354
400	1255	1200	1150	726	690	665	605	552	418	400
500	1545	1478	1416	895	850	819	745	680	515	493
560	1727	1652	1583	1000	950	916	832	760	576	551
630	1928	1844	1767	1116	1060	1022	929	848	643	615
710	2164	2070	1984	1253	1190	1147	1043	952	721	690
800	2446	2340	2243	1417	1346	1297	1179	1076	815	780
900	2760	2640	2530	1598	1518	1463	1330	1214	920	880
1000	3042	2910	2789	1761	1673	1613	1466	1339	1014	970



# Motor protection and control

## Contactors, manual motor starters and overload relays

**OVERVIEW**  
P. 3

**MANUAL MOTOR  
STARTERS**  
P. 11

**AX CONTACTORS  
AND NX CONTACTOR  
RELAYS**  
P. 27

**OVERLOAD RELAYS**  
P. 87

**GENERAL  
TECHNICAL DATA**  
P. 101

**INDEX**  
P. 108

01

02

03

04

05

06



## AX contactors

The simplest way to get the control and performance you need



The AX contactor range offers exceptional reliability and performance in a brilliant, space-saving design. Use it for motor starting applications up to 150 A / 75 kW 400 V AC-3.



### Speed-up your projects

#### Simpler selection process

Speed up your projects with ABB's simpler order codes, faster identification, easier connection, and a complete and flexible range of accessories. Compliance process is faster too as AX contactors use environmentally friendly materials that comply with energy label.



### Easy to install

#### Faster fitting by design

ABB's smart design saves time with every detail. AX contactors are smaller and easier to handle. All terminals are delivered in open position so wiring is faster.

ABB's broad range provides the best configuration for the job. Single or multiple pole blocks are no problem. Front or side mounted auxiliary contact blocks are available as well.



### Continuous operation

#### Proven, secure, trusted

Trust a proven solution from a brand with 100 years of experience in contactors design and manufacture. ABB's AX range makes starting solutions that are more reliable – with type 2 coordination between contactors and short-circuit protection devices guaranteed.

ABB's mechanically linked contacts and mirror contact functions make control circuits safe and reliable.

## Save time when building motor starting solution with AX contactors

Complete range compatible with ABB low voltage solutions



### Tested component combinations

Using ABB's coordination tables gives users a choice of fully tested assemblies and product combinations. It's quicker and easier to build DOL starters, reversing starters or star delta starters using ABB's range of AX contactors, manual motor starters, molded case breakers, fuses and overload relays.

### Create smart starters

AX contactors look more professional and, together with connection kits, they provide a better finish than cables or bus bars.

### Save time

ABB starters come with connection kits to make assembly simpler and faster. The kits save time on cable preparation and eliminate fitment and wiring error risks.

# AX contactors

## Features and benefits

### Every detail designed for you

Smart packaging design makes it simpler to identify the product you need – the product type, coil voltage, order code and bar code are all clearly displayed. The same goes when the product is unboxed. A quick glance at the front tells you what product, contactor type and coil voltage you have. Terminal markings are also plainly visible. The rated values and main approvals are ready to read on the side.

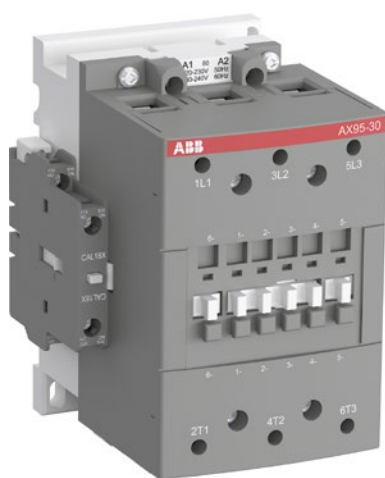

### Certified, trusted contactors

ABB's AX contactors are designed in compliance with IEC 60947-4-1 and GB 14048-4 requirements. These trusted safety products have CB certification, CE marking as well as UL, CCC and CCS approval.



### Easier to connect

ABB designed its AX contactors so that all screw-heads are accessible from the front. One Pozidriv #2 screwdriver fits every contactor terminal and the complete accessory range. All main and auxiliary terminals can take one or two cables and contactors up to AX150 have three coil terminals for connection from the top or the bottom. Right out of the box, all terminals are ready in the open position for wiring.

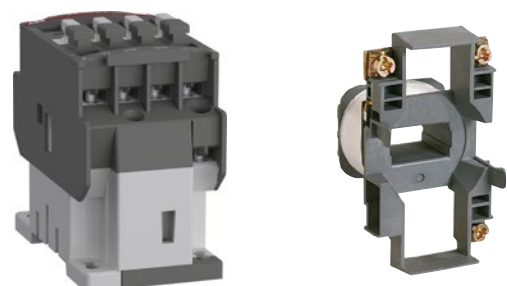

### Environmentally sound

The design and production of ABB's AX contactor range follows ISO 14000 processes. The raw materials are free of red phosphorous, cadmium, mercury, brominated substances (PBB, PBPE) and other pollutants. AX contactors and main accessories also comply with the European directive ROHS 2011/65/EU incl. 2015/863/EU. The same goes for the packaging design. The box is fully recyclable and clearly marked to aid correct disposal.



# AX contactors

## Features and benefits

### Auxiliaries made simple, secure and flexible

Common interfaces that are clip-on and self-locking make mounting ABB contactors simpler. Its AX contactor range uses the same front-mounted auxiliary contact blocks up to AX150 and the same side-mounted auxiliary contact blocks up to AX80. To maximize flexibility, users can front-mount any single- or four-pole auxiliary contact block. Two-pole auxiliary contact block can be side-mounted.

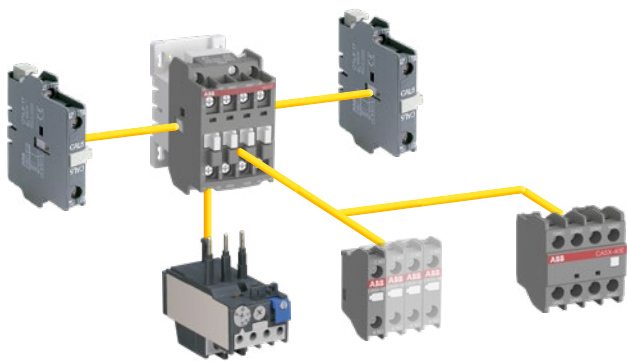

### Protect control circuits and save space

ABB's AX range makes surge suppressors easy to snap on and connect. Designing contactor coils to them fit within their overall dimensions without additional space requirements. The smart design and proven technologies provide safe protection for circuits against over-voltages when the contactor opens.

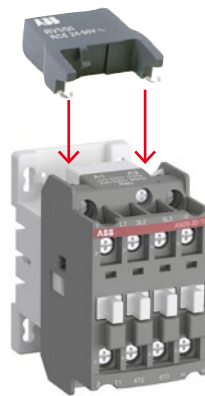

### Complete range of multi-function overload relays

ABB's complete range of thermal overload relays provides class 10 protection and key functions including:

- Motor protection against overload and phase failure
- Automatic and manual reset both included
- Test and stop functions

ABB's thermal overload relays are suitable for three-phase or single-phase motor applications with temperature compensation between -25 °C and +55 °C.

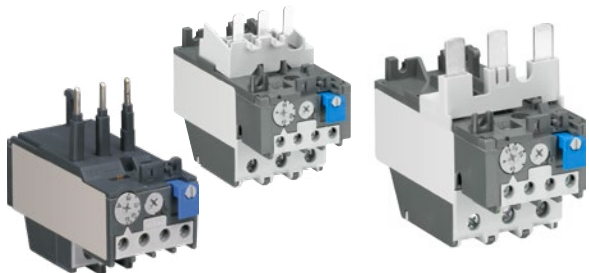

### Safe and reliable control circuits

A white contact carrier ensures the contactor state is visible at all times, even with accessories mounted.

Built-in and add-on auxiliary contacts provide reliable low signal contacts for 12 V 3 mA. Failure rates are less than 10<sup>-6</sup> according to IEC 60947-5-1.

Mechanically linked functions are available with 4-pole blocks CA5X. Mirror contacts are available with built-in NC contacts for AX09 ... AX40 and side-mounted blocks CAL5-11X and 4-pole blocks CA5X for AX09 ... AX80.

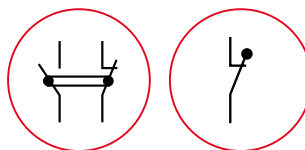





# 3-pole contactors for motor control and power switching



IEC	AC-3 Rated operational power $\theta \leq 55^\circ\text{C}$ , 400 V	kW	4	5.5	7.5	11	15	18.5
AC Control supply		Type	<b>AX09</b>	<b>AX12</b>	<b>AX18</b>	<b>AX25</b>	<b>AX32</b>	<b>AX40</b>
IEC	AC-3 Rated operational current $\theta \leq 55^\circ\text{C}$ , 400 V	A	9	12	18	25	32	40
	AC-1 Rated operational current $\theta \leq 40^\circ\text{C}$ , 690 V	A	22	25	27	32	55	60

## Main accessories

Auxiliary contact blocks	Front mounting	CA5X-10 (1 x N.O.) CA5X-01 (1 x N.C.) CA5X-4 pole (add on block with 4 contacts N.O. or N.C. combination)
	Side mounting	CAL5X-11 (1 x N.O. + 1 x N.C.)
Timers	Electronic	TEF5-ON TEF5-OFF
Interlocking units	Mechanical	VM5-1
	Mechanical / Electrical	VE5-1
Surge suppressors	Varistor (AC / DC)	RV5 (24...440 V)
	RC type (AC)	RC5-1 (24...440 V)

## Overload relays

Thermal relays	 Class 10A	TA25DU-M (0.1...32A)
		TA42DU-M (18...42 A)

(1) The max. AC-3 operational current is 23 A for AX25 with TA25DU-25M.

(2) The max. AC-3 operational current is 74 A for AX80 with TA75DU-80M.

## Manual motor starters

	Thermal / magnetic protection Class 10	MS116 (0.10...32 A) Ics up to 50 kA for class 10A
Accessories	For contactor mounting	BEA16/116 (3)
		BEA25/116 (3)
		BEA25/132 (4)

(3) AX.. with MS116-0.16 ... MS116-16

(4) AX25 with MS116-20 ... MS116-32



	22	30	37	45	55	75
	<b>AX50</b>	<b>AX65</b>	<b>AX80</b>	<b>AX95</b>	<b>AX115</b>	<b>AX150</b>
	50	65	80	96	115	150
	100	115	125	145	160	190

	CAL18X-11 (1 x N.O. + 1 x N.C.)
--	---------------------------------

	VE5-2
--	-------

	RC5-2 (24...440 V)
--	--------------------

	TA75DU-M (18...80 A) (2)	TA80DU-M
--	--------------------------	----------

		TA110DU-M
--	--	-----------

**Short-circuit protection devices**

MCCB and switch fuses





---

# Manual motor starters

	<b>Overview</b>
12	Overview
	<b>Ordering details – 0.10 to 65 A with thermal and electromagnetic protection</b>
13	MS116 manual motor starters
14	<b>Technical data</b>
18	<b>Main accessories</b>
25	<b>General accessories</b>

## Manual motor starters

### Overview



Type	MS116
Thermal and electromagnetic protection	Yes
Electromagnetic protection	-
Phase loss sensitivity	Yes
Switch position	ON/OFF
Magnetic trip indication	-
Lockable handle without accessories	-
Disconnecting feature	Yes
Width	45 mm
Rated operational current I <sub>e</sub>	0.16 ... 32 A
Setting range	0.1 ... 32 A
Ambient air temperature	-25 ... +55°C (1)

(1) Compensated

### Main accessories

Auxiliary contact blocks	HKF1, HK1	
Signalling contact	for tripped alarm	SK1
	for short circuit alarm	-
Shunt trip	AA1	
Undervoltage release	UA1	

### Table for short circuit ratings for 400/415 V

Standard range MS116				
Selection parameters				
Rated operational power	Setting range for thermal release	Type	Short-circuit breaking capacity	
			I <sub>cu</sub>	I <sub>cs</sub>
-	0.1 ... 0.16 A	MS116-0.16	50 kA	50 kA
0.06 kW	0.16 ... 0.25 A	MS116-0.25	50 kA	50 kA
0.09 kW	0.25 ... 0.4 A	MS116-0.4	50 kA	50 kA
0.18 kW	0.4 ... 0.63 A	MS116-0.63	50 kA	50 kA
0.25 kW	0.63 ... 1.0 A	MS116-1.0	50 kA	50 kA
0.55 kW	1.0...1.6 A	MS116-1.6	50 kA	50 kA
0.75 kW	1.6...2.5 A	MS116-2.5	50 kA	50 kA
1.5 kW	2.5...4.0 A	MS116-4.0	50 kA	50 kA
2.2 kW	4.0...6.3 A	MS116-6.3	50 kA	50 kA
4.0 kW	6.3...10 A	MS116-10	50 kA	50 kA
5.5 kW	8...12 A	MS116-12	25 kA	25 kA
7.5 kW	10...16 A	MS116-16	16 kA	16 kA
7.5 kW	16 ... 20 A	MS116-20	15 kA	10 kA
11 kW	20 ... 25 A	MS116-25	15 kA	10 kA
15 kW	25 ... 32 A	MS116-32	10 kA	10 kA

# MS116 manual motor starters

0.10 to 32 A - with thermal and electromagnetic protection



MS116-16



MS116-25



MS116-0.16-HKF1-11



MS116-32-HKF1-11

MS116 is a compact and economic range for motor protection up to 15 kW (400 V) / 32 A in width of 45 mm. Further features are the build-in disconnect function, temperature compensation, trip-free mechanism and a rotary handle with a clear switch position indication. The manual motor starter is suitable for three- and single phase applications. Auxiliary contacts, signaling contacts, undervoltage releases, shunt trips, power in-feed blocks and locking devices for protection against unauthorized changes are available as accessory. These are suitable throughout the MS116 range.

Rated operational power 400 V	Setting range	Short-circuit breaking capacity Ics at 400 V AC	Rated instantaneous short-circuit current setting Ii	Type	Order code	Weight (1 pce)
AC-3 kW	A	kA	A			
0.03(2)	0.10 ... 0.16	50	2.00 (1)	MS116-0.16	1SAM250000R1001	0.225
0.06	0.16 ... 0.25	50	3.10 (1)	MS116-0.25	1SAM250000R1002	0.225
0.09	0.25 ... 0.40	50	5.00 (1)	MS116-0.4	1SAM250000R1003	0.225
0.18	0.40 ... 0.63	50	7.90 (1)	MS116-0.63	1SAM250000R1004	0.225
0.25	0.63 ... 1.00	50	12.5 (1)	MS116-1.0	1SAM250000R1005	0.225
0.55	1.00 ... 1.60	50	20.0 (1)	MS116-1.6	1SAM250000R1006	0.265
0.75	1.60 ... 2.50	50	31.3 (1)	MS116-2.5	1SAM250000R1007	0.265
1.50	2.50 ... 4.00	50	50.0	MS116-4.0	1SAM250000R1008	0.265
2.20	4.00 ... 6.30	50	78.8	MS116-6.3	1SAM250000R1009	0.265
4.00	6.30 ... 10.0	50	150	MS116-10	1SAM250000R1010	0.265
5.50	8.00 ... 12.0	25	180	MS116-12	1SAM250000R1012	0.265
7.50	10.0 ... 16.0	16	240	MS116-16	1SAM250000R1011	0.265
7.50	16.0 ... 20.0	10	300	MS116-20	1SAM250000R1013	0.310
11.0	20.0 ... 25.0	10	375	MS116-25	1SAM250000R1014	0.310
15.0	25.0 ... 32.0	10	480	MS116-32	1SAM250000R1015	0.310
0.03(2)	0.10 ... 0.16	50	2.00 (1)	MS116-0.16-HKF1-11	1SAM250005R1001	0.240
0.06	0.16 ... 0.25	50	3.10 (1)	MS116-0.25-HKF1-11	1SAM250005R1002	0.240
0.09	0.25 ... 0.40	50	5.00 (1)	MS116-0.4-HKF1-11	1SAM250005R1003	0.240
0.18	0.40 ... 0.63	50	7.90 (1)	MS116-0.63-HKF1-11	1SAM250005R1004	0.240
0.25	0.63 ... 1.00	50	12.5 (1)	MS116-1.0-HKF1-11	1SAM250005R1005	0.240
0.55	1.00 ... 1.60	50	20.0 (1)	MS116-1.6-HKF1-11	1SAM250005R1006	0.280
0.75	1.60 ... 2.50	50	31.3 (1)	MS116-2.5-HKF1-11	1SAM250005R1007	0.280
1.50	2.50 ... 4.00	50	50.0	MS116-4.0-HKF1-11	1SAM250005R1008	0.280
2.20	4.00 ... 6.30	50	78.8	MS116-6.3-HKF1-11	1SAM250005R1009	0.280
4.00	6.30 ... 10.0	50	150	MS116-10.0-HKF1-11	1SAM250005R1010	0.280
5.50	8.00 ... 12.0	25	180	MS116-12.0-HKF1-11	1SAM250005R1012	0.280
7.50	10.0 ... 16.0	16	240	MS116-16.0-HKF1-11	1SAM250005R1011	0.280
7.50	16.0 ... 20.0	10	300	MS116-20-HKF1-11	1SAM250005R1013	0.326
11.0	20.0 ... 25.0	10	375	MS116-25-HKF1-11	1SAM250005R1014	0.326
15.0	25.0 ... 32.0	10	480	MS116-32-HKF1-11	1SAM250005R1015	0.326

Note: Manual motor starters should always be selected so that the actual motor current is within the setting range.

(1) For other voltage version see voltage code table.

(2) 690 V

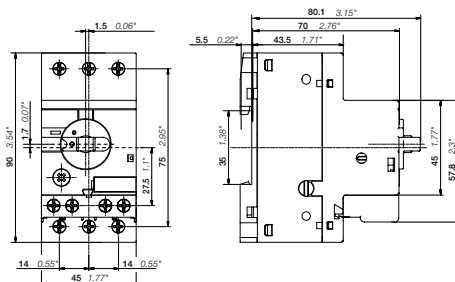

MS116 ≤ 16 A & MS116-HK1-11 ≤ 16 A

Main dimensions mm, inches

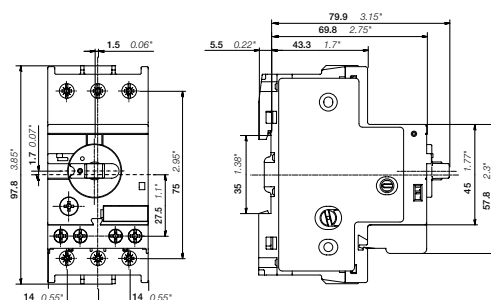

MS116 ≤ 20 A & MS116-HK1-11 ≤ 20 A

# MS116

## Technical data

### Main circuit - Utilization characteristics according to IEC/EN

Type	MS116	
Standards	IEC/EN 60947-2, IEC/EN 60947-4-1, IEC/EN 60947-1	
Rated operation voltage Ue	690 V AC	
Rated frequency	50/60 Hz	
Operational frequency	50/60 Hz	
Trip class	10A	
Number of poles	3	
Duty time	100%	
Mechanical durability	100000 cycles	
Electrical durability	up to 16 A	100000 cycles
	20 ... 65 A	50000 cycles
Rated impulse withstand voltage Uimp	6 kV	
Rated insulation voltage Ui	690 V	
Rated operational current Ie	See ordering details	
Rated operational current DC-5 Ie 3 conducting paths in series up to 250 V	-	
Rated instantaneous short-circuit current setting Ii	See ordering details	
Rated service short-circuit breaking capacity Ics	See table "Short-circuit breaking capacity and back-up fuses"	
Rated ultimate short-circuit breaking capacity Icu	See table "Short-circuit breaking capacity and back-up fuses"	
Rated service short-circuit breaking capacity DC Ics 3 conducting paths in series up to 250 V	-	

### Short-circuit breaking capacity and back-up fuses

ICS Rated service short-circuit breaking capacity

ICU Rated ultimate short-circuit breaking capacity

ICC Prospective short-circuit current at installation location

Note: Maximum rated current of the back-up fuses if  $I_{cc} > I_{cs}$

Type	230 V AC			400 V AC			440 V AC			500 V AC			690 V AC		
	I <sub>cs</sub> kA	I <sub>cu</sub> kA	gG, aM A	I <sub>cs</sub> kA	I <sub>cu</sub> kA	gG, aM A	I <sub>cs</sub> kA	I <sub>cu</sub> kA	gG, aM A	I <sub>cs</sub> kA	I <sub>cu</sub> kA	gG, aM A	I <sub>cs</sub> kA	I <sub>cu</sub> kA	gG, aM A
MS116-0.16	50	50	-(1)	50	50	-(1)	30	30	-(1)	30	30	-(1)	30	30	-(1)
MS116-0.25	50	50	-(1)	50	50	-(1)	30	30	-(1)	30	30	-(1)	30	30	-(1)
MS116-0.4	50	50	-(1)	50	50	-(1)	30	30	-(1)	30	30	-(1)	30	30	-(1)
MS116-0.63	50	50	-(1)	50	50	-(1)	30	30	-(1)	30	30	-(1)	30	30	-(1)
MS116-1.0	50	50	-(1)	50	50	-(1)	30	30	-(1)	30	30	-(1)	30	30	-(1)
MS116-1.6	50	50	-(1)	50	50	-(1)	30	30	-(1)	30	30	-(1)	30	30	-(1)
MS116-2.5	50	50	-(1)	50	50	-(1)	10	10	25(2)	10	10	25(2)	5	5	25(2)
MS116-4.0	50	50	-(1)	50	50	-(1)	6	6	25(2)	6	6	25(2)	2	2	25(2)
MS116-6.3	50	50	-(1)	50	50	-(1)	6	6	63(2)	6	6	63(2)	2	2	40(2)
MS116-10	50	50	-(1)	50	50	-(1)	6	6	63(2)	6	6	63(2)	2	2	50(2)
MS116-12	25	25	80(2)	25	25	80(2)	6	6	63(2)	6	6	63(2)	2	2	50(2)
MS116-16	16	16	80(2)	16	16	80(2)	4	4	63(2)	4	4	63(2)	2	2	63(2)
MS116-20	10	15	125(2)	10	15	125(2)	3	6	125(2)	3	4	125(2)	2	2	80(2)
MS116-25	10	15	125(2)	10	15	125(2)	3	6	125(2)	3	4	125(2)	2	2	100(2)
MS116-32	10	10	125(2)	10	10	125(2)	3	6	125(2)	3	4	125(2)	2	2	100(2)

(1) No back-up fuse required, because short-circuit proof up to 50 kA

(2) Rated back-up fuse for short-circuit up to 50 kA



# MS116

## Technical data

### Main circuit - Utilization characteristics according to UL/CSA

Type	MS116	
Standards	UL 60947-1, UL 60947-4-1 (UL 508), CSA C22.2 No.60947-4-1 (CSA C22.2 No.14)	
Rated operation voltage U <sub>e</sub> acc. to UL/CSA	600 V AC	
Trip class	10 A	
Motor ratings (1)	Horsepower	See table "Motor ratings, three phase"
	Full Load Amps (FLA)	See table "Motor ratings, three phase"
	Locked Rotor Amps (LRA)	See table "Motor ratings, three phase"

(1) See product data sheets for UL/CSA single phase motor and general use (AC-1) ratings.

### UL/CSA ratings overview

Type	MS116
Manual Motor Controller	X
Manual Motor Controller, Suitable as Motor Disconnect	X
Manual Motor Controller, Suitable for use in Group Installations	X
Manual Motor Controller, Suitable for Tap Conductor Protection in Group Installations	-
Manual self-protected Combination Motor Controller (Type E)	-
Combination Motor Controller (Type F)	-

### UL/CSA Motor ratings, three phase – MS116

Type	200 V AC			208 V AC			220 ... 240 V AC			440 ... 480 V AC			550 ... 600 V AC		
	hp	FLA	LRA	hp	FLA	LRA	hp	FLA	LRA	hp	FLA	LRA	hp	FLA	LRA
MS116-0.16	-	0.16	0.96	-	0.16	0.96	-	0.16	0.96	-	0.16	0.96	-	0.16	0.96
MS116-0.25	-	0.25	1.5	-	0.25	1.5	-	0.25	1.5	-	0.25	1.5	-	0.25	1.5
MS116-0.40	-	0.4	2.4	-	0.4	2.4	-	0.4	2.4	-	0.4	2.4	-	0.4	2.4
MS116-0.63	-	0.63	3.78	-	0.63	3.78	-	0.63	3.78	-	0.63	3.78	-	0.63	3.78
MS116-1.0	-	1	6	-	1	6	-	1	6	-	1	6	1/2	1	6
MS116-1.6	-	1.6	9.6	-	1.6	9.6	-	1.6	9.6	3/4	1.6	9.6	3/4	1.6	9.6
MS116-2.5	1/2	2.5	15	1/2	2.5	15	1/2	2.5	15	1	2.5	15	1 1/2	2.5	15
MS116-4.0	3/4	4	24	3/4	4	24	1	4	24	2	4	24	3	3.9	25.6
MS116-6.3	1	6.3	37.8	1	6.3	37.8	1 1/2	6.3	37.8	3	4.8	32	5	6.1	36.8
MS116-10	2	7.8	57.5	2	7.5	55	3	9.6	64	5	7.6	46	7 1/2	9	50.8
MS116-12	3	11	73.6	3	10.6	71	3	9.6	64	7 1/2	11	63.5	10	11	64.8
MS116-16	3	11	73.6	3	10.6	71	5	15.2	92	10	14	81	10	11	64.8
MS116-20	5	17.5	105.8	5	16.7	102	5	15.2	92	10	14	81	15	17	93
MS116-25	5	17.5	105.8	7 1/2	24.2	140	7 1/2	22	127	15	21	116	20	22	116
MS116-32	7 1/2	25.3	146	10	30.8	179	10	28	162	20	27	145	25	27	146

## MS116

### Technical data

#### UL/CSA Maximum short-circuit current ratings – MS116

Type	Manual Motor Controllers					
	Branch circuit protection, max. size per NEC/CEC(1)		for motor disconnect(2)		for group installations	
	Fuses	Circuit breaker	480 V	600 V	480 V	600 V
	A	A	kA	kA	kA	kA
MS116-0.16	100	-	30	5	30	5
MS116-0.25	100	-	30	5	30	5
MS116-0.40	100	-	30	5	30	5
MS116-0.63	100	-	30	5	30	5
MS116-1.0	100	-	30	5	30	5
MS116-1.6	100	-	30	5	30	5
MS116-2.5	100	-	30	5	30	5
MS116-4.0	100	-	18	5	18	5
MS116-6.3	100	-	18	5	18	5
MS116-10	100	-	18	5	18	5
MS116-12	100	-	18	5	18	5
MS116-16	100	-	18	5	18	5
MS116-20	100	-	18	5	18	5
MS116-25	100	-	18	5	18	5
MS116-32	100	-	18	5	18	5

(1) NEC: NFPA®70 National Electrical Code®; CEC: CSA C22.1 Canadian Electrical Code.

(2) Suitable as motor disconnect only when provide with padlock adaptor SA1 or SA3.

# MS116





## Technical data

### General technical data

Type	MS116	
Pollution degree	3	
Phase loss sensitivity	Yes	
Disconnect function acc. to IEC/EN 60947-2	Yes	
Ambient air temperature		
Operation	Open - compensated	-25 ... +55 °C
	Open	-25 ... +70 °C
	Enclosed (IB132 <sup>(1)</sup> )	0 ... +40 °C
Storage	-50 ... +80 °C	
Ambient air temperature compensation	Acc. to IEC/EN60947-4-1	
Maximum operating altitude permissible	2000 m	
Resistance to shock acc. to IEC 60068-2-27	25g / 11 ms	
Resistance to vibrations acc. to IEC 60068-2-6	5g / 3 ... 150 Hz	
Mounting position	Position 1-6 (optional for single mounting)	
Mounting	DIN-rail (EN 60715)	
Group mounting	On request	
Recommended screw for mounting plate	-	
Screw torque for mounting plate	-	
Minimum distance to other units same type	Horizontal	0 mm
	Vertical	150 mm
Minimum distance to electrical conductive board	Horizontal, up to 400 V	0 mm
	Horizontal, up to 690 V	> 1.5 mm
	Vertical	75 mm
Degree of protection	Housing	IP20
	Main circuit terminals	IP10

(1) not suitable for MS165 and MO165

### Connecting characteristics - Main circuit

Type	MS116 ≤ 16 A		MS116 ≥ 20 A
Connecting capacity			
 Rigid	1 or 2 x	1 ... 4 mm <sup>2</sup>	2.5 ... 6 mm <sup>2</sup>
 Flexible with ferrule	1 or 2 x	0.75 ... 2.5 mm <sup>2</sup>	1 ... 6 mm <sup>2</sup>
 Flexible with insulated ferrule	1 or 2 x	0.75 ... 2.5 mm <sup>2</sup>	1 ... 6 mm <sup>2</sup>
 Flexible	1 or 2 x	0.75 ... 2.5 mm <sup>2</sup>	1 ... 6 mm <sup>2</sup>
Stranded acc. to UL/CSA	1 or 2 x	AWG 16-12	AWG 16-8
Stripping length	9 mm		10 mm
Tightening torque	0.8 ... 1.2 Nm / 10 ... 12 lb.in		2.0 Nm / 18 lb.in
Recommended screw driver	Pozidriv 2		Pozidriv 2

## Main accessories

### MS116



HKF1-11

1SBC101208F0014



HK1-11

1SBC101209F0014



SK1-11

1SBC101210F0014

MS116 can be equipped with auxiliary contacts for lateral/front mounting, signaling contacts for lateral mounting, undervoltage releases and shunt trips. Two different signaling contacts are available. The accessories can be fitted wiring free and without tools. A variety of combinations is possible as required for the application. The auxiliary contacts change position with the main contacts. The signaling contact SK signals tripping regardless if it was caused by short-circuit or overload. The signaling contact CK signals tripping in case it was caused by short-circuit. Undervoltage releases are used for remote tripping of the manual motor starters especially for emergency stop circuits. Shunt trips release the MMS used for remote tripping. These main accessories are suitable throughout the MS116 range.

Suitable for	Auxiliary contacts N.O.	Auxiliary contacts N.C.	Description	Type	Order code	Pkg qty	Weight (1 pce)
--------------	-------------------------	-------------------------	-------------	------	------------	---------	----------------

#### Auxiliary contacts – mountable on the front

MS116	1	1		HKF1-11	1SAM201901R1001	10	0.015
	1	0		HKF1-10	1SAM201901R1003	10	0.013
	0	1		HKF1-01	1SAM201901R1004	10	0.013
	2	0		HKF1-20	1SAM201901R1002	10	0.015

#### Auxiliary contacts – mountable on the right

MS116	1	1	max. 2 pieces	HK1-11	1SAM201902R1001	2	0.035
	2	0	max. 2 pieces	HK1-20	1SAM201902R1002	2	0.035
	0	2	max. 2 pieces	HK1-02	1SAM201902R1003	2	0.035
	2	0	with lead contacts	HK1-20L	1SAM201902R1004	2	0.035

#### Signaling contacts – mountable on the right

MS116	1	1	for tripped alarm, max. 2 pieces	SK1-11	1SAM201903R1001	2	0.035
	2	0	for tripped alarm, max. 2 pieces	SK1-20	1SAM201903R1002	2	0.035
	0	2	for tripped alarm, max. 2 pieces	SK1-02	1SAM201903R1003	2	0.035

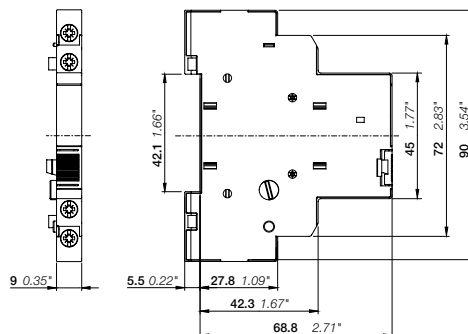

HK1

Main dimensions mm, inches

## Main accessories

### MS116



AA1-24



UA1-24

Suitable for	Rated control supply voltage		Type	Order code	Pkg qty	Weight (1 pce) kg
	50 Hz V AC	60 Hz V AC				

#### Shunt trips - mountable on the left

MS116	20 ... 24	20 ... 24	AA1-24	1SAM201910R1001	1	0.100
	110	110	AA1-110	1SAM201910R1002	1	0.100
	200 ... 240	200 ... 240	AA1-230	1SAM201910R1003	1	0.100
	350 ... 415	350 ... 415	AA1-400	1SAM201910R1004	1	0.100

#### Undervoltage releases - mountable on the left

MS116	20	24	UA1-20	1SAM201904R1010	1	0.100
	24	-	UA1-24	1SAM201904R1001	1	0.100
	48	-	UA1-48	1SAM201904R1002	1	0.100
	60	-	UA1-60	1SAM201904R1003	1	0.100
	110	120	UA1-110	1SAM201904R1004	1	0.100
	-	208	UA1-208	1SAM201904R1008	1	0.100
	230	240	UA1-230	1SAM201904R1005	1	0.100
	400	-	UA1-400	1SAM201904R1006	1	0.100
	415	480	UA1-415	1SAM201904R1007	1	0.100
	-	575	UA1-575	1SAM201904R1009	1	0.100

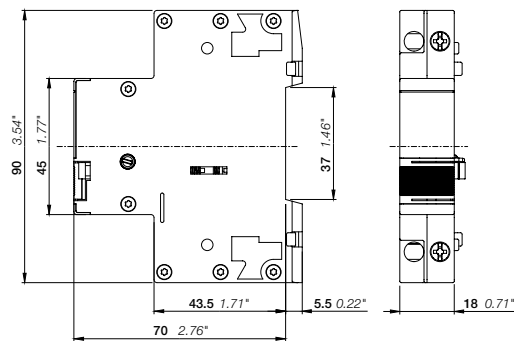

AA1, UA1

Main dimensions mm, inches

## Main accessories

### MS116





#### General technical data

Type		HK1, SK1, CK1	HKF1
Standards		IEC/EN 60947-2, IEC/EN 60947-4-1, IEC/EN 60947-1	
Rated operational voltage U <sub>e</sub>		690 V AC / 600 V DC	250 V AC / 250 V DC
Conventional free-air thermal current I <sub>th</sub>		6 A	5 A
Rated frequency		50/60 Hz	
Rated impulse withstand voltage U <sub>imp</sub>		6 kV	
Rated insulation voltage U <sub>i</sub>		690 V AC	250 V AC
Pollution degree		3	
Ambient air temperature	Operation	-25 ... +70 °C	
	Storage	-50 ... +80 °C	
Resistance to shock acc. to IEC 60068-2-27		25g / 11 ms	
Resistance to vibrations acc. to IEC 60068-2-6		5g / 3 ... 150 Hz	
I <sub>e</sub> / Rated operational current AC-15 acc. to IEC/EN 60947-5-1 for utilization category	24 V, 120 V	6 A	3 A
	240 V	4 A	1.5 A
	400 V	3 A	-
	440 V, 690 V	1 A	-
I <sub>e</sub> / Rated operational current DC-13 acc. to IEC/EN 60947-5-1 for utilization category	24 V	2 A	1 A
	125 V	0.55 A	0.27 A
	250 V	0.27 A	0.11 A
	440 V, 600 V	0.15 A	-
Minimum switching capacity		17 V / 5 mA	
Short-circuit protective device	N.C., 95-96	10 A Type gG	
	N.O., 97-98	10 A Type gG	
Duty time		100 %	
Mounting		Right side of MMS	Front of MMS
Mounting positions		1-6	
Mechanical durability		50000 cycles	
Electrical durability		50000 cycles	

#### Contact utilization characteristics according to UL/CSA

Type		HK1, SK1, CK1	HKF1
Standards		UL 60947-1, UL 60947-4-1 (UL 508), CSA C22.2 No.60947-4-1 (CSA C22.2 No.14)	
Rated operational voltage U <sub>e</sub> acc. to UL/CSA		600 V AC / 600 V DC	250 V AC / 250 V DC
Pilot duty		A600, Q600	B300, Q300
	AC thermal rated current	10 A	5 A
AC maximum volt-ampere making		7200 VA	3600 VA
AC maximum volt-ampere breaking		720 VA	360 VA
DC thermal rated current		2.5 A	2.5 A
DC maximum volt-ampere making-breaking		69 VA	69 VA

#### Connecting characteristics - Auxiliary circuit

Type		HK1, SK1, CK1	HKF1
Connecting capacity			
 Rigid	1 or 2 x	1 ... 1.5 mm <sup>2</sup>	1 ... 2.5 mm <sup>2</sup>
 Flexible with ferrule	1 or 2 x	0.75 ... 1.5 mm <sup>2</sup>	
 Flexible with insulated ferrule	1 or 2 x	0.75 ... 1.5 mm <sup>2</sup>	
 Flexible	1 or 2 x	0.75 ... 1.5 mm <sup>2</sup>	
	Stranded acc. to UL/CSA	1 or 2 x	AWG 16-14
Stripping length		8 mm	
Tightening torque		0.8 ... 1.2 Nm / 7 lb.in	
Recommended screw driver		Pozidriv 2	





## Main accessories

### MS116

#### General technical data

Type	UA1		AA1
Standards	IEC/EN 60947-1, IEC/EN 60947-4-1, UL 60947-1, UL 60947-4-1 (UL 508), CSA C22.2 No.60947-4-1 (CSA C22.2 No.14)		
Rated control supply voltage	see ordering details		AA1-24: 20-24 V 50/60 Hz; 20-70 V 50/60 Hz KB = 5 s, 20-70 V DC KB = 5 s AA1-100: 110 V 50/60 Hz; 110-200 V 50/60 Hz KB = 5 s, 110-200 V DC KB = 5 s AA1-230: 200-240 V 50/60 Hz, 200-350 V 50/60 Hz KB = 5 s, 200-350 V DC KB = 5 s AA1-400: 350-415 V 50/60 Hz, 350-500 V 50/60 Hz KB = 5 s, 350-500 V DC KB = 5 s
Rated frequency	see ordering details		50/60 Hz, DC
Operating voltage	Tripping	0.35 ... 0.7 x Us	0.7 ... 1.1 x Us
	Coil operating voltage	0.85 ... 1.1 x Us	-
Power consumption	Pull-in	AC	on request
		DC	on request
	Holding	AC	on request
		DC	on request
Rated impulse withstand voltage Uimp	6 kV		6 kV
Rated insulation voltage Ui	690 V		690 V
Pollution degree	3		3
Ambient air temperature	Operation	-25 ... +60 °C	
	Storage	-50 ... +80 °C	
Resistance to shock acc. to IEC 60068-2-27	25g / 11 ms		25g / 11 ms
Resistance to vibrations acc. to IEC 60068-2-6	5g / 3 ... 150 Hz		5g / 3 ... 150 Hz
Mounting	left side of MMS		left side of MMS
Mounting positions	-		-

#### Connecting characteristics - Auxiliary circuit

Type	UA1		AA1
Connecting capacity			
 Rigid	1 or 2 x	1 ... 4 mm <sup>2</sup>	
 Flexible with ferrule	1 or 2 x	0.75 ... 2.5 mm <sup>2</sup>	
 Flexible with insulated ferrule	1x	0.75 ... 2.5 mm <sup>2</sup>	
	2x	0.75 ... 1.5 mm <sup>2</sup>	
 Flexible	1 or 2 x	0.75 ... 2.5 mm <sup>2</sup>	
	Stranded acc. to UL/CSA	1 or 2 x	AWG 16-12
Stripping length	10 mm		
Tightening torque	0.8 ... 1.2 Nm / 7 lb.in		
Recommended screw driver	Pozidriv 2		

## Main accessories

### MS116

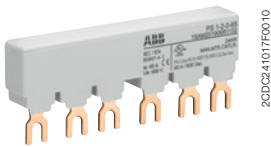

PS1-2-0-65

2CDC24107FF010

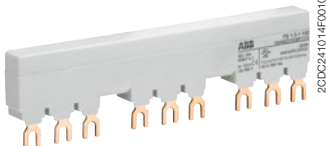

PS1-3-1-100

2CDC241014F010



S1-M1-25

1SBG10126RF0014



S1-M2-25

1SBG10126RF0014



SA2

2CDC241023RF0013



SA1

SK0108B91



PB1-1-32

2CDC241004F0014



S1-PB1-25

Three-phase busbars ensure a quick and safe connection and are therefore a cost effective solution. A variety of different three-phase busbars up to 100 A are in the assortment. Between 2 and 5 manual motor starters with none, one or two lateral auxiliary contacts can be connected. Different three-phase feeder terminals are available according to the application. Phase connecting links and phase power infeed blocks are also available for single-phase applications.

Suitable for	Rated operational current A	Number of MMS	Number of lateral aux.	Type	Order code	Pkg qty	Weight (1 pce) kg
--------------	--------------------------------	---------------	------------------------	------	------------	---------	----------------------

#### Three-phase busbars

MS116	65	2	0	PS1-2-0-65	1SAM201906R1102	10	0.034
	65	3	0	PS1-3-0-65	1SAM201906R1103	10	0.055
	65	4	0	PS1-4-0-65	1SAM201906R1104	10	0.077
	65	5	0	PS1-5-0-65	1SAM201906R1105	10	0.098
	65	2	1	PS1-2-1-65	1SAM201906R1112	10	0.036
	65	3	1	PS1-3-1-65	1SAM201906R1113	10	0.060
	65	4	1	PS1-4-1-65	1SAM201906R1114	10	0.087
	65	5	1	PS1-5-1-65	1SAM201906R1115	10	0.108
	65	2	2	PS1-2-2-65	1SAM201906R1122	10	0.040
	65	3	2	PS1-3-2-65	1SAM201906R1123	10	0.067
	65	4	2	PS1-4-2-65	1SAM201906R1124	10	0.095
	65	5	2	PS1-5-2-65	1SAM201906R1125	10	0.122
	MS116	100	3	0	PS1-3-0-100	1SAM201916R1103	10
100		4	0	PS1-4-0-100	1SAM201916R1104	10	0.117
100		5	0	PS1-5-0-100	1SAM201916R1105	10	0.154
100		3	1	PS1-3-1-100	1SAM201916R1113	10	0.094
100		4	1	PS1-4-1-100	1SAM201916R1114	10	0.134
100		5	1	PS1-5-1-100	1SAM201916R1115	10	0.172
100		3	2	PS1-3-2-100	1SAM201916R1123	10	0.105

Suitable for	Rated operational current A	Number of MMS mm <sup>2</sup>	Number of lateral aux.	Type	Order code	Pkg qty	Weight (1 pce) kg
--------------	--------------------------------	----------------------------------	------------------------	------	------------	---------	----------------------

#### Three-phase terminals

MS116	65	25	Flat	S1-M1-25	1SAM201907R1101	10	0.038
	65	25	High	S1-M2-25	1SAM201907R1102	10	0.051
	65	25	UL/CSA Type E/F and IEC	S1-M3-25	1SAM201907R1103	10	0.042
	100	35	UL/CSA Type E/F and IEC	S1-M3-35	1SAM201913R1103	10	0.060

Suitable for	Description	Type	Order code	Pkg qty	Weight (1 pce) kg
MS116	Protection cover for busbars	BS1-3	1SAM201908R1001	50	0.003
MS116	Screw fixing kit	FS116	1SAM201909R1001	1	0.020
MS116	Padlock + two keys	SA2	GJF1101903R0002	10	0.020
	Lock handle	SA1	GJF1101903R0001	10	0.003
	Lock handle box SA1/SA2	SA3	GJF1101903R0003	10	0.050

#### Accessories for single-phase connection (IEC only)

MS116	Phase connecting link	PB1-1-32	1SAM201914R1001	1	0.009
	Phase power infeed block	S1-PB1-25	1SAM201914R1002	1	0.013







## Main accessories

### MS116

#### General technical data

Type	PS1-xxx-65	PS1-xxx-100	S1-Mx-25	S1-Mx-35
Standards	IEC/EN 60947-4-1, IEC/EN 60947-1, UL 60947-1, UL 60947-4-1 (UL 508), CSA C22.2 No.60947-4-1 (CSA C22.2 No.14)			
Rated operational voltage U <sub>e</sub>	690 V			
Rated operational voltage U <sub>e</sub> acc. to UL/CSA	600 V AC			
Rated operational current I <sub>e</sub>	65 A	100 A	65 A	100 A
Rated operational current I <sub>e</sub> acc. to UL/CSA	65 A	92 A	65 A	92 A
Rated frequency	50/60 Hz			
Rated impulse withstand voltage U <sub>imp</sub>	6 kV			
Rated insulation voltage U <sub>i</sub>	690 V AC			
Pollution degree	3			
Cross-section	10 mm <sup>2</sup>	16 mm <sup>2</sup>	25 mm <sup>2</sup>	35 mm <sup>2</sup>
Ambient air temperature	Operation	-25 ... +70 °C		
	Storage	-50 ... +80 °C		
Resistance to shock acc. to IEC 60068-2-27	25g / 11 ms			
Resistance to vibrations acc. to IEC 60068-2-6	5g / 3 ... 150 Hz			

#### Electrical connection

Type	S1-Mx-25	S1-Mx-35
Connecting capacity		
 Rigid	1 x 6 ... 25 mm <sup>2</sup>	10 ... 35 mm <sup>2</sup>
 Flexible with ferrule	1 x 6 ... 16 mm <sup>2</sup>	10 ... 35 mm <sup>2</sup>
 Flexible with insulated ferrule	1 x 6 ... 16 mm <sup>2</sup>	10 ... 35 mm <sup>2</sup>
 Flexible	1 x 6 ... 16 mm <sup>2</sup>	10 ... 35 mm <sup>2</sup>
Stranded acc. to UL/CSA	1 x AWG 10-4	AWG 8-2
Stripping length	10 mm	12 mm
Tightening torque	2.5 Nm / 22 lb.in	4.5 Nm / 40 lb.in
Recommended screw driver	Pozidriv 2	Hexagon SW4

Technical data for PS2-xxx on request.

## Main accessories

### MS116



2CDC241004F0010

IB132-Y



2CDC241008F0010

IB132-G



2CDC241002F0010

DMS132-Y



2CDC241001F0010

DMS132-G

IB132 are IP65 (UL/CSA Type 12) enclosures for single MMS installation. Additional mounting of auxiliary and signaling contacts, shunt trips and undervoltage release is possible. The handle is lockable in OFF position. For detailed specification see installation instruction.

DMS132 are IP65 (UL/CSA Type 12) door mounting kits for MMS installation in any enclosure. Additional mounting of auxiliary, signaling, shunt trips and undervoltage release is possible. The handle is lockable in OFF position. For detailed specification see installation instruction.

Suitable for	Description	Color	Type	Order code	Pkg qty	Weight (1 pce) kg
<b>IP65 enclosures (UL/CSA Type 12)</b>						
MS116	Padlockable max. 3 padlocks with bail diameter 4 ... 6.5 mm	Yellow/red	IB132-Y	1SAM201911R1011	1	0.370
		Grey/black	IB132-G	1SAM201911R1010	1	0.370
<b>IP65 door mounting kits (UL/CSA Type 12)</b>						
MS116	Padlockable max. 3 padlocks with bail diameter 4 ... 6.5 mm	Yellow/red	DMS132-Y	1SAM201912R1011	1	0.170
		Grey/black	DMS132-G	1SAM201912R1010	1	0.170

Indication I-O-T and ON-OFF-T

Please check for further equipment chapter General accessories.

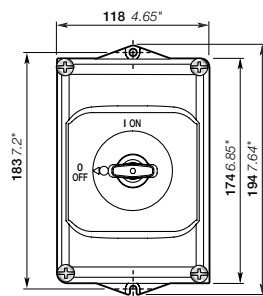

IB132

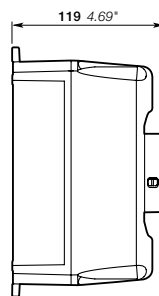

Main dimensions mm, inches

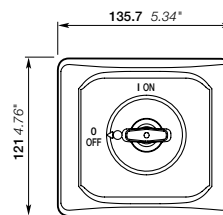

DMS132

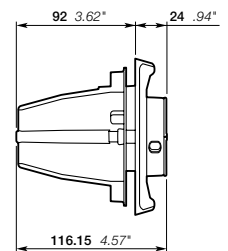

## General accessories

### MS116



2CDC241003F0011

MSHD-LB



2CDC24100280011

MSHD-LY



2CDC241004F0011

MSMN



2CDC241001F0012

MSH-AR



2CDC241017V0013

MSAH1

With this solution of door coupling rotary mechanism it is possible to operate a manual motor starter in the back of a switch cabinet from outside. The door coupling mechanism prevents opening of the door of a switch cabinet with the manual motor starter in ON position.

The complete mechanism includes handle, shaft, driver, shaft alignment ring and shaft supporter. Most accessories fit for 6 mm shafts with a maximum length of 180 mm. The degree of protection for handles MSHD is IP64 (UL/CSA Type 1, 3R, 12).

Suitable for	Description	Shaft length mm	Color	Type	Order code	Pkg qty	Weight (1 pce) kg
--------------	-------------	-----------------	-------	------	------------	---------	-------------------

#### Shafts

MS116	For MSHD handles. Shaft diameter 6 mm. Shaft extension for door coupling driver.	85		OXS6X85	1SCA101647R1001	1	0.020
		105		OXS6X105	1SCA108043R1001	1	0.020
		130		OXS6X130	1SCA101655R1001	1	0.030
		180		OXS6X180	1SCA101659R1001	1	0.040

#### IP64 handles (UL/CSA Type 1, 3R, 12)

MS116	Padlockable max. 3 padlocks with bail diameter 5 ... 8 mm, door interlock in ON position defeatable, for use with 6 mm OXS6...types up to 180 mm or driver shafts MSOX.		Black	MSHD-LB (1)	1SAM201920R1001	1	0.065
			Yellow	MSHD-LY (1)	1SAM201920R1002	1	0.065
			Black	MSHD-LTB (2)	1SAM201920R1011	1	0.065
			Yellow	MSHD-LTY (2)	1SAM201920R1012	1	0.065

#### Driver

MS116	Coupling driver for use with 6 mm OXS6... types up to 180 mm.			MSMN (3)	1SAM101923R0002	1	0.002
				MSMNO (4)	1SAM101923R0012	1	0.002

#### Shaft alignment ring

MS116	The MSH-AR supports the long shafts for alignment to the handle inlet. It makes closing panel doors more easy. Use for OXS6X > 105 mm.			MSH-AR	1SAM201920R1000	1	0.010
-------	--	--	--	--------	-----------------	---	-------

#### Shaft supporter

MS116	With the MSAH1 it is possible to support the shaft in the extension of handle (MSHD). It is mandatory for the usage of shafts >130 mm.			MSAH1	1SAM201909R1021	1	0.035
-------	--	--	--	-------	-----------------	---	-------

- (1) Indication I-O and ON-OFF (recommended for MS116)
- (2) Indication I-O and ON-OFF + Trip indication
- (3) Coded - Positioning of ON indication dependent from mounting orientation of the MMS
- (4) Uncoded - Positioning of ON indication independent from mounting orientation of the MMS



# AX contactors and NX contactor relays

	<b>AX 3-pole contactors</b>
28	Ordering details 3-pole contactors
34	Main accessories
37	Technical data 3-pole contactors
46	DC circuit switching
47	Electrical durability and utilization categories
48	Electrical durability
51	Star-delta starting of three-phase asynchronous motors
53	Terminal marking and positioning
54	Dimensions
	<b>NX contactor relays</b>
58	Ordering details
59	Main accessories
60	Technical data
62	Terminal marking and positioning
	<b>Accessories for AX contactors and NX contactor relays</b>
64	Auxiliary contact blocks
65	Technical data
68	Add-on auxiliary contacts
69	Electronic timers
72	Mechanical and electrical interlock units
74	Interface relays
76	Mechanical latching units
78	Surge suppressors for contactor coils
80	Additional terminal blocks
81	Function markers
82	Terminal connecting strips and shorting bars
83	Connection accessories for starting solutions
84	Phase to phase connections
85	<b>Voltage code table</b>

# AX09 ... AX12 3-pole contactors

## 4 to 5.5 kW

AC operated



AX09...AX12

1SBL01031V0014

AX09 ... AX12 contactors are mainly used for controlling 3-phase motors and power circuits up to 690 V AC.

These contactors are of the block type design with:

- 3 main poles and 1 built-in auxiliary contact
- control circuit: AC operated
- add-on auxiliary contact blocks for front or side mounting and a wide range of accessories.

IEC Rated operational power 400 V AC-3 kW	current $\theta \leq 40^\circ\text{C}$ AC-1 A	Rated control circuit voltage Uc (1)		Auxiliary contacts fitted 	Type	Order code	Weight (1 pce)  kg
		V 50 Hz	V 60 Hz				
4	22	24	24	1 0	AX09-30-10-81	1SBL901074R8110	0.340
				0 1	AX09-30-01-81	1SBL901074R8101	0.340
		105	110...127	1 0	AX09-30-10-26	1SBL901074R2610	0.340
				0 1	AX09-30-01-26	1SBL901074R2601	0.340
		200	200...220	1 0	AX09-30-10-75	1SBL901074R7510	0.340
				0 1	AX09-30-01-75	1SBL901074R7501	0.340
		380...400	400...415	1 0	AX09-30-10-85	1SBL901074R8510	0.340
				0 1	AX09-30-01-85	1SBL901074R8501	0.340
5.5	25	24	24	1 0	AX12-30-10-81	1SBL911074R8110	0.340
				0 1	AX12-30-01-81	1SBL911074R8101	0.340
		105	110...127	1 0	AX12-30-10-26	1SBL911074R2610	0.340
				0 1	AX12-30-01-26	1SBL911074R2601	0.340
		200	200...220	1 0	AX12-30-10-75	1SBL911074R7510	0.340
				0 1	AX12-30-01-75	1SBL911074R7501	0.340
		380...400	400...415	1 0	AX12-30-10-85	1SBL911074R8510	0.340
				0 1	AX12-30-01-85	1SBL911074R8501	0.340

(1) For other voltage version see voltage code table.

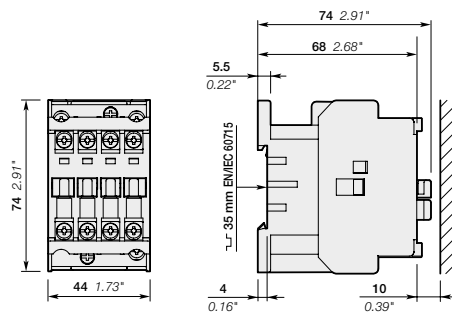

AX09, AX12

Main dimensions mm, inches

# AX18 ... AX25 3-pole contactors

## 7.5 to 11 kW

### AC operated



AX18

AX18 ... AX25 contactors are mainly used for controlling 3-phase motors and power circuits up to 690 V AC.

These contactors are of the block type design with:

- 3 main poles and 1 built-in auxiliary contact
- control circuit: AC operated
- add-on auxiliary contact blocks for front or side mounting and a wide range of accessories.

IEC		Rated control circuit voltage U <sub>c</sub> (1)		Auxiliary contacts fitted	Type	Order code	Weight (1 pce)				
Rated operational power 400 V AC-3 kW	current $\theta \leq 40^\circ\text{C}$ AC-1 A	V 50 Hz	V 60 Hz								
7.5	27	24	24	1 0	AX18-30-10-81	1SBL921074R8110	0.340				
				0 1	AX18-30-01-81	1SBL921074R8101	0.340				
		105	110...127	1 0	AX18-30-10-26	1SBL921074R2610	0.340				
				0 1	AX18-30-01-26	1SBL921074R2601	0.340				
		200	200...220	380...400	400...415	1 0	AX18-30-10-75	1SBL921074R7510	0.340		
						0 1	AX18-30-01-75	1SBL921074R7501	0.340		
		11	32	24	24	1 0	AX25-30-10-81	1SBL931074R8110	0.340		
						0 1	AX25-30-01-81	1SBL931074R8101	0.340		
105	110...127			200	200...220	380...400	400...415	1 0	AX25-30-10-26	1SBL931074R2610	0.340
								0 1	AX25-30-01-26	1SBL931074R2601	0.340
200	200...220			380...400	400...415	1 0	AX25-30-10-75	1SBL931074R7510	0.340		
						0 1	AX25-30-01-75	1SBL931074R7501	0.340		
380...400	400...415			1 0	AX25-30-10-85	1SBL931074R8510	0.340				
				0 1	AX25-30-01-85	1SBL931074R8501	0.340				

(1) For other voltage version see voltage code table.

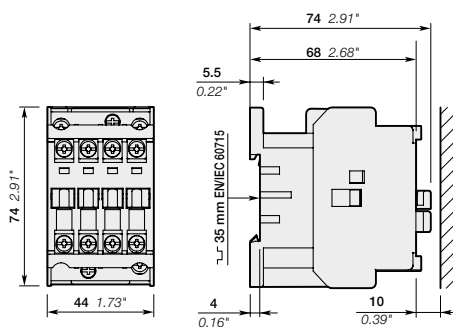

AX18

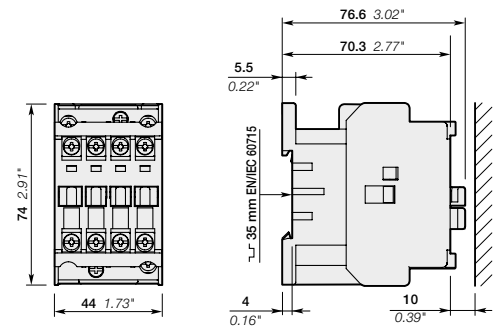

AX25

Main dimensions mm, inches

# AX32, AX40 3-pole contactors

## 15 to 18.5 kW

AC operated



AX32, AX40

AX32, AX40 contactors are mainly used for controlling 3-phase motors and power circuits up to 690 V AC.

These contactors are of the block type design with:

- 3 main poles and 1 built-in auxiliary contact
- control circuit: AC operated
- add-on auxiliary contact blocks for front or side mounting and a wide range of accessories.

IEC Rated operational power 400 V AC-3 kW	current $\theta \leq 40^\circ\text{C}$ AC-1 A	Rated control circuit voltage Uc (1)		Auxiliary contacts fitted 	Type	Order code	Weight (1 pce)  kg				
		V 50 Hz	V 60 Hz								
15	55	24	24	1 0	AX32-30-10-81	1SBL281074R8110	0.710				
				0 1	AX32-30-01-81	1SBL281074R8101	0.710				
		105	110...127	1 0	AX32-30-10-26	1SBL281074R2610	0.710				
				0 1	AX32-30-01-26	1SBL281074R2601	0.710				
		200	200...220	380...400	400...415	1 0	AX32-30-10-75	1SBL281074R7510	0.710		
						0 1	AX32-30-01-75	1SBL281074R7501	0.710		
		18.5	60	24	24	1 0	AX40-30-10-81	1SBL321074R8110	0.710		
						0 1	AX40-30-01-81	1SBL321074R8101	0.710		
105	110...127			200	200...220	380...400	400...415	1 0	AX40-30-10-26	1SBL321074R2610	0.710
								0 1	AX40-30-01-26	1SBL321074R2601	0.710
200	200...220			380...400	400...415	1 0	AX40-30-10-75	1SBL321074R7510	0.710		
						0 1	AX40-30-01-75	1SBL321074R7501	0.710		
380...400	400...415			1 0	AX40-30-10-85	1SBL321074R8510	0.710				
				0 1	AX40-30-01-85	1SBL321074R8501	0.710				

(1) For other voltage version see voltage code table.

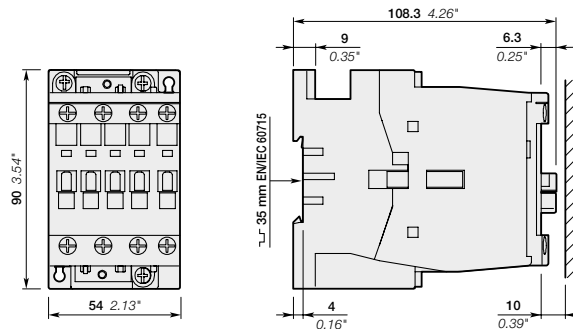

AX32, AX40

Main dimensions mm, inches



# AX50 ... AX80 3-pole contactors

## 22 to 37 kW

AC operated



AX50 ... AX80

1SBC10033V0014

AX50 ... AX80 contactors are mainly used for controlling 3-phase motors and power circuits up to 690 V AC.

These contactors are of the block type design with:

- 3 main poles
- control circuit: AC operated
- add-on auxiliary contact blocks for front or side mounting and a wide range of accessories.

Ordering details (without auxiliary block)

IEC Rated operational power 400 V AC-3 kW	current $\theta \leq 40^\circ\text{C}$ AC-1 A	Rated control circuit voltage Uc (1)		Auxiliary contacts fitted 	Type	Order code	Weight (1 pce)  kg
		V 50 Hz	V 60 Hz				
22	100	24	24	0 0	AX50-30-00-81	1SBL351074R8100	1.120
		105	110...127	0 0	AX50-30-00-26	1SBL351074R2600	1.120
		200	200...220	0 0	AX50-30-00-75	1SBL351074R7500	1.120
		380...400	400...415	0 0	AX50-30-00-85	1SBL351074R8500	1.120
30	115	24	24	0 0	AX65-30-00-81	1SBL371074R8100	1.120
		105	110...127	0 0	AX65-30-00-26	1SBL371074R2600	1.120
		200	200...220	0 0	AX65-30-00-75	1SBL371074R7500	1.120
		380...400	400...415	0 0	AX65-30-00-85	1SBL371074R8500	1.120
37	125	24	24	0 0	AX80-30-00-81	1SBL411074R8100	1.120
		105	110...127	0 0	AX80-30-00-26	1SBL411074R2600	1.120
		200	200...220	0 0	AX80-30-00-75	1SBL411074R7500	1.120
		380...400	400...415	0 0	AX80-30-00-85	1SBL411074R8500	1.120

(1) For other voltage version see voltage code table.

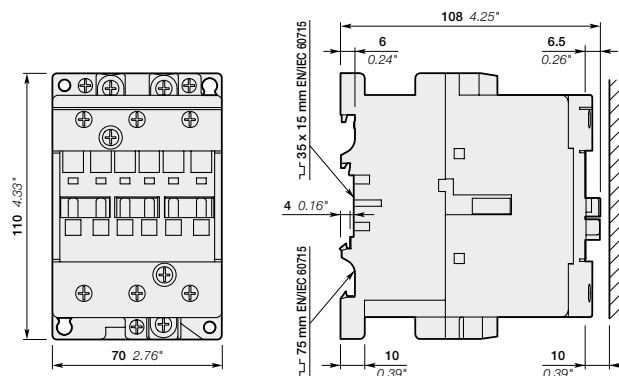

AX50, AX65, AX80

Main dimensions mm, inches

# AX50 ... AX80 3-pole contactors

## 22 to 37 kW

AC operated with 1 N.O. + 1 N.C. auxiliary contacts



AX50 ... AX80

AX50 ... AX80 contactors are mainly used for controlling 3-phase motors and power circuits up to 690 V AC.

These contactors are of the block type design with:

- 3 main poles and 1 side mounted auxiliary contact block
- control circuit: AC operated
- add-on auxiliary contact blocks for front or side mounting and a wide range of accessories.

IEC Rated operational power 400 V AC-3 kW	current $\theta \leq 40^\circ\text{C}$ AC-1 A	Rated control circuit voltage Uc (1)		Auxiliary contacts fitted 	Type	Order code	Weight (1 pce)  kg
		V 50 Hz	V 60 Hz				
22	100	24	24	1 1	AX50-30-11-81	1SBL351074R8111	1.160
		105	110...127	1 1	AX50-30-11-26	1SBL351074R2611	1.160
		200	200...220	1 1	AX50-30-11-75	1SBL351074R7511	1.160
		380...400	400...415	1 1	AX50-30-11-85	1SBL351074R8511	1.160
30	115	24	24	1 1	AX65-30-11-81	1SBL371074R8111	1.160
		105	110...127	1 1	AX65-30-11-26	1SBL371074R2611	1.160
		200	200...220	1 1	AX65-30-11-75	1SBL371074R7511	1.160
		380...400	400...415	1 1	AX65-30-11-85	1SBL371074R8511	1.160
37	125	24	24	1 1	AX80-30-11-81	1SBL411074R8111	1.160
		105	110...127	1 1	AX80-30-11-26	1SBL411074R2611	1.160
		200	200...220	1 1	AX80-30-11-75	1SBL411074R7511	1.160
		380...400	400...415	1 1	AX80-30-11-85	1SBL411074R8511	1.160

(1) For other voltage version see voltage code table.

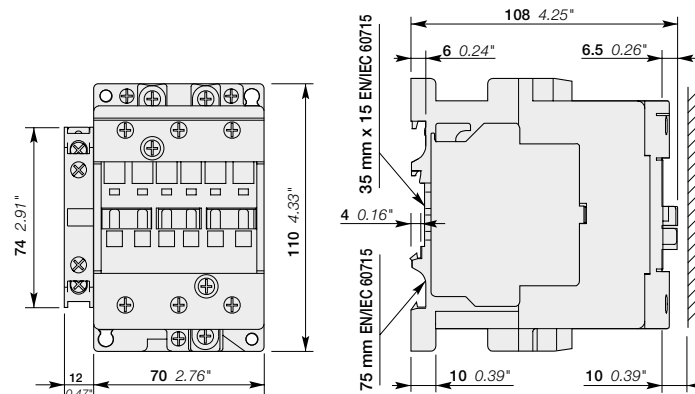

AX50, AX65, AX80

Main dimensions mm, inches

# AX95 ... AX150 3-pole contactors

## 45 to 75 kW

AC operated with 1 N.O. + 1 N.C. auxiliary contacts



AX95 ... AX150

1SFL01136V0001

AX95 ... AX150 contactors are mainly used for controlling 3-phase motors and power circuits up to 690 V AC.

These contactors are of the block type design with:

- 3 main poles and 1 side mounted auxiliary contact block
- control circuit: AC operated
- add-on auxiliary contact blocks for front or side mounting and a wide range of accessories.

IEC Rated operational power 400 V AC-3 kW	current $\theta \leq 40^\circ\text{C}$ AC-1 A	Rated control circuit voltage Uc (1)		Auxiliary contacts fitted 	Type	Order code	Weight (1 pce)  kg
		V 50 Hz	V 60 Hz				
45	145	24	24	1 1	AX95-30-11-81	1SFL431074R8111	2.08
		105	110...127	1 1	AX95-30-11-26	1SFL431074R2611	2.08
		200	200...220	1 1	AX95-30-11-75	1SFL431074R7511	2.08
		380...400	400...415	1 1	AX95-30-11-85	1SFL431074R8511	2.08
55	160	24	24	1 1	AX115-30-11-81	1SFL981074R8111	2.08
		105	110...127	1 1	AX115-30-11-26	1SFL981074R2611	2.08
		200	200...220	1 1	AX115-30-11-75	1SFL981074R7511	2.08
		380...400	400...415	1 1	AX115-30-11-85	1SFL981074R8511	2.08
75	190	24	24	1 1	AX150-30-11-81	1SFL991074R8111	2.08
		105	110...127	1 1	AX150-30-11-26	1SFL991074R2611	2.08
		200	200...220	1 1	AX150-30-11-75	1SFL991074R7511	2.08
		380...400	400...415	1 1	AX150-30-11-85	1SFL991074R8511	2.08

(1) For other voltage version see voltage code table.

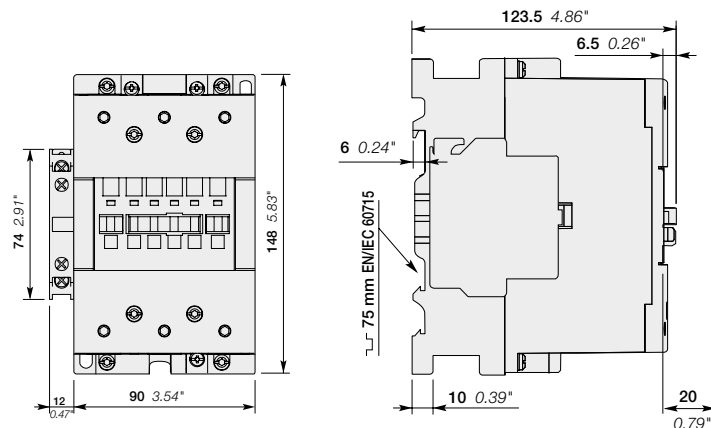

AX95, AX115, AX150

Main dimensions mm, inches

# AX09 ... AX150 3-pole contactors

## Main accessories

### Contactor and main accessories (other accessories available)

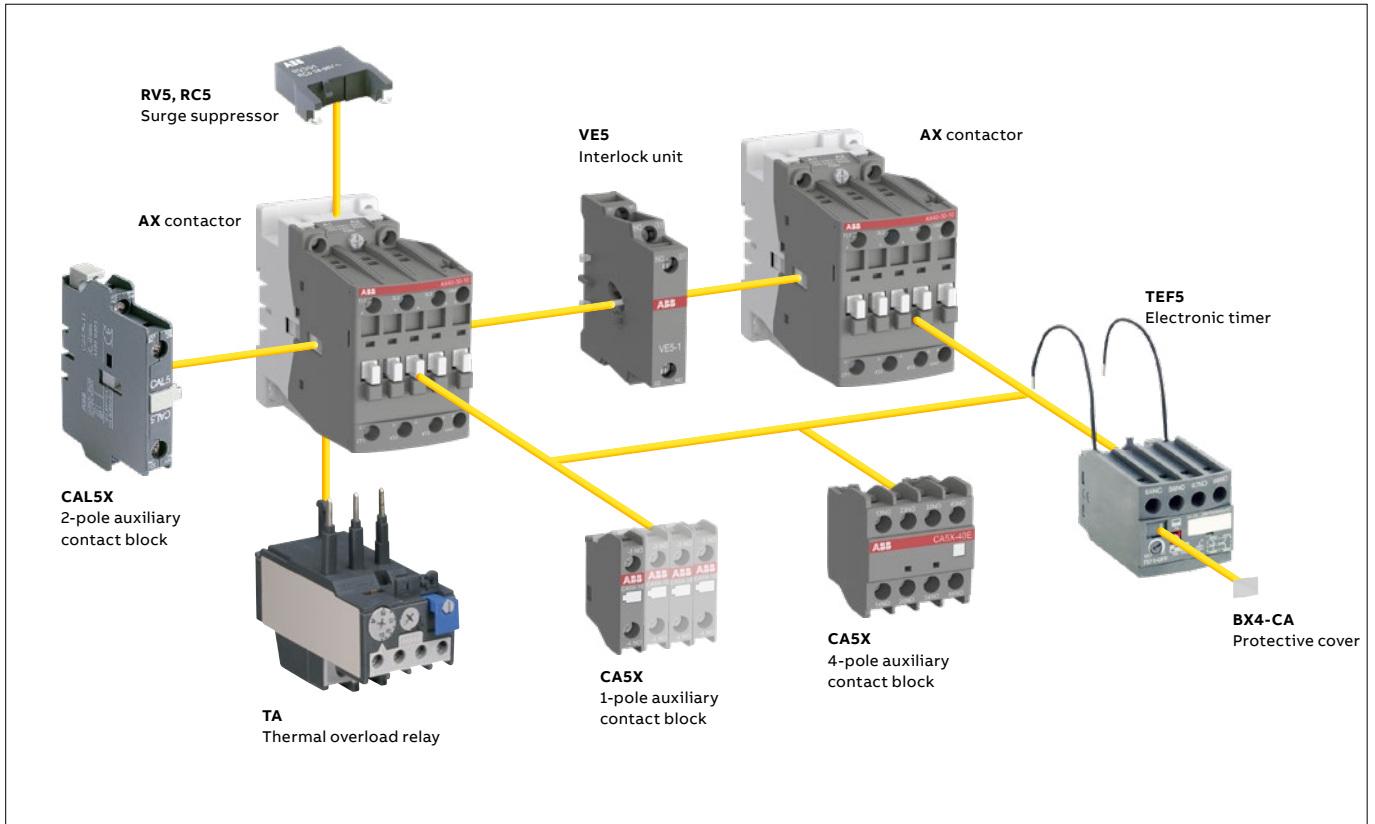

### Main accessory fitting details

Many configurations of accessories are possible depending on whether these are front-mounted or side-mounted.

Contactor types	Main poles	Built-in auxiliary contacts	Front-mounted accessories		Electronic timer	Side-mounted accessories	
			Auxiliary contact blocks			Auxiliary contact blocks	Interlock unit
			1-pole CA5X	4-pole CA5X	TEF5	2-pole CAL	VM5 or VE5
AX09 ... AX25	3 0 3 0	1 0 0 1 (1)	1 to 4 x CA5X 1 to 2 x CE5 max (2)	or 1 x CA5X (4-pole)	or 1 x TEF5	1 to 2 x CAL5X-11	or 1 x VM5-1 or VE5-1 +1 x CAL5X-11
AX32, AX40	3 0 3 0	1 0 0 1 (1)	1 to 5 x CA5X 1 to 3 x CE5 max (3)	or 1 x CA5X (4-pole) + 1 x 1-pole CA5X or CE5 (3)	or 1 x TEF5 + 1 x CA5X (1-pole)	1 to 2 x CAL5X-11	or 1 x VM5-1 or VE5-1 +1 x CAL5X-11
AX50 ... AX80	3 0	0 0	1 to 6 x CA5X 1 to 5 x CE5 max (4)	or 1 x CA5X (4-pole) + 2 x 1-pole CA5X or CE5 (4)	or 1 x TEF5 + 2 x CA5X (1-pole)	2 x CAL5X-11	or 1 x VE5-2
AX50 ... AX80	3 0	1 1	1 to 6 x CA5X 1 to 5 x CE5 max (4)	or 1 x CA5X (4-pole) + 2 x 1-pole CA5X or CE5 (4)	or 1 x TEF5 + 2 x CA5X (1-pole)	1 x CAL5X-11	or 1 x VE5-2
AX95 ... AX150	3 0	1 1	1 to 6 x CA5X	or 1 x CA5X (4-pole) + 2 x 1-pole CA5X	-	1 x CAL18X-11	or 1 x VE5-2

(1) 2 N.C. CA5X auxiliary contacts maximum in mounting position 5. for mounting position refer technical data page.  
 (2) The total number of N.O. or N.C. CE5 and other N.C. CA5X is limited to 2. CE5 not allowed in mounting position 5.  
 (3) The total number of N.O. or N.C. CE5 and other N.C. CA5X is limited to 3. CE5 not allowed in mounting position 5.  
 (4) The total number of N.O. or N.C. CE5 and other N.C. CA5X is limited to 5. CE5 not allowed in mounting position 5.

### Overload relays fitting details (1)

Contactor types	Thermal overload relays
AX09 ... AX25	TA25DU-M (0.1...32 A)
AX32, AX40	TA25DU-M (0.1...32 A) or TA42DU-M (18...42 A)
AX50 ... AX80	TA75DU-M (18...80 A)
AX95 ... AX150	TA80DU-M (29...80 A) or TA110DU-M (66...110 A)

The addition of a thermal overload relay on the contactor does not prevent fitting of many other accessories as shown above.

(1) Direct mounting - No kit required.

# AX09 ... AX150 3-pole contactors

## Main accessories



CA5X-10



CA5X-4P



CAL5X-11



VE5-1

For contactors	Auxiliary contacts	Type	Order code	Pkg qty	Weight (1 pce)
					kg

### Front-mounted instantaneous auxiliary contact blocks

AX09 ... AX150 and NX 4-pole	1 -	CA5X-10	1SBN019010R1010	10	0.014
	- 1	CA5X-01	1SBN019010R1001	10	0.014
AX50 ... AX150	2 2	CA5X-22E	1SBN019040R1022	2	0.060
AX09 ... AX40-30-10	2 2	CA5X-22M	1SBN019040R1122	2	0.060

### Side-mounted instantaneous auxiliary contact block, 2 poles

AX09 ... AX80 and NX - 4 pole	1 1	CAL5X-11	1SBN019020R1011	2	0.050
AX95 ... AX150 (1)	1 1	CAL18X-11	1SFN019820R1011	2	0.050

### Mechanical interlock units for two horizontal mounted contactors (2)

Left side contactor	Right side contactor	Mounting					
AX09 ... AX40	AX09 ... AX40	Mech.	- -	VM5-1	1SBN030100R1000	1	0.066

### Mechanical and electrical interlock units for two horizontal mounted contactors

Left side contactor	Right side contactor	Mounting					
AX09 ... AX40	AX09 ... AX40	Mech. + Elect.	- 2	VE5-1	1SBN030110R1000	1	0.076
AX32 ... AX80	AX50 ... AX80	Mech. + Elect.	- 2	VE5-2	1SBN030210R1000	1	0.146
AX50 ... AX80	AX32 ... AX80	Mech. + Elect.	- 2	VE5-2	1SBN030210R1000	1	0.146
AX50 ... AX80	AX95 ... AX150	Mech. + Elect.	- 2	VE5-2 (3)	1SBN030210R1000	1	0.146
AX95 ... AX150	AX50 ... AX80	Mech. + Elect.	- 2	VE5-2 (3)	1SBN030210R1000	1	0.146
AX95 ... AX150	AX95 ... AX150	Mech. + Elect.	- 2	VE5-2	1SBN030210R1000	1	0.146

(1) See "Main accessory fitting details".

(2) Mechanical durability: VM5-1 = 5 millions cycles, VM300H = 1 million cycles.

(3) The combination of AX50 ... AX80 contactors interlocked with AX95 ... AX150 contactors cannot be mounted on symmetrical rail (75 mm, IEC/EN 60715).

## AX09 ... AX150 3-pole contactors

### Main accessories



1SBC101396F0014

TEF5-OFF

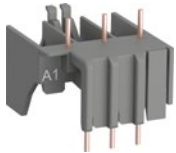

1SBC592813F0301

BEA



1SBC574001F0301

RV5/50



1SBC565483F0301

WB75-A

For contactors	Time delay range selected by switch	Delay type	Auxiliary contacts	Type	Order code	Pkg qty	Weight (1 pce)
							kg

#### Electronic timers

AX09 ... AX80	0.1...1 s	ON-delay	1 1	TEF5-ON	1SBN020312R1000	1	0.065
NX 4 pole	1...10 s	OFF-delay	1 1	TEF5-OFF	1SBN020314R1000	1	0.065
	10...100 s						

Note: Rated control circuit voltage Uc 24...240 V 50/60 Hz or DC.

For contactors	MMS type	Type	Order code	Pkg qty	Weight (1 pce)
					kg

#### Connecting links with manual motor starters

AX09 ... AX16	MS116-0.16 ... MS116-16	BEA16/116	1SBN081406R1000	10	0.020
AX25	MS116-0.16 ... MS116-16	BEA25/116	1SBN089306T1000	10	0.020
AX25	MS116-20 ... MS116-32	BEA25/132	1SBN089306T1001	10	0.020

For contactors	Rated control circuit voltage Uc	Type	Order code	Pkg qty	Weight (1 pce)
	V AC				kg

#### Surge suppressors

AX09 ... AX150	24...50	RV5/50	1SBN050010R1000	2	0.015
	50...133	RV5/133	1SBN050010R1001	2	0.015
	110...250	RV5/250	1SBN050010R1002	2	0.015
	250...440	RV5/440	1SBN050010R1003	2	0.015
AX09 ... AX40	24...50	RC5-1/50	1SBN050100R1000	2	0.012
	50...133	RC5-1/133	1SBN050100R1001	2	0.012
	110...250	RC5-1/250	1SBN050100R1002	2	0.012
	250...440	RC5-1/440	1SBN050100R1003	2	0.012
AX50 ... AX150	24...50	RC5-2/50	1SBN050200R1000	2	0.015
	50...133	RC5-2/133	1SBN050200R1001	2	0.015
	110...250	RC5-2/250	1SBN050200R1002	2	0.015
	250...440	RC5-2/440	1SBN050200R1003	2	0.015

For contactors	Rated control circuit voltage Uc		Type	Order code	Pkg qty	Weight (1 pce)
	50Hz	60 Hz				kg

#### Mechanical latching units



AX09 ... AX80	24	24...28	WB75-A	FPTN372726R1001	1	0.120
	220...230	220...255	WB75-A	FPTN372726R1006	1	0.120

(1) See "Main accessory fitting details".

## AX06 ... AX40 3-pole contactors

### Technical data

#### Main pole - Utilization characteristics according to IEC

Contactor types	AC operated	AX09	AX12	AX18	AX25	AX32	AX40
Standards		IEC 60947-1 / 60947-4-1 and EN 60947-1 / 60947-4-1					
Rated operational voltage U <sub>e</sub> max.		690 V					
Rated frequency (without derating)		50 / 60 Hz					
Conventional free-air thermal current I <sub>th</sub> acc. to IEC 60947-4-1, open contactors, $\theta \leq 40^\circ\text{C}$		24 A	26 A	28 A	32 A	65 A	65 A
With conductor cross-sectional area		4 mm <sup>2</sup>	4 mm <sup>2</sup>	4 mm <sup>2</sup>	6 mm <sup>2</sup>	16 mm <sup>2</sup>	16 mm <sup>2</sup>
AC-1 Utilization category							
For air temperature close to contactor							
I <sub>e</sub> / Rated operational current AC-1	$\theta \leq 40^\circ\text{C}$	22 A	25 A	27 A	32 A	55 A	60 A
U <sub>e</sub> max. $\leq 690\text{ V}, 50/60\text{ Hz}$	$\theta \leq 55^\circ\text{C}$	22 A	22 A	25 A	27 A	55 A	60 A
	$\theta \leq 70^\circ\text{C}$	18 A	18 A	20 A	23 A	39 A	42 A
With conductor cross-sectional area		2.5 mm <sup>2</sup>	2.5 mm <sup>2</sup>	4 mm <sup>2</sup>	6 mm <sup>2</sup>	10 mm <sup>2</sup>	16 mm <sup>2</sup>
AC-3 Utilization category							
For air temperature close to contactor $\theta \leq 55^\circ\text{C}$							
I <sub>e</sub> / Max. rated operational current AC-3 (1)							
 3-phase motors	220-230-240 V	9 A	12 A	18 A	25 A	32 A	40 A
	380-400 V	9 A	12 A	18 A	25 A	32 A	40 A
	415 V	9 A	12 A	18 A	25 A	32 A	40 A
	440 V	9 A	9 A	12 A	16 A	32 A	37 A
	500 V	9 A	9 A	12 A	14 A	28 A	33 A
	690 V	7 A	7 A	9 A	10 A	21 A	25 A
Rated operational power AC-3 (1)							
 1500 r.p.m. 50 Hz 1800 r.p.m. 60 Hz 3-phase motors	220-230-240 V	2.2 kW	3 kW	4 kW	6.5 kW	9 kW	11 kW
	380-400 V	4 kW	5.5 kW	7.5 kW	11 kW	15 kW	18.5 kW
	415 V	4 kW	5.5 kW	9 kW	11 kW	15 kW	18.5 kW
	440 V	4 kW	4 kW	5.5 kW	9 kW	18.5 kW	22 kW
	500 V	5.5 kW	5.5 kW	7.5 kW	9 kW	18.5 kW	22 kW
	690 V	5.5 kW	5.5 kW	7.5 kW	9 kW	18.5 kW	22 kW
Rated making capacity AC-3		10 x I <sub>e</sub> AC-3 acc. to IEC 60947-4-1					
Rated breaking capacity AC-3		8 x I <sub>e</sub> AC-3 acc. to IEC 60947-4-1					
AC-8a Utilization category (without thermal overload relay - U <sub>e</sub> 400 V 50/60 Hz - $\theta \leq 40^\circ\text{C}$ )							
I <sub>e</sub> / Rated operational current AC-8a		12 A	16 A	22 A	30 A	40 A	50 A
Rated operational power AC-8a		5.5 kW	7.5 kW	11 kW	15 kW	20 kW	25 kW
Short-circuit protection device for contactors without thermal overload relay - Motor protection excluded (2)							
U <sub>e</sub> $\leq 500\text{ V AC}$ - gG type fuse		25 A	25 A	32 A	32 A	63 A	63 A
Rated short-time withstand current I <sub>cw</sub> at 40 °C ambient temperature, in free air from a cold state	1 s	250 A	280 A	300 A	300 A	600 A	600 A
	10 s	100 A	120 A	145 A	200 A	400 A	400 A
	30 s	60 A	70 A	80 A	105 A	225 A	225 A
	1 min	50 A	55 A	60 A	85 A	150 A	150 A
	15 min	26 A	26 A	28 A	32 A	65 A	65 A
Maximum breaking capacity cos $\phi = 0.45$	at 440 V	250 A	250 A	250 A	250 A	820 A	820 A
	at 690 V	90 A	90 A	90 A	90 A	340 A	340 A
Power dissipation per pole	I <sub>e</sub> / AC-1	0.8 W	0.8 W	1 W	1.2 W	2.5 W	3 W
	I <sub>e</sub> / AC-3	0.1 W	0.1 W	0.2 W	0.35 W	0.9 W	1.3 W
Max. electrical switching frequency	AC-1	600 cycle/h					
	AC-3	1200 cycle/h					
Mechanical durability							
Number of operating cycles		10 millions operating cycles					
Max. switching frequency		3600 cycles/h					



(1) For the corresponding kW/A values of 1500 r.p.m, 50 Hz or 1800 r.p.m, 60 Hz, 3-phase motors, see "Motor rated operational powers and currents".

(2) For the protection of motor starters against short circuits, see "Coordination with short-circuit protection devices".

## AX50 ... AX150 3-pole contactors

### Technical data

#### Main pole - Utilization characteristics according to IEC

Contactor types	AC operated	AX50	AX65	AX80	AX95	AX115	AX150
Standards		IEC 60947-1 / 60947-4-1 and EN 60947-1 / 60947-4-1					
Rated operational voltage U <sub>e</sub> max.		690 V				1000 V	
Rated frequency (without derating)		50 / 60 Hz					
Conventional free-air thermal current I <sub>th</sub> acc. to IEC 60947-4-1, open contactors, $\theta \leq 40^\circ\text{C}$		100 A	125 A	125 A	145 A	160 A	190 A
With conductor cross-sectional area		35 mm <sup>2</sup>	50 mm <sup>2</sup>	50 mm <sup>2</sup>	50 mm <sup>2</sup>	70 mm <sup>2</sup>	95 mm <sup>2</sup>
AC-1 Utilization category							
For air temperature close to contactor							
I <sub>e</sub> / Rated operational current AC-1	$\theta \leq 40^\circ\text{C}$	100 A	115 A	125 A	145 A	160 A	190 A
U <sub>e</sub> max. $\leq 690\text{ V}, 50/60\text{ Hz}$	$\theta \leq 55^\circ\text{C}$	85 A	95 A	105 A	135 A	145 A	145 A
	$\theta \leq 70^\circ\text{C}$	70 A	80 A	85 A	115 A	130 A	130 A
With conductor cross-sectional area		35 mm <sup>2</sup>	50 mm <sup>2</sup>	50 mm <sup>2</sup>	50 mm <sup>2</sup>	70 mm <sup>2</sup>	95 mm <sup>2</sup>
AC-3 Utilization category							
For air temperature close to contactor $\theta \leq 55^\circ\text{C}$							
I <sub>e</sub> / Max. rated operational current AC-3 (1)							
 3-phase motors	220-230-240 V	53 A	65 A	80 A	96 A	115 A	150 A
	380-400 V	50 A	65 A	80 A	96 A	115 A	150 A
	415 V	50 A	65 A	80 A	96 A	115 A	150 A
	440 V	45 A	65 A	70 A	93 A	100 A	100 A
	500 V	45 A	55 A	65 A	80 A	100 A	100 A
	690 V	35 A	43 A	46 A	65 A	82 A	82 A
Rated operational power AC-3 (1)							
 1500 r.p.m. 50 Hz 1800 r.p.m. 60 Hz 3-phase motors	220-230-240 V	15 kW	18.5 kW	22 kW	25 kW	30 kW	45 kW
	380-400 V	22 kW	30 kW	37 kW	45 kW	55 kW	75 kW
	415 V	25 kW	37 kW	40 kW	55 kW	59 kW	75 kW
	440 V	25 kW	37 kW	40 kW	55 kW	59 kW	59 kW
	500 V	30 kW	37 kW	45 kW	55 kW	59 kW	59 kW
	690 V	30 kW	37 kW	40 kW	55 kW	75 kW	75 kW
Rated making capacity AC-3		10 x I <sub>e</sub> AC-3 acc. to IEC 60947-4-1					
Rated breaking capacity AC-3		8 x I <sub>e</sub> AC-3 acc. to IEC 60947-4-1					
AC-8a Utilization category (without thermal overload relay - U <sub>e</sub> 400 V 50/60 Hz - $\theta \leq 40^\circ\text{C}$ )							
I <sub>e</sub> / Rated operational current AC-8a		63 A	85 A	95 A	120 A	140 A	-
Rated operational power AC-8a		30 kW	45 kW	50 kW	59 kW	75 kW	-
Short-circuit protection device for contactors without thermal overload relay - Motor protection excluded (2)							
U <sub>e</sub> $\leq 500\text{ V AC}$ - gG type fuse		100 A	125 A	160 A	160 A	200 A	315 A
Rated short-time withstand current I <sub>cw</sub> at 40 °C ambient temperature, in free air from a cold state	1 s	1000 A	1000 A	1000 A	1320 A	1320 A	1320 A
	10 s	650 A	650 A	650 A	800 A	800 A	800 A
	30 s	370 A	370 A	370 A	500 A	500 A	500 A
	1 min	250 A	250 A	250 A	350 A	350 A	350 A
	15 min	110 A	135 A	135 A	160 A	160 A	175 A
Maximum breaking capacity cos $\phi = 0.45$							
	at 440 V	1300 A	1300 A	1300 A	1160 A	1160 A	1160 A
	at 690 V	630 A	630 A	630 A	800 A	800 A	800 A
Power dissipation per pole	I <sub>e</sub> / AC-1	5 W	6.5 W	7 W	6.5 W	7.5 W	10.5 W
	I <sub>e</sub> / AC-3	1.3 W	1.5 W	2.3 W	2.7 W	3.9 W	6.5 W
Max. electrical switching frequency	AC-1	600 cycle/h			300 cycles/h		
	AC-3	600 cycle/h			300 cycles/h		
Mechanical durability							
Number of operating cycles		10 millions operating cycles					
Max. switching frequency		3600 cycles/h					

(1) For the corresponding kW/A values of 1500 r.p.m. 50 Hz or 1800 r.p.m. 60 Hz, 3-phase motors, see "Motor rated operational powers and currents".

(2) For the protection of motor starters against short circuits, see "Coordination with short-circuit protection devices".





## AX50 ... AX150 3-pole contactors

### Technical data

#### Main pole - Utilization characteristics according to UL / NEMA / CSA

Contactor types	AC operated	AX50	AX65	AX80	AX95	AX115	AX150
Standards		UL 60947-4-1, CSA C22.2 NO. 60947-4-1-07			UL 508, CSA C22.2 N°14, UL 60947-1 / 60947-4-1A and CSA 60947-1 / 60947-4-1A		
Maximum operational voltage		600 V					
UL / CSA general use rating							
600 V AC		80 A	90 A	105 A	150 A	150 A	170 A
With conductor cross-sectional area		AWG 4	AWG 3	AWG 2	AWG 1	AWG 1/0	AWG 2/0
UL / CSA maximum 1-phase motor rating							
Full load current	120 V AC	34 A	56 A	80 A	-	-	-
	240 V AC	50 A	50 A	68 A	-	-	-
Horse power rating	120 V AC	3 hp	5 hp	7-1/2 hp	-	-	-
	240 V AC	10 hp	10 hp	15 hp	-	-	-
UL / CSA maximum 3-phase motor rating							
Full load current (1)	200-208 V AC	48.3 A	62.1 A	78.2 A	92 A	92 A	120 A
	220-240 V AC	54 A	68 A	80 A	80 A	104 A	130 A
	440-480 V AC	52 A	77 A	77 A	77 A	96 A	124 A
	550-600 V AC	52 A	77 A	77 A	77 A	99 A	125 A
Horse power rating (1)	200-208 V AC	15 hp	20 hp	25 hp	30 hp	30 hp	40 hp
	220-240 V AC	20 hp	25 hp	30 hp	30 hp	40 hp	50 hp
	440-480 V AC	40 hp	60 hp	60 hp	60 hp	75 hp	100 hp
	550-600 V AC	50 hp	75 hp	75 hp	75 hp	100 hp	125 hp
Short-circuit protection device for contactors without thermal overload relay - Motor protection excluded							
High fault current		100 kA	100 kA	100 kA	100 kA	100 kA	100 kA
Fuse rating		100 A	200 A	200 A	200 A	200 A	(2)
Fuse type, 600 V		J	J	J	J	J	(2)
Maximum electrical switching frequency							
For general use		600 cycles/h			300 cycles/h		
For motor use		600 cycles/h			300 cycles/h		

(1) For the corresponding kW/A or hp/A values of 1500 r.p.m, 50 Hz or 1800 r.p.m, 60 Hz, 3-phase motors, see "Motor rated operational powers and currents".

(2) In preparation.

# AX09 ... AX40 3-pole contactors

## Technical data

### General technical data

Contactor types	AC operated	AX09	AX12	AX18	AX25	AX32	AX40
Rated insulation voltage Ui acc. to IS / IEC 60947-4-1		690 V					
acc. to UL / CSA		600 V					
Rated impulse withstand voltage Uimp.		6 kV					
Ambient air temperature close to contactor							
Operation	Fitted with thermal overload relay	-25...+55 °C (1)					
	Without thermal overload relay	-40...+70 °C					
Storage		-60...+80 °C					
Climatic withstand		acc. to IEC 60068-2-30 and 60068-2-11 - UTE C 63-100 specification II					
Maximum operating altitude (without derating)		3000 m					
Shock withstand acc. to IEC 60068-2-27 and EN 60068-2-27							
Mounting position 1							
	Shock direction	1/2 sinusoidal shock for 11 ms: no change in contact position, closed or open position					
	A	20 g					
	B1	10 g closed position / 5 g open position					
	B2	15 g					
	C1	20 g					
	C2	20 g					

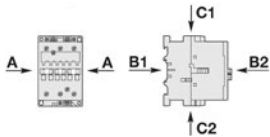

(1) The max. operational current is 23 A for AX25 with TA25DU-25M.

### Magnet system characteristics

Contactor types	AC operated	AX09	AX12	AX18	AX25	AX32	AX40
Coil operating limits acc. to IS / IEC 60947-4-1	AC supply	at $\theta \leq 55\text{ °C}$ 0.85...1.1 x Uc					
AC control voltage 50/60 Hz		Please also refer to "Mounting characteristics and conditions for use"					
Rated control circuit voltage Uc	at 50 Hz	24...440 V					
	at 60 Hz	24...440 V					
Coil consumption	Average pull-in value	50 Hz	70 VA			120 VA	
		60 Hz	80 VA			140 VA	
		50/60 Hz (1)	74 VA / 70 VA			125 VA / 120 VA	
Average holding value		50 Hz	8 VA / 2 W			12 VA / 3 W	
		60 Hz	8 VA / 2 W			12 VA / 3 W	
		50/60 Hz (1)	8 VA / 2 W			12 VA / 3 W	
Drop-out voltage		approx. 40...65 % of Uc					
Operating time							
Between coil energization and:	N.O. contact closing	10...26 ms				8...21 ms	
	N.C. contact opening	7...21 ms				6...18 ms	
Between coil de-energization and:	N.O. contact opening	4...15 ms				4...11 ms	
	N.C. contact closing	9...20 ms				7...14 ms	

(1) 50/60 Hz coils: see "Coil voltage code table".

### Mounting characteristics and conditions for use

Contactor types	AC operated	AX09	AX12	AX18	AX25	AX32	AX40
Mounting positions							
Control voltage / Ambient temperature		Max. N.O. or N.C. built-in and add-on N.O. or N.C. auxiliary contacts: see accessory fitting details for 3-pole contactor AX09 ... AX80					
Mounting positions 1, 1±30°, 2, 3, 4, 5	at $\theta \leq 55\text{ °C}$	0.85...1.1 x Uc					
	at $55\text{ °C} < \theta \leq 70\text{ °C}$	Uc					
6	at $\theta \leq 55\text{ °C}$	0.95...1.1 x Uc					
	at $\theta > 55\text{ °C}$	Unauthorized					
Mounting distances		The contactors can be assembled side by side					
Fixing							
On rail according to IEC 60715, EN 60715		35 x 7.5 mm or 35 x 15 mm					
By screws (not supplied)		2 x M4 screws placed diagonally					

# AX50 ... AX150 3-pole contactors

## Technical data

### General technical data

Contactor types	AC operated	AX50	AX65	AX80	AX95	AX115	AX150
Rated insulation voltage Ui acc. to IEC 60947-4-1		690 V			1000 V		
acc. to UL / CSA		600 V			-		
Rated impulse withstand voltage Uimp.		6 kV			8 kV		
Ambient air temperature close to contactor							
Operation	Fitted with thermal overload relay	-25...+55 °C (1)					
	Without thermal overload relay	-40...+70 °C					
Storage		-60...+80 °C				-40 to +70 °C	
Climatic withstand		acc. to IEC 60068-2-30 and 60068-2-11 - UTE C 63-100 specification II				acc. to IEC 60068-2-30	
Maximum operating altitude (without derating)		3000 m					
Shock withstand acc. to IEC 60068-2-27 and EN 60068-2-27							
Mounting position 1							
	Shock direction	1/2 sinusoidal shock for 11 ms: no change in contact position, closed or open position (2)					
	A	20 g					
	B1	10 g closed position / 5 g open position					
	B2	15 g					
	C1	20 g					
	C2	20 g					

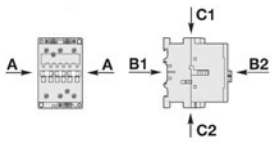

(1) The max. operational current is 74A for AX80 with TA75DU-80M.  
 (2) These values are not valid for rail mounting with contactors AX95 ... AX150.

### Magnet system characteristics

Contactor types	AC operated	AX50	AX65	AX80	AX95	AX115	AX150
Coil operating limits acc. to IEC 60947-4-1	AC supply	at $\theta \leq 55^\circ\text{C}$ 0.85...1.1 x Uc			At $\theta \leq 70^\circ\text{C}$ 0.85 ... 1.1 x Uc		
		Please also refer to "Mounting characteristics and conditions for use"					
AC control voltage 50/60 Hz							
Rated control circuit voltage Uc	at 50 Hz	24...440 V					
	at 60 Hz	24...440 V					
Coil consumption	Average pull-in value	50 Hz	180 VA			350 VA	
		60 Hz	210 VA			450 VA	
		50/60 Hz (1)	190 VA / 180 VA			410 VA / 365 VA	
	Average holding value	50 Hz	18 VA / 5.5 W			22 VA / 6.5 W	
		60 Hz	18 VA / 5.5 W			26 VA / 8 W	
		50/60 Hz (1)	18 VA / 5.5 W			27 VA / 7.5 W	
Drop-out voltage		approx. 40...65 % of Uc					
Operating time							
Between coil energization and:	N.O. contact closing	8...27 ms			10...25 ms		
	N.C. contact opening	7...22 ms			7...22 ms		
Between coil de-energization and:	N.O. contact opening	4...11 ms			7...15 ms		
	N.C. contact closing	7...14 ms			10...18 ms		

(1) 50/60 Hz coils: see "Coil voltage code table".











### Mounting characteristics and conditions for use

Contactor types	AC operated	AX50	AX65	AX80	AX95	AX115	AX150
Mounting positions							
		Add on max. N.O. or N.C. auxiliary contacts: see accessory fitting details for 3-pole contactor AX50 ... AX150					
Control voltage / Ambient temperature	Mounting positions 1, 1±30°, 2, 3, 4, 5	at $\theta \leq 55^\circ\text{C}$			0.85...1.1 x Uc		
		at $55^\circ\text{C} \leq \theta \leq 70^\circ\text{C}$			Uc		
	6	at $\theta \leq 55^\circ\text{C}$			0.95...1.1 x Uc		
		at $\theta \leq 55^\circ\text{C}$			Unauthorized		
Mounting distances		The contactors can be assembled side by side					
Fixing							
	On rail according to IEC 60715, EN 60715	35 x 15 mm or 75 x 25 mm				-	
	By screws (not supplied)	2 x M6 screws placed diagonally				2 x M6 screws placed diagonally	

# AX09 ... AX40 3-pole contactors

## Technical data















### Connecting characteristics

Contactor types	AC operated	AX09	AX12	AX18	AX25	AX32	AX40
Main terminals		 Screw terminals with cable clamp				 Screw terminals with double connector 2 x (5.6 x 6.5 mm)	
Connection capacity (min. ... max.)							
Main conductors (poles)							
 Rigid	Solid ( $\leq 4 \text{ mm}^2$ )	} 1 x	1...4 mm <sup>2</sup>			1...6 mm <sup>2</sup>	2.5...16 mm <sup>2</sup>
 Stranded ( $\geq 6 \text{ mm}^2$ )			2 x	1...4 mm <sup>2</sup>			1...6 mm <sup>2</sup>
 Flexible with non insulated ferrule		1 x	0.75...2.5 mm <sup>2</sup>			0.75...4 mm <sup>2</sup>	2.5...10 mm <sup>2</sup>
 Flexible with insulated ferrule		1 x	-			0.75...4 mm <sup>2</sup>	2.5...10 mm <sup>2</sup>
 Bars or lugs		2 x	-			0.75...2.5 mm <sup>2</sup>	2.5...10 mm <sup>2</sup>
		L <	7.7 mm			9.6 mm	-
		I >	3.7 mm			3.7 mm	-
Connection capacity acc. to UL/CSA	1 or 2 x	AWG 8...1				AWG 16...10	AWG 8...4
Stripping length		10 mm					14 mm
Tightening torque		1 Nm / 9 lb.in				1.2 Nm / 11 lb.in	2.3 Nm / 20 lb.in
Auxiliary conductors (built-in auxiliary terminals + coil terminals)							
 Rigid solid		1 x	1...4 mm <sup>2</sup>				
		2 x	1...4 mm <sup>2</sup>				
 Flexible with non insulated ferrule		1 x	0.75...2.5 mm <sup>2</sup>				
		2 x	0.75...2.5 mm <sup>2</sup>				
 Lugs		L <	7.7 mm			8 mm	
		I >	3.7 mm			3.7 mm	
Connection capacity acc. to UL/CSA	1 or 2 x	AWG 18...14					
Stripping length		10 mm					
Tightening torque							
Coil terminals		1 Nm / 9 lb.in					
Built-in auxiliary terminals		1 Nm / 9 lb.in					
Degree of protection acc. to IEC 60947-1 / EN 60947-1 and IEC 60529							
Main terminals		IP20 (only front side)					
Coil terminals		IP20				IP20	
Built-in auxiliary terminals		IP20 (only front side)				IP20	
Screw terminals		Delivered in open position, screws of unused terminals must be tightened					
Main terminals		M3.5				M5	
	Screwdriver type	Flat Ø 5.5 / Pozidriv 2				Flat Ø 6.5 / Pozidriv 2	
Coil terminals		M3.5					
	Screwdriver type	Flat Ø 5.5 / Pozidriv 2					
Built-in auxiliary terminals		M3.5					
	Screwdriver type	Flat Ø 5.5 / Pozidriv 2					

## AX50 ... AX150 3-pole contactors

### Technical data

#### Connecting characteristics

Contactor types	AC operated	AX50	AX65	AX80	AX95	AX115	AX150
Main terminals		 Screw terminals with single connector (13 x 10 mm)			 Screw terminals with single connector (14 x 14 mm)		
Connection capacity (min. ... max.)							
Main conductors (poles)							
	Rigid Solid ( $\leq 4 \text{ mm}^2$ )	} 1 x	6...50 mm <sup>2</sup>			10...95 mm <sup>2</sup>	
	Stranded ( $\geq 6 \text{ mm}^2$ )		2 x	6...25 mm <sup>2</sup>			6...35 mm <sup>2</sup>
	Flexible with ferrule	1 x	6...35 mm <sup>2</sup>			10...70 mm <sup>2</sup> (1)	
		2 x	6...16 mm <sup>2</sup>			6...35 mm <sup>2</sup> (1)	
	Flexible with insulated ferrule	1 x	6...35 mm <sup>2</sup>			10...70 mm <sup>2</sup> (1)	
		2 x	6...16 mm <sup>2</sup>			6...35 mm <sup>2</sup> (1)	
	Bars or lugs	L <	-			30 mm (2)	
		l >	-			6 mm	
Connection capacity acc. to UL / CSA		AWG 8 ... 1			AWG 6 ... 2/0		
Stripping length		16 mm			9 mm		
Tightening torque		Recommended		4.00 Nm / 35 lb.in		8 Nm / 71 lb.in	
		Max.		4.50 Nm		9 Nm	
Auxiliary conductors (built-in auxiliary terminals + coil terminals)							
	Rigid solid	1 x	1...4 mm <sup>2</sup>			0.75...2.5 mm <sup>2</sup>	
		2 x	1...4 mm <sup>2</sup>			0.75...2.5 mm <sup>2</sup>	
	Flexible with ferrule	1 x	1...2.5 mm <sup>2</sup>			0.75...2.5 mm <sup>2</sup>	
		2 x	0.75...2.5 mm <sup>2</sup>			0.75...2.5 mm <sup>2</sup>	
	Lugs	L <	8 mm <sup>2</sup>				
		l >	3.7 mm <sup>2</sup>				
Connection capacity acc. to UL / CSA		1 or 2x	AWG 18 ... 14		AWG 18 ... 14		
Stripping length							
Coil terminals		9 mm			9 mm		
Built-in auxiliary terminals		10 mm					
Tightening torque							
Coil terminals		Recommended		1 Nm / 9 lb.in			
		Max.		1.2 Nm			
Built-in auxiliary terminals		Recommended		-			
		Max.		-			
Degree of protection							
acc. to IEC 60947-1 / EN 60947-1 and IEC 60529							
Main terminals		IP10					
Coil terminals		IP20					
Built-in auxiliary terminals		-					
Screw terminals		Delivered in open position, screws of unused terminals must be tightened					
Main terminals		Screwdriver type			M6	M8	
					Flat Ø 6.5 / Pozidriv 2	Hexagon socket (s = 4 mm)	
Coil terminals		Screwdriver type			M3.5		
					Flat Ø 5.5 / Pozidriv 2		
Built-in auxiliary terminals		Screwdriver type			-		
					-		

(1) AX95 - AX150: use flexible without ferrule.

(2) With LW110 enlargement piece, see "Accessories".

## AX09 ... AX40 3-pole contactors

### Technical data

#### Built-in auxiliary contacts according to IEC - Other auxiliary contacts see "Accessories"

Contactor types	AC operated	AX09	AX12	AX18	AX25	AX32	AX40
Rated operational voltage U <sub>e</sub> max.		690 V					
Rated frequency (without derating)		50 / 60 Hz					
Conventional free air thermal current I <sub>th</sub> - θ ≤ 40 °C		16 A					
I <sub>e</sub> / Rated operational current AC-15 acc. to IEC 60947-5-1	24-127 V 50/60 Hz	6 A					
	220-240 V 50/60 Hz	4 A					
	380-440 V 50/60 Hz	3 A					
	500 V 50/60 Hz	2 A					
	690 V 50/60 Hz	2 A					
Making capacity AC-15		10 x I <sub>e</sub> AC-15 acc. to IEC 60947-5-1					
Breaking capacity AC-15		10 x I <sub>e</sub> AC-15 acc. to IEC 60947-5-1					
I <sub>e</sub> / Rated operational current DC-13 acc. to IEC 60947-5-1	24 V DC	6 A / 144 W					
	48 V DC	2.8 A / 134 W					
	72 V DC	2 A / 144 W					
	110 V DC	1.1 A / 121 W					
	125 V DC	1.1 A / 138 W					
	220 V DC	0.55 A / 121 W					
	250 V DC	0.55 A / 138 W					
Short-circuit protection device gG type fuse		10 A					
Rated short-time withstand current I <sub>cw</sub>	for 1.0 s	100 A					
	for 0.1 s	140 A					
Minimum switching capacity with failure rate acc. to IEC 60947-5-4		12 V / 3 mA					
Non-overlapping time between N.O. and N.C. contacts		≥ 2 ms					
Power dissipation per pole at 6 A		0.1 W					
Max. electrical switching frequency	AC-15	1200 cycles/h					
	DC-13	900 cycles/h					
Mechanically linked contacts acc. to annex L of IEC 60947-5-1		Built-in N.O. or N.C. auxiliary contacts and additional N.O. or N.C. auxiliary contacts of 4-pole CA5X are mechanically linked contacts.					
Mirror contacts acc. to annex F of IEC 60947-4-1		Built-in N.C. auxiliary contacts or additional N.C. auxiliary contacts (CA5X, CAL5X-11) are mirror contacts.					

#### Built-in auxiliary contacts according to UL / CSA

Contactor types	AC operated	AX09	AX12	AX18	AX25	AX32	AX40
Max. operational voltage		600 V AC, 600 V DC					
Pilot duty		A600, P300					
AC thermal rated current		10 A					
AC maximum volt-ampere making		7200 VA					
AC maximum volt-ampere breaking		720 VA					
DC thermal rated current		5 A					
DC maximum volt-ampere making-breaking		138 VA					

## AX09 ... AX80 contactors

### DC circuit switching

#### General

- The arc switching on DC is more difficult than on AC.
- For selecting a contactor it is essential to determine the current, the voltage and the L/R time constant of the controlled load.
- For information, typical time constant values are quoted hereafter: non inductive loads such as resistance furnaces ( $L/R \approx 1$  ms), inductive loads such as shunt motors ( $L/R \approx 2$  ms) or series motors ( $L/R \approx 7.5$  ms).
- The addition of a resistor in parallel with an inductive winding helps in the elimination of the arcs.
- All the poles required for breaking must be connected in series between the load and the source polarity not linked to earth (or chassis).



#### Technical data

- The tables indicate for the standard contactors the  $I_e$  max. operating currents depending on: the utilization category (i.e. L/R) DC-1, DC-3, DC-5 as defined in the IEC 60947-4-1 publication, the operating voltage  $U_e$  and the pole coupling details.
- Ampere values quoted in these tables are valid for a  $-25...+70$  °C temperature close to the contactors, as long as these values do not exceed the AC-1 Ampere values for the corresponding ambient temperature.
- Max. switching frequency: 300 cycles/h.



#### Selection table

Contactor types	AX09	AX12	AX18	AX25	AX32	AX40	AX50	AX65	AX80
-----------------	------	------	------	------	------	------	------	------	------



#### Utilization category DC-1, $L/R \leq 1$ ms

	$\leq 72$ V	22	25	27	30	50	60	100	110	120
	110 V	8	10	15	20	-	-	-	-	-
	220 V	-	-	-	-	-	-	-	-	-
	$\leq 72$ V	22	25	27	30	50	60	100	110	120
	110 V	22	25	27	30	50	60	100	110	120
	220 V	8	10	15	20	-	-	-	-	-
	$\leq 72$ V	22	25	27	30	50	60	100	110	120
	110 V	22	25	27	30	50	60	100	110	120
	220 V	22	25	27	30	50	60	100	110	120

#### Utilization category DC-3, $L/R \leq 2$ ms

	$\leq 72$ V	22	25	27	30	50	60	100	110	120
	110 V	5	6	7	8	-	-	-	-	-
	220 V	-	-	-	-	-	-	-	-	-
	$\leq 72$ V	22	25	27	30	50	60	100	110	120
	110 V	22	25	27	30	50	60	100	110	120
	220 V	5	6	7	8	-	-	-	-	-
	$\leq 72$ V	22	25	27	30	50	60	100	110	120
	110 V	22	25	27	30	50	60	100	110	120
	220 V	22	25	27	30	50	60	100	110	120

#### Utilization category DC-5, $L/R \leq 7.5$ ms

	$\leq 72$ V	7	9	12	16	30	40	50	63	75
	110 V	3	4	4	4	-	-	-	-	-
	220 V	-	-	-	-	-	-	-	-	-
	$\leq 72$ V	22	25	27	30	50	60	100	110	120
	110 V	8	10	15	20	45	50	80	90	100
	220 V	3	4	4	4	-	-	-	-	-
	$\leq 72$ V	22	25	27	30	50	60	100	110	120
	110 V	22	25	27	30	50	60	100	110	120
	220 V	7	9	12	16	30	40	50	63	75



## 3-pole contactors

### Electrical durability and utilization categories

#### General

Utilization categories determine the current making and breaking conditions relating to the characteristics of the loads to be controlled by the contactors. International standard IEC 60947-4-1 and European standard EN 60947-4-1 are the standards to be referred to.

If  $I_c$  is the current to be broken by the contactor and  $I_e$  the rated operational current normally drawn by the load, then:

- Categories AC-1 and AC-3: .....  $I_c = I_e$
- Category AC-2: .....  $I_c = 2.5 \times I_e$
- Category AC-4: .....  $I_c = 6 \times I_e$

Generally speaking  $I_c = m \times I_e$  where  $m$  is a multiple of the load operational current.

On next pages, the curves corresponding to categories AC-1, AC-3 and AC-4 represent the electrical durability variation of standard contactors in relation to the breaking current  $I_c$ .

Electrical durability is expressed in millions of operating cycles.

#### Curve utilization mode

##### Electrical durability forecast and contactor selection for categories AC-1, AC-2, AC-3 or AC-4

- Note the characteristics of the load to be controlled:
  - Operational voltage .....  $U_e$
  - Current normally drawn .....  $I_e$  ( $U_e / I_e$  / kW relation for motors, see "Motor rated operational powers and currents").
  - Utilization category ..... AC-1, AC-2, AC-3 or AC-4
  - Breaking current .....  $I_c = I_e$  for AC-1 and for AC-3;  $I_c = 2.5 \times I_e$  for AC-2;  $I_c = 6 \times I_e$  for AC-4
- Define the number of operating cycles  $N$  required.
- On the diagram corresponding to the operational category, select the contactor with the curve immediately above the intersection point ( $I_c$  ;  $N$ ).

##### Electrical durability forecast and contactor selection for mixed duty motor control: AC-3 ( $I_c = I_e$ ) type switching off while "motor running" and, occasionally, AC-4 ( $I_c = 6 \times I_e$ ) type switching off while "motor accelerating"

- Note the characteristics of the motor to be controlled:
  - Operational voltage .....  $U_e$
  - Current normally drawn while "motor running" .....  $I_e$  ( $U_e / I_e$  / kW relation for motors, see "Motor rated operational powers and currents")
  - Breaking current for AC-3 .....  $I_c = I_e$
  - Breaking current for AC-4 while "motor accelerating" .....  $I_c = 6 \times I_e$
  - Percentage of AC-4 operating cycles .....  $K$  (on the basis of the total number of operating cycles)
- Define the total number of operating cycles  $N$  required.
- Note the smallest contactor rating compatible for AC-3 ( $U_e / I_e$ ) on Main pole utilization characteristic table (see "Technical data").
- For the selected contactor make a note of the following in relation to the voltage using diagram AC-3 in next pages:
  - The number of operating cycles  $A$  for  $I_c = I_e$  (AC-3)
  - The number of operating cycles  $B$  for  $I_c = 6 \times I_e$  (AC-4)
- Calculate the estimated number of cycles  $N'$  ( $N'$  is always below  $A$ )

$$N' = \frac{A}{1 + 0.01 K (A/B - 1)}$$

- If  $N'$  is too low in relation to the target  $N$ , calculate the estimated number of cycles for a higher contactor rating.

#### Case of uninterrupted duty

For uninterrupted duty, some verifications of preventing maintenance are necessary to check the functionality of the concerned product (consult us).

The combined effect of environmental conditions and the proper temperature of the product may require some disposals. As a matter of fact, for this duty, the use duration prevails over the number of operating cycles.

### 3-pole contactors

#### Electrical durability

#### Electrical durability for AC-1 utilization category - $U_e \leq 690\text{ V}$

Switching non-inductive or slightly inductive loads. The breaking current  $I_c$  for AC-1 is equal to the rated operational current of the load.

Ambient temperature and maximum electrical switching frequency: see "Technical data".

Millions of operating cycles

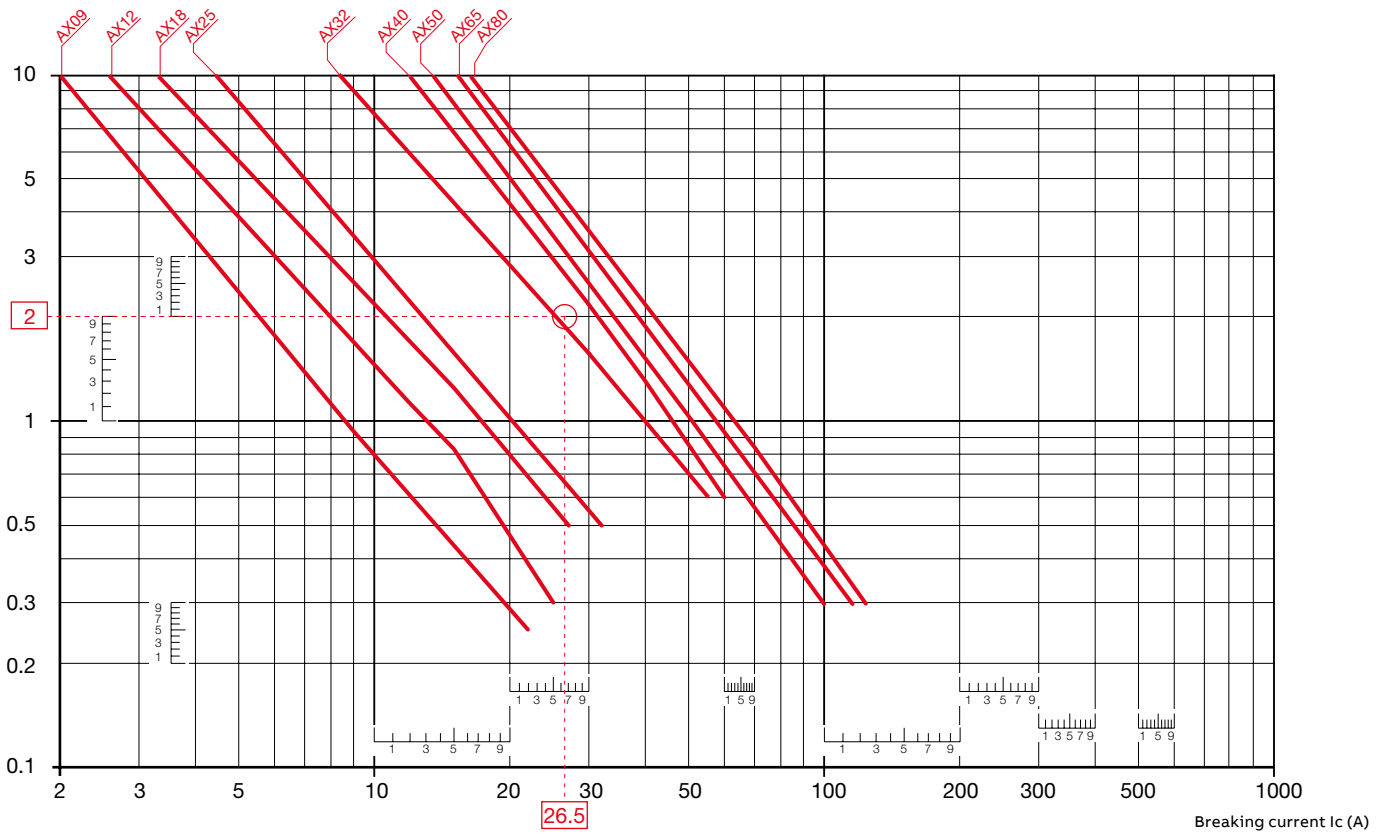

#### Example:

$I_c / AC-1 = 26.5\text{ A}$  – Electrical durability required = 2 millions operating cycles.

Using the AC-1 curves above select the AX32 contactor at intersection "O" (26.5 A / 2 millions operating cycles).

## 3-pole contactors

### Electrical durability

#### Electrical durability for AC-3 utilization category - $U_e \leq 440$ V.

Switching cage motors: starting and switching off running motors. The breaking current  $I_c$  for AC-3 is equal to the rated operational current  $I_e$  ( $I_e$  = motor full load current).

Ambient temperature and maximum electrical switching frequency: see "Technical data".

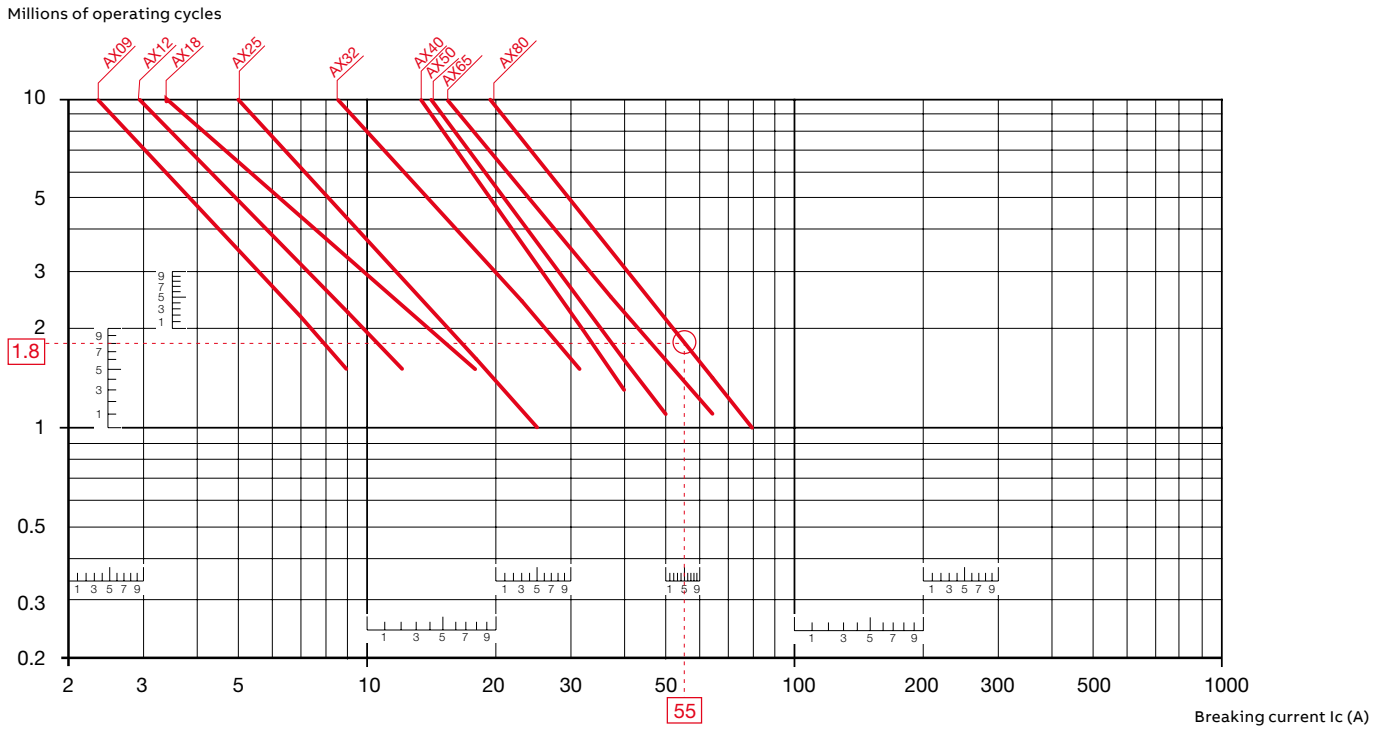

#### Example:

Motor power 30 kW for AC-3 -  $U_e = 400$  V and  $I_e = 55$  A utilization – Electrical durability required = 1.8 million operating cycles. For AC-3:  $I_c = I_e$ . Select the AX80 contactor at intersection "O" (55 A / 1.8 million operating cycles) on the curves (AC-3 -  $U_e \leq 440$  V).

### 3-pole contactors

#### Electrical durability

**Electrical durability for AC-4 utilization category -  $U_e \leq 440\text{ V}$**

**Ambient temperature  $\leq 55\text{ }^\circ\text{C}$**

Switching cage motors: starting, reverse operation and step-by-step operation. The breaking current  $I_c$  is equal to  $6 \times I_e$  for AC-4, keeping in mind that  $I_e$  is the motor rated operational current ( $I_e =$  motor full-load current).

Maximum electrical switching frequency: see "Technical data".

Millions of operating cycles

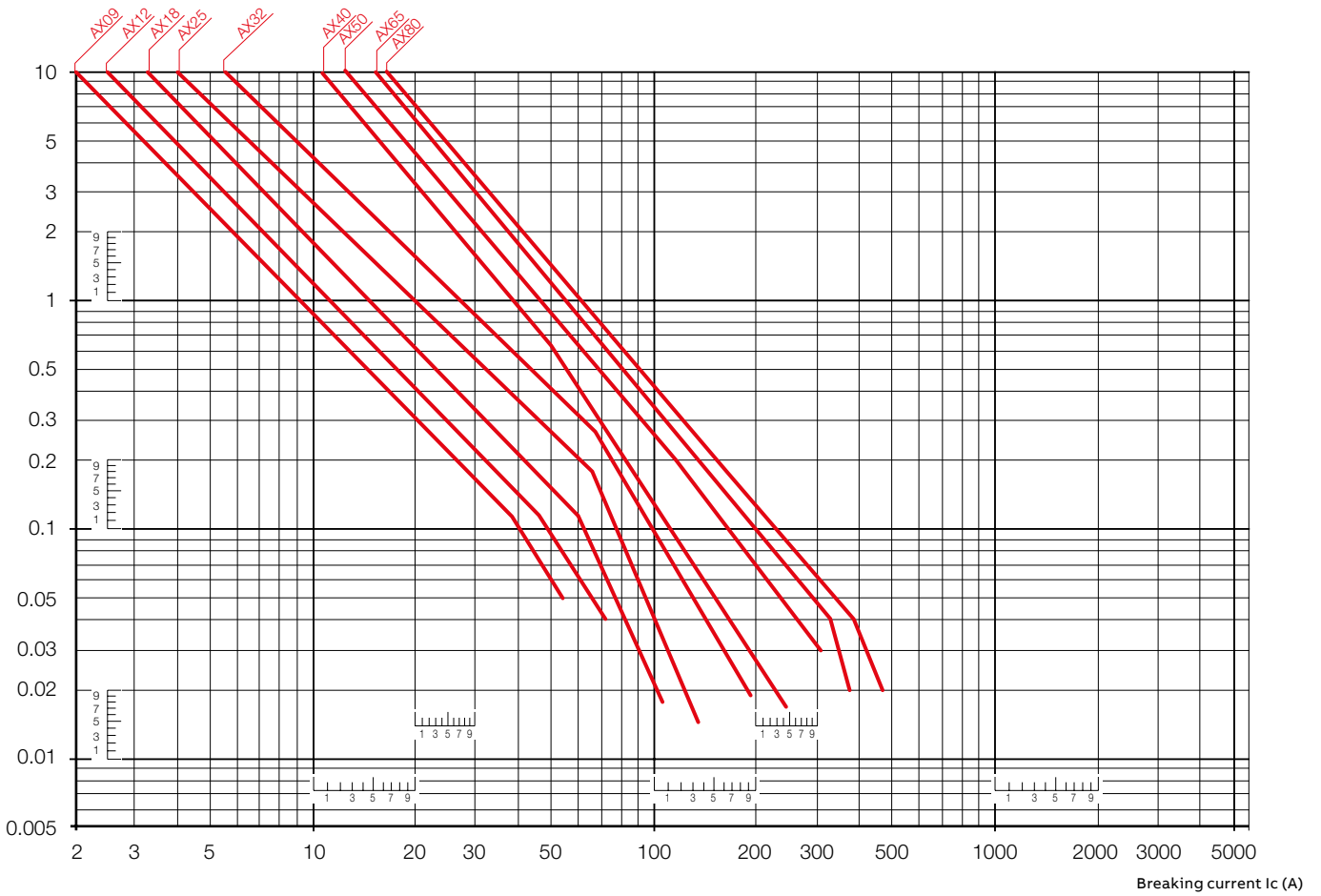

03

## Star-delta starting of three-phase asynchronous motors

### Contactor selection

#### General

Star-delta starting is the most common method to reduce the starting current of a motor. This system can be used on all the squirrel cage motors, which are normally used in delta connection.

In this type of starting, it is recommended to choose motors having high starting torque i.e. much higher than the resistive torque in order to reach sufficient high speed when the motor is connected in star.

#### Star-delta starting

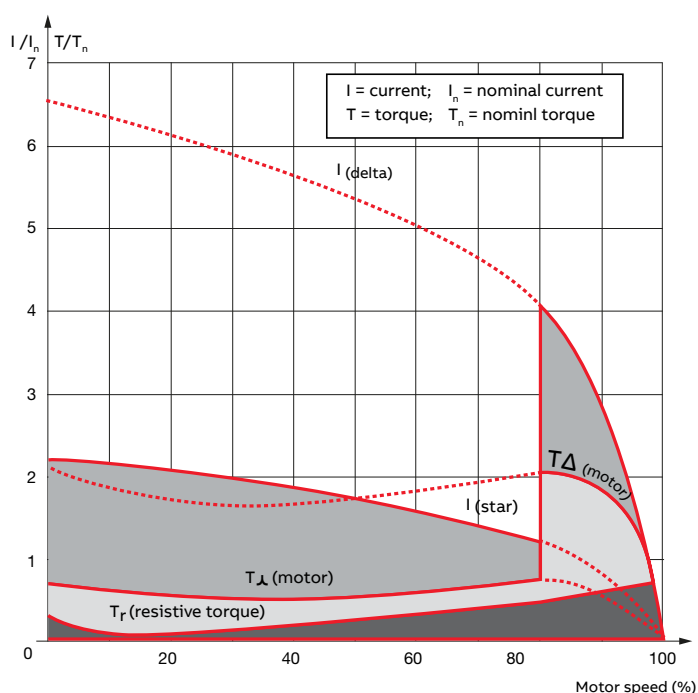

#### Technical Data

When starting:  
 inrush current is reduced to a third of direct starting current  
 motor torque is reduced to a third or even less of direct starting torque.  
 Transient current is generated when switching from star to delta connection.

#### Utilization

During the initial starting phase ("star" connection), the resistive torque of the driven load must remain, irrespective of speed, less than the "star" motor torque until "star-delta" switching occurs.

This starting mode is therefore ideal for machines having high starting torque such as:

- pumps
- centrifugal compressors
- wood-working machines, etc.

In order to prevent a high current peak, at least 85% of nominal speed must be reached before switching from star to delta.

#### Precautions

Motor nominal voltage in delta connection must be equal to that of the mains.

Example:

A motor for 415 V star-delta starting must be designed for 415 V in "delta" connection. Its usual designation is "415 V / 690 V motor". The motor must be constructed with 6 terminal windings.

#### Sequence

Starting is a three-stage process:

##### 1st stage - "Star" connection

Press the "On" button on the control circuit to close the KM2 "star" contactor. The KM1 "line" contactor then closes and the motor starts. Countdown of programmed starting time (normally 6 to 16 s) then begins.

##### 2nd stage - "Star" to "Delta" switching

When the programmed starting time is over, the KM2 "star" contactor opens.

##### 3rd stage - "Delta" connection

A transition time (or dwelling time) of 50 ms is fixed between opening of the "star" contactor and closing of the "delta" contactor by the use of CT-SDS timer. This prevents short circuit between "star" and "delta".

Note: An electrical interlock between star and delta is mandatory such as VE 5 or through auxiliary contacts. Furthermore, in open transition, the current interruption may reach up to 95 ms: it shall be checked that this duration is compatible with the application i.e. mainly if the decreasing in rotation speed is acceptable during the starting phase.

# Star-delta starting of three-phase asynchronous motors

## Contactor selection

Rated operational power - AC-3									Max. starting time from cold state(1) seconds	Line contactor	Delta contactor	Star contactor	Overload relay (2)	Timer
220-230 V kW	240 V kW	380 V kW	400 V kW	415 V kW	440 V kW	500 V kW	660 V kW	690 V kW						
7.5	9	15	15	15	11	11	11	11	15	AX18	AX18	AX12	TA25DU M	CT-SDS.22S
11	11	22	22	22	15	15	15	15	15	AX25	AX25	AX18	TA25DU M	CT-SDS.22S
15	15	25	30	30	30	30	30	30	15	AX32	AX32	AX25	TA42DU M	CT-SDS.22S
18.5	22	37	37	37	37	37	37	37	30	AX40	AX40	AX32	TA42DU M	CT-SDS.22S
25	30	45	45	45	45	55	55	55	30	AX50	AX50	AX32	TA75DU M	CT-SDS.22S
30	37	55	55	55	55	55	55	55	30	AX65	AX65	AX40	TA75DU M	CT-SDS.22S
37	45	55	75	75	75	75	75	75	30	AX80	AX80	AX50	TA75DU M	CT-SDS.22S
45	55	75	90	90	90	90	90	90	20	AX95	AX95	AX65	TA110DU-M	CT-SDS.22S
55	55	90	110	110	110	110	132	132	20	AX115	AX115	AX80	TA110DU-M	CT-SDS.22S
75	75	132	132	132	110	110	132	132	20	AX150	AX150	AX95	TA110DU-M	CT-SDS.22S

(1) Usual time value = 6...16 s.

(2) The setting current value is : nominal motor current x 0.58

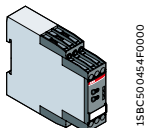

CT-SDS...

### Ordering details - Electronic timer

Timing function	Time ranges	Ouput	Rated control supply voltage	Type	Order code	Pkg qty	Weight (1 pce) kg
Star-delta change-over (3)	7 (0.05 s - 10 min)	2 n/o contacts, 3 LEDs	28-48 V DC	CT-SDS.22S	1SVR730210R3300	1	0.114
			24-240 V AC 380-440 V AC	CT-SDS.23S	1SVR730211R2300	1	0.118
ON-delay (4)	10 (0.05 s - 300h)	2 c/o SPDT contacts	24-240 V AC/DC	CT-ERS.21S	1SVR730100R0300	1	0.152

(3) 50 ms transition time

(4) No transition time

### Power circuit diagram

AX09 ... AX150 contactors

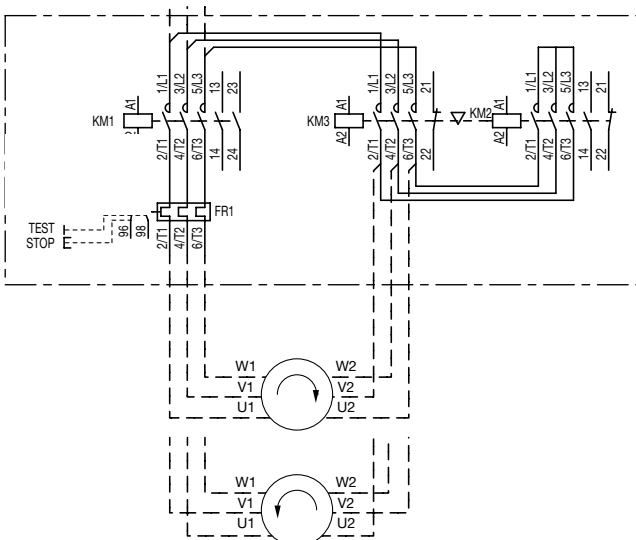

### Control circuit diagrams - Remote control

AX09 ... AX150 contactors

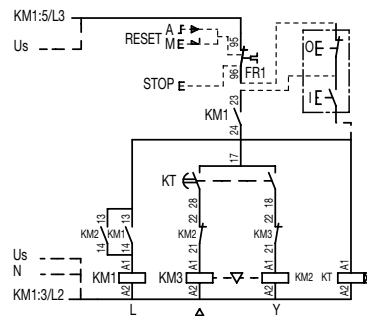

# AX09 ... AX150 3-pole contactors

## Terminal marking and positioning

### AX09 ... AX150 contactors - AC operated

Standard devices without addition of auxiliary contacts

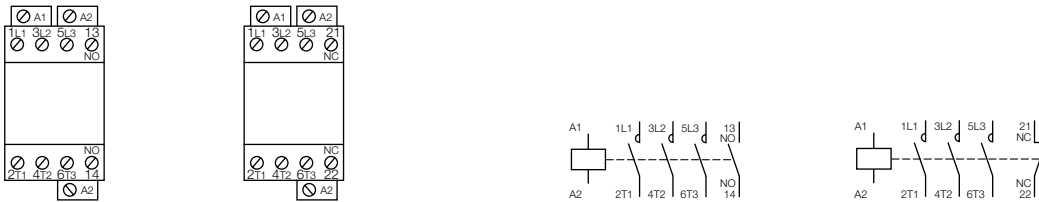

### Standard devices with factory mounted auxiliary contacts



### Other possible contact combinations with auxiliary contacts added by the user

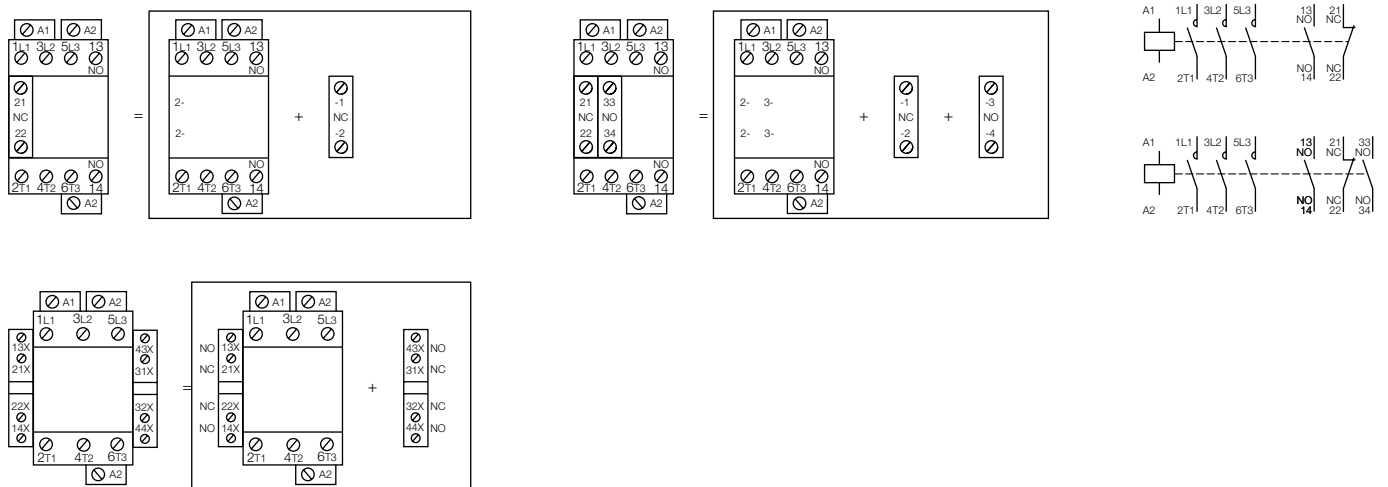

# AX09 ... AX40 3-pole contactors

## Dimensions

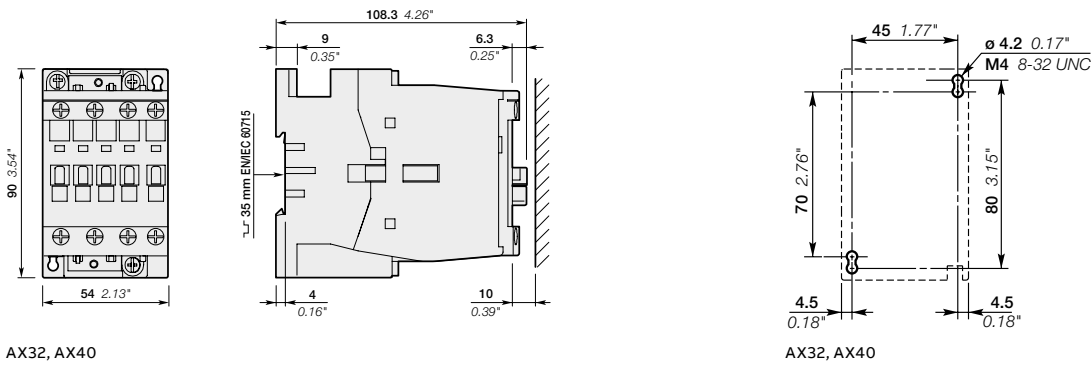
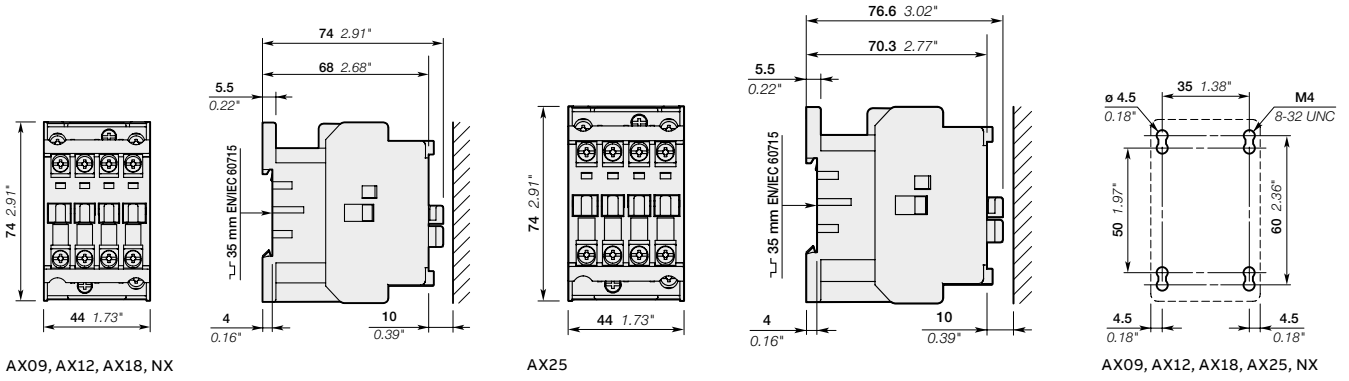



# AX50 ... AX150 3-pole contactors

## Dimensions

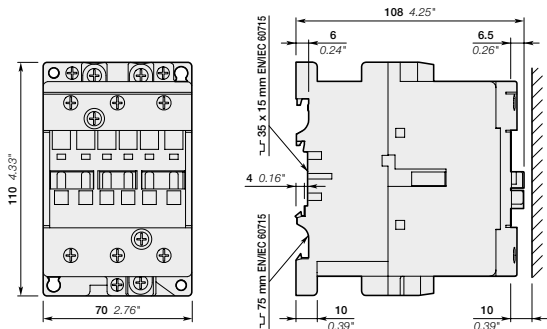

AX50, AX65, AX80

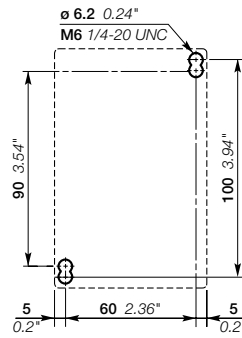

AX50, AX65, AX80

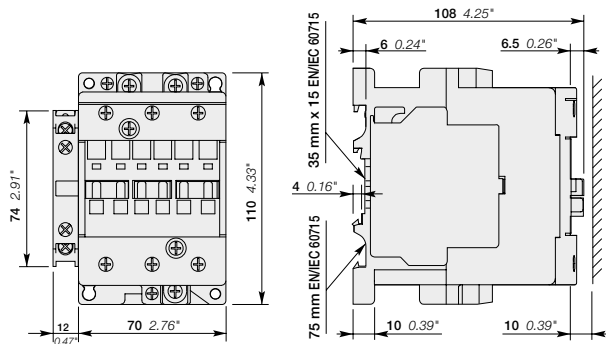

AX50, AX65, AX80 + CAL5X-11

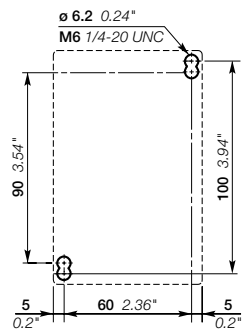

AX50, AX65, AX80 + CAL5X-11

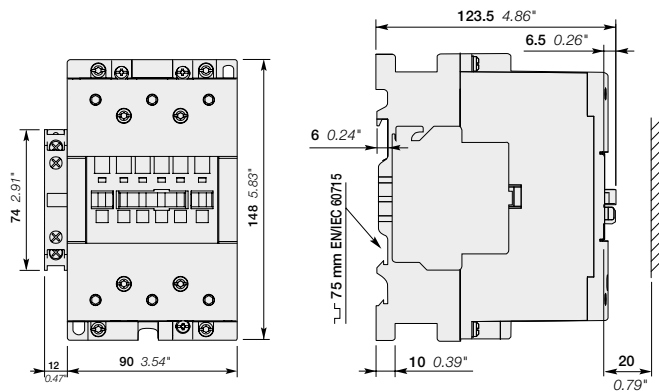

AX95, AX115, AX150 + CAL18X-11

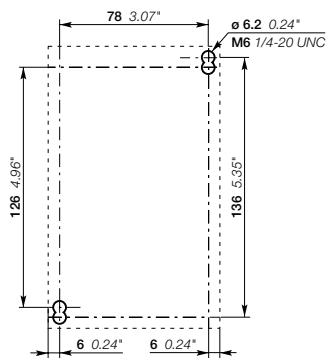

AX95, AX115, AX150 + CAL18X-11

Main dimensions mm, inches



---

# NX contactor relays

## Ordering details

### NX contactor relays

- 58 AC operated
- 59 Main accessories

## 60 Technical data

## 62 Terminal marking and positioning

## 85 Voltage code table

# NX contactor relays

AC operated



NX40E

NX contactor relays are used for switching auxiliary circuits and control circuits.

These contactor relays are of the block type design with:

- 4 poles. Contactor relays have mechanically linked auxiliary contact elements
- control circuit: AC operated
- add-on auxiliary contact blocks for front or side mounting and a wide range of accessories.

Number of contacts	Rated control circuit voltage U <sub>c</sub> (1)		Type	Order code	Weight (1 pce) kg
	V 50 Hz	V 60 Hz			
	24	24	NX22E-81	1SBH901074R8122	0.340
	105	110...127	NX22E-26	1SBH901074R2622	0.340
	200	200...220	NX22E-75	1SBH901074R7522	0.340
	380...400	400...415	NX22E-85	1SBH901074R8522	0.340
	24	24	NX31E-81	1SBH901074R8131	0.340
	105	110...127	NX31E-26	1SBH901074R2631	0.340
	200	200...220	NX31E-75	1SBH901074R7531	0.340
	380...400	400...415	NX31E-85	1SBH901074R8531	0.340
	24	24	NX40E-81	1SBH901074R8140	0.340
	105	110...127	NX40E-26	1SBH901074R2640	0.340
	200	200...220	NX40E-75	1SBH901074R7540	0.340
	380...400	400...415	NX40E-85	1SBH901074R8540	0.340

(1) For other voltage version see voltage code table.

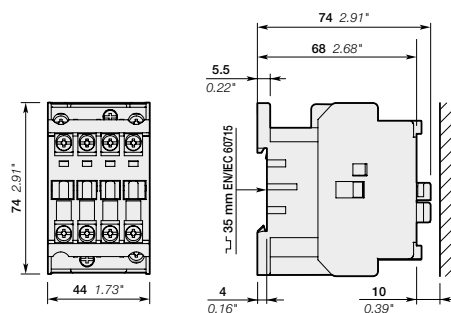

NX22E, NX31E, NX40E

Main dimensions mm, inches

# NX contactor relays

## Main accessories

### Contactor relay and main accessories (other accessories available)

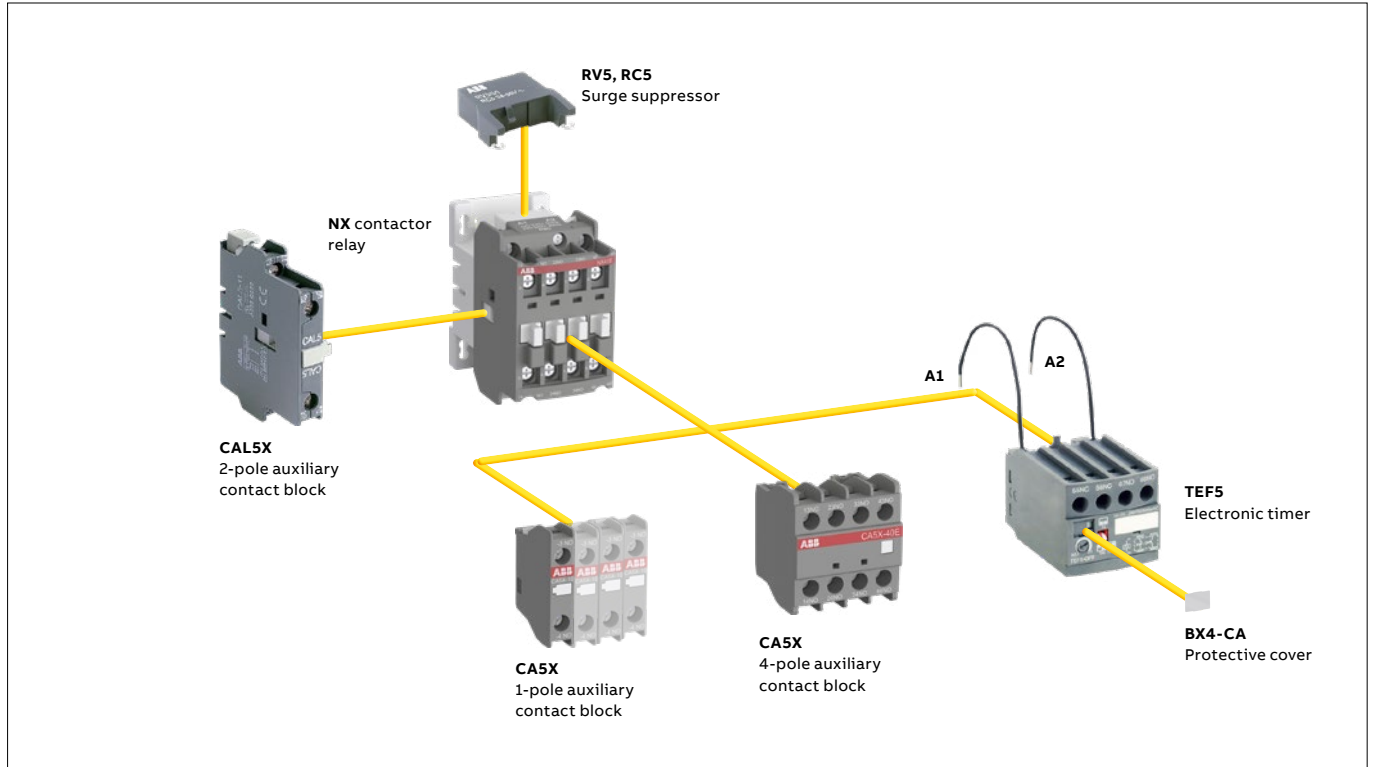

### Main accessory fitting details

Many configurations of accessories are possible depending on whether these are front-mounted or side-mounted.

Contactor types	Main poles 	Front-mounted accessories			Side-mounted accessories	
		Auxiliary contact blocks		Electronic timer	Auxiliary contact blocks	
NX	2 2 E (1)	1 to 4 x CA5X	or 1 x CA5X (4-pole)	or 1 x TEF5	+	1 to 2 x CAL5X-11
		(or 1 x CE5) (2)				
	3 1 E (1)	1 to 4 x CA5X	or 1 x CA5X (4-pole)	or 1 x TEF5	+	1 to 2 x CAL5X-11
	4 0 E	(1 to 2 x CE5 max) (3)				

(1) 2 N.C. front mounted auxiliary contacts maximum in mounting position 5.  
 (2) CE5 auxiliary contacts not allowed in mounting position 5.  
 (3) The total number of N.O. or N.C. CE5 and other N.C. CA5X auxiliary contacts is limited to 2.

# NX contactor relays

## Technical data

### Contact utilization characteristics according to IEC

Contactor relay types	AC operated	<b>NX</b>
Standards		IEC 60947-1 / 60947-5-1 and EN 60947-1 / 60947-5-1
Rated operational voltage $U_e$ max.		690 V
Rated frequency (without derating)		50 / 60 Hz
Conventional free-air thermal current $I_{th} \theta \leq 40^\circ\text{C}$		16 A
le / Rated operational current AC-15 acc. to IEC 60947-5-1	24-127 V 50/60 Hz	6 A
	220-230 V 50/60 Hz	4 A
	380-415 V 50/60 Hz	3 A
	500 V 50/60 Hz	2 A
	690 V 50/60 Hz	2 A
Rated making capacity AC-15		10 x $I_e$ AC-15 acc. to IEC 60947-5-1
Rated breaking capacity AC-15		10 x $I_e$ AC-15 acc. to IEC 60947-5-1
le / Rated operational current DC-13 acc. to IEC 60947-5-1	24 V DC	6 A / 144 W
	48 V DC	2.8 A / 134 W
	72 V DC	1 A / 72 W
	110 V DC	0.55 A / 60 W
	125 V DC	0.55 A / 69 W
	220 V DC	0.30 A / 66 W
	250 V DC	0.30 A / 75 W
Short-circuit protection device for contactors $U_e \leq 500$ V AC - gG type fuse		10 A
Rated short-time withstand current $I_{cw}$ at $40^\circ\text{C}$ ambient temperature, in free air from a cold state	for 1.0 s	100 A
	for 0.1 s	140 A
Minimum switching capacity with failure rate acc. to IEC 60947-5-4		17 V / 5 mA
Non-overlapping time between N.O. and N.C. contacts		$\geq 2$ ms
Power dissipation per pole at 6 A		0.1 W
Max. electrical switching frequency	AC-15	1200 cycles/h

### Contact utilization characteristics according to UL / CSA

Contactor relay types	AC operated	<b>NX</b>
Standards		UL 508, CSA C22.2 N°14-05
Max. operational voltage		600 V AC
Pilot duty		A600, Q300

### General technical data

Contactor relay types	AC operated	<b>NX</b>
Rated insulation voltage $U_i$ acc. to IEC 60947-5-1		690 V
acc. to UL / CSA		600 V
Rated impulse withstand voltage $U_{imp}$ .		6 kV
Ambient air temperature		
Operation in free air		$-40...+70^\circ\text{C}$
Storage		$-60...+80^\circ\text{C}$
Climatic withstand		acc. to IEC 60068-2-30 and 60068-2-11 - UTE C 63-100 specification II
Maximum operating altitude (without derating)		3000 m
Mechanical durability		
Number of operating cycles		$\geq 20$ millions operating cycles
Max. switching frequency		6000 cycles/h
Shock withstand acc. to IEC 60068-2-27 and EN 60068-2-27		
Mounting position 1		
	Shock direction	1/2 sinusoidal shock for 11 ms: no change in contact position, closed or open position
	A	20 g
	B1	5 g
	B2	15 g
	C1	20 g
	C2	20 g

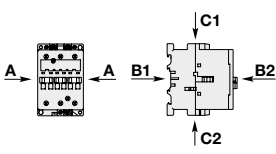

# NX contactor relays

## Technical data

### Magnet system characteristics

Contactor relay types	AC operated	<b>NX</b>	
Coil operating limits acc. to IEC 60947-4-1	<b>AC supply</b>	at $\theta \leq 55^\circ\text{C}$ 0.85...1.1 x $U_c$ Please also refer to "Mounting characteristics and conditions for use"	
AC control voltage 50/60 Hz			
Rated control circuit voltage $U_c$	at 50 Hz	24...440 V	
	at 60 Hz	24...440 V	
Coil consumption	Average pull-in value	50 Hz	70 VA
		60 Hz	80 VA
	50/60 Hz (1)	74 VA / 70 VA	
	Average holding value	50 Hz	8 VA / 2 W
		60 Hz	8 VA / 2 W
50/60 Hz (1)		8 VA / 2 W	
Drop-out voltage		approx. 40...65 % of $U_c$	
Operating time			
Between coil energization and:	<b>N.O. contact closing</b>	10...26 ms	
	<b>N.C. contact opening</b>	7...21 ms	
Between coil de-energization and:	<b>N.O. contact opening</b>	4...11 ms	
	<b>N.C. contact closing</b>	9...16 ms	

(1) 50/60 Hz coils: see "Coil voltage code table".

### Mounting characteristics and conditions for use

Contactor relay types	AC operated	<b>NX</b>
Mounting positions		
Control voltage / Ambient temperature		
Mounting positions	1, 1±30°, 2, 3, 4, 5	at $\theta \leq 55^\circ\text{C}$ 0.85...1.1 x $U_c$
		at $\theta \leq 70^\circ\text{C}$ $U_c$
	6	at $\theta \leq 55^\circ\text{C}$ 0.95...1.1 x $U_c$
		at $\theta \leq 70^\circ\text{C}$ unauthorized
Mounting distances		The contactors can be assembled side by side
Fixing		
On rail according to IEC 60715, EN 60715		35 x 7.5 mm or 35 x 15 mm
By screws (not supplied)		2 x M4 screws placed diagonally

Add-on N.O. or N.C. auxiliary contacts:  
see accessory fitting details for contactor relays

### Connecting characteristics

Contactor relay types	AC operated	<b>NX</b>	
Main terminals		<p>Screw terminals with cable clamp</p>	
Connection capacity (min. ... max.)			
Main conductors (poles + coil terminals)			
Rigid	1 x	1...4 mm <sup>2</sup>	
	2 x	1...4 mm <sup>2</sup>	
Flexible with ferrule	1 x	0.75...2.5 mm <sup>2</sup>	
	2 x	0.75...2.5 mm <sup>2</sup>	
Bars or lugs	Pole terminals	L <	7.7 mm
		I <	3.7 mm
	Coil terminals	L <	8 mm
		I <	3.7 mm
Connection capacity acc. to UL / CSA	1 or 2 x	AWG 18...14	
Stripping length		10 mm	
Tightening torque		1 Nm / 9 lb.in	
Degree of protection acc. to IEC 60947-1 and IEC 60529			
All terminals		IP20 (only front side)	
Screw terminals		Delivered in open position, screws of unused terminals must be tightened	
All terminals		M3.5	
Screwdriver type		Flat Ø 5.5 / Pozidriv 2	

# NX contactor relays

## Terminal marking and positioning

### NX contactor relays - AC operated

Standard devices without addition of auxiliary contacts

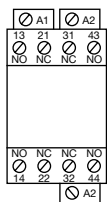

NX22E

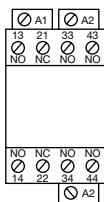

NX31E

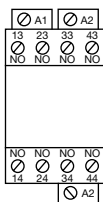

NX40E

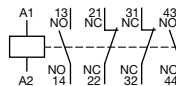

NX22E

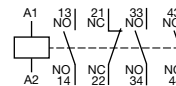

NX31E

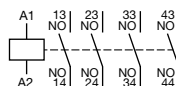

NX40E

Other possible contact combinations with auxiliary contacts added by the user

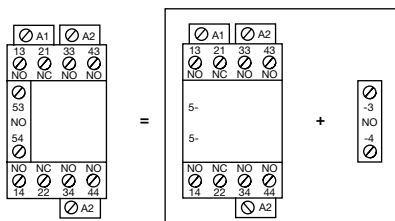

Combination 41E =

NX31E + CA5X-10

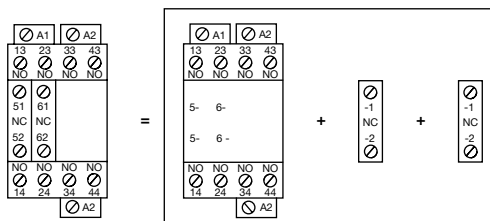

Combination 42E =

NX40E + CA5X-01 + CA5X-01



Combination 41E



Combination 42E

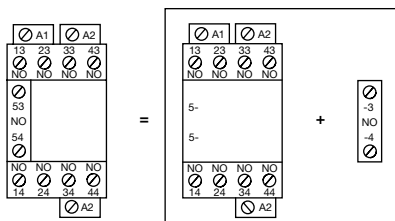

Combination 50E =

NX40E + CA5X-10

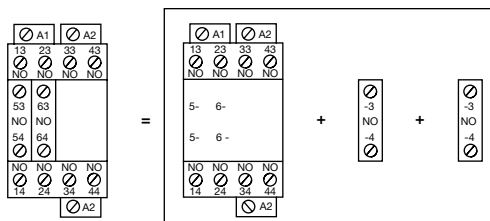

Combination 60E =

NX40E + CA5X-10 + CA5X-10



Combination 50E

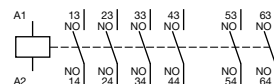

Combination 60E



---

# Accessories for AX09 ... AX150 3-pole contactors and NX contactor relays

	<b>Auxiliary contact blocks</b>
64	Ordering details
65	Technical data
68	Terminal marking and positioning
	<b>Electronic timers</b>
69	Ordering details
70	Technical data
	<b>Mechanical and electrical interlock units</b>
72	Ordering details
73	Technical data
	<b>Interface relays</b>
74	Ordering details
75	Technical data
	<b>Mechanical latching units</b>
76	Ordering details
77	Technical data
	<b>Surge suppressors for contactor coils</b>
78	Ordering details
79	Technical data
80	<b>Additional terminal blocks</b>
81	<b>Function markers</b>
82	<b>Terminal connecting strips and shorting bars</b>
83	<b>Connection accessories for starting solutions</b>
84	<b>Phase to phase connections</b>

## Auxiliary contact blocks



AX07015

CA5X-10



AX07013 CA5X-4P

CA5X-4P



1SBC57375-P0301

CAL5X-11

The auxiliary contact blocks are used for the operation of auxiliary circuits and control circuits for standard industrial environments.

Types of auxiliary contact blocks for front mounting:

- CA5X 1 or 4-pole block, instantaneous with N.O., N.C. contacts.

Select the 4-pole auxiliary contact blocks CA5X-..E, CA5X-..M, according to the contactor type for compliance with the standard requirements (see "Terminal Marking and Positioning").

Types of auxiliary contact blocks for side mounting:

- CAL... 2-pole block instantaneous N.O. + N.C. contacts.

For clipping onto the right- and/or left-hand side of the contactors.

The auxiliary contact blocks are equipped with screw type connecting terminals delivered open, protected against accidental direct contact and bear the corresponding function marking.

For contactors	Auxiliary contacts	Type	Order code	Pkg qty	Weight (1 pce)
					kg
<b>Front-mounted instantaneous auxiliary contact blocks</b>					
AX09 ... AX150 and NX 4-pole	1 –	CA5X-10	1SBN019010R1010	10	0.014
	– 1	CA5X-01	1SBN019010R1001	10	0.014
AX50 ... AX150	2 2	CA5X-22E	1SBN019040R1022	2	0.060
AX09 ... AX40-30-10	2 2	CA5X-22M	1SBN019040R1122	2	0.060
<b>Side-mounted instantaneous auxiliary contact block, 2 pole</b>					
AX09 ... AX80 and NX - 4 pole	1 1	CAL5X-11	1SBN019020R1011	2	0.050
AX95 ... AX150	1 1	CAL18X-11	1SBN019820R1011	2	0.050

For each contactor or contactor relay, refer to "Accessories fitting details" table.

# Auxiliary contact blocks

## Technical data



### Contact utilization characteristics according to IEC

Types	Front mounted		Side mounted	
	1-pole CA5X, 4-pole CA5X		CAL5X-11	CAL18X-11, CAL18X-11B
Standards	IEC 60947-5-1 and EN 60947-5-1			
Rated insulation voltage Ui acc. to IEC 60947-5-1	690 V			
Rated operational voltage Ue max.	24...690 V AC			
Conventional thermal current Ith - $\theta \leq 40^\circ\text{C}$	16 A			
le / Rated operational current AC-15 acc. to IEC 60947-5-1	24-127 V 50/60 Hz	6 A		
	220-240 V 50/60 Hz	4 A		
	380-440 V 50/60 Hz	3 A		
	500-690 V 50/60 Hz	2 A		
Making capacity	10 x Ie AC-15 acc. to IEC 60947-5-1			
Breaking capacity	10 x Ie AC-15 acc. to IEC 60947-5-1			
le / Rated operational current DC-13 acc. to IEC 60947-5-1	24 V DC	6 A / 144 W		
	48 V DC	2.8 A / 134 W		
	72 V DC	1 A / 72 W		
	110 V DC	0.55 A / 60 W		
	125 V DC	0.55 A / 69 W		
	220 V DC	0.3 A / 66 W		
	250 V DC	0.3 A / 75 W		
Short-circuit protection device gG type fuse	10 A			
Rated short-time withstand current Icw $\theta = 40^\circ\text{C}$	for 1.0 s	100 A		
	for 0.1 s	140 A		
Minimum switching capacity AX09 ... AX80 contactors with failure rate acc. to IEC 60947-5-4	12 V / 3 mA	-		
	$\leq 10^{-6}$	-		
AX95 ... AX150 contactors with failure rate acc. to IEC 60947-5-4	24 V / 50 mA	-	24 V / 50 mA (0.5 million of operating cycles)	
	-	-	$\leq 10^{-6}$	
AX185 ... AX205 contactors with failure rate acc. to IEC 60947-5-4	-	-	24 V / 50 mA (0.5 million of operating cycles)	
	-	-	$\leq 10^{-6}$	
AX260 ... AX370 contactors with failure rate acc. to IEC 60947-5-4	-	-	-	
	-	-	-	
Power dissipation per pole at 6 A	0.1 W		0.15 W	
Mechanical durability Number of operating cycles	10 millions (AX09 ... AX80) 3 millions (AX95 ... AX150)	10 millions		5 millions (AX95 ... AX205)
	Max. switching frequency	3600 cycles/h		
Max. electrical switching frequency	AC-15	1200 cycles/h		
	DC-13	900 cycles/h		

### Contact utilization characteristics according to UL / CSA

Standards	UL 508, CSA C22.2 N°14			
Max. operational voltage	600 V AC, 250 V DC			
Pilot duty	A600, Q300			
AC thermal taed current	10 A			

### Connecting characteristics

Connection capacity (min. ... max.)				
 Rigid solid	1 x	1...4 mm <sup>2</sup>		
	2 x	1...4 mm <sup>2</sup>		
 Flexible with ferrule	1 x	0.75...2.5 mm <sup>2</sup>		
	2 x	0.75...2.5 mm <sup>2</sup>		
 Lugs	L ≤	7.7 mm	8 mm	
	L >	3.7 mm	3.7 mm	
Tightening torque	1 Nm / 9 lb.in			
Connection capacity acc. to UL / CSA	1 or 2 x	AWG 18...14		
Stripping length	1-pole: 11 mm		10 mm	-
	4-pole: 10 mm			
Degree of protection	Terminals	IP20		
acc. to IEC 60947-1 / EN 60947-1 and IEC 60529 / EN 60529				
Screw terminals	Delivered in open position, screws of unused terminals must be tightened			
All terminals	M3.5			
Screwdriver type	Flat Ø 5.5 / Pozidriv 2			

## Auxiliary contact blocks

for severe industrial environments



CE5-01W

The auxiliary contact blocks are used for the operation of auxiliary and control circuits for severe industrial environments.

Types of auxiliary contact blocks for front mounting:

1-pole block, instantaneous with N.O. contact or N.C. contact, designed in 2 protection versions:

CE5-..D with built-in microswitch IP40, degree of protection (IP20 on terminals)

CE5-..W with built-in microswitch IP67, degree of protection (IP20 on terminals).

The auxiliary contact blocks are equipped with screw type connecting terminals delivered open, protected against accidental direct contact and bear the corresponding function marking each side of the mechanical latch).

For contactors	Auxiliary contacts	Type	Order code	Pkg qty	Weight (1 pce)
					kg

### Front-mounting instantaneous auxiliary contact blocks, 1-pole

AX09 ... AX80, NX	1	-	-	-	Type	Order code	Pkg qty	Weight (1 pce)
	1	-	-	-	CE5-10D0.1	1SBN010015R1010	1	0.020
	-	1	-	-	CE5-01D0.1	1SBN010015R1001	1	0.020
	1	-	-	-	CE5-10D2	1SBN010017R1010	1	0.020
	-	1	-	-	CE5-01D2	1SBN010017R1001	1	0.020
	1	-	-	-	CE5-10W0.1	1SBN010016R1010	1	0.020
	-	1	-	-	CE5-01W0.1	1SBN010016R1001	1	0.020
	1	-	-	-	CE5-10W2	1SBN010018R1010	1	0.020
	-	1	-	-	CE5-01W2	1SBN010018R1001	1	0.020

For each contactor type, refer to "Accessory fitting details" table.

## Auxiliary contact blocks

### Technical data



#### Contact utilization characteristics according to IEC

Types	Front-mounted	1-pole CE5-..0.1	1-pole CE5-..2
Standards	IEC 60947-5-1 and EN 60947-5-1		
Rated insulation voltage $U_i$ acc. to IEC 60947-5-1	250 V		
Rated operational voltage $U_e$ max.	125 V		250 V
Conventional thermal current $I_{th} - \theta \leq 40^\circ\text{C}$	0.1 A		
$I_e$ / Rated operational current acc. to IEC 60947-5-1		AC-14	AC-15
	24-127 V 50/60 Hz	0.1 A	2 A
	220-240 V 50/60 Hz	–	2 A
Making capacity acc. to IEC 60947-5-1	6 x $I_e$ AC-14		
Breaking capacity acc. to IEC 60947-5-1	6 x $I_e$ AC-14		
$I_e$ / Rated operational current DC-12 acc. to IEC 60947-5-1	24 V DC	0.1 A	2 A
	48 V DC	0.1 A	1 A
	72 V DC	0.1 A	0.3 A
	110 V DC	0.1 A	0.2 A
	125 V DC	–	0.2 A
	220 V DC	–	0.1 A
Short-circuit protection device	0.1 A (FF type fuses) (1)		10 A (FF type fuses) (1)
Minimum switching capacity			
AX09 ... AX80, NX contactors	3 V / 1 mA		
With failure rate acc. to IEC 60947-5-4	–		
Mechanical durability	Number of operating cycles	5 millions for CE5-..D0.1	
		2.5 millions for CE5-..W0.1	
		2.5 millions for CE5-..W2	
	Max. switching frequency	3600 cycles/h	
Electrical durability	Number of operating cycles	2.5 millions for CE5-..D0.1	
		0.7 millions for CE5-..W0.1	
		1 million for CE5-..D2	
	Max. switching frequency	AC-14	1200 cycles/h
		AC-15	1200 cycles/h
		DC-12	900 cycles/h

#### Contact utilization characteristics according to UL / CSA

Standards	UL 508, CSA C22.2 N°14		
Max. operational voltage	125 V AC / 110 V DC		250 V AC / 220 V DC
Pilot duty			
AC thermal rated current	0.1 A		2 A

#### Connecting characteristics

Connection capacity (min. ... max.)			
	Rigid solid	1 x	1...4 mm <sup>2</sup>
		2 x	1...4 mm <sup>2</sup>
	Flexible with ferrule	1 x	0.75...2.5 mm <sup>2</sup>
		2 x	0.75...2.5 mm <sup>2</sup>
	Lugs	L <	7.7 mm
		L >	3.7 mm
Connection capacity acc. to UL / CSA	1 or 2 x	AWG 18...14	
Tightening torque	1 Nm		
Degree of protection	Terminals	IP20	
acc. to IEC 60947-1 / EN 60947-1 and IEC 60529 / EN 60529	Microswitches	IP40 for CE5-..D0.1	
		IP40 for CE5-..D2	
		IP67 for CE5-..W0.1	
		IP67 for CE5-..W2	
Screw terminals	Delivered in open position, screws of unused terminals must be tightened		
All terminals	M3.5		
Screwdriver type	Flat Ø 5.5 / Pozidriv 2		

(1) or HRC fuses for very fast action (6.3 x 32 mm size).

## Add-on auxiliary contacts

### Terminal marking and positioning

#### 1-pole auxiliary contacts

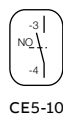
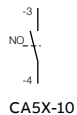
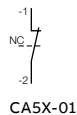

#### 2-pole auxiliary contacts

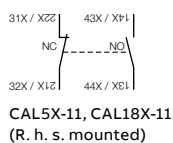
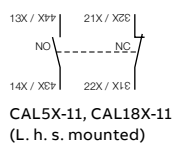

#### 4-pole auxiliary contacts

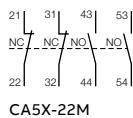
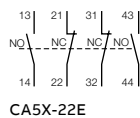

## Electronic timers



1SBC101396F01.4

TEF5-OFF

TEF5 frontal electronic timers are used for realizing timing function and are available in ON-delay and OFF-delay versions.

### Compact solution in cabinet compared to separate timers

TEF5 electronic timers are front-mounted and locked on AX contactors or NX contactor relays. A mechanical indicator allows to show the state of the contactor.

TEF5 electronic timers are supplied by direct wiring to the coil terminals A1 - A2 of the contactor or contactor relay. A varistor is integrated on the timer to offer a built-in protection against surges in the contactor coil.

### Available for a wide control voltage range 24...240 V AC / DC

TEF5-ON or TEF5-OFF allow time-delayed functions up to 100 s in 3 distinct time ranges, independently of the control system. The time delay ranges are selected by a switch and the time delay can be adjusted by means of a rotary switch. The timing function is activated by closing or opening the device on which the timer is mounted. The OFF-delay version operates without additional control supply.

For contactors, contactor relays	Time delay range selected by switch	Delay type	Rated control circuit voltage U <sub>c</sub> V 50/60 Hz or DC	Auxiliary contacts 	Type	Order code	Weight Pkg (1 pce) kg
AX09 ... AX80	0.1...1 s	ON-delay	24...240	1 1	TEF5-ON	1SBN020312R1000	0.065
NX 4-pole	1...10 s 10...100 s	OFF-delay	24...240	1 1	TEF5-OFF	1SBN020314R1000	0.065

# Electronic timers

## Technical data

### Contact utilization characteristics according to IEC

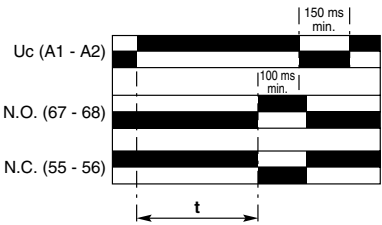
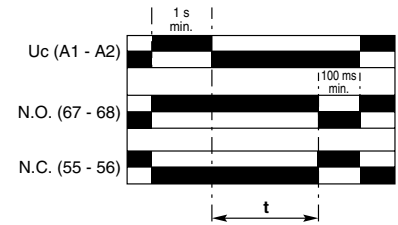
Types	TEF5-ON	TEF5-OFF
Standards	IEC 60947-5-1 and EN 60947-5-1	
Rated insulation voltage $U_i$ acc. to IEC 60947-5-1	400 V	
Rated impulse withstand voltage $U_{imp}$	4 kV	
Rated operational voltage $U_e$ max.	240 V	
Rated frequency (without derating)	50 / 60 Hz	
Conventional thermal current $I_{th} - \theta \leq 40^\circ\text{C}$	5 A	
$I_e$ / Rated operational current AC-15 acc. to IEC 60947-5-1	24-127 V 50/60 Hz 3 A	220-240 V 50/60 Hz 1.5 A
Making capacity	10 x $I_e$ AC-15 acc. to IEC 60947-5-1	
Breaking capacity	10 x $I_e$ AC-15 acc. to IEC 60947-5-1	
$I_e$ / Rated operational current DC-13 acc. to IEC 60947-5-1	24 V DC 1 A / 24 W	
Short-circuit protection device gG type fuse	6 A	
Rated short-time withstand current $I_{cw}$ $\theta = 40^\circ\text{C}$	for 1.0 s 8 A	for 0.1 s 8 A
Minimum switching capacity with failure rate acc. to IEC 60947-5-4	24 V DC 12 V / 3 mA	10 <sup>-7</sup>
Power dissipation per pole at 3 A	0.1 W	
Function diagram	ON-delay 	OFF-delay 
	Bistable relay inside. Before use, once apply $U_c$ then switch it off in order to initialize position of the contacts.	
Control circuit voltage		
AC control voltage	Rated control circuit voltage $U_c$ 50/60 Hz	24...240 V AC
	Average consumption	1.5 mA RMS
DC control voltage	Rated control circuit voltage $U_c$	24...240 V DC
	Average consumption	1.5 mA
Rated frequency limits	50 / 60 Hz	
Supply voltage range	0.85...1.1 x $U_c$ (at $\theta \leq 70^\circ\text{C}$ )	
Overvoltage protection	Varistor included	
Time delay range (t) selected by switch	0.1...1 s <input type="checkbox"/>	
	1...10 s <input type="checkbox"/>	
	10...100 s <input type="checkbox"/>	
On-load reiteration accuracy under constant conditions	$\leq 1\%$	
Minimum ON period	0.1 s	
Recovery time	0.15 s	0.1 s
Ambient air temperature Operation	-25 °C... +70 °C	
	Storage	-40 °C... +80 °C
Climatic withstand	Category B according to IEC 60947-1 Annex Q	
Maximum operating altitude	2000 m	
Mounting positions	Acc. to mounting positions permitted on contactors or contactor relays	
Shock withstand	1/2 sinusoidal shock for 11 ms: no change in contact position	
acc. to IEC 60068-2-27 and EN 60068-2-27 (Mounting position 1)	Same as contactor or contactor relay	
Mechanical durability		
	Number of operating cycles	5 millions operating cycles
	Max. switching frequency	3600 cycles/h
Max. electrical switching frequency	AC-15	1200 cycles/h
	DC-13	900 cycles/h







# Electronic timers

## Technical data

### Contact utilization characteristics according to UL / CSA

Types	TEF5-ON	TEF5-OFF
Standards	UL 508, CSA C22.2 N°14	
Rated insulation voltage Ui acc. to UL / CSA	300 V	
Max. operational voltage	240 V	
Pilot duty	B300, R300	
AC thermal rated current	5 A	
AC maximum volt-ampere making	3600 VA	
AC maximum volt-ampere breaking	360 VA	
DC thermal rated current	1 A	
DC maximum volt-ampere making-breaking	28 VA	

### Connecting characteristics

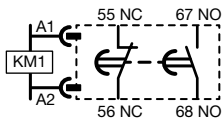
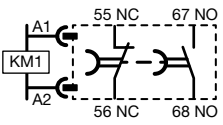
Connection capacity (min. ... max.)	
 Rigid solid	1 x 1...2.5 mm <sup>2</sup> 2 x 1...2.5 mm <sup>2</sup>
 Flexible with non insulated ferrule	1 x 0.75...2.5 mm <sup>2</sup> 2 x 0.75...2.5 mm <sup>2</sup>
 Flexible with insulated ferrule	1 x 0.75...2.5 mm <sup>2</sup> 2 x 0.75...1.5 mm <sup>2</sup>
 Lugs	L ≤ 8 mm l > 3.7 mm
Connection capacity acc. to UL / CSA	1 or 2 x AWG 18...14
Stripping length	10 mm
Tightening torque	1 N.m / 9 lb.in
Degree of protection acc. to IEC 60947-1 / EN 60947-1 and IEC 60529 / EN 60529	IP20
Screw terminals All terminals	Delivered in open position, screws of unused terminals should be tightened M3.5
Screwdriver type	Flat Ø 5.5 / Pozidriv 2
Terminal Marking	 

## Mechanical and electrical interlock units



1SBC580411F0301

VM300H

### Mechanical interlock units

The VM mechanical interlock units are designed for the interlocking of two AX contactors. When mounted between two contactors, the VM mechanical interlock unit prevents one of the contactors from closing as long as the other contactor is closed.

Left side contactor	Right side contactor	Mounting	Auxiliary contacts	Type	Order code	Pkg qty	Weight (1 pce)
							kg

### Mechanical interlock units for two horizontal mounted contactors (1)

AX09 ... AX40	AX09 ... AX40	Horizontal	- -	VM5-1	1SBN030100R1000	1	0.066
---------------	---------------	------------	-----	-------	-----------------	---	-------

### Mechanical interlock units for two vertical mounted contactors

Up contactor	Down contactor	Mounting	Auxiliary contacts	Type	Order code	Pkg qty	Weight (1 pce)
AX95 ... AX150	AX150 ... AX205	Vertical	- -	VM300V	1SFN034701R1000	1	0.150

### Mechanical and electrical interlock sets

The VM mechanical interlock units are designed for the interlocking of two AX contactors. When mounted between two contactors, the VM mechanical interlock unit prevents one of the contactors from closing as long as the other contactor is closed.

The VE units include 2 N.C. contacts for electrical interlocking function.



1SBC00095V0014

VE5-1

Left side contactor	Right side contactor	Mounting	Auxiliary contacts	Type	Order code	Pkg qty	Weight (1 pce)
							kg

### Mechanical interlock units for two horizontal mounted contactors

AX09 ... AX40	AX09 ... AX40	Horizontal	- 2	VE5-1	1SBN030110R1000	1	0.076
AX32 ... AX80	AX50 ... AX80	Horizontal	- 2	VE5-2	1SBN030210R1000	1	0.146
AX50 ... AX80	AX32 ... AX80	Horizontal	- 2	VE5-2	1SBN030210R1000	1	0.146
AX50 ... AX80	AX95 ... AX150	Horizontal	- 2	VE5-2 (2)	1SBN030210R1000	1	0.146
AX95 ... AX150	AX50 ... AX80	Horizontal	- 2	VE5-2 (2)	1SBN030210R1000	1	0.146
AX95 ... AX150	AX95 ... AX150	Horizontal	- 2	VE5-2	1SBN030210R1000	1	0.146

(1) Mechanical durability: VM5-1 = 5 millions cycles, VM300H = 1 million cycles.

VM19 = 0,5 million cycles, VM205/260 = 1 million cycles, VM300V = 1 million cycles.

(2) The combination of AX50 ... AX80 contactors interlocked with AX95 ... AX150 contactors cannot be mounted on symmetrical rail (75 mm, IEC/EN 60715).

# Mechanical and electrical interlock units

## Technical data



### Contact utilization characteristics according to IEC

Types	VE5-1	VE5-2
Standards	IEC 60947-5-1 and EN 60947-5-1	
Rated insulation voltage Ui acc. to IEC 60947-5-1	690 V	
Rated operational voltage Ue max.	24...690 V	
Conventional thermal current Ith - $\theta \leq 40^\circ\text{C}$	16 A	
Ie / Rated operational current AC-15 acc. to IEC 60947-5-1	24-127 V 50/60 Hz	6 A
	220-240 V 50/60 Hz	4 A
	380-440 V 50/60 Hz	3 A
	500-690 V 50/60 Hz	2 A
Making capacity	10 x Ie AC-15 acc. to IEC 60947-5-1	
Breaking capacity	10 x Ie AC-15 acc. to IEC 60947-5-1	
Ie / Rated operational current DC-13 acc. to IEC 60947-5-1	24 V DC	6 A
	48 V DC	2.8 A
	72 V DC	1 A
	125 V DC	0.55 A
	250 V DC	0.3 A
Short-circuit protection device - gG type fuse	10 A	
Rated short-time withstand current Icw $\theta = 40^\circ\text{C}$	for 1.0 s	100 A
	for 0.1 s	140 A
Power dissipation per pole at 6 A	0.15 W	
Mechanical durability	5 millions operating cycles	
Number of operating cycles	5 millions operating cycles	
Max. switching frequency	600 cycles/h	

### Utilization characteristics according to UL / CSA

Standards	UL 508, CSA C22.2 N°14
Max. operational voltage	600 V

### Connecting characteristics

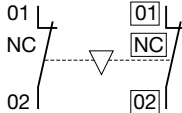
Connection capacity (min. ... max.)		
 Rigid solid	1 x	1...4 mm <sup>2</sup>
	2 x	1...4 mm <sup>2</sup>
 Flexible with ferrule	1 x	0.75...2.5 mm <sup>2</sup>
	2 x	0.75...2.5 mm <sup>2</sup>
 Lugs	L <	8 mm
	L >	3.5 mm
Tightening torque	Recommended	1 Nm
	Max.	1.2 Nm
Degree of protection acc. to IEC 60947-1 / EN 60947-1 and IEC 60529 / EN 60529	IP20	
Screw terminals All terminals	Delivered in open position, screws of unused terminals must be tightened M3.5	
Screwdriver type	Flat $\varnothing$ 5.5 / Pozidriv 2	
Terminal marking		

Technical note: when, during switching, the arc time is estimated to more than 40 ms, the closing signal of one of the two contactors must be delayed with respect to the opening signal of the other contactor in order to prevent a short-circuit.

## Interface relays



RA5-1

1SB-C10005F0014

RA5-1 interface relay is designed to receive 24 V DC signals delivered by PLC's or other sources with a low output power and to restore them with sufficient power to operate the coils of the relevant AX50, AX65 and AX80 contactors.

RA5-1 interface relay is made up of a miniature electromechanical relay equipped with a N.O. contact and with a low consumption 24 V DC coil.

The interface relay coil is controlled by the PLC while the N.O. contact ensures switching of the power contactor.

Coil switching gives rise to overvoltages which have adverse effects on the electronic devices, insulators and, more generally, on component lifetime. The RA5-1 is equipped with surge suppressors:

- on the 24 V DC relay coil via a diode,
- on the power contactor coil via a varistor.

Furthermore, the RA5-1 is protected against relay pole reversal by a diode inserted between the E1 and E2 input terminals.



For contactors	Coil voltages	Rated control circuit voltage Uc V DC	Type	Order code	Pkg qty	Weight (1 pce) kg
AX50 ... AX80	24...250	24	RA5-1	1SBN060300R1000	1	0.050
			RA5-1	1SBN060300T1000	10	0.050

# Interface relays

## Technical data

Type	<b>RA5-1</b>
<b>Utilization characteristics according to IEC</b>	
Standards	IEC 60255-5
Rated insulation voltage $U_i$ acc. to IEC 60947-4-1	250 V AC
Ambient air temperature	
In free air operation	at $U_c = 24$ V DC (between E1 and E2)
	from 0.85 to 1.1 x $U_c$
	-25...+70 °C
Storage	-25...+55 °C
	-40...+70 °C
Climatic withstand	Complies with that of associated contactors
Maximum operating altitude	3000 m
Mounting positions	No limitation
Fixing	Using the contactor A1 and A2 terminal connecting parts

### Connecting characteristics

Connection capacity (min. ... max.)	
 Rigid solid	1 x 1...4 mm <sup>2</sup>
	2 x 1...4 mm <sup>2</sup>
 Flexible with ferrule	1 x 0.75...2.5 mm <sup>2</sup>
	2 x 0.75...2.5 mm <sup>2</sup>
 Lugs	L < 8 mm
	l > 3.5 mm
Tightening torque	
Recommended	1 Nm
Max.	1.2 Nm
Degree of protection acc. to IEC 60947-1 / EN 60947-1 and IEC 60529 / EN 60529	Protection against direct contact in acc. with EN 50274 RA5-1 wired and mounted on the associated contactor
Screw terminals	Delivered in open position, screws of unused terminals must be tightened
All terminals	M3.5
Screwdriver type	Flat Ø 5.5 / Pozidriv 2

### Working data

Surge suppression	
For contactor coil	Varistor
For interface relay coil	Diode
Protection against polarity reversal between terminals E1 and E2	Diode
Interface relay operating time	Closing and drop-out ≤ 10 ms
Total operating time, interface relay + contactor	
Between energization and:	
N.O. contact closing	20...37 ms
N.C. contact opening	17...32 ms
Between de-energization and:	
N.O. contact opening	17...25 ms
N.C. contact closing	20...28 ms

### Electrical input data

Control voltage (E1 and E2 terminals) $U_c$	
Rated value	24 V DC
Max. range at ambient temperature 20 °C	19...30 V DC
Max. consumption for $U_c = 24$ V DC, $\theta = 20$ °C	0.3 W
"0" status (relay open)	for $U_c$ ≤ 2.4 V DC
	for $I_c$ < 1 mA
"1" status (relay closed)	for $U_c$ ≥ 19 V DC
Max. short supply interruption immunity time	2 ms

### Electrical output data

Switching voltage (A0 and A2 terminals)	≤ 250 V AC
Electrical durability	
Number of operating cycles	2 millions

### Connection

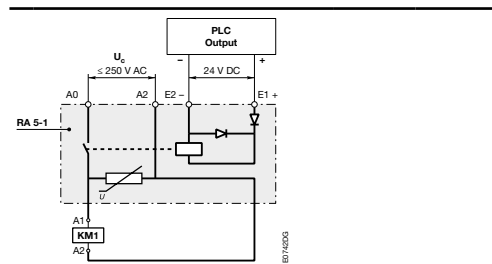

The "E1+" and "E2-" input terminals must be connected, according to their polarity, to the PLC output. The RA5-1 is equipped with two terminal pads for connection to the A1 and the A2 terminals of the contactor coil. This coil is supplied between the A0 and the A2 terminals of the RA 5-1. Mounting: terminals pads clamped inside the contactor coil terminals.

## Mechanical latching units



1SBC065483F03 01

WB75-A

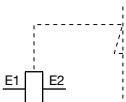

Terminal marking

For converting standard contactors into latched contactors.

The WB75-A block contains a mechanical latching device with electromagnetic impulse unlatching (AC or DC) or manual unlatching.

Captive screw type connecting terminals, built-in cable clamps, M3.5 (+,-) pozidriv 2 screw with screwdriver guidance; delivered untightened and protected against accidental direct contact.

### Operation

After closing, the contactor continues to be held in the closed position by the latching mechanism without supply voltage at the contactor coil terminals.

Contactor opening can be controlled:

- electrically by an impulse (AC or DC) on the WB75-A block coil.  
(the coil is not designed to be permanently energized)
- manually by pressing the pushbutton on the front face of the WB75-A block.



### Mounting

The WB75-A block is clipped onto the front face of the 1-stack contactor where it takes up two slots. The two other slots may accept CA5X single pole auxiliary contacts (1 block on each side of the mechanical latch).

For contactors	Rated control circuit voltage U <sub>c</sub>		Type	Order code	Pkg qty	Weight (1 pce) kg
	V 50 Hz or DC	V 60 Hz				
AX09 ... AX80	24	24...28	WB75-A	FPTN372726R1001	1	0.120
	42	42...48	WB75-A	FPTN372726R1002	1	0.120
	48	48...55	WB75-A	FPTN372726R1003	1	0.120
	110	110...127	WB75-A	FPTN372726R1004	1	0.120
	220...230	220...255	WB75-A	FPTN372726R1006	1	0.120
	230...240	230...277	WB75-A	FPTN372726R1005	1	0.120
	380...415	380...440	WB75-A	FPTN372726R1007	1	0.120
	415...440	440...480	WB75-A	FPTN372726R1008	1	0.120

## Mechanical latching units

### Technical data

Type	<b>WB75-A</b>	
<b>Utilization characteristics according to IEC</b>		
Rated insulation voltage $U_i$ acc. to IEC 60947-1	690 V	
Max. electrical impulse time		
On AC coil (with load factor 5 %)	20 s	
On DC coil (with load factor 3 %)	8 s	
Min. electrical impulse time		
For latching (energizing of the contactor coil)	AC	50 ms
For pull-out (energizing of the WB block coil)	AC	30 ms
Coil operating limits	AC or DC supply	0.85...1.1 x $U_c$
AC control voltage 50/60 Hz		
Rated control circuit voltage $U_c$	24...480 V AC	
Coil consumption	Average pull-in value	90 VA
	Average holding value	60 VA
DC control voltage		
Rated control circuit voltage $U_c$	24...440 V DC	
Coil consumption	Average pull-in value	110 W
	Average holding value	110 W
Operating time		
On contactor closing (latching)		
Between coil energization and:	N.O. contact closing	No difference with the operation of a contactor without mechanical latching unit
	N.C. contact opening	No difference with the operation of a contactor without mechanical latching unit
On contactor opening (unlatching)		
Between WB coil energization and:	N.O. contact opening	5...25 ms
	N.C. contact closing	7...28 ms
Mechanical durability		
Number of operating cycles	1 million operating cycles	
Max. switching frequency	3600 cycles/h with on-load factor of 8 %	
<b>Connecting characteristics</b>		
Connection capacity (min. ... max.)		
 Rigid solid	1 x	1...4 mm <sup>2</sup>
	2 x	1...4 mm <sup>2</sup>
 Flexible with ferrule	1 x	0.75...2.5 mm <sup>2</sup>
	2 x	0.75...2.5 mm <sup>2</sup>
 Lugs	L <	8 mm
	I >	3.5 mm
Tightening torque	Recommended	1 Nm
	Max.	1.2 Nm
Screw terminals	Delivered in open position, screws of unused terminals must be tightened	
All terminals	M3.5	
Screwdriver type	Flat Ø 5.5 / Pozidriv 2	

## Surge suppressors for contactor coils

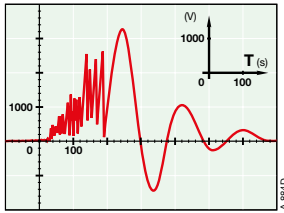

The operation of inductive circuits causes overvoltages, in particular on opening of the contactor coil.

The electromagnetic energy stored in the coil during contactor closing is restored on opening in the form of surges, the slope and amplitude of which may rise to several kilovolts. A number of drawbacks are observed ranging from interference on the electronic devices to breakdown of insulators and even destruction of certain sensitive components.

The graph opposite reproduces the oscillogram showing voltage discharges at the terminals of a 42 V / 50 Hz coil without peak clipping. The coil was switched by 8 series-connected poles of a contactor relay.

Following a burst of discharges with a very steep slope a damped oscillation emerges with a peak value of 3500 V.

### Overvoltage Factor

The overvoltage factor  $k$  is defined as the ratio of the maximum overvoltage peak value  $\hat{U}_s$  to the peak value  $\hat{U}_c$  of the coil rated control voltage  $U_c$ :

$$k = \frac{\hat{U}_s \text{ max.}}{\hat{U}_c} \quad \text{or in AC:} \quad k = \frac{\hat{U}_s \text{ max.}}{U_c \sqrt{2}}$$

For example the following is obtained for the above graph:  $k = \frac{3500}{42 \sqrt{2}} \approx 60$



To reduce the harmful effects of these overvoltages, ABB has developed a range of surge suppressors designed to reduce the  $k$  factor defined above and to limit or even completely eliminate the high pre-damping voltage frequencies.

Each case is different, but the technical data tolerances and the generous sizing of parts have enabled us to reduce the number of variants.

We have chosen the following solutions: varistors and RC blocks.

Note: A varistor is a resistor whose value decreases to a very large extent when a certain voltage is applied at its terminals.



For contactors	Rated control circuit voltage $U_c$ V AC	Type	Order code	Pkg qty	Weight (1 pce) kg
AX09 ... AX150	24...50	RV5/50	1SBN050010R1000	2	0.015
	50...133	RV5/133	1SBN050010R1001	2	0.015
	110...250	RV5/250	1SBN050010R1002	2	0.015
	250...440	RV5/440	1SBN050010R1003	2	0.015
AX09 ... AX40	24...50	RC5-1/50	1SBN050100R1000	2	0.012
	50...133	RC5-1/133	1SBN050100R1001	2	0.012
	110...250	RC5-1/250	1SBN050100R1002	2	0.012
	250...440	RC5-1/440	1SBN050100R1003	2	0.012
AX50 ... AX150	24...50	RC5-2/50	1SBN050200R1000	2	0.015
	50...133	RC5-2/133	1SBN050200R1001	2	0.015
	110...250	RC5-2/250	1SBN050200R1002	2	0.015
	250...440	RC5-2/440	1SBN050200R1003	2	0.015



## Surge suppressors for contactor coils

### Technical data

Varistor	RV5/50	RV5/133	RV5/250	RV5/440
Rated control circuit voltage $U_c$	24...50 V AC	50...133 V AC	110...250 V AC	250...440 V AC
Residual overvoltage (clipping voltage)	132 V AC	270 V AC	480 V AC	825 V AC
Opening time growth factor	1.1...1.5			
Operating temperature	-20...+70 °C			
Connection to the coil terminals (parallel mounting)	Clip-on for both fixing and connection.			
Fixing	Clipped onto the top part of the contactor base without change in contactor overall dimensions.			
Advantages	High energy absorption: good damping - Unpolarized system.			
Drawback	Clipping as from $U_{vdr}$ (1), thus voltage front up to this point.			

(1)  $U_{vdr}$  = Varistor operating voltage (voltage dependent resistor), tolerance  $\pm 10\%$ .

RC type	RC5-1/50	RC5-1/133	RC5-1/250	RC5-1/440
	RC5-2/50	RC5-2/133	RC5-2/250	RC5-2/440
Rated control circuit voltage $U_c$	24...50 V AC	50...133 V AC	110...250 V AC	250...440 V AC
Residual overvoltage (clipping voltage)	2 to 3 x $U_c$ max.			
Opening time growth factor	1.2...1.3			
Operating temperature	-20...+70 °C			
Connection to the coil terminals (parallel mounting)	Clip-on for both fixing and connection.			
Fixing	Clipped onto the top part of the contactor base without change in contactor overall dimensions.			
Advantages	Very fast clipping - Attenuation of steep fronts and thus of high frequencies. No operating delays.			

### Wiring diagrams

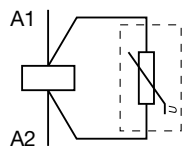

Varistor

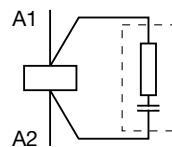

RC type

### Dimensions

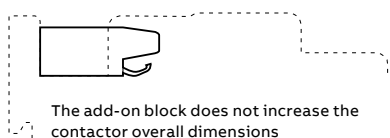

The add-on block does not increase the contactor overall dimensions

RV5, RC5

## Additional terminal blocks



LD75

1SBCC-880723F0301



LD110

1SBCC-880723F0301

The LD terminal block is designed to increase the connecting capacity of the contactor on which it is fitted and for preparation of the wiring before final connection on the contactor.







The LD blocks are 3-pole terminal blocks with tunnel terminals. The available range can be used on AX50 to AX150 contactors.

The LD75 and LD110 terminal blocks are fixed in the 3 independent slots located above the built-in connectors.

For contactors	Type	Order code	Pkg qty	Weight (1 pce) kg
AX50 ... AX80	LD75	1SBN073508R1000	1	0.115
AX95 ... AX150	LD110 (1)	1SFN074308R1000	1	0.150

(1) up to 160 AAC-1.

### Technical data

Types	LD75	LD110
Rated insulation voltage Ui acc. to IEC 60947-4-1 acc. to UL / CSA		
Main terminals	 Screw terminals with single connector 10 x 11 mm	 Screw terminals with single connector 12 x 12 mm
Connection capacity (min. ... max.)		
 Rigid Solid ( $\leq 4 \text{ mm}^2$ )	1 x 6...50 mm <sup>2</sup>	10...70 mm <sup>2</sup>
 Stranded ( $\geq 6 \text{ mm}^2$ )	2 x 6...25 mm <sup>2</sup>	10...35 mm <sup>2</sup>
 Flexible with ferrule	1 x 6...35 mm <sup>2</sup>	10...50 mm <sup>2</sup>
 Bars	2 x 6...16 mm <sup>2</sup>	10...25 mm <sup>2</sup>
Tightening torque	4 Nm	6 Nm
Degree of protection acc. to IEC 60947-1 / EN 60947-1 and IEC 60529 / EN 60529		
Screw terminals	M6	M8
Screwdriver type	Pozidriv 2	Hexagon socket (s = 4 mm)

Note: The utilization of LD additional terminal blocks keeps the possibility to connect the following cables directly in the contactor main terminals but the BED and BEM connecting sets can no longer be used.

	LD75	LD110
Possible cross section of rigid cable in the contactor terminals	50 mm <sup>2</sup>	95 mm <sup>2</sup>

## Function markers

### Terminals for control lead connections



BA5-50

1SBC575874FC901

#### Function markers AX09 ... AX150

Set of 50 function markers designed to be clipped onto the front face of devices. Details can be added to these markers using a ball point pen, indelible felt-tip pen or pentel white.

Self-adhesive labels (not supplied) can also be added to them.

Marker dimensions: 7 x 19 mm (0.276" x 0.748").

For contactors	Type	Order code	Pkg qty	Weight (1 pce) kg
AX09 ... AX150 and accessories	BA5-50	1SBN110000R1000	1	0.017



BA4

1SNC160101F0014

#### Terminals for control lead connections

Terminals designed to connect the control conductors to the main poles of the AX50 ... AX80 contactors.

Accessories clipped into the slots placed above each power terminal connector.

The LK75 are fitted with a pin designed to hold them in place until the connector has been fully clamped with its power cable.

- Degree of protection IP20
- Connecting terminal delivered in open position: cable clamp and M3.5 (+,-) pozidriv 2 screw.
- Cable cross-sectional area:
  - 1 or 2 rigid conductors 1...4 mm<sup>2</sup>
  - 1 or 2 flexible conductors with cable end 0.75...2.5 mm<sup>2</sup>
- Tightening torque for the LK screw:
  - recommended 1.00 Nm
  - maxi. 1.20 Nm



LK75-F

1SBC575779FC001

For contactors	Type	Order code	Pkg qty	Weight (1 pce) kg
AX50 ... AX80	LK75-F	1SBN073552R1002	2	0.006

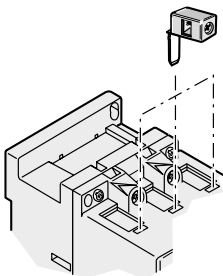

LK positioning

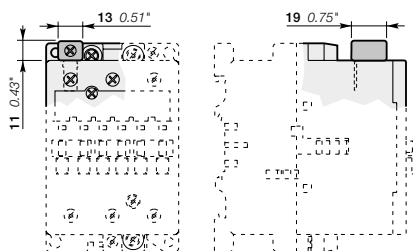

LK75-F

Main dimensions mm, inches

## Terminal connecting strips and shorting bars



LY16

15BC576832F0301

Parallel and series connection of 3-pole contactors:

- To obtain a star point (3 parallel-connected poles): LY allows 3 phases to be short-circuited.
- To connect poles in parallel and thus increase the AC load passing through the flow path made up of the parallel-connected poles: LP (2 poles); LY (3 poles).
- For the maximum permissible current values with parallel-connected poles see "Parallel connection of main poles".

The relevant cable cross-sectional area may limit the maximum permissible current. Consult information in table below.

- To connect poles in series and thus increase the DC load controlled by the poles: LP.

Types	for connection of "n" poles	with terminal	insulated
LP	n = 2	no	yes
LY	n = 3	no	yes

For contactors	max. nominal current with "n" poles A	continuous current mm <sup>2</sup>	Type	Order code	Pkg qty	Weight (1 pce) kg
AX09	30	6	LP16	FPEP407000R0001	10	0.002
AX12	32	6				
AX18	34	6				
NX	-	6				
AX09	33	6	LY16	FPEP407002R0001	10	0.005
AX12	36	6				
AX18	39	6				

## Connection accessories for starting solutions

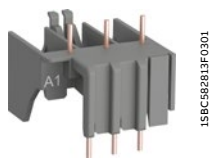

BEA

### Connection links between contactors and manual motor starters

The BEA connecting links are used to connect a contactor to associated manual motor starters. These are then used together as DOL or reversing starters in type 1 or type 2 coordination, complying with IEC 60947-4-1 and EN 60947-4-1.

The BEA insulated 3-pole connecting link (touch safe) ensures the electrical linking between the contactor and the corresponding manual motor starter.

For contactors	Manual motor starter	Type	Order code	Pkg qty	Weight (1 pce) kg
AX09 ... AX18	MS116-0.16 ... MS116-16	BEA16/116	1SBN081406R1000	10	0.020
AX25	MS116-0.16 ... MS116-16	BEA25/116	1SBN089306T1000	10	0.020
AX25	MS116-20 ... MS116-32	BEA25/132	1SBN089306T1001	10	0.020

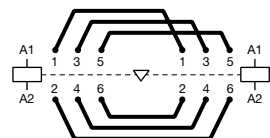

BEM ... connections

### Connection sets for reversing contactors

Connections between the main poles of two 3-pole contactors mounted side by side as reversing contactors with mechanical or electrical interlock.

The sets are made up of three upstream connections and three downstream connections.

- BER16V ... BER40V: Insulated, stranded, rigid copper wires
- BEM75-30 ... BEM110-30: Insulated, solid copper bars

On the AX contactors, the power supply by bars or cables equipped with lugs is directly connected to the terminal pads of the main poles. For flange connectors, LX terminal extension pieces should be used.

For contactors	Type	Order code	Pkg qty	Weight (1 pce) kg
AX09 ... AX18	BER16V	1SBN081411R1000	1	0.045
AX32, AX40	BER40V	1SBN082411R1000	1	0.085
AX50 ... AX80	BEM75-30	1SBN083501R1000	1	0.243
AX95 ... AX150	BEM110-30 (1)	1SBN084301R1000	1	0.450

(1) up to 160 A AC-1

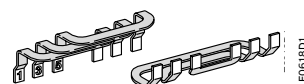

BEM 75-30

## Phase to phase connections

### Connection sets for star-delta starters

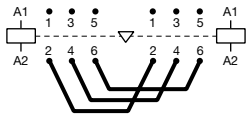

BEP, BES

#### Phase to phase connections

Connections between the main poles of two 3-pole contactors horizontal mounted.

This set is made up of three downstream or upstream connections.

For contactors	Type	Order code	Pkg qty	Weight (1 pce) kg
AX50 ... AX80	BES75-30	1SBN083504R1000	1	0.130
AX95 ... AX150	BES110 (1)	1SFN084304R1000	1	0.250

(1) up to 160 A AC-1.

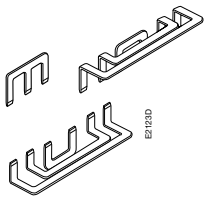

BED 110

#### Connections sets for star-delta starters

Connections between the main poles of a star-delta starter.

These sets are made up of:

- Three line contactor / delta contactor connections, upstream side
- Three connections for star and delta contactors, downstream side
- The necessary elements to create the star point upstream of the star contactor.
- Insulated, solid copper bars.

BED are designed for both star and delta contactors with or without mechanical interlock unit.

For line and delta contactors	For star contactors	Interlock unit between delta and star contactors	Type	Order code	Pkg qty	Weight (1 pce) kg
AX150	AX95	VE5-2	BED110 (1)	1SFN084503R1000	1	0.500

(1) up to 160 A AC-1.

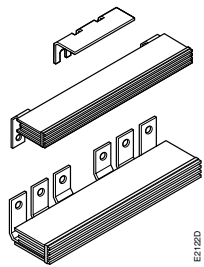

BED 185

## Voltage code table

The below tables indicate the available coil voltages and corresponding digits for order codes. When placing an order, please give the order code. Select a standard contactor from ordering detail pages. Change the coil voltage code in the order code according to the table below. Example: for contactor AX40-30-10 and coil 200 V 50 Hz, the order code is 1SBL321074R7510.

### AX contactors

**Order code**  
1SBL321074R **75** 10

**AC coil code**  
Contactors: AX

	50 Hz	60 Hz
<b>81</b>	24 V	24 V
26	105 V	110...127 V
<b>75</b>	<b>200 V</b>	<b>200...220 V</b>
85	380... <b>400 V</b>	<b>400...415 V</b>

**Codes in bold for dual frequency coils.**

**AC-3 Current rating**  
Contactor type  
AC operated

### NX contactor relays

**Order code**  
1SBH901074R **75** 40

**AC coil code**  
Contactors: NX

	50 Hz	60 Hz
<b>81</b>	24 V	24 V
26	105 V	110...127 V
<b>75</b>	<b>200 V</b>	<b>200...220 V</b>
85	380... <b>400 V</b>	<b>400...415 V</b>

**Codes in bold for dual frequency coils.**

**Contactor relay type**  
AC operated

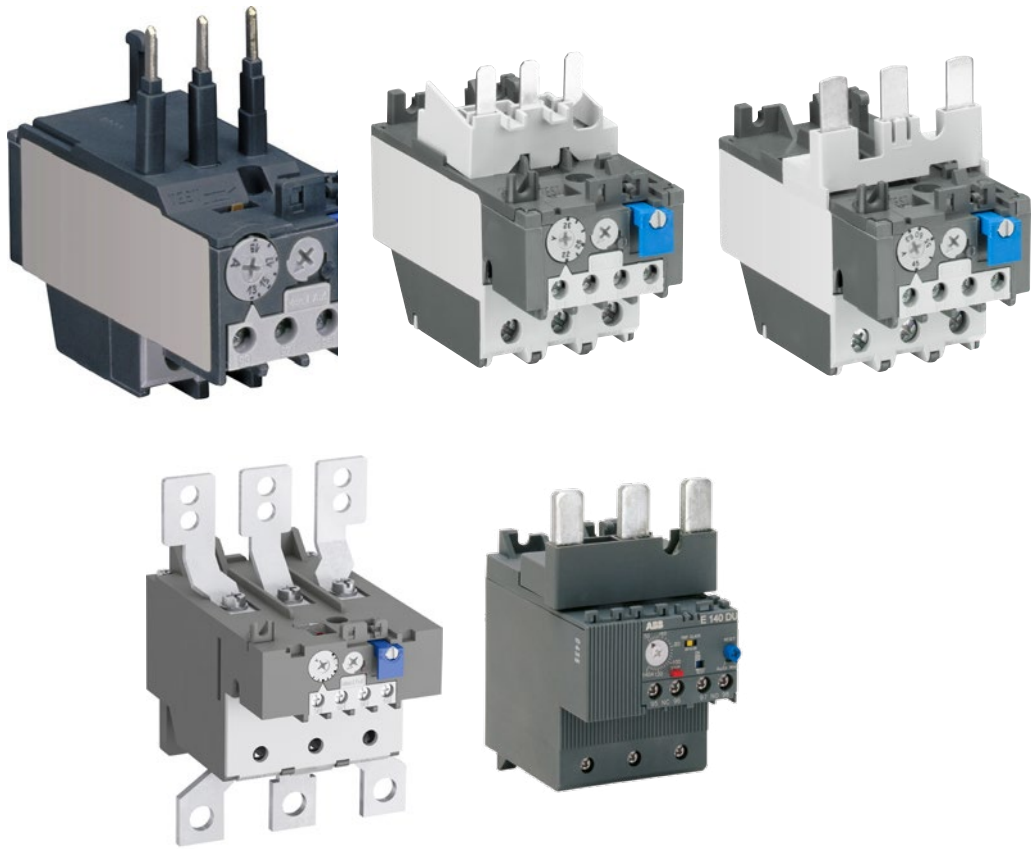



# Overload relays

	<b>Overview</b>
88	Thermal overload relays
	<b>TA25DU-M (0.10 ... 32 A)</b>
89	Ordering details
90	Technical data
93	Accessories
98	Dimensions
	<b>TA42DU-M (18 ... 42 A)</b>
89	Ordering details
90	Technical data
93	Accessories
98	Dimensions
	<b>TA75DU-M (18...80 A)</b>
89	Ordering details
90	Technical data
93	Accessories
98	Dimensions
	<b>TA80DU-M (29...80 A)</b>
94	Ordering details
95	Technical data
99	Dimensions
	<b>TA110DU-M (66 ... 110 A)</b>
94	Ordering details
95	Technical data
99	Dimensions

## Overload relays

### Thermal overload relay

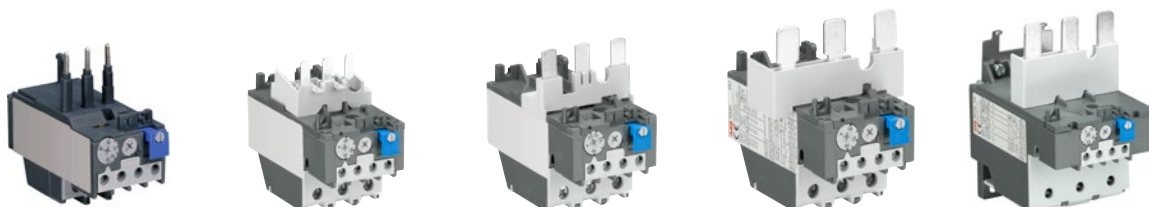

Type	TA25DU-M	TA42DU-M	TA75DU-M	TA80DU-M	TA110DU-M
Current range	0.10 ... 32 A	18 ... 42 A	18 ... 80 A	29 ... 80 A	66 ... 110 A
Trip class	10A	10A	10A	10A	10A
Single mounting kit	DB25	DB80	DB80	DB80	DB200
For contactors	AX09 ... AX40	AX32 ... AX40	AX50 ... AX80	AX95 ... AX150	AX95 ... AX150

## Thermal overload relays TA25DU-M / TA42DU-M / TA75DU-M

0.10 to 80 A



TA25DU-M



TA42DU-M

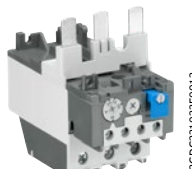

TA75DU-M

The TA25DU-M / TA42DU-M and TA75DU-M thermal overload relays are economic electromechanical protection devices for the main circuit. They offer reliable protection for motors in the event of overload or phase failure. The devices have trip class 10A.

The thermal overload relays are three pole relays with bimetal tripping elements. The motor current flows through the bimetal tripping elements and heats them directly and indirectly. In case of an overload (over current), the bimetal elements bent as a result of the heating. This leads to a release of the relay and a change of the contacts switching position (95-96 / 97-98).

- Manual or automatic reset selectable
- Phase loss sensitive acc. to IEC/EN 60947-4-1
- Two electrically isolated auxiliary contacts – 1 N.O. + 1 N.C.
- TEST and STOP function – Trip indication on the front
- Temperature compensation
- Suitable for three- and single-phase applications

Setting range	Short-circuit protective device	Trip class	Type	Order code	Weight (1 pce) kg
<b>A</b>					
<b>TA25DU-M</b>					
0.10 ... 0.16	0.50 A, Fuse type F	10A	TA25DU-0.16M	1SAZ211201R2005	0.150
0.16 ... 0.25	0.63 A, Fuse type F	10A	TA25DU-0.25M	1SAZ211201R2009	0.150
0.25 ... 0.40	1.25 A, Fuse type F	10A	TA25DU-0.4M	1SAZ211201R2013	0.150
0.40 ... 0.63	2 A, Fuse type gG / -	10A	TA25DU-0.63M	1SAZ211201R2017	0.150
0.63 ... 1.00	4 A, Fuse type gG / 2 A aM	10A	TA25DU-1.0M	1SAZ211201R2021	0.150
1.00 ... 1.40	6 A, Fuse type gG / 2 A aM	10A	TA25DU-1.4M	1SAZ211201R2023	0.150
1.30 ... 1.80	6 A, Fuse type gG / 4 A aM	10A	TA25DU-1.8M	1SAZ211201R2025	0.150
1.70 ... 2.40	6 A, Fuse type gG / 4 A aM	10A	TA25DU-2.4M	1SAZ211201R2028	0.150
2.20 ... 3.10	10 A, Fuse type gG / 6 A aM	10A	TA25DU-3.1M	1SAZ211201R2031	0.150
2.80 ... 4.00	10 A, Fuse type gG / 6 A aM	10A	TA25DU-4.0M	1SAZ211201R2033	0.150
3.50 ... 5.00	16 A, Fuse type gG / 10 A aM	10A	TA25DU-5.0M	1SAZ211201R2035	0.150
4.50 ... 6.50	20 A, Fuse type gG / 16 A aM	10A	TA25DU-6.5M	1SAZ211201R2038	0.150
6.00 ... 8.50	20 A, Fuse type gG / 20 A aM	10A	TA25DU-8.5M	1SAZ211201R2040	0.150
7.50 ... 11.00	35 A, Fuse type gG / 25 A aM	10A	TA25DU-11M	1SAZ211201R2043	0.150
10.00 ... 14.00	35 A, Fuse type gG / 25 A aM	10A	TA25DU-14M	1SAZ211201R2045	0.150
13.00 ... 19.00	50 A, Fuse type gG / 35 A aM	10A	TA25DU-19M	1SAZ211201R2047	0.170
18.00 ... 25.00	63 A, Fuse type gG / 50 A aM	10A	TA25DU-25M	1SAZ211201R2051	0.170
24.00 ... 32.00	80 A, Fuse type gG / 63 A aM	10A	TA25DU-32M	1SAZ211201R2053	0.200
<b>TA42DU-M</b>					
18 ... 25	63 A, Fuse type gG / 50 A aM	10A	TA42DU-25M	1SAZ311201R2001	0.335
22 ... 32	80 A, Fuse type gG / 63 A aM	10A	TA42DU-32M	1SAZ311201R2002	0.335
29 ... 42	100 A, Fuse type gG / 80 A aM	10A	TA42DU-42M	1SAZ311201R2003	0.335
<b>TA75DU-M</b>					
18 ... 25	63 A, Fuse type gG / 50 A aM	10A	TA75DU-25M	1SAZ321201R2001	0.335
22 ... 32	80 A, Fuse type gG / 63 A aM	10A	TA75DU-32M	1SAZ321201R2002	0.335
29 ... 42	100 A, Fuse type gG / 80 A aM	10A	TA75DU-42M	1SAZ321201R2003	0.335
36 ... 52	125 A, Fuse type gG / 100 A aM	10A	TA75DU-52M	1SAZ321201R2004	0.335
45 ... 63	160 A, Fuse type gG / 125 A aM	10A	TA75DU-63M	1SAZ321201R2005	0.335
60 ... 80	200 A, Fuse type gG / 160 A aM	10A	TA75DU-80M	1SAZ321201R2006	0.370

# Thermal overload relays TA25DU-M / TA42DU-M / TA75DU-M

## Technical data

### Main circuit – Utilization characteristics according to IEC/EN

Type	TA25DU-M	TA42DU-M	TA75DU-M
Standards	IEC/EN 60947-4-1, IEC/EN 60947-5-1, IEC/EN 60947-1		
Rated operational voltage Ue	690 V AC		
Rated frequency	DC, 50/60 Hz		
Frequency range	0 ... 400 Hz		
Trip class	10A		
Number of poles	3		
Duty time	100 %		
Operating frequency without early tripping	Up to 15 operations/h, see "Technical diagram – Intermittent periodic duty"		
Rated impulse withstand voltage Uimp	6 kV		
Rated insulation voltage Ui	690 V AC		

### Auxiliary circuit according to IEC/EN

Type	TA25DU-M	TA42DU-M	TA75DU-M
Rated operational voltage Ue	500 V AC, 440 V DC		
Conventional free air thermal current Ith	N.C., 95-96	10 A	
	N.O., 97-98	6 A	
Rated frequency	DC, 50/60 Hz		
Number of poles	1 N.O. + 1 N.C.		
Ie / Rated operational current AC-15 acc. to IEC/EN 60947-5-1 for utilization category			
110-120 V	N.C., 95-96	3.00 A	
	N.O., 97-98	1.50 A	
220-230-240 V	N.C., 95-96	3.00 A	
	N.O., 97-98	1.50 A	
440 V	N.C., 95-96	1.00 A	
	N.O., 97-98	1.00 A	
480-500 V	N.C., 95-96	1.00 A	
	N.O., 97-98	1.00 A	
Ie / Rated operational current DC-13 acc. to IEC/EN 60947-5-1 for utilization category			
24 V	N.C., 95-96	1.25 A	
	N.O., 97-98	1.25 A	
60 V	N.C., 95-96	0.25 A	
	N.O., 97-98	0.25 A	
110-120-125 V	N.C., 95-96	0.25 A	
	N.O., 97-98	0.25 A	
250 V	N.C., 95-96	0.12 A	
	N.O., 97-98	0.04 A	
Minimum switching capacity	17 V / 3 mA		
Short-circuit protective device	N.C., 95-96	10 A, Fuse type gG	
	N.O., 97-98	6 A, Fuse type gG	
Rated impulse withstand voltage Uimp	6 kV		
Rated insulation voltage Ui	690 V		

### Technical diagram – Intermittent periodic duty

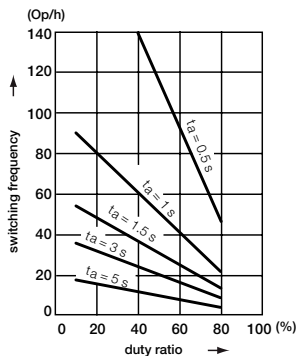

ta: Motor starting time - TA25DU-M, TA42DU-M, TA75DU-M

## Thermal overload relays TA25DU-M / TA42DU-M / TA75DU-M

### Technical data

#### Main circuit – Utilization characteristics according to UL/CSA

Type	TA25DU-M / TA42DU-M / TA75DU-M
Standards	UL 508, CSA 22.2 No. 14
Maximum operational voltage	600 V AC/DC
Trip rating	125 % of FLA
Full load amps (FLA)	See table "Full load amps and short-circuit protective device"
Short-circuit rating RMS symmetrical	See table "Full load amps and short-circuit protective device"
Short-circuit protective device	See table "Full load amps and short-circuit protective device"

#### Auxiliary circuit according to UL/CSA

Type	TA25DU-M / TA42DU-M / TA75DU-M
Contact rating	N.C., 95-96 B600 N.O., 97-98 C600
Conventional free-air thermal current	5 A

#### Full load amps and short-circuit protective device

Type	Full load amps (FLA)	Short-circuit protective device			
		480 / 600 V AC		480 / 600 V AC	
		Short circuit rating RMS symmetrical	Fuse K5 / RK5	Short circuit rating RMS symmetrical	Fuse J
TA25DU-0.16M	0.16 A	5000 A	1 A	50000 A	30 A
TA25DU-0.25M	0.25 A	5000 A	1 A	50000 A	30 A
TA25DU-0.4M	0.40 A	5000 A	3 A	50000 A	30 A
TA25DU-0.63M	0.63 A	5000 A	3 A	50000 A	30 A
TA25DU-1.0M	1.0 A	5000 A	6 A	50000 A	30 A
TA25DU-1.4M	1.4 A	5000 A	6 A	50000 A	30 A
TA25DU-1.8M	1.8 A	5000 A	6 A	50000 A	30 A
TA25DU-2.4M	2.4 A	5000 A	10 A	50000 A	30 A
TA25DU-3.1M	3.1 A	5000 A	10 A	50000 A	30 A
TA25DU-4.0M	4.0 A	5000 A	15 A	50000 A	30 A
TA25DU-5.0M	5.0 A	5000 A	20 A	50000 A	30 A
TA25DU-6.5M	6.5 A	5000 A	25 A	50000 A	30 A
TA25DU-8.5M	8.5 A	5000 A	35 A	50000 A	30 A
TA25DU-11M	11 A	5000 A	45 A	50000 A	35 A
TA25DU-14M	14 A	5000 A	60 A	50000 A	60 A
TA25DU-19M	19 A	5000 A	60 A	50000 A	60 A
TA25DU-25M	25 A	5000 A	70 A	50000 A	100 A
TA25DU-32M	32 A	5000 A	100 A	50000 A	100 A
TA42DU-25M	25 A	5000 A	80 A	50000 A	100 A
TA42DU-32M	32 A	5000 A	100 A	50000 A	100 A
TA42DU-42M	42 A	5000 A	150 A	50000 A	200 A
TA75DU-25M	25 A	5000 A	80 A	50000 A	100 A
TA75DU-32M	32 A	5000 A	100 A	50000 A	100 A
TA75DU-42M	42 A	5000 A	150 A	50000 A	200 A
TA75DU-52M	52 A	5000 A	175 A	50000 A	200 A
TA75DU-63M	63 A	10000 A	200 A	50000 A	200 A
TA75DU-80M	80 A	10000 A	250 A	50000 A	200 A



# Thermal overload relays TA25DU-M / TA42DU-M / TA75DU-M



## Technical data

### General technical data



Type	TA25DU-M	TA42DU-M	TA75DU-M
Pollution degree	3		
Phase loss sensitive	Yes		
Ambient air temperature			
Operation	Open - compensated	-25 ... +55 °C	
Storage	Open	-25 ... +55 °C	
Storage		-40 ... +70 °C	
Ambient air temperature compensation	Acc. to IEC/EN60947-4-1		
Maximum operating altitude permissible	2000 m		
Resistance to shock acc. to IEC 60068-2-27	12g / 15 ms		
Mounting position	Position 1-6		
Mounting	Mount on the contactor and tighten the screws of the main circuit terminals or with single mounting kit on DIN rail (35 mm)		
Degree of protection	Housing	IP20	
	Main circuit terminals	IP10	

### Electrical connection - main circuit

Type	TA25DU-M (0.16 ... 11 A)	TA25DU-M (14 ... 25 A)	TA25DU-M (32 A)
Connecting capacity			
 Rigid	1 x 0.75 ... 4 mm <sup>2</sup> 2 x 0.75 ... 4 mm <sup>2</sup>	1.5 ... 6 mm <sup>2</sup> 1.5 ... 6 mm <sup>2</sup>	1.5 ... 10 mm <sup>2</sup> -
 Flexible with ferrule	1 x or 2 x 0.75 ... 4 mm <sup>2</sup>	1.5 ... 4 mm <sup>2</sup>	1.5 ... 6 mm <sup>2</sup>
 Flexible	1 x or 2 x 0.75 ... 4 mm <sup>2</sup>	1.5 ... 4 mm <sup>2</sup>	1.5 ... 6 mm <sup>2</sup>
Stranded acc. to UL/CSA	1 x or 2 x AWG 16-8	AWG 16-8	AWG 10-8
Flexible acc. to UL/CSA	1 x or 2 x AWG 16-8	AWG 16-8	AWG 10-8
Stripping length	12 mm	12 mm	15 mm
Tightening torque	1.5 ... 1.9 Nm / 12 in-lb	1.5 ... 1.9 Nm / 12 in-lb	2.5 ... 3.2 Nm / 20 in-lb
Recommended screw driver	M4 (Pozidriv 2)	M4 (Pozidriv 2)	M5 (Pozidriv 2)

Type	TA42DU-M	TA75DU-M
Connecting capacity		
 Rigid	1 x 2.5 ... 25 mm <sup>2</sup> 2 x 2.5 ... 16 mm <sup>2</sup>	
 Flexible with ferrule	1 x 2.5 ... 25 mm <sup>2</sup> 2 x 2.5 ... 10 mm <sup>2</sup>	
Stranded acc. to UL/CSA	1 x or 2 x AWG 8-1	
Flexible acc. to UL/CSA	1 x or 2 x AWG 8-1	
Stripping length	14 mm	
Tightening torque	4.5 Nm / 40 in-lb	
Recommended screw driver	M6 (Pozidriv 2)	

### Auxiliary circuit

Type	TA25DU-M	TA42DU-M	TA75DU-M
Connecting capacity			
 Rigid	1 x or 2 x 0.75 ... 4 mm <sup>2</sup>		
 Flexible	1 x or 2 x 0.75 ... 2.5 mm <sup>2</sup>		
Stranded acc. to UL/CSA	1 x or 2 x AWG 18-14		
Flexible acc. to UL/CSA	1 x or 2 x AWG 18-14		
Stripping length	9 mm		
Tightening torque	1 ... 1.3 Nm / 12 in-lb		
Recommended screw driver	M3.5 (Pozidriv 2)		

# Thermal overload relays TA25DU-M / TA42DU-M / TA75DU-M

## Accessories

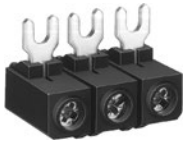

DX25

5ST01494

The single mounting kits offer the possibility to mount the overload relays separately from the contactor.

For thermal overload relays	Description	Type	Order code	Weight (1 pce) kg
-----------------------------	-------------	------	------------	-------------------

### Terminal block and mounting kits

TA25DU-0.16M; ... 25M / DB25/25 A	Terminal block 10 mm <sup>2</sup>	DX25	1SAZ201307R0002	0.030
TA25DU-0.16M ... 25M	Single mounting kit	DB25/25A	1SAZ201108R0001	0.055
TA25DU-32M	Single mounting kit	DB25/32A	1SAZ201108R0002	0.080
TA42DU-M / TA75DU-M	Single mounting kit	DB80	1SAZ301110R0001	0.155

### Reset push button

TA25DU-M / TA42DU -M / TA75DU -M	Reset push button*	KPR-101L	1SFA616162R1014	0.027
----------------------------------	--------------------	----------	-----------------	-------

\* The remote reset coil is to be connected to auxiliary contact 97-98 of TA25DU-M.  
The coil is not suitable for continuous operation. Impulse duration: maximum 0.2 seconds.



DB25/25A

2CDC231017F0006



KPR-101L

1SFC151409F0001



DB80

2CDC231007F0000

## Thermal overload relays TA80DU-M / TA110DU-M

29 to 110 A



TA80DU-M

2CDC3100BF0011



TA110DU-M

1100560001E2E20011



DB80

2CDC23100750010



KPR-101L

1SFCL51402F0010

The TA80DU-M and TA110DU-M thermal overload relays are economic electromechanical protection devices for the main circuit. They offer reliable protection for motors in the event of overload or phase failure. The devices have trip class 10A.

The thermal overload relays are three pole relays with bimetal tripping elements. The motor current flows through the bimetal tripping elements and heats them directly and indirectly. In case of an overload (over current), the bimetal elements bent as a result of the heating. This leads to a release of the relay and a change of the contacts switching position (95-96 / 97-98).

- Manual or automatic reset selectable
- Phase loss sensitive acc. to IEC/EN 60947-4-1
- Two electrically isolated auxiliary contacts – 1 N.O. + 1 N.C.
- TEST and STOP function – Trip indication on the front
- Temperature compensation
- Suitable for three- and single-phase applications

Setting range	Short-circuit protective device	Trip class	Type	Order code	Weight (1 pce) kg
A					
<b>TA80DU-M</b>					
29 ... 42	100 A, Fuse type gG / 80 A aM	10A	TA80DU-42M	1SAZ331201R2003	0.360
36 ... 52	125 A, Fuse type gG / 100 A aM	10A	TA80DU-52M	1SAZ331201R2004	0.365
45 ... 63	160 A, Fuse type gG / 125 A aM	10A	TA80DU-63M	1SAZ331201R2005	0.365
60 ... 80	200 A, Fuse type gG / 160 A aM	10A	TA80DU-80M	1SAZ331201R2006	0.375
<b>TA110DU-M</b>					
66 ... 90	200 A, Fuse type gG / 160 A aM	10A	TA110DU-90M	1SAZ411201R2001	0.750
80 ... 110	224 A, Fuse type gG / 200 A aM	10A	TA110DU-110M	1SAZ411201R2002	0.755

### Ordering details accessories

For thermal overload relays	Description	Type	Order code	Weight (1 pce) kg
TA80DU-M	Single mounting kit	DB80	1SAZ301110R0001	0.155
TA110DU-M	Single mounting kit	DB200	1SAZ401110R0001	0.225
TA80DU-M / TA110DU-M	Reset push button	KPR-101L	1SFA616162R1014	0.027



# Thermal overload relays TA80DU-M / TA110DU-M

## Technical data

### Main circuit – Utilization characteristics according to IEC/EN

Type	TA80DU-M	TA110DU-M
Standards	IEC 60947-1 / 60947-4-1 and EN 60947-1 / 60947-4-1	
Rated operational voltage Ue	690 V AC	
Rated frequency	DC, 50/60 Hz	
Frequency range	0 ... 400 Hz	
Trip class	10A	
Number of poles	3	
Duty time	100 %	
Operating frequency without early tripping	Up to 15 operations/h, see "Technical diagram – Intermittent periodic duty"	
Rated impulse withstand voltage Uimp	6 kV	
Rated insulation voltage Ui	690 V AC	

### Auxiliary circuit according to IEC/EN

Type	TA80DU-M	TA110DU-M
Rated operational voltage Ue	500 V AC, 440 V DC	
Conventional free air thermal current Ith	N.C., 95-96	10 A
	N.O., 97-98	6 A
Rated frequency	DC, 50/60 Hz	
Number of poles	1 N.O. + 1 N.C.	
Ie / Rated operational current AC-15 acc. to IEC/EN 60947-5-1 for utilization category		
110-120 V	N.C., 95-96	3.00 A
	N.O., 97-98	1.50 A
220-230-240 V	N.C., 95-96	3.00 A
	N.O., 97-98	1.50 A
440 V	N.C., 95-96	1.00 A
	N.O., 97-98	1.00 A
480-500 V	N.C., 95-96	1.00 A
	N.O., 97-98	1.00 A
Ie / Rated operational current DC-13 acc. to IEC/EN 60947-5-1 for utilization category		
24 V	N.C., 95-96	1.25 A
	N.O., 97-98	1.25 A
60 V	N.C., 95-96	0.25 A
	N.O., 97-98	0.25 A
110-120-125 V	N.C., 95-96	0.25 A
	N.O., 97-98	0.25 A
250 V	N.C., 95-96	0.12 A
	N.O., 97-98	0.04 A
Minimum switching capacity	17 V / 3 mA	
Short-circuit protective device	N.C., 95-96	10 A, Fuse type gG
	N.O., 97-98	6 A, Fuse type gG
Rated impulse withstand voltage Uimp	6 kV	
Rated insulation voltage Ui	690 V	

### Technical diagram – Intermittent periodic duty

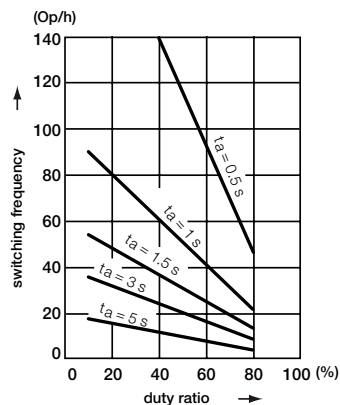

ta: Motor starting time - TA80DU-M, TA110DU-M

## Thermal overload relays TA80DU-M / TA110DU-M

### Technical data

#### Main circuit – Utilization characteristics according to UL/CSA

Type	TA80DU-M	TA110DU-M
Standards	UL 508, CSA 22.2 No. 14	
Maximum operational voltage	600 V AC/DC	
Trip rating	125 % of FLA	
Full load amps (FLA)	See table "Full load amps and short-circuit protective device"	
Short-circuit rating RMS symmetrical	See table "Full load amps and short-circuit protective device"	
Short-circuit protective device	See table "Full load amps and short-circuit protective device"	

#### Auxiliary circuit according to UL/CSA

Type	TA80DU-M / TA110DU-M	
Contact rating	N.C., 95-96	B600
	N.O., 97-98	C600
Conventional free-air thermal current	5 A	

#### Full load amps and short-circuit protective device

Type	Full load amps (FLA)	Short-circuit protective device			
		480 / 600 V AC		480 / 600 V AC	
		Short circuit rating RMS symmetrical	Fuse K5 / RK5	Short circuit rating RMS symmetrical	Fuse J
TA80DU-42M	42 A	5000 A	150 A	50000 A	200 A
TA80DU-52M	52 A	5000 A	175 A	50000 A	200 A
TA80DU-63M	63 A	10000 A	200 A	50000 A	200 A
TA80DU-80M	80 A	10000 A	250 A	50000 A	200 A
TA110DU-90M	90 A	10000 A	250 A	65000 A	200 A
TA110DU-110M	110 A	10000 A	250 A	65000 A	200 A



## Thermal overload relays TA80DU-M / TA110DU-M

### Technical data



#### General technical data

Type	TA80DU-M	TA110DU-M
Pollution degree	3	
Phase loss sensitive	Yes	
Ambient air temperature		
Operation		
Open - compensated	-25 ... +55 °C	
Open	-25 ... +55 °C	
Storage	-40 ... +70 °C	
Ambient air temperature compensation	Acc. to IEC/EN60947-4-1	
Maximum operating altitude permissible	2000 m	
Resistance to shock acc. to IEC 60068-2-27	12g / 15 ms	
Mounting position	Position 1-6	
Mounting	Mount on the contactor and tighten the screws of the main circuit terminals or with single mounting kit	
Degree of protection		
Housing	IP20	
Main circuit terminals	IP10	

#### Electrical connection - Main circuit

Type	TA80DU-M	TA110DU-M
Connecting capacity		
 Rigid	1 x 2.5 ... 25 mm <sup>2</sup> 2 x 2.5 ... 16 mm <sup>2</sup>	16 ... 35 mm <sup>2</sup> -
 Flexible with ferrule	1 x 2.5 ... 25 mm <sup>2</sup> 2 x 2.5 ... 10 mm <sup>2</sup>	16 ... 35 mm <sup>2</sup> -
 Lugs	-	-
Stranded acc. to UL/CSA	1 x or 2 x AWG 8-1	AWG 6-2/0
Flexible acc. to UL/CSA	1 x or 2 x AWG 8-1	AWG 6-2/0
Stripping length	14 mm	25 mm
Tightening torque	4.5 Nm / 40 lb.in	7.2 ... 9.6 Nm
Recommended screw driver	M6 (Pozi driv 2)	M8 (Hexagon 4)

#### Auxiliary circuit

Type	TA80DU-M	TA110DU-M
Connecting capacity		
 Rigid	1 x or 2 x 0.75 ... 4 mm <sup>2</sup>	
 Flexible with ferrule	1 x or 2 x 0.75 ... 2.5 mm <sup>2</sup>	
 Flexible	1 x or 2 x 0.75 ... 2.5 mm <sup>2</sup>	
Stranded acc. to UL/CSA	1 x or 2 x AWG 18-14	
Flexible acc. to UL/CSA	1 x or 2 x AWG 18-14	
Stripping length	9 mm	
Tightening torque	1 ... 1.3 Nm / 12 lb.in	
Recommended screw driver	M3.5 (Pozi driv 2)	

# Thermal overload relays TA25DU-M / TA42DU-M / TA75DU-M

## Dimensions

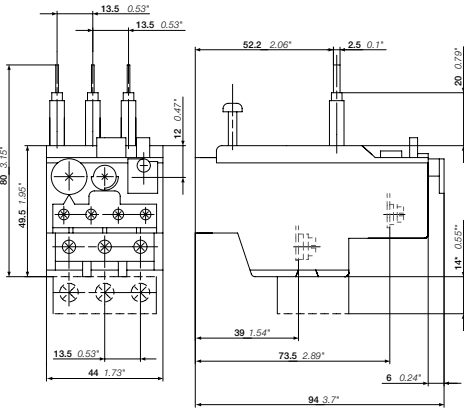

TA25DU-M + DX25

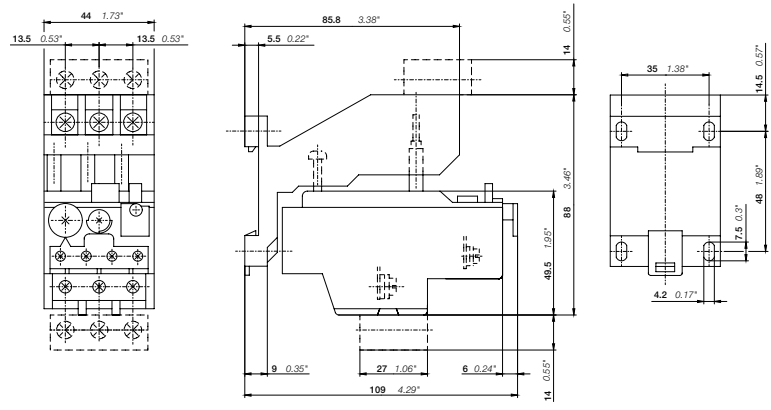

TA25DU-M + DB25 + DX25

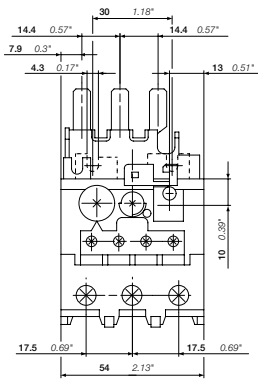

TA42DU-M

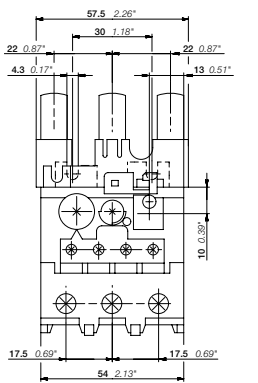

TA75DU-M

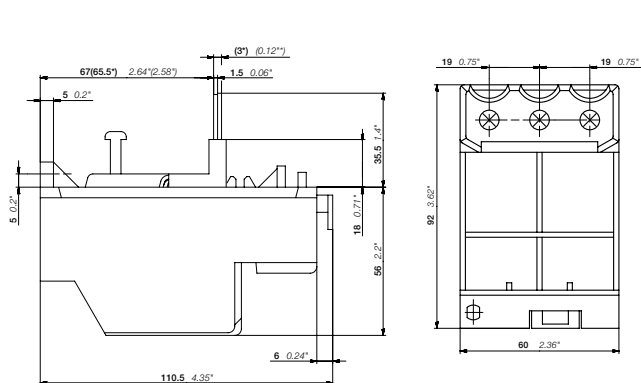

TA75DU-M + DB80  
TA42DU-M + DB80

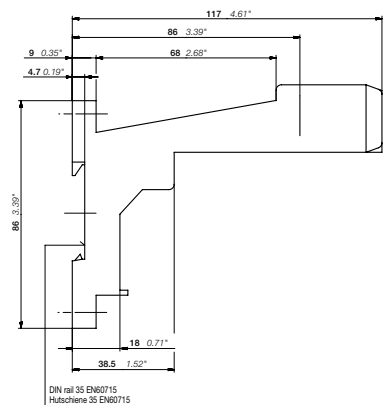

DIN rail 35 EN60715  
Hutschiene 35 EN60715

# Thermal overload relays TA80DU-M / TA110DU-M

## Dimensions

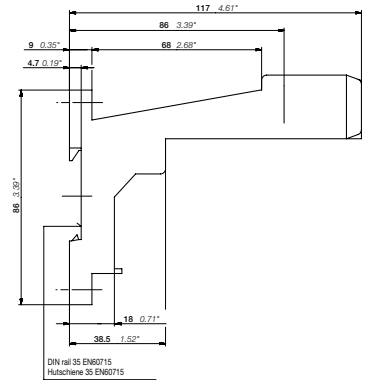
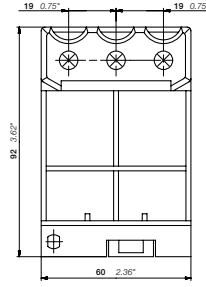
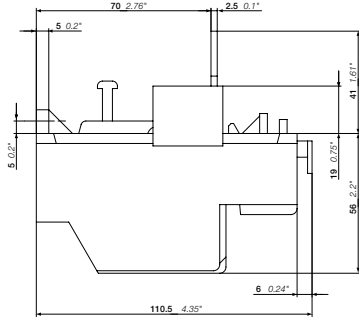
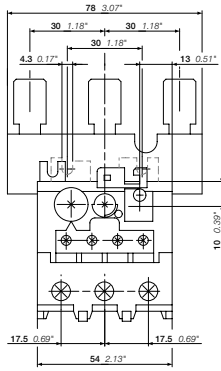

TA80DU-M

TA80DU-M + DB80

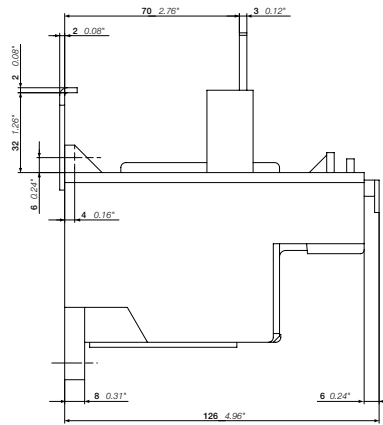
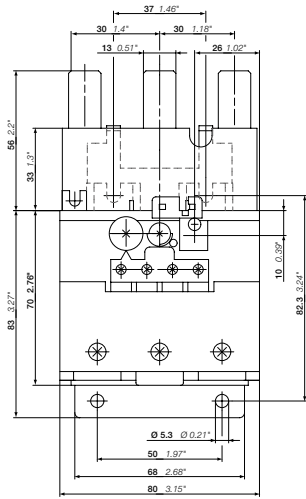

TA110DU-M



---

# General technical data

102	<b>Coordination with short-circuit protection devices</b>
103	<b>Terms and technical definitions</b>
105	<b>Standards and utilization categories</b>
107	<b>Degrees of protection</b>

## Coordination with short-circuit protection devices

In compliance with standards IEC 60947-4-1 and EN 60947-4-1, we define for the contactors and starters the type, rating and characteristics of the short-circuit protection devices SCPD which allow selective protection against overloads and ensure protection against short circuits.

### Basic functions

Any starter is designed to:

- start motors,
- ensure continuous functioning of motors,
- disconnect motors from the supply line,
- guarantee protection of motors against overloads.

The starter is typically made up of a switching device (contactor) and an overload protection device (thermal overload relay or electronic overload relay).

These two devices MUST be coordinated with equipment capable of providing protection against short circuit (SCPD: short circuit protective device): typically a circuit breaker with magnetic release only or a switch fuse. These are not necessarily part of the starter.

### Applicable standards

IEC 60947-4-1 (EN 60947-4-1) and UL 60947-4-1 between the branch circuit protective device and the motor starter precisely defines the different points to be considered in order to carry out correct coordination.

Complete coordination for a combination includes the following points:

- Selectivity test between the overload relay and the short-circuit protection device SCPD.
- Short-circuit condition tests:
  - at prospective "r" currents - These currents depend on the rated operational current of the starter (I<sub>e</sub> AC-3) and are given by the standard (Table 13). For example:
    - r = 1kA for I<sub>e</sub> AC-3 < 16 A
    - r = 3 kA for 16 A < I<sub>e</sub> AC-3 < 63 A
    - r = 5 kA for 63 A < I<sub>e</sub> AC-3 < 125 A etc.
  - at the rated conditional short-circuit current "I<sub>q</sub>" - This is the maximum prospective current that the combination can withstand, for example 50 kA.

### Types of coordination

IEC 60947-4-1 (EN 60947-4-1) UL 60947-4-1 between the branch circuit protective device and the motor starter defines two types of coordination according to the expected level of service continuity. Acceptable extreme damage for the switchgear is divided into two types.

- Type 1: In short-circuit conditions, the contactor or starter does not endanger persons or installations and will not be able to then operate without being repaired or having parts replaced.
- Type 2: In short-circuit conditions, the contactor or starter does not endanger persons or installations and will be able to operate afterwards. The risk of contacts light welding is acceptable. In this case, the manufacturer must stipulate the measures to be taken with respect to maintenance of the equipment.

### The complete ABB offer

ABB has acquired years of experience with respect to problems of coordination and is able to make a complete offer based on tests performed in its qualified laboratories.

This offer includes 400 V, 500 V, 690 V networks.

**A complete data base of coordination tables**, according to IEC 60947-4-1 (EN 60947-4-1), is available on the ABB Website.

In the coordination tables the following short-circuit protection devices are recommended:

- Moulded case circuit-breakers (MCCBs)
- Miniature circuit-breakers (MCBs)
- Switch-disconnector-fuses (aM, gG and BS)
- Manual Motor Starters (MMS).

### General remarks applicable to all tables

- Each table is defined for a maximum ambient temperature of 40 °C. For higher temperatures, apply a derating factor according to the following rules:
  - Fuses: factor of 0.8 applied to I<sub>n</sub> for an ambient temperature of 70 °C
  - MCCBs and MCBs: factor of 0.8 applied to I<sub>n</sub> for an ambient temperature of 60 °C
  - The starter derating factor depends on the operating conditions of thermal overload relays:
    - Factor of 0.9 applied to I<sub>n</sub> for an ambient temperature of 70 °C.
  - Each table is defined for motor currents: 3-phase motors, 4-pole
  - **Normal starting** means a starting time < 2 s.
  - **Difficult starting** means an accelerating time 10 s < t<sub>s</sub> < 30 s
    - Tripping classes of thermal overload relays according to IEC 60947-4-1 (EN 60947-4-1): 10A and 10
    - Tripping classes of electronic overload relays according to IEC 60947-4-1 (EN 60947-4-1): 10E, 20E, 30E selectable
  - In the tables with MCCBs, these are fitted with the magnetic relay alone. Setting is always carried out at > 12.3 I<sub>e</sub> AC-3 so that the transient current peak occurring during starting does not lead to tripping.



## Terms and technical definitions

### Circuits

- auxiliary circuit: All the conductive parts of a contactor designed to be inserted in a different circuit from the main circuit and the contactor control circuits.
- control circuit: All the conductive parts of a contactor (other than the main circuit and the auxiliary circuit) used to control the contactor's closing operation or opening operation or both.
- main circuit: All the conductive parts of a contactor designed to be inserted in the circuit that it controls.

### Thermal overload relay tripping classes

IEC 60947-4-1 defines tripping classes 10 A, 10, 20 and 30. Types 10 A, 10, etc. correspond to the maximum tripping time for a making current at 7.2 times the setting current. Furthermore, for each class the standard specifies the tripping time for 1.5 times the setting current and sets the non tripping condition at 1.05 times the setting current. All these data are summarized in the table below.

#### Extract from IEC 60947-4-1:

Tripping class		10 A	10	20	30
Max. tripping time for 1.5 times the setting current (warm state)	s	120	240	480	720
Tripping time for 7.2 times the setting current (cold state)	s	2 - 10	4 - 10	6 - 20	9 - 30
For 1.05 times the setting current		No tripping			

### Coordination of protections against short circuit

The goal here is to protect electromechanical starters and softstarters.

Any starter is designed to:

- start motors,
- ensure continuous functioning of motors,
- disconnect motors from the supply line,
- guarantee protection of motors against overloads.

The starter is typically made up of a switching device (contactor) and an overload protection device (thermal overload relay or electronic overload relay). These two devices MUST be coordinated with equipment capable of providing protection against short circuit (SCPD: short circuit protective device): typically a circuit breaker with magnetic release only or a switch fuse. These are not necessarily part of the starter.

The characteristics of the starter must comply with the international standard IEC 60947-4-1 which defines the above items as follows:

**contactor:** a mechanical switching device having only one position of rest, operated otherwise than by hand, capable of making, carrying and breaking currents under normal circuit conditions including overload conditions.

**overload release:** overload relay or release which operates in the case of overload and also in case of loss of phase.

**circuit-breaker:** defined by IEC 60947-2 as a mechanical switching device, capable of making, carrying and breaking currents under normal circuit conditions and also making, carrying for a specified time and breaking currents under specified abnormal circuit conditions.

IEC publication 60947-4-1 defines coordination types "1" and "2":

- Type "1" coordination requires that, in the event of a short-circuit, the contactor or starter does not endanger persons or installations and will not then be able to operate without being repaired or parts being replaced.
- Type "2" coordination requires that, in short-circuit conditions, the contactor or starter does not endanger persons or installations and will be able to operate afterwards. The risk of contacts being light welded is acceptable. In this case, the manufacturer must stipulate the measures to be taken with respect to maintenance of the equipment.

### Rated operational current $I_e$ .

Current rated by the manufacturer. It is mainly based on the rated operational voltage  $U_e$ , the rated frequency, the utilization category, the rated duty and the type of protective enclosure, if necessary.

### Conventional free air thermal current $I_{th}$

Current that the contactor can withstand in free air for a duty time of 8 hours without the temperature rise of its various parts exceeding the maximum values given by the standard.

### Operating cycle or cycle

Includes one making operation and one breaking operation.

### Cycle time

This is the sum of the current flow time and the no-current time for given cycle.

## Terms and technical definitions

### Electrical durability

Number of on-load operating cycles that the contactor is able to carry out. It depends on the operational current, the operational voltage and the utilization category.

### Mechanical durability

Number of no-current operating cycles that a contactor is able to carry out.

### Assessed failure rate

Defined according to IEC 60947-5-4. This rate is given in standard industrial environments for the contactor relays and for the built-in auxiliary contact of contactors.

### Load factor

Ratio of the on-load operating time to the total cycle time x 100.

### Switching frequency

Number of switching cycles per hour.

### Plugging

Stopping or fast reversal in rotation direction of a motor by two supply leads being interchanged while the motor is running.

### Inching

Energization of a motor's circuit repeatedly or for short periods with the aim of obtaining small movements of the driven mechanism.

### Coil operating limits

Expressed in multiples of the nominal control circuit voltage  $U_c$  for the upper and lower limits.

### Mounting position

Comply with the manufacturer's instructions. Restrictions are to be taken into account for certain mounting positions.

### Rated breaking or making capacity

Root mean square (r.m.s.) value of the current that the contactor is able to break or make at a given voltage according to the conditions specified by standards and for a given utilization category.

### Intermittent duty

Duty during which the contactor is successively closed or open for periods which are too short to enable the contactor to achieve thermal balance.

### Ambient temperature

Air temperature close to the contactor.

### Time

- Time constant: Ratio of the inductance to the resistance ( $L/R = \text{mH}/\Omega = \text{ms}$ ).
- Short-time withstand current: Current that the contactor is able to withstand in closed position for a short time interval and in specified conditions.
- Closing time: Time interval between the coil energization and the instant the contacts touch on all the poles.
- Opening time: Time interval between the coil de-energization and the instant the contacts separate on all the poles.

### Rated control voltage $U_c$

Control voltage value for which the control circuit is sized.

### Rated operational voltage $U_e$

Voltage to which the contactor's utilization characteristics refer. In three-phase it is the phase-to-phase voltage.

### Rated insulation voltage $U_i$

Reference voltage for dielectric tests and creepage distances.

### Rated impulse withstand voltage $U_{imp}$

Peak value of an impulse voltage, having a specified form and polarity, which does not cause breakdown in specific test conditions.

### Shock withstand

Requirement for vehicles, crane drives, installations on board ships and plug-in equipment. For the acceptable "g" values, the contacts must not change position and the thermal overload relays must not trip.

### Resistance to vibrations

Requirements for vehicles, boats and other means of transport. For the specified vibration amplitude and frequency values the device must remain able to operate.

## Standards and utilization categories

### Utilization categories:

A contactor's duty is characterised by the utilization category together with the rated operational voltage and current indicated.

#### Utilization categories for contactors according to IEC 60947-4-1:

Alternating current:	AC-1	Non-inductive or slightly inductive loads, resistance furnaces.
	AC-2	Slip-ring motors: starting, switching off.
	AC-3	Cage motors: starting, switching off running motors.
	AC-4	Cage motors: starting, plugging, inching.
	AC-5a	Discharge lamp switching.
	AC-5b	Incandescent lamp switching.
	AC-6a	Transformer switching.
	AC-6b	Capacitor bank switching.
		AC-8a
	AC-8b	Hermetic refrigeration compressor motor control with automatic resetting of overload releases.
Direct current:	DC-1	Non inductive or slightly inductive loads, resistance furnaces.
	DC-3	Shunt motors: starting, plugging, inching, dynamic breaking of DC motors.
	DC-5	Series motors: starting, plugging, inching, dynamic breaking of DC motors.
	DC-6	Incandescent lamp switching.

#### Utilization categories for contactor relays according to IEC 60947-5-1:

Alternating current:	AC-12	Control of resistive loads and static loads with opto-coupler isolation.
	AC-13	Control of static loads with transformer isolation.
	AC-14	Control of weak electromagnetic loads ( $\leq 72$ VA).
	AC-15	Control of electromagnetic loads ( $> 72$ VA).
Direct current:	DC-12	Control of resistive loads and static loads with opto-coupler isolation.
	DC-13	Control of DC electromagnets.
	DC-14	Control of DC electromagnets having economy resistors.

In fact some applications, and the specific criteria characterizing the various loads controlled by contactors, may modify the utilization characteristics of the contactors. The main applications concerned are:

#### Capacitor bank switching

Account must be taken of high peaks when the current is made and of harmonic currents during continuous duty. For this application, IEC publication 60947-4-1 stipulates utilization category AC-6b. The operational currents or powers acceptable for the contactors are determined by our electrical tests; IEC publication 60947-4-1 gives the calculating formula for determining the operational current (Table 9).

#### Transformer switching

Account must be taken of the peaks due to magnetization phenomena when the current is made. For this application, IEC publication 60947-4-1 stipulates utilization category AC-6a. The operational currents or powers acceptable for the contactors are determined using the values obtained for AC-3 or AC-4 category tests and the calculating formula given in IEC 60947-4-1 (Table 9).

#### Lighting circuit switching

The current peaks occurring on energization of the circuit and the power factor depend on the type of lamps, the connection mode and whether or not there is compensation.

For this application, IEC publication 60947-4-1 stipulates two standard utilization categories:

AC-5a for discharge lamp switching.

AC-5b for incandescent lamp switching.

#### Slip-ring motor switching

The contactors used for short-circuiting rotor resistors can be used for rotor voltages up to 2 times the rated operational voltage.

The conditions of use of rotor contactors depend on the connection mode of the main poles. IEC 60947-4-1 stipulates AC-2 utilization category for startor contactor.

## Standards and utilization categories

### Utilization categories (cont.)

#### DC power circuit switching

Arc suppression is more difficult in direct current than in alternating current. Higher the time constant and voltage, heavier the breaking conditions: consequently several poles have to be connected in series.

#### AC high current circuit switching

Possibility of increasing performances by connecting poles in parallel.

#### Circuit switching during temporary and intermittent duty

In these cases higher operational currents are acceptable.

#### Influence of the length of the conductors used in the contactor control circuit

According to the operational voltages, the cross-sectional areas, the coil consumption and the control layout, difficulties due to line resistances and capacitances may appear during contactor closing and opening orders.

### Making and breaking conditions for utilization categories

Utilization category	Durability test conditions						Occasional operation					
	Making conditions			Breaking conditions			Making and breaking capacities - 50 operating cycles					
	I/le	U/Ur	Cos. $\phi$ or L/R (ms)	I/le	U/Ur	Cos. $\phi$ or L/R (ms)	Making conditions		Breaking conditions		Cos. $\phi$ or L/R (ms)	
						Ic/le	Ur/Ur	Cos. $\phi$ or L/R (ms)	Ic/le	Ur/Ur	Cos. $\phi$ or L/R (ms)	

#### Contactors for AC circuit switching

AC-1		1	1	0.95	1	1	0.95	1.5	1.05	0.8	1.5	1.05	0.8
AC-2		2.5	1	0.65	2.5	1	0.65	4	1.05	0.65	4	1.05	0.65
AC-3	le < 17 A	6	1	0.65	1	0.17	0.65	10	1.05	0.45	8	1.05	0.45
	17 < le < 100 A	6	1	0.35	1	0.17	0.35	10	1.05	0.45	8	1.05	0.45
	le > 100 A	6	1	0.35	1	0.17	0.35	10	1.05	0.35	8	1.05	0.35
AC-4	le < 17 A	6	1	0.65	6	1	0.65	12	1.05	0.45	10	1.05	0.45
	17 < le < 100 A	6	1	0.35	6	1	0.35	12	1.05	0.45	10	1.05	0.45
	le > 100 A	6	1	0.35	6	1	0.35	12	1.05	0.35	10	1.05	0.35

#### Contactors for DC circuit switching

DC-1		1	1	1	1	1	1	1.5	1.05	1	1.5	1.05	1
DC-3		2.5	1	2	2.5	1	2	4	1.05	2.5	4	1.05	2.5
DC-5		2.5	1	7.5	2.5	1	7.5	4	1.05	15	4	1.05	15

#### Contactor relays for AC circuit switching

AC-14	( $\leq 72$ VA)	-	-	-	-	-	-	6	1.1	0.7	6	1.1	0.7
AC-15	(> 72 VA)	10	1	0.7	1	1	0.4	10	1.1	0.3	10	1.1	0.3

#### Contactor relays for DC circuit switching

Utilization category	Standard operation						Occasional operation						
	Making conditions			Breaking conditions			Making and breaking capacities - 50 operating cycles						
	I/le	U/Ur	T0.95	I/le	U/Ur	T0.95	Making conditions		Breaking conditions		T0.95		
						Ic/le	Ur/Ur	T0.95	Ic/le	Ur/Ur	T0.95		
DC-13		1	1	6 P(1)	1	1	6 P(1)	1.1	1.1	6 P(1)	1.1	1.1	6 P(1)
DC-14		-	-	-	-	-	-	10	1.1	15 ms	10	1.1	15 ms

(1) The value "6 x P" is the result of an empirical relation which is estimated to represent most DC magnetic loads up to the highest limit of P = 50 W (6 x P = 300 ms). It is accepted that loads having drawn energy above 50 W are made up of weaker loads in parallel. As a consequence, the 300 ms value must form the highest limit whatever the value of the power drawn.

#### Key:

**U (I)** = applied voltage (current)

**Ur** = recovery voltage

**L/R** = test circuit time constant

**Ue (Ie)** = rated operational voltage (current)

**Ic** = making and breaking current expressed in DC or in AC like the r.m.s. value of the symmetrical components

**T0.95** = time required to reach 95 % of the current in steady-state conditions, expressed in milliseconds

## Degrees of protection

### General

In an installation, the degree of protection required for electrical equipment depends on the environmental characteristics. The degree of protection, ensured by the enclosure of equipment or by the cubicle containing the equipment is expressed by the IP code which gives the level of protection against access to hazardous parts, the ingress of foreign bodies and/or the ingress of water, in compliance with IEC 60529, IEC 60947-1.

Besides the IP symbol, the complete code has two figures followed (optionally) by two additional letters. A short description of the elements used in IP coding is given below.

IP... code	Figures or letters	Specifications for installation protection	Protection of persons
<b>First figure</b>		<b>Against ingress of foreign bodies</b>	<b>Against access to hazardous parts with:</b>
	0	No protection	No protection
	1	Diameter > 50 mm	Back of hand
	2	Diameter > 12.5 mm	Finger
	3	Diameter > 2.5 mm	Tool
	4	Diameter > 1 mm	Wire
	5	Limited protection against dust	Wire
	6	Total protection against dust	Wire
<b>Second figure</b>		<b>Against entrance of water having a harmful effect</b>	
	0	No protection	
	1	Vertical dripping	
	2	Dripping at a vertical angle of < 15°	
	3	Rain at a vertical angle of < 60°	
	4	Splashing	
	5	Low pressure water jet	
	6	Powerful water jets	
	7	Temporary immersion	
	8	Permanent immersion	
<b>Additional letter (optional) for use with:</b>		<b>Against ingress of foreign bodies</b>	<b>Against access to hazardous parts with:</b>
First figure 0	A	Stopped by a barrier with a 50 mm Ø sphere	Back of hand
First figure 0 or 1	B	Entrance of test finger limited to 80 mm	Finger
First figure 1 or 2	C	Wire with 2.5 mm Ø and length of 100 mm	Tool
First figure 2 or 3	D	Wire with 1 mm Ø and length of 100 mm	Wire
<b>Additional letter (optional)</b>		<b>Specific additional information</b>	
	H	High voltage apparatus	-
	M	Moving parts which are moving during water test	
	S	Moving parts which are stationary during water test	
	W	Specified atmospheric conditions	

Note: The type of enclosure or cubicle in which the equipment must be installed prevails with respect to the degree of protection.

## Index

Order code	Type	Page	Order code	Type	Page	Order code	Type	Page
1SAM101923R0002	MSMN (3)	25	1SAM250000R1009	MS116-6.3	13	1SBL281074R2601	AX32-30-01-26	30
1SAM101923R0012	MSMNO (4)	25	1SAM250000R1010	MS116-10	13	1SBL281074R2610	AX32-30-10-26	30
1SAM201901R1001	HKF1-11	18	1SAM250000R1011	MS116-16	13	1SBL281074R7501	AX32-30-01-75	30
1SAM201901R1002	HKF1-20	18	1SAM250000R1012	MS116-12	13	1SBL281074R7510	AX32-30-10-75	30
1SAM201901R1003	HKF1-10	18	1SAM250000R1013	MS116-20	13	1SBL281074R8101	AX32-30-01-81	30
1SAM201901R1004	HKF1-01	18	1SAM250000R1014	MS116-25	13	1SBL281074R8110	AX32-30-10-81	30
1SAM201902R1001	HK1-11	18	1SAM250000R1015	MS116-32	13	1SBL281074R8501	AX32-30-01-85	30
1SAM201902R1002	HK1-20	18	1SAM250005R1001	MS116-0.16-HKF1-11	13	1SBL281074R8510	AX32-30-10-85	30
1SAM201902R1003	HK1-02	18	1SAM250005R1002	MS116-0.4-HKF1-11	13	1SBL321074R2601	AX40-30-01-26	30
1SAM201902R1004	HK1-20L	18	1SAM250005R1003	MS116-0.4-HKF1-11	13	1SBL321074R2610	AX40-30-10-26	30
1SAM201903R1001	SK1-11	18	1SAM250005R1004	MS116-0.63-HKF1-11	13	1SBL321074R7501	AX40-30-01-75	30
1SAM201903R1002	SK1-20	18	1SAM250005R1005	MS116-1.0-HKF1-11	13	1SBL321074R7510	AX40-30-10-75	30
1SAM201903R1003	SK1-02	18	1SAM250005R1006	MS116-1.6-HKF1-11	13	1SBL321074R8101	AX40-30-01-81	30
1SAM201904R1001	UA1-24	19	1SAM250005R1007	MS116-2.5-HKF1-11	13	1SBL321074R8110	AX40-30-10-81	30
1SAM201904R1002	UA1-48	19	1SAM250005R1008	MS116-4.0-HKF1-11	13	1SBL321074R8501	AX40-30-01-85	30
1SAM201904R1003	UA1-60	19	1SAM250005R1009	MS116-6.3-HKF1-11	13	1SBL321074R8510	AX40-30-10-85	30
1SAM201904R1004	UA1-110	19	1SAM250005R1010	MS116-10.0-HKF1-11	13	1SBL351074R2600	AX50-30-00-26	31
1SAM201904R1005	UA1-230	19	1SAM250005R1011	MS116-16.0-HKF1-11	13	1SBL351074R2611	AX50-30-11-26	32
1SAM201904R1006	UA1-400	19	1SAM250005R1012	MS116-12.0-HKF1-11	13	1SBL351074R7500	AX50-30-00-75	31
1SAM201904R1007	UA1-415	19	1SAM250005R1013	MS116-20-HKF1-11	13	1SBL351074R7511	AX50-30-11-75	32
1SAM201904R1008	UA1-208	19	1SAM250005R1014	MS116-25-HKF1-11	13	1SBL351074R8100	AX50-30-00-81	31
1SAM201904R1009	UA1-575	19	1SAM250005R1015	MS116-32-HKF1-11	13	1SBL351074R8111	AX50-30-11-81	32
1SAM201904R1010	UA1-20	19	1SAZ201108R0001	DB25/25A	93	1SBL351074R8500	AX50-30-00-85	31
1SAM201906R1102	PS1-2-0-65	22	1SAZ201108R0002	DB25/32A	93	1SBL351074R8511	AX50-30-11-85	32
1SAM201906R1103	PS1-3-0-65	22	1SAZ201307R0002	DX25	93	1SBL371074R2600	AX65-30-00-26	31
1SAM201906R1104	PS1-4-0-65	22	1SAZ211201R2005	TA25DU-0.16M	89	1SBL371074R2611	AX65-30-11-26	32
1SAM201906R1105	PS1-5-0-65	22	1SAZ211201R2009	TA25DU-0.25M	89	1SBL371074R7500	AX65-30-00-75	31
1SAM201906R1112	PS1-2-1-65	22	1SAZ211201R2013	TA25DU-0.4M	89	1SBL371074R7511	AX65-30-11-75	32
1SAM201906R1113	PS1-3-1-65	22	1SAZ211201R2017	TA25DU-0.63M	89	1SBL371074R8100	AX65-30-00-81	31
1SAM201906R1114	PS1-4-1-65	22	1SAZ211201R2021	TA25DU-1.0M	89	1SBL371074R8111	AX65-30-11-81	32
1SAM201906R1115	PS1-5-1-65	22	1SAZ211201R2023	TA25DU-1.4M	89	1SBL371074R8500	AX65-30-00-85	31
1SAM201906R1122	PS1-2-2-65	22	1SAZ211201R2025	TA25DU-1.8M	89	1SBL371074R8511	AX65-30-11-85	32
1SAM201906R1123	PS1-3-2-65	22	1SAZ211201R2028	TA25DU-2.4M	89	1SBL411074R2600	AX80-30-00-26	31
1SAM201906R1124	PS1-4-2-65	22	1SAZ211201R2031	TA25DU-3.1M	89	1SBL411074R2611	AX80-30-11-26	32
1SAM201906R1125	PS1-5-2-65	22	1SAZ211201R2033	TA25DU-4.0M	89	1SBL411074R7500	AX80-30-00-75	31
1SAM201907R1101	S1-M1-25	22	1SAZ211201R2035	TA25DU-5.0M	89	1SBL411074R7511	AX80-30-11-75	32
1SAM201907R1102	S1-M2-25	22	1SAZ211201R2038	TA25DU-6.5M	89	1SBL411074R8100	AX80-30-00-81	31
1SAM201907R1103	S1-M3-25	22	1SAZ211201R2040	TA25DU-8.5M	89	1SBL411074R8111	AX80-30-11-81	32
1SAM201908R1001	BS1-3	22	1SAZ211201R2043	TA25DU-11M	89	1SBL411074R8500	AX80-30-00-85	31
1SAM201909R1001	FS116	22	1SAZ211201R2045	TA25DU-14M	89	1SBL411074R8511	AX80-30-11-85	32
1SAM201909R1021	MSAH1	25	1SAZ211201R2047	TA25DU-19M	89	1SBL901074R2601	AX09-30-01-26	28
1SAM201910R1001	AA1-24	19	1SAZ211201R2051	TA25DU-25M	89	1SBL901074R2610	AX09-30-10-26	28
1SAM201910R1002	AA1-110	19	1SAZ211201R2053	TA25DU-32M	89	1SBL901074R7501	AX09-30-01-75	28
1SAM201910R1003	AA1-230	19	1SAZ301110R0001	DB80	93, 94	1SBL901074R7510	AX09-30-10-75	28
1SAM201910R1004	AA1-400	19	1SAZ311201R2001	TA42DU-25M	89	1SBL901074R8101	AX09-30-01-81	28
1SAM201911R1010	IB132-G	24	1SAZ311201R2002	TA42DU-32M	89	1SBL901074R8110	AX09-30-10-81	28
1SAM201911R1011	IB132-Y	24	1SAZ311201R2003	TA42DU-42M	89	1SBL901074R8501	AX09-30-01-85	28
1SAM201912R1010	DMS132-G	24	1SAZ321201R2001	TA75DU-25M	89	1SBL901074R8510	AX09-30-10-85	28
1SAM201912R1011	DMS132-Y	24	1SAZ321201R2002	TA75DU-32M	89	1SBL911074R2601	AX12-30-01-26	28
1SAM201913R1103	S1-M3-35	22	1SAZ321201R2003	TA75DU-42M	89	1SBL911074R2610	AX12-30-10-26	28
1SAM201914R1001	PB1-1-32	22	1SAZ321201R2004	TA75DU-52M	89	1SBL911074R7501	AX12-30-01-75	28
1SAM201914R1002	S1-PB1-25	22	1SAZ321201R2005	TA75DU-63M	89	1SBL911074R7510	AX12-30-10-75	28
1SAM201916R1103	PS1-3-0-100	22	1SAZ321201R2006	TA75DU-80M	89	1SBL911074R8101	AX12-30-01-81	28
1SAM201916R1104	PS1-4-0-100	22	1SAZ331201R2003	TA80DU-42M	94	1SBL911074R8110	AX12-30-10-81	28
1SAM201916R1105	PS1-5-0-100	22	1SAZ331201R2004	TA80DU-52M	94	1SBL911074R8501	AX12-30-01-85	28
1SAM201916R1113	PS1-3-1-100	22	1SAZ331201R2005	TA80DU-63M	94	1SBL911074R8510	AX12-30-10-85	28
1SAM201916R1114	PS1-4-1-100	22	1SAZ331201R2006	TA80DU-80M	94	1SBL921074R2601	AX18-30-01-26	29
1SAM201916R1115	PS1-5-1-100	22	1SAZ401110R0001	DB200	94	1SBL921074R2610	AX18-30-10-26	29
1SAM201916R1123	PS1-3-2-100	22	1SAZ411201R2001	TA110DU-90M	94	1SBL921074R7501	AX18-30-01-75	29
1SAM201920R1000	MSH-AR	25	1SAZ411201R2002	TA110DU-110M	94	1SBL921074R7510	AX18-30-10-75	29
1SAM201920R1001	MSHD-LB (1)	25	1SBH901074R2622	NX22E-26	58	1SBL921074R8101	AX18-30-01-81	29
1SAM201920R1002	MSHD-LY (1)	25	1SBH901074R2631	NX31E-26	58	1SBL921074R8110	AX18-30-10-81	29
1SAM201920R1011	MSHD-LTB (2)	25	1SBH901074R2640	NX40E-26	58	1SBL921074R8501	AX18-30-01-85	29
1SAM201920R1012	MSHD-LTY( 2)	25	1SBH901074R7522	NX22E-75	58	1SBL921074R8510	AX18-30-10-85	29
1SAM250000R1001	MS116-0.16	13	1SBH901074R7531	NX31E-75	58	1SBL931074R2601	AX25-30-01-26	29
1SAM250000R1002	MS116-0.25	13	1SBH901074R7540	NX40E-75	58	1SBL931074R2610	AX25-30-10-26	29
1SAM250000R1003	MS116-0.4	13	1SBH901074R8122	NX22E-81	58	1SBL931074R7501	AX25-30-01-75	29
1SAM250000R1004	MS116-0.63	13	1SBH901074R8131	NX31E-81	58	1SBL931074R7510	AX25-30-10-75	29
1SAM250000R1005	MS116-1.0	13	1SBH901074R8140	NX40E-81	58	1SBL931074R8101	AX25-30-01-81	29
1SAM250000R1006	MS116-1.6	13	1SBH901074R8522	NX22E-85	58	1SBL931074R8110	AX25-30-10-81	29
1SAM250000R1007	MS116-2.5	13	1SBH901074R8531	NX31E-85	58	1SBL931074R8501	AX25-30-01-85	29
1SAM250000R1008	MS116-4.0	13	1SBH901074R8540	NX40E-85	58	1SBL931074R8510	AX25-30-10-85	29

## Index

Order code	Type	Page
1SBN010015R1001	CE5-01D0.1	66
1SBN010015R1010	CE5-10D0.1	66
1SBN010016R1001	CE5-01W0.1	66
1SBN010016R1010	CE5-10W0.1	66
1SBN010017R1001	CE5-01D2	66
1SBN010017R1010	CE5-10D2	66
1SBN010018R1001	CE5-01W2	66
1SBN010018R1010	CE5-10W2	66
1SBN019010R1001	CA5X-01	35, 64
1SBN019010R1010	CA5X-10	35, 64
1SBN019020R1011	CAL5X-11	35, 64
1SBN019040R1022	CA5X-22E	35, 64
1SBN019040R1122	CA5X-22M	35, 64
1SBN020312R1000	TEF5-ON	36, 69
1SBN020314R1000	TEF5-OFF	36, 69
1SBN030100R1000	VM5-1	35, 72
1SBN030110R1000	VE5-1	35, 72
1SBN030210R1000	VE5-2	35, 72
1SBN050010R1000	RV5/50	36, 78
1SBN050010R1001	RV5/133	36, 78
1SBN050010R1002	RV5/250	36, 78
1SBN050010R1003	RV5/440	36, 78
1SBN050100R1000	RC5-1/50	36, 78
1SBN050100R1001	RC5-1/133	36, 78
1SBN050100R1002	RC5-1/250	36, 78
1SBN050100R1003	RC5-1/440	36, 78
1SBN050200R1000	RC5-2/50	36, 78
1SBN050200R1001	RC5-2/133	36, 78
1SBN050200R1002	RC5-2/250	36, 78
1SBN050200R1003	RC5-2/440	36, 78
1SBN060300R1000	RA5-1	74
1SBN073508R1000	LD75	80
1SBN073552R1002	LK75-F	81
1SBN081406R1000	BEA16/116	36, 83
1SBN081411R1000	BER16V	83
1SBN082411R1000	BER40V	83
1SBN083501R1000	BEM75-30	83
1SBN083504R1000	BES75-30	84
1SBN110000R1000	BA5-50	81
1SBN060300T1000	RA5-1	74
1SBN089306T1000	BEA25/116	36, 83
1SBN089306T1001	BEA25/132	36, 83
1SCA101647R1001	OXS6X85	25
1SCA101655R1001	OXS6X130	25
1SCA101659R1001	OXS6X180	25
1SCA108043R1001	OXS6X105	25
1SFA616162R1014	KPR-101L	93, 94
1SFL431074R2611	AX95-30-11-26	33
1SFL431074R7511	AX95-30-11-75	33
1SFL431074R8111	AX95-30-11-81	33
1SFL431074R8511	AX95-30-11-85	33
1SFL981074R2611	AX115-30-11-26	33
1SFL981074R7511	AX115-30-11-75	33
1SFL981074R8111	AX115-30-11-81	33
1SFL981074R8511	AX115-30-11-85	33
1SFL991074R2611	AX150-30-11-26	33
1SFL991074R7511	AX150-30-11-75	33
1SFL991074R8111	AX150-30-11-81	33
1SFL991074R8511	AX150-30-11-85	33
1SFN019820R1011	CAL18X-11	35, 64
1SFN034701R1000	VM300V	72
1SFN074308R1000	LD110	80
1SFN084301R1000	BEM110-30	83
1SFN084304R1000	BES110	84
1SFN084503R1000	BED110	84
1SVR730100R0300	CT-ERS.21S	52
1SVR730210R3300	CT-SDS.22S	52
1SVR730211R2300	CT-SDS.23S	52
FPEP407000R0001	LP16	82
FPEP407002R0001	LY16	82
FPTN372726R1001	WB75-A	36, 76
FPTN372726R1002	WB75-A	76

Order code	Type	Page
FPTN372726R1003	WB75-A	76
FPTN372726R1004	WB75-A	76
FPTN372726R1005	WB75-A	76
FPTN372726R1006	WB75-A	36, 76
FPTN372726R1007	WB75-A	76
FPTN372726R1008	WB75-A	76
GJF1101903R0001	SA1	22
GJF1101903R0002	SA2	22
GJF1101903R0003	SA3	22

Order code	Type	Page
------------	------	------

# Index

Type	Order code	Page
AA1-110	1SAM201910R1002	19
AA1-230	1SAM201910R1003	19
AA1-24	1SAM201910R1001	19
AA1-400	1SAM201910R1004	19
AX09-30-01-26	1SBL901074R2601	28
AX09-30-01-75	1SBL901074R7501	28
AX09-30-01-81	1SBL901074R8101	28
AX09-30-01-85	1SBL901074R8501	28
AX09-30-10-26	1SBL901074R2610	28
AX09-30-10-75	1SBL901074R7510	28
AX09-30-10-81	1SBL901074R8110	28
AX09-30-10-85	1SBL901074R8510	28
AX115-30-11-26	1SFL981074R2611	33
AX115-30-11-75	1SFL981074R7511	33
AX115-30-11-81	1SFL981074R8111	33
AX115-30-11-85	1SFL981074R8511	33
AX12-30-01-26	1SBL911074R2601	28
AX12-30-01-75	1SBL911074R7501	28
AX12-30-01-81	1SBL911074R8101	28
AX12-30-01-85	1SBL911074R8501	28
AX12-30-10-26	1SBL911074R2610	28
AX12-30-10-75	1SBL911074R7510	28
AX12-30-10-81	1SBL911074R8110	28
AX12-30-10-85	1SBL911074R8510	28
AX150-30-11-26	1SFL991074R2611	33
AX150-30-11-75	1SFL991074R7511	33
AX150-30-11-81	1SFL991074R8111	33
AX150-30-11-85	1SFL991074R8511	33
AX18-30-01-26	1SBL921074R2601	29
AX18-30-01-75	1SBL921074R7501	29
AX18-30-01-81	1SBL921074R8101	29
AX18-30-01-85	1SBL921074R8501	29
AX18-30-10-26	1SBL921074R2610	29
AX18-30-10-75	1SBL921074R7510	29
AX18-30-10-81	1SBL921074R8110	29
AX18-30-10-85	1SBL921074R8510	29
AX25-30-01-26	1SBL931074R2601	29
AX25-30-01-75	1SBL931074R7501	29
AX25-30-01-81	1SBL931074R8101	29
AX25-30-01-85	1SBL931074R8501	29
AX25-30-10-26	1SBL931074R2610	29
AX25-30-10-75	1SBL931074R7510	29
AX25-30-10-81	1SBL931074R8110	29
AX25-30-10-85	1SBL931074R8510	29
AX32-30-01-26	1SBL281074R2601	30
AX32-30-01-75	1SBL281074R7501	30
AX32-30-01-81	1SBL281074R8101	30
AX32-30-01-85	1SBL281074R8501	30
AX32-30-10-26	1SBL281074R2610	30
AX32-30-10-75	1SBL281074R7510	30
AX32-30-10-81	1SBL281074R8110	30
AX32-30-10-85	1SBL281074R8510	30
AX40-30-01-26	1SBL321074R2601	30
AX40-30-01-75	1SBL321074R7501	30
AX40-30-01-81	1SBL321074R8101	30
AX40-30-01-85	1SBL321074R8501	30
AX40-30-10-26	1SBL321074R2610	30
AX40-30-10-75	1SBL321074R7510	30
AX40-30-10-81	1SBL321074R8110	30
AX40-30-10-85	1SBL321074R8510	30
AX50-30-00-26	1SBL351074R2600	31
AX50-30-00-75	1SBL351074R7500	31
AX50-30-00-81	1SBL351074R8100	31
AX50-30-00-85	1SBL351074R8500	31
AX50-30-11-26	1SBL351074R2611	32
AX50-30-11-75	1SBL351074R7511	32
AX50-30-11-81	1SBL351074R8111	32
AX50-30-11-85	1SBL351074R8511	32
AX65-30-00-26	1SBL371074R2600	31
AX65-30-00-75	1SBL371074R7500	31
AX65-30-00-81	1SBL371074R8100	31
AX65-30-00-85	1SBL371074R8500	31

Type	Order code	Page
AX65-30-11-26	1SBL371074R2611	32
AX65-30-11-75	1SBL371074R7511	32
AX65-30-11-81	1SBL371074R8111	32
AX65-30-11-85	1SBL371074R8511	32
AX80-30-00-26	1SBL411074R2600	31
AX80-30-00-75	1SBL411074R7500	31
AX80-30-00-81	1SBL411074R8100	31
AX80-30-00-85	1SBL411074R8500	31
AX80-30-11-26	1SBL411074R2611	32
AX80-30-11-75	1SBL411074R7511	32
AX80-30-11-81	1SBL411074R8111	32
AX80-30-11-85	1SBL411074R8511	32
AX95-30-11-26	1SFL431074R2611	33
AX95-30-11-75	1SFL431074R7511	33
AX95-30-11-81	1SFL431074R8111	33
AX95-30-11-85	1SFL431074R8511	33
BA5-50	1SBN110000R1000	81
BEA16/116	1SBN081406R1000	36, 83
BEA25/116	1SBN089306T1000	36, 83
BEA25/132	1SBN089306T1001	36, 83
BED110	1SFN084503R1000	84
BEM110-30	1SFN084301R1000	83
BEM75-30	1SBN083501R1000	83
BER16V	1SBN081411R1000	83
BER40V	1SBN082411R1000	83
BES110	1SFN084304R1000	84
BES75-30	1SBN083504R1000	84
BS1-3	1SAM201908R1001	22
CA5X-01	1SBN019010R1001	35, 64
CA5X-10	1SBN019010R1010	35, 64
CA5X-22E	1SBN019040R1022	35, 64
CA5X-22M	1SBN019040R1122	35, 64
CAL18X-11	1SFN019820R1011	35, 64
CAL5X-11	1SBN019020R1011	35, 64
CE5-01D0.1	1SBN010015R1001	66
CE5-01D2	1SBN010017R1001	66
CE5-01W0.1	1SBN010016R1001	66
CE5-01W2	1SBN010018R1001	66
CE5-10D0.1	1SBN010015R1010	66
CE5-10D2	1SBN010017R1010	66
CE5-10W0.1	1SBN010016R1010	66
CE5-10W2	1SBN010018R1010	66
CT-ERS.21S	1SVR730100R0300	52
CT-SDS.22S	1SVR730210R3300	52
CT-SDS.23S	1SVR730211R2300	52
DB200	1SAZ401110R0001	94
DB25/25A	1SAZ201108R0001	93
DB25/32A	1SAZ201108R0002	93
DB80	1SAZ301110R0001	93, 94
DMS132-G	1SAM201912R1010	24
DMS132-Y	1SAM201912R1011	24
DX25	1SAZ201307R0002	93
FS116	1SAM201909R1001	22
HK1-02	1SAM201902R1003	18
HK1-11	1SAM201902R1001	18
HK1-20	1SAM201902R1002	18
HK1-20L	1SAM201902R1004	18
HKF1-01	1SAM201901R1004	18
HKF1-10	1SAM201901R1003	18
HKF1-11	1SAM201901R1001	18
HKF1-20	1SAM201901R1002	18
IB132-G	1SAM201911R1010	24
IB132-Y	1SAM201911R1011	24
KPR-101L	1SFA616162R1014	93, 94
LD110	1SFN074308R1000	80
LD75	1SBN073508R1000	80
LK75-F	1SBN073522R1002	81
LP16	FPEP407000R0001	82
LY16	FPEP407002R0001	82
MS116-0.16	1SAM250000R1001	13
MS116-0.16-HKF1-11	1SAM250005R1001	13
MS116-0.25	1SAM250000R1002	13

Type	Order code	Page
MS116-0.25-HKF1-11	1SAM250005R1002	13
MS116-0.4	1SAM250000R1003	13
MS116-0.4-HKF1-11	1SAM250005R1003	13
MS116-0.63	1SAM250000R1004	13
MS116-0.63-HKF1-11	1SAM250005R1004	13
MS116-1.0	1SAM250000R1005	13
MS116-1.0-HKF1-11	1SAM250005R1005	13
MS116-1.6	1SAM250000R1006	13
MS116-1.6-HKF1-11	1SAM250005R1006	13
MS116-10	1SAM250000R1010	13
MS116-10.0-HKF1-11	1SAM250005R1010	13
MS116-12	1SAM250000R1012	13
MS116-12.0-HKF1-11	1SAM250005R1012	13
MS116-16	1SAM250000R1011	13
MS116-16.0-HKF1-11	1SAM250005R1011	13
MS116-2.5	1SAM250000R1007	13
MS116-2.5-HKF1-11	1SAM250005R1007	13
MS116-20	1SAM250000R1013	13
MS116-20-HKF1-11	1SAM250005R1013	13
MS116-25	1SAM250000R1014	13
MS116-25-HKF1-11	1SAM250005R1014	13
MS116-32	1SAM250000R1015	13
MS116-32-HKF1-11	1SAM250005R1015	13
MS116-4.0	1SAM250000R1008	13
MS116-4.0-HKF1-11	1SAM250005R1008	13
MS116-6.3	1SAM250000R1009	13
MS116-6.3-HKF1-11	1SAM250005R1009	13
MSAH1	1SAM201909R1021	25
MSH-AR	1SAM201920R1000	25
MSHD-LB (1)	1SAM201920R1001	25
MSHD-LTB (2)	1SAM201920R1011	25
MSHD-LTY (2)	1SAM201920R1012	25
MSHD-LY (1)	1SAM201920R1002	25
MSMN (3)	1SAM101923R0002	25
MSMNO (4)	1SAM101923R0012	25
NX22E-26	1SBH901074R2622	58
NX22E-75	1SBH901074R7522	58
NX22E-81	1SBH901074R8122	58
NX22E-85	1SBH901074R8522	58
NX31E-26	1SBH901074R2631	58
NX31E-75	1SBH901074R7531	58
NX31E-81	1SBH901074R8131	58
NX31E-85	1SBH901074R8531	58
NX40E-26	1SBH901074R2640	58
NX40E-75	1SBH901074R7540	58
NX40E-81	1SBH901074R8140	58
NX40E-85	1SBH901074R8540	58
OXS6X105	1SCA108043R1001	25
OXS6X130	1SCA101655R1001	25
OXS6X180	1SCA101659R1001	25
OXS6X85	1SCA101647R1001	25
PB1-1-32	1SAM201914R1001	22
PS1-2-0-65	1SAM201906R1102	22
PS1-2-1-65	1SAM201906R1112	22
PS1-2-2-65	1SAM201906R1122	22
PS1-3-0-100	1SAM201916R1103	22
PS1-3-0-65	1SAM201906R1103	22
PS1-3-1-100	1SAM201916R1113	22
PS1-3-1-65	1SAM201906R1113	22
PS1-3-2-100	1SAM201916R1123	22
PS1-3-2-65	1SAM201906R1123	22
PS1-4-0-100	1SAM201916R1104	22
PS1-4-0-65	1SAM201906R1104	22
PS1-4-1-100	1SAM201916R1114	22
PS1-4-1-65	1SAM201906R1114	22
PS1-4-2-65	1SAM201906R1124	22
PS1-5-0-100	1SAM201916R1105	22
PS1-5-0-65	1SAM201906R1105	22
PS1-5-1-100	1SAM201916R1115	22
PS1-5-1-65	1SAM201906R1115	22
PS1-5-2-65	1SAM201906R1125	22
RA5-1	1SBN060300R1000	74



## Index

Type	Order code	Page	Type	Order code	Page	Type	Order code	Page
RA5-1	1SBN060300T1000	74	VM5-1	1SBN030100R1000	35, 72			
RC5-1/133	1SBN050100R1001	36, 78	WB75-A	FPTN372726R1001	36, 76			
RC5-1/250	1SBN050100R1002	36, 78	WB75-A	FPTN372726R1002	76			
RC5-1/440	1SBN050100R1003	36, 78	WB75-A	FPTN372726R1003	76			
RC5-1/50	1SBN050100R1000	36, 78	WB75-A	FPTN372726R1004	76			
RC5-2/133	1SBN050200R1001	36, 78	WB75-A	FPTN372726R1005	76			
RC5-2/250	1SBN050200R1002	36, 78	WB75-A	FPTN372726R1006	36, 76			
RC5-2/440	1SBN050200R1003	36, 78	WB75-A	FPTN372726R1007	76			
RC5-2/50	1SBN050200R1000	36, 78	WB75-A	FPTN372726R1008	76			
RV5/133	1SBN050010R1001	36, 78						
RV5/250	1SBN050010R1002	36, 78						
RV5/440	1SBN050010R1003	36, 78						
RV5/50	1SBN050010R1000	36, 78						
S1-M1-25	1SAM201907R1101	22						
S1-M2-25	1SAM201907R1102	22						
S1-M3-25	1SAM201907R1103	22						
S1-M3-35	1SAM201913R1103	22						
S1-PB1-25	1SAM201914R1002	22						
SA1	GJF1101903R0001	22						
SA2	GJF1101903R0002	22						
SA3	GJF1101903R0003	22						
SK1-02	1SAM201903R1003	18						
SK1-11	1SAM201903R1001	18						
SK1-20	1SAM201903R1002	18						
TA110DU-110M	1SAZ411201R2002	94						
TA110DU-90M	1SAZ411201R2001	94						
TA25DU-0.16M	1SAZ211201R2005	89						
TA25DU-0.25M	1SAZ211201R2009	89						
TA25DU-0.4M	1SAZ211201R2013	89						
TA25DU-0.63M	1SAZ211201R2017	89						
TA25DU-1.0M	1SAZ211201R2021	89						
TA25DU-1.4M	1SAZ211201R2023	89						
TA25DU-1.8M	1SAZ211201R2025	89						
TA25DU-11M	1SAZ211201R2043	89						
TA25DU-14M	1SAZ211201R2045	89						
TA25DU-19M	1SAZ211201R2047	89						
TA25DU-2.4M	1SAZ211201R2028	89						
TA25DU-25M	1SAZ211201R2051	89						
TA25DU-3.1M	1SAZ211201R2031	89						
TA25DU-32M	1SAZ211201R2053	89						
TA25DU-4.0M	1SAZ211201R2033	89						
TA25DU-5.0M	1SAZ211201R2035	89						
TA25DU-6.5M	1SAZ211201R2038	89						
TA25DU-8.5M	1SAZ211201R2040	89						
TA42DU-25M	1SAZ311201R2001	89						
TA42DU-32M	1SAZ311201R2002	89						
TA42DU-42M	1SAZ311201R2003	89						
TA75DU-25M	1SAZ321201R2001	89						
TA75DU-32M	1SAZ321201R2002	89						
TA75DU-42M	1SAZ321201R2003	89						
TA75DU-52M	1SAZ321201R2004	89						
TA75DU-63M	1SAZ321201R2005	89						
TA75DU-80M	1SAZ321201R2006	89						
TA80DU-42M	1SAZ331201R2003	94						
TA80DU-52M	1SAZ331201R2004	94						
TA80DU-63M	1SAZ331201R2005	94						
TA80DU-80M	1SAZ331201R2006	94						
TEF5-OFF	1SBN020314R1000	36, 69						
TEF5-ON	1SBN020312R1000	36, 69						
UA1-110	1SAM201904R1004	19						
UA1-20	1SAM201904R1010	19						
UA1-208	1SAM201904R1008	19						
UA1-230	1SAM201904R1005	19						
UA1-24	1SAM201904R1001	19						
UA1-400	1SAM201904R1006	19						
UA1-415	1SAM201904R1007	19						
UA1-48	1SAM201904R1002	19						
UA1-575	1SAM201904R1009	19						
UA1-60	1SAM201904R1003	19						
VE5-1	1SBN030110R1000	35, 72						
VE5-2	1SBN030210R1000	35, 72						
VM300V	1SFN034701R1000	72						







---

**ABB France**

**Electrification Products Division  
Low Voltage Products and Systems**

3, rue Jean Perrin  
F-69687 Chassieu cedex / France

---

**ABB STOTZ-KONTAKT GmbH**

**Electrification Business  
Low Voltage Products and Systems**

Eppelheimer Straße 82  
D-69123 Heidelberg / Germany

**You can find the address of your local sales organization  
on the ABB home page**



<http://new.abb.com/low-voltage>



<http://new.abb.com/low-voltage/products/connection-devices>

We reserve the right to make technical changes or modify the contents of this document without prior notice. ABB does not accept any responsibility whatsoever for potential errors or possible lack of information in this document.

We reserve all rights in this document and in the subject matter and illustrations contained therein. Any reproduction, disclosure to third parties or utilization of its contents – in whole or in parts – is forbidden without prior written consent of ABB.

Copyright© 2023 ABB - All rights reserved