

Multi Vision™
Digital Transmitter

2020TG for Gauge Pressure
and Level
2020TA for Absolute Pressure

Instructions

42/15-753-7 EN



Contents

	page
1 Safety	2
General safety precautions and health protection	2
Correct usage	2
2 Transport and Storage	2
3 General Description	3
Principle of operation and construction	3
Documentation	3
4 Mounting	4
General	4
Transmitter	4
Measurement piping	4
5 Electrical Connection	4
Electrical connection in the cable connection compartment .	4
Electrical connection with plug	4
Mounting of the socket connector	4
Protective conductor / grounding	5
Set-up of the signal circuit / communication circuit	5
of transmitters with 4...20 mA-output signal	
Notes for connecting the cable	5
Notes on PROFIBUS-PA transmitters	6
Notes on explosion protection	6
6 Commissioning	7
Notes of transmitters with 4...20mA-output signal	7
Write protection	7
Oblique sensor / zero correction	7
Rotate housing with regard to the sensor	7
Assembly / disassembly of push button unit	7
Mount LCD-indicator	7
Secure enclosure cover for EEx d	8
Ventilation aperture for 2020TG with ranges \leq 30bar	8
7 Operation	8
Operation with "local keys" without LCD-indicator	8
Operation with "local keys" with LCD-indicator	9
Measured value display	10
Program control	11
Operation with PC / Laptop or Hand-held-terminal	12
8 Maintenance	13
9 Repairs	13
Return	13
10 Technical Data	13
11 Dimensional Diagrams	16
EC Declaration of Conformity	19
EC-Type-Examination Certificate (II1/2G EEx ia IIC T6) .	20

1 Safety

General safety precautions and health protection

To ensure safe operation of the 2020TA / 2020TG Transmitters, the following instructions have to be observed:

 **Please read these instructions / operating manual carefully prior to assembly and commissioning!**

For reasons of clarity the instructions do not contain all details on all types of product and do therefore not take into account every conceivable case of assembly, operation or maintenance.

If you want further information or if special problems arise which are not treated in detail in the instructions, please ask the manufacturer for the necessary information.

Moreover we would like to point out that the content of these in-

structions is neither part of nor provided for changing a previous or existing agreement, promise or legal relationship. All obligations of ABB Automation Products GmbH result from the respective sales contract which also comprises the complete and solely valid warranty clauses. Such contractual warranty clauses will neither be limited nor extended by the content of these instructions.

 **Observe warning signs at packaging etc.!**

 **For assembly, electrical connection, commissioning and maintenance of the transmitter, only qualified and authorized specialists are to be employed.**

Qualified specialists are persons who are experienced in the assembly, electrical connection, commissioning and operation of the transmitter or similar devices holding the necessary qualifications for their job, e.g.:

- Training or instruction and / or authorization to operate and maintain devices / systems according to the safety engineering standard for electric circuits, high pressures and aggressive media.

- Training or instruction according to the safety engineering standard regarding maintenance and use of adequate safety systems.

 For the sake of your own safety we draw your attention to the fact that for the electrical connection, only sufficiently isolated tools acc. to DIN EN 60 900 may be used.

- Furthermore the pertinent safety regulations concerning the construction and operation of electrical installations, e.g. the rule regarding technical working material §3 (safety rule for instruments), have to be observed.

- The pertinent standards, e.g. DIN 31 000 / VDE 1000.

- The regulations and recommendations relating to explosion protection if explosion-proof transmitters are to be installed.

- The device can be operated with high pressure and aggressive media.

 Serious injury and / or considerable material damage can therefore be caused when this device is handled incorrectly.

- The regulations, standards, recommendations and rules mentioned in these instructions are valid in Germany. When using the transmitter in other countries, the pertinent national rules have to be observed.

Correct usage

The 2020TA Transmitter measures absolute pressure and the 2020TG Transmitter gauge pressure or level of gases, vapors and liquids. The measuring ranges are graduated from 60 mbar to 600 bar (30 bar for absolute pressure). The permissible overload is 10 bar for measuring ranges up to 400 mbar, 2 x upper range value for measuring ranges up to 100 bar and 900 bar for a measuring range of 600 bar.

2 Transport and Storage

After unpacking the transmitter, check the device for transport damage. Check the packing material for accessories.

During intermediate storage / transport, store and transport the transmitter in the original packaging only. See section 10 "Technical Data" for permissible ambient conditions regarding storage and transport. The storage time is indefinite, however, the warranty conditions stipulated in the order confirmation of the supplier are valid.

3 General Description

The digital 2020TA / 2020TG Transmitters are communicating field devices with microprocessor-controlled electronic in multi-sensor technology.

For bi-directional communication, an FSK signal according to the HART® protocol or Bailey FSK protocol is overlaid to transmitters with 4 ... 20 mA output signal whereas, in case of fully digital transmitters, communication is effected via the fieldbus protocols PROFIBUS-PA or FOUNDATION Fieldbus, depending on the model.

The communication software SMART VISION allows PC-based configuration, scanning and testing of transmitters according to the respective protocol. Communication is also possible by means of a handheld terminal provided that the transmitters are working according to the HART® or Bailey FSK protocol.

For "local" operation, a control unit is optionally available which can also be retrofitted.

The control unit consists of two keys for the adjustment of zero and span and a write protect key. In conjunction with an installed LCD indicator, a complete external configuration and parameter setting of the transmitter is possible via the "local control unit", irrespective of the selected communication protocol.

As standard, the amplifier housing has a coat of varnish resistant to aggressive atmosphere; the process connection is made of stainless steel or Hastelloy C. The housing cover and the push button unit can be sealed.

The relevant transmitter data, such as transmitter type, communication, wetted parts material (O-ring, separating diaphragm or measuring diaphragm), measuring range, min. span, operating voltage, output signal, adjusted span and serial number (F.-No.) are to be found on the type plate. **In case of inquiries, please always indicate this number which is valid worldwide!**

For explosion-proof transmitters, the explosion protection type is described on a separate plate.

Another separate plate in front of the "local" control unit shows the functions of the three control elements by means of readily comprehensible symbols.

Additionally, a tie-on plate indicating the tag number may be attached (optional).

Principle of operation and construction

The transmitter has a modular design and consists of the pressure sensor module with an integrated electronic matching unit and an amplifier with control unit. Depending on measuring range and measured variable, either a ceramic pressure sensor or a silicon pressure sensor is used. In case of the ceramic pressure sensor, the applied process pressure (p_e / pabs) is transferred directly to the measuring diaphragm, whereas, in case of the silicon pressure sensor, the pressure is transferred via the separating diaphragm and the fill fluid to the measuring diaphragm. When using the ceramic pressure sensor, a minimal deflection of the measuring diaphragm changes the output voltage of the pick-up system. In the silicon pressure sensor, the resistance values of four piezo-resistors doped in the measuring diaphragm will change which causes a change of the output voltage. This pressure-proportional output voltage is converted by means of the electronic matching unit and the amplifier into an electrical signal.

Depending on the model, the transmitter is connected to the process by means of a spigot G 1/2 (DIN EN 837), 1/2 - 14 NPT male or female thread, front-bonded diaphragm with special thread G 1/2 for, e.g., ball valve connection or remote seal.

The transmitter operates with a 2-wire system. The same wires are used for the operating voltage (depending on the transmitter, see section 10 "Technical Data") and the output signal (4...20 mA or digital). The electrical connection is made via cable entry or plug.

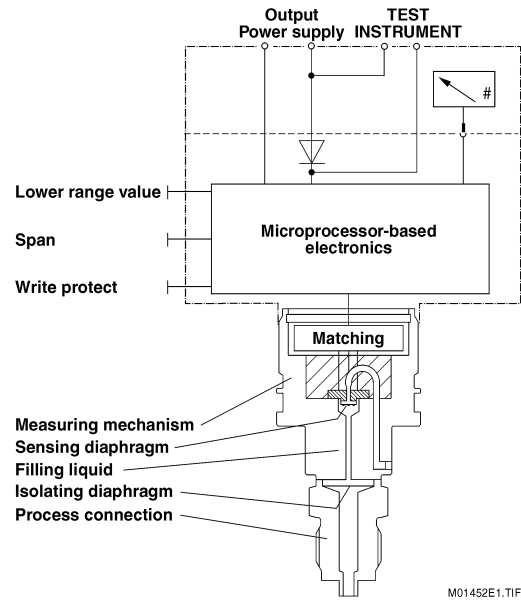

Figure 1. Transmitter 2020TG for gauge pressure and level (Measuring ranges ≥ 2.5 bar)

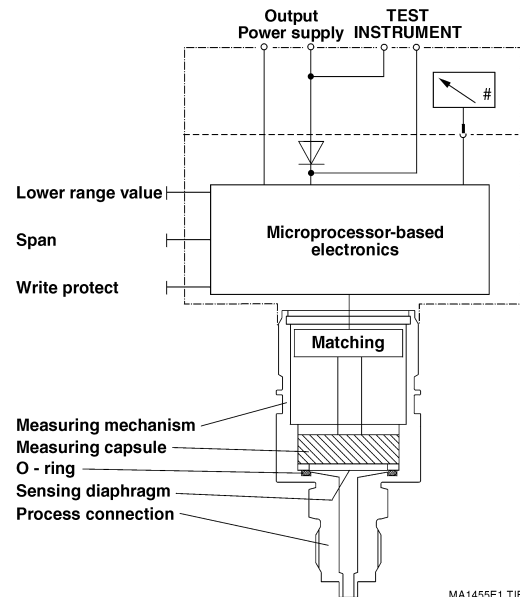

Figure 2. Transmitter 2020TA for absolute pressure (Measuring ranges ≤ 400 mbar abs.)

In case of HART® / Bailey FSK devices, the output signal 4...20 mA can be measured at the "TEST" sockets without interrupting the signal circuit (not applicable in case of fieldbus devices!). A fixing possibility is provided for a stainless steel tie-on plate indicating the tag number.

Lower range value and upper range value can be set by means of "local" keys (optional, can be retrofitted) and, if required, the keys can be interlocked with the write protect switch.

The transmitter may be equipped with an LCD indicator which can be read from the front (optional, can be retrofitted).

In conjunction with the LCD indicator, a complete external parameter setting and configuration of the transmitter is possible via the "local" control unit (see section 7 "Operation").

Documentation

Supplementary documentation:

Instructions 42/15-710 EN

For device construction, detailed operation, assembly examples

4 Mounting

General

Before mounting the transmitter, check whether the model meets the measurement and safety requirements of the measuring point, e.g. with regard to materials, pressure rating, temperature, explosion protection and operating voltage. The relevant recommendations, regulations, standards and the rules for prevention of accidents must also be observed! (e.g. VDE/ VDI 3512, DIN 19210, VBG, Elex V, etc.)

Measurement accuracy is largely dependent upon correct installation of the transmitter and the related measurement piping. The measuring set-up should be screened as much as possible from critical ambient conditions such as major temperature variations, vibration and shock. If unfavorable ambient conditions cannot be avoided owing to reasons related to building structure, measuring requirements or other reasons, this may influence the measurement quality! (see section 10 "Technical Data").

If a remote seal with capillary tube is attached to the transmitter, see also the Instructions 42/15-813 EN.

Transmitter

The transmitter can be connected directly onto the shut-off valve. There is also a mounting bracket for wall or pipe mounting (2" pipe) available as an accessory.

The transmitter should be installed preferably in a vertical position. **Please refer to section 11 "Dimensional Diagrams" for possible mounting with bracket.**

Measuring piping

The following points must be observed for correct installation:

- Keep the measurement piping as short as possible and avoid sharp bends.
- Lay the measurement piping so that no deposits can accumulate. Gradients should not be less than 8 %.
- Measurement piping should be blown through with compressed air or, better still, flushed through with the measuring medium before connecting to the measuring element.
- Completely bleed measurement piping if the medium is a liquid.
- Lay the measurement piping so that gas bubbles, when measuring liquids, or condensate when measuring gases, can flow back into the process piping.
- Take care of the tightness of the connection.

5 Electrical Connection

The relevant guidelines must be observed during the electrical installation!

Since the transmitter has no switch-off elements, overcurrent protection devices or mains disconnection possibilities must be provided on the system side. (Overvoltage protection at option)

Check that the existing operating voltage corresponds to that indicated on the type plate.

For power supply and output signal, the same lines are used. **Consult the enclosed connection diagram!**

Depending on the supplied model, the electrical connection is made via cable entry 1/2-14 NPT or M 20 x 1.5 or via plug Han 8 U. The screw terminals are suitable for wire cross-sections up to 2.5 mm².

Caution: For transmitters of category 3 regarding the application in "Zone 2" the cable gland has to be provided by the customer. For this purpose there is a thread of size M 20 x 1.5 in the electronic housing. The cable gland must comply with the protection type "In-

creased Safety EEx e" according to the directions 94/9/EG (AT-EX). Furthermore, the conditions stated in the type test certificate of the cable gland have to be observed!

Note: If the type of protection "Flameproof enclosure" (EEx d) applies to the transmitter, the enclosure cover has to be locked by means of the attachment screw (Fig. 3).

We would like to point out here that after intervals of several weeks an increased force is required to screw off the housing. This effect is not caused by the thread but only due to the gasket type.

Electrical connection in the cable connection compartment

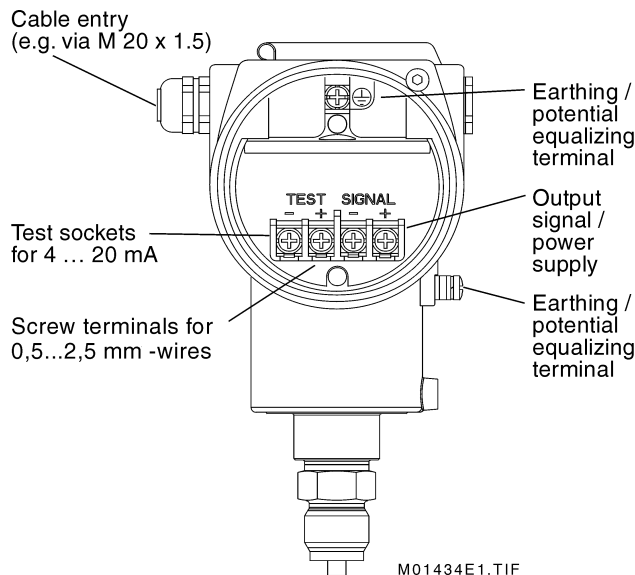

Figure 3. Cable connection compartment

Electrical connection with plug



Bild 4. Plug connection

Mounting of the socket connector

The socket connector for the cable connection is enclosed with the transmitter for the plug version.

Installation (see Fig. 5):

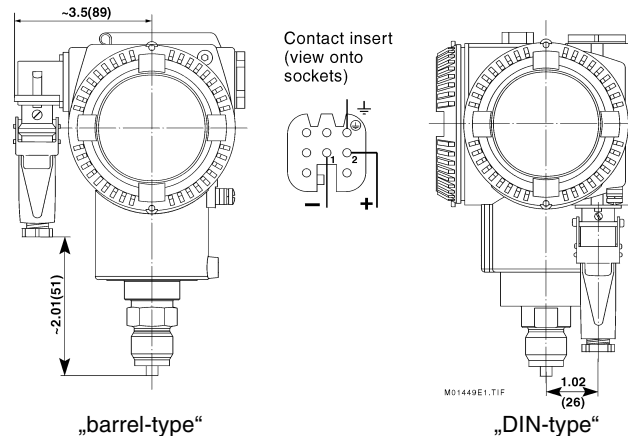
The contact sockets (2) are crimped or soldered onto the cable ends (wire cross-section 0.75...1 mm²) from which 1.5...2 cm of the sheath and about 8 mm of the insulation has been removed and inserted from the rear into the contact insert (1). The screwed gland (5), thrust ring (7), sealing ring (4) and grommet housing (3) must be pushed onto the cable in the specified order prior to installation (the sealing ring (4) may have to be adapted to the cable diameter first).

Attention:

Check the connecting points again before pressing the sockets all the way into the contact insert. Incorrectly installed sockets can only be removed again with a special removal tool (item no.: 0949 813).

A connection terminal is available for grounding (PE) on the transmitter exterior and also in the plug. Both terminals are electrically interconnected.

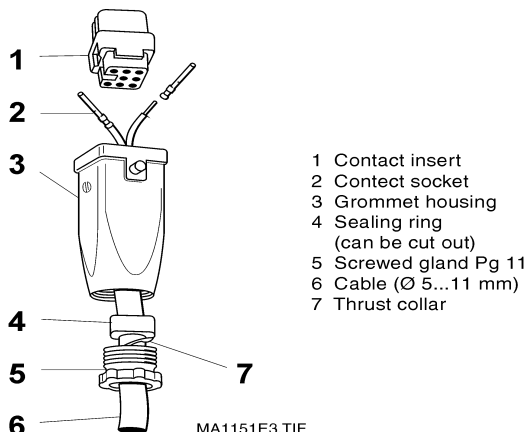

Figure 5. Mounting of the socket connector

Protective conductor / grounding

The transmitter operates within the specified accuracy with common mode voltages between the signal lines and the housing up to 250 V.

On principle the power supply of the transmitter with an output voltage of max. 60 VDC has to be effected from a voltage source which is safely separated from mains. In order to fulfill the requirements of the low-voltage guidelines and the relevant EN 61010 rules for the installation of electrical components, the housing must be provided with a protective circuit (e.g. grounding, protective conductor) if voltages of > 60 V could occur.

Set-up of the signal circuit / communication circuit for transmitters with 4...20 mA output signal (HART® / Bailey FSK protocol)

The transmitter can be operated via a modem by means of a PC or laptop. The modem can be connected in parallel to the transmitter at any place in the signal circuit. Communication between transmitter and modem is made via AC signals which are overlaid to the analog 4...20 mA output signal. This modulation is effected without averaging and therefore, it does not influence the measuring signal.

Communication between transmitter and PC or laptop is only possible if the signal circuit is set up as shown in Fig. 6. The resistance between the connecting point of the FSK modem and the power supply must be at least 250 ohm including the internal resistance of the supply unit. If this value is not reached with the normal installation, an additional resistance must be used.

The additional resistance has already been installed by the manufacturer in the supply units TZN 128 and TZN 129.

In the "FSK bus" mode, the TZN 128 allows to communicate directly via the supply unit.

For power supply, either supply units, batteries or power packs can be used which must be designed to ensure that the operating voltage UB of the transmitter is always between 10.5 and 45 V DC (for LCD indicator 14 ... 45 V DC).

The max. current of 20... 22.5 mA which may occur by overranging according to the respective parameter setting, must be taken into account. The minimum value for US results from this. If further signal receivers (e.g. indicators) are connected into the signal circuit, their resistance must also be taken into account.

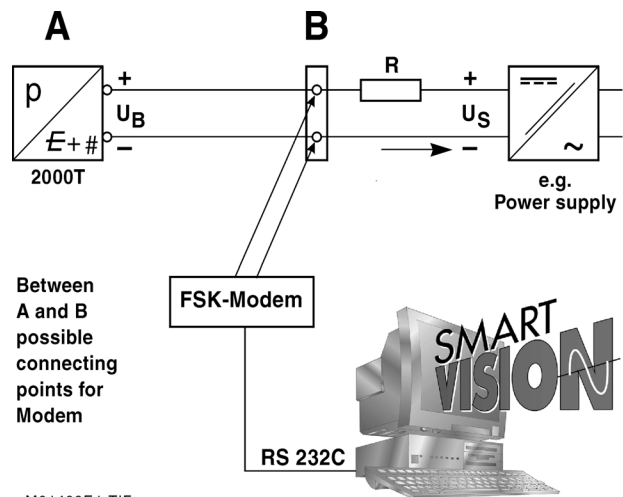

Figure 6. Communication mode: "point-to-point"

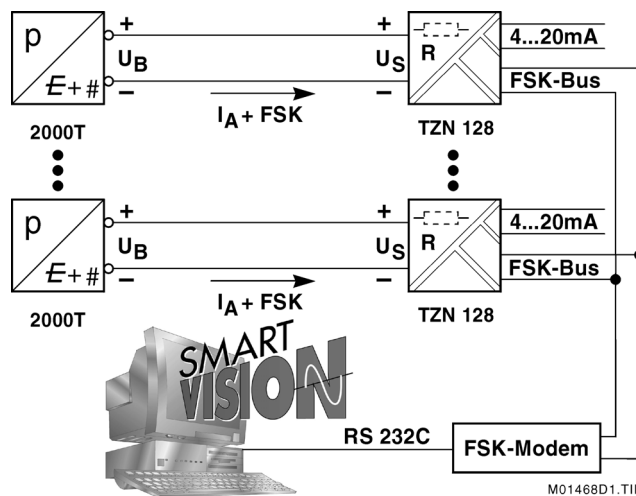

Figure 7. Communication mode: "FSK bus"

Notes on connecting cable

To allow communication between transmitter and PC/laptop, cabling must meet the following requirements:

It is recommended to use shielded and twisted pair lines.

The minimum wire diameter should be:

- 0.51 mm for lines up to 1500 m
- 0.81 mm for lines longer than 1500 m

The maximum line length is limited to:

- 3000 m for twin-core cable
- 1500 m for multicore cable

The actually possible line length of the electric circuit depends on the total capacitance and joint resistance; it can be estimated according to the following formula:

$$L = \frac{65 \times 10^6}{R \times C} - \frac{C_f + 10000}{C}$$

- L = Line length in m
- R = Joint resistance in
- C = Line capacitance in pF
- Cf = Capacitance of the devices existing within the circuit

The shield should be grounded on one side only. Laying together with other electric circuits (with inductive load, etc.) and the proximity of large electrical installations should be avoided.

Max. permissible residual ripple of the supply voltage during communication:

- 7 V_{ss} at 50 Hz ≤ f ≤ 100 Hz
- 1 V_{ss} at 100 Hz < f ≤ 200 Hz
- 0.2 V_{ss} at 200 Hz < f ≤ 300 Hz

Notes on PROFIBUS-PA transmitters

Fieldbus transmitters are provided for the connection to segment couplers DP/PA. The permissible terminal voltage ranges from 10.2... 32 V DC. Current consumption is 14 mA (at average transmission).

A shielded cable is recommended. Contacting of the shield is effected in the metal screwing. The transmitter must be grounded. The transient behavior corresponds to the draft DIN IEC 65C / 155 / CDV dated June 1996. When operating with an Ex-segment coupler according to DIN EN 61 158-2 October 1994, the max. number of devices may be reduced by a time-dependent current limitation. The output signal of the transmitter is transferred digitally according to IEC 61158-2. For PROFIBUS-PA, the communication protocol corresponds to Version 3.0, Class B, Ident-No.: 04C2 HEX (EN 50 170).

During cyclic data traffic, the OUT variable is transmitted. It is composed of the output value and 1 byte status information. The output value is transmitted with 4 bytes as IEEE-754 Floating-Point-Type. Further notes on PROFIBUS-PA, e.g. with respect to the "Ident Number", are given in the "Additional Instructions 42/15-712-Z0.20", the data sheet "Installation Suggestions 10/63-0.40" as well as under the Internet address <http://www.profibus.com>.

Notes on explosion protection

For the installation (electrical connection, grounding / potential equalization, etc) of explosion-proof transmitters, the national statutory orders, DIN/VDE rules, guidelines for explosion protection and the explosion proofness test certificate of the device have to be observed. The certified explosion proofness of the transmitter is indicated on the type plate.

Transmitters of the type of protection "Intrinsically safe EEx i" according to the directions 94 / 9 / EG (ATEX):

- Install only intrinsically safe devices within the transmitter signal circuit.
- The signal circuit may be interrupted even when the transmitter is in operation (e.g. disconnect and connect signal lines).
- The housing may be opened during operation.
- Transmitters with and without remote seal of the protection type "Intrinsically Safe EEx i" and ranges **60 / 400 mbar** may be installed **directly** at Zone 0 if the power supply is effected via an intrinsically safe circuit **EEx ia**.
- Transmitters with and without remote seal of the protection type "Intrinsically Safe EEx i" and ranges **≥ 2.5 bar** may be installed **directly** at Zone 0 if the power supply is effected via an intrinsically safe circuit **EEx ia or EEx ib**.
- Test circuit (terminals "TEST +/-"): in protection type Intrinsically Safe only for connection to passive intrinsically safe circuits. The category, the explosion class as well as the max. values U₀, I₀ and P₀ of the intrinsically safe test circuit are determined by the connected intrinsically safe signal circuit. The rules for interconnection have to be observed!

Transmitters of category 3 for the application in "Zone 2" according to the directions 94 / 9 / EG (ATEX):

- The transmitter has to be connected via the approved cable gland (protection type "Increased Safety EEx e" according to ATEX).
- It is not permitted to open the housing during operation (operating voltage switched on)!

Transmitters of the type of protection "flameproof enclosure EEx d" according to the directions 94 / 9 / EG (ATEX):

- It is not permitted to open the housing during operation (operating voltage switched on)!
- The following set-up instructions have to be observed:
 1. The transmitter has to be connected via suitable cable and line entries or piping systems which meet the requirements according to EN 50 018:1994, Section 13.1 and/or 13.2 and for which a separate test certificate is available!
 2. Unused openings of the housing have to be closed according to EN 50 018:1994, Section 11.9!
 3. Cable and line entries as well as blanking plugs which do not correspond to the points 1. and 2. must not be used!
- To align the transmitter (torsion by max. 360°) at the measuring point, the rotatable housing can be loosened at the shaft between sensor and housing:
 - Release the attachment screw by max. 1 rotation.
 - Align the housing.
 - Retighten the attachment screw!
- Before switching on the operating voltage:
 - Close the housing.
 - Secure enclosure cover by turning the attachment screw (hexagon socket screw) to the left.
 - Protect housing from torsion by turning the attachment screw (stud) to the right.
- Enclosure cover, electronic housing and sensor may only be replaced by approved components!

Type test certificate / Conformity statement

For transmitters in explosion-proof design the EC type test certificate and / or the conformity statement have to be considered as part of these operating instructions.

6 Commissioning

After installing the transmitter, it is placed into operation by switching on the operating voltage.

- Check the following before switching on the operating voltage:
 - Process connections.
 - Electrical connections.
 - That the measurement piping and measuring chamber of the transmitter are completely filled with the medium.
- Subsequently it is placed into operation.
The shut-off valves should be operated in the following sequence (basic setting: all valves closed):
 1. Open the shut-off valve at pressure tapping point – if present.
 2. Open the shut-off valve.
- Proceed in the reverse order when taking the unit out of operation.

Regarding the 2020TA for absolute pressure with a measuring ranges ≤ 400 mbar abs. it has to be observed that during transportation and storage the sensor has been overloaded by the atmospheric pressure for a long time. Due to this, a starting time of approx. 3h is necessary after commissioning until the sensor is stabilized so that the specified accuracy is kept.

If, in case of transmitters of the type of protection "Intrinsically safe", a current meter is connected to the test sockets or a modem is connected in parallel when an explosion hazard is existing, the sums of the capacitance and inductance of all circuits including transmitter (see type plate) must be equal to or smaller than the permissible capacitance and inductance of the intrinsically safe signal circuit (see type plate of the supply unit). Only passive or explosion-proof test devices or indicators may be connected. If the output signal is slow to stabilize, a high damping time constant has probably been set in the transmitter.

Notes on transmitters with 4...20 mA output signal (HART® / Bailey FSK protocol)

If the applied pressure is within the values indicated on the type plate, the output current ranges between 4 and 20 mA. If the applied pressure exceeds the calibrated range, the output current is between 3.5 mA and 4 mA in case of underranging or between 20 mA and 22.5 mA (according to the respective parameter setting) in case of overranging; standard setting: 3.8 mA / 20.5 mA. A current of < 4 mA or > 20 mA may also indicate that the micro-processor has detected an internal error; standard setting: 21 mA. Via the communication tool SMART VISION, an exact diagnosis of the error can be performed. A short-time interruption of power supply results in an initialization of the electronic (restart of the program).

Write protection

Write protection prevents an illegal overwriting of the configuration data. If write protection is activated, the function of the keys 0 % and 100 % is disabled. However, it is still possible to read out the configuration data by means of SMART VISION (or another comparable communication tool).

If necessary, the control unit can be leaded.

Write protection is activated as follows (see also symbolism on the plate):

1. First, fully press down the switch with an appropriate screw driver.
2. Then turn the switch clockwise by 90° .

For deactivation the switch has to be pushed down a little and turned counterclockwise by 90° .

Oblique sensor/ zero correction

During the installation of the transmitter, zero shifts (e.g. additional remote seals etc.) caused by mounting may occur which have to be corrected.

Note: The transmitter must have reached its operating temperature (approx. 5 min after switch-on if the transmitter has already assumed ambient temperature) in order to be able to carry out the zero check. The correction has to be made at $pe = 0 / pabs = 0$! There are two possibilities (point 1A or 1B) to perform the **4...20 mA-output signal** correction directly at the transmitter (control unit is available):

1A. Apply pressure at lower range value (4 mA) – from the process or from a pressure pick-off. The pressure must be stable and applied with high accuracy $<< 0.05\%$ (observe adjusted damping). Press the 0 % key at the transmitter – output signal is adjusted to 4 mA. The span remains unchanged.

Subsequent to the last actuation of the 0% key, the non-volatile storing of the lower range value adjusted in this way is effected after

- $< 25s$ for HART and/or
- $< 110s$ for PROFIBUS-PA and/or
- $< 15s$ for FOUNDATION Fieldbus.

1B. In conjunction with an installed LCD indicator, call up the menu item "SHIFTZERO" via the keys "M" and "+". Corrections are made by pressing the key "M" (see also section 7 "Operation").

2. Subsequently put the transmitter into the operating state. The above procedure acc. to "1A" has no influence on the display of the physical differential pressure, but instead corrects the analogue output signal. Therefore, a difference may occur between the analogue output signal and the display of the physical differential pressure on the digital display or the SMART VISION communication tool. In order to avoid this difference, the necessary zero-point shift must be carried out using the SMART VISION (menu path **Configure Pressure Measurement Process Variable** (Oblique Sensor)). **However, then a zero-point shift must not have been carried out with the 0% key beforehand.**

Rotate housing with regard to the sensor

The electronic housing can be rotated through 360° and can be fixed in any position. A stop prevents the housing from being turned too far.

To this effect, the fixing screw at the housing shaft (hexagon socket screw SW 2.5mm, see section 11 "Dimensional Diagrams") must be released and hand-tightened after the position has been reached.

Assembly / disassembly of push button unit (Figure 7)

- Loosen the screw of the protective cap and turn it aside.
- Push the lock completely out of the push button unit, e.g. by means of a suitable screw driver.
- Remove the uncovered square nut from the push button unit.
- Loosen the fixing screw of the push button unit by a Torx screw driver (size T10) and pull the latter out of the electronic housing.
- If necessary, insert a spacer and tighten it by the attached screw.

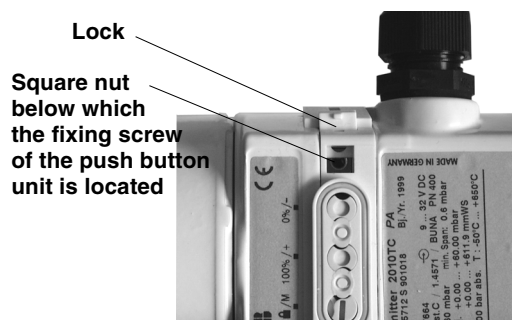

Figure 8. Push button unit - disassembly / assembly

Mount LCD indicator

- Unscrew enclosure cover of the electronic compartment (see figure 9) (if necessary, observe section "Secure enclosure cover for EEx d").

- Plug LCD indicator.
Depending on the mounting position of the transmitter, the LCD indicator can be slipped on in four different positions; in this way turns by $\pm 90^\circ$ or $\pm 180^\circ$ are possible.
Note: If the LCD indicator is backlit (option), there is a three-core cable with plug on the back of the indicator. Connect this plug with the three-pole plug strip in the electronic compartment (see Fig. 8) before slipping on the indicator. If there is a jumper on the 3-pole plug strip (in case of fieldbus transmitters no jumper is existing), it has to be removed and plugged into the "socket for jumper".
- Fasten LCD indicator with both screws.
- Hand-screw the enclosure cover (if necessary, observe section "Secure enclosure cover for EEx d").

Position of jumper,
if the LCD indicator is not backlit
and / or

3-pole plug strip
for backlit LCD indicator

Socket for jumper,
for backlit LCD indicator

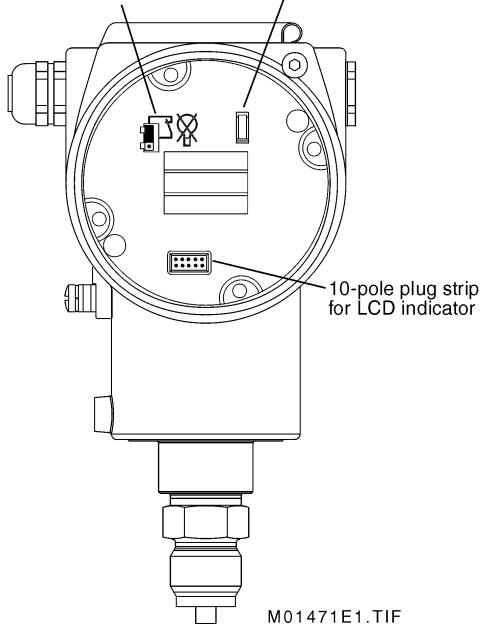

Figure 9. Electronic compartment – LCD indicator mounting

Secure enclosure cover for EEx d

On the top right of the electronic housing front, there is an attachment screw (hexagon socket screw, SW 3mm).

Attachment screw

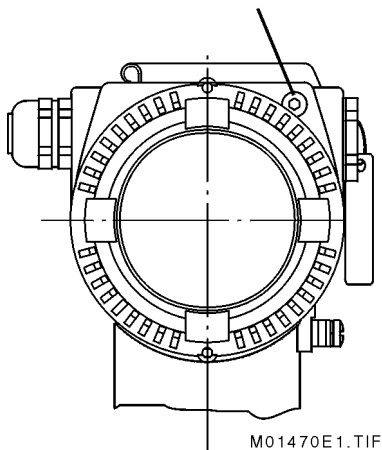
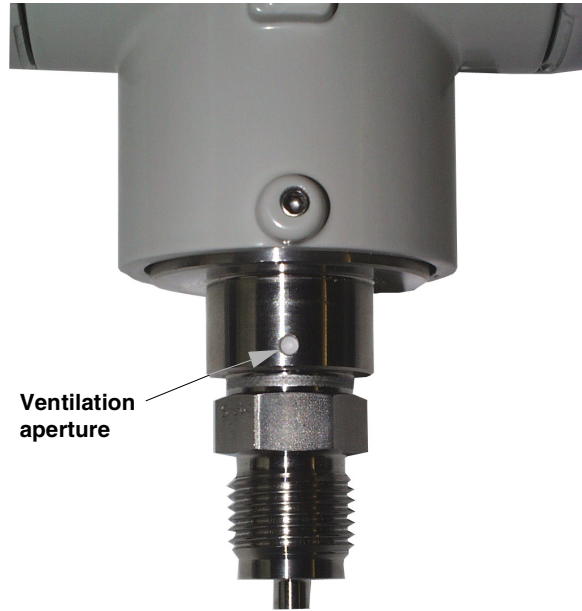

Figure 10. Secure enclosure cover

- Turn enclosure cover hand-tight into the housing.
- Secure enclosure cover by turning the attachment screw to the left. In doing so the screw must be unscrewed to the stop of the screw head at the housing cover.

Ventilation aperture for 2020TG with ranges $\leq 30\text{bar}$



For measurement reasons it is necessary to apply atmospheric pressure to the reference side of the pressure sensor. For this purpose there is a **ventilation aperture** at the outside of the sensor which is protected by a PTFE filter. Therefore, it has to be taken care that the ventilation aperture is not covered (e.g. painting is not allowed).

7 Operation

⚠ There is no protection against electric shock when the housing covers are open. Do not touch live parts.



Figure 11. Key legend plate

Operation with "local keys" (at the device) without LCD indicator

The retrofit / optional control unit comprises 2 keys for external adjustment of lower range value (0 %) and upper range value (100 %) and a write protect switch. There are no physical connections through the housing for the keys and the switch.

Calibration

Lower range value and span may be adjusted directly at the transmitter via keys.

The transmitter has been calibrated by the manufacturer according to the order data. The set values for lower range and upper range are indicated on the type plate.

Generally the following applies:

The 1st pressure value (e.g. 0 mbar) is always assigned to the 4 mA signal and the 2nd pressure value (e.g. 400 mbar) always to the 20 mA signal.

To readjust the transmitter, apply the pressure for the lower and upper range value to the sensor. Make sure that the measuring limits are not exceeded.

Pressure reducing stations with adjustable pressure and comparative displays can be used as sensors. When connecting, take care to avoid residual liquids (with gaseous test media) or air bubbles (with liquid test media) in the piping since they can cause errors.

The pressure reducing station should have an accuracy of at least 3 times better than the transmitter to be tested.

It is advisable (adjusted time constant is known!) to set the damping to zero (via key plus LCD indicator or SMART VISION).

Regarding the 2020TA for absolute pressure with a measuring ranges ≤ 400 mbar abs. it has to be observed that during transportation and storage the sensor has been overloaded by the atmospheric pressure for a long time. Due to this, a starting time of approx. 3h is necessary after commissioning until the sensor is stabilized so that the specified accuracy is kept.

Sequence of steps:

1. Apply pressure for lower range value and wait approx. 30 s until it has stabilized.
2. Press key 0 % - output current is set to 4 mA.
3. Apply pressure for upper range value and wait approx. 30 s until it has stabilized.
4. Press key 100 % - output current is set to 20 mA.
5. If necessary, reset damping to the initial value.
6. Document new settings.

10 s after the last actuation of the 0 % or 100 % keys, the respective parameter is stored in a failsafe way.

This procedure of adjustment only changes the **4...20 mA** current signal. The representation of the physical process pressure on the digital display or by means of a communication tool, e.g. SMART VISION, is not changed. To avoid this difference, a correction can be made via the communication tool SMART VISION and its menu path **Calibrate_Pressure Measurement_Adjust Input**.

After such a correction, the calibration of the device must be checked.

Operation with

"local keys" (at the device) with LCD indicator

In conjunction with an LCD indicator, the transmitter can be configured with the keys (- / + / M) as follows:

(Note: Indications in () designate the menu item, they are shown in the 1st and 2nd line of the indicator.)

- Exit the menu (EXIT)
- View selected measured and calculated values (VIEW)
- Lower range value with applied pressure (GET 0%)
- Upper range value with applied pressure (GET 100%)
- Lower range value without applied pressure (SET 0%)
- Upper range value without applied pressure (SET 100%)
- Correct zero drift (e.g. oblique sensor) (SHIFTZERO)
- Parallel shift (OFFSET SHIFT)
- Scaling output variable – initial value (OUT 0%)
- Scaling output variable – final value (OUT 100%)
- Damping (DAMPING)
- Output current in case of an error (ALARM CURRENT); only available for 4...20 mA devices with HART® or Bailey FSK protocol
- Displayed value (DISPLAY)
- Pressure unit (UNIT)
- Temperature unit (UNIT) of internal temperature sensor
- Characteristic (FUNCTION) and the
- Fieldbus address (ADDRESS); only available for devices with PROFIBUS-PA or FOUNDATION Fieldbus protocol.

In the following, some of the a.m. menu items are described in detail.

Notes on "Parallel shift (OFFSET SHIFT)"

This function performs a parallel shift of the characteristic so that it runs through a specified point. Thus, the output signal of several measuring devices which measure the same process variable, can be brought to the same value without carrying out calibration with applied pressure.

On certain conditions, the function may be performed at any point of the characteristic:

- Process variable within the adjusted measuring range
- Transmitter with linear transfer function

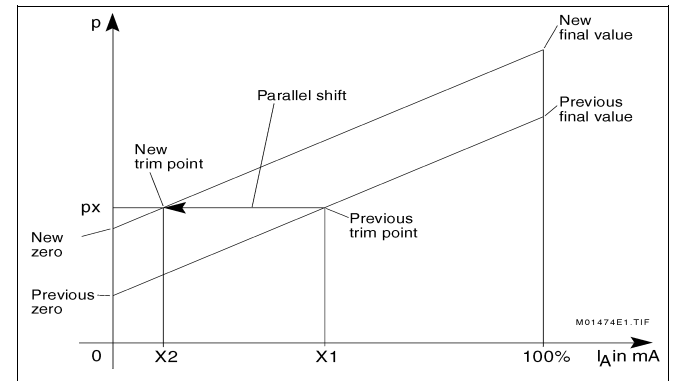

Figure 12. Parallel shift

Comments on Fig. 12:

By entering a percent value, an offset shift of the measuring range is carried out.

The transmitter displays with applied pressure p_x the standardized output value x_1 in percent. However, for the present application, the value x_2 should be displayed. Now the value x_2 is set via local operation. The transmitter calculates the new zero and the new final value and then assumes these new settings.

Notes on "Damping (DAMPING)"

A fluctuating output signal of the transmitter, caused by the process, can be electrically smoothed (damped).

The additional time constants is adjustable between 0 sec. and 60 sec. in stepwise of 0.001s.

The damping set in this way does not affect the digitally indicated value in physical units, only the derivatives such as analogue output current, free process variable, input signal for controller etc.

Notes on "Characteristic (FUNCTION)"

In this menu option you can select the functions: linear and freely programmable. The "individual values of the freely programmable characteristic" cannot be changed here. A Hand-Held-Terminal or the communication tool SMART VISION has to be used for changes.

Notes on "Fieldbus address (ADDRESS)"

Under this path, the fieldbus-slave-address may be changed. Enter a figure between 0 and 126 for the selected transmitter.

Remark: Generally, the manufacturer assigns the address 126 to all new devices! The transmitters should get different addresses in order to allow the addressing of a specific device. If, e.g., the device data are loaded via the communication tool SMART VISION after the address has been changed, the connection set-up is executed again, and possibly an error message appears. Acknowledge this with "Repeat", then the data will be loaded without any problem.

Measured value display

● The LCD indicator

2-line, 7-character, 19-segment alphanumeric display with additional bar chart display. Optionally the indicator is available with back illumination.

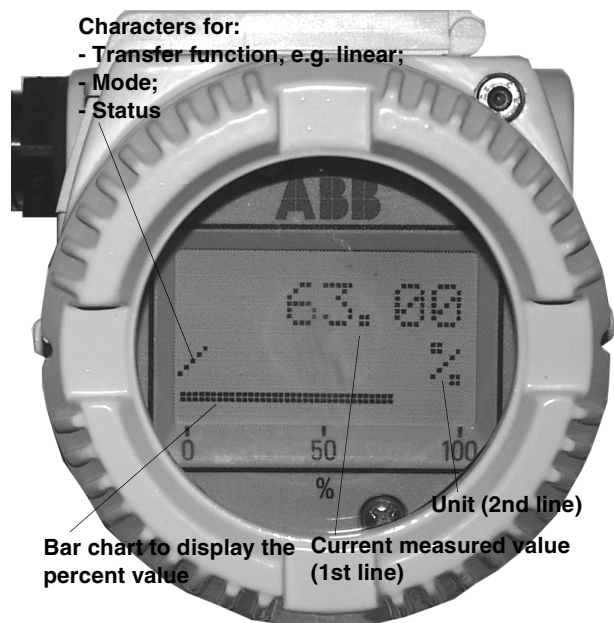

Figure 13. LCD indicator (optional)

● Display of the physical value

At the first position of the first line, the sign is displayed. The following six positions show the amount of the measured value. The comma is placed in such a way that the maximum value can be displayed with these six positions. The place of the comma is not changed. A comma at the sixth position is not displayed. Thus it is possible to display max. +/-999999. If this value is exceeded **Overflow** is indicated. In the second line, the unit is displayed with the last five positions. The first position shows the following characters, if necessary, one after the other. Display changes every second.

Display for	Character	Comment
Transfer function	√, √ or √	Always one of these characters appears.
Write protection	⊞	Only if write protection has been set.
Cyclic communication	...	Only in case of PROFIBUS-PA
Status available (e.g. measuring range infringement or hardware error)	⊞	Only if a status is available.
Code of displayed value	1. . . 9	See menu Display (see structure tree)
Transmitter is busy	0	This character overwrites other characters.

Table 1: Legend

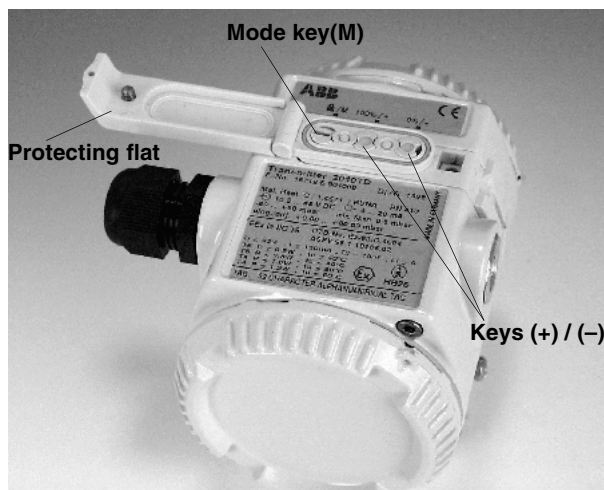

Figure 14. Control elements (optional)

Display of the percent value

	Display on LCD indicator
1 st line	Percent value, limits: -25% to 125%, 2 decimal places
2 nd line	1 st position: Transfer function (Table 1) 2 nd position: Write protection (Table 1) 7 th position: %
Bar chart	2% steps - from -2% to +10%, no hysteresis

Table 2: Percent value display on LCD indicator

Program control

To make the keys accessible, release the screw and turn the protection cap aside (see Figure 13). With the mode key "M", you can start menu-controlled programming. To call the next menu item, press the key "+". You will return via the key "-". Sub-menu items / selection lists are activated via the mode key "M". A numerical value can only be changed via the keys "+" and "-". It must be taken into account that the key "+" changes the value (each keystroke increases the value by 1), whereas the position of the value to be changed is reached via the key "-". Acknowledge changes with the mode key "M"; the subsequent OK acknowledgement (via the key "M", "+" or "-") writes the new value into the failsafe storage. An adjusting process can be aborted by pressing simultaneously the keys "+" and "-". From any main menu item, you can return to the menu item "EXIT" by simultaneously pressing the "+" and "-" keys. When the adjustment has been finished, quit the program via the menu item "EXIT". By means of the following structure tree, you will get an overview of the selection / programming possibilities.

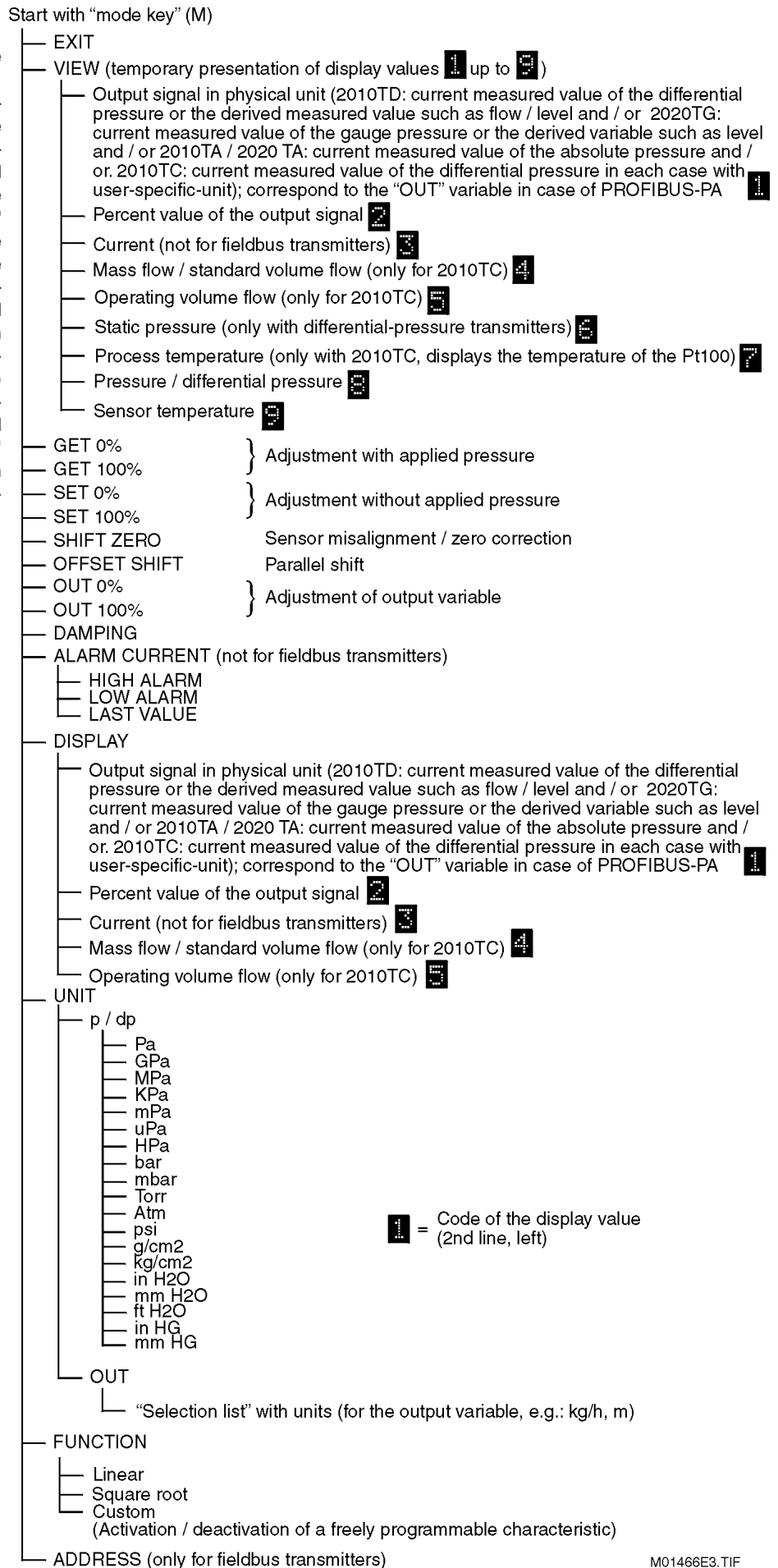

Figure 15. Structure tree

M01466E3.TIF

Operation with PC / Laptop or Handheld terminal

To configure the transmitter via PC / laptop, the software SMART VISION is required. Please refer to the software description for operating instructions.

Communication protocol: PROFIBUS-PA® or
Foundation Fieldbus® or
HART® or Bailey FSK
Hardware: for HART® and Bailey FSK:
FSK modem for PC / notebook
Handheld Terminal: STT 04 or HHT 275

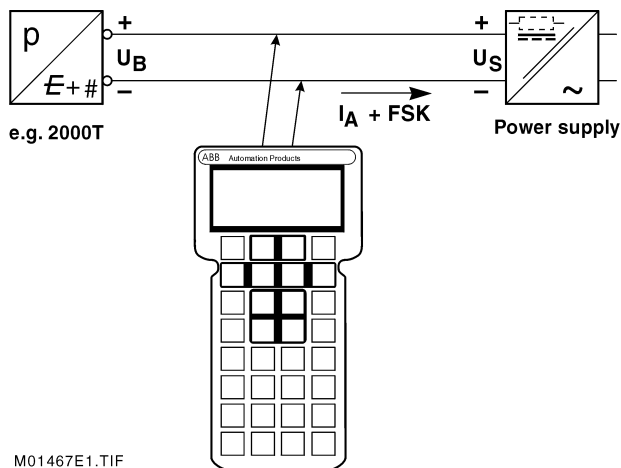

Figure 16. Communication set-up via STT04

Configuration of the flow measurement with SMART VISION

If the transmitter has been configured at the manufacturer's work for the measuring point according to the specifications given in the questionnaire you do not have to do anything else than to assemble the transmitter as specified (perhaps correct the oblique sensor -refer to command: **Configure Pressure Measurement Process Variable** (Oblique Sensor)). After switch on the measuring point is ready for operation. If the transmitter is equipped with an LCD indicator, the current differential pressure (default adjustment) is displayed immediately.

However, if you want to make changes e.g. concerning the configuration of the mass flow measurement, you need a communication tool, e.g. SMART VISION. By means of this tool the device can be configured completely. It supports the HART Protocol as well as the fieldbus protocols "PROFIBUS-PA and FOUNDATION Fieldbus" and is operable on a PC / Notebook and/or in an automation system.

The necessary operating steps for the installation of SMART VISION are described in the installation instructions delivered with the software. The parameters can be adjusted via the path **Configuration_Pressure Measurement**.

The program offers the possibility to configure, to set parameters, to interrogate and to test the devices. Furthermore an OFF-line configuration can be carried out via an internal data management. Every parameter setting and configuration is subjected to a plausibility check.

The <F1> key provides extensive context-sensitive help at every stage throughout the complete program.

Attention: Immediately after the delivery of the transmitters and/or before changing the configuration we recommend to save the existing configuration data on a data medium using the command **File_Save**.

Operation via SMART VISION®

System requirements

- SMART VISION®
SMART VISION® as from Version 4.00.31
When installing the DTM (Device Type Manager), SMART VISION® is updated to Version 4.00.43.
- Operating systems
 - Windows NT 4.0
 - Internet Explorer as from Version 5.0

Note:

The DTM is started by means of the right mouse button or via the menu item "Device" with "Edit". After a "Connection setup", first the data of the 2020TG/TA should be loaded completely. Changed data are underlined and displayed in blue. These data are transmitted to the device via "Store data in the device".

After the data have been saved in the transmitter, their nonvolatile storage is effected automatically. To do this, power supply to the transmitter must be continued for 2 minutes. If this is not observed, the previous data will become active again during the next operation. In case of software versions < 0.20 (< 20 for HART), storage will only be effected after disconnection.

For Profibus devices, the disconnection of "Local operation" only becomes effective in case of cyclic communication. If write protection is set by means of the DTM, the setting of the 2020TG/TA can no more changed via the control keys.

For Profibus devices, the slave address must be indicated correctly in the project tree of SMART VISION®. Communication name and description are automatically updated when loading the device data.

The most important calibration / parameterization possibilities under SMART VISION® are shortly described in the following. You will find further notes on the menu items in the context-sensitive help. Before carrying out any setting, please ensure that write protection has neither been activated on the transmitter itself (key ) or via SMART VISION® (menu path **Configuration_Basic Parameters_General_Local Operation**).

● Adjust damping

Menu path:

Configuration_Pressure Measurement_Output

The required value has to be entered in the field "Output parameters" in the line "Damping".

● Correct oblique sensor

Menu path:

Configuration_Pressure Measurement_Process Variable

Actuate the button <Balance> in the field "Oblique sensorment". Balancing is immediately effected with nonvolatile storage in the transmitter.

● Adjust lower and upper range value

Menu path:

Configuration_Pressure Measurement_Process Variable

In the field "Scaling", the adjustment is possible in two ways:

- **Value input:** The required value / values has / have to be entered in the input fields "Lower range value" and / or "Upper range value".

or

- **Process pressure acceptance:** For the adjustment, the lower range value and the upper range value are preset as pressure at the sensor. Make sure that the measuring limits are not exceeded. Pressure reducing stations with adjustable pressure and comparative displays can be used as sensors. When connecting, take care to avoid residual liquids (with gaseous test media) or air bubbles (with liquid test media) in the piping since they can cause errors. The pressure reducing station should have an accuracy of at least 3 times better than the transmitter to be tested.

8 Maintenance

The transmitter is maintenance-free.

It is sufficient to check the output signal – depending on the operating conditions - at regular intervals according to section 7 "Operation".

If deposits in the sensor are to be expected, the sensor should also be cleaned at regular intervals – depending on the operating conditions. Cleaning should preferably be carried out in the workshop. If a remote seal is attached to the sensor, it must not be dismounted!

Replace defective transmitters/units according to the "Parts Data Sheet".

9 Repairs

Attention: Explosion-proof transmitters may only be repaired by the manufacturer, or they must be certified by an acknowledged expert after the repair has been carried out!

Observe the pertinent safety regulations before, during and after commissioning.

Disassemble the transmitter only to such extent as necessary for cleaning, checking, repairing and replacing the defective parts. Observe section 8 "Maintenance"!

Sensor as well as sensor with attached remote seal can only be repaired by the manufacturer.

If the electronic housing has to be detached from the sensor / the measuring cell, the electronic unit must be removed from the electronic housing before in order to prevent a damage to the electronic unit. For this purpose, first of all the housing cover has to be screwed off (attachment screw!, refer to figure 10), then remove a possibly existing LCD indicator from the electronic unit (loosen 2 screws), unscrew the two captive screws of the electronic unit and remove same carefully from the electronic housing. Detach the two plugs from the electronic unit (both plugs have got a mechanical reverse battery protection and the smaller one additionally a mechanical interlock: seize the plug on the front side between thumb and forefinger and press the lock towards the plug, then pull off the plug from the socket). Put the electronic unit on a suitable pad. Unscrew the electronic housing from the sensor / the measuring cell.

Return

Defective transmitters/units are to be sent to the repair department, if possible stating the fault and its cause.

Note: When ordering spare parts or instruments, please quote the serial number (F.-No.) of the original transmitter.

Address:

ABB Automation Systems GmbH
Department SWM
Schillerstraße 72
D-32425 Minden

10 Technical Data

Measured value

2020TG: Gauge Pressure

2020TA: Absolute Pressure

Measuring range (upper and lower range values)

Lower range value (continuously adjustable)

2020TG: - 100% (\geq -1bar) to + 100% of the URL

2020TA: 0% and + 100% of the URL

Upper range value (continuously adjustable)

Up to 100% of the URL

Spans

The adjusted span must not be lower than the minimum range.

Measuring ranges

Code	min.	max.
B	200 Pa / 2 mbar	6 kPa / 60 mbar
C	400 Pa / 4 mbar	40 kPa / 400 mbar
D	2.5 kPa / 25 mbar	250 kPa / 2.5 bar
F	30 kPa / 0.3 bar	3 MPa / 30 bar
G	100 kPa / 1 bar	10 MPa / 100 bar
H	600 kPa / 6 bar	60 MPa / 600 bar
K	200 Pa / 2 mbar abs.	6 kPa / 60 mbar abs.
L	400 Pa / 4 mbar abs.	40 kPa / 400 mbar abs.
M	2.5 kPa / 25 mbar abs.	250 kPa / 2.5 bar abs.
O	20 kPa / 0.2 bar abs.	2 MPa / 20 bar abs.

Output signal

Transmitters with 4...20mA

Signal: analogue 4 ... 20 mA

Output signal limits: Imin = 3.5 mA, Imax = 22.5 mA (configurable).

Standard setting: Imin = 3.8 mA, Imax = 20.5 mA

Alarm current

Min. alarm current: configurable from 3.5 mA to 4 mA, standard setting: 3.6 mA

Max. alarm current: configurable from 20 mA to 22.5 mA, standard setting: 21 mA

Standard setting: max. alarm current

Load

Transmitters with 4...20 mA

$$R \leq \frac{U_s - 10,5V}{I_{\max}} \text{ in kOhm}$$

I_{max} = 20 ... 22.5 mA (configurable)

U_s = supply voltage

min. power supply: 10.5 VDC, 14 VDC with backlit LCD-indicator

min. load for digital communications > 250 Ohm

Field Bus units

Signal: digital

Transmission technique: acc. to IEC 61158-2

Power supply: 10.2 VDC ... 32 V DC

Base current: 14 mA

Transmission rate: 31.25 kbits/s

PROFIBUS-PA: Version 3.0, Profile B for pressure transmitters; Ident No.: 04C2 HEX

Foundation Fieldbus: FF-890 / 891 ans FF-902 / 903

Characteristic

Linear, freely programmable with 20 reference points

Accuracy

Reference conditions

to DIN IEC 770

Temperature: 20 °C

Relative humidity: 65 %

Atmospheric pressure: 1013mbar (1013 hPa)

additional conditions:

Characteristic „linear output“ and transmitter with silicon pressure sensor: separating diaphragm material "Hastelloy C", fill fluid "silicone oil"

All specifications are limits and relate to the output range or calibrated range. The influences marked * relate to the measuring range (URL) and are to be multiplied by the turn down factor (ratio range (URL) / calibrated span). The turn down factor should be kept to a minimum.

Conformity

0.075 % ¹⁾

terminal based, including hysteresis and the dead band (optional 0.05 %)

Reproducibility

0.01 %

Hysteresis

0.05 %

Warm-up time

< 15 s

Rise time

The time behaviour of this transmitter is composed of the rise time of the sensor and an adjustable integration time constant of the A/D converter. A high time constant results into a high resolution, e.g. required for a high span ratio, and at the same time into a higher rise time for the output signal. A low time constant means a lower resolution, but a shorter rise time and thus a faster reaction time of the transmitter. In case of the default integration time constant the values shown in the table below result.

linear				freely programmable function
turn down factor				
≤ 1 : 10	> 1 : 10 up to ≤ 1 : 20	> 1 : 20 up to ≤ 1 : 40	> 1 : 40	
~ 0.3 s	~ 0.5 s	~ 0.9 s	~ 1.4 s	~ 0.5 s

additional adjustable time constant 0...60s

The effect appearing at the output for non-linear output depends on the function and is to be calculated accordingly.

Long-term drift

* 0.05% per 12 months

Ambient temperature effect

Thermal change (-40°C ... +80°C)²⁾

* on zero 0.1 %
on span 0.1 %

Temperature coefficient (-40°C ... +80°C)²⁾

* on zero 0.04 % per 10°C
on span 0.04 % per 10°C

Effect of electro-magnetic interference

* 0.05%

1) additionally with turn-down factor > 1:10
 $\pm(0.005 \times \frac{\text{measuring range}}{\text{adjusted span}} - 0.05)\%$

2) with carbon fluoride filling liquid: -20 °C ... +80 °C

Ambient conditions

Ambient temperature

-40 °C ... +85 °C (with O-ring Viton: -20 °C ... +85 °C),
Observe approvals for explosion-protected transmitters.

Storage temperature / transport temperature

-50 °C ... +85 °C, with LCD-indicator -40 °C ... +85 °C

Humidity

Relative humidity: ≤ 95% annual average
Condensation, icing: admissible

Protection class

IP 67 acc. to EN 60 529 (=NEMA Standard Type 6);
with Han 8U plug: IP 65 (=NEMA Standard Type 4X)

Protective varnish

epoxy resin, greywhite, RAL 9002

Shock resistant

Acceleration: 50g
Duration: 11ms

Vibration resistance

2g up to 1000 Hz, with amplifier housing made of "stainless steel" are valid restricted values (on request)

Electromagnetic compatibility (EMC)

to EN 50 082-2

Definition: Class 3

Radio suppression (EN 55 011): Limit class B

Fulfills NAMUR recommendation.

Process conditions

Temperature limits

-50 °C ... +120 °C, at process connection

to +400 °C in conjunction with remote seal.

with O-rings ranges: 60 mbar and 400 mbar)

- Viton (fluorocautchouc (FPM)) -20 °C ... +120 °C
- Perfluorelastomer (≡ PTFE): -15 °C ... +80 °C

Pressure limits

from vacuum up to maximum span

Overload limit

Ranges ≤ 400 mbar: 10 bar
• with O-ring perfluorelastomer: 6 bar abs.
Ranges 2.5 bar ... 100 bar: 2 x times
the range end value
Range 600 bar: 900 bar

Weight

1.2 kg

Material

Process connection: 316 L stainless steel * / Hastelloy C *
Diaphragm: Ceramic (Al₂O₃) - gold plated /
Hastelloy C /
Hastelloy C - gold plated

Fill fluid:

ranges ≥ 2.5 bar:
Silicone oil / carbon fluoride /
white oil (corresponds to re-
quirements of the US Food
and Drug Administration (FDA):
21CFR172.878 and
21CFR178.3620)

O-rings:

ranges ≤ 400 mbar:
Viton(FPM) / Perbunan(NBR)/
Chemraz 505 * (medium resistivity
comparable to PTFE)

Amplifier housing /

Housing cover:

aluminium with epoxy resin coat /
stainless steel

* in compliance with NACE MR0175 Class II

Process connection

Male thread / female thread 1/2-14 NPT or male thread acc. to DIN EN 837 - form B - G 1/2 (R 1/2" manometer) or male thread acc. to DIN EN 837 - form D - G 1/2 (R 1/2" manometer) for convex seal or frontbonded diaphragm (not for ranges 60 mbar and 400 mbar).

Electrical connections

Two female threads 1/2-14 NPT or M 20 x 1.5 or one plug Han 8 U.
Screw terminals for wire cross-sections up to 2.5 mm².

Power supply

Transmitters with 4...20mA output signal

Power supply: 10.5 ... 45 V DC (14 ... 45 V DC with backlit
indicator), inverse polarity protection;
observe the approvals for explosion-proof
transmitters.

Residual ripple: Max. permissible residual ripple of
supply voltage during the communication:
• 7 V_{ss} at 50Hz ≤ f ≤ 100Hz
• 1 V_{ss} at 100Hz < f ≤ 200Hz
• 0.2 V_{ss} at 200Hz < f ≤ 300Hz

Fieldbus units

Power supply: 10.2 ... 32 V DC, inverse polarity protection;
observe the approvals for explosion-proof
transmitters.

Pollution degree

2 according to EN 61 010-1 (ANSI / ISA 82.01)

Overvoltage category

II according to EN 61 010-1 (ANSI / ISA 82.01)

Certificates and Approvals

Observe mounting conditions according to EN 60079-10; 1996ff!

Transmitters of the type of protection "Intrinsically safe EEx ia" according to the directions 94 / 9 / EG (ATEX)

● Transmitter with 4...20 mA output signal

Marking (DIN EN 50 014): II 1/2 G EEx ia IIC T6
 EC-Type-Examination Certificate: ZELM 01 ATEX 0064
 Supply and signal circuit type of protection Intrinsic Safety
 EEx ib IIB / IIC resp. EEx ia IIB / IIC for connection to supply
 units with maximum values:

II 1/2 G EEx ia IIC T4 ... T6,
 for Temperature class T4:
 $U_i = 30 \text{ V}$
 $I_i = 200 \text{ mA}$
 $P_i = 0,8 \text{ W}$ for T4 with $T_a = (-40...+85)^\circ\text{C} / (-104...+185)^\circ\text{F}$
 $P_i = 1,0 \text{ W}$ for T4 with $T_a = (-40...+70)^\circ\text{C} / (-104...+158)^\circ\text{F}$

for Temperature class T5, T6:
 $U_i = 30 \text{ V}$
 $I_i = 25 \text{ mA}$
 $P_i = 0,5 \text{ W}$ for T6 with $T_a = (-40...+40)^\circ\text{C} / (-104...+104)^\circ\text{F}$
 $P_i = 0,75 \text{ W}$ for T5 with $T_a = (-40...+40)^\circ\text{C} / (-104...+104)^\circ\text{F}$

effective internal capacitance $C_i \leq 10 \text{ nF}$,
 effective internal inductivity $L_i \approx 0$

Permissible ambient temperature range in dependence on
 temperature class:

Temperature class	Ambient temperature minimum	Ambient temperature maximum
T4	-40 °C -104 °F	+85 °C +185 °F
T5	-40 °C -104 °F	+40 °C +104 °F
T6	-40 °C -104 °F	+40 °C +104 °F

● Field Bus transmitters (PROFIBUS / Foundation Fieldbus)
 Marking (DIN EN 50 014): II 1/2 G EEx ia IIB/IIC T6
 EC-Type-Examination Certificate: ZELM 01 ATEX 0063
 Supply and signal circuit type of protection Intrinsic Safety
 EEx ib IIB / IIC resp. EEx ia IIB / IIC for connection to FISCO
 supply units with rectangular or trapezoidal characteristics with
 maximum values:

II 1/2G EEx ia respectively ib IIC T4...T6 $U_i = 17.5 \text{ V}$
 $I_i = 360 \text{ mA}$
 $P_i = 2.52 \text{ W}$

II 1/2G EEx ia respectively ib IIB T4...T6 $U_i = 17.5 \text{ V}$
 $I_i = 380 \text{ mA}$
 $P_i = 5.32 \text{ W}$

resp. for connection to supply unit or barrier with linear characteristics maximum values:

II 1/2G EEx ia respectively ib IIC T4...T6 $U_i = 24 \text{ V}$
 $I_i = 250 \text{ mA}$
 $P_i = 1.2 \text{ W}$

effective internal inductance $L_i \leq 10 \mu\text{H}$,
 effective internal capacitance $C_i \approx 0$

Permissible ambient temperature range in dependence on
 temperature class:

Temperature class	Ambient temperature minimum	Ambient temperature maximum
T4	-40 °C -104 °F	+85 °C +185 °F
T5	-40 °C -104 °F	+40 °C +104 °F
T6	-40 °C -104 °F	+40 °C +104 °F

Transmitters of the type of protection "flameproof enclosure EEx d" according to the directions 94 / 9 / EG (ATEX)

Marking (DIN EN 50 014): II 1/2 G EEx d IIC T6
 EC-Type-Examination Certificate: PTB 00 ATEX 1018
 Ambient temperature range: -40 °C ... 75°C
 (-104°F ... 167°F)

Transmitters of category 3 for the application in "Zone 2" according to the directions 94 / 9 / EG (ATEX)

Marking (DIN EN 50 014): II 3 G EEx nL IIC T6
 EC-Type-Examination Certificate: ZELM 01 ATEX 3059
 Operating conditions:

Supply and signal circuit
 (terminals signal + / -): $U \leq 55 \text{ V}$
 $U \leq 22.5 \text{ mA}$

Ambient temperature range:
 Temperature class T4 $T_a = -40 \text{ °C} \dots 85 \text{ °C}$
 (-104°F ... 185°F)
 Temperature class T5, T6 $T_a = -40 \text{ °C} \dots 40 \text{ °C}$
 (-104°F ... 104°F)

Factory Mutual (FM) (pending)

Intrinsically safe,
 Explosion-Proof: Class I, Division 1, Groups A, B, C, D
 Class II/III, Division 1, Groups E, F, G
 Degree of protection: NEMA Type 4X (Indoor or outdoor)

Canadian Standard (CSA) (pending)

Intrinsically safe,
 Explosion-Proof: Class I, Division 1, Groups A, B, C, D
 Class II, Division 1, Groups E, F, G
 Class III
 Degree of protection: NEMA Type 4X (Indoor or outdoor)

11 Dimensional Diagrams

Transmitter with barrel-type amplifier housing
 Errors and omissions excepted. All dimensions in millimeters.

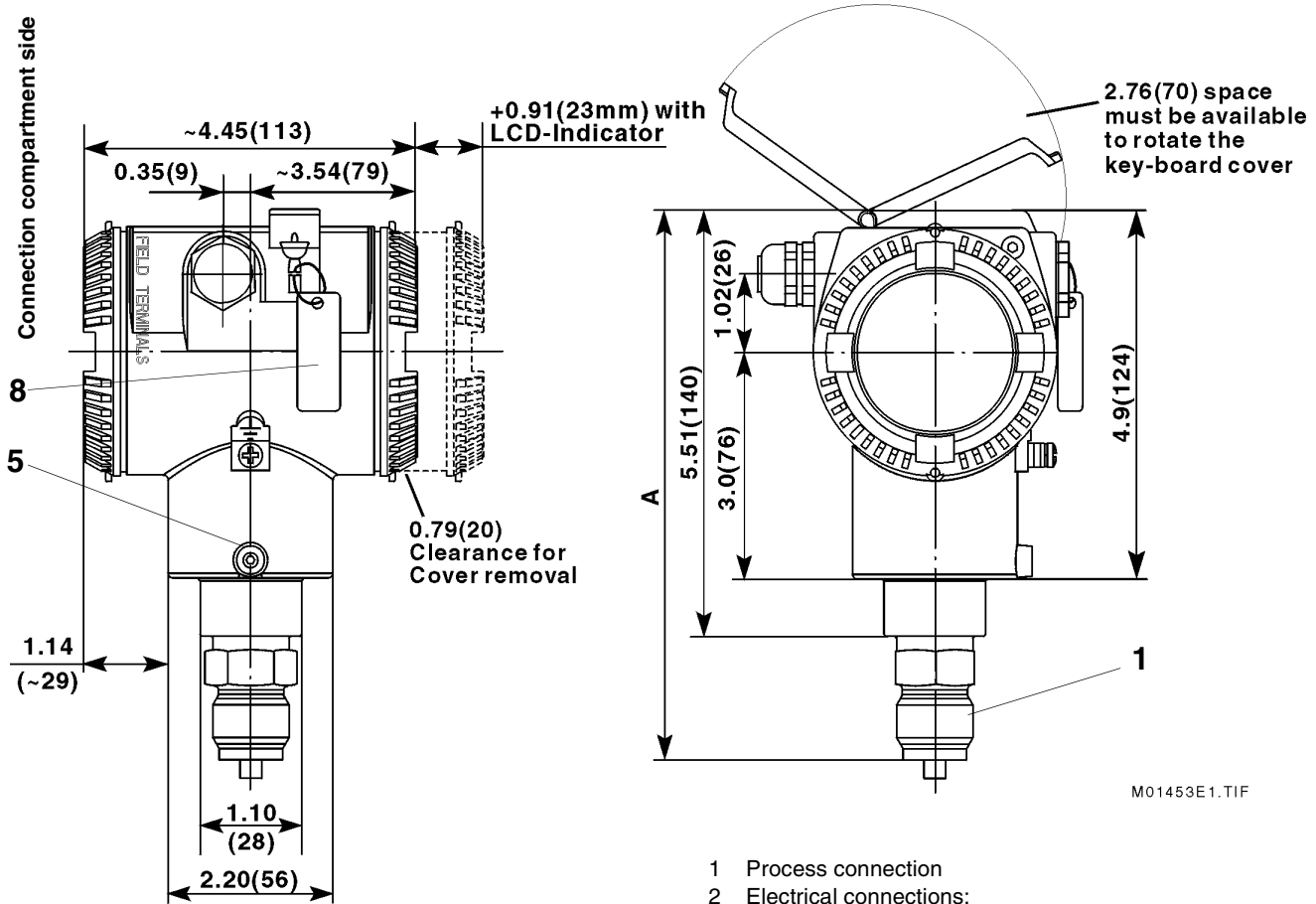

M01453E1.TIF

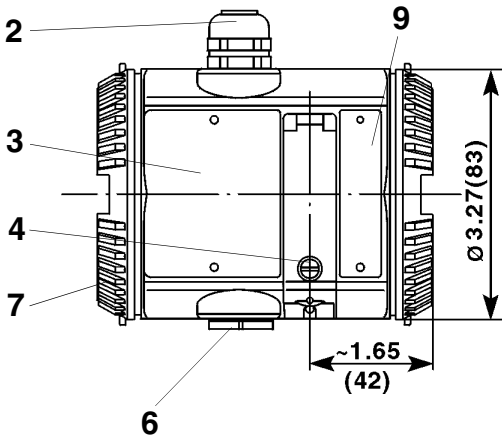

- 1 Process connection
- 2 Electrical connections:
M20x1.5 cable gland on both sides or
1/2-14 NPT female thread or one plug Han 8U
- 3 Type plate
- 4 Captive screw for key unit cover
- 5 Housing rotation stop screw
- 6 Blind plug
- 7 Enclosure cover
- 8 Tie-on plate, e.g. for tag number (optional)
- 9 Plate, also with key legend

Dimension "A" is dependent upon range and process connection:

Process connection	Ranges: 60mbar, 400mbar	Ranges: ≥ 2.5 bar
1/2-14NPT male thread	168	173
1/2-14NPT female thread	158	169, range 600 bar: 172
Spigot DIN 16288 Form B	167	173
Spigot DIN 16288 Form D for convex seal	178	183
Front-bonded diaphragm	----	dimen. see page 18
For ball valve connection	----	dimen. see page 18

Transmitter with DIN-type amplifier housing

Errors and omissions excepted. All dimensions in millimeters.

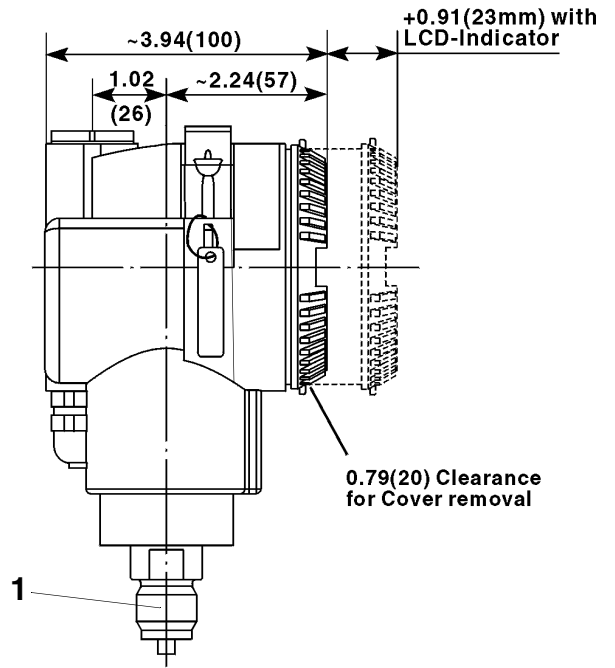
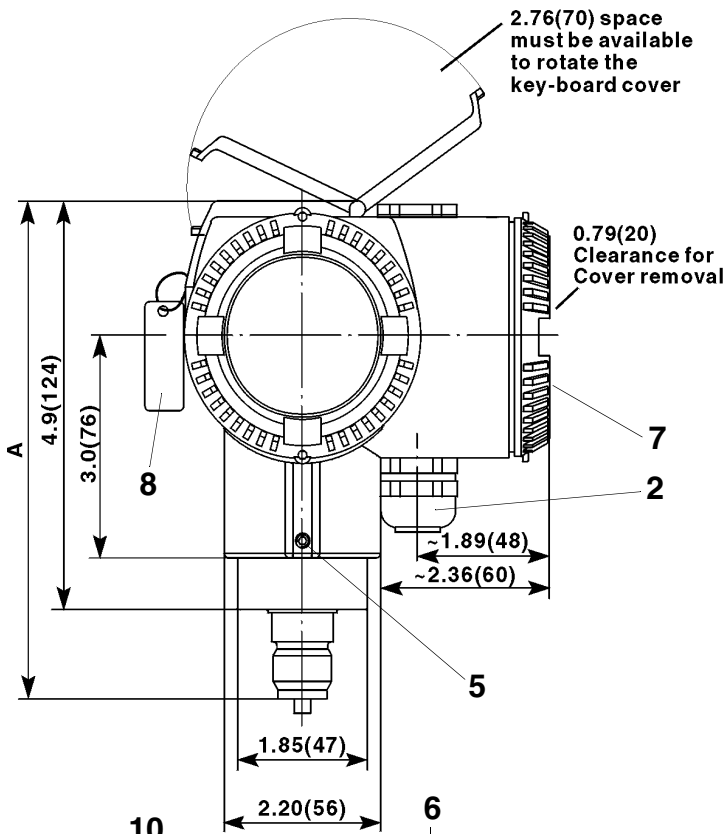

M01454E1.TIF

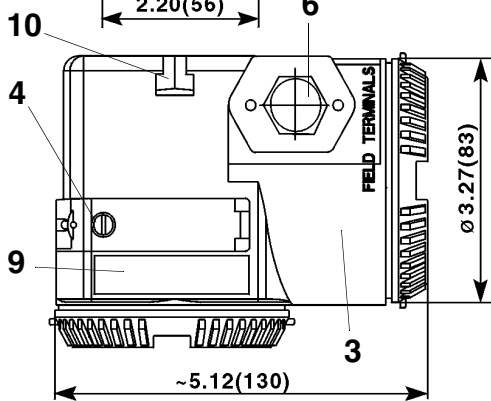

Connection compartment side

- 1 Process connection
- 2 Electrical connections:
M20x1.5 cable gland on both sides or
1/2-14 NPT female thread or one plug Han 8U
- 3 Type plate
- 4 Captive screw for key unit cover
- 5 Housing rotation stop screw
- 6 Blind plug
- 7 Enclosure cover
- 8 Tie-on plate, e.g. for tag number (optional)
- 9 Plate, also with key legend
- 10 Groove for screws when mounting on wall or pipe.

Dimension "A" is dependent upon range and process connection:

Process connection	Ranges: 60mbar, 400mbar	Ranges: ≥ 2.5 bar
1/2-14NPT male thread	168	173
1/2-14NPT female thread	158	169, range 600 bar: 172
Spigot DIN 16288 Form B	167	173
Spigot DIN 16288 Form D for convex seal	178	183
Front-bonded diaphragm	----	dimen. see page 18
For ball valve connection	----	dimen. see page 18

2020TG for "front-bonded diaphragm" (e.g. barrel-type)

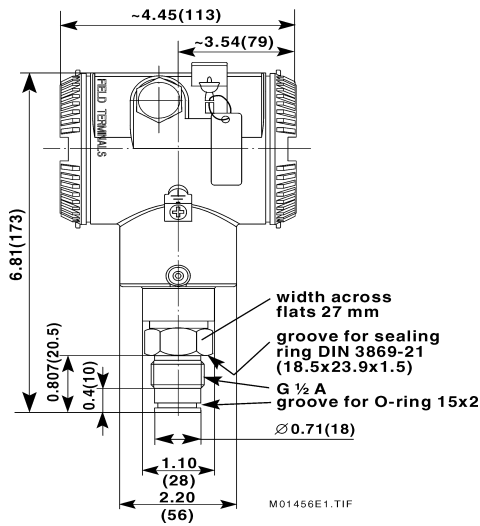

2020TG for „ball valve connection“ (e.g. barrel-type)

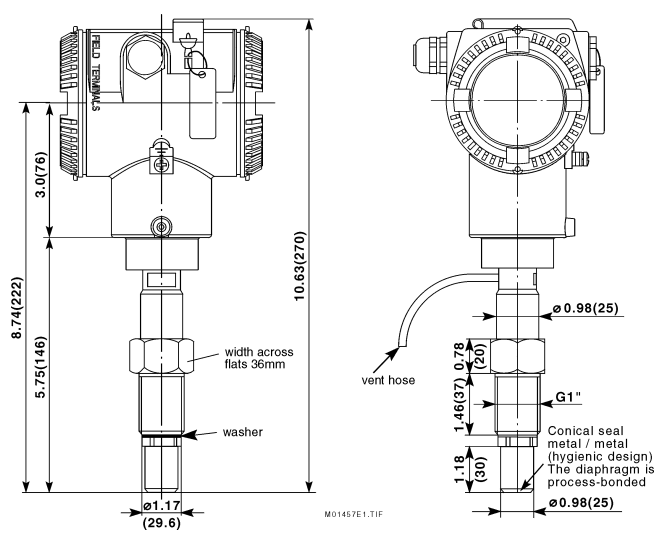

Pipe mounting

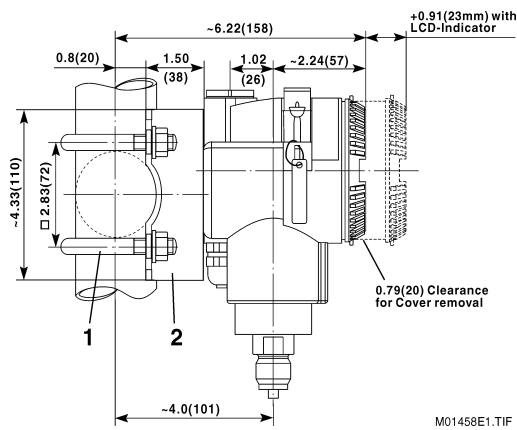

Wall mounting

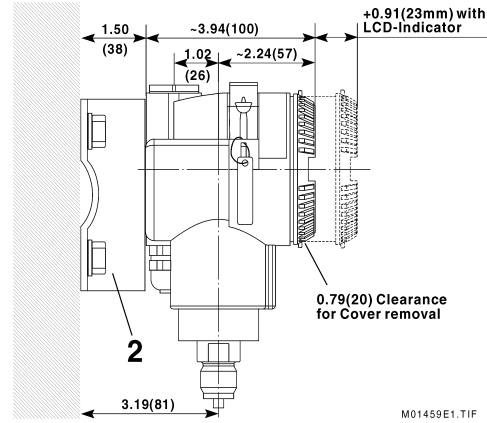

Pipe mounting

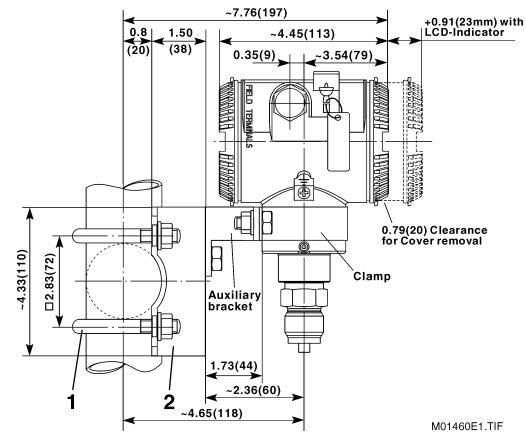

Wall mounting

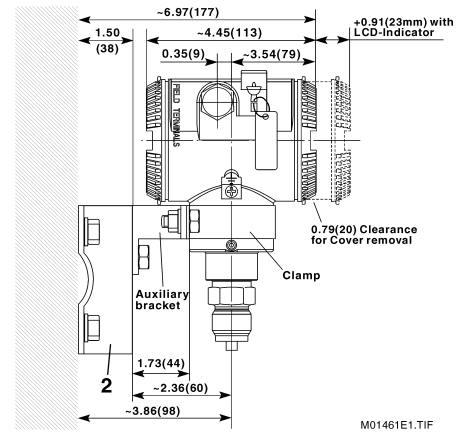

1 U-bolts for pipe mounting. Pipe: 2" (Internal-Ø). Rearrange the brackets for horizontal pipe mounting.

2 Brackets, hole-Ø: 11mm.



EG-KONFORMITÄTSERKLÄRUNG
EC DECLARATION OF CONFORMITY
ATTESTATION DE CONFORMITE C.E.

Hersteller: ABB Automation Products GmbH
Manufacturer / Fabricant: Minden

Anschrift: Schillerstraße 72
Address / Adresse: D-32425 Minden

Produktbezeichnung: Messumformer Multi Vision – 2010TA, 2010TC, 2010TD, 2020TA, 2020TG
Product name: Transmitter Multi Vision – 2010TA, 2010TC, 2010TD, 2020TA, 2020TG
Désignation du produit: Transmetteur Multi Vision – 2010TA, 2010TC, 2010TD, 2020TA, 2020TG

Das Produkt stimmt mit den Vorschriften folgender Europäischer Richtlinien überein:

*This product meets the requirements of the following European directives:
 Les produits répondent aux exigences des Directives C.E. suivantes:*

89/336/EEC 89/336/EEC 89/336/C.E.E.	EMV-Richtlinie * <i>Electromagnetic Compatibility Directive *</i> <i>Directives concernant la compatibilité électromagnétique *</i>
73/23/EEC 73/23/EEC 73/23/C.E.E.	Niederspannungsrichtlinie * <i>EC-Low-Voltage Directive *</i> <i>Directives concernant la basse tension *</i>
97/23/EEC 97/23/EEC 89/336/C.E.E.	Druckgeräterichtlinie <i>Pressure Instruments Directive</i> <i>Directives concernant les appareils soumis à pression</i>

Für Geräte in Ex-Ausführung gemäß Kennzeichnung auf Typschild gilt zusätzlich:
*For products in Ex design according to identification on nameplate the following is additionally applicable:
 Pour des produits en exécution Ex selon marque sur plaque signalétique le suivant est aussi applicable:*



94/9/EEC 94/9/EEC 94/9/C.E.E.	ATEX-Richtlinie <i>ATEX Directive</i> <i>ATEX Directive</i>
--	--

*** einschließlich Änderungen und deutscher Umsetzung durch das EMVG und Gerätesicherheitsgesetz**
** including alterations and German realization by the EMC law and the instruments safety law*
** y compris les modifications et la réalisation allemande par la loi concernant la compatibilité électromagnétique et la sécurité d'appareils*

Die Übereinstimmung mit den Vorschriften dieser Richtlinien wird nachgewiesen durch die vollständige Einhaltung folgender Normen:

*Conformity with the requirements of these Directives is proven by complete adherence to the following standards:
 La conformité avec les exigences de ces directives est prouvée par l'observation complète des normes suivantes:*

EN 50 081-1 / EN 50 082-2 / EN 61 010-1
Ex: EN 50 014 / EN 50 284 / EN 50 018 / EN 50 020

20.11.2000

Datum
Date
Date

Dieter Friedemann
Standortleitung
Division manager
Responsable de la division

Friedrich Kipp
Qualitätsmanagement
Quality management
Assurance de la qualité

ABB Automation Products

Postal address:
Schillerstr. 72
D-32425 Minden
Visitor address:
Schillerstr. 72
D-32425 Minden

Telephone:
+49(0)571 830-0
Telefax:
+49(0)571 830 1846
<http://www.abb.de/automation>
UST-IdNr.: DE 115 300 097

Head Office:
Eschborn
Registry Court:
Amtsgericht Frankfurt/Main
Commercial Register:
HRB 49651

Chairman of the Supervisory Board:
Bengt Pihl
Managing Directors:
Uwe Alwardt (Chairman)
Burkhard Block
Erik Huggare

Commerzbank AG Frankfurt
Account: 589 635 200
Sorting Code: 500 400 00

F 6016 AL



Prüf- und Zertifizierungsstelle

ZELM Ex



(1) **EC-TYPE-EXAMINATION CERTIFICATE**
(Translation)

(2) Equipment and Protective Systems Intended for Use in
Potentially Explosive Atmospheres - **Directive 94/9/EC**

(3) EC-TYPE-EXAMINATION CERTIFICATE Number:

ZELM 01 ATEX 0064

(4) Equipment: **Pressure and Differential Pressure - Transducer
type 20.0T. HART**

(5) Manufacturer: **ABB Automation Products GmbH**

(6) Address: **Schillerstrasse 72, D-32425 Minden**

(7) This equipment and any acceptable variation thereto are specified in the schedule to this certificate and the documents therein referred to.

(8) The Prüf- und Zertifizierungsstelle ZELM Ex, notified body No. 0820 in accordance with Article 9 of the Council Directive 94/9/EC of 23 March 1994, certifies that this equipment has been found to comply with the Essential Health and Safety Requirements relating to the design and construction of equipment and protective systems intended for use in potentially explosive atmospheres, given in Annex II to the Directive.

The examination and test results are recorded in the confidential report ZELM Ex 0200112086.

(9) Compliance with the Essential Health and Safety Requirements has been assured by compliance with:

EN 50 014: 1997+A1+A2

EN 50 020: 1994

EN 50 284: 1999

(10) If the sign "X" is placed after the certificate number, it indicates that the equipment is subject to special conditions for safe use specified in the schedule to this certificate.

(11) This EC-type-examination Certificate relates only to the design and construction of the specified equipment in accordance with Directive 94/9/EC. Further requirements of this Directive apply to the manufacture and supply of this equipment.

(12) The marking of the equipment shall include the following:



II 1/2 G EEx ia IIC T6

Zertifizierungsstelle ZELM Ex

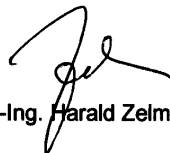
Dipl.-Ing. Harald Zelm



Braunschweig, June 28, 2001

Sheet 1/4

EC-type-examination Certificates without signature and stamp are not valid. The certificates may only be circulated without alteration. Extracts or alterations are subject to approval by the Prüf- und Zertifizierungsstelle ZELM Ex. In the case of dispute, the German text shall prevail.

Prüf- und Zertifizierungsstelle ZELM Ex • Siekgraben 56 • D-38124 Braunschweig



(13) **SCHEDULE**

(14) **EC-TYPE-EXAMINATION CERTIFICATE ZELM 01 ATEX 0064**

(15) Description of equipment

The Pressure, Differential Pressure Transducer is intended for use for conversion of physical quantities like pressure, differential pressure and temperature into an analogous electrical standard signal of a 4 ... 20 mA current loop inside the hazardous area.

The Pressure, Differential Pressure Transducer is mounted into a housing meeting the degree of protection IP ≥ 65 according to EN 60529:1991.

The Pressure, Differential Pressure Transducer is allowed to be installed into the partition between the hazardous areas of category 1G and category 2G.

The operating conditions for service with flammable measuring mixtures – which are non-explosive - and higher pressures are to be taken from the instruction manual and operation manual respectively.

The attached pressure works on the ceramic measuring sensor or the silicon measuring sensor.

Maximum permissible ambient temperatures depending on the temperature class are shown in the following table:

Temperature class	lower limit of ambient temperature	upper limit of ambient temperature
T 4	-40 °C	+85 °C
T 5	-40 °C	+40 °C
T 6	-40 °C	+40 °C

Type of protection: Pressure and Differential Pressure Transducer type 20.0T. HART **II 1/2 G EEx ia IIC T6**

For mounting at category 1G:

Transducer with measuring elements without or with pressure sensor **II 1/2 G EEx ia IIC T6 resp. EEx ib IIC T6**

Having the capacitive measuring element type 2020T. (HART) (≤ 400 mbar) and a supply with an intrinsically safe circuit EEx ib IIB/IIC the use is permitted for category 2G only.

Sheet 2/4

EC-type-examination Certificates without signature and stamp are not valid. The certificates may only be circulated without alteration. Extracts or alterations are subject to approval by the Prüf- und Zertifizierungsstelle ZELM Ex. In the case of dispute, the German text shall prevail.

Prüf- und Zertifizierungsstelle ZELM Ex • Siekgraben 56 • D-38124 Braunschweig



Prüf- und Zertifizierungsstelle

ZELM Ex



Schedule to EC-TYPE-EXAMINATION CERTIFICATE_ZELM 01 ATEX 0064

Electrical data

Supply and signal circuit (terminals signal +,-) type of protection Intrinsic Safety EEx ib IIB/IIC resp. EEx ia IIB/IIC for connection to supply units with maximum values:

II 1/2G EEx ia resp. ib IIC T4...T6
for temperature class T4

$U_i = 30 \text{ V}$
 $I_i = 200 \text{ mA}$
 $P_i = 0,8 \text{ W}$ for T4 and $T_a = (-40...+85)^\circ\text{C}$
 $P_i = 1,0 \text{ W}$ for T4 and $T_a = (-40...+70)^\circ\text{C}$

for temperature class T5, T6

$U_i = 30 \text{ V}$
 $I_i = 25 \text{ mA}$
 $P_i = 0,5 \text{ W}$ for T6 and $T_a = (-40...+40)^\circ\text{C}$
 $P_i = 0,75 \text{ W}$ for T5 and $T_a = (-40...+40)^\circ\text{C}$

effective internal capacitance $C_i \leq 10 \text{ nF}$
effective internal inductance is negligibly small

Temperature sensor circuit: (supply terminals 12, 14) (signal terminals 11, 13) type of protection Intrinsic Safety EEx ia IIC bzw. EEx ib IIC for connection to passive intrinsically safe sensors only maximum values:

$U_o = 10,6 \text{ V}$
 $I_o = 1,5 \text{ mA}$
 $P_o = 4 \text{ mW}$
 $C_o = 2,3 \text{ }\mu\text{F}$
 $L_o = 1 \text{ H}$

References:

The instruction manual / operation manual has to be considered.

Having the capacitive measuring element type 2020T. HART ($\leq 400 \text{ mbar}$) and a supply with an intrinsically safe circuit EEx ib IIB/IIC the use is permitted for category 2G only.

Sheet 3/4

EC-type-examination Certificates without signature and stamp are not valid. The certificates may only be circulated without alteration. Extracts or alterations are subject to approval by the Prüf- und Zertifizierungsstelle ZELM Ex. In the case of dispute, the German text shall prevail.

Prüf- und Zertifizierungsstelle ZELM Ex • Siekgraben 56 • D-38124 Braunschweig



Prüf- und Zertifizierungsstelle

ZELM Ex



Schedule to EC-TYPE-EXAMINATION CERTIFICATE_ZELM 01 ATEX 0064

- (16) Report No.
ZELM Ex 0200112086
- (17) Special conditions for safe use
not applicable
- (18) Essential Health and Safety Requirements
met by standards

Zertifizierungsstelle ZELM Ex

Braunschweig, June 28, 2001

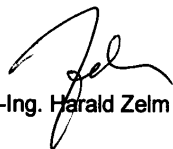
Dipl.-Ing. Harald Zelm



Sheet 4/4

EC-type-examination Certificates without signature and stamp are not valid. The certificates may only be circulated without alteration. Extracts or alterations are subject to approval by the Prüf- und Zertifizierungsstelle ZELM Ex. In the case of dispute, the German text shall prevail.

Prüf- und Zertifizierungsstelle ZELM Ex • Siekgraben 56 • D-38124 Braunschweig

This Technical Documentation is subject to copyright. Translation, reproduction and distribution in any form – even as a revised version or in extracts – are forbidden without prior permission of the holder of rights; particularly reprint, photomechanical or electronic reproduction and storage in data processing systems or data networks are not allowed. Offenders will be prosecuted and civil action brought against them.



ABB Automation Products GmbH
Hartmann & Braun
Schillerstraße 72
D-32425 Minden
Tel. +49(0)571 830-0
Fax +49(0)571 830-1846
<http://www.abb.com>

Technical revision reserved
Printed in the Fed. Rep. of Germany
42/15-753-7 EN 08.2001