

Table of contents

	Page
Remarks	2
Installation and commissioning	
1. Identifying the instrument	3
2. Selecting installation site and mounting the instrument	3
3. Connecting signals	4
4. Connecting the power supply	4
5. Commissioning the instrument	4
Operation	
Front panel	5
Display	5
Parameter definition	6
Parameter-definition principle	6
Complete parameter-definition	8
Selftune	
Automatic selftune	12
Manual adjusting of a PID controller	12
Ramps and alarms	
Ramps	13
Alarms	13
Example	13
Option: Retransmission of process variables	4
Calibration	14
Error messages	15
Maintenance	15
Conversion	16
Appendix	
Application	17
Description	17
Technical data	18
Packaging for transport or for return to manufacturer	19

Important instructions for your safety! Please read and observe!

Correct and safe operation of the controller calls for appropriate transportation and storage, expert installation and commissioning as well as correct operation and meticulous maintenance.

Only those persons conversant with the installation, commissioning, operation and maintenance of similar apparatuses and who possess the necessary qualifications are allowed to work on the controller.

Please take note of

- the contents of this Operating Manual,
- the safety regulations affixed to the controller and
- the safety regulations pertaining to the installation and operation of electrical systems.

The directives, norms and guidelines mentioned in this Operating Manual are applicable in the Federal Republic of Germany. When using the controller in other countries, please observe the national regulations prevailing in the respective country.

The controller has been designed and tested in accordance with DIN VDE 0411 Part 1 „Safety requirements for electronic measuring apparatuses“, and has been supplied in a safe condition. In order to retain this condition and to ensure safe operation, the safety instructions in this Operating Manual bearing the headline „Caution“ must be observed. Otherwise, persons can be endangered and the controller itself, as well as other equipment and facilities can be damaged.

If the information in this Operating Manual should prove to be insufficient in any point, the Service Department will be delighted to give you more information.

Remarks on symbols

☐, [AT], ▲, ▼ means that the respective key on the controller front panel should be pressed.

Installation and commissioning

1. Identifying the instrument

The unit is identified by its rating plate. The rating plate is located on the side of the case. It contains the following information:

- voltage range of the built-in power supply unit
- type of sensor input for which the controller has been adapted to at the factory: thermocouple ("T/C"), Pt100 resistance thermometer ("RTD") or mA input
- type and quantity of outputs: 1 or 2 0/4...20 mA or relay outputs
- Alarm outputs (always available)
- optional retransmission of process variables ("0/4...20 mA")

2. Selecting the installation site and mounting the unit

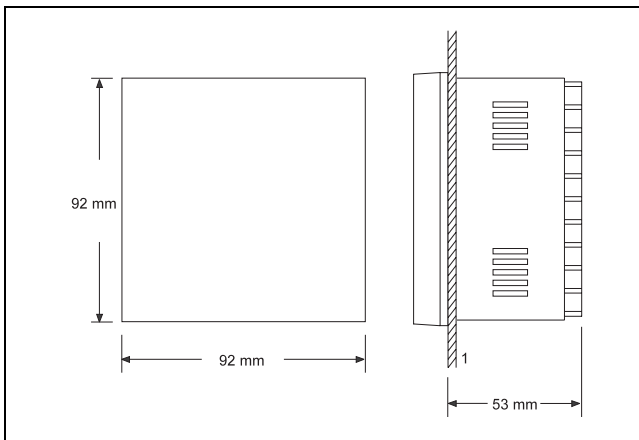

Fig. 1 Dimensional diagram
Z-18790 left Panel cutout
right Depth behind panel
1 Panel

⚠ Caution

To maintain protection against shocks, the device may only be operated when fully installed.

The controller is designed for front-panel mounting in machines, devices, control cabinets and control rooms. The installation site should be selected in such way that relevant environmental and mechanical capability requirements are fulfilled (see "Technical Data").

3. Connecting the signals

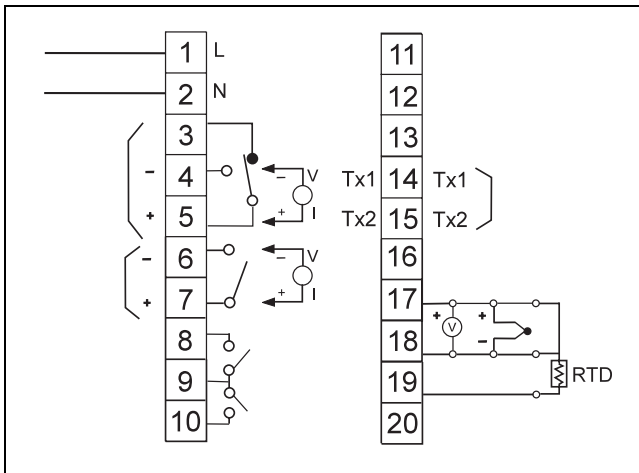

Fig. 2 Wiring diagram
Z-18791

1, 2	Power supply
3, 4, 5	Control output 1
6, 7	Control output 2
8	Alarm 1
9	Alarm Com.
10	Alarm 2
14, 15	Retransmission of process variables
17, 18	
19	Sensor input (RTD, TC, mA)

⚠ Caution

When selecting the lead material as well as when installing and connecting the power leads, the local specifications for installation of power current systems are to be observed.

The controller is ex works either equipped with a measuring input for thermocouple, Pt100-resistance thermometer or for mA uniform signals.

The type of thermocouple or Pt100 can be modified per software.

Changing the measuring input between the thermocouple, Pt100 and mA is however not possible without changing the hardware ("Conversion").

- Connect sensors, control and alarm outputs in accordance with fig. 2.

4. Connecting the power supply

(see fig. 2)

⚠ Caution

When selecting the lead material as well as when installing and connecting the power leads, the local specifications for installation of power current systems are to be observed.

Note

The controllers are fully insulated according to protection class category II. There is no grounding conductor to connect.

1. Install an external mains isolator, which completely disconnects all power.
2. Connect the power supply as illustrated in fig. 2.

5. Commissioning the instrument

⚠ Caution

Before switching on the instrument, make sure that the adjusted operating voltage corresponds to the mains voltage.

- Switch on the instrument using the external mains isolator.

After switch-on, the identification of the microprocessor and the software version are first displayed. Then follows an activation of all segments of LED displays, including the status LEDs for outputs and alarms in self-test.

Operation

Front panel

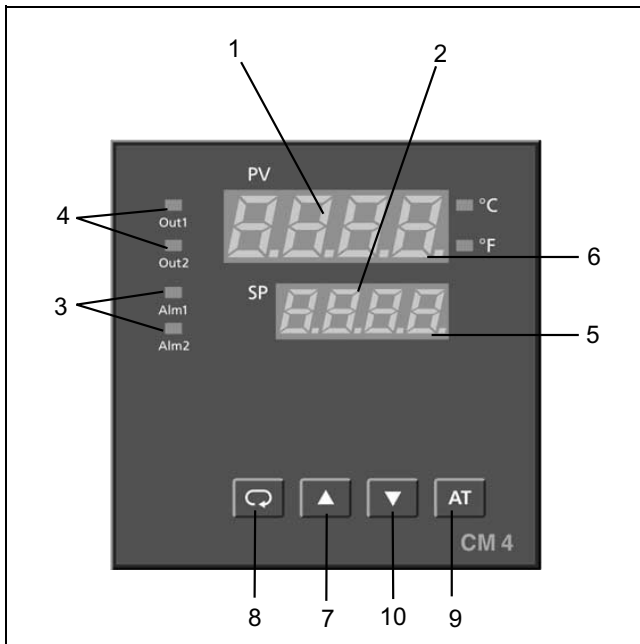

Fig. 3 Front panel

Z-18893	1	Process variable
	2	Setpoint
	3	Status LED for alarm relay
	4	Status LED for output relay
	5	Status display „manual mode“
	6	Status display „selftune active“
	7	Key „increase“
	8	Key „menü“
	9	Key „start selftune“ or „back to main operator level“
	10	Key „decrease“

Key

Key	Function description
	switches to the next parameter within a menu level.
	if pressed for at least 6 s, switches to the next menu level (only possible if the last parameter of the previous menu is indicated).
	increases the parameter value.
	decreases the parameter value.
	returns to the standard mode (exits a submenu, aborts selftune and returns from "Manual" to "Automatic").
	if pressed for at least 6 s, starts selftune.
+	switches the lower display from setpoint to percentage value of output 1; repeated pressing brings output 2 - if existing - onto display.
+	if pressed for at least 6 s, switches over to manual operation mode.

Display

In the standard mode, the process variable is indicated in the upper display. In the lower display the setpoint, or after pressing + the percentage value of the output is indicated.

The setpoint can be adjusted with and .

When scrolling through the menu levels, in the upper display a short text describing the parameter appears, whose value is shown in the lower display and which can be modified with and .

The status LEDs for the outputs and alarms light up respectively anytime the relays are switched on.

The manual operation is shown in the lower display by an illuminated point in the lower right corner.

Parameter definition

Parameter-definition principle

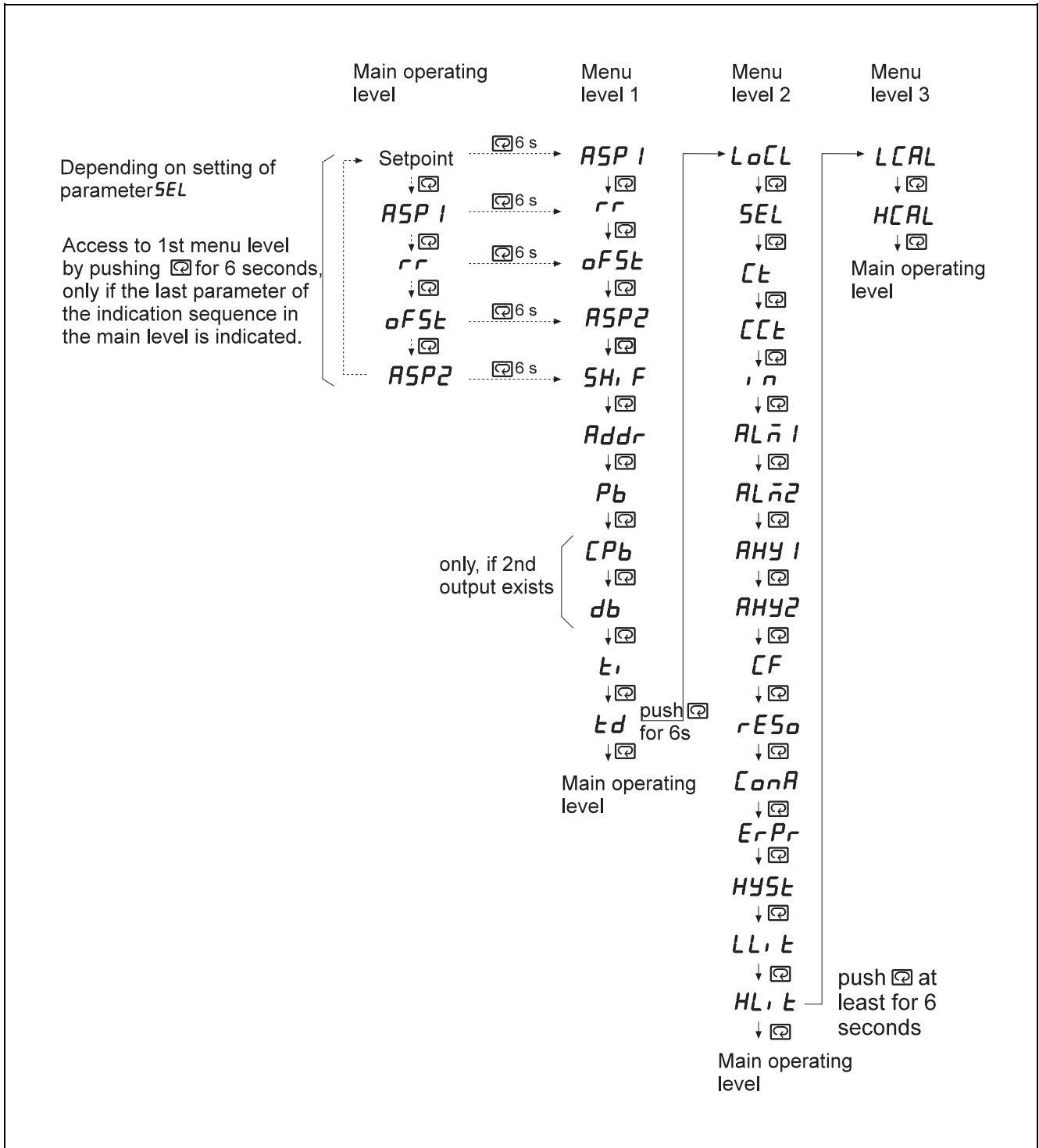





Fig. 4 Flow diagram
Z-18891

1. Display the first parameter accessible at the main operator level:



Remarks

At the main operator level, only those parameters are accessible, which were defined in parameter *SEL* (see page 9). The factory setting for *SEL* is 0, i.e. no additional parameters can be selected at the main operator level.

If parameter *LoLL* has the value 1, parameters can only be displayed but can not be changed (see page 9).



2. Change parameter:
, 

3. Display the next parameter:

4. Change the parameter:
, 

etc. until

5. Last parameter is displayed:



6. Change parameter:
, 

7. Access the first menu level:
 for at least 6 s

8. Change parameter:
, 



9. Display the next parameter:

etc. up to the last parameter of the first menu level *Ed*.



10. Either return to the main operator level:

or
proceed further to the second menu level:
 for at least 6 s

11. Change parameter:
, 

12. Display the next parameter:

13. Change parameter:
, 

etc. up to the last parameter of the second menu level *HL, E*.

14. Either return to the main operator level:

or
proceed further to the third menu level:
 for at least 6 s

15. Calibrate controller: see section on "Calibration"
or
return to the main operator level:

Remarks



























The complete parameter-definition, the parameters and their adjustment possibilities as well as their factory settings are listed on pages 8 to 11.

With  it is possible to return to the main operator level at any time.

Modified parameters become immediately effective.

Complete parameter-definition

In order to parameter-define the controller completely, the steps provided below must be processed consecutively.

Key	Display	Parameter	Parameter values <u>underlined</u> or FS = Factory Setting	change
Main operator level				
 for at least 6 s	<i>ASP 1</i>	defines the alarm setpoint value for the first alarm configured under <i>ALn 1</i> . Depending on the type of alarm defined for the parameter <i>ALn 1</i> , this can be either an absolute alarm value or a deviation alarm value (see also Section on "Alarms").	<ul style="list-style-type: none"> absolute alarm value in the range <i>LL, E...HL, E</i>, if <i>ALn 1</i> = 0, 1, 4, 5 relative alarm value in the range <i>LL, E...HL, E</i>, if <i>ALn 1</i> = 2, 3, 6, 7, 8, 9, 10, 11 time value in the range 0... 3600 min, if <i>ALn 1</i> = 12 or 13 FS 200 °C	 , 
	<i>rr</i>	defines the setpoint ramp rate to allow the process to reach the new setpoint via a linear ramp after setpoint change.	<ul style="list-style-type: none"> <u>0</u>...200 °C/min (360 °F/min), if <i>rn</i> = 0 to 9 0...3600 digit/min, if <i>rn</i> = 10 	 , 
	<i>oF5t</i>	defines the offset value for manual reset (= operating point), if <i>t1</i> = 0, i.e. the output signal of the controller is shifted by <i>oF5t</i> .	<u>0.0</u> ...100 %	 , 
<p>Notice This parameter is only required when the controller does not use any integral component (integral action time <i>t1</i>).</p>				
	<i>ASP2</i>	defines the alarm setpoint value for the second alarm configured under <i>ALn 2</i> . Depending on the type of alarm defined for parameter <i>ALn 2</i> , this can either be an absolute alarm value or a deviation alarm value (see also section on "Alarms").	<ul style="list-style-type: none"> absolute alarm value in the range <i>LL, E...HL, E</i>, if <i>ALn 1</i> = 0, 1, 4, 5 relative alarm value in the range <i>LL, E...HL, E</i>, if <i>ALn 1</i> = 2, 3, 6, 7, 8, 9, 10, 11 FS 200 °C	 , 
	<i>SH, F</i>	defines the offset shift for the process variable in the display (measured value correction).	-111... <u>0</u> ...+111 °C	 , 
<p>Example The display shows 1 °C less than the actual temperature. This can be corrected with an input of +1 °C.</p>				
	<i>Addr</i>	defines the type of the output (see section "Option: retransmission of process variables")		 , 
	<i>Pb</i>	defines the proportional range of output 1 (heating)	0... <u>10</u> ...200 °C (0 for ON/OFF control)	 , 
<p>Notice Changing this parameter has decisive effects on the control action.</p>				
	<i>CPb</i>	defines the proportional range of output 2 (= cooling) (if available)	0.0... <u>1.0</u> ...4.0 (× <i>Pb</i>)	 , 
	<i>db</i>	defines the dead zone (= off) between heating and cooling (if a second output exists)	-100... <u>+5</u> ...+100 % (of <i>Pb</i>)	 , 

Key	Display	Parameter	Parameter values <u>underlined</u> or FS = Factory Setting	change
	<i>t_i</i>	defines integral (reset) time. This action component prevents stationary control deviations. Notice Changing this parameter has decisive effects on the control action. A big integral action time in a slow control, whereas a too small value can lead to overshooting and even to a destabilisation of the entire control process.	0... <u>120</u> ...3600 s	
	<i>t_d</i>	defines the derivative (rate) time for the differential component. This component enables quicker reaction to changes in the stationary status. Notice A modification of this parameter has decisive effects on the control action. A too small derivative time initially produces drastic overshooting, whereas a too big value produces oscillations and even destabilisation of the entire control process.	0... <u>30</u> ...1000 s	
	PV	back to the main operator level or to 1. menu level		
 for at least 6 s	<i>LoLL</i>	determines if the keys are disabled for making modifications on parameter values Notice The keyboard is disabled with immediate effect!	0 activated <u>1</u> <u>deactivated</u>	
	<i>SEL</i>	defines the parameters which can be directly accessed on the main operator level	<ul style="list-style-type: none"> 0 <u>no parameter</u> 1 <u>ASP 1</u> 2 <u>rr</u> 3 <u>oFSt</u> 4 <u>ASP 1, rr</u> 5 <u>ASP 1, oFSt</u> 6 <u>rr, oFSt</u> 7 <u>ASP 1, rr, oFSt</u> 8 <u>ASP2</u> 9 <u>ASP 1, ASP2</u> 10 <u>ASP2, rr</u> 11 <u>ASP2, oFSt</u> 12 <u>ASP 1, rr, ASP2</u> 13 <u>ASP 1, oFSt, ASP2</u> 14 <u>rr, oFSt, ASP2</u> 15 <u>ASP 1, rr, oFSt, ASP2</u> 	
	<i>Lt</i>	defines the proportional cycle time for relay output 1 Example Cycle time duration 10 s and calculated output signal 40 %: Output relay closes for 4 s and opens afterwards for 6 s	0...120 s FS relay: 20 s analog: 0 s	
	<i>Lt</i>	defines the proportional cycle time for relay output 2 (if available) Example see above	0...120 s FS relay: 20 s analog: 0 s	

Key	Display	Parameter	Parameter values <u>underlined</u> or FS = Factory Setting	change
	<i>IN</i>	<p>defines the type of sensor</p> <p>Remarks</p> <p>Modification of the signal type (TC, Pt100, linear) requires a hardware change (see Section on "Conversion")!</p> <p>When modifying the measuring sensor, the parameters <i>LL₁</i> and <i>HL₁</i> for the measuring range must be matched accordingly.</p>	0 thermocouple type J 1 thermocouple type K 2 thermocouple type T 3 thermocouple type E 4 thermocouple type B 5 thermocouple type R 6 thermocouple type S 7 thermocouple type N 8 Pt100 (DIN 43 760) 9 Pt100 (JIS C1604-1981) 10 linear (-10...60 mV, 0/4...20 mA)	
	<i>ALn 1</i>	<p>defines the alarm mode of alarm 1 (see also section on "Alarms")</p>	0 <u>overshooting of the alarm value <i>RSP 1</i></u> 1 <u>undershooting of alarm value <i>RSP 1</i></u> 2 <u>overshooting of SP + <i>RSP 1</i></u> 3 <u>undershooting of - <i>RSP 1</i></u> 4 like 0, however with suppression of the initial alarm 5 like 1, however with suppression of the initial alarm 6 like 2, however with suppression of the initial alarm 7 like 3, however with suppression of the initial alarm 8 leaving range SP +/- <i>RSP 1</i> 9 entering range SP +/- <i>RSP 1</i> 10 like 8, however with suppression of the initial alarm 11 like 9, however with suppression of the initial alarm 12 alarm relay OFF, when timer expires 13 alarm ON, when timer expires	
	<i>ALn 2</i>	<p>defines the alarm mode of alarm 2 (see also section on "Alarms")</p>	0 <u>overshooting of the alarm value <i>RSP 2</i></u> 1 <u>undershooting of alarm value <i>RSP 2</i></u> 2 <u>overshooting of SP + <i>RSP 2</i></u> 3 <u>undershooting of - <i>RSP 2</i></u> 4 like 0, however with suppression of the initial alarm 5 like 1, however with suppression of the initial alarm 6 like 2, however with suppression of the initial alarm 7 like 3, however with suppression of the initial alarm 8 leaving range SP +/- <i>RSP 2</i> 9 entering range SP +/- <i>RSP 2</i> 10 like 8, however with suppression of the initial alarm 11 like 9, however with suppression of the initial alarm	
	<i>AHY 1</i>	<p>defines the hysteresis of alarm 1 (see also Section on "Alarms")</p>	0... <u>0.5</u> ...20% of the range	
	<i>AHY 2</i>	<p>defines the hysteresis of alarm 2 (see also Section on "Alarms")</p>	0... <u>0.5</u> ...20% of the range	
	<i>CF</i>	<p>defines the dimension</p> <p>Notice</p> <p>The controller subsequently converts all values accordingly.</p>	0 °F 1 °C	

Key	Display	Parameter	Parameter values <u>underlined</u> or FS = Factory Setting	change																																																																																																																									
☞	<i>rESo</i>	defines the number of decimal points	0 <u>No decimal places</u> 1 <u>One decimal place</u> 2 Two decimal places (only when <i>i n</i> = 10) 3 Three decimal places (only when <i>i n</i> = 10)	▲, ▼																																																																																																																									
☞	<i>ConA</i>	defines the control action for output 1 (Output 2 (if available) always directly)	0 direct (cool) 1 <u>inverse (heat)</u>	▲, ▼																																																																																																																									
☞	<i>ErPr</i>	defines the reaction in case of sensor break	Controller with two control outputs: <table border="0"> <thead> <tr> <th></th> <th>Outp. 1</th> <th>Outp. 2</th> <th>Alarm 1</th> <th>Alarm 2</th> </tr> </thead> <tbody> <tr><td>0</td><td>Off</td><td>Off</td><td>Off</td><td>Off</td></tr> <tr><td>1</td><td><u>Off</u></td><td><u>Off</u></td><td><u>On</u></td><td><u>Off</u></td></tr> <tr><td>2</td><td><u>On</u></td><td><u>Off</u></td><td><u>Off</u></td><td><u>Off</u></td></tr> <tr><td>3</td><td>On</td><td>Off</td><td>On</td><td>Off</td></tr> <tr><td>4</td><td>Off</td><td>Off</td><td>Off</td><td>On</td></tr> <tr><td>5</td><td>Off</td><td>Off</td><td>On</td><td>On</td></tr> <tr><td>6</td><td>On</td><td>Off</td><td>Off</td><td>On</td></tr> <tr><td>7</td><td>On</td><td>Off</td><td>On</td><td>On</td></tr> <tr><td>8</td><td>Off</td><td>On</td><td>Off</td><td>Off</td></tr> <tr><td>9</td><td>Off</td><td>On</td><td>On</td><td>Off</td></tr> <tr><td>10</td><td>On</td><td>On</td><td>Off</td><td>Off</td></tr> <tr><td>11</td><td>On</td><td>On</td><td>On</td><td>Off</td></tr> <tr><td>12</td><td>Off</td><td>On</td><td>Off</td><td>On</td></tr> <tr><td>13</td><td>Off</td><td>On</td><td>On</td><td>On</td></tr> <tr><td>14</td><td>On</td><td>On</td><td>Off</td><td>On</td></tr> <tr><td>15</td><td>On</td><td>On</td><td>On</td><td>On</td></tr> </tbody> </table> Controller with one control output: <table border="0"> <thead> <tr> <th></th> <th>Out. 1</th> <th>Alarm 1</th> <th>Alarm 2</th> </tr> </thead> <tbody> <tr><td>0</td><td>Off</td><td>Off</td><td>Off</td></tr> <tr><td>1</td><td><u>Off</u></td><td><u>On</u></td><td><u>Off</u></td></tr> <tr><td>2</td><td>On</td><td>Off</td><td>Off</td></tr> <tr><td>3</td><td>On</td><td>On</td><td>Off</td></tr> <tr><td>4</td><td>Off</td><td>Off</td><td>On</td></tr> <tr><td>5</td><td>Off</td><td>On</td><td>On</td></tr> <tr><td>6</td><td>On</td><td>Off</td><td>On</td></tr> <tr><td>7</td><td>On</td><td>On</td><td>On</td></tr> </tbody> </table>		Outp. 1	Outp. 2	Alarm 1	Alarm 2	0	Off	Off	Off	Off	1	<u>Off</u>	<u>Off</u>	<u>On</u>	<u>Off</u>	2	<u>On</u>	<u>Off</u>	<u>Off</u>	<u>Off</u>	3	On	Off	On	Off	4	Off	Off	Off	On	5	Off	Off	On	On	6	On	Off	Off	On	7	On	Off	On	On	8	Off	On	Off	Off	9	Off	On	On	Off	10	On	On	Off	Off	11	On	On	On	Off	12	Off	On	Off	On	13	Off	On	On	On	14	On	On	Off	On	15	On	On	On	On		Out. 1	Alarm 1	Alarm 2	0	Off	Off	Off	1	<u>Off</u>	<u>On</u>	<u>Off</u>	2	On	Off	Off	3	On	On	Off	4	Off	Off	On	5	Off	On	On	6	On	Off	On	7	On	On	On	▲, ▼
	Outp. 1	Outp. 2	Alarm 1	Alarm 2																																																																																																																									
0	Off	Off	Off	Off																																																																																																																									
1	<u>Off</u>	<u>Off</u>	<u>On</u>	<u>Off</u>																																																																																																																									
2	<u>On</u>	<u>Off</u>	<u>Off</u>	<u>Off</u>																																																																																																																									
3	On	Off	On	Off																																																																																																																									
4	Off	Off	Off	On																																																																																																																									
5	Off	Off	On	On																																																																																																																									
6	On	Off	Off	On																																																																																																																									
7	On	Off	On	On																																																																																																																									
8	Off	On	Off	Off																																																																																																																									
9	Off	On	On	Off																																																																																																																									
10	On	On	Off	Off																																																																																																																									
11	On	On	On	Off																																																																																																																									
12	Off	On	Off	On																																																																																																																									
13	Off	On	On	On																																																																																																																									
14	On	On	Off	On																																																																																																																									
15	On	On	On	On																																																																																																																									
	Out. 1	Alarm 1	Alarm 2																																																																																																																										
0	Off	Off	Off																																																																																																																										
1	<u>Off</u>	<u>On</u>	<u>Off</u>																																																																																																																										
2	On	Off	Off																																																																																																																										
3	On	On	Off																																																																																																																										
4	Off	Off	On																																																																																																																										
5	Off	On	On																																																																																																																										
6	On	Off	On																																																																																																																										
7	On	On	On																																																																																																																										
☞	<i>HYSL</i>	defines the hysteresis for On/Off control	0... <u>0.5</u> ...20% of the measuring range	▲, ▼																																																																																																																									
☞	<i>LLiL</i>	defines the lower-range value (low limit)	depends on the sensor FS depends on the sensor	▲, ▼																																																																																																																									
☞	<i>HLiL</i>	defines the upper-range value (high limit)	depends on the sensor FS depends on the sensor	▲, ▼																																																																																																																									
☞ or	PV	return to the main operator level or to 2. menu level																																																																																																																											
☞ for at least 6 s	<i>LCAL</i>	lower calibration point for recalibration	depends on the sensor FS depends on sensor	▲, ▼																																																																																																																									
☞	<i>HCAL</i>	upper calibration point for recalibration	depends on sensor FS depends on sensor	▲, ▼																																																																																																																									
☞		return to the main operator level																																																																																																																											

Selftune

Automatic selftune

Remarks

The existing PID parameters are replaced.

If the controller is operating in on/off control, automatic selftune is aborted with the **AtEr** message. Selftune is also aborted when setpoint and actual process variables are very close initially or when the heating/cooling power is not enough to reach the adjusted setpoint.

Depending on the system's response time, the selftune process may require more than 2 hours.

1. Ensure that the controller is adjusted appropriately (type of sensor, °C/°F, resolution, lower- and upper-range values).
2. Ensure that the parameters for the proportional ranges Pb and $L Pb$ are not equal to zero (On/Off control), since no self-tuning can otherwise take place.

3. Wait until the current process variable is clearly different from the adjusted setpoint.

Notice

Selftune is at its best if the system is started from the onset ("cold start").

4. Start the selftune process by pressing **[AT]** for at least 6 s.

During the active self-tuning phase, a LED flashes on the right side of the upper display.

5. If necessary, abort the selftune process with **[AT]**.

As soon as selftune is terminated, the LED stops flashing. The PID parameters found are taken over automatically.

Manual adjusting of a PID controller

In some cases, it may be necessary or useful to manually optimise the parameters.

Remarks

Since the control parameters Pb , t_d and t_i are not independent of each other, only one parameter should be changed in small steps at a time whilst observing the control action, before making any further changes.

Control	Control action	Remedy
Proportional component	too slow reaction drastic overshooting, oscillation	decrease Pb increase Pb
Integral component	too slow reaction instability, oscillation	decrease t_i increase t_i
Differential component	too slow reaction drastic overshooting, oscillation	increase t_d decrease t_d

Tab. 1

Manual setting of a PID controller according to the Ziegler-Nichols method

If the selftune possibility is not utilised, the Ziegler-Nichols method can be applied to manually define the control parameters of a PID controller.

1. To switch off the parameter, set integral action time t_i and derivative action time t_d to 0.
2. Set the proportional range Pb at a high start value and observe or record the control action.

3. Reduce parameters Pb until a stable oscillation of the control variable is achieved. Note the value Pb adjusted for it as $P(\text{oscillate})$.
4. Measure the period duration T_c of the oscillation in seconds (see fig. 5).

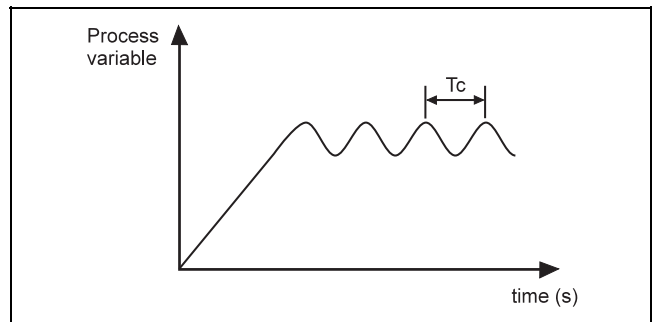

Fig. 5

Z-18818

5. The control parameters can be calculated from this measured value according to the following formula:
 Proportional range $Pb = 1.7 \times P(\text{oscillate})$
 Derivate time (rate) $t_i = 0.5 \times P(\text{oscillate})$
 Integral time (reset) $t_d = 0.125 \times T_c$
6. Enter the parameters into the controller.

Ramps and alarms

Ramps

If a ramp rate was configured, the process reaches the setpoint via a linear ramp.

The ramp rate is set within range 0 to 200 °C with parameter rr . The ramp function is disabled when the parameter rr set to 0.

Alarms

The alarms can be used for a minimum or maximum value monitoring of the process variable or of the control deviation.

Optionally, the first alarm signal can be suppressed, e.g. when starting up a furnace and a minimum nominal value is monitored, due to a low initial temperature. No alarm is signalled at this stage, but signalling occurs when the temperature first exceeds the minimum value and falls back to a value below the alarm set point.

Timer (time alarm)

The first alarm relay can also be configured for a timer function.

To do this, the value 12 or 13 is set for parameter $AL\bar{n}l$. A time between 0 and 3600 min is preset for parameter $ASP l$.

After switching on the supply voltage, the time function of the alarm relay is activated. The timer starts when the process variable has reached the setpoint. After the run out of the preset time the alarm relay is switched on ($AL\bar{n}l = 13$) in order to send a signal or switch on a device. Alternatively the alarm relay is switched off ($AL\bar{n}l = 12$) after the run out of time in order to switch off a device (e.g. even the power supply of the controller itself).

Example

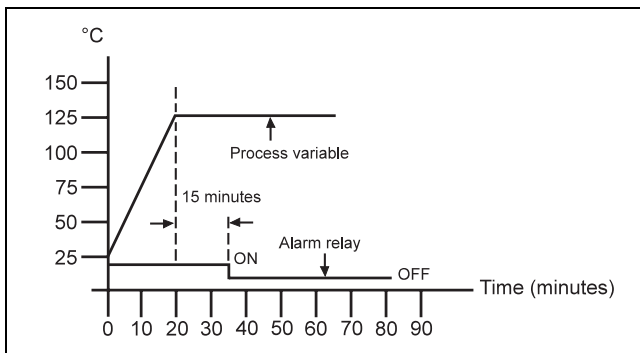

Fig. 6
Z-18817

The value for the ramp rate of the setpoint was set to 5 °C/min and a timer function was configured ($AL\bar{n}l = 12$, $ASP l = 15$).

At the time $t = 0$ the control begins by connecting the supply voltage. Since a ramp rate was set, the temperature increases at a speed of 5 °C/min to a setpoint of 125 °C. On reaching the setpoint, the timer is started. After expiry of the preset 15 minutes, alarm relay 1 opens and can then switch off a unit, including for instance the controller itself.

By using the 2nd timer function ($AL\bar{n}l = 13$), the alarm relay function can be inverted: the alarm relay initially remains open and closes upon reaching the setpoint and after expiry of the preset time.

Option: Retransmission of process variables

(to be released soon)

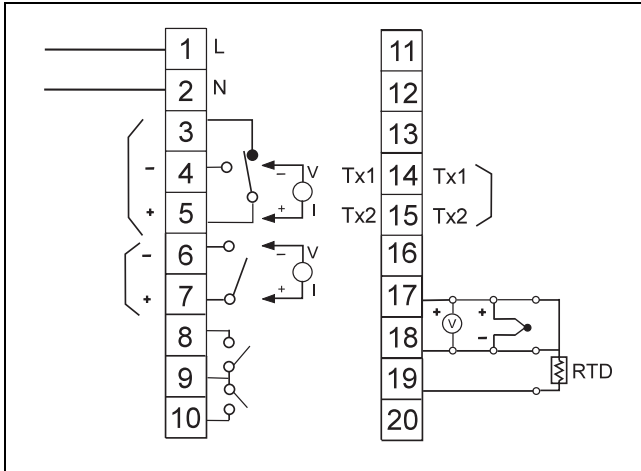

Fig. 7 Wiring diagram
 Z-18791 1, 2 Power supply
 3, 4, 5 Control output 1
 6, 7 Control output 2
 8 Alarm 1
 9 Alarm Com.
 10 Alarm 2
 14, 15 Retransmission of process variables
 17, 18
 19 Sensor input (RTD, TC, mA)

The terminals designated as “Tx1” and “Tx2” can be used optionally for retransmission of process variables:

This supplies an output signal of 0/4...20 mA, which corresponds to the input or process variable. The parameter *Addr* has to be set according to the following table:

PV output	<i>Addr</i>
0...20 mA	196
4...20 mA	192

The appropriate method to use is determined by the rating plate (see Section on “Identifying the units”).

Calibration

Notice

The units are precalibrated at the factory. They should be recalibrated (according to the following steps) only when absolutely necessary.

The existing calibration data is then unredeemable.

As a principle, recalibration means that suitable calibration equipment is available.

1. It must be safeguarded that the controller is correctly adjusted (type of sensor, °C/°F, resolution, lower-range value, upper-range value).
2. Switch off the power supply.
3. Instead of sensor, connect a calibration unit to the input terminals (ensure correct polarity!) and generate a calibration signal which corresponds to the lower calibration value (e.g. 0 mV for 0 °C).
4. Switch on the power supply.
5. Select the parameter for the lower calibration value *LCAL* on the 3rd menu level (see Section on “Parameter definition”).
6. Adjust the displayed value with ▲ and ▼ until this corresponds with the calibration value.
7. Press [AT] for at least 6 s in order to store this value.
8. Select the parameter for the upper calibration value *HCAL* on the 3rd menu level (see Section on “Parameter definition”).
9. Generate a calibration signal which corresponds to the upper calibration value (e.g. 46 mV for 800 °C).
10. Adjust the displayed value with ▲ and ▼ until this corresponds to the calibration value.
11. For at least 6 s press [AT] to store this value.
12. Return to the standard level with [AT].
13. Switch off the power supply.
14. Instead of the calibration unit, connect the sensor to the input terminal (ensure correct polarity!).
15. Switch on the power supply.

Error messages

Error message	Possible cause	Remedy
<i>SbEr</i>	sensor break, sensor incorrectly connected	check the sensor connection, exchange sensor
<i>LLEr</i>	lower-measuring range undershot	check the setting of the parameter <i>LL, t</i> and correct
<i>HLEr</i>	upper-measuring range overshoot	check the setting of the parameter <i>HL, t</i> and correct
<i>AEr</i>	analog output is defective	look for external error sources (parasitic pulses), consult your after-sales service
<i>AEr</i>	self-tuning unsuccessful, ON/OFF control configured (<i>Pb=0</i>)	repeat the self-tuning, <i>Pb</i> set unequal to 0
<i>oPEr</i>	manual operation is not allowed during ON/OFF control	<i>Pb</i> set unequal to 0
<i>CSEr</i>	checksum error	check control parameter and re-adjust

Tab. 2

Maintenance

Caution

When the instrument is connected to its supply, terminals may be live and the opening of covers or removal of parts except those to which access can be gained by hand is likely to expose live parts.

The instrument shall be disconnected from all voltage sources before it is opened for any operations. Operations on the opened instrument under voltage must only be performed by an expert who is aware of the hazard involved.

Capacitors inside the instrument may still be charged even if the instrument has been disconnected from all voltage sources.

Only fuses of the specified type and rated current may be used as replacements. Makeshift fuses may not be used. The fuse-holder may not be short-circuited.

Whenever it is likely that protection has been impaired, the instrument shall be made inoperative and be secured against any unintended operation.

It must be assumed that the protection has been impaired when

- the instrument has visible signs of damage,
- the instrument no longer functions,
- the instrument has been stored in unfavorable conditions for a long time
- the instrument has been subjected to adverse transport conditions.

Conversion

⚠ Caution

When the instrument is connected to its supply, terminals may be live and the opening of covers or removal of parts except those to which access can be gained by hand is likely to expose live parts.

The instrument shall be disconnected from all voltage sources before it is opened for any operations. Operations on the opened instrument under voltage must only be performed by an expert who is aware of the hazard involved.

Capacitors inside the instrument may still be charged even if the instrument has been disconnected from all voltage sources.

Only fuses of the specified type and rated current may be used as replacements. Makeshift fuses may not be used. The fuse-holder may not be short-circuited.

Whenever it is likely that protection has been impaired, the instrument shall be made inoperative and be secured against any unintended operation.

It must be assumed that the protection has been impaired when

- the instrument has visible signs of damage,
- the instrument no longer functions,
- the instrument has been stored in unfavorable conditions for a long time
- the instrument has been subjected to adverse transport conditions

Changing the measuring input



Bild 8 R1 resistor
Z-18825 J2 solder jumper
J3 solder jumper

If the controller is to be used for a measuring input other than the one preset,

1. The soldered jumpers J2 and J3 must be closed or opened in accordance with the following table or the resistor R1 should be installed or removed.

Input	J2	J3	R1 (1%, 0.25 W)	Parameter in
Thermocouple	open	closed	no resistor	0, 1, 2, 3, 4, 5, 6 or 7
Resistance thermometer Pt100	open	open	no resistor	8 or 9
Current	closed	open or closed	2.8 Ω	10
Voltage (-10...60 mV)	closed	open or closed	no resistor	10

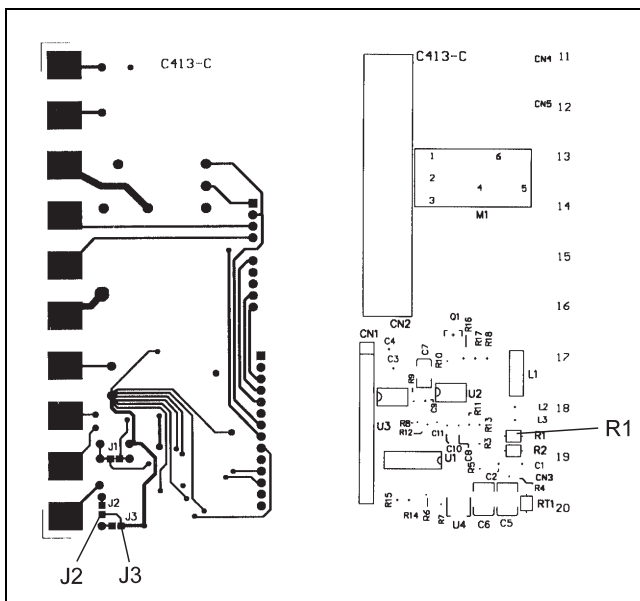
Tab. 3

2. The sensor type (parameter π) and the measuring range thresholds (parameter LL, t and HL, t) must be readjusted accordingly
3. The controller must be recalibrated (see Section on "Calibration").

Application

The controller is designed to solve simple, basic control tasks, especially in the field of temperature control.

Description

The control task can be done with P, PI, PD, PID or a simple On/Off action. The right controller parameters are traced with an automatic self-tune function. In the ensuing operation, a Fuzzy Logic feature is used to effect an indirect adaption of the controller parameters, which have the effect of optimising and stabilising the control action even outside the stationary condition (e.g. during big setpoint jumps).

The alarm function is selectable. Apart from the minimum or maximum value monitoring of the process variable or of the control deviation, it can also be used as a time relay. Additionally, a further function such as ramp rate can be adjusted for the setpoint.

All settings can be stored in a non-volatile memory and thus remain unaffected by any power supply interruptions.

Technical data

Input

Types

Sensor	Measuring range	Error
Thermocouple Type J	-50...999 °C	±2 °C
Thermocouple Type K	-50...1370 °C	±2 °C
Thermocouple Type T	-270...400 °C	±2 °C
Thermocouple Type E	-50...750 °C	±2 °C
Thermocouple Type B	300...1800 °C	±3 °C
Thermocouple Type R	0...1750 °C	±2 °C
Thermocouple Type S	0...1750 °C	±2 °C
Thermocouple Type N	-50...1300 °C	±2 °C
Pt100 (DIN or JIS)	-200...400 °C	±0,4 °C
Linear (-10...60 mV)	-1999...9999	±0,05 %

Reference junction compensation
0.1 % of the ambient temperature

Correction of process variable
adjustable

Option
0/4...20 mA input

Resolution
15 bit

Outputs

Control relays
3 A / 240 V AC resistive load

Alarm relays
2 A / 240 V AC resistive load

Optional
continuous outputs 0/4...20 mA (maximum load 500 Ω)

Resolution
8 bit

Display

Process variable
4-digit, red LED

Setpoint
4-digit, green LED

Green or red status LED for control or alarm relays

Power supply

90...264 V AC, 50/60 Hz or
24 V UC (20...32 V AC/DC)

Power consumption
< 5 VA

Housing

Front
96 × 96 mm

Panel cutout
92 × 92 mm

Installation depth
53 mm

Mass
300 g

Type of protection
Front: IP 54

Electrical connection
with screw terminals (IP 00)

Environmental conditions

Ambient temperature
-10...50 °C

Storage and transportation temperature
-20...70 °C

Relative humidity
0...90 %
no condensation

Insulation
20 MΩ (500 V DC)

Vibration immunity
10...55 Hz, 1 mm

Immunity to shock
20g

Electromagnetic compatibility / Safety

Interference resistance
according to EN 50 082-2

Interference emission
according to EN 55 011, class B

UL, CSA and CE certificate

CPU

Sample rate
3 / s

Retransmission (option)

Retransmission of process variable 0/4...20 mA

Resolution
15 bit

Packaging for transport or for return to manufacturer

If the original packing is no longer available, the instrument must be wrapped in an insulating air foil or corrugated board and packed in a sufficiently large crate lined with shock absorbing material (foamed material or similar) for the transportation. The amount of cushioning must be adapted to the weight of the unit and to the mode of transport.

The crate must be labelled "Fragile".

For overseas shipment the unit must additionally be sealed airtight in 0.2 mm thick polyethylene together with a desiccant (e.g. silica gel). The quantity of the desiccant must correspond to the packing volume and the probable duration of transportation (at least 3 months). Furthermore, for this type of shipment the crate should be lined with a double layer of kraft paper.

Subject to technical changes.

This technical documentation is protected by copyright. Translating, photocopying and disseminating it in any form whatsoever - even editings or excerpts thereof - especially as reprint, photomechanical or electronic reproduction or storage on data processing systems or networks is not allowed without the permission of the copyright owner and non-compliance will lead to both civil and criminal prosecution.



ABB Automation Products GmbH

Hoeseler Platz 2
D-42579 Heiligenhaus
Phone +49(0)20 56 12 - 51 81
Fax +49(0)20 56 12 - 50 81
<http://www.abb.com>

Subject to technical changes.
Printed in the Fed. R. of Germany
42/61-70 EN Rev. 01
Edition 12.01