

INSTRUMENT TRANSFORMERS WITH ABB RESIVOLT™ TECHNOLOGY

## VOG-20BR

### Outdoor voltage transformer



#### Product features

- 34.5 kV, outdoor, 200 kV BIL, 60 Hertz
- Strike: 21.6" (549 mm); Creep: 50.2" (1277 mm)
- Minimum operating temperature: -50° C
- Approximate weight: 125 lbs. (57 kg)

#### Application

The VOG-20BR is designed with ResiVolt technology to withstand challenging environments where very fast transient over-voltages (VFTO) are present, such as those caused by line switching devices. An optimal solution for line-to-ground metering applications, the VOG-20BR offers superior performance in a compact design. Tapped and dual secondary windings are also available upon request.

#### Industry leading performance

The VOG-20BR offers improved reliability and increased safety in renewable metering and recloser applications, as well as in areas where increased line switching is present. The unit provides superior withstand capability against steep wave power network transients. An enhanced creep distance and intelligent shed design minimize flashover potential and provide superior heat dissipation. Encapsulated in field-proven HCEP material (hydrophobic cycloaliphatic epoxy), the VOG-20BR delivers unparalleled performance in outdoor applications, including heavily polluted and coastal environments.

The VOG-20BR is a robust voltage transformer that uses ResiVolt™ transient resistant technology for line-to-ground applications, with enhanced design for operation in renewable and frequent line switching installations.

#### Terminals

The electro-tin plated primary H1 bushing terminal accommodates #10 to 250 MCM conductors. The H2 neutral terminal is insulated to withstand a 19 kV test level and can be disconnected from the external ground cable for power factor measurement. Clamp-type secondary terminals accommodate #14 through #3 wire. Stud type terminals (0.750-16 x 1.125), ideal for use in primary metering cabinets and other applications, are available upon request.

#### Junction box

The junction box has a 1" conduit hub on either end and a knock out for a 1" conduit fitting on the bottom. The box is anchored to the body of the transformer with screws and can be easily detached, simplifying installation and change-out procedures.

#### Baseplate

The base is constructed of corrosion-resistant aluminum and is secured to the encapsulated base support.

#### Mounting

The VOG-20BR can be mounted in upright or cantilever positions. Stress relief devices should be used to support cable connections where applicable.

## Test reports

Test reports are stored electronically and can be e-mailed in various formats at the time of shipment.

## Standards

This unit meets or exceeds all requirements of IEEE C57.13-2016 and can be tested to other standards as requested. It also meets and exceeds IEC 61869-3,

clause 7.2.3 and CAN/CSA 411.1, clause 6.6 requirements for basic impulse and fast impulse transient withstand.

## Warranty

Transformers with ABB ResiVolt technology are provided with a 3-year warranty.

## Dimensions (inches [mm])

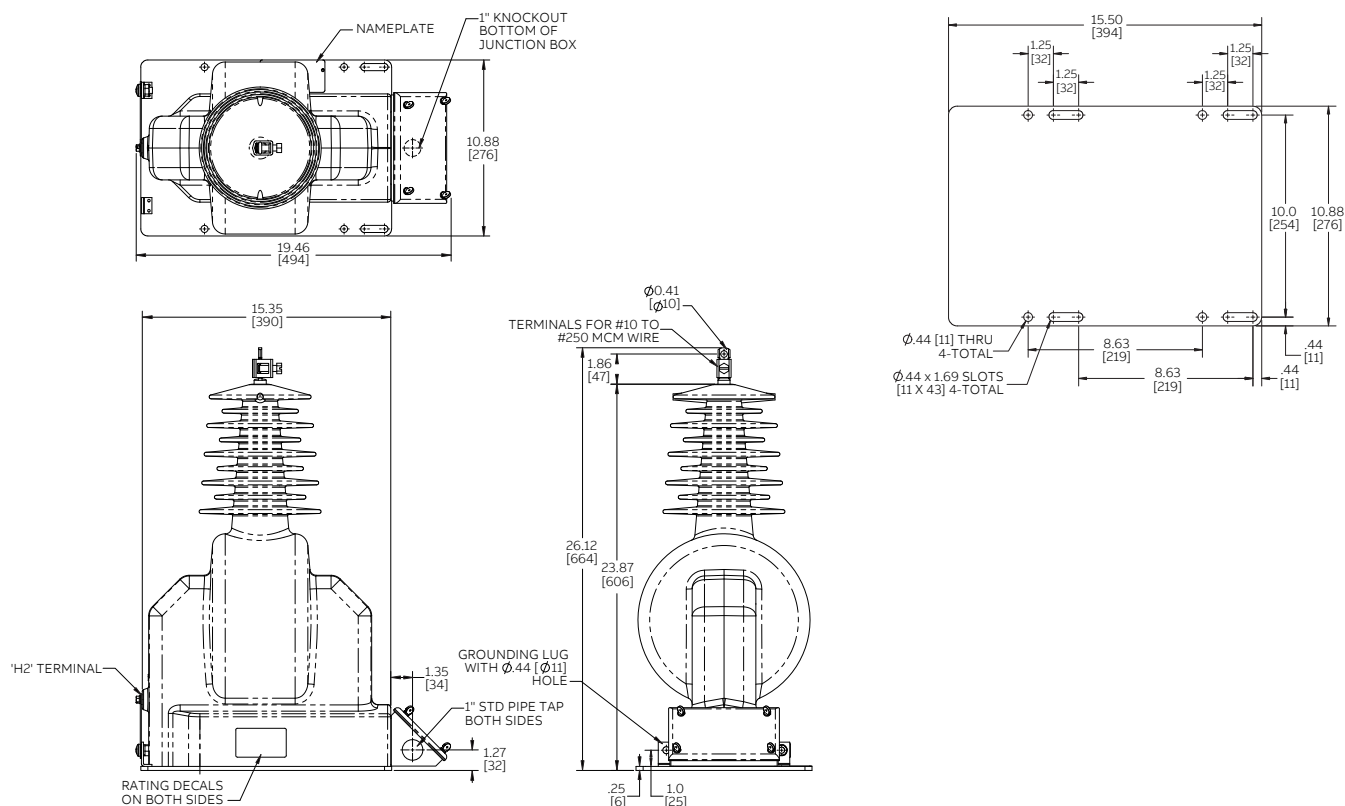

## Selection guide

Primary voltage	Secondary voltage	Winding ratio	Metering accuracy	Thermal rating at 30° C	Rated voltage factor (RVF)*	Style number
19920/34500GY	120	166:1	0.3Y	1500	1.9	E-923A602G02
20125/34500GY	115	175:1	0.3Y	1500	1.9	E-923A602G01
20125/34500GY	115/67.08	175/300:1	0.3Y/0.3Y	1500	1.9	E-923A611G02

\* RVF for 8 hours

Additional styles available upon request. Contact your ABB sales representative or call +1-252-827-3212 for more information.