

# Pressure Compensation Valve Installation instruction

For use with all ACH, ACQ, ACS 580-01 IP66 (UL Type 4X) Drives with H358 (cable box with no holes)

Kit: 3AXD50000957255

Includes: (1) Pressure compensation valve; (1) back nut

1. Make a hole in the cable box for the valve as shown below.

**IMPORTANT** – Remove cable box from drive before making the hole to prevent metal shavings from entering the drive.

a. Remove the cover, then remove the cable box.

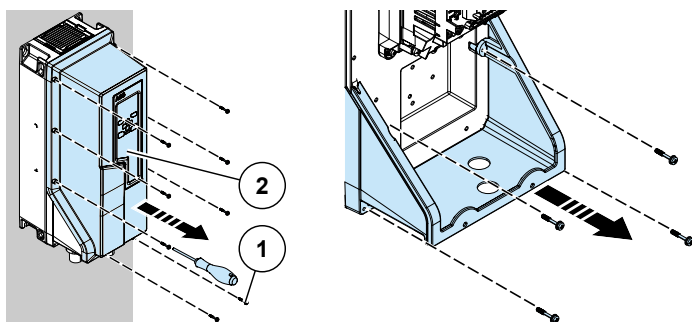

Screwdriver: Pozidriv #2  
Torque: Tighten to 1.8 lbf-ft (2.5 Nm)

b. Make a hole in the cable box: 12 mm (31/64 in) dia., centered at the mark. Deburr the hole.

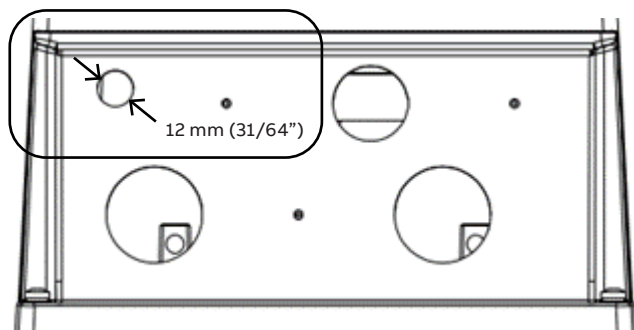

R1 & R2

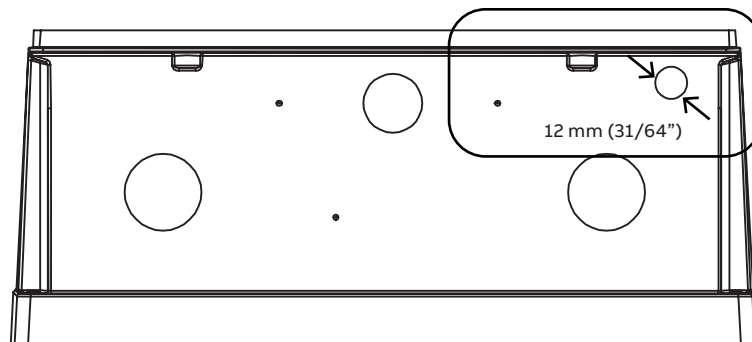

R3

2. Insert and tighten the pressure compensation valve using back nut. Valve faces out; nut goes inside.



• 0.7 Nm (6 lbf-in)

3. Reinstall cable box and cover. Torque screws to the specifications shown above.



**WARNING!** Screws must be correctly torqued to ensure a water-tight seal. Hand tools only! Do not use power tools!

