



# SSC600 AND SSC600 SW

Centralized and virtualized protection and control -  
Examples and features

**ENGINEERED  
TO OUTFIT**

---

# Contents

**01.** Introduction

**02.** Customer benefits

**03.** Centralized protection and control features

**04.** Solution examples

---

# Contents



**Introduction**



**Customer benefits**



**Centralized protection and control features**





**Solution examples**

# Introduction

## Smart Substation Control and Protection SSC600

 **SSC600** incorporates centralized protection, control and monitoring functionalities to offer a superior solution to utility and industrial customers for the entire duration of the substation's life cycle.

 With software based on existing Relion technology it is designed for a wide range of power distribution applications – from basic feeder protection and control to complex multibay substation applications.

 The software can be flexibly modified anytime to adapt to changing network requirements.

 Allows viewing and monitoring processes on substation level from a centralized point.

 Industrial computer technology allows fast utilization of modern high-performance computing and reliable operation (no moving parts, redundant power supply).

 Turnkey tested and verified product including hardware and software in the same package.



# Introduction

## Smart Substation Control and Protection SSC600 SW

 **Smart substation control and protection SSC600 SW** has the same functionality as SSC600 but only the software (no hardware included)

 Delivered as virtual machine – KVM or VMWare

 Benefits of virtualization also for the real-time functionalities.

 All same external interfaces as SSC600 – IEC 61850, IEEE 1588 v2, PRP, WHMI, etc.

 Freely choose computer – it just needs to fulfill the minimum requirements.

 Same performance as embedded protection devices – protection speeds, communication latencies, and event reporting.

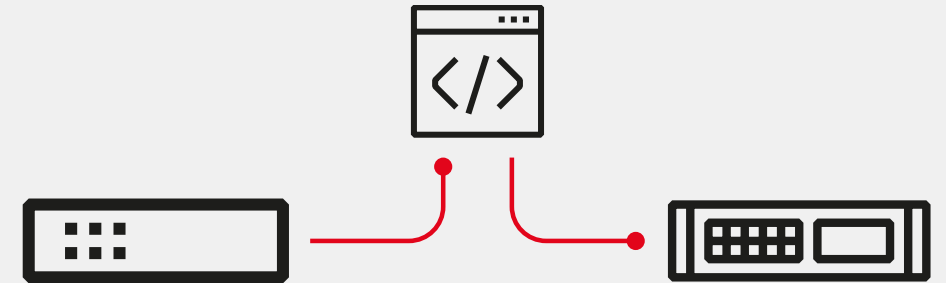

# Merging units



## REX600

- One single unit for all measurements and I/O for a single bay – with standard wiring and design on bay level
- Support for non-conventional instrument transformers
  - 4Is + 4Us
  - 6BI + 3BO
- Fulfilling IEC 61869-13 SAMU requirements with backup protection and disturbance recorder
- Supports both IEC 61850-9-2LE and IEC 61869-9 sampled value publishing



## REX615

- Up to 8 CT + 8 VT
- Up to 32 BI + 21 BO
- Up to 3 Is + 3 Us + 1 CT



## REX640

- Up to 12 CT + 8 VT or 11 CT + 9 VT or 10CT + 10 VTs
- Up to 6 Is + 6 Us + 2 CT + 2 VT or 12 Is + 12 Us
- Up to 96 BI + 10 BO or 56 BI + 42 BO

# Introduction

## Example applications

SSC600 comes with convenient, ready-made application packages that can be flexibly combined to meet application-specific requirements.

The available packages support the following applications:

### Feeder/line protection

- Extensive overcurrent and earth-fault protection
- Fault locator
- Distance protection
- Line differential protection

### Power transformer protection

- Protection for two winding power transformers

### Motor protection

- Protection of asynchronous motors

### Power quality measurements

- Current and voltage distortions
- Voltage variation
- Voltage unbalance

### Shunt capacitor protection

- Protection of single Y, double Y and H-bridge connected capacitor banks
- Protection of harmonic filter circuits

### Interconnection protection

- Protection of interconnection points of distributed generation units
- Frequency protection

### On-load tap changer control

- Position indication
- Voltage regulation

### Busbar protection

- Protection against arc flash
- Low impedance-based busbar differential

# Application packages

## Package content

<b>Base functionalities*</b>	<b>Basic protection</b>	<b>Cable/line application (5-10-15-20-30 bays)</b>	<b>Transformer protection (0-2-4 bays)</b>	<b>Motor application (0-5-10-15-20-30 bays)</b>
Web HMI with station SLD	Current protection_50/51	Directional EF_67N	Thermal overload_49/T/G/C	Thermal overload_49M
Breaker monitoring	Earth-fault_50N/51N	3-ph. direct. reverse power_32R/32O	Transformer differential_87T	Neg.seq. OC for machines_46M
Measurements_3I/3V/In/Vn/f/...	3-phase undervoltage_27	Phase-discontinuity_46PD	Low-impedance REF_87NL	Loss of load supervision_37
Fault recorder	3-phase overvoltage_59	Thermal protection_49F	3-phase underimpedance_21G	Motor load jam_51LR
Disturb. recorder (centralized)	Residual overvoltage_59N	Autoreclosing_79	Tap-changer position indication_84M	Motor startup supervision_49/66/48/51LR
IEC 61850-9-2LE and IEC 61869-9	Neg.seq. overvoltage_47O-	Synchrocheck_25	<b>Bay-level applications (for selected and available streams)</b>	Phase reversal 46R
IEC 61850 GOOSE/ R-GOOSE/MMS/R-SV	Pos.seq. undervoltage_47U+	Directional OC_67P	Tap-changer indication and control with voltage regulator	Emergency startup_ESTART
Advanced logics	Negative-sequence OC_46	Fault passage indicator_67NFPI	Distance protection_21P, 21N	<b>Multi-bay level applications (up to 30 bays)</b>
Alarms	Frequency protection_81	<b>Advanced cable/line application (5-10-15-20-30 bays)</b>	Power quality	Load-shedding and restoration across 4 bus sections_81LSH
Events and audit log	Three-phase inrush detect._68HB	MF-admittance EF_67NYH	<ul style="list-style-type: none"> <li>Current total demand and harmonic distortion (TDD and THD)</li> <li>Voltage total harmonic distortion (THD)</li> <li>Voltage variation</li> <li>Voltage unbalance</li> </ul>	Low imp. busbar differential_87BL/87B
PRP redundant communication	Circuit-breaker failure_51BF	Admittance EF_21YN	Line differential protection_87L	Arc protection_50L/50NL
Redundant power supply	Switch onto fault_SOTF	Intermittent EF_67NIEF	<ul style="list-style-type: none"> <li>Up to 4 feeders</li> </ul>	<b>Shunt capacitor protection</b>
Time synch. with IEEE 1588 v2	Load blinder_21LB	Wattmetric EF_32N		3-ph overload_51,37,86C
Fuse failure supervision_VCM,60	<b>Communication protocols</b>	Low-voltage ride-through protection_27RT		Current unbalance_60N
Master trip_94/86	IEC 60870-5-104	Fault locator_21FL		3-ph current unbalance_60P
Anomaly detector ANOGAPC	DNP3	Direct. react. power underv._32Q/27		Cap. bank switching resonance_55ITHD

\*Always included

# Introduction

## Standard-compliant centralized protection and control



### Customer need

- All settings, configurations and applications centralized in one device
- Dynamically allocate the applications per bay with the possibility to change or adapt at anytime depending on the substation evolution (for instance, a feeder needs to be converted into a transformer bay in a very short time)



### Solution

- SSC600 combined with IEC 61850 and IEC 61869 merging units (MU)
- All settings, configurations and application in one device
- Any capable protection relay suitable as backup time master
- Substation gateway doubles up as human-machine interface (HMI)
- Combined or separated IEC 61850 network for process and station bus
- System visualization using SSC600 and its Web HMI (WHMI)
- Time synchronization via the IEEE 1588 v2 GPS (Global Positioning System) master

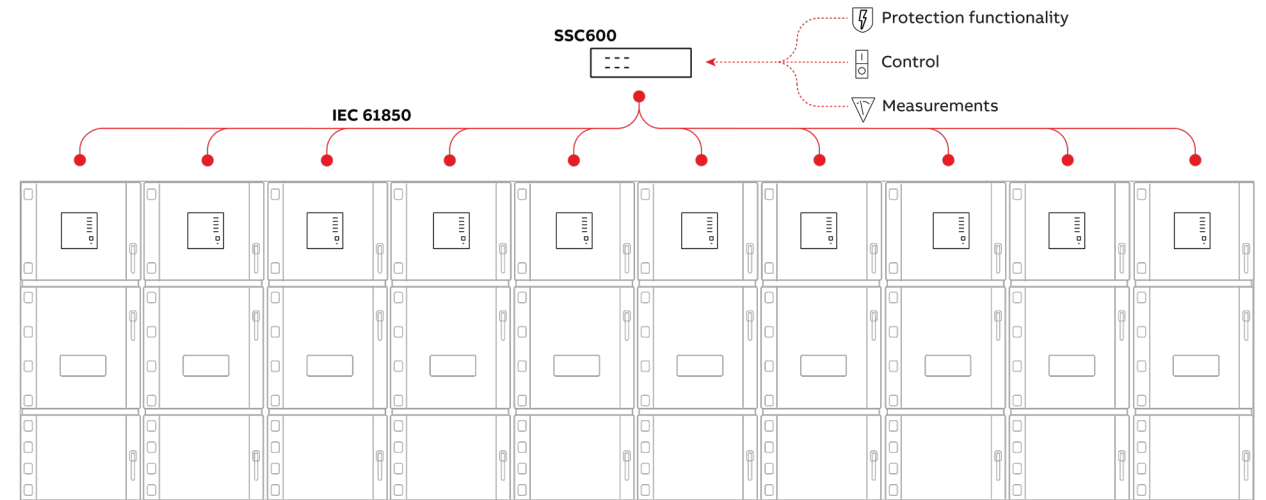

# Contents



**Introduction**

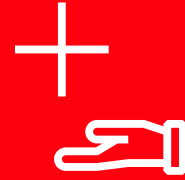

**Customer benefits**



**Centralized protection and control features**



**Solution examples**

# Customer benefits

## Innovative application and design

- A future-proof approach to protection and control in distribution networks – centralizing all protection and control functionality in one single device on substation level
- New and existing industry-leading products and functionality enabled across a wider field of application, such as ABB digital switchgear
- All needed protection and control functionality combined into this solution for wide application coverage
- Additional digital services that add value to the entire life cycle of the substation

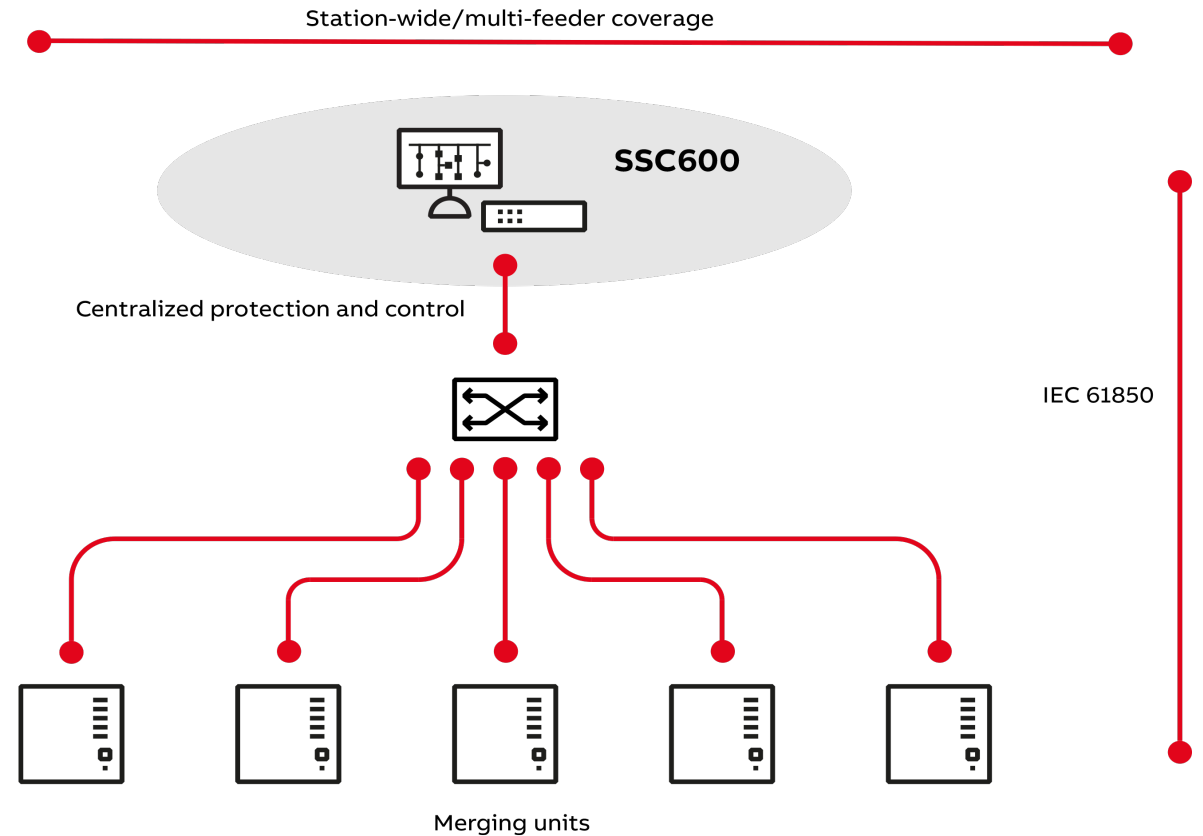

# Customer benefits

## Protection flexibility for changing power grids

### Flexibility to build optimal power distribution protection

- Adapt to changing network environments
- Extend the centralized protection and control solution at any time with minimized engineering (new feeder or new functionality)
- Prolong the lifetime of the installation by adding functionality to the existing protection scheme (protection always according to most recent innovations)

Minimized process downtime during maintenance work thanks to ease of device replacement and minimized engineering

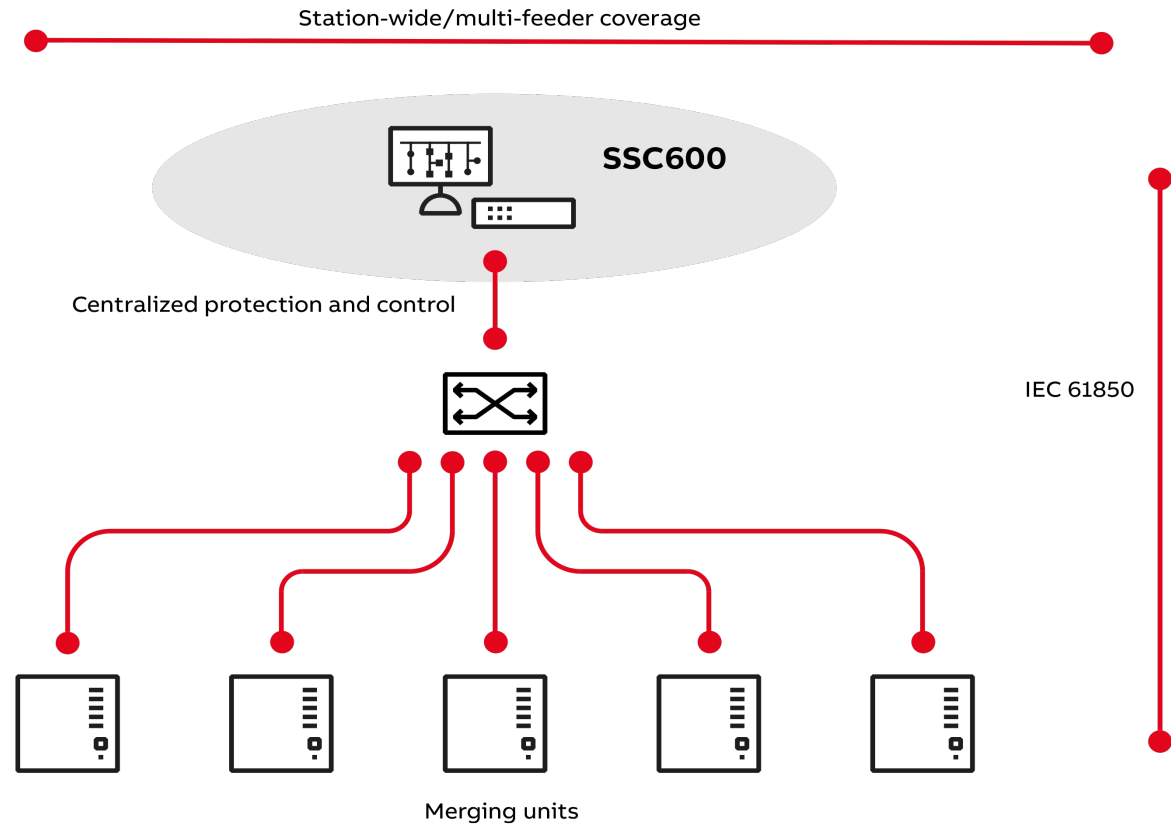

# Customer benefits

Ease of use for increasingly complex systems

The solution paves the way for minimized process downtime

- Better visibility of substation processes as data is concentrated at the substation level
- Reduced protection scheme complexity as all protection and control functionality is centralized in one device
- Easy device addition or replacement with minimized engineering effort

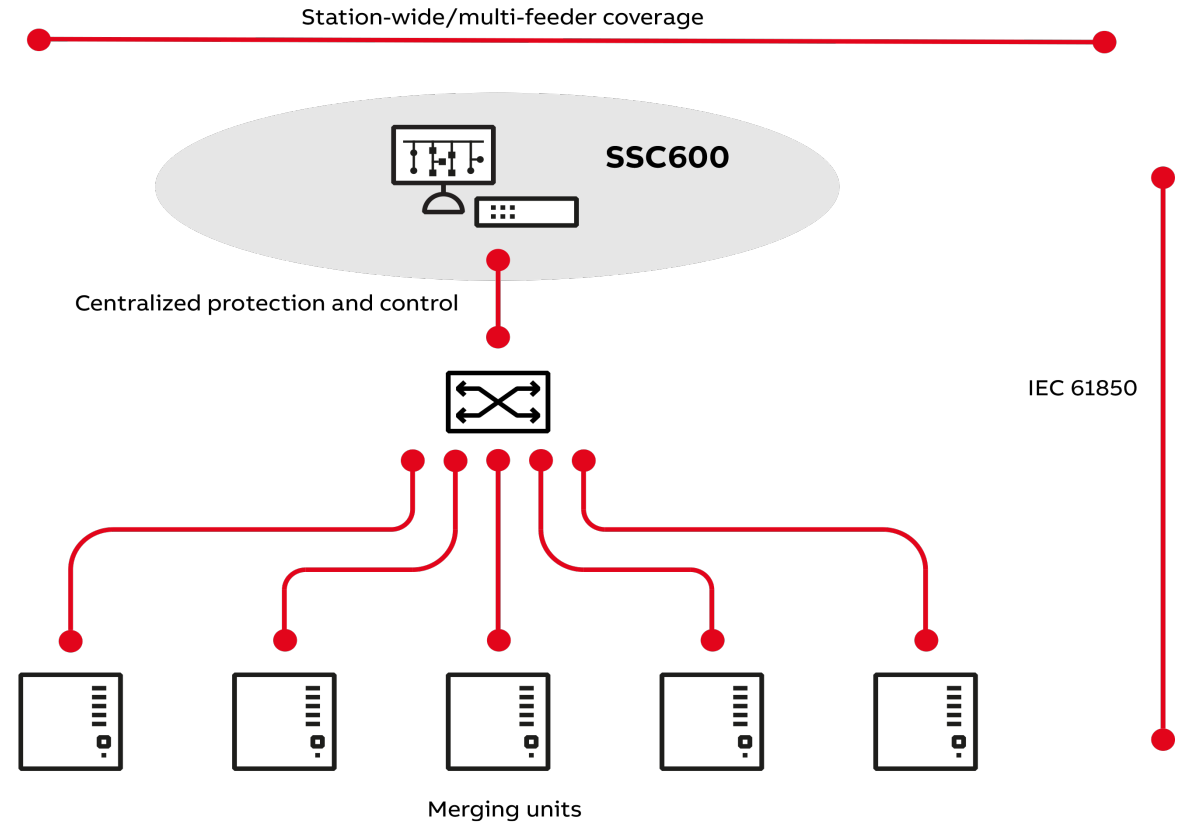

# Contents



**Introduction**



**Customer benefits**



**Centralized protection and control features**



**Solution examples**

# Centralized protection and control features

## Centralized fault analysis



### Customer need

- Substation-wide visibility with monitoring of network faults from a centralized point
- All substation-related fault data in one place



### Solution

Disturbance recordings covering the whole substation

- Recordings of all received analog channels with 80 samples per cycle (up to 30 streams)
- Recordings of up to 512 Boolean signals
- Storage space for thousands\* of COMTRADE files\*\*
- Maximum recording length 60 seconds

Sequence of events (SOE) for the whole substation

Fault record data of all protection events

Trigger recordings with dedicated anomaly detection function

\*Depending on recording length  
\*\*80 samples per cycle

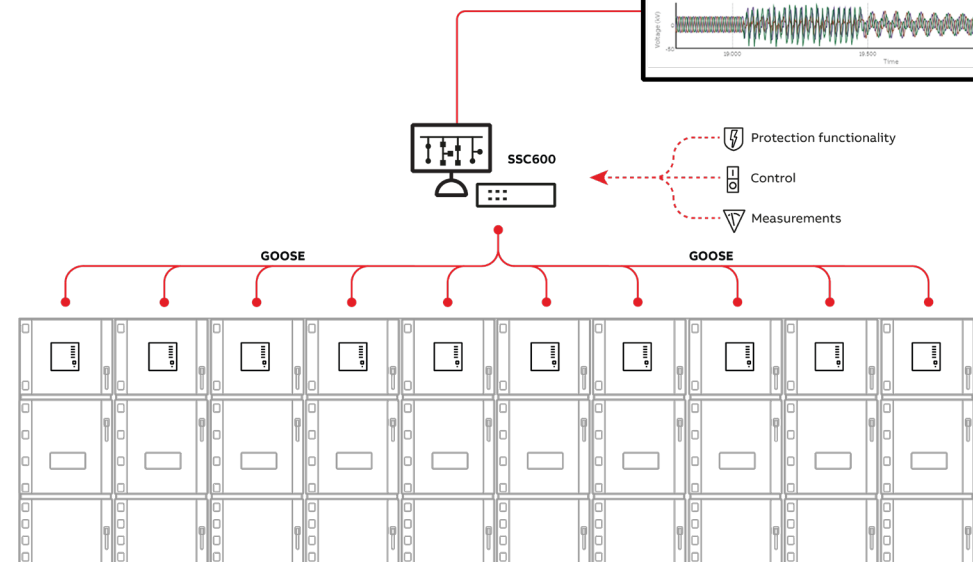
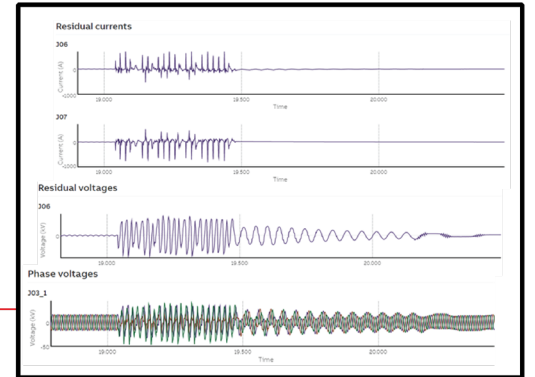

# Centralized protection and control features

## Centralized substation-level HMI



### Customer need

Centralized substation-level HMI

- Station-wide process visibility
- Annunciator functionality



### Solution

- Ability to monitor and control the whole substation via SLDs on the WHMI
- Easy access to events, fault records, disturbance recordings, settings and measurements
- Analyze the state of the electrical system with intuitive power quality trends and comprehensive self-supervision view
- Alarm annunciator functionality with remote I/Os:
  - Up to 300 alarm LEDs
  - Capability to receive up to 1,600 GOOSE values and use them in logics

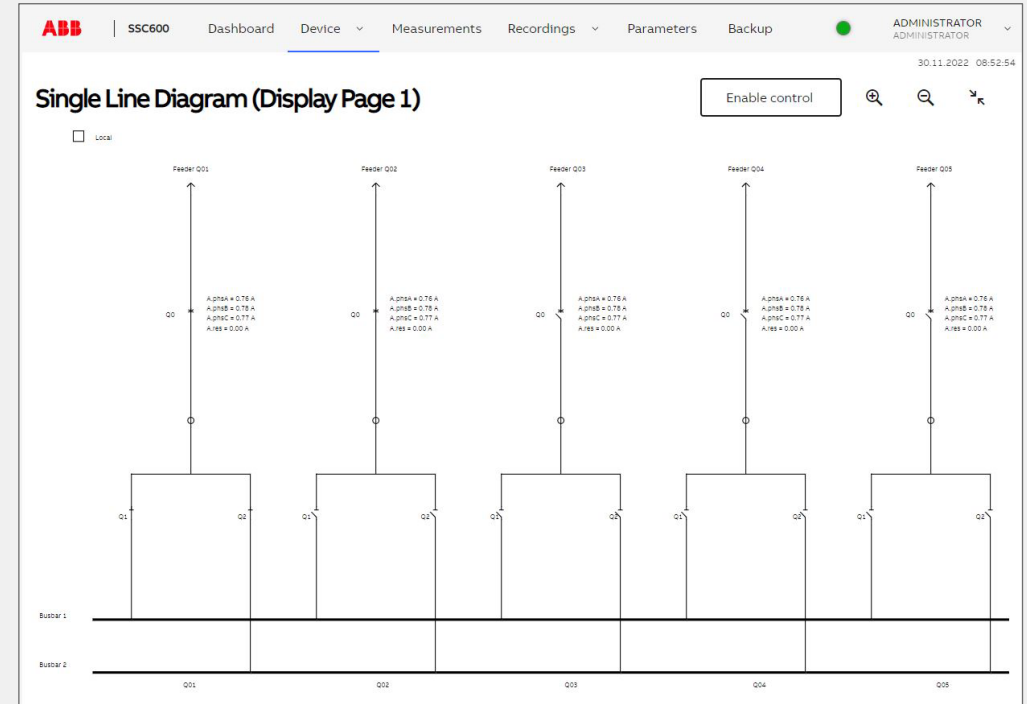

# Centralized protection and control features

## Easy-to-use interface



### Customer need

- Easy-to-use interface without using the relay setting and configuration tool PCM600
- Embedded local HMI (LHMI) functionalities



### Solution

- Intuitive WHMI for easy navigation
- Control of switching equipment
- Possibility to read and write parameter setting values to SSC600 via the WHMI
- Possibility to print parameter setting values via the WHMI

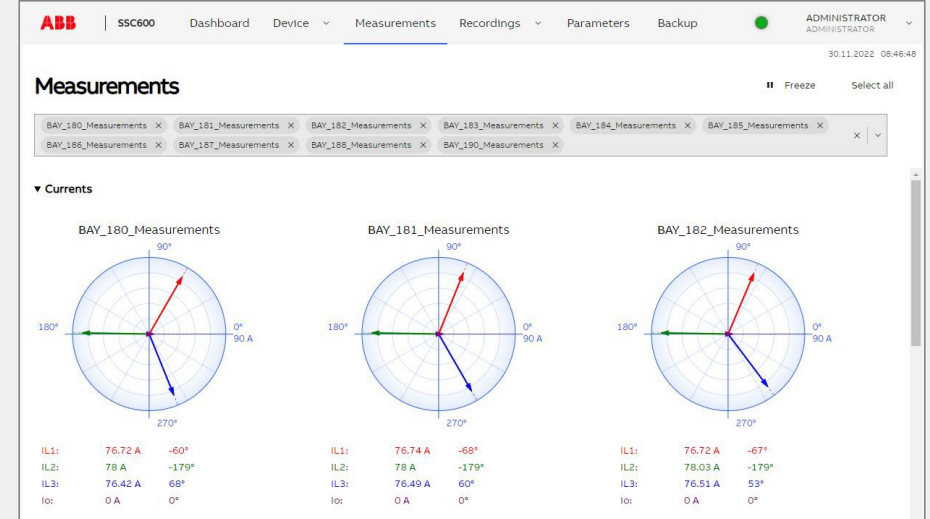

The screenshot shows the 'Device status' and 'Latest events' pages in the ABB SSC600 interface. The 'Device status' section shows the device is 'Ready'. The 'Latest events' section shows a list of events with the following columns: DATE & TIME, SOURCE, FUNCTION, DESCRIPTION, and VALUE.

DATE & TIME	SOURCE	FUNCTION	DESCRIPTION	VALUE
30.11.2022 09:24:11...	MainApp	MVGAPC: 5	Q6	False
30.11.2022 09:24:11...	MainApp	MVGAPC: 5	Q5	False
30.11.2022 09:24:11...	MainApp	MVGAPC: 5	Q4	False
30.11.2022 09:24:11...	MainApp	MVGAPC: 5	Q6	True
30.11.2022 09:24:11...	MainApp	MVGAPC: 5	Q5	True
30.11.2022 09:24:11...	MainApp	MVGAPC: 5	Q4	True
30.11.2022 09:24:10...	MainApp	MVGAPC: 5	Q6	False
30.11.2022 09:24:10...	MainApp	MVGAPC: 5	Q5	False
30.11.2022 09:24:10...	MainApp	MVGAPC: 5	Q4	False

The 'Active alarms' section shows one active alarm:

STATUS	NUMBER	DESCRIPTION	SOURCE
●	5	TRPPTRC 21	BAY_180_Protection

# Centralized protection and control features

## Ease of replacement via configuration backups



### Customer need

Standardization of equipment

- Engineering templates for easier and faster engineering
- Configuration backup for fast device replacement



### Solution

Protection relay and/or MU configurations backups always stored in SSC600

- Quick replacement of relay and/or MU
- New and replacement units plugged-in and configuration downloaded
- Quick system restoration with minimum downtime per configuration

Secure upload of SSC600 configuration backups to on-premise cloud or remote cloud to facilitate fleet management on-site or across multiple sites, remote upgrades and remote supervision

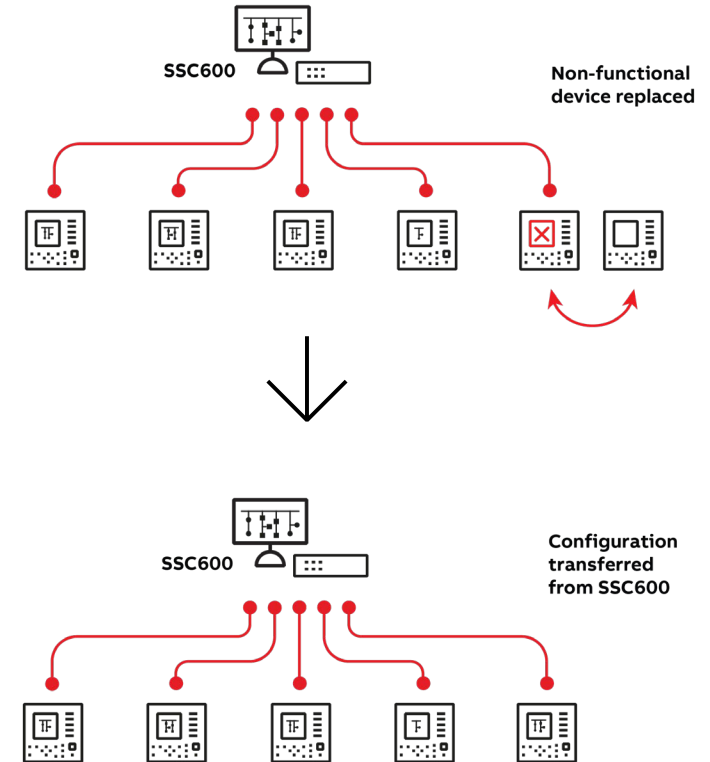

# Centralized protection and control features

## Centralized logics and configuration



### Customer need

- Flexibility to customize protection application for specific needs
- Easy-to-use PLC engineering interface
- Possibility to graphically troubleshoot and monitor programmable logics
- Centralized place for large logics with protection class operation reliability and performance



### Solution

- Extensive logical programming functionality with various logic functions
- Easy-to-use graphical application configuration interface in PCM600
- Online monitoring of the complete SSC600 application with PCM600
- Ability to receive hundreds of statuses and use them together with thousands of logical gates for highly demanding applications
- All station-level and bay-to-bay logics done centrally, for instance, interlockings in one single configuration

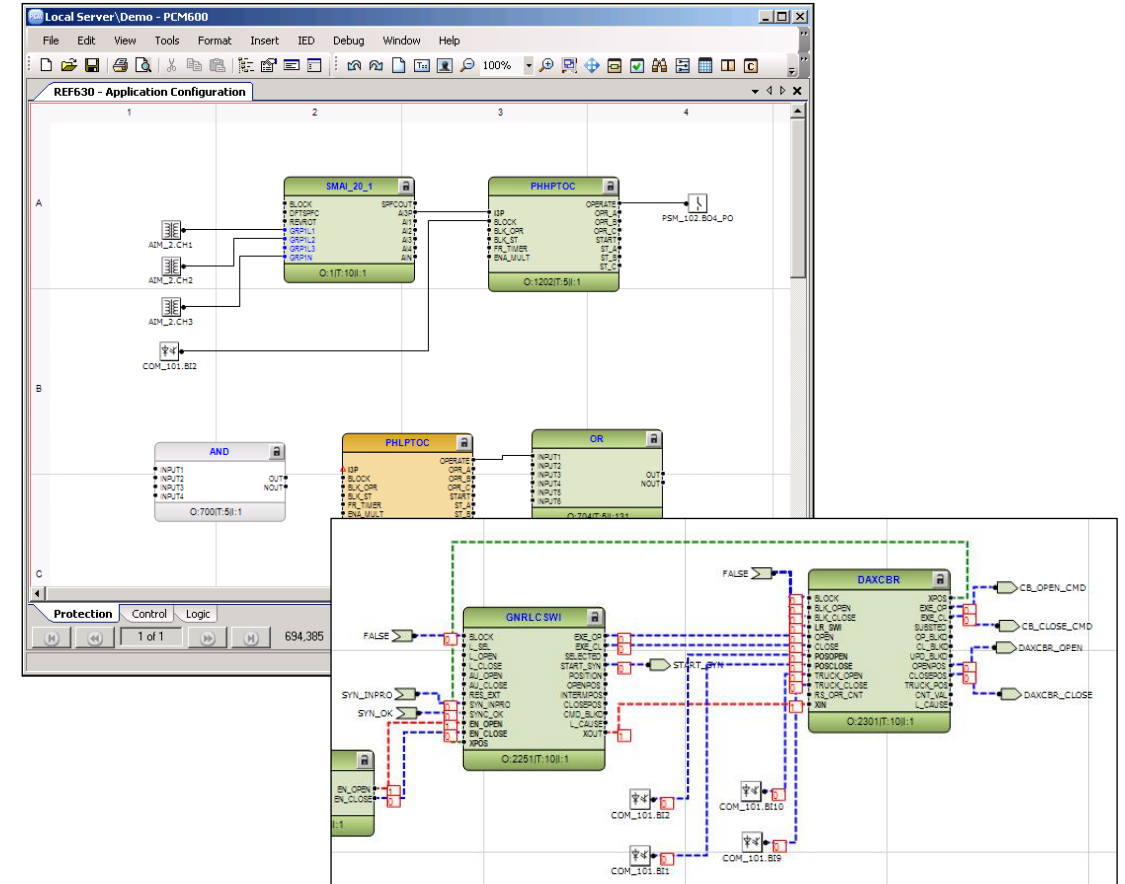

# Centralized protection and control features

## Simplification of assets



### Customer need

- Minimize the number of devices for reduced complexity
- Simplify spare device management
- Concentrate on 1-2 devices that fit all applications



### Solution

- Relion protection relays as universal devices with basic backup functions
- SSC600 as main protection with flexible high-end protection functionality
- Reuse of templates with small changes to the main configuration for different substations
- No need for additional gateway as IEC 60870-5-104 and DNP3 allow easy and direct connection to an upper-level system such as SCADA
- Number of protection device variants reduced when using:
  - SSC600 (one variant)
  - REX600 (one variant)

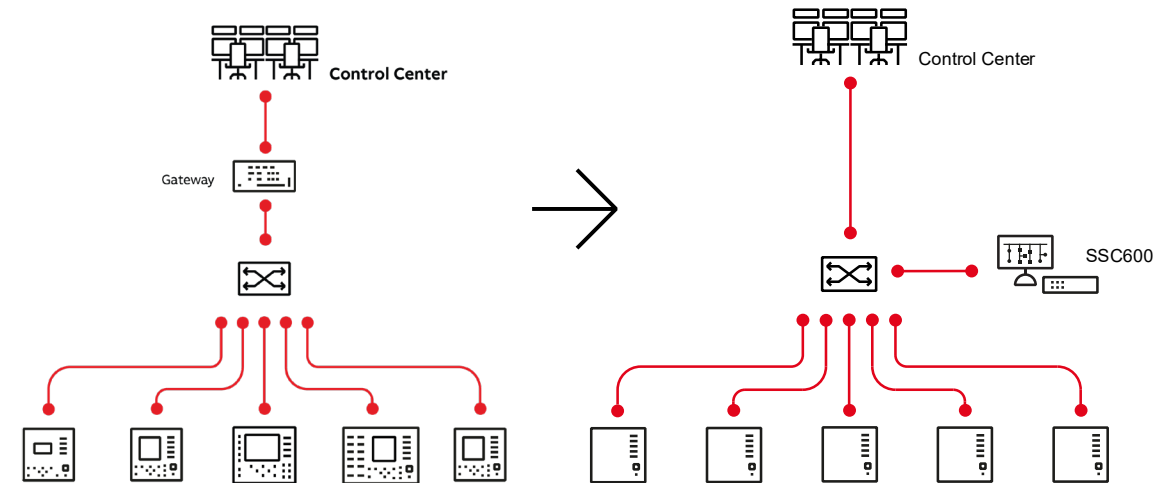

# Centralized protection and control features

## Virtualization of protection and control



### Customer need

Gain efficiency and flexibility with independent hardware and software



### Solution

Smart Substation Control and Protection SSC600 SW

- Use hardware of your choice
- Introduce new functionalities via adding software only
- Gain virtual machine technology benefits
- Get access to the latest features and functionalities with Software Maintenance Agreement (SMA)



**2** software images on one server



**2** centralized protection and control devices



**60** protection relays

# Centralized protection and control features

## Simplified project and engineering workflow



### Customer need

- Save time and money on system engineering
- Concentrate all engineering efforts on one product



### Solution

- PCM600 used for configuration, engineering and setting of SSC600
- Simplified workflow for bay-level protection and control functionality
- Reuse of templates with small changes to the main configuration for different substations

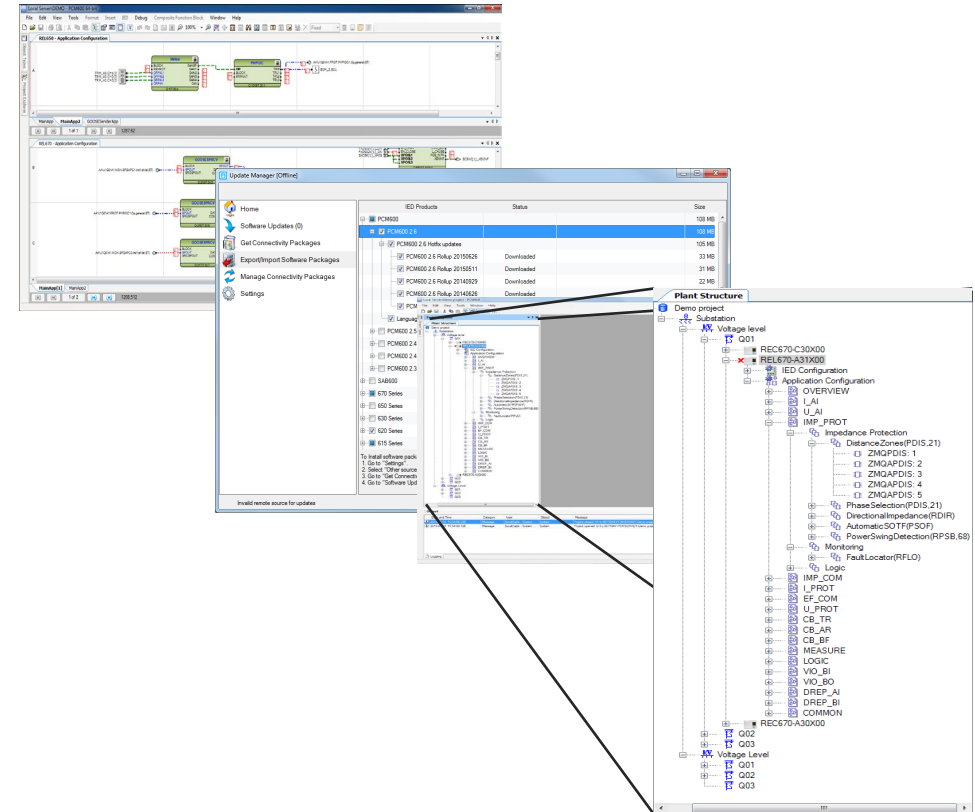

# Centralized protection and control features

## Interoperability



### Customer need

- Future-proof communication inside the substation
- Possibility to take advantage of features from the latest international standards
- Seamless integration of all IEC 61850-compliant devices in the substation and between substations



### Solution

SSC600 is based on international standards:

- IEC 61850-7 for modelling
- IEC 61850-8-1 (GOOSE and MMS) for control and reporting
- IEC 61850-9-2LE (SMV) for measurements
- IEC 61869-9 (SMV) for measurements
- IEEE 1588 v2 (Precision Time Protocol) for time synchronization
- IEC 61850-90-5 R-GOOSE and R-SV for substation-to-substation communication
- COMTRADE for fault analysis

MUs and remote I/O units can be any standard-compliant devices, even non-ABB products.

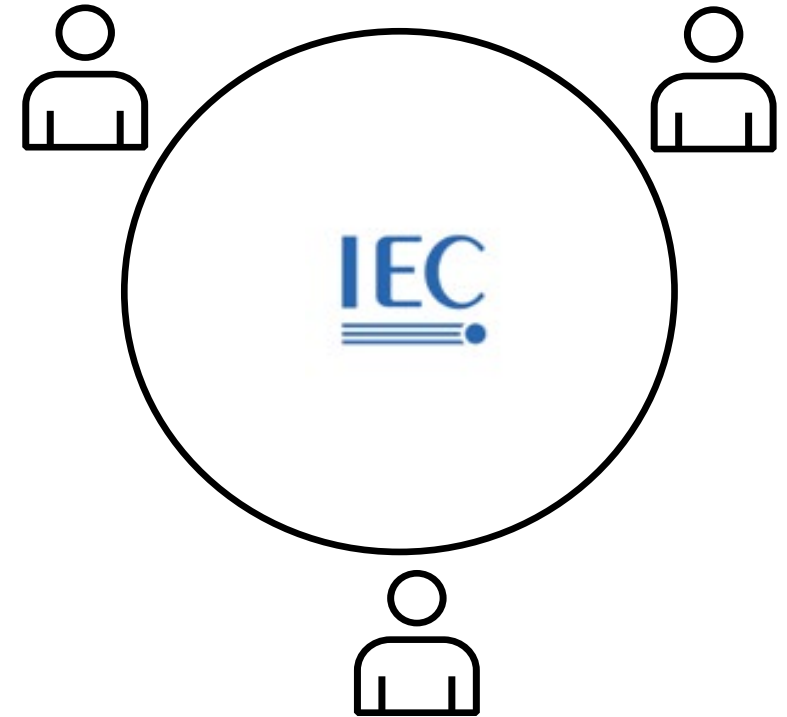

# Centralized protection and control features

## Support for digital substations



### Customer need

- Distribution applications with flexible multiapplication functionalities
- Reduced hardwiring
- Digital communication between substations



### Solution

- Existing IEC 61850 devices with sampled measured values (SMV) sending capabilities
- Support for ABB sensor technology with the Relion family of protection and control devices
- Substation-to-substation communication with routable GOOSE (R-GOOSE) and routable sampled values (R-SV)

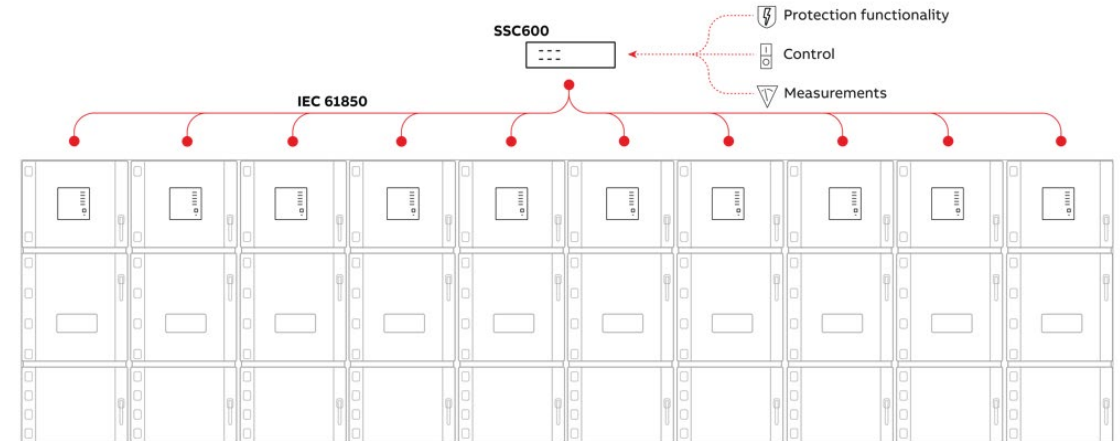

# Centralized protection and control features

## Simplified busbar protection



### Customer need

- Cost-efficient protection for busbar(s)
- Different choices for implementation of busbar protection
- Busbar protection without additional hardware



### Solution

On top of other substation protection, SSC600 can be used for busbar protection

#### Arc flash protection

- MUs sense the light whereas SSC600 has the logic for selective tripping
- Easy-to-manage and engineer system with multiple sensors

#### Busbar differential protection

- Based on the low-impedance differential principle
- No need for extra equipment in addition to SSC600 and MUs
- Up to 30 bays
- 4 protection zones and a check zone
- For single and double busbars

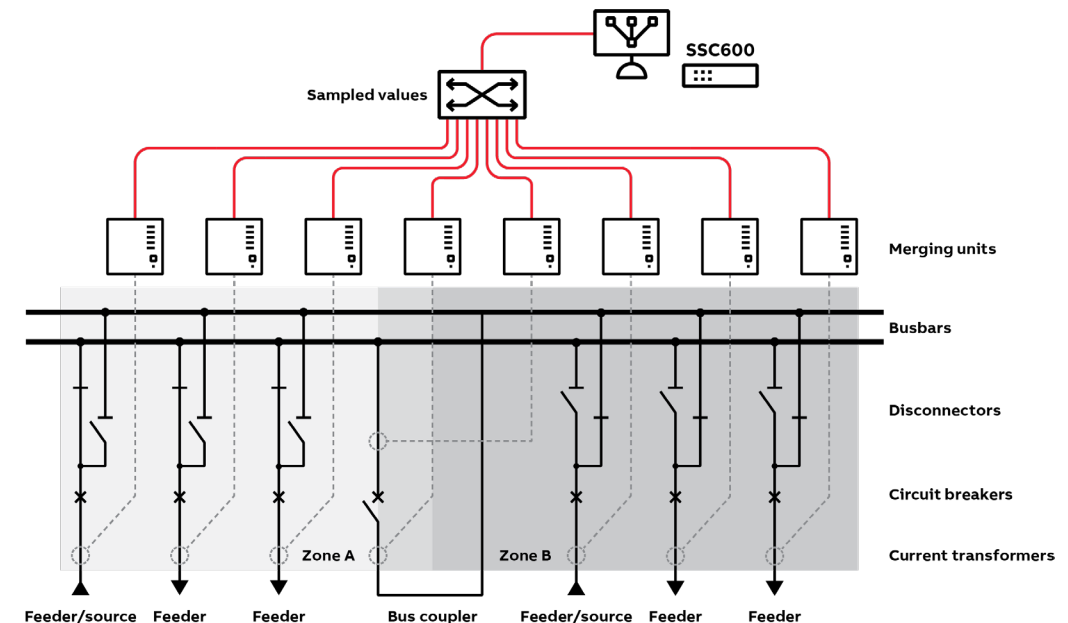

## Other product features

### Anomaly detector

- Monitor electrical grid to detect atypical events, which might lead to future issues
- Inputs are the same currents and voltages as used for protection
- Separate indication for each phase and residuals
- Just 2 settings
  - Window size
  - Sensitivity for each quantity
- Used to trigger events and recordings, which can be used in further analytics, such as fault prediction with AI

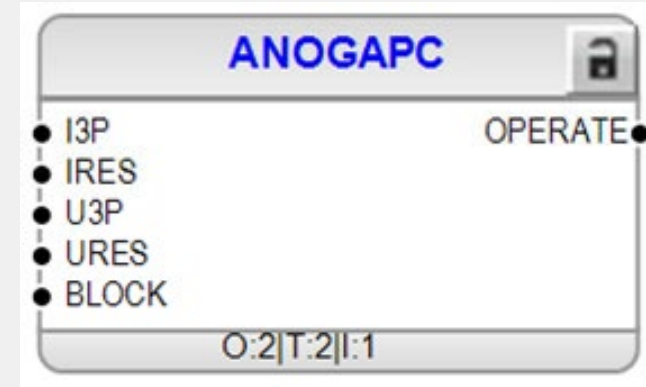

$$\text{anomaly indicator} = \sqrt{\sum_i^n (x_i - \tilde{x}_i)^2}$$

# Centralized protection and control features

## Line differential protection

- Line differential protection for full selectivity in feeder protection
- Supports in-zone transformer
- Up to 4 instances
- Protection communication according to IEC 61850
  - Analog values with IEC 61850-9-2LE or IEC 61869-9
  - Binary values and commands with GOOSE
  - Supports also routable protocols according to IEC 61850-90-5
- Two-ended (SSC600 in both ends) or standalone (one SSC600) modes
- Remote echo mode for supervision and testing
- Interoperable with any standard-compliant merging unit

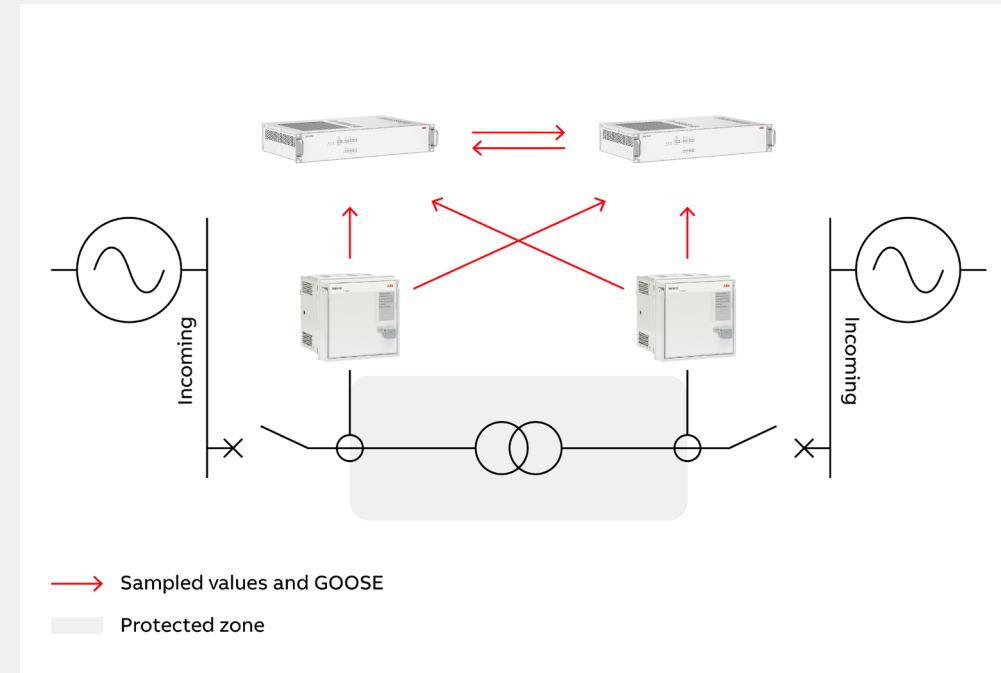
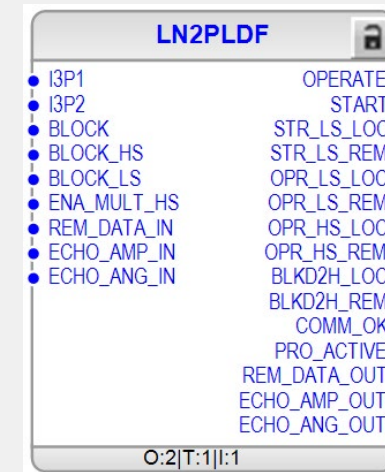

# Centralized protection and control features

## Cyber security



### Customer need

- Enhanced cyber security
- Defense in depth with segregated networks
- Secure firmware updates



### Solution

- Support for the evolving cyber security standards and regulations for critical infrastructure
- Support for separating process bus to a dedicated network interface
- Separate local interface for SLD control, engineering interface with DHCP and service interface with own IP address
- Closable network-capable ports
- Secure engineering communication with HTTPS and FTPS
- Rollback to previous version in case of firmware update error
- Role-based access control
- User-manageable device certificates

SSC600 - Parameter Setting					
Group / Parameter Name	IED Value	PC Value	Unit	Min	Max
✓ Communication: 0					
✓ Configuration					
✓ Rear port(s)					
✓ IP address	🔒	192.168.3.100			
✓ Subnet mask	🔒	255.255.255.0			
✓ Default gateway	🔒	192.168.2.1			
✓ Mac address	🔒	XX-XX-XX-XX-XX-XX			18 characters
✓ Local port					
✓ IP address	🔒	192.168.0.254			
✓ Mac address	🔒	XX-XX-XX-XX-XX-XX			18 characters
✓ Remote port					
✓ Enable	🔒	False			
✓ IP address	🔒	192.168.1.254			
✓ Mac address	🔒	XX-XX-XX-XX-XX-XX			18 characters
✓ Service port					
✓ Enable	🔒	False			
✓ IP address	🔒	192.168.3.10			16 characters
✓ Subnet mask	🔒	255.255.255.0			16 characters
✓ Mac address	🔒	XX-XX-XX-XX-XX-XX			18 characters

---

# Contents



**Introduction**



**Centralized protection and control features**



**Customer benefits**

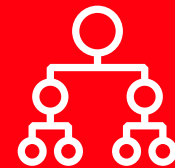

**Solution examples**

# Centralized protection and control features

## Redundancy of protection functionality via a hybrid installation



### Customer need

- Redundancy of protection and control functionality
- Selective and reliable backup protection



### Solution

- SSC600 added to existing installation as main protection, leaving existing relays and other protection devices as backup protection
- Redundant communication with PRP Time synchronization via the IEEE 1588 v2 GPS master or a relay acting as backup time master
- Substation gateway doubles up as HMI
- Combined or separated IEC 61850 network for the process and station bus
- Direct communication to the control center possible with IEC 61850, IEC 60870-5-104, or DNP3 without an external gateway in between

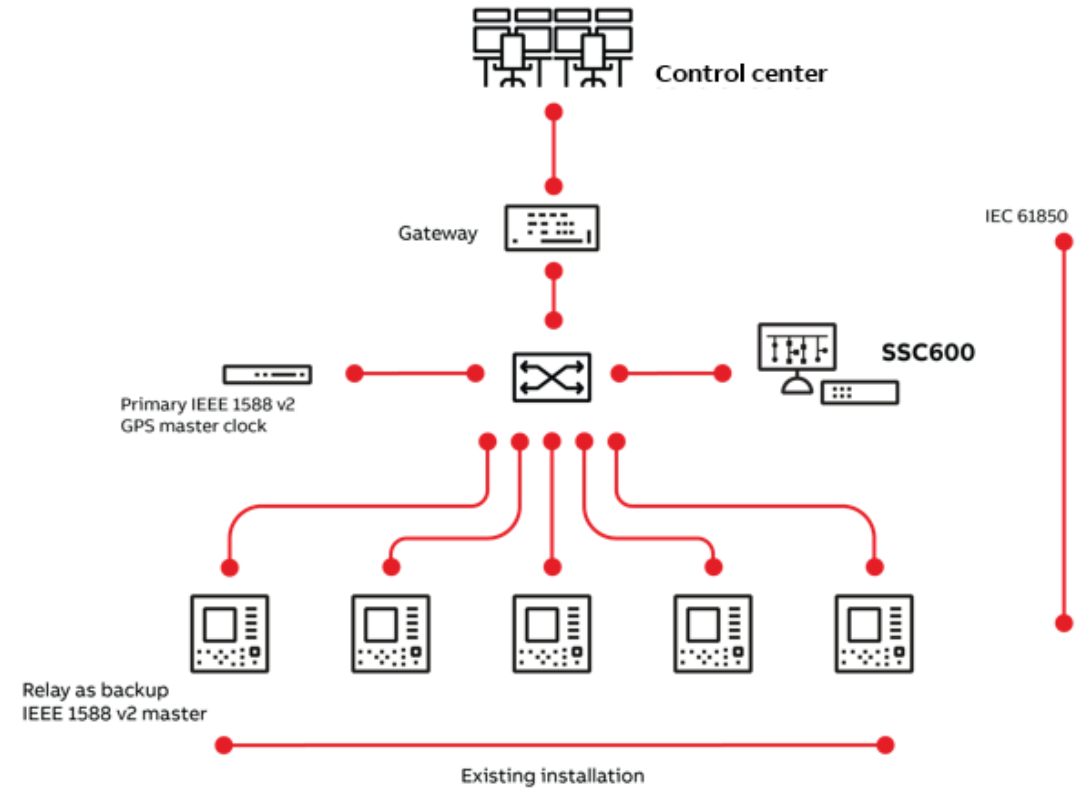

# Centralized protection and control features

Centralized protection and control with full redundancy



## Customer need

- Change to centralized protection with a redundant protection scheme
- Complete greenfield or retrofit installation



## Solution

Two SSC600 devices and one gateway to the SCADA system

- Redundant power supply in SSC600
- Both SSC600 devices in hot-hot redundancy mode
- Redundant communication with PRP
- Time synchronization via the IEEE 1588 v2 GPS master and backup time master from MU or secondary GPS master

Substation gateway doubles up as HMI

Combined or separated IEC 61850 network for the process and station bus

Direct communication to the control center possible with IEC 61850, IEC 60870-5-104, or DNP3, without an external gateway in between

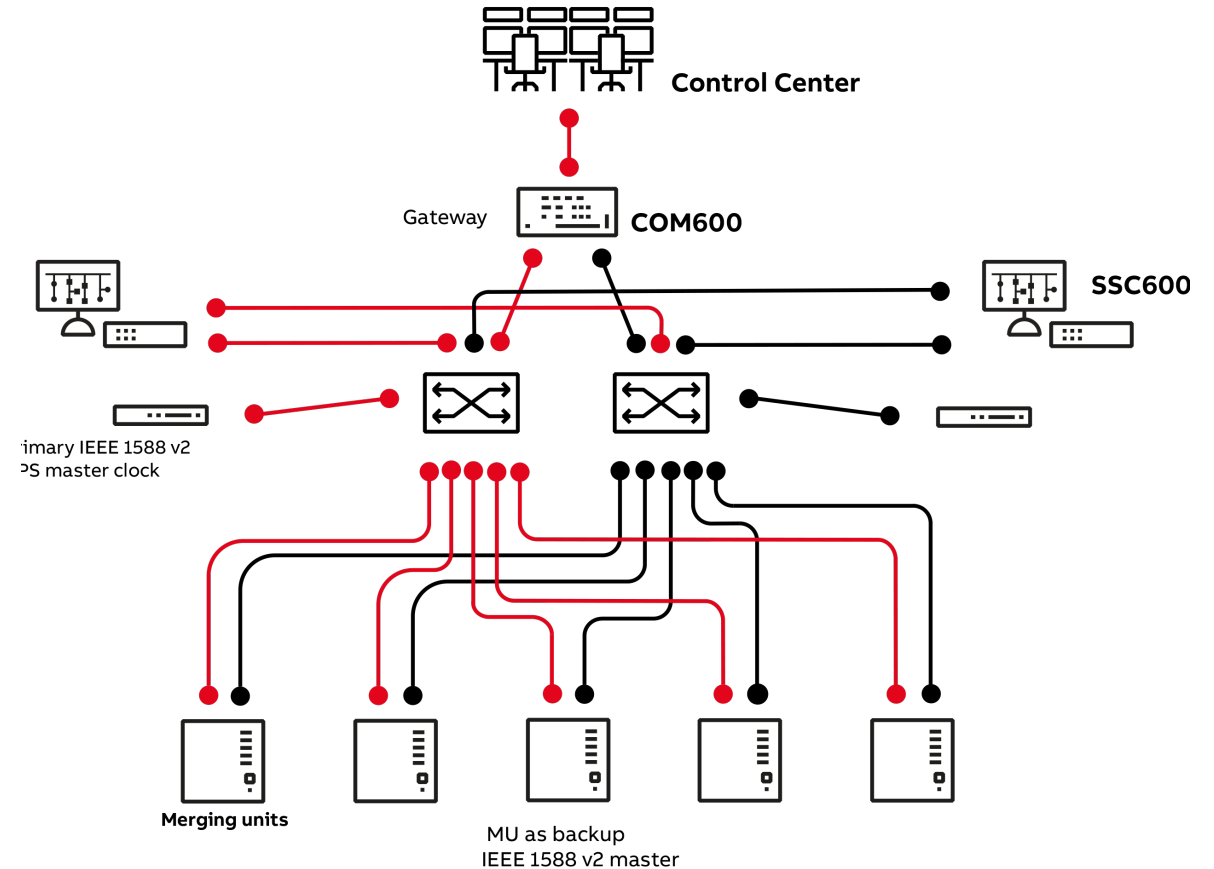

# Centralized protection and control features

## Centralized protection with backup trip unit



### Customer need

- Failsafe redundant backup trip signal in case of relay or MU failure



### Solution

SSC600 combined with IEC 61850-capable devices

- SSC600 as main protection with flexible applications
- REX600 or Relion® protection relay as backup protection
- Remote I/O unit RIO600 added to facilitate backup trip signaling to bay-level circuit breakers

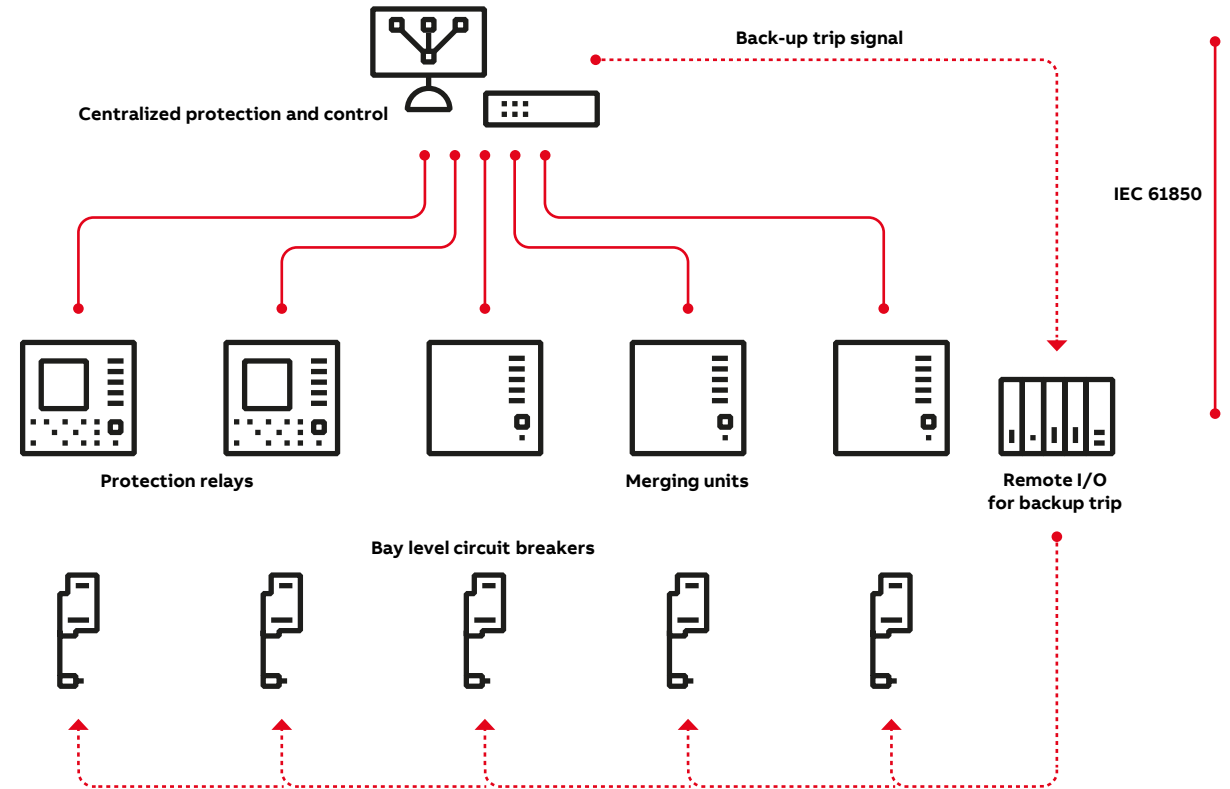

**ABB**