

NOTES:

1. WARNING: This drawing does not completely illustrate the installation methods required for hazardous locations. Prior to any installation in a Classified Hazardous Location, verify installation methods by the Control Drawing referenced on the product's name tag and national and local codes.

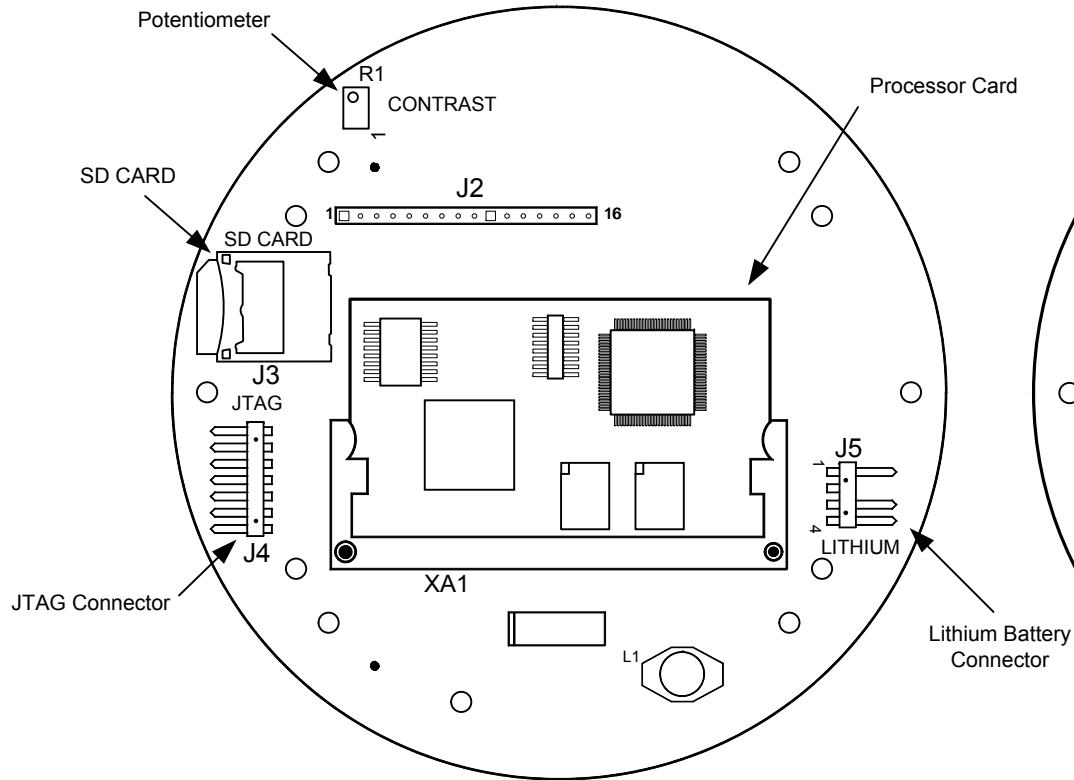

Motherboard
Primary Component Side

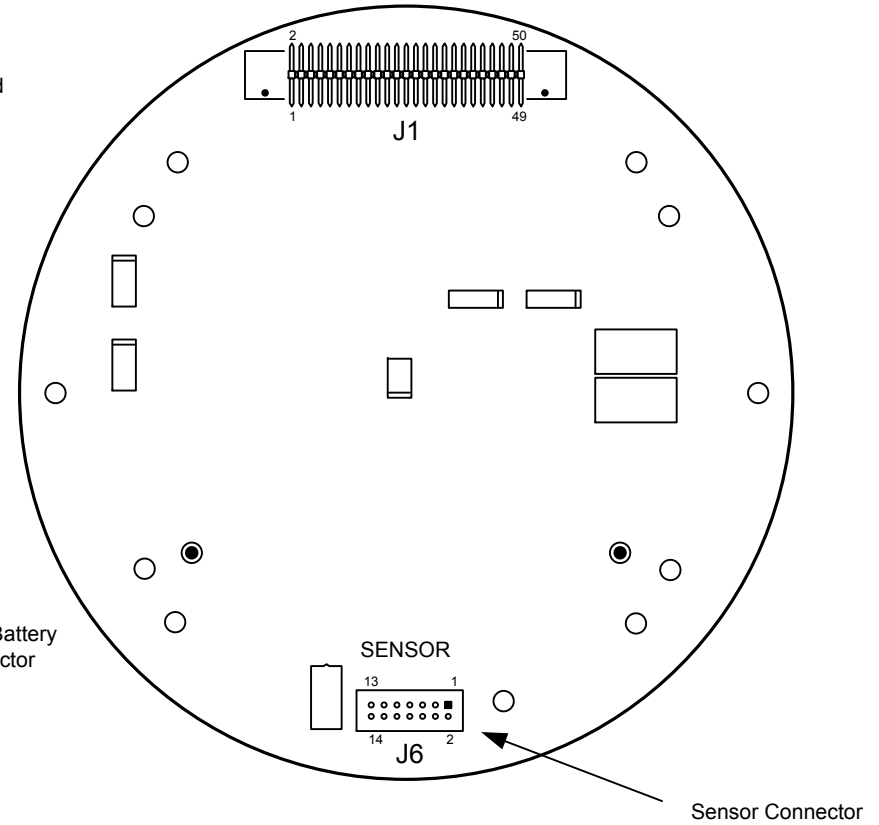

Motherboard
Secondary Component Side

REF: N/A

	TOTALFLOW	ACTION	DOC TYPE	TITLE	DWG NO.	REV	SHEET
	Products	L22126	UD	XFCG4EX CIRCUIT BOARD ELEMENTS	2104217	AA	1 OF 3

NOTES:

1. **WARNING:** This drawing does not completely illustrate the installation methods required for hazardous locations. Prior to any installation in a Classified Hazardous Location, verify installation methods by the Control Drawing referenced on the product's name tag and national and local codes.

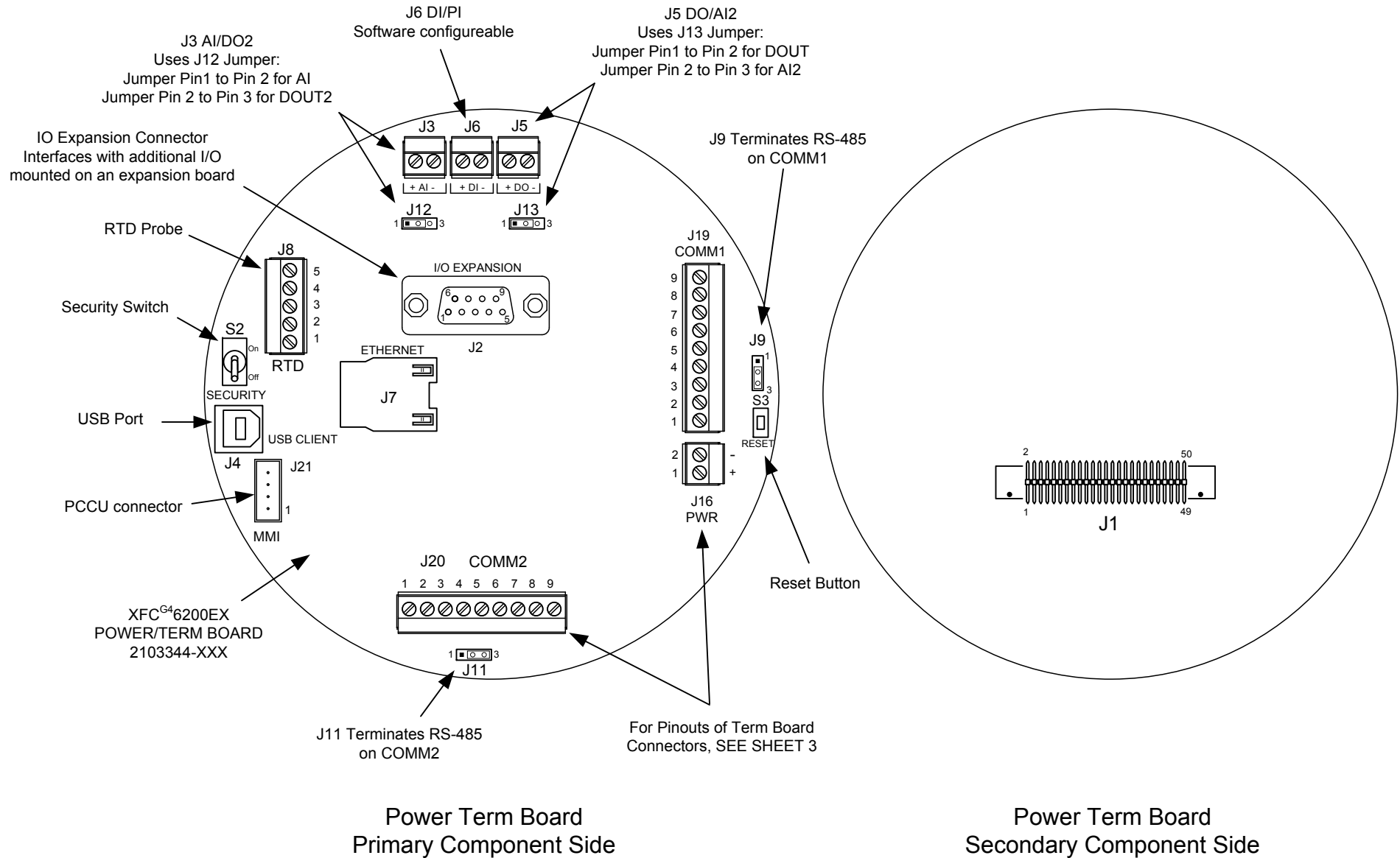

Power Term Board
Primary Component Side

Power Term Board
Secondary Component Side

ABB	TOTALFLOW	ACTION	DOC TYPE	TITLE	DWG NO.	REV	SHEET
	Products	L22126	UD	XFCG4EX CIRCUIT BOARD ELEMENTS	2104217	AA	2 OF 3

NOTES:

1. WARNING: This drawing does not completely illustrate the installation methods required for hazardous locations. Prior to any installation in a Classified Hazardous Location, verify installation methods by the Control Drawing referenced on the product's name tag and national and local codes.

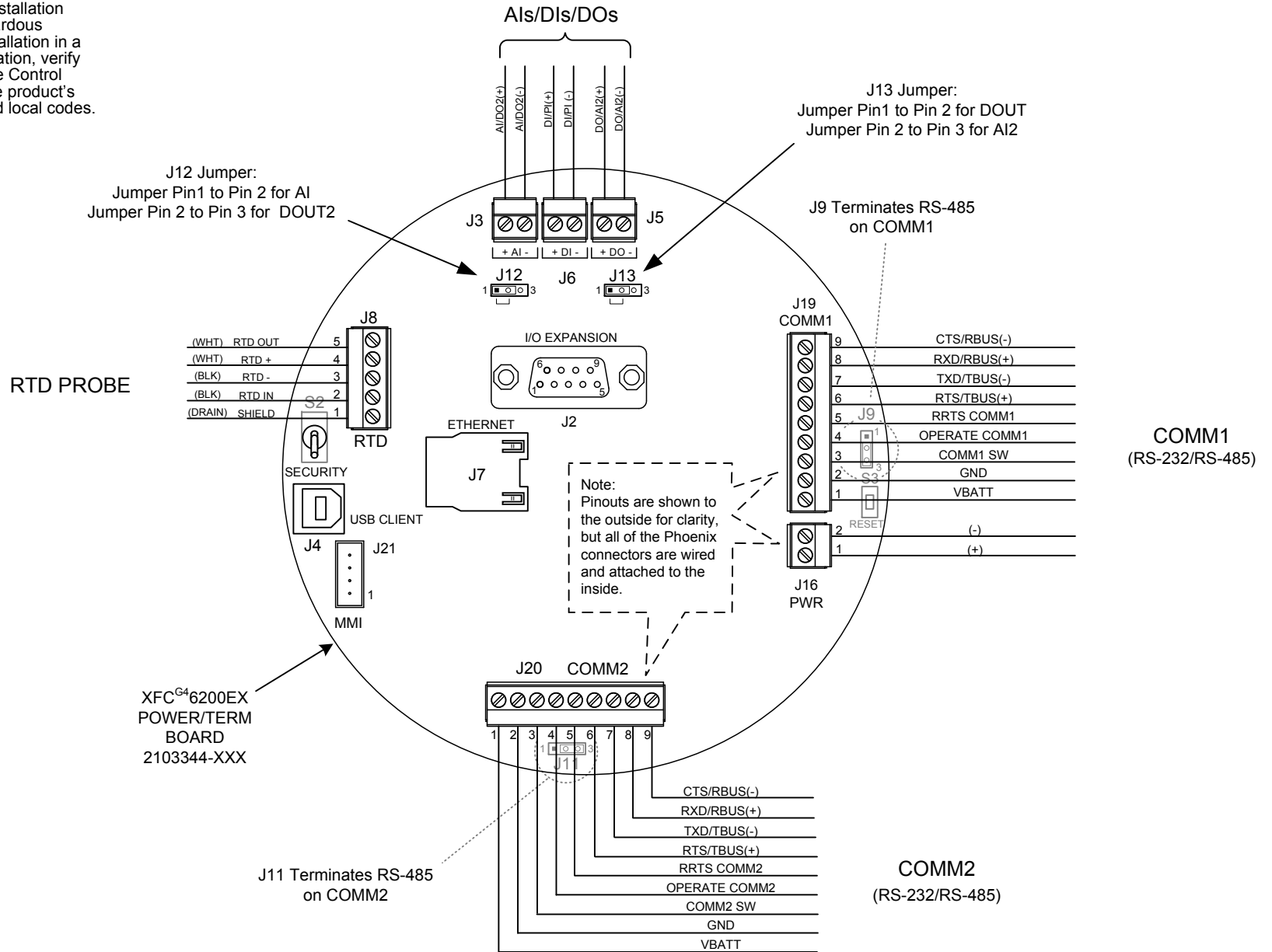

REF: N/A

	TOTALFLOW	ACTION	DOC TYPE	TITLE	DWG NO.	REV	SHEET
	Products	L22126	UD	XFCG4EX CIRCUIT BOARD ELEMENTS	2104217	AA	3 OF 3