

INSITE PRO M COMPACT

SCU100

User manual

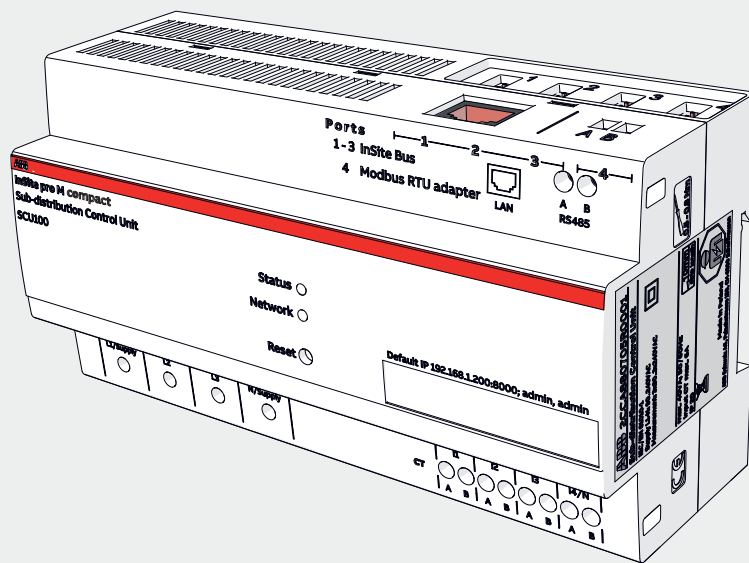

Table of Contents

1.General Information.....	5
1.1.Use and Storage of the manual	5
1.2.Cleaning.....	6
1.3.Installation to mains.....	6
1.4.Disconnection from mains or connections to mains.....	6
1.5.Safety warnings	6
1.6.Disposal	6
1.7.Service and maintenance	6
1.8.Cyber Security disclaimer.....	7
2.System overview	8
2.1.Sub-distribution Control Unit SCU100.....	8
2.2.Current sensors	10
2.3.I/O modules	12
2.4.Accessories	13
2.5.Current transformer	13
3.Packaging contents.....	15
3.1.Control unit.....	15
3.2.I/O modules	15
4.Technical characteristics / specifications	16
4.1.Overall dimensions and technical data sub-distribution control unit.....	16
4.2.Overall dimensions and technical data I/O modules.....	17
4.3.Compatible devices	18
5.Main functionalities and measurements	19
5.1.Measurements	19
5.2.Memory architecture.....	20
6.Installation	21
6.1.Control Unit	21
6.2.Assembly of connectors, current sensors and I/O modules.....	22
6.3.Meters connection.....	26
7.Wiring diagram.....	27
7.1.Control unit	27
8.Access to control unit	30
8.1.Network connection	30
8.2.Control unit login	34

9.Web User Interface	35
9.1.Structure	35
10.Web UI - Configuration.....	36
10.1.Devices	36
10.2.Modbus TCP Slaves	46
10.3.Modbus RTU Devices.....	48
10.4.Groups.....	50
10.5.Tree view	51
10.6.Alarms	53
10.7.Automation.....	54
10.8.Export/Import.....	55
11.WebUI - Settings	56
11.1.Users.....	56
11.2.Email - FTP	57
11.3.Communication	58
11.4.SSL certificate.....	68
11.5.General.....	69
12.WebUI – Monitor	72
12.1.Dashboard	72
12.2.Real-time values	74
13.WebUI – Analytics.....	77
13.1.Historical values.....	77
13.2.Benchmark.....	78
13.3.Alarms log.....	78
13.4.Data export	79
14.WebUI – Control.....	80
14.1.Control	80
15.Modbus TCP/RTU communication interface	81
15.1.Control unit mains and sensors readings.....	81
15.2.Meters	87
15.3.I/O modules	88
15.4. External Modbus alarm registers for IOM	89
16.Simple Network Management Protocol – SNMP	90
16.1.SNMP objects	92

1. General Information

This manual contains all the safety information, the technical aspects and the operating necessary to ensure the correct use of the device and maintain it in safe conditions.

1.1. Use and Storage of the manual

Storing

The manual must be stored close to the device; safe from liquids and anything else which may compromise its legibility. The manual and the declaration of conformity are both an integral part of the device until it is dismantled. If the manual is lost or illegible please request a copy from the manufacturer.

Copyright

The copyright of this manual is the property of ABB Ltd. This manual contains texts, designs and illustrations of a technical nature which must not be disclosed or transmitted to third parties, even partially, without the written authorisation of ABB Ltd.









Liability disclaimer

The information contained in this document is subject to change without notice and cannot be considered as an obligation by ABB Ltd. ABB Ltd. is not liable for any errors that may appear in this document. ABB Ltd. is not liable under any circumstances for any direct, indirect, special, incidental or consequential damage of any kind that may arise from using this document. ABB Ltd. is also not liable for incidental or consequential damage that may arise from using the software or hardware mentioned in this document.

Brand

ABB Ltd. is a registered trademark of ABB Group. All other brands or product names mentioned in this document are trademarks or registered trademarks of their respective owners.

Meaning of symbols

	Warning – can result in death or serious personal injury		Non-safety related, but useful and important information
	CE conformity mark		Torque
	Observe the accompanying documents		Disposal
	Installation, electrotechnical expertise		Equipment protected throughout by reinforced insulation

1.2.Cleaning

Use a dry cloth.

1.3.Installation to mains

Installation of device to mains shall include a switch or circuit breaker for the connection to mains. The switch or circuit breaker must be suitably located and easily reachable and must be marked as the disconnecting device for the device.

1.4.Disconnection from mains or connections to mains

Switch off circuit breaker or switch before disconnecting from the mains supply or connecting to the mains supply. Same applies for all other connections (L1, L2, L3, N).

1.5.Safety warnings



Attention: Non-adherence to the following points can lead to serious injury or death. Use the suitable personal protection devices and adhere to the current regulations governing electrical safety.

This device must be installed exclusively by qualified personnel who have read all of the information relative to the installation.

Check that the voltage on the main side is compatible with the range permitted by the device.

Ensure that all current and voltage supplies are disconnected prior to carrying out any controls, visual inspections and tests on the device.

Always assume that all circuits are under voltage until they are completely disconnected, subjected to tests and labelled.

Disconnect all of the power supply prior to working on the device.

Always use a suitable voltage detection device to check that the supply is interrupted.

Pay attention to any dangers and carefully check the work area ensuring that no instruments or foreign objects have been left inside the compartment in which the device is housed.

The correct use of this device depends on a correct manipulation, installation and use.

Failure to adhere to the basic installation information can lead to injuries as well as damage to the electric instruments or to any other product.

The tests carried out at a high voltage can damage the device's electronic components.

1.6.Disposal



Defective devices must be disposed of as special waste at the appropriate collection points set up for this purpose. National or regional regulations on the disposal of special waste must be followed.

1.7.Service and maintenance

The device undergoes several safety assessments before shipment and will be sealed. If a device is opened, the safety assessments have to be repeated. A warranty will be provided for unopened devices only.

1.8.Cyber Security disclaimer

Sub-distribution Control Unit SCU100 is designed to be connected and to communicate information and data via a network interface, which should be connected to a secure network. It is your sole responsibility to provide and continuously ensure a secure connection between the product and your network or any other network (as the case may be) and to establish and maintain appropriate measures (such as but not limited to the installation of firewalls, application of authentication measures, encryption of data, installation of antivirus programs, etc.) to protect the Sub-distribution Control Unit SCU100 product, the network, its system and interfaces against any kind of security breaches, unauthorized access, interference, intrusion, leakage and/or theft of data or information. ABB S.p.A. and its affiliates are not liable for damages and/ or losses related to such security breaches, unauthorized access, interference, intrusion, leakage and/or theft of data or information.

Although ABB S.p.A. provides functionality testing on the products and updates that we release, you should institute your own testing program for any product updates or other major system updates (to include but not limited to code changes, configuration file changes, third party software updates or patches, hardware change out, etc.) to ensure that the security measures that you have implemented have not been compromised and system functionality in your environment is as expected.

2. System overview

InSite pro M compact is a monitoring system which brings complete overview of the system performances and enables energy and asset management.

The system consists of a Sub-distribution Control Unit (SCU100) and field devices connected to the control unit: energy and power meters, current sensors, digital input and output modules (I/O modules).

The input measurements and data from meters are transmitted via Modbus RTU communication protocol. The input measurements and information from current sensors and I/O modules are transmitted through a flat cable, the InSite bus. All gathered data can be displayed or analyzed via LAN interface with the integrated web server or Modbus TCP or SNMP protocols or via RS485 interface, such as Modbus RTU.

2.1. Sub-distribution Control Unit SCU100

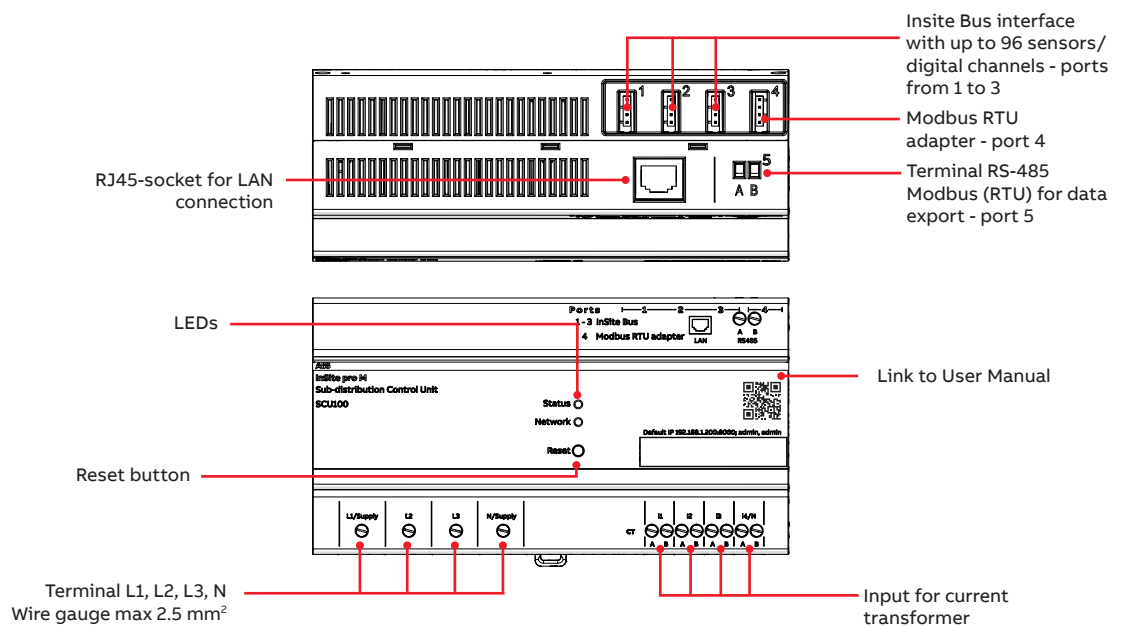

Reset button

There is a recessed button to restart the device or for resetting it to factory settings.

- Pressing the button for 3 to less than 6 seconds restarts the device with current settings
- Pressing the button for more than 10 seconds resets the device to the factory settings

Do not switch off the device during the reset process.

LEDs

Two LEDs indicate respectively the status of the device and the one of the network.

• LED Status

Display	Function
Off	Device is off
Green on	Device is ready
Green flashing slowly	Firmware is ready, Web server is loading
Orange flashing slowly	Firmware update ongoing
Orange on	Booting
Red on	Booting error

• LED Network

Display	Function
Off	LAN is not connected
Green on	LAN is connected
Green flashing	Network traffic



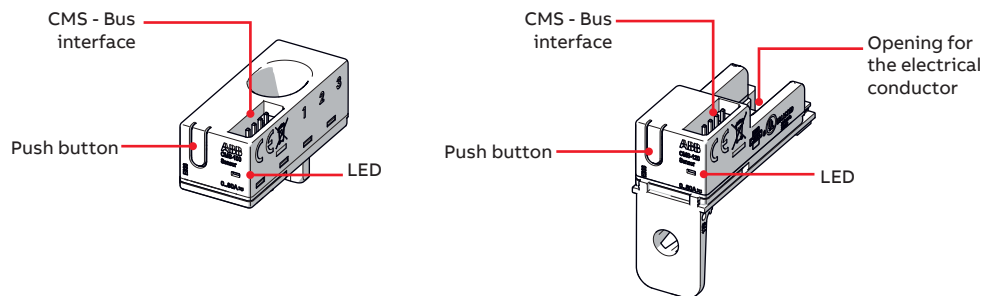

2.2. Current sensors



• Current sensors LED Status

Display	Function
On	Sensor is online and in measurement mode. There is a feature in the configuration to switch off the LED of all the sensors after a specified time.
Off	Sensor is not connected to InSite Bus or LED is switched off in the configuration. Sensor is not assigned.
	Sensor in assign process or in “setting/branches” mode. This sensor is the sensor corresponding to the yellow-marked row on the screen for webserver settings.
	Flashing slowly (1Hz)
	Flashing fast (2Hz)

Sensors overview

	System Pro M, SMISLINE	S800	DIN rail	Cable tie		
						
Mounting method	for all MCBs, RCDs, RCBOs with twin terminals	for MCBs (S200, SMISLINE) and RCBOs (SMISLINE)	for fuse holders E90 (1000VDC)	for all S800 devices with cage terminals	universally usable	universally usable

Open-core sensors

AC accuracy* of $\leq \pm 1.0\%$

The laying method influences the accuracy.

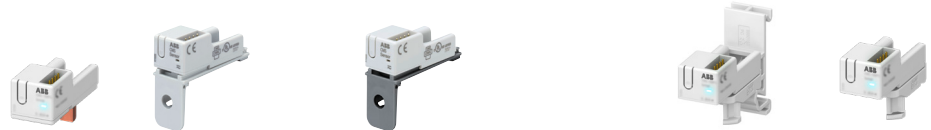

18-mm overall width

CMS-120xx (80 A)	CMS-120PS	CMS-120LA	-	CMS-120DR	CMS-120CA
CMS-121xx (40 A)	CMS-121PS	CMS-121LA	CMS-121FH	CMS-121DR	CMS-121CA
CMS-122xx (20 A)	CMS-122PS	CMS-122LA	CMS-122FH	CMS-122DR	CMS-122CA

Solid-core sensors

AC accuracy* of $\leq \pm 0.5\%$



18-mm overall width

CMS-100xx (80 A)	CMS-100PS		CMS-100S8	CMS-100DR	CMS-100CA
CMS-101xx (40 A)	CMS-101PS		CMS-101S8	CMS-101DR	CMS-101CA
CMS-102xx (20 A)	CMS-102PS		CMS-102S8	CMS-102DR	CMS-102CA

25-mm overall width



CMS-200xx (160 A)			CMS-200S8	CMS-200DR	CMS-200CA
CMS-201xx (80 A)			CMS-201S8	CMS-201DR	CMS-201CA
CMS-202xx (40 A)			CMS-202S8	CMS-202DR	CMS-202CA

* All accuracy specifications refer to the relevant full scale value and apply to 25°C

2.3.I/O modules

The range of I/O modules is composed of:

- Input Module with 4 inputs
- Output Module with 4 outputs
- Input and Output Module with 2 inputs and 2 outputs

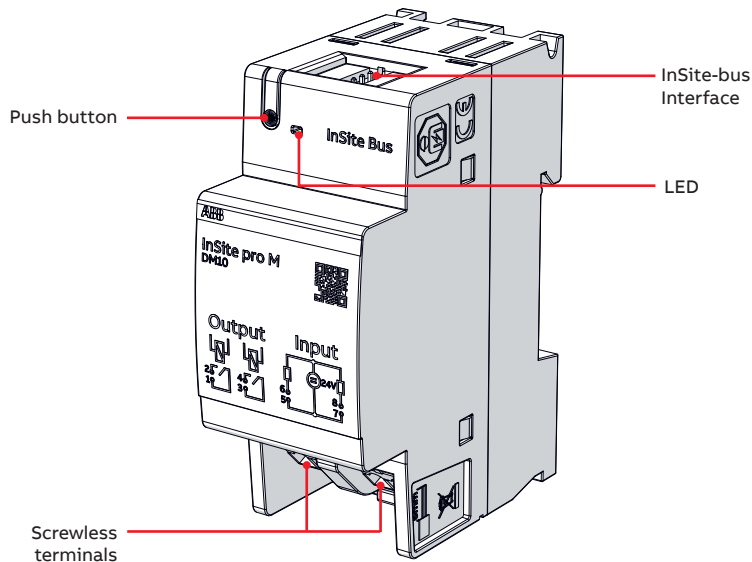

• Module LED Status:

Display	Function
On	Module is online and in normal operation mode. There is a feature in the configuration to switch off the LED after a specified time.
Off	Module is not connected to InSite Bus or LED is switched off in the configuration. Module is not assigned.
	Module in assign process or in “setting/I/O module” mode. This module is the module corresponding to the yellow-marked row on the screen for webserver configuration.
	Flashing slowly (1Hz)
	Flashing fast (2Hz)

2.4. Accessories

Modbus RTU Adapter

The Modbus RTU Adapter enables a simple connection from the 4th port of the SCU100 to the external ABB energy and power meters.



Only meters equipped with Modbus RTU communication can be connected.

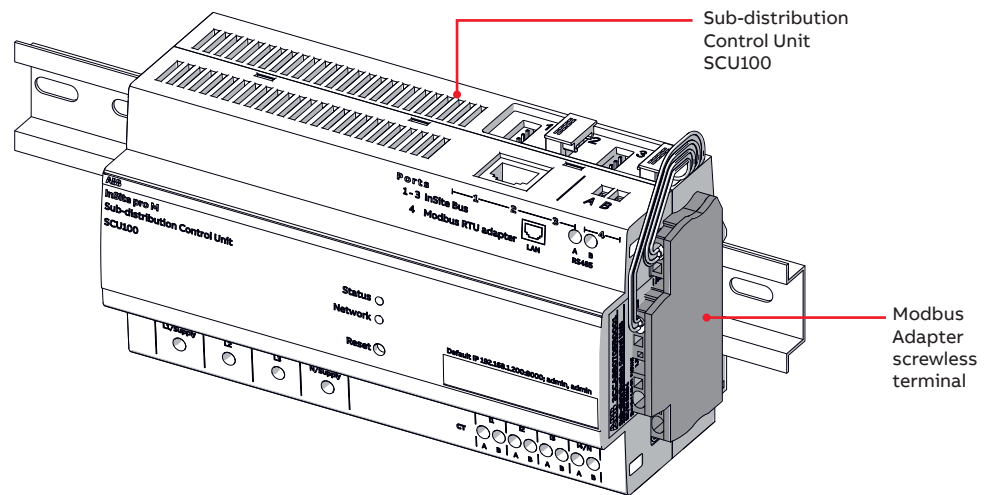

2.5. Current transformer

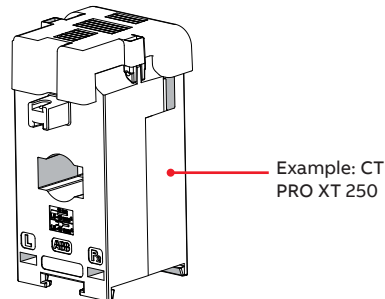

To measure current of mains (IMAINS) a current transformer is needed to transform the primary to $x/5A$ secondary currents

InSite Flat Cable

The INS105 flat cable is a 4-pin cable for connecting multiple sensors and I/O modules to one control unit.

Please take into account that possible cable length of the InSite flat cable depends on the number and shape of sensors, and on the number of I/O modules connected.

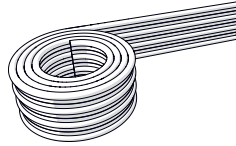

- Do not exceed a total flat cable length of 32m for each InSite-Bus lines of each control unit.
- Flat cables longer than approx. 15m could require a 120Ω terminating resistor between the two inner wires at the far end.
- For the flat cable, please consider:
- Use within closed housings only
- Keep a distance of min. 5.5 mm to uninsulated live parts
- Where necessary, additional protection against mechanical stress or UV radiation must be ensured.
- Interactive guide for calculation of maximum cable length under consideration of devices placement is available as a separate tool, available at link at pag. 22.

Connector set

The INS135 connector set contains connector housings and connectors to connect the flat cable to the sensors.

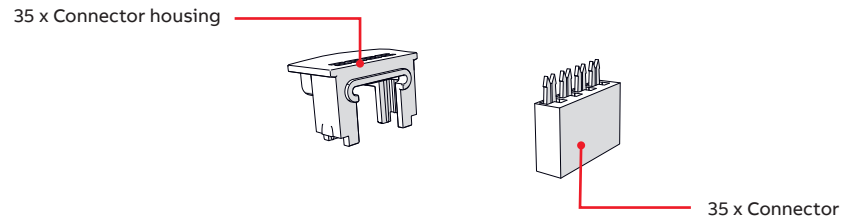

3.Packaging contents

3.1.Control unit

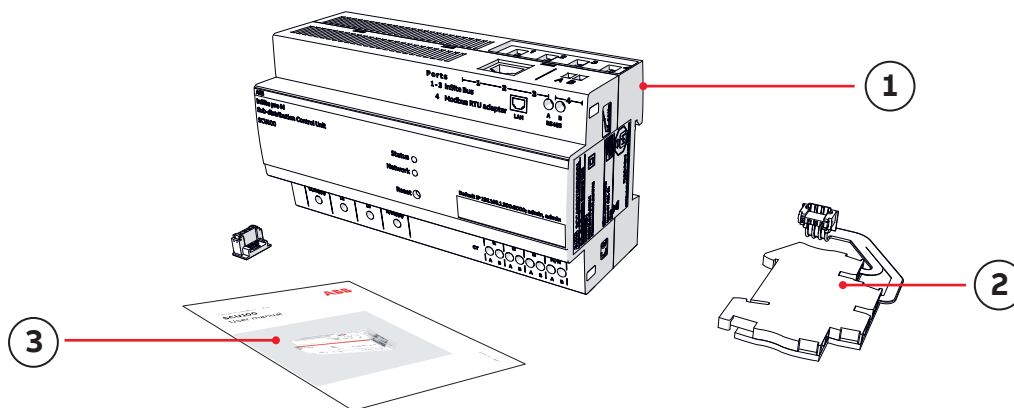

Packaging contents	
1	Sub-distribution Control Unit SCU100
2	Modbus RTU Adapter: includes the device to be mounted on the right side of the control unit + segment of flat cable + connector
3	Installation manual

The following items are not included in the delivery product:



- Current sensors
- I/O modules
- Current transformer (CT)
- InSite bus
- Connectors set

3.2.I/O modules

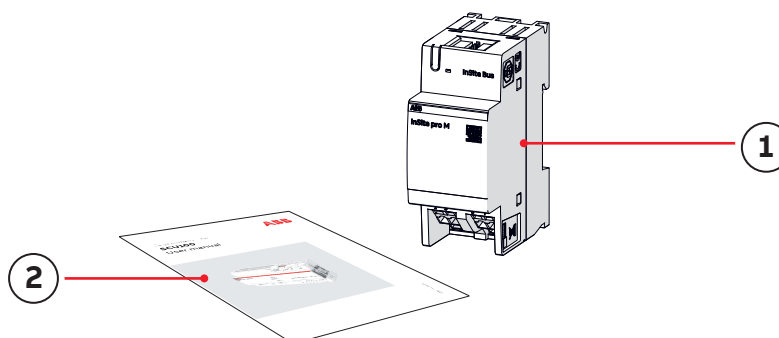

Packaging contents	
1	Digital module (Input, Output, Input/Output)
2	Installation manual

4. Technical characteristics / specifications

4.1. Overall dimensions and technical data sub-distribution control unit

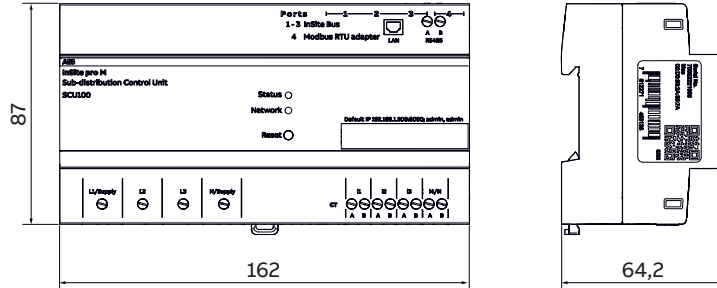

IEC61010-1		
Supply voltage	[VAC]	90-240 (L1-N)
Voltage measurement range	[VAC]	90-240 (L1-N, L2-N, L3-N)
UL 508 / CSA C22.2 No. 14		
Supply voltage	[VAC]	80-277 (L1-N)
Voltage measurement range	[VAC]	80-277 (L1-N, L2-N, L3-N)
General		
Frequency	[Hz]	50 / 60
Power consumption (L1-N)	[VA]	5 .. 45 (depending on number of sensors and I/O modules)
Current measurement range		
Current transformer (secondary wire of CT)	[A]	nominal: 5 max.: 6
Data refresh time		1sec / 30 sec (depending on type of data)
Operating temperature	[°C]	-25 .. +60
Storage temperature	[°C]	-40 .. +85
LAN (RJ45 connector)	[Mbit/s]	100
Modbus RTU	[Baud]	RS485 2-wire, 2400..115200
Cable cross section*		1.0.. 2.5 mm ² (max. 0.8 Nm)
Stripping length	[mm]	10
Tightening torque of screws	[Nm]	0.5..0.8
Mounting DIN-rail		35 mm DIN50022
Dimensions	[mm]	160.0 x 87.0 x 64.9 (9 DIN modules)
Overvoltage category		II
Pollution degree		2
Altitude	[m]	2000
Safety class		IP20
Main circuit accuracy		
Voltage		± 1 %
Current		± 1 %
Harmonic component (up to 2500Hz)		± 1 %
Active power		± 2 %
Apparent power		± 2 %
Reactive power		± 2 %
Power factor		± 2 %
Standards		
Electrical safety		IEC 61010-1
EMC		IEC 61326-1

*Line protection is recommended (acc. IEC61439) min. 6A, max 8A for 1mm², 12A for 1.5mm², 20A for 2.5mm².



Do not operate the equipment outside the specified technical data and not intended use.

4.2. Overall dimensions and technical data I/O modules

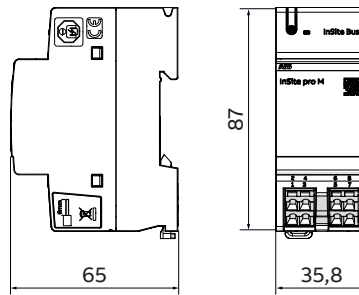

	Input module DM11	Output module DM00	Input and Output module DM10
Number of digital channels	4 Input	4 Output	2 Input + 2 Output
Voltage*	active input: 22-26 VDC	relay output: 24VDC-240 VAC	active input: 22-26 VDC relay output: 24VDC-240 VAC
Current*	active input: 4mA	relay output: 5mA-2.5A Max 4.5A (<5sec)	active input: 4mA Relay output: 5mA-2.5A Max 4.5A (<5sec)
Pulse minimum duration** [ms]	5	n/a	5
Pulse frequency** [Hz]	100	n/a	100
Screwless terminals cross section [mm ²]	0,08...2,5	0,08...2,5	0,08...2,5
Using ferrules [mm ²]	0,25...1,5	0,25...1,5	0,25...1,5
Stripping length [mm]	5 ... 6	5 ... 6	5 ... 6
Operating temperature [°C]			-25...+60
Bearing temperature [°C]			-40...+85
Mounting method	35 mm DIN rail (DIN 50022) or SMISSLINE TP plug base		
Dimensions [mm]	36x88x65	36x88x65	36x88x65
Overvoltage category			II acc. to (IEC61010-1)
Pollution degree			2
Altitude m			2000
Safety class			IP20
IK code			IK06(1J)
Standards compliance			IEC 61010
EMC			IEC 61326-1

*relay output values reported are applicable to resistive load

**applicable only to active inputs



Every active input is protect by 400V silicon diodes with fuse resistor against misunderstanding in connections like connecting 230Vac mains instead relays/transistor output of meter.



There is one fuse per 2 active input channels.



Do not operate the equipment outside the specified technical data and not intended use.

4.3. Compatible devices

Devices compatible with I/O Modules include Molded Case Circuit Breakers (MCCBs), accessories of DIN-Rail protection devices, overvoltage Protection devices and meters pulse output.

ABB ranges compatible with I/O Modules are:

Molded Case Circuit Breaker	
Tmax XT	
Miniature Circuit Breakers	Residual Current Devices
S 200	RCCBs – F 200
SN 201	RCD-blocks – DDA 200, DDA 800
S200 80-100A	RCBOs – DS 201, DS 202, DS 203, DS 200, DS800
S 750 DR	eRCBOs – DSE, DSN
S 700	
S 800	

I/O modules allow to:

- read contacts status of MCCBs via input channels
- read contacts status of OVRs with integrated auxiliary contact via input channels
- to read contacts status of accessories for Miniature Circuit Breakers (MCBs) and Residual Current Devices (RCDs) via input channels
- to switch accessories for Miniature Circuit Breakers (MCBs) and Residual Current Devices (RCDs) via output channels
- to switch contactors via output channels

Some examples of ABB accessories are:

- Signal/Auxiliary contact (S2C-S/H6R)
- Shunt trip for S 200 MCB (S2C-A...)
- Motor operating device (S2C-CM...)



Generally, all devices equipped with a digital output or input with technical characteristics compatible with table 4.3 can be connected in the system.

5. Main functionalities and measurements

5.1. Measurements

Measurements in the system are given by connected devices and the SCU100 control unit itself.

The principle of measurement for AC of the SCU100 control unit includes measurement on the mains and branches. On the mains side, all values are measured directly. On the branches, current is measured by the sensors while voltage, power factor as well as active power and energy are calculated using measured mains values.

For further information, please refer to the following table.

Mains	Branches/Sensors
Measurement of	
I_{MAINS} (Current) [A]	$I_{\text{TRMS}}, I_{\text{AC}}, I_{\text{DC}}$ (Current TRMS, AC, DC) [A]
Measured mains values used for calculation	
U_{MAINS} (Voltage) [V]	U_{MAINS} (Voltage) [V]
PF (Power Factor)	PF (Power Factor) (manual configuration is possible)
THD (Voltage, Current) (%)	
Calculation of	
Power:	
– active [W]	P_{SENS} (Active power) [W]
– apparent [VA]	$P_{\text{SENS}} = U_{\text{MAINS}} \cdot I_{\text{AC}} \cdot \text{PF}$
– reactive [var]	
Energy [kWh]	Energy _{SENS} [kWh]

With respect to I/O modules, collected and calculated data is reported in the following table.

I/O Modules	
Data received	Calculation of
Channel contacts status	
Change of channel contacts status	Number of changes of contacts status (counter)
Pulses	Summed quantities from meters pulse output



Attention: Referring to the diagram in the figure aside, please note that N on the supply has to be connected in order to avoid damage of the device. Twisting the phase and neutral can damage the device.

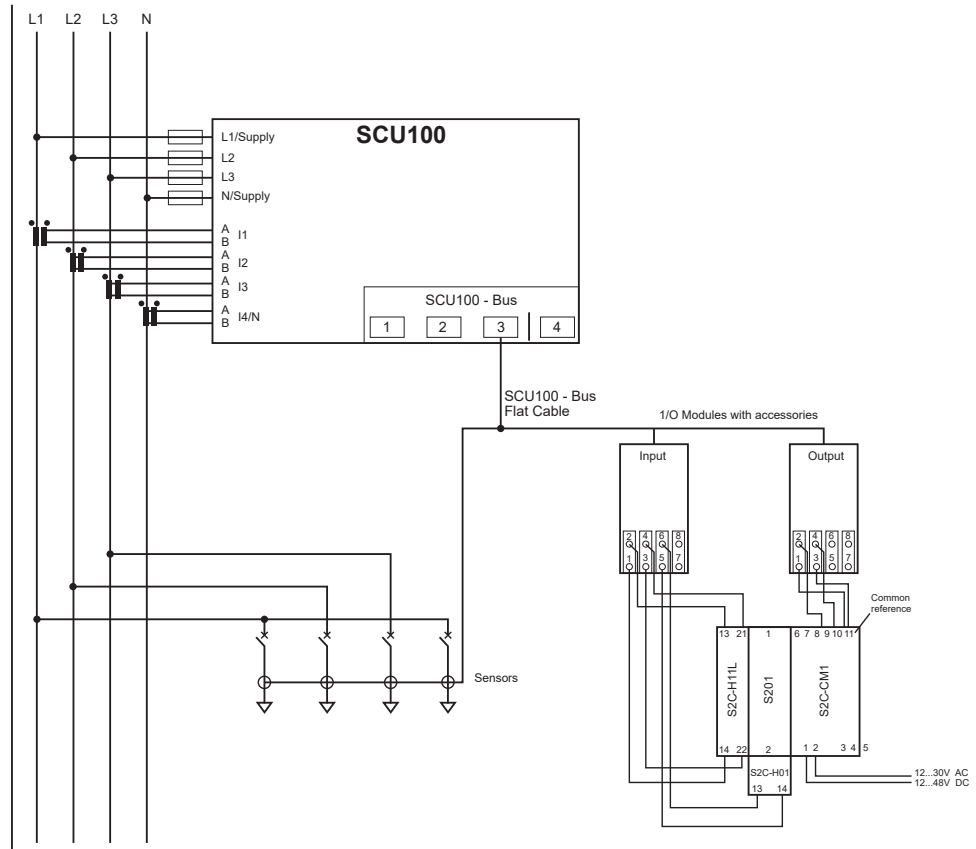

5.2.Memory architecture

SCU100 control unit has an internal memory where measured and computed values are stored.

Stored data includes measurements from control unit itself, energy and power meters, current sensors and I/O modules

The measured values of the main power network and those of the current sensors are stored in the following memory areas:

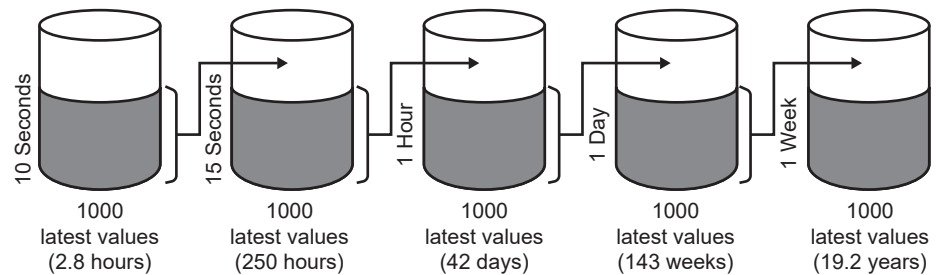

6. Installation

Warranty

Safe operation is ensured if assembly work has been carried out according to these user instructions. Furthermore, the instructions in the manual must be observed.

Authorized Personnel

Assembly, connection, and removal work should only be carried out by authorized and qualified personnel.

6.1. Control Unit

Assembly on 35mm DIN-Rail

To assemble the control unit, perform steps 1 and 2. The device can be mounted horizontally or vertically. To disconnect, perform steps 3, 4 and 5.

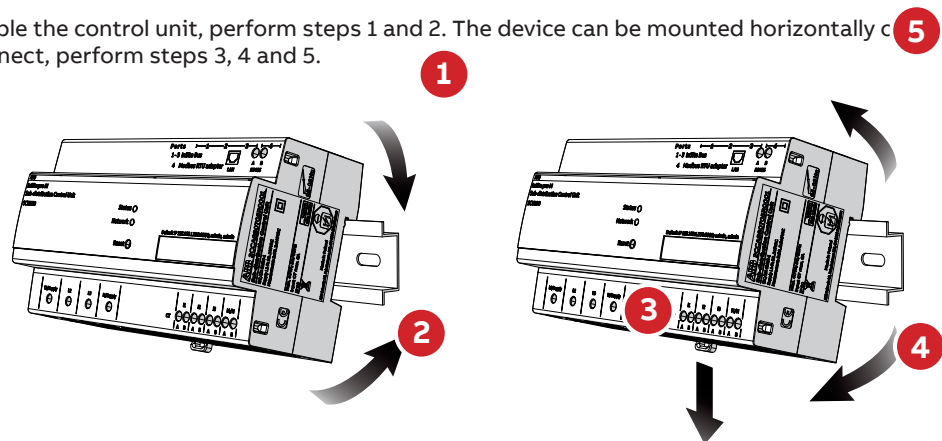

The SCU100 can be mounted on all 35 mm DIN rails (DIN50022). The device can be installed for single or three phase use. For commissioning a connection via LAN has to be established.

6.2.Assembly of connectors, current sensors and I/O modules

Assembly of connectors

Flat cable – Assembly of Connectors



Use the connectors only once.

Connect up to 32 current sensors, or 8 I/O modules (one module corresponds to 4 sensors), or a combination of current sensors and I/O modules, to each InSite Bus interface of the control unit. Consider the maximum flat cable length.

Flat cable should not exert force on the sensor, otherwise measuring errors may occur. Keep a distance of 5.5mm minimum between the flat cable and uninsulated live parts.



To check if specific combinations of devices can be connected and to calculate maximum flat cable length, please refer to the interactive tool available at this link:

<https://search-ext.abb.com/library/Download.aspx?DocumentID=9AKK107680A1691&LanguageCode=en&DocumentPartId=&Action=Launch>

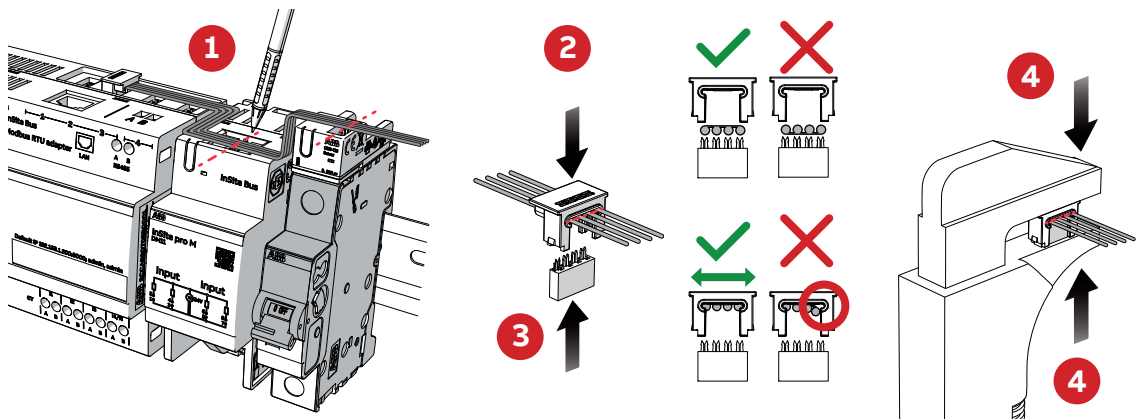

1. Mark the desired placement of the connector with a pen:
2. Press the flat cable into the cable duct of the connector housing.
3. Insert the connector into the connector housing at the marked position.
4. Press together using parallel pliers. Repeat the process at all other marks.



Attention: Pay attention to the correct orientation of the cable. Make sure that the cable is properly inserted into the connector housing.

Assembly of current sensors

• Position of the cable for current sensors

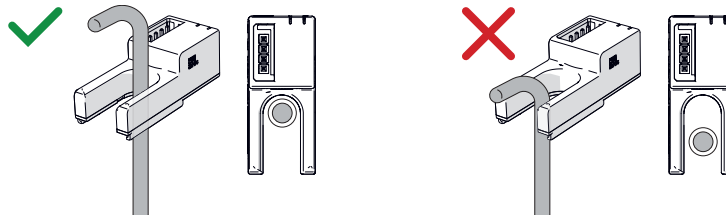

The cable must not bend directly above the sensor. If you use open-core sensors, make sure the cable is at the correct position, otherwise measuring errors may occur.

• Mounting of System pro M compact and SMISLINE Sensors



Sensors fit to all ABB installation devices with twin terminals. Flat cable should not exert force on the sensor, otherwise measuring errors may occur.

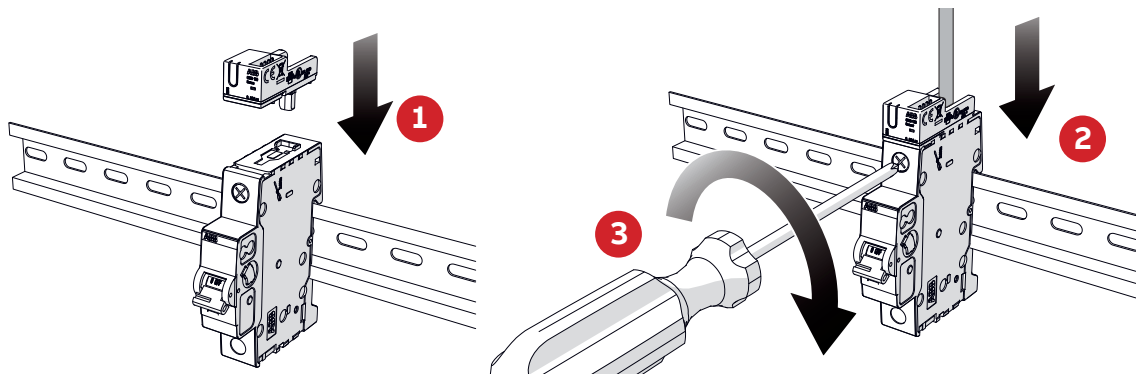

1. Unscrew the terminal of the installation device. Plug in the metal pin of the sensor into rear terminal connection.
2. Put the cable through the opening of the sensor into the installed device. The cable has to be insulated within the sensor!
3. Then tighten the screw.



Sensors fit ABB MCBs (S200, SMISLINE) and RCBOs (SMISLINE). Flat cable should not exert force on the sensor, otherwise measuring errors may occur.

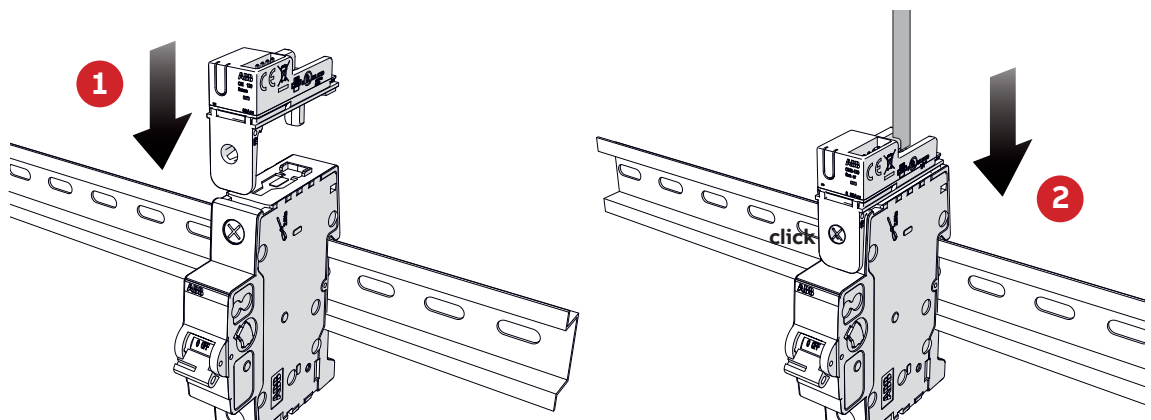

1. Insert the sensor on the existing device, in order to have the cable passing through the opening of the sensor.
2. Snap the adapter of the sensor on the upper screw hole of the already installed device.

• Mounting Sensors on DIN-Rails



Sensors can be mounted on all 35-mm DIN-Rails (DIN50022).
The cable should not exert force on the sensor, otherwise measuring errors may occur.

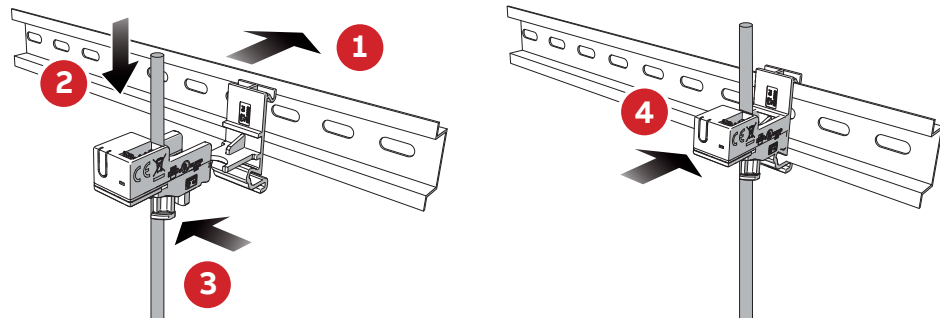

1. Snap in the bracket on the DIN-rail.
2. Insert the cable into the installed device through the opening on the sensor. The cable has to be insulated within the sensor.
3. Fix the cable with a cable tie.
4. Snap in the sensor on the bracket.

• Mounting of cable tie sensors



The cable should not exert force on the sensor, otherwise measuring errors may occur.

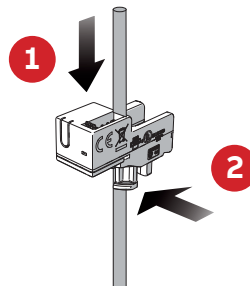

1. Insert the cable into the installed device through the opening on the sensor.
2. Fix the cable with a cable tie.

Assembly of I/O modules

• **Assembly on 35mm DIN-Rail**

To assemble of the control unit, perform steps 1 and 2. The device can be mounted horizontally or vertically. To disconnect, perform steps 3, 4 and 5.

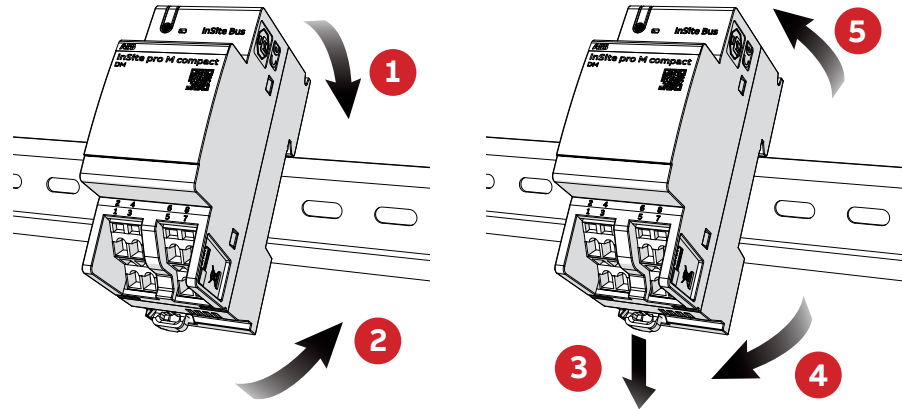

Final connection

Finally, connect the current sensors and the I/O modules to the control unit. Plug in the cable, check the correct connection direction. (Picture to the right)

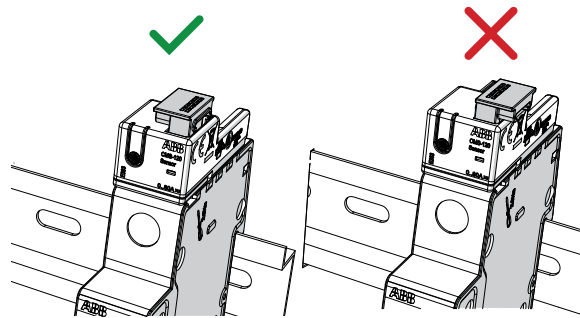

Attention: When plugging in the InSite flat cable on the sensors and I/O modules, check the correct connection direction.

6.3.Meters connection



Connect up to 16 energy and/or power meters.

Meters shall be connected in daisy chain configuration.

A and B terminals of the Modbus Adapter are wired as follows

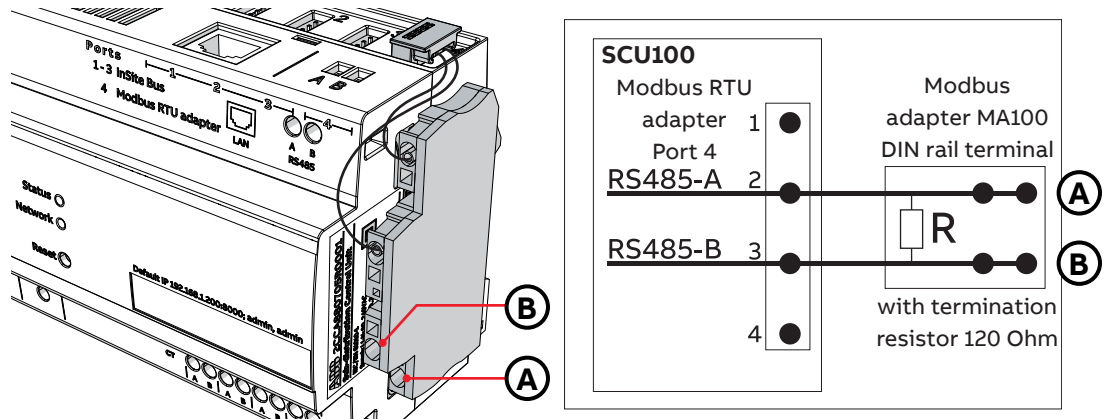

Attention: Do not to invert **A** and **B** communication terminals as this will prevent communication.

To make the connection, follow the procedure below.

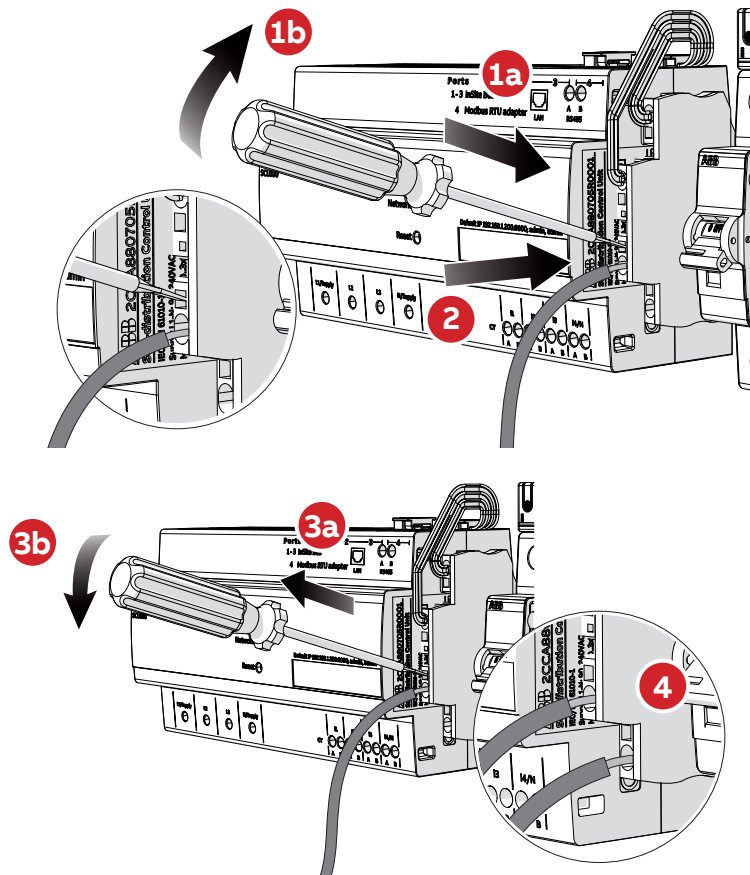

1. To connect energy and power meters, mount the Modbus Adapter on the DIN-Rail and open the terminal with the screwdriver
2. While holding the terminal open, insert the wire for Modbus communication in the terminal.
3. Remove the screwdriver
4. Repeat the procedure for the second cable.

7. Wiring diagram

The operations to carry out for the correct connection and wiring of the control unit and the I/O modules are described in this section.

7.1. Control unit

Connection of SCU100 is based on the type of electric line available.

The SCU100 includes an own power supply on L1-N. No external power supply is required.

The contacts I1, I2, I3, I4/ N are provided for connecting the external current transformer.

Installation to mains

Installation of SCU100 to mains shall include a switch or a circuit breaker for the connection to them.

The switch or circuit breaker must be suitably located and easily reachable and must be marked as the disconnecting device for the SCU100.

Disconnection from mains or connection to mains

Switch off circuit breaker or switch before disconnecting from the mains supply or connecting to the mains supply. Same applies for all other connections (L1, L2, L3, N).

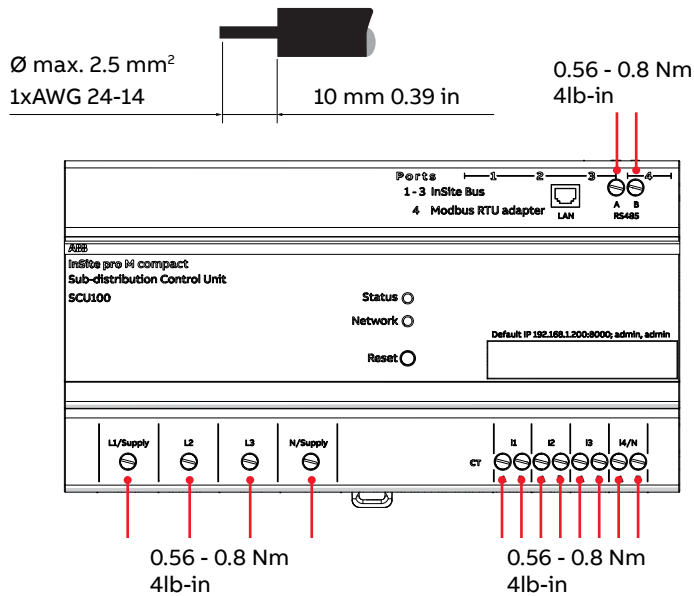

Attention: The installation and the cabling of the device must be carried out by qualified personnel. Danger of electrocution, burning and electric arc. Use the personal protection devices suitable to adhere to the current regulations governing electrical safety. Prior to carrying out any connections check the sectioning of the electric supply with the voltage detection device.

Three phase plus neutral

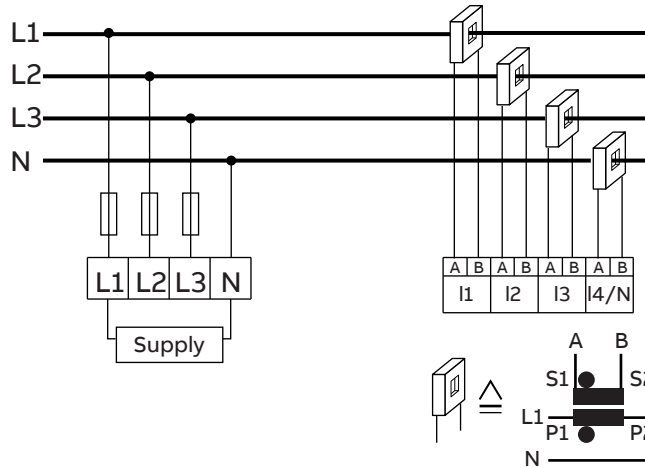

Attention: Please, referring to the diagram in the figure aside, notice that N on the supply has to be connected in order to avoid damage of the device.

Attention: Make sure that N is not mixed up with the phases L1, L2, L3.

Attention: CT output should not be connected to the earth. It is not possible to connect more than one SCU in series with the same CT.

Single phase neutral

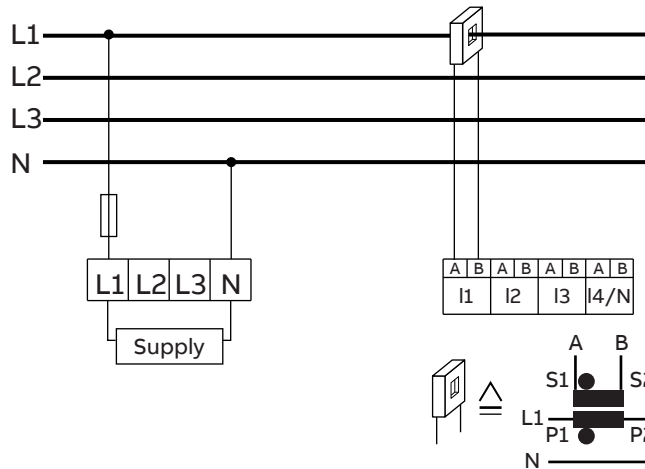

Attention: Please, referring to the diagram in the figure aside, notice that N on the supply has to be connected in order to avoid damage of the device.

Attention: Make sure that N is not mixed up with the phases L1, L2, L3.

Attention: CT output should not be connected to the earth. It is not possible to connect more than one SCU100 in series with the same CT.



If the single phase installation has been adopted for both voltage and current it will not possible to measure power and energy for L2 and L3 also at branch level.

I/O modules

Connection of input and output channels to accessories and external devices is represented in the figure below.



For sake of representation, connection to signal/auxiliary contacts and to loads is shown.

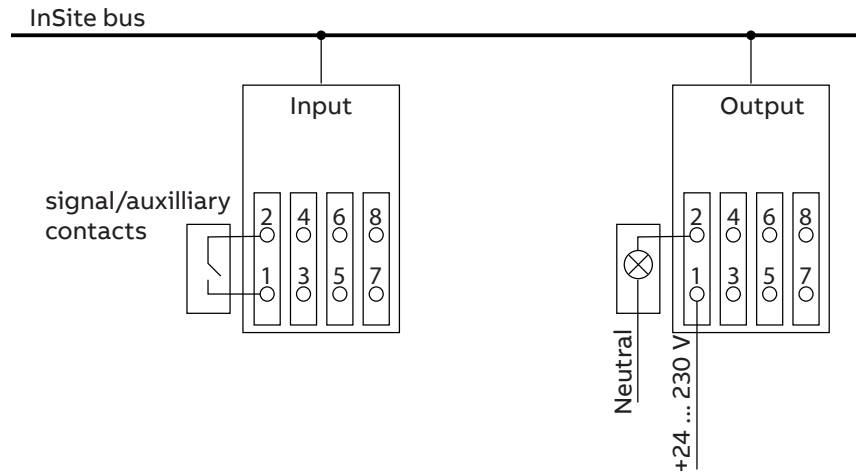

For output channels external power supply with overcurrent protection (by fuse or internal functionality) is required.



- 24VDC is maximum value of DC, can also be lower.
- 230VAC is maximum value of AC, can also be lower.

Do not connect AC to DC to the input terminal: no external supply of input is allowed, it will permanently damage the device.

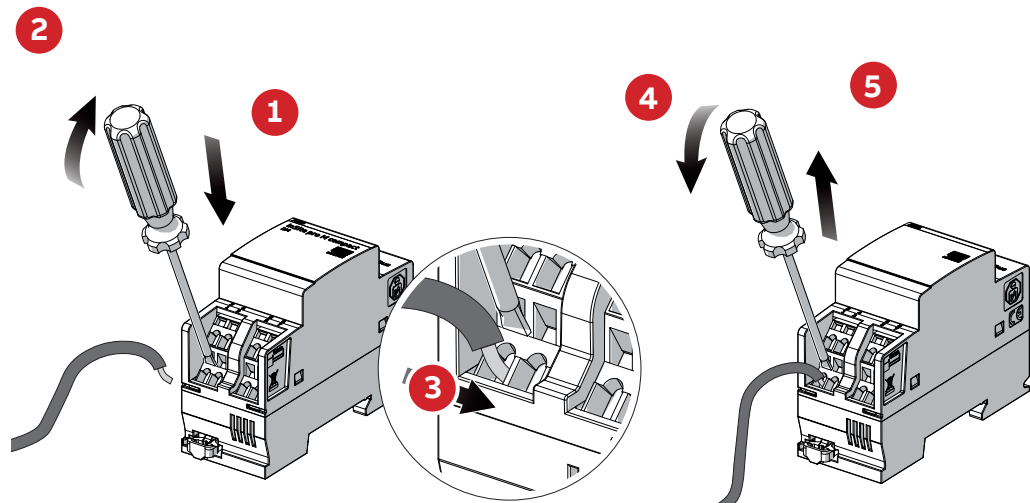

8. Access to control unit

Static access with default factory setting		Details
1	Access to web user interface with default IP of control unit	192.168.1.200:8000
2	Define static IP address for PC, for example: Make sure the IP address in the assigned LAN is not used twice. If it is used twice, an adjustment is required.	192.168.1.5 192.168.1.x (x = 2...199, 201...255)
3	Subnet Mask	255.255.255.0
4	DHCP access Note: If you change after initial commissioning for DHCP access	Hostname: Insite
5	Download latest software version here: https://search-ext.abb.com/library/Download.aspx?DocumentID=9AK-K107680A3552&LanguageCode=en&DocumentPartId=&Action=Launch	



For the first setup you have to use the direct LAN connection. Follow instructions under section “Direct LAN Connection”



Check the internal time of the device. If it is not correct, it has to be set manually. For further information about manual time setting, see “Settings-General-Time”.

8.1. Network connection

The following sections show the steps needed to set up the SCU100 control unit.

The control unit can be used in different operating modes:

- LAN connection via router
- Direct LAN connection
- Additionally, data are available through serial port Modbus RTU (RS485). For further information, consult the dedicated document.

LAN connection via router

The SCU100 control unit is connected to the router using a RJ45 cable (network).

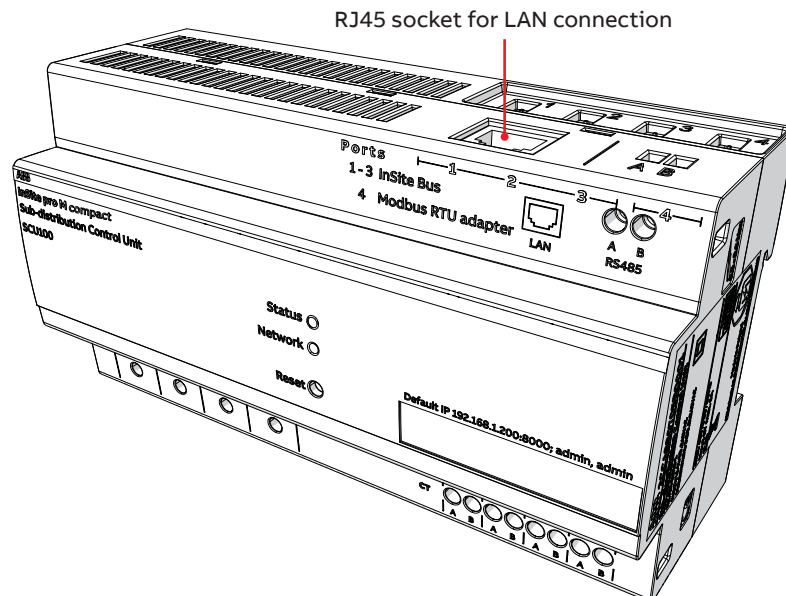

Accessing the Web UI via IP address



Port 8000 to be added to the IP address 192.168.1.200 to define the port number (e.g. 192.168.1.200:8000) to access your web browser. Defining the port number is important because without a port number access is not possible.



In case of DHCP, the system administrator can read the IP address assigned to the SCU100 device by DHCP on the router.

Direct LAN connection



For network connection, an access with static address may be necessary in the first step.
IP Address: 192.168.1.200:8000 / Subnet Mask: 255.255.255.0

The control unit is set up using a web interface. To connect a PC or laptop to the SCU100 without DHCP, you need to configure the LAN interface with a static IP address. Using the example of Windows, the following shows the configuration steps.

Select Control Panel → Network and Sharing Center →



Adjust your computer's settings

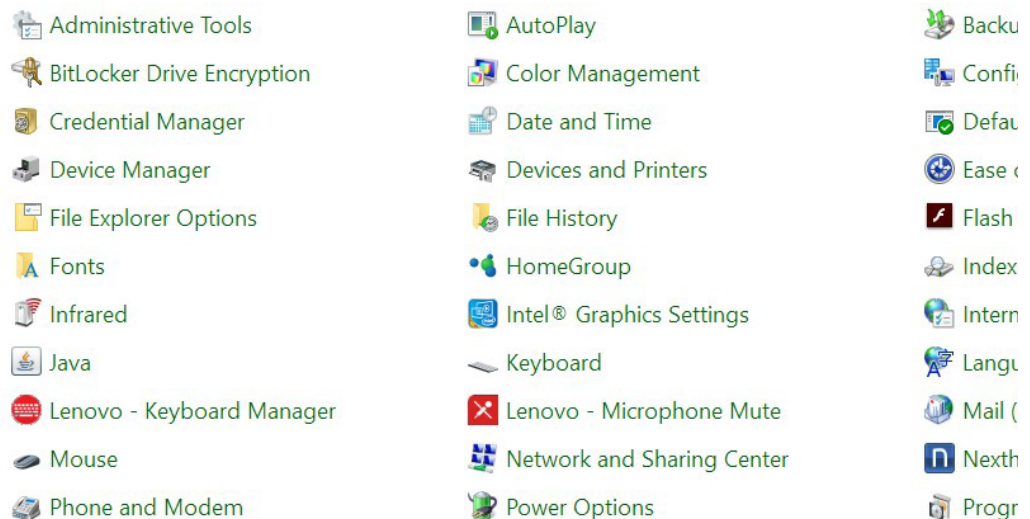

→ Change adapter settings (on the left) → Ethernet

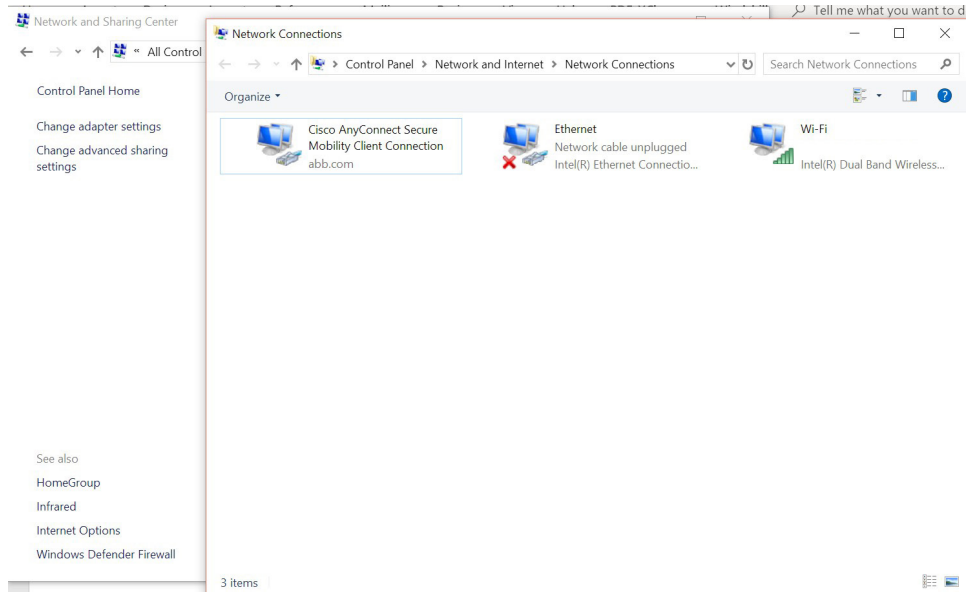

→ With right click select Properties → double click Internet Protocol Version 4 (TCP/IPv4)

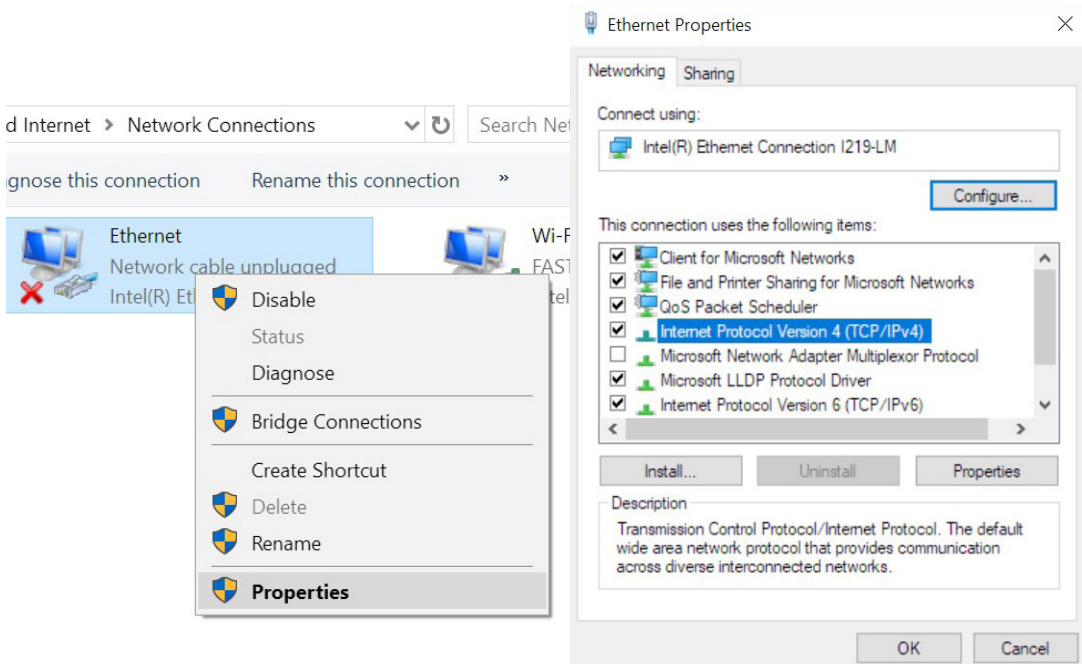

→ Enter IP Address: 192.168.1.5 and Subnet Mask: 255.255.255.0 and confirm with OK.

Make sure that the IP address on the LAN is not already taken. In case it is taken, adjustments are necessary. (192.168.1.x; x = 2...199, 201...255)

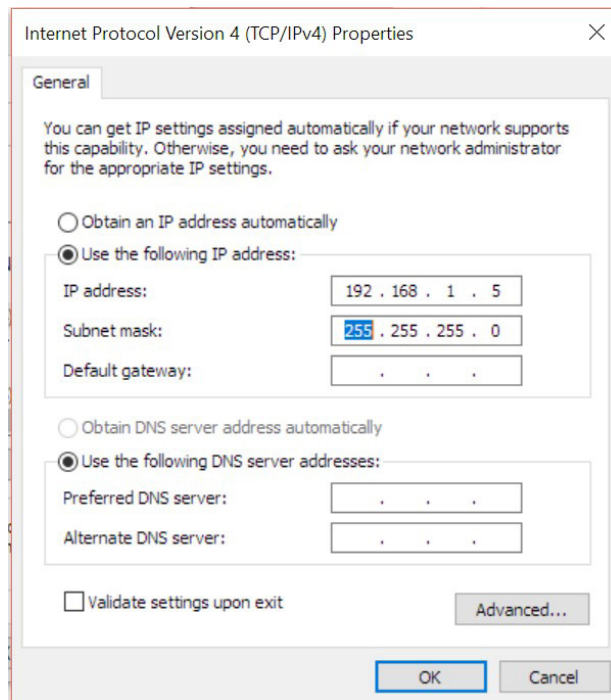

→ Now connect your device to the SCU100 control unit

8.2. Control unit login



The web user interface is designed for use on browser-based devices. The recommended web browser is Google Chrome, other supported web browsers are Safari, Firefox, Opera, Internet Explorer.

Start screen (login)

Insert the IP address of the device in the browser address bar.

To access the web browser, it is also important to define port number 8000.

Factory settings with:

- Default IP: 192.168.1.200:8000
- Default login → username: admin, password: admin

InSite WebUI
Enter username and password to get access to InSite web user interface

* Username:

* Password:

[Download certificate](#)

[Terms of use](#)



Please note that the control unit uses a secure **https://** connection and port **7999**.

First, it is necessary to confirm the secure connection. Later on you won't be asked to confirm it provided that you upload the SSL Certificate as described in the dedicated section.

At first login, user will be prompted to change the administrator login data. It is highly recommended to change the administrator login password to improve cyber security. The new password must contain minimum 8 characters, at least one uppercase letter and one number.

9. Web User Interface

Here the Web User Interface (WebUI) structure is shown. It is divided into two main areas: Operation and Settings area.

On the one hand, the Operation area covers all pages where collected data is displayed and the system is controlled.

On the other hand, the Settings area covers all pages where the system can be configured.

9.1. Structure

System WebUI structure			
Operation area	Monitor	Dashboard	
		Real-time values	
	Real-time values	Control unit	
		Current sensors	
		Meters	
		Inputs/Outputs	
		Modbus RTU devices	
	Analytics		
	Control		
	Settings area	Configuration	Control Unit
Current sensors			
Meters			
Inputs/Outputs			
Modbus TCP Slaves			
Modbus RTU Devices			
Setting		Groups	
		Tree view	
		Alarms	
		Automation	
		Export/Import	
		Users	
		Email, FTP	Email
			FTP
		Communication	IP
			SNMP
			SNMP trap
			Modbus
			VPN
			Rest API
	Cloud gateway client		
SSL certificate	Upload		
	Generate		
General	Time		
	Session		
	Firmware update		
	System		

10.Web UI - Configuration

In order to start the configuration of the system, follow the instructions and indications detailed in this chapter, both “Configuration” and “Settings” menu.



Safe shutdown: to make sure all settings are saved, it is recommended to carry out a safe shutdown before power off (Settings → General → System / Safe shutdown).

The screenshot shows the ABB InSite web UI Configuration page. The top navigation bar includes 'ABB InSite', 'Monitor', 'Analytics', 'Control', 'Configuration', and 'Settings'. The 'Configuration' menu is expanded to show 'Users', 'Email, FTP', 'Communication', 'SSL certificate', and 'General'. The 'System' sub-tab is selected, showing options for 'Time', 'Session', 'Firmware update', and 'System'. The 'System' section contains three main actions:

- System reset:** Press the button below to restart your device with the current settings. A 'Restart' button is visible.
- Restore default settings:** Press the button below to restart your device with the factory settings. WARNING! All of your previous settings will be lost! A 'Restore default' button is visible.
- Safe shutdown:** Here you can safely shutdown device without the risk of losing your configuration. A 'Shutdown' button is visible.

10.1.Devices

Control Unit:

It is possible to set frequency, external CT ratio for phases and neutral, and reference DC voltage, if needed.

The screenshot shows the ABB InSite web UI Configuration page for the Control Unit. The top navigation bar includes 'ABB InSite', 'Monitor', 'Analytics', 'Control', 'Configuration', and 'Settings'. The 'Configuration' menu is expanded to show 'Users', 'Email, FTP', 'Communication', 'SSL certificate', and 'General'. The 'General' sub-tab is selected, showing options for 'Time', 'Session', 'Firmware update', and 'System'. The 'System' section contains three main actions:

- System reset:** Press the button below to restart your device with the current settings. A 'Restart' button is visible.
- Restore default settings:** Press the button below to restart your device with the factory settings. WARNING! All of your previous settings will be lost! A 'Restore default' button is visible.
- Safe shutdown:** Here you can safely shutdown device without the risk of losing your configuration. A 'Shutdown' button is visible.

The CT ratio for L1, L2, L3 has to be the same, while it can be different for N.

The CT ratio is calculated dividing the primary rated current by the standard secondary current (5A).



Current of mains are measured by CTs.

DC voltage reference is needed to calculate DC power at branches level, in case the current sensor measures DC current (see section “WebUI Configuration – Devices – Current sensors”).

Current Sensors

The menu allows to have access to the information briefly listed below together with the buttons you can use. It is possible to use Selection Filter and Sort Function on Phase, Node and Group labels to find desired values. It is also possible to add new sensors by own defined ID number, to change the ID number and to set a LED off timeout if desired.

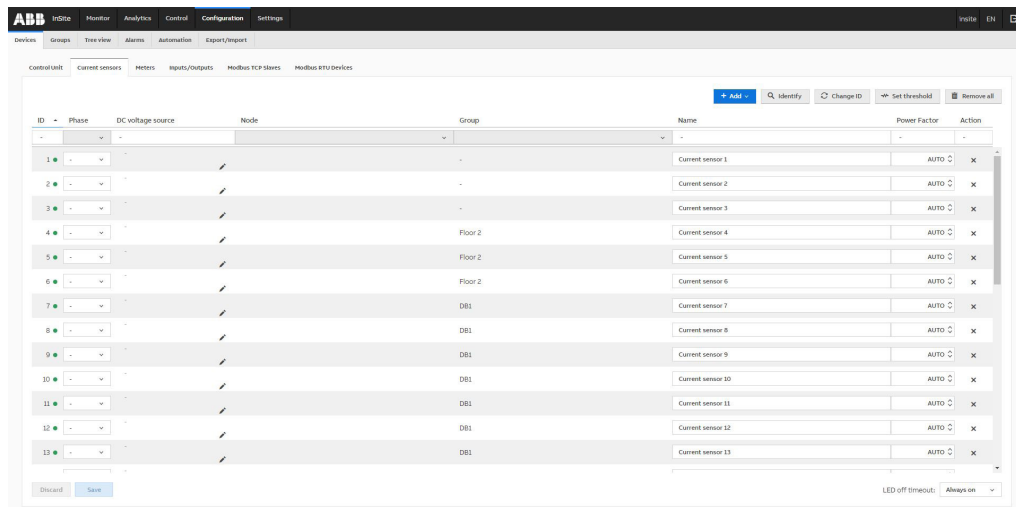

Buttons

Add

Add and assign new current sensor	Create a new sensor ID and then assign it to the physical sensor by clicking the pushbutton of the sensor (Note: Wait for confirmation before assigning the next sensor)
Assign current sensor (already added)	If a sensor ID has already been created but is unassigned, it is here possible to assign it to the physical sensor by clicking the pushbutton of the sensor.
Add new current sensor (no assigning)	Create a new branch ID without assigning it to the physical sensor.
Identify	Clicking the pushbutton of the current sensor allows to display the sensor ID number.
Change ID	Select the current ID number of the current sensor and define the new ID number of it.
Set threshold	Set the current threshold value (mA) below which the measures of all configured sensors are zeroed
Remove all	Remove all sensors and their settings. To remove one single sensor click on the "X" symbol under the Action column

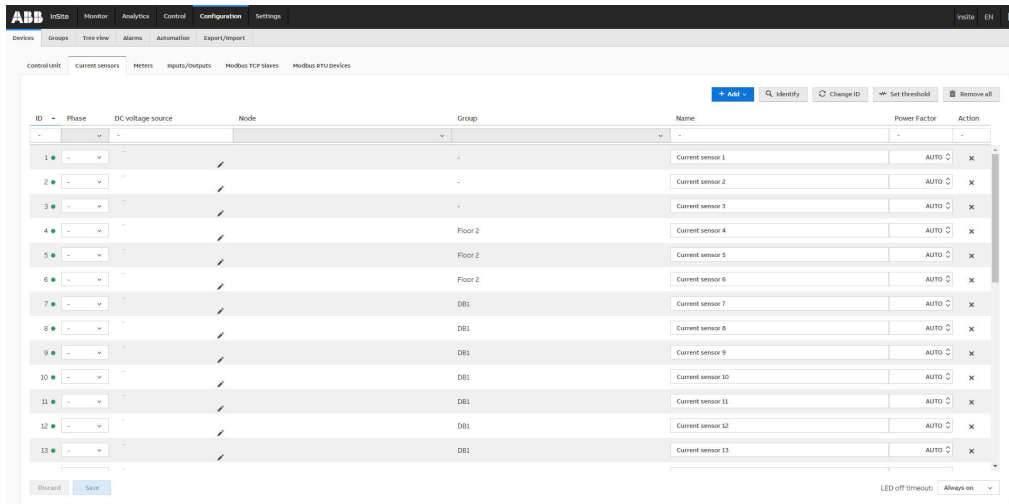

Sensors Definitions

ID	Sensor identification number (at this time it cannot be modified)
Phase	Selects the corresponding sensor phase for the calculation of sensor active power and energy. It is possible to choose: - L1, L2, L3, N for alternate current measurements - DC for direct current measurements.
DC voltage source	Defines voltage source for DC power and energy calculation. This option can be configured by clicking on pen icon, only when DC phase is selected for specific sensor. Refer to “DC voltage source” paragraph for further information.
Node	Defines the node in which the sensor is assigned in the “Tree view” configuration. It is automatically filled once the sensor is configured in the “Tree view” page
Group	Defines the group in which the sensor is added in the “Groups” configuration. It is automatically filled once the sensor is added in the “Groups” page
Name	Defines the name of the sensor. It must be unique and can be composed by up to 64 characters
Power Factor	Defines which power factor shall be used for calculation: AUTO - uses the Power Factor of defined mains phase x.xx - you can manually define a constant power factor (e.g. 0.85) 0 - type zero for changing from manual to auto power factor
Action	Remove the single sensor
[Click a row]	By clicking a row, the row is highlighted in light blue and the corresponding box is checked. Additionally the LED of the selected sensor will start to blink. After removing checkboxes row is not highlighted anymore.



Make sure to select the correct phase on which the current sensor is installed in the phase column. If needed, change the Power Factor (PF) from Auto to a manual value corresponding to the PF of the measured load.

DC voltage source

When the pen icon is pressed, following prompt will appear

Set the voltage source for the power calculations for current sensor.
You can select constant value or RTU register with [V] unit.

Type:

User will be asked to specify the value of “per branch” DC voltage, used in power and energy calculations for specific sensor. Following options are available:

- Constant mains value – Global DC voltage value configured on page “Configuration - Devices - Control Unit”
- Constant sensor value – Numeric value in volts assigned to specific sensor by “Value” input field
- RTU register – Value stored in third party Modbus RTU device register, that is periodically read by control unit. Any register with unit “V” can be selected. Refer to chapter 10.3 for further information.

Sensor status dot indicator colors

Sensors status dot indicator colors	
● Green	sensor is assigned and operational
● Red	sensor is unassigned or not responding
● Yellow	sensor is assigned and operational, but the RTU register assigned as voltage source is not responding or was removed from configuration by user. In this situation only electric current is being measured

Meters

The menu allows to have access to the information briefly listed below together with the buttons you can use. It is also possible to add new meters. To do so click on “Add meter”: it is possible to detect automatically the type of meter connected by clicking on “Detect model” (not valid for IM300 model) or to select the model from different options. Default values for each parameter will appear according to the meter selected: these values can be changed manually if required as well as the ID number of the device.

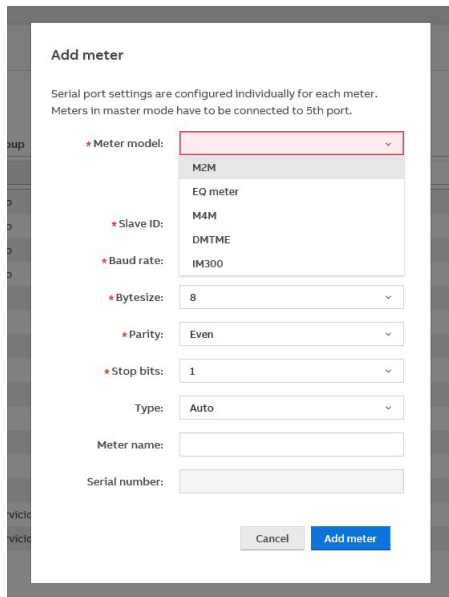
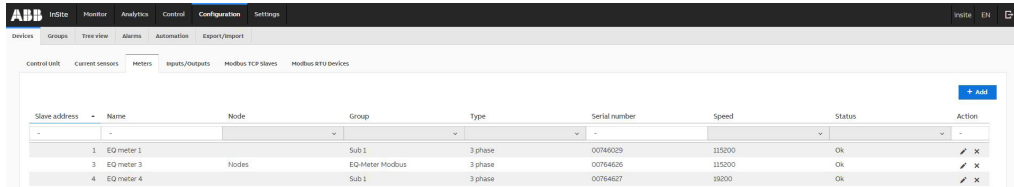

Buttons

Add

Slave ID	Assign an ID number (between 1 and 16)
Detect model	Meter type auto detection (not available for IM300)
Baud rate	Select the baud rate among the ratings (from 2400 to 115200)
Bytesize	Select the Byte size among the ones available (7, 8 or 9)
Parity	Select the parity among the ones available (none, odd, even)
Stop bits	Select the Stop bit among the ones available (1 or 2)
Type	Select between 1 phase or 3 phase
Meter name	Set the name of the meter
Serial number	Insert the Serial Number of the meter

Inputs/Outputs

It is possible to configure I/O ports of both I/O modules and connected meters (if available). If “Modules” has been selected as a source:

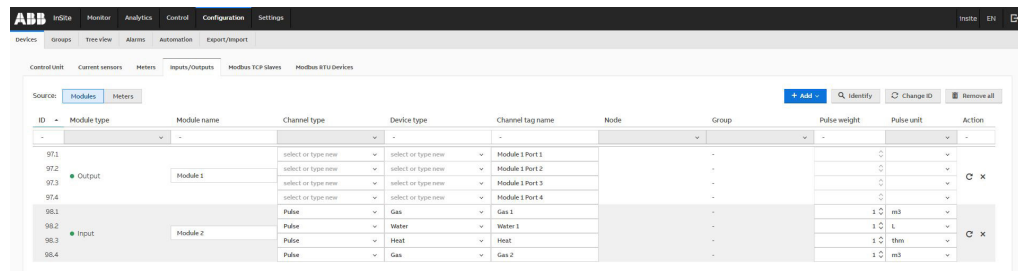

Buttons

Add

Add and assign new I/O Module	Create a new I/O Module ID and then assign it to the physical module by clicking the pushbutton on it (Note: Wait for confirmation before assigning the next sensor)
Add new I/O Module (automatically)	Create a new I/O Module ID by automatically assigning it to the physical module randomly (Note: wait for confirmation pop-up window before configuring the modules detected)
Assign I/O module (already added)	If a I/O Module ID has already been created but is unassigned, it is here possible to assign it to the physical module by clicking the pushbutton on it.
Add new I/O Module (no assigning)	Create a new I/O Module ID without assigning it to the physical module. It is possible to select the type of the module to be add (Input, Output, Input/Output)
Identify	Clicking the pushbutton of the I/O Module allows to display the sensor ID number.
Change ID	Select the current ID number of the I/O Module and define the new ID number of it.
Remove all	Remove all I/O Modules and their settings. To remove one single module click on the “X” symbol under the Action column

It is possible to assign addresses to the I/O modules automatically. In order to start auto-assignment process it is required to select option “Add new I/O Modules (automatically)”: the process runs automatically according to the following steps

1. Starting of the auto-assignment process

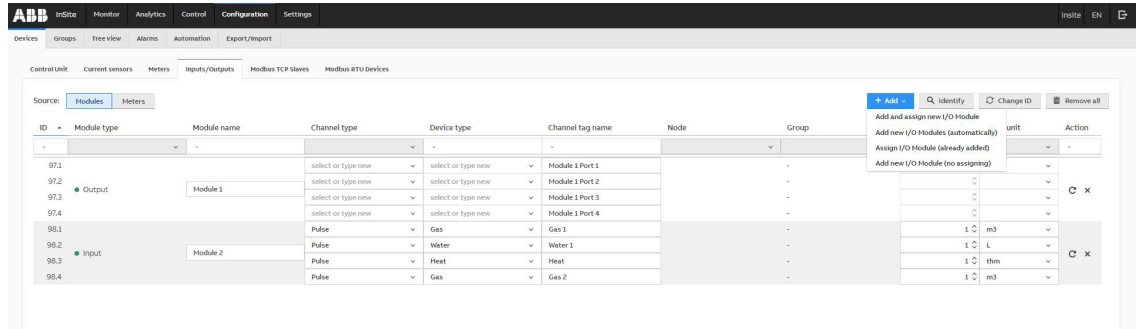

2. Assigning addresses to the I/O modules.

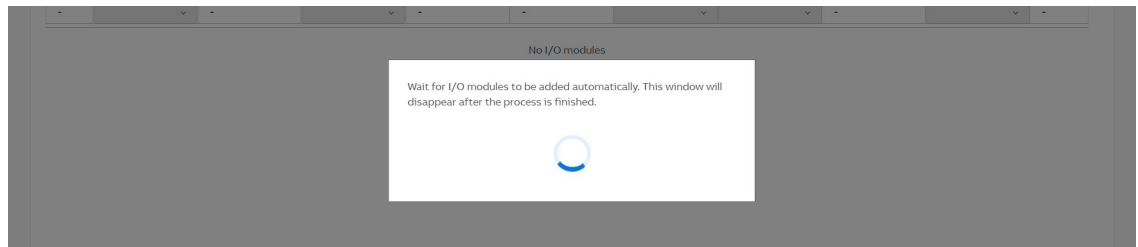

3. Information about number of added I/O modules

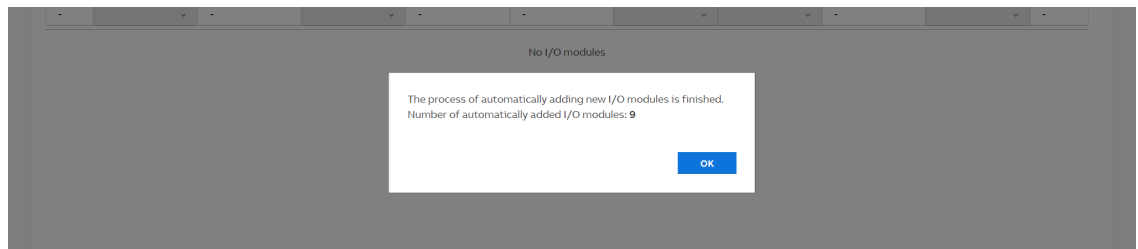

4. WebUI loads all added I/O modules.

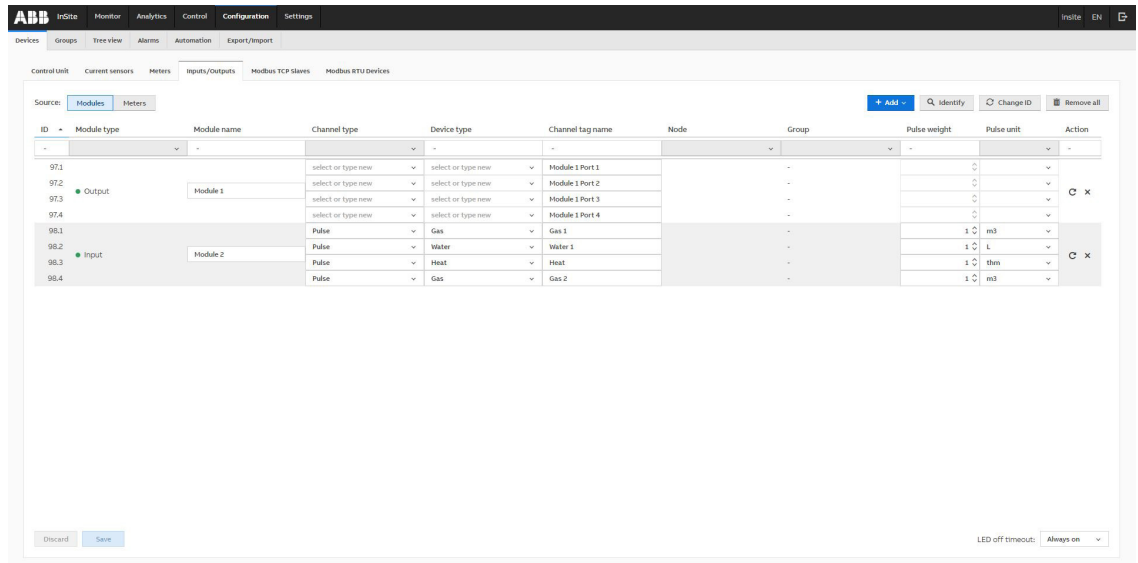

I/O Modules Definitions

ID	Module identification number (at this time it cannot be modified): it starts from 97 and the last digit indicates the channel number of the module
Module type	It is automatically recognized when the module is added and assigned.
Module name	It is possible to define the module name (max 30 ASCII characters)
Channel type	It is possible to select the channel type from dropdown menu. If a new channel type is needed it is possible to create a new one by typing a new one.
Device type	It is possible to select the device type from dropdown menu. If a new device type is needed it is possible to create a new one by typing a new one.
Channel tag name	It is possible to define the channel tag name (max 30 ASCII characters)
Node	Defines the node in which the channel is assigned in the "Tree view" configuration. It is automatically filled once the channel is configured in the "Tree view" page
Group	Defines the group in which the channel is added in the "Groups" configuration. It is automatically filled once the channel is added in the "Groups" page
Pulse weight	In case of pulse type channel it is possible to define the weight for the received pulses. The minimum number is -10000
Pulse unit	In case of pulse type channel it is possible to select the unit of measurement from the dropdown menu
Action	
Reset	Resets all the settings of the related module
Remove	Removes the related module
[Click a row]	By clicking a row, the row is highlighted in light blue and the corresponding box is checked. Additionally the LED of the selected sensor will start to blink.

To add meter IO ports to Insite select “Meters” as a source, click to “Add/Rescan”, then choose meter from the list.

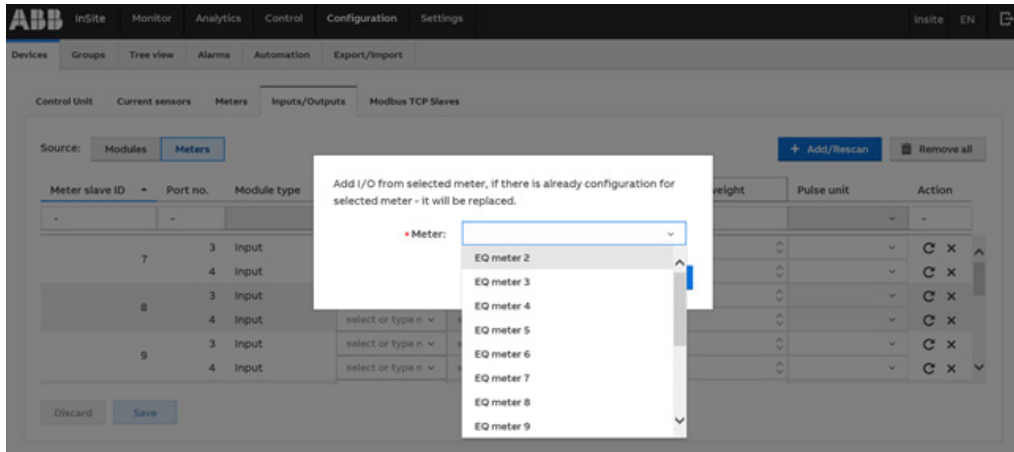

Buttons	
Add/Rescan	
Add new I/O ports from meters	Create a new I/O port from the selected meter (if already connected and configured). Once created it is possible to select the Channel Type, the Device Type and change the Channel tag name
Remove all	Remove all the meters and their I/O settings. To remove one single I/O port click on the “X” symbol under the Action column

In the following table supported port features are listed (in particular meter model vs. port configuration):

Port Configuration	Monitor Value	Monitor Counter	Control
Input / Pulse input	EQ/IM300/M4M/M1M	EQ/M4M/M1M	-
Tariff Input	EQ/M4M	-	-
Communication Output	EQ/M4M/IM300	-	EQ/M4M/IM300



- IM300 IOs are not configurable.
- EQmeter/M4M IOs can be configurable only in terms of their functionality (ex. Input/Tariff Input), but also in terms of their type (Input/Output) depending on meter configuration.
- When EQmeter/M4M IO is configured to not supported type (ex. Pulse output) it will not be detected.
- Functionality may depend on meter software version

• **Limitations**

- User is responsible for proper port configuration
 - IM300 Outputs are set to pulse by default. After writing “1” output will change to “0” after “Pulse Length” time (can be changed via meter UI or registers 0x40081, 0x40088)
 - EQmeter/M4M outputs are set to Pulse Output by default (Can be changed via meter UI or configuration registers), hence they will not be detected if the configuration is not changed
- Historical data is not supported
- Changes in IO port configuration are not auto detected: user must follow procedure described for adding meter IO ports in order to refresh IO configuration
- Up to 4 ports for EQmeter and M4M are supported
- Register descriptions in external Modbus match naming scheme from corresponding meters user manuals. Port numbering in WebUI is the same for all meter types - follows EQmeter/M4M Scheme. For IM300 IO external Modbus registers port numbering is separate for inputs and outputs.

Example:

Input/Output X - description and number in external Modbus

(x) – port number in webui

Ports names in EQmeter/M4M

(Number is associated with IO slot - every port index is unique)



Input	Output
Input 1 (1)	
Input 2 (2)	
	Output 3 (3)
	Output 4 (4)

Ports names in IM300

(Separate indexes for inputs and outputs)

Input	Output
Input 1 (3)	Output 1 (1)
Input 2 (4)	Output 2 (2)
Input 3 (5)	
Input 4 (6)	

10.2.Modbus TCP Slaves

In this section it is possible to add external Modbus TCP devices connected in the same LAN of SCU100 whose registers you want to be read by InSite Rest API interface. The values read are included in Rest API only and are not shown in WebUI.

To add a new Modbus TCP slave click “Add”, fill in the required fields (“Device IP”, “Name” and “Port”) that identify the device and define the specs of the holding register you want to be read. To add new registers click “Add register”. When the configuration is finished click “Add Modbus TCP slave” to complete the process.

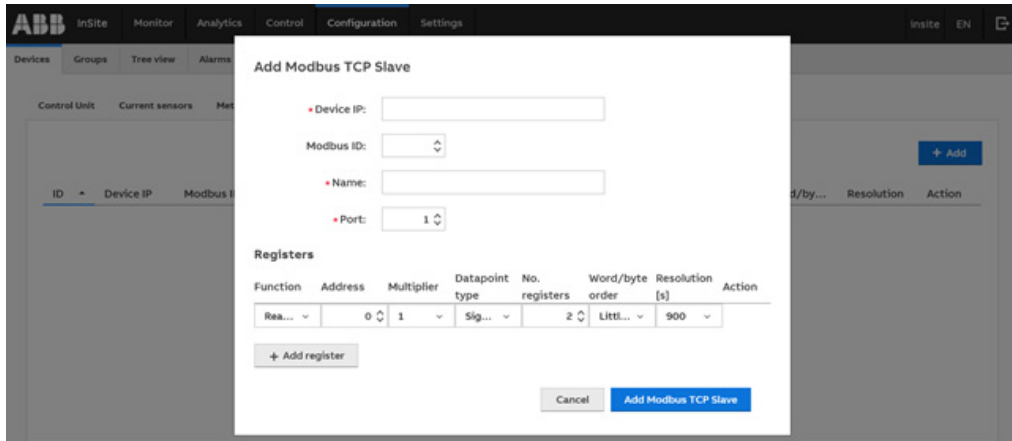

If device is working in “Master” mode, it is possible to add multiple devices with same IP address but different Modbus IDs. Maximum number of devices is 32, 4 registers per each device.

Registers are read based on configured resolutions. For connected device each register is read 3 times before response is set to “NOT CONNECTED”.

If device is not responding, reading will be retried every 5min. Each not responding device can delay initial and other readings by ~2s.

Values read from devices are available via Rest API, it has to be enabled (Settings->Communication->Rest API – read Rest API manual section).

POST: /api/gateway/data

Get all data from all configured Modbus TCP devices:

```
{
  "data": [
    {
      "protocol": "tcp"
      "type": "online"
    }
  ]
}
```

Get all data from one device:

```
{
  "data": [
    {
      "protocol": "tcp",
      "slave_ip": "192.168.1.200"
    }
  ]
}
```

Get all data from one device with selected modbus_id:

```
{
  "data": [
    {
      "protocol": "tcp",
      "slave_ip": "192.168.1.200",
      "modbus_id": 1
    }
  ]
}
```

Get one register from one device:

```
{
  "data": [
    {
      "protocol": "tcp",
      "slave_ip": "192.168.1.200",
      "modbus_id": 1,
      "addresses": [36866]
    }
  ]
}
```

Response example:

```
{
  "ip": "192.168.1.200",
  "id": "insite",
  "data": [
    {
      "slave_ip": "192.168.1.200",
      "modbus_id": null,
      "timestamp": 1593174314,
      "values": {
        "36866": 242.32,
        "36868": 241.68
      }
    }
  ]
}
```

Get historical data

e.g

```
{
  "data": [
    {
      "protocol": "tcp",
      "type": "historical",
      "begin_timestamp": 1593586022,
      "end_timestamp": 1593589022
    }
  ]
}
```

Historical data for Modbus TCP Slaves are configurable: user can select how many days are stored in database (maximum 366 days if there is enough space for all the data).

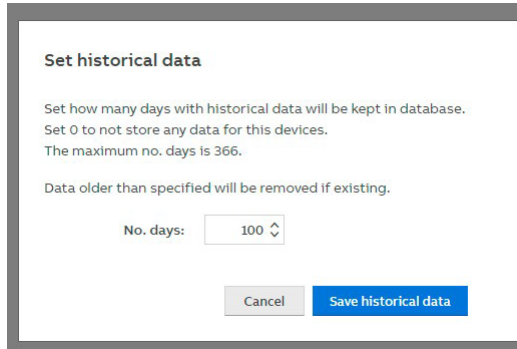

10.3. Modbus RTU Devices

In this section it is possible to add Modbus RTU devices connected to the SCU100.

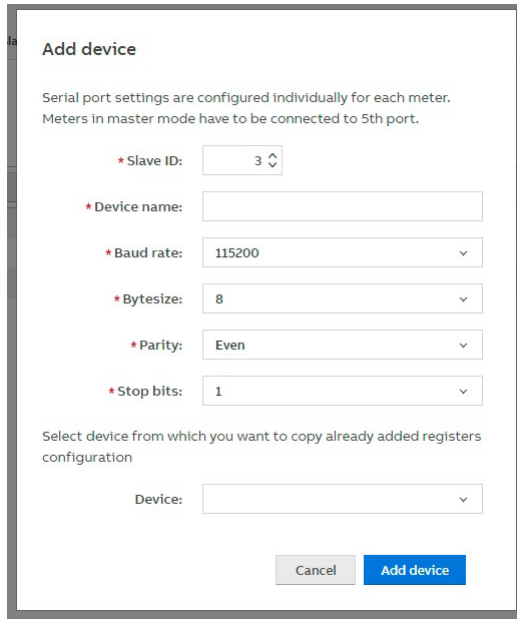
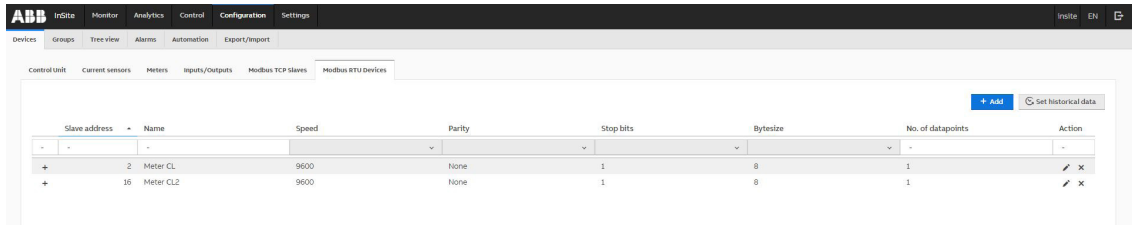

Buttons

Add

Slave ID	Assign an ID number (between 1 and 16)
Device name	Set the name of the device
Baud rate	Select the baud rate among the ratings (from 2400 to 115200)
Bytesize	Select the Byte size among the ones available (7, 8 or 9)
Parity	Select the parity among the ones available (none, odd, even)
Stop bits	Select the Stop bit among the ones available (1 or 2)
Device	Select device from which registers should be copied (leave empty if registers should not be copied from other device)

Clicking on “Set historical data” user can select how many days are stored in database, maximum 366 days if there is enough space for all the data (same as for Modbus TCP Slaves)

Add register

Buttons	
Add	
Address	Assign register address (between 0 and 65535)
Category	Select the category of the register
Value	Select the value of the register
Name	Set the name of the register (Only for category „Custom”)
Insite address	Address of the register in SCU100 modbus register map based on Category/Value
Datapoint type	Type of the data based on Category/Value
Multiplier	Set the multiplier of the register among the ones available (1, 0.1, 0.01, 0.001)
No. Registers	Set the number of registers
Word/byte order	Select the word/byte order among the ones available (Big-endian, Little-endian, Big-endian byte swap, Little-endian byte swap)
Unit	Select the unit of the register (select unit or create new by putting it and pressing enter)
Resolution	Select the resolution how often register will be read and stored in historical values (possible resolution 10s, 30s, 900s).

10.4.Groups

This page allows to create or remove groups of devices.

By clicking on “Add new”, it is possible to create a new group by selecting the type of the devices.

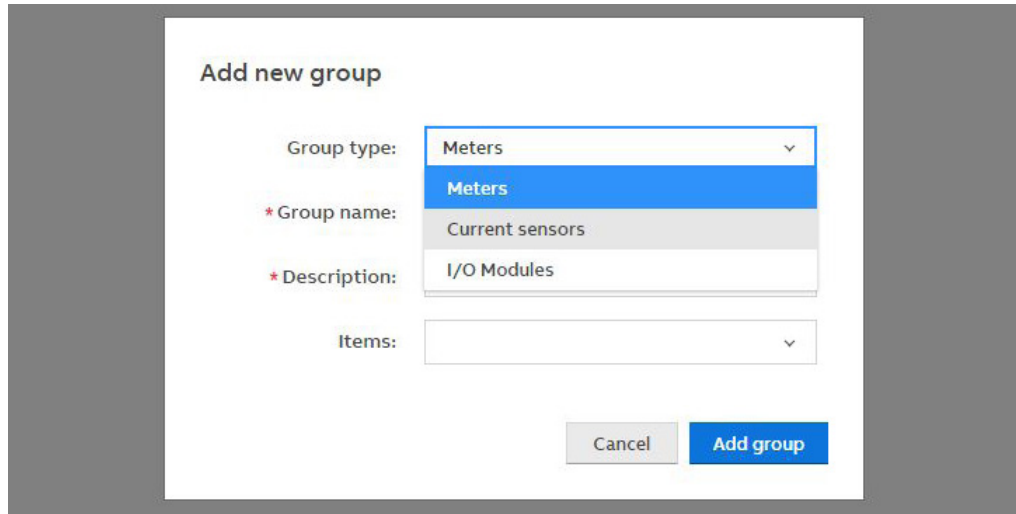

Once a group type has been selected, it is required to type the name of the group and add a description. For each group it is possible to associate one or more items.



Please note that it is possible to associate a device to a single group only.

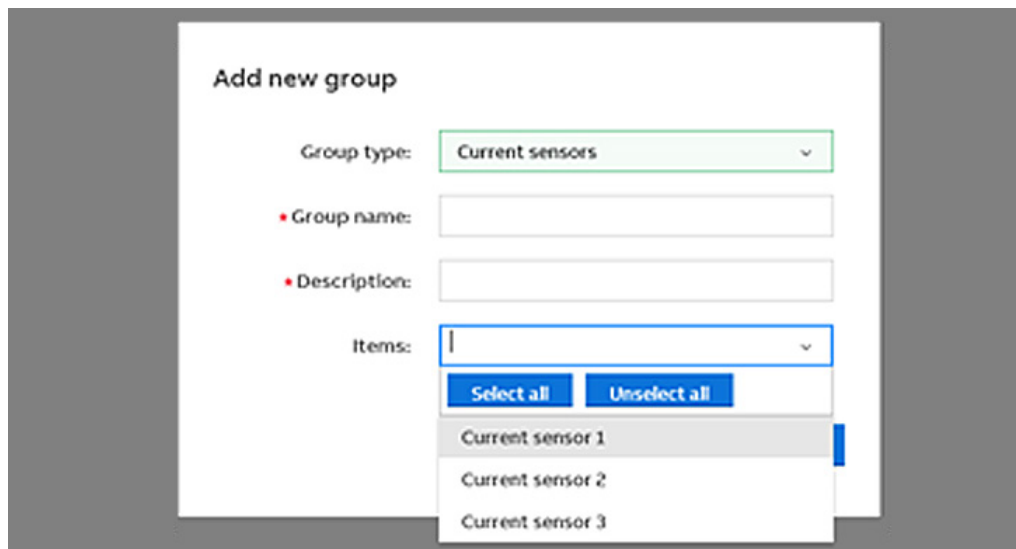



By clicking on the pencil icon “Edit” it is possible to edit all the fields of the selected group.

By clicking on x icon “Remove”, the selected group will be deleted.

ID	Type	Name	Description	Number of devices	Action
0	-	-	-	12	
1	Current sensors	Branches	All Current Sensors circuits 1-4	4	
2	Meters	EQmeters modbus	Meters of circuit 1-2-3	3	
3	I/O Modules	MCB status	Status open/closed of MCBs	4	

10.5.Tree view

This page allows to replicate the structure of the existing electrical network by designing a tree-view scheme between nodes.

The icon  identifies a virtual single node or sub-node while the icon  indicates a physical node.

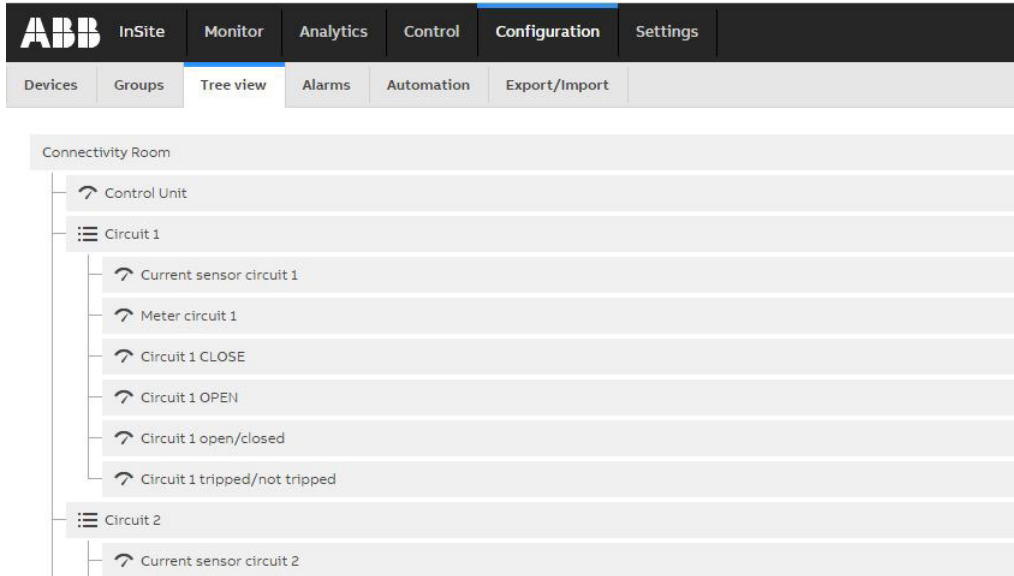

To create a virtual node click on the setting icon, click “add node”, select “node” from the dropdown menu and set the node name.

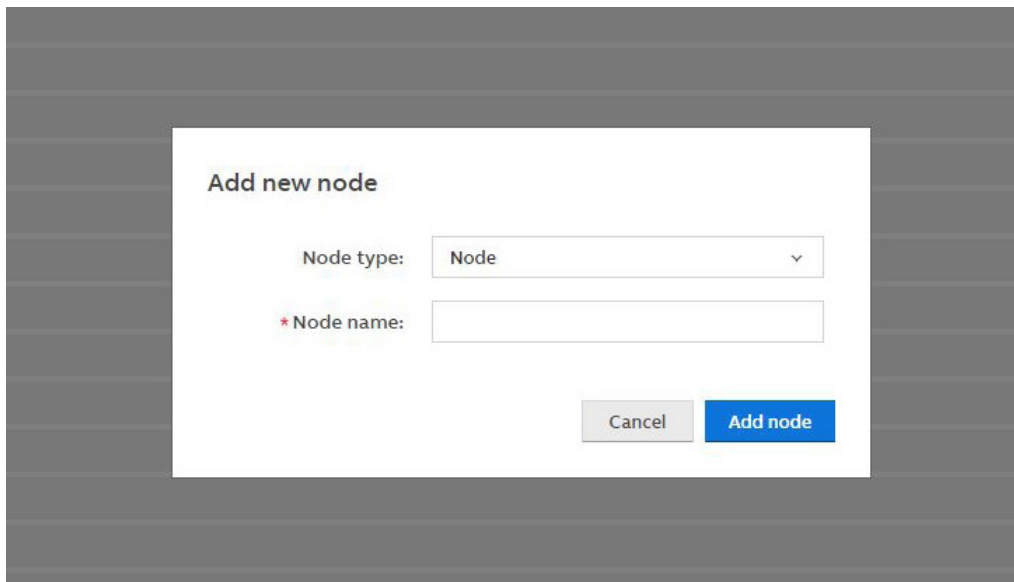

To create a physical node just click on the setting icon, click “add node”, select a node type from the dropdown menu (Current sensors, Meters or I/O Modules) and add the available item.



In the list are shown only devices already configured in “Configuration – Devices”.



Please note that it is possible to associate a device to a single group only.

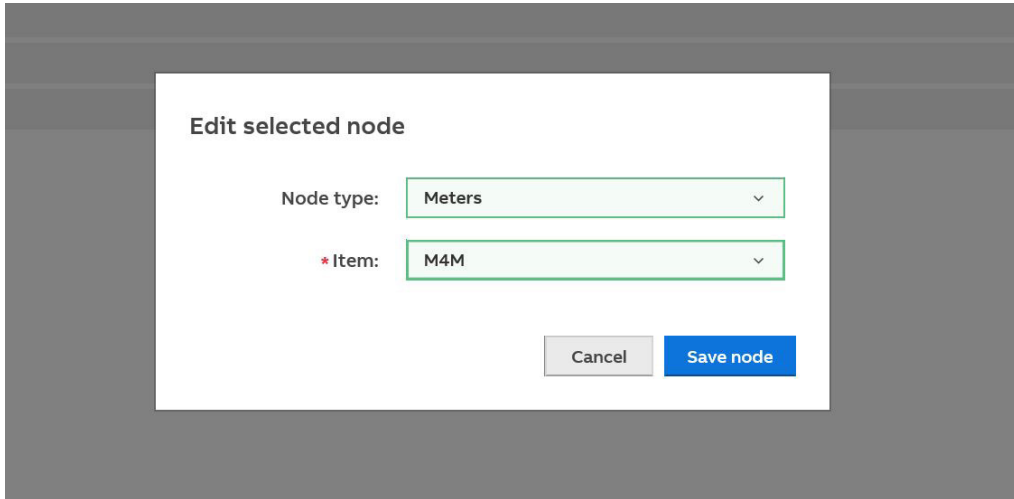

To edit or remove a single virtual or physical node just click on the setting icon and select the action. It is possible to modify the existing tree-view by dragging the selected virtual or physical node and replacing it in the new position inside the scheme.

10.6.Alarms

This page allows to set alarms. When a new device is added the alarms “Communication failure” and “Communication restore” are automatically configured in order to monitor the connection status for that device. If an alarm occurs, it is shown in the “Analytics – Alarms log” section. An alarm can occur after exceeding the selected threshold values (cross-up), after measuring values lower than the selected threshold values (cross-down) for a determined period (time delay) or if a certain status changes (status change). The email report is sent after 1 minute from the first event occurrence and consists of all alarms that occurred in this period. The next report can only be sent after at least 30 minutes since the first alarm occurrence and only in case event conditions are still ongoing.

If a SNMP trap is set up, a notification of the event will be sent.

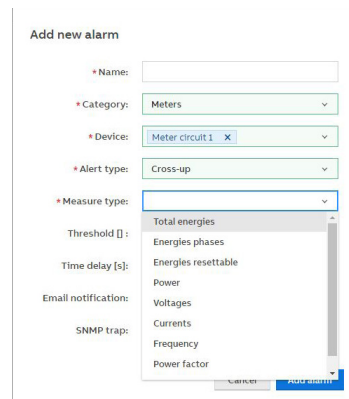
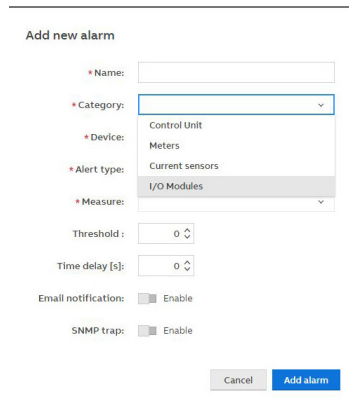
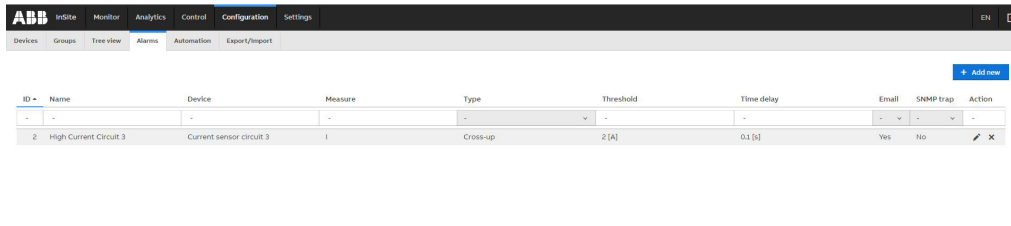

When adding or editing an alarm, please set the following:

Name	Set the name of the alarm
Category	Select the type of the device (Control unit, Meters, Current sensors, I/O Modules)
Device	Select the devices already defined in “Configuration – Devices” according to the Category selected
Alert Type	Type of alarm: “No event”, “Cross-up”, “Cross-down”, “Communication failure” and “Communication restore”. “Status change” only in case of I/O Modules devices
Measure	Set the specific measure to monitor according to the device selected
Threshold	Threshold of selected measure
Time delay	Define for how long the event criteria should be fulfilled in order to consider the occurrence as an event
Email notification	If the box is selected, an email will be sent when an alarm occurs. The email address has to be defined in “Settings – Email, FTP”.
SNMP trap	If the box is selected, notification of alarm will be sent via SNMP trap. SNMP trap settings have to be defined in “Settings – Communication / SNMP trap”

10.7.Automation

This page allows to set automatic actions on selected devices if a specific configured event occurs.

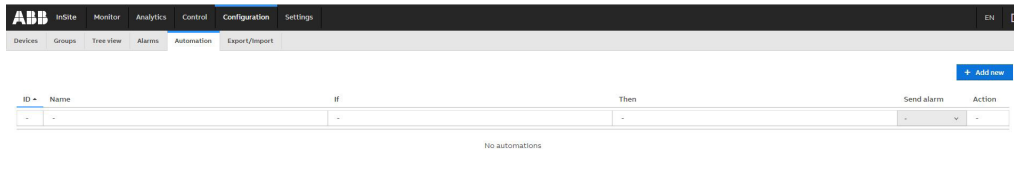

The automatic action can be set only for I/O Modules which have output channels already configured in “Configuration – Devices – I/O Modules”

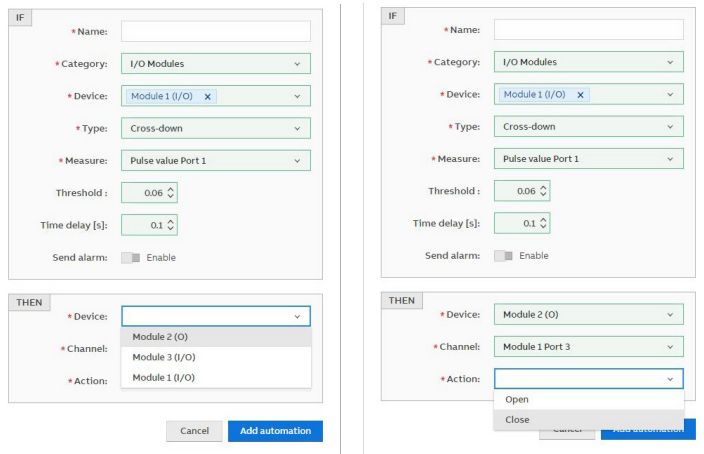

When adding or editing an automation, please set the following:

IF

Name	Set the name of the automation
Category	Select the type of the device
Device	Select the devices already defined in “Configuration – Devices” according to the Category selected
Alert Type	Type of alarm: “Cross-up”, “Cross-down”, “Communication failure” and “Communication restore”. “Status change” only in case of I/O Modules devices
Measure	Set the specific measure to monitor according to the device selected
Threshold	Threshold of selected measure
Time delay	Define for how long the event criteria should be fulfilled in order to consider the occurrence as an event
Send alarm	If the box is selected, then alarm will be shown in alarms log.

THEN

Device	Select the I/O Module with output channels already defined in “Configuration – Devices”
Channel	Select the output channel of the I/O Module already selected
Action	Set the action (open/close) to be performed by the channel if the condition previously configured occurs

10.8.Export/Import

Export

This page allows the export of complete settings of devices/groups/tree view and of historical values by checking the corresponding boxes and then clicking on “Download now”.

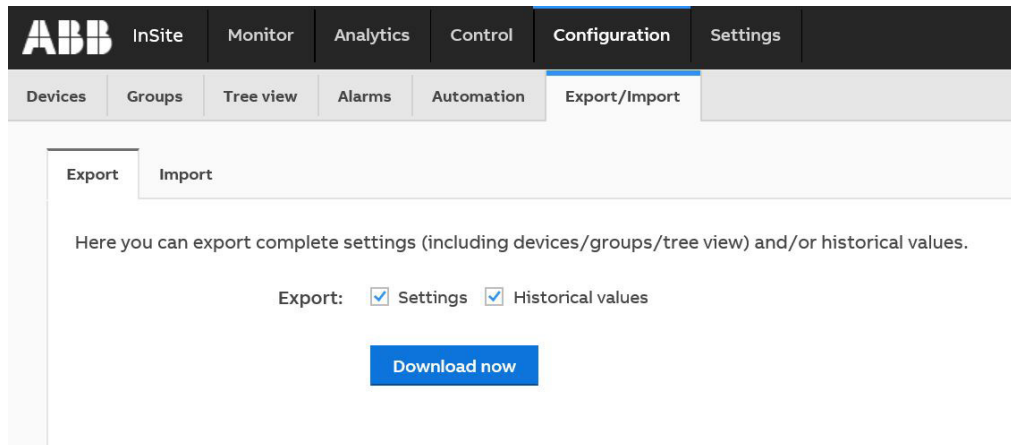

Import:

This page allows the import of settings and/or historical values. It is possible to choose to include or exclude devices/groups/tree view in the import. Before starting the import, clicking on “Import”, make sure the settings’ file you want to import has been drag and dropped in the corresponding “Drag and drop” window.

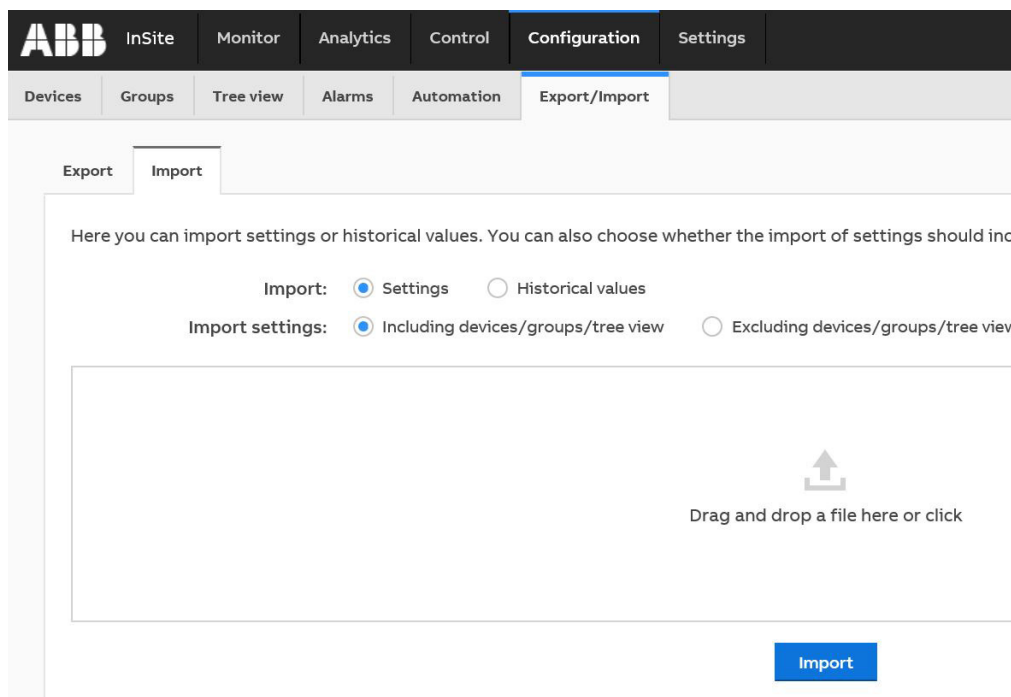

Importing settings from older firmware version with selected option “including devices” will clear all the devices, even if the tab did not exist in imported file. Then only settings existing in the imported file will be applied to the device.

11.WebUI - Settings

11.1.Users

This page allows the “Administrator” user to add new users, as “Operator” or “Guest”, by clicking on “Add new”: only the Administrator can add other users’ profiles. In order to remove users already created, select the user to be deleted and click on “Remove selected”.

The device can have only one single administrator.

The three different users’ profiles have the following rights:

Profiles	Administrator	Operator	Guest
Monitor	x	x	x (only visualization)
Analytics	x	x	partially (only visualization of historical values)
Control	x		
Configuration	x	partially (only devices, groups, tree view, alarms)	
Settings	x		

Clicking on “Add new”, a pop-up window appears:

The screenshot shows the ABB InSite Settings page. The main interface includes a navigation bar with 'Users', 'Email, FTP', 'Communication', 'SSL certificate', and 'General' tabs. Below the navigation is a table with columns for ID, Username, Role, and Action. The table contains one entry: ID '0', Username 'admin', Role 'Administrator'. A blue '+ Add new' button is in the top right. Below the table are two pop-up windows: 'Add new user' and 'Edit selected user'. The 'Add new user' window has fields for Username, Role (set to Operator), New password, and Confirm new password. The 'Edit selected user' window has fields for Username (admin), Role (Administrator), Current password, New password, and Confirm new password. Both windows have 'Cancel' and 'Add user'/'Save user' buttons.

By clicking on the pencil-icon, it is possible to edit the selected user, changing password and/or user name. While editing the sole administrator profile, it is required to insert the administrator current password.

11.2.Email - FTP

Email

Settings for contact details. Email and FTP settings are needed in order to carry out email and FTP data export. Please make sure that no firewall will block the export.

The screenshot shows the 'Settings' page in the ABB InSite interface. The 'Email, FTP' tab is selected, and the 'Email' sub-tab is active. The page contains the following fields and controls:

- Target email:** Text input field containing 'insite@abb.com'.
- Username:** Text input field containing 'commerciale.Negozio1'.
- Password:** Password input field with masked characters '*****'.
- SMTP server:** Text input field containing 'smtp.gmail.com'.
- SMTP port:** Spin box set to '465'.
- SSL connection:** Toggle switch set to 'Enable'.
- Email authentication:** Toggle switch set to 'Enable'.
- Buttons:** 'Apply' (blue) and 'Test' (grey) buttons.



Make sure communication on SMTP port 587 or 465 (SSL) is allowed in your network. Enter your FTP server details (address and login credentials) in order to allow automatic data export (measurement and/or events).

FTP

The screenshot shows the 'Settings' page in the ABB InSite interface. The 'Email, FTP' tab is selected, and the 'FTP' sub-tab is active. The page contains the following fields and controls:

- FTP server:** Text input field containing '-'.
- FTP directory:** Text input field.
- Protocol:** Dropdown menu.
- TCP Port:** Spin box set to '21'.
- Username:** Text input field containing '-'.
- Password:** Password input field with masked characters '*****'.
- Buttons:** 'Apply' (blue) and 'Test' (grey) buttons.

11.3.Communication

IP

The following information have to be set to correctly have access to the user interface via IP:

IP Mode	DHCP or static (Note: With DHCP you can find and define an IP address via the router by MAC address or device/host name - insite) The fallback IP address is: 192.168.1.200:8000
IP Address	Current IP address of device or possibility to define a new IP address
Subnet Mask	Current Subnet Mask or possibility to define another Subnet Mask
Gateway	Current Gateway or possibility to define another Gateway Address
DNS Server	Default: 8.8.8.8 or possibility to define another DNS Server
Host name	Insite or possibility to define another Host Name
MAC Address	Shows the MAC Address of the device
Apply	By clicking the Apply pushbutton changes are stored



Inappropriate settings may cause the user interface to become inaccessible. In order to be able to restore device access to the fallback IP, please use the reset button. (The device is visible when DHCP is active).

SNMP

To enable version 3 mark the v.3 checkbox, enter UDP port number (161 standard), authentication and privacy password (at least 8 signs), security name and engine ID (at least 12 characters in hexadecimal format). Port number must be 161 or greater than 1024 (the same as for versions v.1/2c).

Username and password perform the authentication needed to authenticate and encrypt the request to access data using SNMPv3. For the authentication the MD5 protocol is used and messages are additionally encrypted with the DES algorithm.

ABB InSite Monitor Analytics Control Configuration Settings insite EN

Users Email, FTP Communication SSL certificate General

IP SNMP SNMP trap Modbus VPN Rest API

Manage SNMP users, communities and access from this page. Use the checkbox to control the state of the SNMP agent, the permission for setting a request and the access for each of the protocols.

Protocols: v1/2c v3

[Download MIB file](#)

UDP Port: 161

* Authentication password (v3):

* Privacy password (v3):

* Security name (v3):

* Authoritative engine ID (v3):

Apply

SNMP trap

Manage SNMP trap settings. Remember to enable “SNMP trap” in “Configuration - Alarms”.

ABB InSite Monitor Analytics Control Configuration Settings EN

Users Email, FTP Communication SSL certificate General

IP SNMP SNMP trap Modbus Ethernet/IP

Manage SNMP trap settings. Remember to enable “SNMP trap” in “Alarms”.

Protocols: v2c v3 Disabled

Apply

Modbus

Here you can make changes to the MODBUS TCP and MODBUS RTU settings and download the .xlsx file of the register map associated to the firmware version onboard.

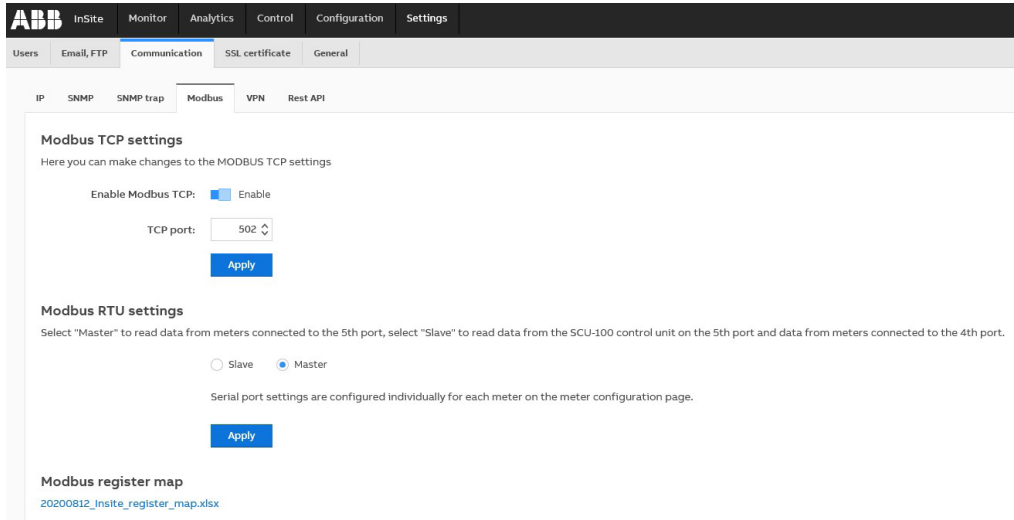

Modbus TCP settings	Enable Modbus TCP	Enable Modbus TCP communication
	TCP port	Configure TCP port (502 standard)
Modbus RTU settings	Modbus ID	Select Modbus ID
	Baud rate	Select baud rate
	Parity	Select parity setting: "None", "Odd" or "Even"

For MODBUS RTU select "Master" to read data from meters connected to the 5th port, select "Slave" to read data from the SCU-100 control unit on the 5th port and data from meters connected to the 4th port."

VPN

SCU100 can be connected to VPN network through VPN server. The Open VPN client version 2.4.7 is used “AS IS” without any modifications and as a standalone component. The source code can be downloaded here:

<https://swupdate.openvpn.org/community/releases/openvpn-2.4.7.tar.gz>

<https://github.com/OpenVPN/openvpn.git>

To enable the VPN client it is needed to upload the configuration file (.ovpn format) in the “VPN configuration” page area: it has to include information about IP address of VPN server, client certificate and key. If proxy server is used in the target network, its address should be included in the configuration file.

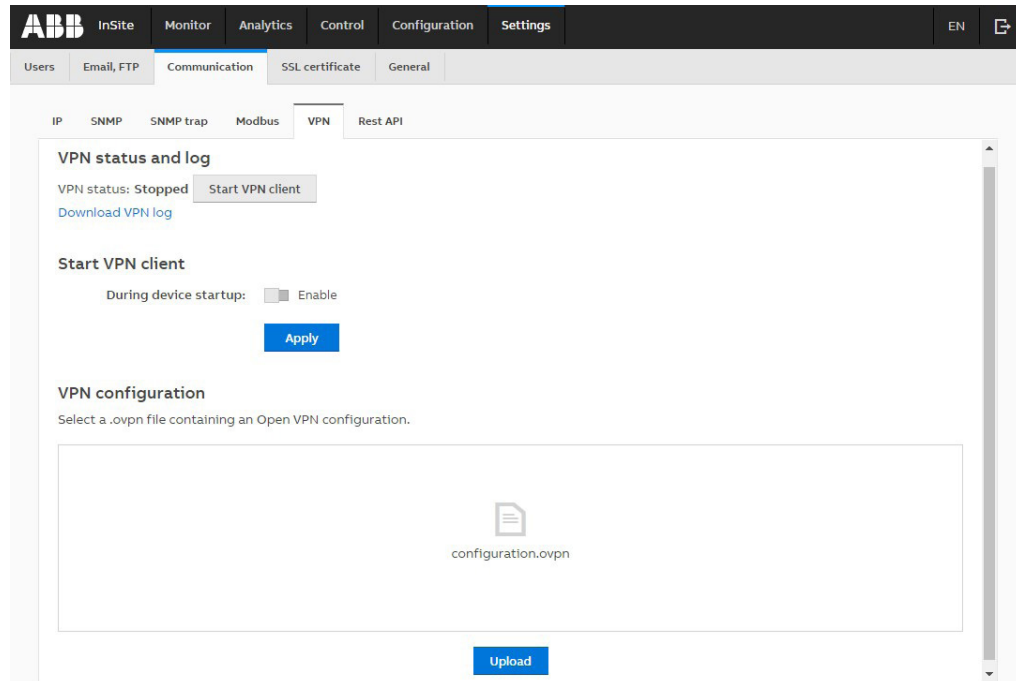

After uploading it, a connection to the VPN server can be initialized by pressing “Start VPN client” button. When the connection will be successful the status will change to Connected, otherwise debugging of the connection will be possible by downloading the VPN log file.

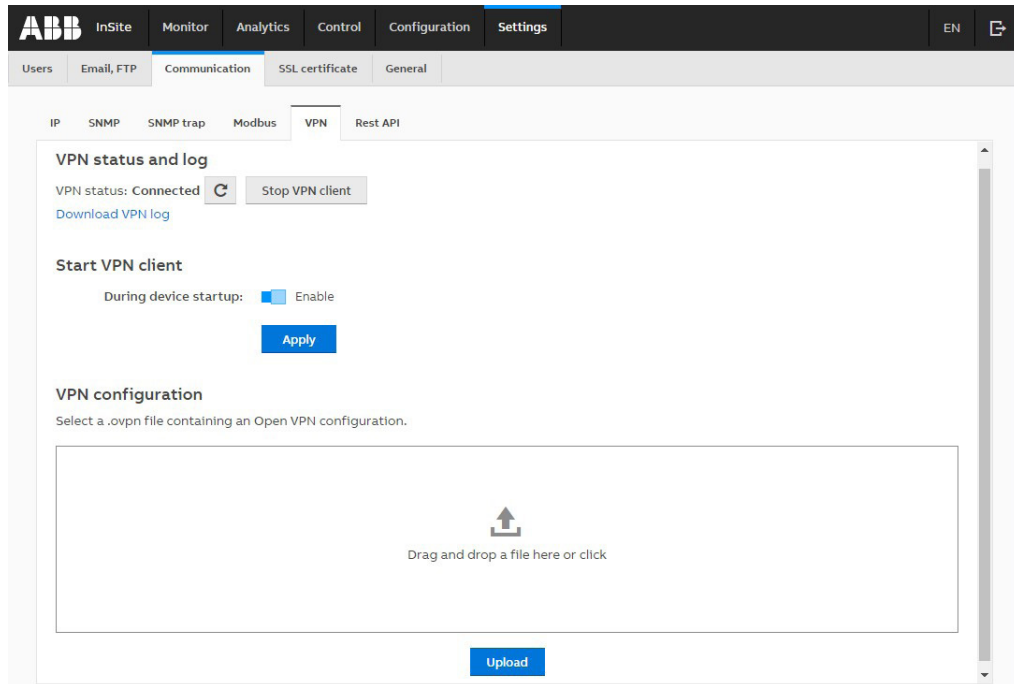

VPN client can be started automatically during device startup: to activate it, use “Start VPN client during device startup” option. The VPN client will start only if the configuration file was previously uploaded to the device.

Rest API

Rest API allows user to get online/historical values directly from Control Unit without accessing to the WebUI. It can be enabled by administrator in this section: to access data through Rest API an authorization token has to be provided in Authorization header in every request. The token has to be generated in this page.

The highest number that can be get properly via Rest API is $2^{53}-1$ (9007199254740991)

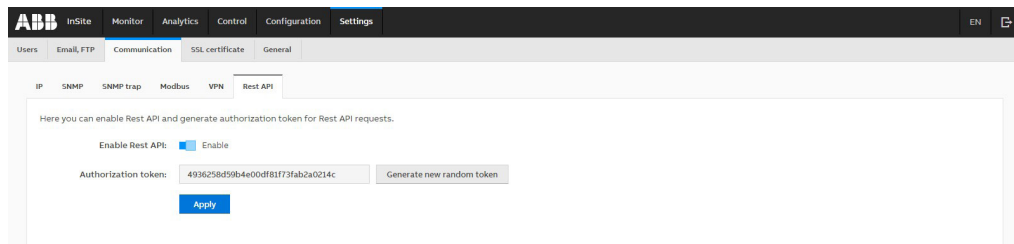

Available Rest Api endpoints:

GET: /api/gateway/systemInformation

Endpoint returns system information which can be used for diagnosis purpose. A request has to be sent with Authorization header e.g.:

Authorization: 4936258d59b4e00df81f73fab2a0214c

Response example:

```
{
  "ip": "192.168.1.200",
  "hostname": "insite",
  "softwareVersion": "1.1.0",
  "deviceTime": 1593173477,
  "voltageL1": 242.08
}
```

GET /api/gateway/metadata

Endpoint returns system devices metadata which contains all configured devices with available registers.
A request has to be sent

with Authorization header e.g.:

Authorization: 4936258d59b4e00df81f73fab2a0214c

JSON body reply:

```
{
  "ip": "192.168.1.200",
  "id": "insite",
  "modbus_rtu_devices": [
    {
      "modbus_id": 1,
      "name": "Meter 1",
      "registers": [
        {
          "cu_register_address": 37638,
          "description": "Active import L1",
          "data_type": "Unsigned integer",
          "size": 4,
          "byte_order": "Big-endian",
          "resolution": 30,
          "multiplier": 0.01,
          "rest_api_online": true,
          "rest_api_historical": true,
          "unit": "V"
        },
        {
          "cu_register_address": 37746,
          "description": "Active import total",
          "data_type": "Unsigned integer",
          "size": 2,
          "byte_order": "Big-endian",
          "resolution": 10,
          "multiplier": 0.1,
          "rest_api_online": true,
          "rest_api_historical": true,
          "unit": "V"
        }
      ]
    }
  ]
}
```

POST: /api/gateway/data

The endpoint allows to get data from control unit: available online and historical values can be read from the Insite_register_map.xlsx file in tabs SCU100 mains and sensors and SCU100 meters, IOs, system view. Variables are identified by Modbus register address and have to be provided in a JSON body of a POST request.

Below partial extracts of the .xlsx file as an example:

Addr (hex)	Addr (dec)	Words (16b)	Description	Resolutio	Unit	Format	Access	SNMP	RestApi online	RestApi historica
0000	0	1	TRMS value of Sensor 1	0.01	A	unsigned	R (03)	tRMSsens1	1	1
0001	1	1	TRMS value of Sensor 2	0.01	A	unsigned	R (03)	tRMSsens2	1	1
0002	2	1	TRMS value of Sensor 3	0.01	A	unsigned	R (03)	tRMSsens3	1	1
0003	3	1	TRMS value of Sensor 4	0.01	A	unsigned	R (03)	tRMSsens4	1	1
0004	4	1	TRMS value of Sensor 5	0.01	A	unsigned	R (03)	tRMSsens5	1	1
0005	5	1	TRMS value of Sensor 6	0.01	A	unsigned	R (03)	tRMSsens6	1	1
0006	6	1	TRMS value of Sensor 7	0.01	A	unsigned	R (03)	tRMSsens7	1	1
0007	7	1	TRMS value of Sensor 8	0.01	A	unsigned	R (03)	tRMSsens8	1	1
0008	8	1	TRMS value of Sensor 9	0.01	A	unsigned	R (03)	tRMSsens9	1	1
0009	9	1	TRMS value of Sensor 10	0.01	A	unsigned	R (03)	tRMSsens10	1	1
000A	10	1	TRMS value of Sensor 11	0.01	A	unsigned	R (03)	tRMSsens11	1	1
000B	11	1	TRMS value of Sensor 12	0.01	A	unsigned	R (03)	tRMSsens12	1	1
000C	12	1	TRMS value of Sensor 13	0.01	A	unsigned	R (03)	tRMSsens13	1	1
000D	13	1	TRMS value of Sensor 14	0.01	A	unsigned	R (03)	tRMSsens14	1	1
000E	14	1	TRMS value of Sensor 15	0.01	A	unsigned	R (03)	tRMSsens15	1	1
000F	15	1	TRMS value of Sensor 16	0.01	A	unsigned	R (03)	tRMSsens16	1	1
0010	16	1	TRMS value of Sensor 17	0.01	A	unsigned	R (03)	tRMSsens17	1	1
0011	17	1	TRMS value of Sensor 18	0.01	A	unsigned	R (03)	tRMSsens18	1	1
0012	18	1	TRMS value of Sensor 19	0.01	A	unsigned	R (03)	tRMSsens19	1	1
0013	19	1	TRMS value of Sensor 20	0.01	A	unsigned	R (03)	tRMSsens20	1	1
0014	20	1	TRMS value of Sensor 21	0.01	A	unsigned	R (03)	tRMSsens21	1	1
0015	21	1	TRMS value of Sensor 22	0.01	A	unsigned	R (03)	tRMSsens22	1	1
0016	22	1	TRMS value of Sensor 23	0.01	A	unsigned	R (03)	tRMSsens23	1	1
0017	23	1	TRMS value of Sensor 24	0.01	A	unsigned	R (03)	tRMSsens24	1	1
0018	24	1	TRMS value of Sensor 25	0.01	A	unsigned	R (03)	tRMSsens25	1	1
0019	25	1	TRMS value of Sensor 26	0.01	A	unsigned	R (03)	tRMSsens26	1	1
001A	26	1	TRMS value of Sensor 27	0.01	A	unsigned	R (03)	tRMSsens27	1	1
001B	27	1	TRMS value of Sensor 28	0.01	A	unsigned	R (03)	tRMSsens28	1	1
001C	28	1	TRMS value of Sensor 29	0.01	A	unsigned	R (03)	tRMSsens29	1	1
001D	29	1	TRMS value of Sensor 30	0.01	A	unsigned	R (03)	tRMSsens30	1	1
001E	30	1	TRMS value of Sensor 31	0.01	A	unsigned	R (03)	tRMSsens31	1	1
001F	31	1	TRMS value of Sensor 32	0.01	A	unsigned	R (03)	tRMSsens32	1	1
0020	32	1	TRMS value of Sensor 33	0.01	A	unsigned	R (03)	tRMSsens33	1	1
0021	33	1	TRMS value of Sensor 34	0.01	A	unsigned	R (03)	tRMSsens34	1	1
0022	34	1	TRMS value of Sensor 35	0.01	A	unsigned	R (03)	tRMSsens35	1	1
0023	35	1	TRMS value of Sensor 36	0.01	A	unsigned	R (03)	tRMSsens36	1	1
0024	36	1	TRMS value of Sensor 37	0.01	A	unsigned	R (03)	tRMSsens37	1	1

External Modbus address	Slave Modbus ID	External Modbus data type	Writable	Category	Quantity	Registers	SNMP	RestApi online	RestApi historical
37062	1	Unsigned integer	0	Energies Ph/Tarri	Active import L1..L3, tar 1..8	96	activeImportL1L3tar18id1	1	0
37158	1	Unsigned integer	0	Energies Ph/Tarri	Active export L1..L3, tar 1..8	96	activeExportL1L3tar18id1	1	0
37254	1	Unsigned integer	0	Energies Ph/Tarri	Reactive import L1..L3, tar 1..8	96	reactiveImportL1L3tar18id1	1	0
37350	1	Unsigned integer	0	Energies Ph/Tarri	Reactive export L1..L3, tar 1..8	96	reactiveExportL1L3tar18id1	1	0
37446	1	Unsigned integer	0	Energies Ph/Tarri	Apparent import L1..L3, tar 1..8	96	apparentImportL1L3tar18id1	1	0
37542	1	Unsigned integer	0	Energies Ph/Tarri	Apparent export L1..L3, tar 1..8	96	apparentExportL1L3tar18id1	1	0
37638	1	Unsigned integer	0	Energies phases	Active import L1	4	activeImportL1id1	1	1
37642	1	Unsigned integer	0	Energies phases	Active import L2	4	activeImportL2id1	1	1
37646	1	Unsigned integer	0	Energies phases	Active import L3	4	activeImportL3id1	1	1
37650	1	Unsigned integer	0	Energies phases	Active export L1	4	activeExportL1id1	1	1
37654	1	Unsigned integer	0	Energies phases	Active export L2	4	activeExportL2id1	1	1
37658	1	Unsigned integer	0	Energies phases	Active export L3	4	activeExportL3id1	1	1
37662	1	Signed integer (IM300: unsigned)	0	Energies phases	Active net L1	4	activeNetL1id1	1	1
37666	1	Signed integer (IM300: unsigned)	0	Energies phases	Active net L2	4	activeNetL2id1	1	1
37670	1	Signed integer (IM300: unsigned)	0	Energies phases	Active net L3	4	activeNetL3id1	1	1
37674	1	Unsigned integer	0	Energies phases	Reactive import L1	4	reactiveImportL1id1	1	1
37678	1	Unsigned integer	0	Energies phases	Reactive import L2	4	reactiveImportL2id1	1	1
37682	1	Unsigned integer	0	Energies phases	Reactive import L3	4	reactiveImportL3id1	1	1
37686	1	Unsigned integer	0	Energies phases	Reactive export L1	4	reactiveExportL1id1	1	1
37690	1	Unsigned integer	0	Energies phases	Reactive export L2	4	reactiveExportL2id1	1	1
37694	1	Unsigned integer	0	Energies phases	Reactive export L3	4	reactiveExportL3id1	1	1
37698	1	Signed integer (IM300: unsigned)	0	Energies phases	Reactive net L1	4	reactiveNetL1id1	1	1
37702	1	Signed integer (IM300: unsigned)	0	Energies phases	Reactive net L2	4	reactiveNetL2id1	1	1
37706	1	Signed integer (IM300: unsigned)	0	Energies phases	Reactive net L3	4	reactiveNetL3id1	1	1
37710	1	Unsigned integer	0	Energies phases	Apparent import L1	4	apparentImportL1id1	1	1
37714	1	Unsigned integer	0	Energies phases	Apparent import L2	4	apparentImportL2id1	1	1
37718	1	Unsigned integer	0	Energies phases	Apparent import L3	4	apparentImportL3id1	1	1
37722	1	Unsigned integer	0	Energies phases	Apparent export L1	4	apparentExportL1id1	1	1
37726	1	Unsigned integer	0	Energies phases	Apparent export L2	4	apparentExportL2id1	1	1
37730	1	Unsigned integer	0	Energies phases	Apparent export L3	4	apparentExportL3id1	1	1
37734	1	Signed integer	0	Energies phases	Apparent net L1	4	apparentNetL1id1	1	1
37738	1	Signed integer	0	Energies phases	Apparent net L2	4	apparentNetL2id1	1	1
37742	1	Signed integer	0	Energies phases	Apparent net L3	4	apparentNetL3id1	1	1
37746	1	Unsigned integer	0	Energies Resettable	Active import total	4	activeImportTotalid1	1	0
37750	1	Unsigned integer	0	Energies Resettable	Active export total	4	activeExportTotalid1	1	0
37754	1	Unsigned integer	0	Energies Resettable	Reactive import total	4	reactiveImportTotalid1	1	0

Following variables have to be provided in the JSON body:

- “data”: list of objects with identifiers for requested data. The data object has to include:
 - “addresses”: list of Modbus addresses for requested control unit variables
 - “type”: data type (“online” or “historical”). If historical data is selected then “begin_timestamp” and “end_timestamp” have to be provided.

As the reply returned is JSON with following variables:

- “ip”: IP address of the control unit
- “id”: the hostname of the control unit
- “data”: list of objects with available control unit data. Each object has “timestamp” and “values” identifiers. For online data returned is single object with current timestamp. For historical data returned is a list of objects with timestamps available for selected time range. In the “value” provided are available registers and values.

Examples**Reading online data**

Authorization header: 4936258d59b4e00df81f73fab2a0214c

JSON body request:

```
{
  "data": [
    {
      "protocol": "rtu",
      "addresses": [36866, 36868],
      "type": "online"
    }
  ]
}
```

JSON body reply:

```
{
  "ip": "192.168.1.200",
  "id": "insite",
  "data": [
    {
      "timestamp": 1593174314,
      "values": {
        "36866": 242.32,
        "36868": 241.68
      }
    }
  ]
}
```

Reading historical data

Authorization header: 4936258d59b4e00df81f73fab2a0214c

JSON body request:

```
{
  "data": [
    {
      "protocol": "rtu",
      "addresses": [36866],
      "type": "historical",
      "begin_timestamp": 1593174621,
      "end_timestamp": 1593174721
    }
  ]
}
```

JSON body reply:

```
{
  "ip": "192.168.1.200",
  "id": "insite",
  "data": [
    {
      "timestamp": 1593174720,
      "values": {
        "36866": 242.16
      }
    },
    {
      "timestamp": 1593174710,
      "values": {
        "36866": 242.14
      }
    }
  ]
}
```

Mixed request for online and historical data

Requested data can be mixed (online with historical or multiple historical time ranges) e.g:

```
{
  "data": [
    {
      "_comment": "Query multiple registers for online data",
      "protocol": "rtu",
      "addresses": [36866, 36868],
      "type": "online"
    },
    {
      "_comment": "Query multiple registers for historical data",
      "protocol": "rtu",
      "addresses": [36866, 36868],
      "type": "historical",
      "begin_timestamp": 1593586022,
      "end_timestamp": 1593589022
    },
    {
      "_comment": "Query for other time range",
      "protocol": "rtu",
      "addresses": [36866, 36868],
      "type": "historical",
      "begin_timestamp": 1594023345,
      "end_timestamp": 1594022345
    }
  ]
}
```

JSON body reply:

```
{
  "ip": "10.3.101.49"
  "id": "insite",
  "data": [
    {
      "timestamp": 1594022797,
      "values": {
        "36866": 234.56,
        "36868": 234.82
      }
    },
    {
      "timestamp": 1593588600,
      "values": {
        "36866": 233.86,
        "36868": 234.1
      }
    },
    {
      "timestamp": 1593587700,
      "values": {
        "36866": 234.06,
        "36868": 234.31
      }
    },
    {
      "timestamp": 1593586800,
      "values": {
        "36866": 233.93,
        "36868": 234.18
      }
    }
  ]
}
```

Cloud gateway client

SCU100 can be connected to cloud gateway client. To enable the cloud gateway client is needed to upload the certificate files, in the “Client configuration” page area: it has to include information about port and host, cloud gateway certificate, client certificate and key.

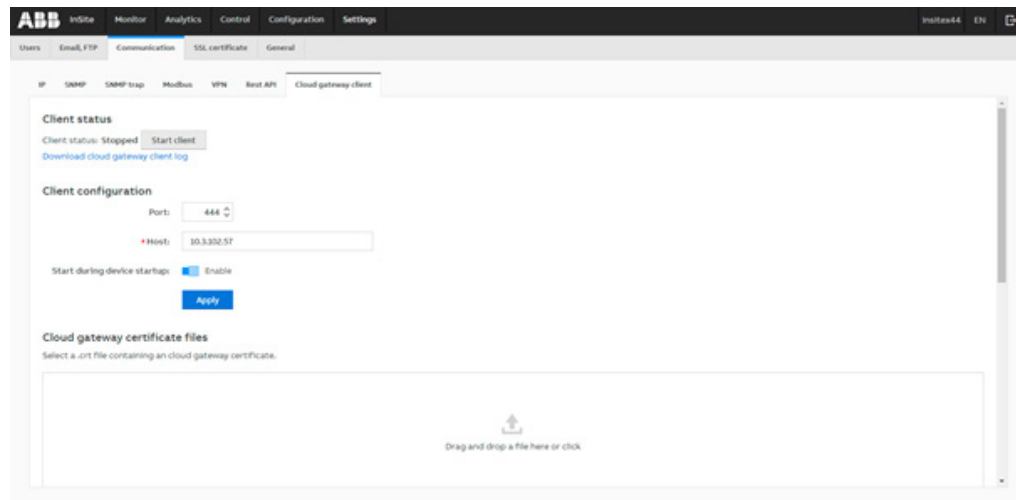

After uploading it, a connection to the cloud gateway client can be initialized by pressing “Start client” button.

When the connection will be successful the status will change to Authorized, otherwise debugging of the connection will be possible by downloading the cloud gateway client log file.

It is possible to connect multiple SCU100 to same cloud gateway client. Each SCU100 should have a unique hostname.

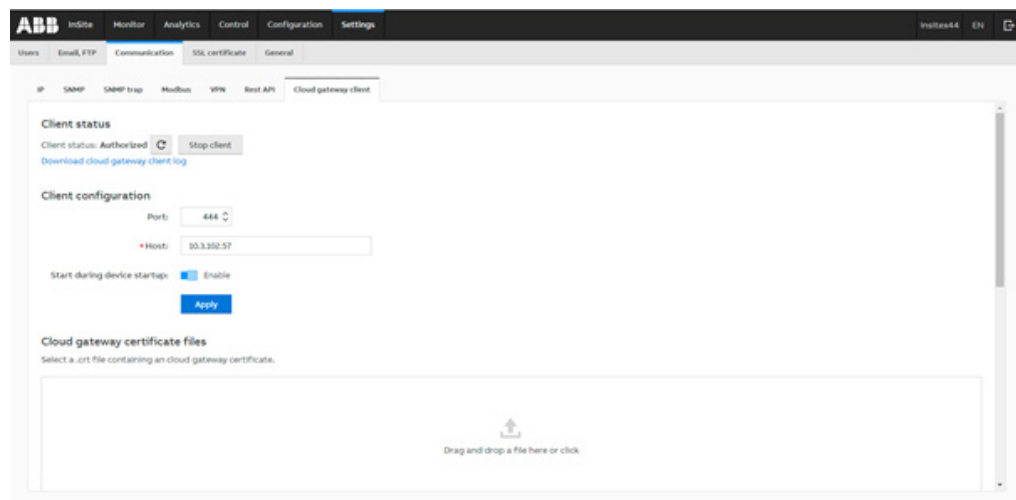

Cloud gateway client can be started automatically during device startup: to activate it, use “Start during device startup” option. The cloud gateway client will start only if the configuration files were previously uploaded to the device.

11.4.SSL certificate

In this section it is possible to upload or generate a .pem file containing a private key and a public certificate in order to provide a secure connection via the web browser.

Upload

It is possible to browse, upload or download the currently in place certificate.

For this purpose, please drag and drop the .pem file to the browser or click to browse, then push the upload button and wait for the uploading to finish. After a successful uploading process, the web server reboots.

It is also possible to download a currently used certificate by clicking download certificate.

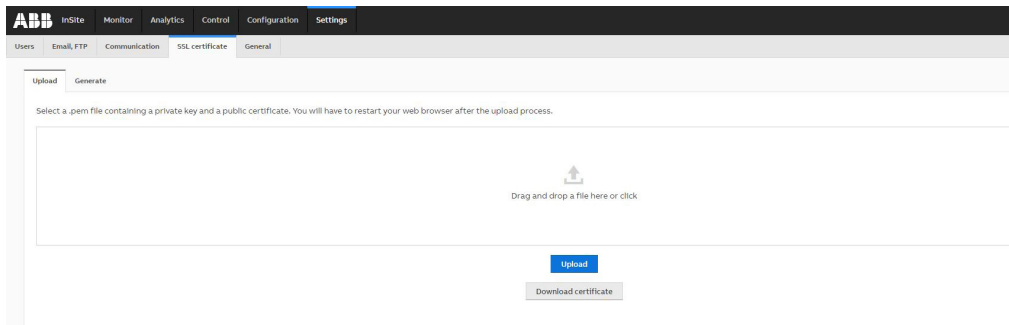

Generate

In order to generate a SSL certificate, following configurations must be considered:

IP address	Indicates your currently configured IP address on the device
Subnet mask	Indicates your currently configured subnet mask on the device
Gateway	Indicates your currently configured gateway on the device
Select whole subnet	If checked, you can generate a certificate for the whole subnet. The minimal subnet mask is 255.255.252.0.
Domain / IP	You can manually type in IP addresses and insert them to the table with the Add button

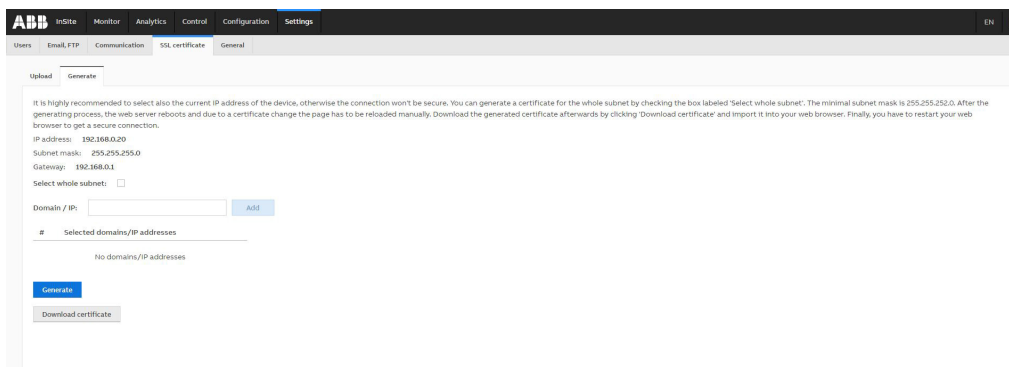

After configuration of domains/IP addresses table, please click the Generate button. When the generating process finishes, the web server reboots and due to a certificate change the page has to be reloaded manually.

Follow the passages reported below to import the downloaded certificate into your web browser.

Certificate Import Wizard

INTERNET EXPLORER (Windows 10 only)

1. Open Internet options
2. Choose Content tab and then Certificates one
3. Select Trusted Root Certification Authorities and then select Import

GOOGLE CHROME

1. Open Settings
2. Scroll down to open Advanced
3. Click Manage Certificates and choose Trusted Root Certification Authorities and then select Import

It is necessary at first to open the Certificate Import Wizard according to the browser you are using and then to install the certificate.

11.5.General

Time

The screenshot shows the ABB InSite web interface. The top navigation bar includes 'ABB', 'InSite', 'Monitor', 'Analytics', 'Control', 'Configuration', and 'Settings'. Below this, there are tabs for 'Users', 'Email, FTP', 'Communication', 'SSL certificate', and 'General'. The 'General' tab is active, and within it, the 'Time' sub-tab is selected. The 'Time settings' section contains a 'Web browser time' field (15/1/2020, 12:24:22) and a 'Device time' field (15/1/2020, 12:24:21), with a 'Synchronize' button below. The 'Set time manually' section has a 'Set time' field with a date picker (15/1/2020) and a time picker (12:24:08), with an 'Apply' button below. The 'NTP' section has an 'NTP' checkbox (checked), a 'Time server 1' field (pool.ntp.org), and a 'Time server 2' field, with an 'Apply' button below.

• Time settings

It is possible to synchronize the time to compare the time of the device and the one on the web browser. The synchronization is mandatory in order to correctly visualize and store data.

By clicking on “Synchronize” button, the Control Unit will synchronize with the web browser time.

Please note: if device time differs by more than 10min from the web browser time, a warning message will be shown.

• Set time manually

It is also possible to manually set the time. Please select date and time using calendar and clock icons.

• NTP

If an NTP Server is available you can set the IP address (Time Server 1, Time Server 2) for automatic time synchronization. In this case, the synchronization procedure can take up to 10 minutes.

Please make sure that no firewall will block the NTP server.



Check the internal time of the device in order to guarantee correct operation of the SCU100. If it is not correct, it has to be set manually.

Please keep attention: incorrect date and time settings may cause device malfunction.

Session

This page allows to change the logged user session timeout.

Select the desired session timeout from the dropdown list and then click “Apply” to save the changes.

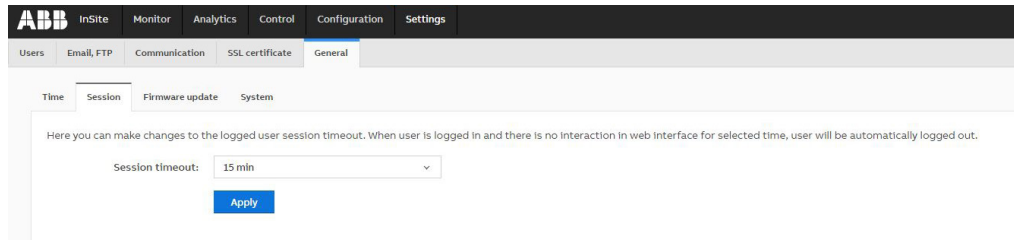

Firmware update

Using this menu you can update the firmware of the control unit.

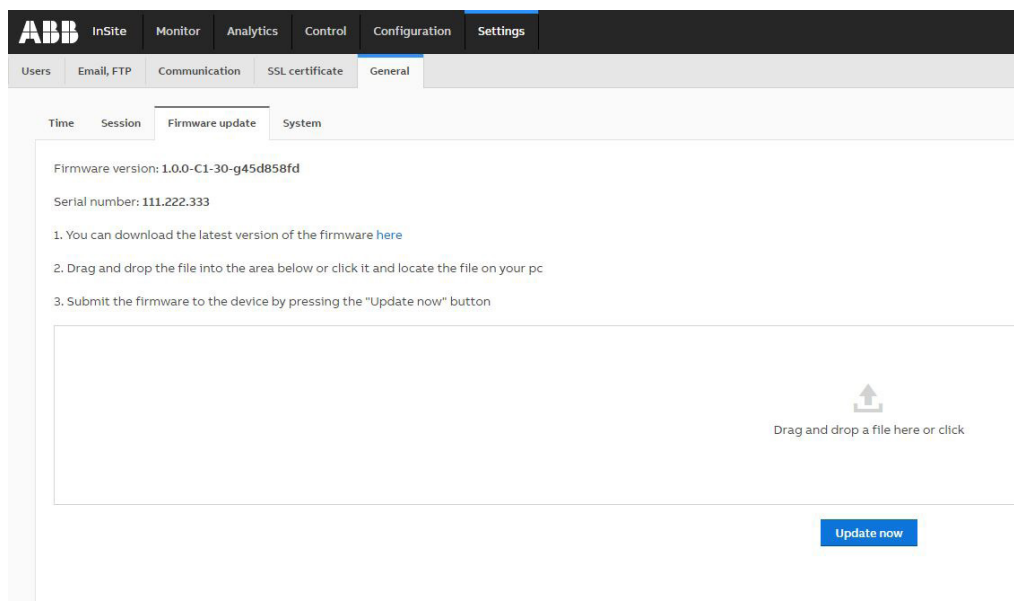

It is highly recommended to update the firmware to the latest version for security and functionality reasons. Please check the ABB website for current SW revision and to download the latest version of the firmware.

After browsing the downloaded file, please use the “Update file” button to submit the new firmware to the device. In addition, you can find the installed firmware version and the serial number of the device at the bottom of the web page.

System

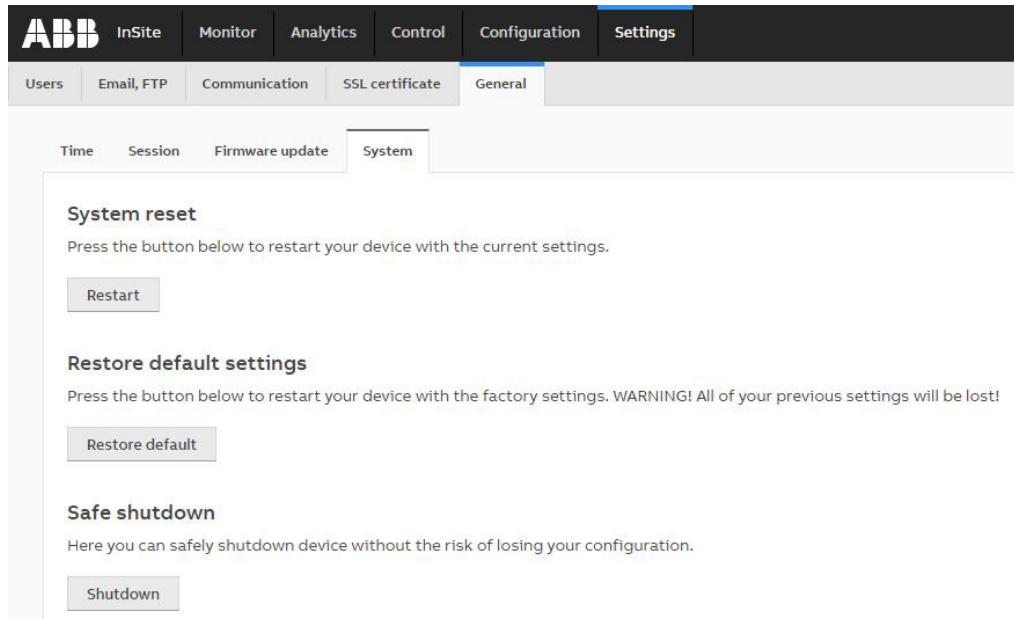

The screenshot shows the ABB InSite web interface. The top navigation bar includes the ABB logo and tabs for InSite, Monitor, Analytics, Control, Configuration, and Settings. Below this, a secondary navigation bar contains tabs for Users, Email, FTP, Communication, SSL certificate, and General. The main content area has tabs for Time, Session, Firmware update, and System. The System tab is active, displaying three sections: System reset, Restore default settings, and Safe shutdown. Each section includes a brief instruction and a corresponding button.

System reset
Press the button below to restart your device with the current settings.

Restart

Restore default settings
Press the button below to restart your device with the factory settings. WARNING! All of your previous settings will be lost!

Restore default

Safe shutdown
Here you can safely shutdown device without the risk of losing your configuration.

Shutdown

In this section it is possible to carry out a system reset (to restart the device with the current settings), to restore the default settings and to carry out a safe shutdown. After any change in the settings we recommend you to do a safe shutdown. To do so, push the “Shutdown” button. If the Status LED is shining green without flashing, and if the network LED is out, you can turn off the power supply. For starting the device, turn on the power supply. The SCU100 will automatically start.

12.WebUI – Monitor

12.1.Dashboard

“In the Dashboard section it is possible to create and customize different dashboards in order to have an immediate and easily visible summary of the desired set of measurement data and system information.

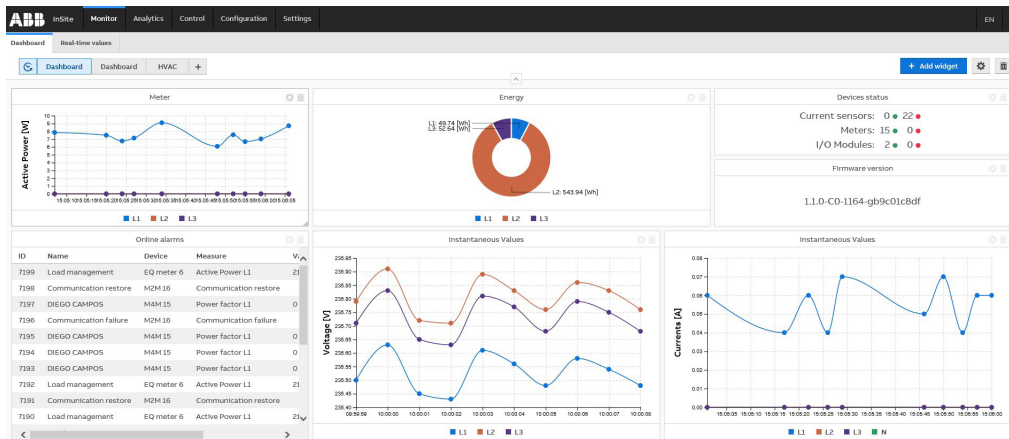

It's possible to create up to 5 different dashboards: to create a new one click on “+” button aside the dashboard tabs, define a name and select the size (“Auto” or “Custom”). In every moment it is possible to change the size parameters (number and dimensions of columns and rows) by selecting the desired dashboard and clicking on the setting icon on the right side of the screen. To delete it click on the bin icon.

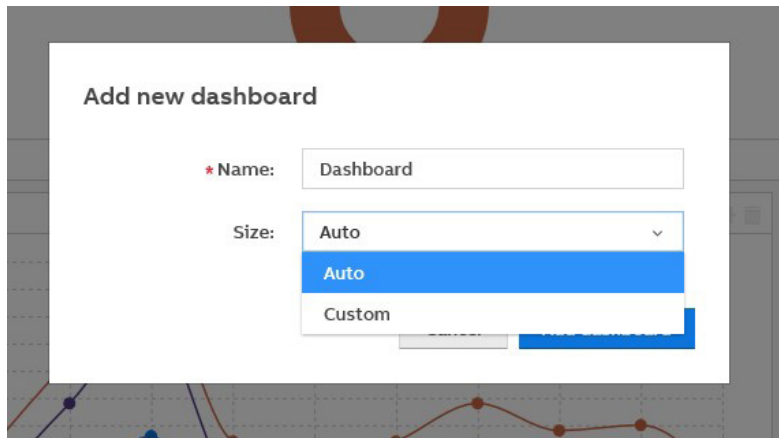

The dashboard interface is based on pre-defined widget logic. To add a new widget to the dashboard click on “Add widget”.

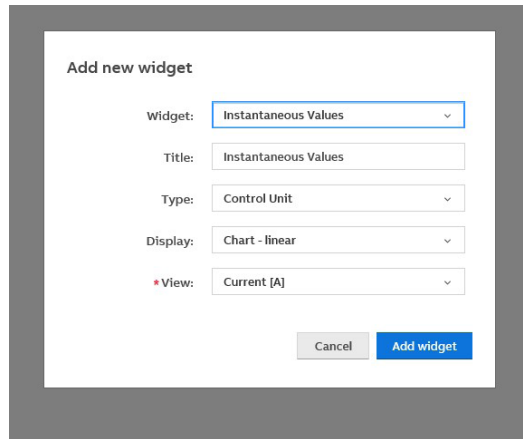

Buttons	
Add	
Widget	Select the widget among pre-defined categories: “Instantaneous Values”, “Device status”, “Energy”, “Alarms log”, “Device time” and “Firmware version”
Title	Type the title of the widget
Type	Select the source of information (device type)
Display	Select the way to display data: “Chart – linear” or “Table”
View	Select the parameter to be displayed

Once the widget has been created it is possible to move it to the desired area of the dashboard and modify its size.”

12.2.Real-time values

Control Unit

The “Real-time Values” section shows all measured values by control unit reporting the trend of the last 10s.

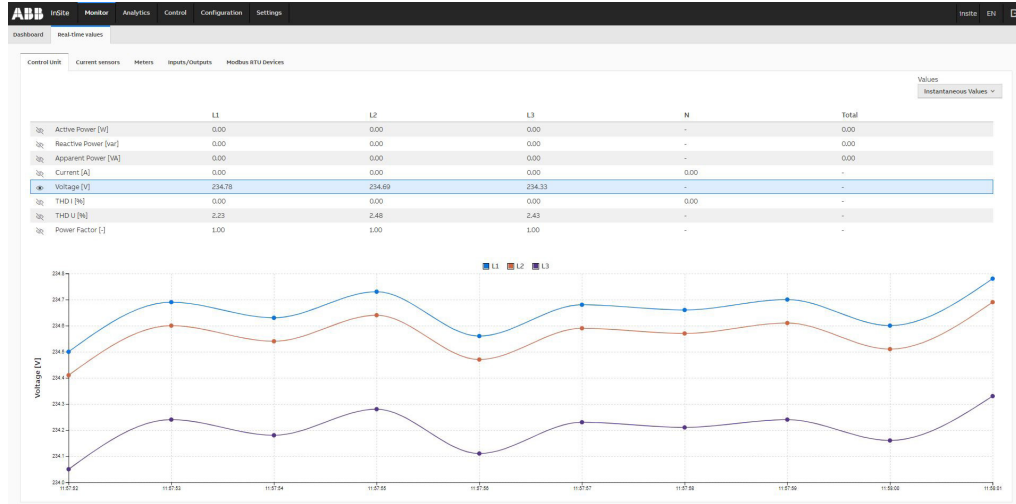

If no graph is visible, it is necessary to synchronize the device time with the “Set time manually” button in the Settings – General / Time menu.

Current sensors

Here it is possible to visualize “Real-time values” for the current sensors.

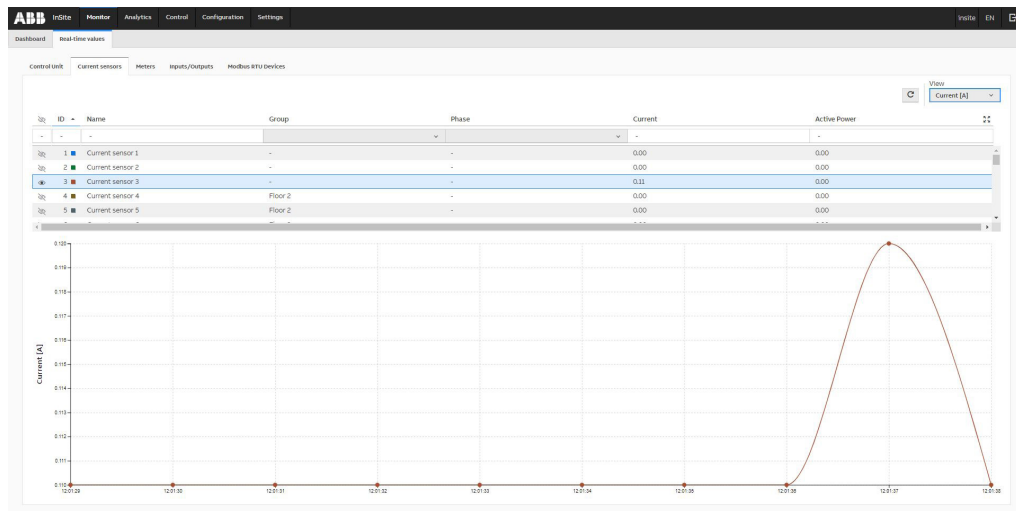

Sensors have to be first assigned and configured (please refer to Configuration - Devices – Current sensors).



In case of DC sensor measurement, please refer to “Configuration - Devices – Current sensors” and configure “Phase” as DC and voltage setting in “Configuration-Devices-Control Unit”. Accordingly, when “DC” is displayed under “Phase”, DC current and active power are displayed on this page.

Meters

Here it is possible to visualize “Real-time values” for the meters.

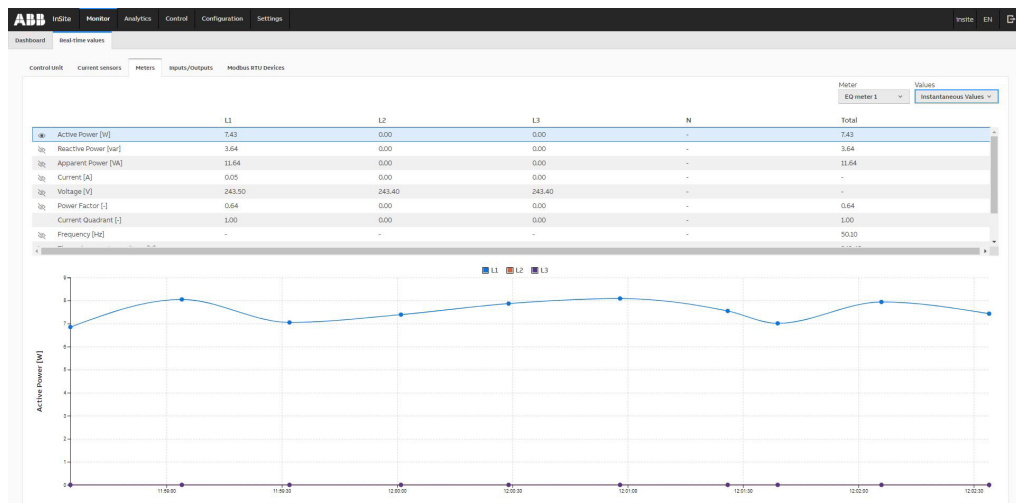

In the “Values” dropdown list it is possible to select the parameters accordingly with the “Meter” selected. Available values showed are: “Energy values”, “Instantaneous Values”, “Power Quality Values”, “Harmonics”, “Maximum Values”.

Inputs/Outputs

Here it is possible to visualize “Real-time values” for each digital channel of the I/O modules and connected meters. “Real-time values” are “Status” and “Counter”.

Meter slave ID	Port no.	Channel tag name	Channel type	Device type	Status	Counter	Pulse value	Pulse unit	Action
7	3	EQ meter 7 Port 3	Auxiliary contact	S2C-HBR	Open	1	-	-	Reset
7	4	EQ meter 7 Port 4	Pulse	Gas	Open	1	1	m3	Reset
8	3	EQ meter 8 Port 3	Signal contact	S2C-S/HBR	-	-	-	-	-
8	4	EQ meter 8 Port 4	-	-	-	-	-	-	-
9	3	EQ meter 9 Port 3	-	-	Open	1	-	-	Reset
9	4	EQ meter 9 Port 4	-	-	Open	1	-	-	Reset
10	3	EQ meter 10 Port 3	-	-	Open	1	-	-	Reset
10	4	EQ meter 10 Port 4	-	-	Open	1	-	-	Reset
11	3	EQ meter 11 Port 3	-	-	Open	1	-	-	Reset
11	4	EQ meter 11 Port 4	-	-	Open	1	-	-	Reset
12	3	EQ meter 12 Port 3	-	-	Open	1	-	-	Reset
12	4	EQ meter 12 Port 4	-	-	Open	1	-	-	Reset
13	3	EQ meter 13 Port 3	-	-	Open	1	-	-	Reset
13	4	EQ meter 13 Port 4	-	-	Open	1	-	-	Reset
14	3	EQ meter 14 Port 3	Pulse	Water	Open	1	1	L	Reset
14	4	EQ meter 14 Port 4	Auxiliary contact	S2C-S/HBR	Open	1	-	-	Reset
15	1	MM 15 Port 1	-	-	-	-	-	-	-



Only Administrator and Operator users are allowed to perform Reset of the counters

To monitor meter ports to InSite via Modbus, read registers with following description:

- “Output X” (X – port number 1-4) – values 1/0 – on/off
- “Input Current State X” (X – port number 1-4) – values 1/0 – on/off
- “Input X Counter” (X – port number 1-4) – 4 registers = unit64 little endian byte swap

Modbus RTU Devices

In the “Values” dropdown list it is possible to select the parameters accordingly with the “ Modbus RTU Device” selected. Available values showed are: “Energy values”, “Instantaneous Values”, “Power Quality Values”, “Harmonics”, “Maximum Values”, “Custom”

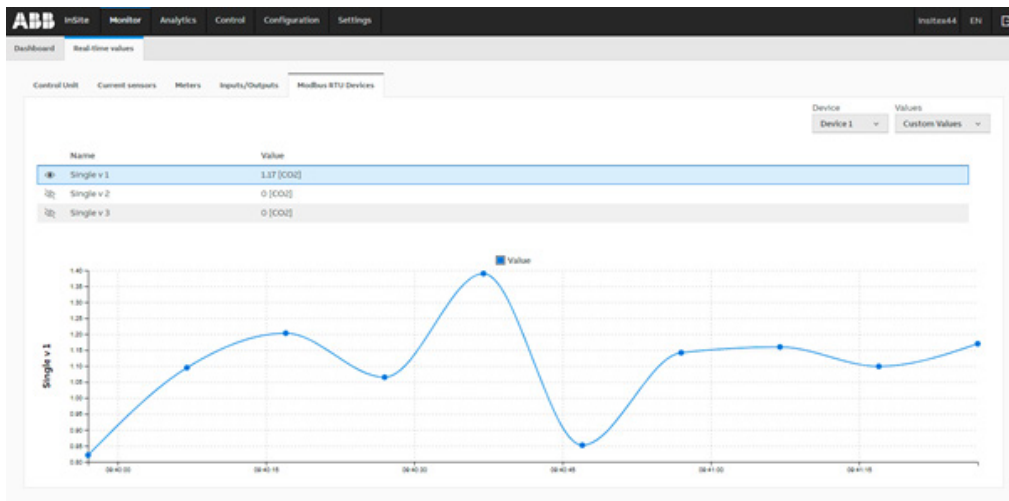

13.WebUI – Analytics

13.1.Historical values

Here it is possible to visualize the “Historical values” of different measurements according to the category or group selected.

Data resolution depends on the device and it binds the maximum time interval that can be shown. For I/O Modules it is possible to show pulses or “Counter” and “Status” of input/output channels.

Data resolution	
Control unit	10 seconds, Quarter, Hour, Day and Week
Current sensors	10 seconds, Quarter, Hour, Day and Week
Meters	30 seconds (according to type of measurement), Quarter, Hour, Day
I/O Modules	Last 1000 events
Modbus RTU devices	10/30/900 seconds (according to type of measurement), Quarter, Hour, Day



All the devices have to be first assigned and configured (please refer to Configuration → Devices).



In case of DC current sensors measurement, please refer to “Configuration → Current sensors” and configure “Phase” as DC. Accordingly, when “DC” is displayed under “Phase”, DC current and active power values are displayed on this page.

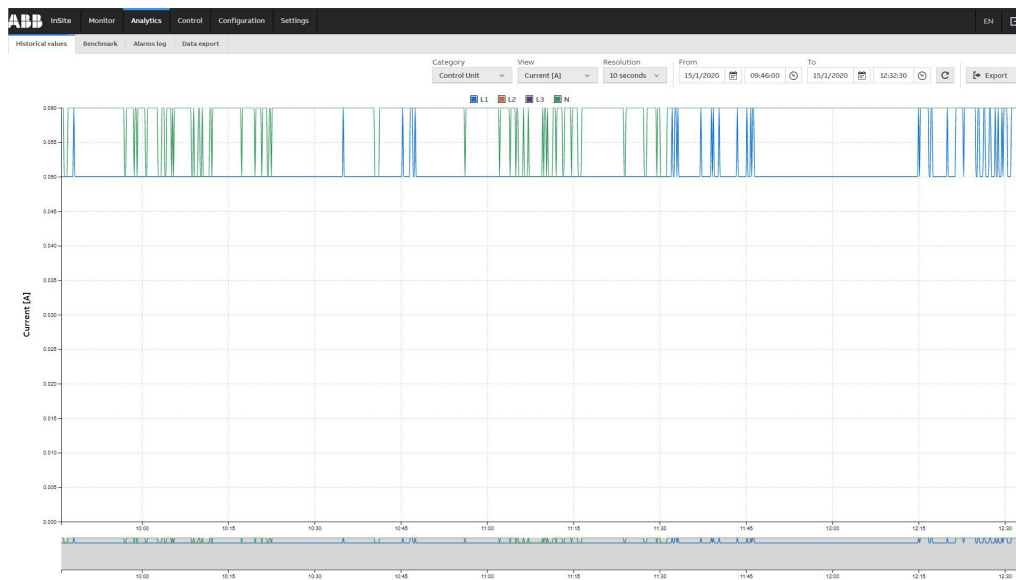

After selecting the parameter, the resolution and the reference time frame, the “Export” button allows the user to carry out direct data export as .CSV file.

13.2. Benchmark

Here it is possible to make comparisons between:

- Measurements of two different devices in the same time interval (By device)
- Measurements of one single device in two different time intervals (By period)

As in “Historical values” the resolution depends on the device selected and binds the maximum time interval that can be shown.

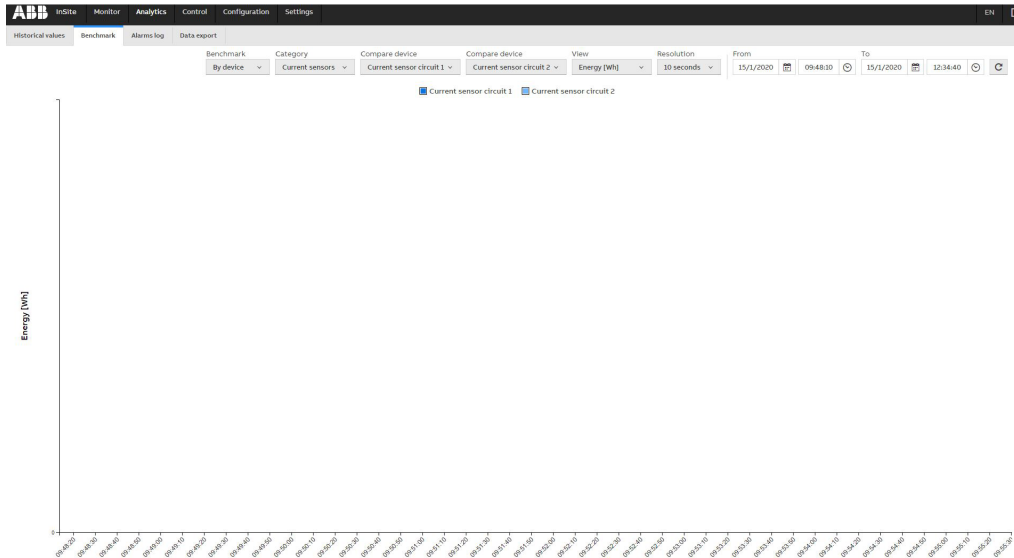

13.3. Alarms log

Here it is possible to show all the alarms that occurred. Here the table is automatically refreshed every second and displays the 100 latest events. Scrolling the table, more alarms are loaded.

Rows can be sorted and/or filtered by clicking at headers and selecting desired value from drop-down lists.



Alarms must previously be set in the “Alarms” configuration menu.

Event status is updated automatically every second to obtain new alarms occurrences.

It is possible to visualize and export occurrences according to user-defined start and end date/time.

The screenshot shows the ABB InSite Alarms log interface. At the top, there are navigation tabs: Historical values, Benchmark, Alarms log, and Data export. Below the tabs, there are configuration options: From (14/1/2020 12:36:09), To (15/1/2020 12:36:09), and an Export button. The main area is a table with the following columns: ID, Name, Device, Measure, Value, and Date and Time. The table contains 10 rows of data, with the most recent alarm at the top.

ID	Name	Device	Measure	Value	Date and Time
9	-	-	I	-[A]	11/12/2019, 13:02:51
8	-	-	I	-[A]	11/12/2019, 11:23:32
7	-	-	I	-[A]	10/12/2019, 17:47:28
6	-	-	I	-[A]	10/12/2019, 16:56:21
5	-	-	I	-[A]	10/12/2019, 16:44:11
4	-	-	I	-[A]	10/12/2019, 11:57:07
3	-	-	I	-[A]	10/12/2019, 11:56:00
2	-	-	I	-[A]	10/12/2019, 11:54:50
1	-	-	I	-[A]	10/12/2019, 11:53:31
0	-	-	I	-[A]	10/12/2019, 11:45:17

13.4.Data export

In order to carry out data export via email and/or FTP, contact data for email and FTP server need to be configured (see Settings → Email, FTP). Here you can export and/or download measurement and/or historical alarms of the configured devices and edit data export settings:

Device	Data	Frequency	Time	Email	FTP	Data stack	Alarms	Action
Control Unit	-	First day of every...	13:00	No	No	10 sec: No 15 min: No hour: No day: No week: No	No	
Current sensors	-	First day of every...	13:00	No	No	10 sec: No 15 min: No hour: No day: No week: No	No	
Meters	-	First day of every...	13:00	No	No	-	No	
I/O Modules	-	First day of every...	13:00	No	No	-	No	

Settings	
Data	Select type of data: “Total energy”, “Energy per phase”, “Instantaneous Values”, “Harmonics”.
Frequency	It indicates how often you would like to receive notifications.
Export time	Time, when the data shall be exported.
Export option	Two options can be selected: “One-time export” and “Perodic exporting”.
Export via email	If selected, mains and branches values will be exported as csv file by email. Please note that email configuration is needed.
Export via FTP	If selected, mains and branches values will be exported as csv file by FTP. Please note that FTP configuration is needed.
Data stack	Export data stack of last 1000 of 10 sec, 15 minutes, hour, day and week values.
Historical events	If selected, historical events wil be exported as .csv file via FTP according to the defined event log size.

14. WebUI – Control

14.1. Control

Here it is possible to change the status (open/close) of each single output port of the active modules and meters. A confirmation message is shown before completing the action.

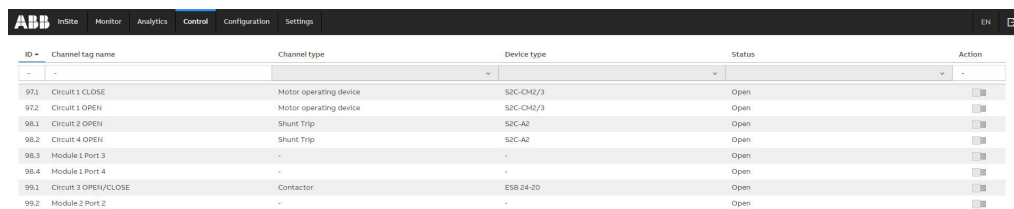

ID	Channel tag name	Channel type	Device type	Status	Action
-	-	-	-	-	-
97.1	Circuit1 CLOSE	Motor operating device	S2C-CH2/3	Open	<input type="checkbox"/>
97.2	Circuit1 OPEN	Motor operating device	S2C-CH2/3	Open	<input type="checkbox"/>
98.1	Circuit2 OPEN	Shunt Trip	S2C-A2	Open	<input type="checkbox"/>
98.2	Circuit4 OPEN	Shunt Trip	S2C-A2	Open	<input type="checkbox"/>
98.3	Module 1 Port 3	-	-	Open	<input type="checkbox"/>
98.4	Module 1 Port 4	-	-	Open	<input type="checkbox"/>
99.1	Circuit3 OPEN/CLOSE	Contactor	ESB 24-20	Open	<input type="checkbox"/>
99.2	Module 2 Port 2	-	-	Open	<input type="checkbox"/>



Only Administrator user is allowed to perform control of devices

To control meter output ports to Insite via Modbus, write registers with following description:

“Output X” (X – port number 1-4) – values 1/0 – on/off

15.Modbus TCP/RTU communication interface

15.1.Control unit mains and sensors readings

Introducing MODBUS protocol

The Modbus serial line protocol is a Master-Slaves protocol. This means that only one master and one or more slave nodes (max. 247) can be connected to the same serial bus. A Modbus communication is always initiated by the master and there is only one transaction at the same time.

For further information: www.modbus.org

If you intend to use Modbus, you should only use ASCII characters in the Web UI. Unicode characters will not be displayed in Modbus.

Modbus frame description (RTU mode)

Address	PDU Frame		Error Check
Address Field	Function Code	Data	CRC
1 byte	1 byte	0 - 252 bytes	2 bytes CRC _L , CRC _H
ADU		Application Data	
PDU		Protocol Data Unit	
Stopbit		1	
Address Field		contains the slave address	
Function Code:		indicates what kind of action to perform	
Data		contains request and response parameters	
CRC		contains the value generated by the cyclic redundancy check (standard CRC-16 defined by CCITT)	

The maximum size for a Modbus RTU frame is 256 bytes.



In RTU mode, message frames are separated by a silent interval of at least 3.5 character times.

The entire message frame must be transmitted as a continuous string of characters.

If a silent interval of more than 1.5 character times occurs between two characters, the message frame is declared as incomplete and should be discarded by the receiver.

Modbus Data Encoding

Modbus uses a big-endian allocation for addresses and data items. This means that, when a numerical quantity larger than a single byte is transmitted, the most significant byte is sent first.

Example: 1234h → first 12h then 34h

Communication to InSite

Physical Interface RS-485

To communicate with the InSite from an upper system, all devices (masters & slaves) must have the same data rate and data format. These settings are defined over the Web UI, as described in the dedicated chapter.

Parameter	Values	Default Values
Data rate	2400, 4800, 9600, 19200, 38400, 57600, 115200 Bit/s	19200 Bit/s
Data format	even parity, odd parity, without parity	even parity

This interface (port 5) can also be considered as an additional port for meters connection: to read them you have to select “Master” on WebUI configuration tab (Settings->Communication->Modbus).

Otherwise, if this 5th port interface is used to read data from the SCU-100 control unit and data from meters connected to the 4th port select “Slave”.

Control unit's MODBUS-ID

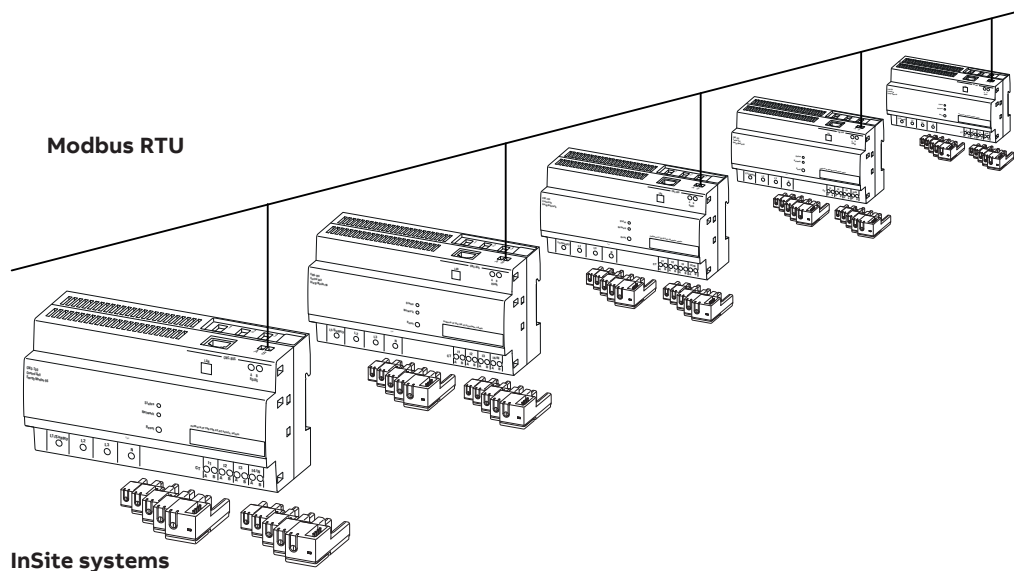

You can connect up to 247 control units to one Modbus RTU line. Each control unit must have a unique Modbus ID (address).

Function Code

- Read operation on registers with access code “R” or “RW” is defined by function 03h “Read Holding Registers”
- Write operation on registers with access code “W” or “RW” is defined by function 06h “Write Single Register”

Do not apply functions other than those specified.

Error Codes

Modbus protocol defines a common way of error reporting. Every request (read or write) sent in unicast mode is expected to return a value in packet of the same structure. In case of a message delivery error (not a CRC problem but a message execution problem), the generated response contains a function code with MSB (80h) set and a single byte representing the error code, called "exception code".

The following default exception codes are available:

Code	Name	Description
01h	Illegal function	Function is not supported
02h	Illegal data address	Register address is out of control unit's range, or trying to write into a read only register
03h	Illegal data value	Value is out of range
04h	Slave device failure	Unrecoverable error occurred while the control unit was attempting to perform the requested action, for example, time-out
06h	Slave device busy	Control unit is currently in User Interface Configuration Mode. Unable to execute the requested action .

Data and Control Registers

A register is always a two-byte (16-bit) value, which can be interpreted as either signed or unsigned values or which has a special format.

In case of data represented in more than one register the concatenated registers will contain information with MSB in the lowest address and LSB in the highest address within concatenated addresses.

Do not use registers other than those specified.



Format of one-word register for current values

unsigned	=	16-bit unsigned integer notation, resolution 0.01 A
signed	=	6-bit signed integer notation, resolution 0.01 A
0000h...7FEFh	=	0.00 ... 327.51 A
8000h...FFFFh	=	-327.66 ... -0.01 A

Values with special meanings

Special values (hex)	Special values (dec)	Meaning
7FF0	32'752	Data pending, acquisition in progress
7FF1 ... 7FFB	32'753 ... 32'763	Reserved
7FFC	32'764	The sensor is known but not accessible at the moment
7FFD	32'765	Data type TrueRMS / AC / DC is disabled
7FFE	32'766	Overload (beyond full range)
7FFF	32'767	Forbidden (no sensor with ID xx)



Format of double-word register for branch power and energy values

unsigned	=	32-bit unsigned integer notation,
signed	=	32-bit signed integer notation

Values with special meanings: Calculated branch power and energy values

Special values (hex)	Special values (dec)	Meaning
FFFF 7FF0	4'294'934'512	Data pending, acquisition in progress
FFFF 7FF1 ... FFFF 7FFB	4'294'934'513 ... 4'294'934'523	Reserved
FFFF 7FFC	4'294'934'524	The sensor is known but not accessible at the moment
FFFF 7FFD	4'294'934'525	Data type TrueRMS / AC / DC is disabled
FFFF 7FFE	4'294'934'526	Overload (beyond full range)
FFFF 7FFF	4'294'934'527	Forbidden (no sensor with ID xx)

bit mask = bit-wise operation

special = as specified in register description



Access

R (03) = Register can be read by function 03

W (06) = Register can be written by function 06

Trigger hold, reset min and max values

Write operation on this register triggers the hold measurement of all sensors, and/or resets the min and max values of all sensors.

Address (hex)	Address (dec)	Word (16-bit)	Description	Resolution and unit	Format 1	Access 2
3010	12'304	1	Trigger hold, reset min and max values		Bit Mask	W (06)

The commands have the following bit format: 0000 0000 000T 000R

- T 1 = Trigger hold measurement
- R 1 = Reset min and max values

The Command will be acknowledged by the response message on Modbus and by a short message.

Show sensor

“Write operation on this register starts or stops fast LED blinking of one specified sensor for diagnostic purpose.”

Address (hex)	Address (dec)	Word (16-bit)	Description	Resolution and unit	Format 1	Access 2
3011	12'305	1	Show Sensor		Special	W (06)

Start / stop command is in the following bit format position: 000S 0000 0CCC CCCC

- C Sensor ID
- S 1 = Starts fast LED blinking
- 0 = Stops fast LED blinking

Data written has to specify a known sensor ID.

Example: 0x1017 means “Start fast LED blinking of sensor with ID 23”

When sensor is addressed correctly, common response will follow

When the sensor ID is not used in the system, and exception response with Modbus exception code 03h “Illegal data value” will follow. (If fast LED blinking was already active, it will be stopped)

Return to normal display content is possible by sending the stop command.

Polarity of sensors (for DC currents)

These registers contain the configured nominal current value and the DC polarity information of each sensor with following bit format:

000P RRRR RRRR RRRR

- R Reserved for future use
- P DC polarity information
 - 0 = direct, DC current coming out of the cone is displayed positive
 - 1 = reverse, DC current coming out of the cone is displayed negative
 This setting has influence on all DC values of the specified sensor.

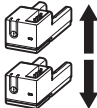
- 0000h DC polarity direct
 - 1000h DC polarity reverse
- 

This data has to be set user while system configuration. Factory default value is 0000h.

Serial number (SID), version and bus line of sensors

These registers contain system information about each sensor.

This data has to be set user while system configuration. Factory default value is 0000h.

Serial number (SID), version and bus line of sensors

These registers contain system information about each sensor.

Offset	Words	Data
0h	4	Unique Serial Number (SID)
4h	2	HW version
6h	3	SW version
9h	1	Measurement Range (0.1A steps)
Ah	1	Enabled Data Types (as in InSite Bus Protocol defined)
Bh	4	Reserved
Fh	1	ID of internal bus line sensor is connected to 0: no sensor, 1: line 1, 2: line 2

- Each sensor has a unique serial number needed for setup procedure on internal InSite bus.
- HW and SW version of sensor are readable for diagnosis purpose.
- “ID of internal bus line” identifies the Control Unit’s internal bus line the sensor is connected to.

This data is not hold always in registers but will be prepared on read request.

15.2.Meters

Insite pro M allows to connect up to 16 meters with RS-485 interface. Supported are ABB M4M, M2M, M1M, DMTME, IM300 and EQ meters with Modbus RTU communication protocol. Each meter can be assigned to Modbus ID from 1 to 16.



Proper meter support may depend on its firmware version. Please update the meter with latest firmware version before connecting it to control unit.

Data from meters are available on the control unit WebUI and using Modbus TCP or Modbus RTU protocol. When accessing through Modbus protocol, registers of each connected meter are mapped to control unit static register map. The map is attached in the Excel file in the tab cu insite:

External Modbus address	Slave Modbus ID	External Modbus data type	Category	Quantity	Registers
37062	1	Unsigned integer	Energies Ph/Tariff	Active import L1..L3, tar 1..8	96
37158	1	Unsigned integer	Energies Ph/Tariff	Active export L1..L3, tar 1..8	96
37254	1	Unsigned integer	Energies Ph/Tariff	Reactive import L1..L3, tar 1..8	96
37350	1	Unsigned integer	Energies Ph/Tariff	Reactive export L1..L3, tar 1..8	96
37446	1	Unsigned integer	Energies Ph/Tariff	Apparent import L1..L3, tar 1..8	96
37542	1	Unsigned integer	Energies Ph/Tariff	Apparent export L1..L3, tar 1..8	96
37638	1	Unsigned integer	Energies phases	Active import L1	4
37642	1	Unsigned integer	Energies phases	Active import L2	4
37650	1	Unsigned integer	Energies phases	Active export L1	4

Control unit register map provides information about address for each quantity, number of registers on which it is presented and data type. The details for each register depend from meter type which is connected to specific slave Modbus ID and are available in the Excel file in the tab meters.

E.g. EQ meter is connected to Modbus ID 1. The Active import L1 variable is available on the control unit register address 37638. It can be read from the meters tab in Excel file that the unit for this register is kWh, register is not writable, quantity is refreshed every 30 seconds for Modbus and WebUI and stored every 900 seconds on the internal flash memory. The multiplier for this register is 0.01. To retrieve this quantity the EQ meter Modbus register 5460 is queried.

Category	Quantity	External Modbus data type	External Modbus registers	Unit	Writable	EQ meter registers	M4M address
Energies phases	Active import L1	Unsigned integer	0	kWh		4	5460
Energies phases	Active import L2	Unsigned integer	0	kWh		4	5464
Energies phases	Active import L3	Unsigned integer	0	kWh		4	5468

M4M multiplier	M2M address	M2M multiplier	EQ meter Modbus	EQ meter webserver	EQ meter storage	EQ meter address	EQ meter multiplier
0,01	1074	0,1	30	30	900	5460	0,01
0,01	1076	0,1	30	30	900	5464	0,01
0,01	1078	0,1	30	30	900	5468	0,01

If the register address for quantity is 0, then it means that meter is not queried for this value and it is calculated by control unit, using other available data.

If frequency for data refresh for Modbus, webserver or storage is 0, then data are requested/stored on demand (when changed).

More details about each quantity is available in user manual for specific meter and can be accessed using meter address from meters tab in the Excel file.

15.3.I/O modules

Insite pro M allows to connect up to 24 I/O modules. I/O modules can be assigned to Modbus ID from 97 to 120 and can be read/control using web UI and Modbus TCP/RTU protocols. Registers of each connected I/O module are statically mapped in the control unit register map available in the attached Excel file in the tab cu insite.

External Modbus address	Slave Modbus ID	External Modbus data type	Category	Quantity	Registers
58502	97	Unsigned integer	IO module	I/O configuration	1
58503	97	Unsigned integer	IO module	Pulse Counter Port 0	2
58505	97	Unsigned integer	IO module	Pulse Counter Port 1	2
58507	97	Unsigned integer	IO module	Pulse Counter Port 2	2
58509	97	Unsigned integer	IO module	Pulse Counter Port 3	2
58511	97	Unsigned integer	IO module	Status Contacts Port 0	1
58512	97	Unsigned integer	IO module	Status Contacts Port 1	1
58513	97	Unsigned integer	IO module	Status Contacts Port 2	1
58514	97	Unsigned integer	IO module	Status Contacts Port 3	1

Control unit register map, provides information about address for each quantity, number of registers on which it is presented and data type. The details for each registers are available in the Excel file in the tab I/O modules.

E.g. Output module is connected to Modbus ID 97. Status of contacts can be read from control unit register address 58511, size of the quantity is 1 register and data type is unsigned integer. Additionally it can be read from Excel file tab I/O modules that this register is writable and is and data available by Modbus or WebUI is refreshed every 1 second.

Category	Quantity	External Modbus data type	IO module address	External Modbus registers
IO module	I/O configuration	Unsigned integer	40	1
IO module	Pulse Counter Port 0	Unsigned integer	50	2
IO module	Pulse Counter Port 1	Unsigned integer	52	2
IO module	Pulse Counter Port 2	Unsigned integer	54	2
IO module	Pulse Counter Port 3	Unsigned integer	56	2
IO module	Status Contacts Port 0	Unsigned integer	0	1
IO module	Status Contacts Port 1	Unsigned integer	1	1
IO module	Status Contacts Port 2	Unsigned integer	2	1
IO module	Status Contacts Port 3	Unsigned integer	3	1

Writable	IO module Modbus	IO module webserver	IO module storage	External Modbus
x	0	0	0	1
	1	1	1	1
	1	1	1	1
	1	1	1	1
	1	1	1	1
x	1	1	1	1
x	1	1	1	1
x	1	1	1	1
x	1	1	1	1

15.4. External Modbus alarm registers for IOM

There are five alarm registers assigned to single IO module in the external Modbus registers map.

Alarm status Port 0	1
Alarm status Port 1	1
Alarm status Port 2	1
Alarm status Port 3	1
Alarm status module	1

Possible alarm values for Alarm status Port x registers are:

```
NO_EVENT = 0
CROSS_UP = 1
CROSS_DOWN = 2
STATUS_CHANGE = 3
```

Possible alarm values for Alarm status module register are:

```
NO_EVENT = 0
COMMUNICATION_FAIL = 4
COMMUNICATION_RESTORE = 5
```



Alarms are cleared when master/slave configuration for Modbus RTU is changed. Once value is written to the register it is maintained until next alarm occurs; this next alarm overwrites register value.

16. Simple Network Management Protocol – SNMP

Reading of values

The protocol is applicable for the following items:

- Mains parameters
- Calculated values
- Measured branch current values

If you need to record the values of a subsequent measurement, you have to use the SNMP protocol and the external storage system. Historical data in the device is stored with a resolution of 10s.

Special values for error codes

In a fail situation you get error codes. Values with special meanings for branch current values (one word, 16bit) are summarized below.

Special values (hex)	Special values (dec)	Meaning
7FF0	32'752	Data pending, acquisition in progress
7FF1 ... 7FFB	32'753 ... 32'763	Reserved
7FFC	32'764	The sensor is known but not accessible at the moment
7FFD	32'765	Data type TrueRMS / AC / DC is disabled
7FFE	32'766	Overload (beyond full range)
7FFE	32'767	Forbidden (no sensor with ID xx)

Values with special meanings for calculated branch power and energy values (double word, 32bit) are reported below:

Special values (hex)	Special values (dec)	Meaning
7FF0	32'752	Data pending, acquisition in progress
7FF1 ... 7FFB	32'753 ... 32'763	Reserved
7FFC	32'764	The sensor is known but not accessible at the moment
7FFD	32'765	Data type TrueRMS / AC / DC is disabled
7FFE	32'766	Overload (beyond full range)
7FFE	32'767	Forbidden (no sensor with ID xx)

MIB

To retrieve data from the device using the SNMP object identifier (OID), the MIB file downloaded from the webui should be copied to the correct location on the client station. The SNMPv2-MIB is distributed with the net-snmp package.

The NET-SNMP package can be downloaded from the link:

<https://sourceforge.net/projects/net-snmp/files/net-snmp/5.8/>

In the downloaded zip package, MIB files are available in directory: net-snmp-5.8.zip\net-snmp-5.8\mibs\

The information about system is available in the SNMPv2-MIB and is presented in Table 1.

```
snmpwalk -v2c -ccommunity ip_address:port SNMPv2-MIB::system
SNMPv2-MIB::sysDescr.0 = STRING: InSite pro M
SNMPv2-MIB::sysObjectID.0 = OID: SNMPv2-SMI::enterprises.8072.3.2.10
SNMPv2-MIB::sysUpTime.0 = Timeticks: (6242832) 17:20:28.32
SNMPv2-MIB::sysName.0 = STRING: InSite
SNMPv2-MIB::sysLocation.0 = TRING: Location of the InSite pro M Control Unit
SNMPv2-MIB::sysServices.0 = INTEGER: 72
```

To print all SNMP variables available in SCU-100:

```
# snmpwalk -v3 -e engine_id -u security_name -a MD5 -A password -x DES -X password -l
authPriv 192.168.1.200:161 INSITE::insite
INSITE::tRMSsens1 = INTEGER: 0
INSITE::tRMSsens2 = INTEGER: 0
```

16.1.SNMP objects

SNMP Object Identifier	SMI Data Type	SMI Data Type Example Value
SNMPv2-MIB::sysDescr.0	STRING	ABBCircuitMeasurementSystemInsite
SNMPv2-MIB::sysUpTime.0	Timeticks	(117750) 0:19:37.50
SNMPv2-MIB::sysName.0	STRING	CMS700
SNMPv2-MIB::sysLocation.0	STRING	Location of the Insite
SNMPv2-MIB::sysServices.0	INTEGER	72

All objects are read-only.

To return all TRMSsens values in a single snmpget request, please use the “TRMSsensAll” variable name.

Examples

Some examples of usage on the Linux system using snmpget program from NET-SNMP package are presented below. The ‘#’ is the Linux command prompt.

SNMPv1

```
# snmpget -v1 -c community_name 192.168.1.200:161 SNMPv2-MIB::sysUpTime.0
SNMPv2-MIB::sysUpTime.0 = Timeticks: (38471) 0:06:24.71
```

SNMPv2c

```
# snmpwalk -v2c -c community_name 192.168.1.200:161 SNMPv2-MIB::system
SNMPv2-MIB::sysDescr.0 = STRING: InSite pro M
SNMPv2-MIB::sysObjectID.0 = OID: SNMPv2-SMI::enterprises.8072.3.2.10
SNMPv2-MIB::sysUpTime.0 = Timeticks: (6353707) 17:38:57.07
SNMPv2-MIB::sysName.0 = STRING: InSite
SNMPv2-MIB::sysLocation.0 = STRING: Location of the InSite pro M Control Unit
SNMPv2-MIB::sysServices.0 = INTEGER: 72
```

```
# snmpget -v2c -c community_name 192.168.1.200:161 INSITE::tRMSsens1
INSITE::tRMSsens1 = INTEGER: 32767
```

```
# snmpwalk -v2c -c community_name 192.168.1.200:161 INSITE::tRMSsens
INSITE::tRMSsens1 = INTEGER: 32767
INSITE::tRMSsens2 = INTEGER: 32767
INSITE::tRMSsens3 = INTEGER: 32767
INSITE::tRMSsens4 = INTEGER: 32767
INSITE::tRMSsens5 = INTEGER: 32767
INSITE::tRMSsens6 = INTEGER: 32767
INSITE::tRMSsens7 = INTEGER: 32767
INSITE::tRMSsens8 = INTEGER: 32767
INSITE::tRMSsens9 = INTEGER: 32767
INSITE::tRMSsens10 = INTEGER: 32767
INSITE::tRMSsens11 = INTEGER: 32767
INSITE::tRMSsens12 = INTEGER: 32767
INSITE::tRMSsens13 = INTEGER: 32767
```

SNMPv3

```
# snmpget -v3 -e engine_id -u security_name -a MD5 -A password -x DES -X password -l  
authPriv 192.168.1.200:161 INSITE::tRMSsens1  
INSITE::tRMSsens1 = INTEGER: 32767
```

```
# snmpgetnext -v3 -e engine_id -u security_name -a MD5 -A password -x DES -X password -l  
authPriv 192.168.1.200:161 INSITE::tRMSsens1  
INSITE::tRMSsens2 = INTEGER: 32767
```

```
# snmpwalk -v3 -e engine_id -u security_name -a MD5 -A password -x DES -X password -l  
authPriv 192.168.1.200:161 INSITE::tRMSsens  
INSITE::tRMSsens1 = INTEGER: 32767  
INSITE::tRMSsens2 = INTEGER: 32767  
INSITE::tRMSsens3 = INTEGER: 32767  
INSITE::tRMSsens4 = INTEGER: 32767  
INSITE::tRMSsens5 = INTEGER: 32767  
INSITE::tRMSsens6 = INTEGER: 32767  
INSITE::tRMSsens7 = INTEGER: 32767  
INSITE::tRMSsens8 = INTEGER: 32767  
INSITE::tRMSsens9 = INTEGER: 32767  
INSITE::tRMSsens10 = INTEGER: 32767
```

Modbus Standard TCP Port: 502**Standard SNMP UDP Port: 161****• Modbus map (according to firmware version 1.1.0)**

Addr. (hex)	Addr. (dec)	Word (16-bit)	Description	Resolution (1-bit value)	Unit	Format	Access	SNMP Variable Name
Ongoing measurement values:								
These registers contain the actual measured data.								
0000	0	1	TRMS value of Sensor 1	0.01	A	unsigned	R (03)	tRMSsens1
0001	1	1	TRMS value of Sensor 2	0.01	A	unsigned	R (03)	tRMSsens2
...	...	1	...	0.01	A	unsigned	R (03)	...
005F	95	1	TRMS value of Sensor 96	0.01	A	unsigned	R (03)	tRMSsens96
0100	256	1	AC value of Sensor 1	0.01	A	unsigned	R (03)	aCsens1
0101	257	1	AC value of Sensor 2	0.01	A	unsigned	R (03)	aCsens2
...	...	1	...	0.01	A	unsigned	R (03)	...
005F	351	1	AC value of Sensor 96	0.01	A	unsigned	R (03)	aCsens96
0200	512	1	DC value of Sensor 1	0.01	A	signed	R (03)	dCsens1
0201	513	1	DC value of Sensor 2	0.01	A	signed	R (03)	dCsens2
...	...	1	...	0.01	A	signed	R (03)	...
025F	607	1	DC value of Sensor 96	0.01	A	signed	R (03)	dCsens96
Minimum measured values:								
These registers contain the minimum measured values since last system start / reset or since last "reset min/max values" request.								
0400	1'024	1	TRMS min value of Sensor 1	0.01	A	unsigned	R (03)	mINTRMSsens1
0401	1'025	1	TRMS min value of Sensor 2	0.01	A	unsigned	R (03)	mINTRMSsens2
...	...	1	...	0.01	A	unsigned	R (03)	...
045F	1'119	1	TRMS min value of Sensor 96	0.01	A	unsigned	R (03)	mINTRMSsens96
0500	1'280	1	AC min value of Sensor 1	0.01	A	unsigned	R (03)	mINACsens1
0501	1'281	1	AC min value of Sensor 2	0.01	A	unsigned	R (03)	mINACsens2
...	...	1	...	0.01	A	unsigned	R (03)	...
055F	1'375	1	AC min value of Sensor 96	0.01	A	unsigned	R (03)	mINACsens96
0600	1'536	1	DC min value of Sensor 1	0.01	A	signed	R (03)	mINACsens97
0601	1'537	1	DC min value of Sensor 2	0.01	A	signed	R (03)	mINACsens98
...	...	1	...	0.01	A	signed	R (03)	...
065F	1'631	1	DC min value of Sensor 96	0.01	A	signed	R (03)	mINACsens192
Maximum measured values:								
These registers contain the maximum measured values since last system start / reset or since last "reset min/max values" request.								
0800	2'048	1	TRMS max value of Sensor 1	0.01	A	unsigned	R (03)	mAXTRMSsens1
0801	2'049	1	TRMS max value of Sensor 2	0.01	A	unsigned	R (03)	mAXTRMSsens2
...	...	1	...	0.01	A	unsigned	R (03)	...
085F	2'143	1	TRMS max value of Sensor 96	0.01	A	unsigned	R (03)	mAXTRMSsens96
0900	2'304	1	AC max value of Sensor 1	0.01	A	unsigned	R (03)	mAXACsens1
0901	2'305	1	AC max value of Sensor 2	0.01	A	unsigned	R (03)	mAXACsens2
...	...	1	...	0.01	A	unsigned	R (03)	...
095F	2'399	1	AC max value of Sensor 96	0.01	A	unsigned	R (03)	mAXACsens96
0A00	2'560	1	DC max value of Sensor 1	0.01	A	signed	R (03)	mAXDCsens1
0A01	2'561	1	DC max value of Sensor 2	0.01	A	signed	R (03)	mAXDCsens2
...	...	1	...	0.01	A	signed	R (03)	...
0A5F	2'655	1	DC max value of Sensor 96	0.01	A	signed	R (03)	mAXDCsens96

Addr. (hex)	Addr. (dec)	Word (16-bit)	Description	Resolution (1-bit value)	Unit	Format	Access	SNMP Variable Name
Measured hold values:								
These registers contain the hold values captured at a given time during the execution of a "trigger hold measurement" request.								
0C00	3'072	1	TRMS hold value of Sensor 1	0.01	A	unsigned	R (03)	hOLDTRMSsens1
0C01	3'073	1	TRMS hold value of Sensor 2	0.01	A	unsigned	R (03)	hOLDTRMSsens2
...	...	1	...	0.01	A	unsigned	R (03)	...
0C5F	3'167	1	TRMS hold value of Sensor 96	0.01	A	unsigned	R (03)	hOLDTRMSsens96
0D00	3'328	1	AC hold value of Sensor 1	0.01	A	unsigned	R (03)	hOLDACsens1
0D01	3'329	1	AC hold value of Sensor 2	0.01	A	unsigned	R (03)	hOLDACsens2
...	...	1	...	0.01	A	unsigned	R (03)	...
0D5F	3'423	1	AC hold value of Sensor 96	0.01	A	unsigned	R (03)	hOLDACsens96
0E00	3'584	1	DC hold value of Sensor 1	0.01	A	signed	R (03)	hOLDDCsens1
0E01	3'585	1	DC hold value of Sensor 2	0.01	A	signed	R (03)	hOLDDCsens2
...	...	1	...	0.01	A	signed	R (03)	...
0E5F	3'679	1	DC hold value of Sensor 96	0.01	A	signed	R (03)	hOLDDCsens96
Serial number (SID), version and bus line								
1000	4'096	16	SID, version, bus line of sensor 1			special	R (03)	siDSens1
1010	4'112	16	SID, version, bus line of sensor 2			special	R (03)	siDSens2
...	...	16	...			special	R (03)	...
15F0	5'616	16	SID, version, bus line of sensor 96			special	R (03)	siDSens96
Polarity of sensors (for DC currents)								
2000	8'192	1	Polarity of sensor 1			special	RW (03,06,10)	pOLsens1
2001	8'193	1	Polarity of sensor 2			special	RW (03,06,10)	pOLsens2
...	...	1	...			special	RW (03,06,10)	...
205F	8'287	1	Polarity of sensor 96			special	RW (03,06,10)	pOLsens96
Calculated values of sensors								
2200	8'704	2	Active Power value of Sensor 1	1	W	unsigned	R (03)	psens1
2202	8'706	2	Active Power value of Sensor 2	1	W	unsigned	R (03)	psens2
...	...	2	...	1	W	unsigned	R (03)	...
22BE	8'894	2	P value of Sensor 96	1	W	unsigned	R (03)	psens96
2300	8'960	2	Active Energy value of Sensor 1	0.1	Wh	unsigned	R (03)	whsens1
2302	8'962	2	Active Energy value of Sensor 2	0.1	Wh	unsigned	R (03)	whsens2
...	...	2	...	0.1	Wh	unsigned	R (03)	...
23BE	9'150	2	Active Energy value of Sensor 96	0.1	Wh	unsigned	R (03)	whsens96
Calculated values of groups								
2400	9'216	2	Active Power value of Group 1	1	W	unsigned	R (03)	pGroup1
2402	9'218	2	Active Power value of Group 2	1	W	unsigned	R (03)	pGroup2
...
24BE	9'406	2	Active Power value of Group 96	1	W	unsigned	R (03)	pGroup96
2500	9'472	2	Active Energy value of Group 1	100	Wh	unsigned	R (03)	whGroup1
2502	9'472	2	Active Energy value of Group 2	100	Wh	unsigned	R (03)	whGroup2
...	...	2	...	100	Wh	unsigned	R (03)	...
25BE	9'662	2	Active Energy value of Group 96	100	Wh	unsigned	R (03)	whGroup96
Control registers								
3001	12'289	1	Physical assignment of sensor time-out, UI mode	0.1	s	unsigned	RW (03,06)	uiTIMEOUTsens
3002	12'290	1	Physical assignment of sensor time-out, UI mode	0.1	s	unsigned	RW (03,06)	busTIMEOUTsens

Addr. (hex)	Addr. (dec)	Word (16-bit)	Description	Resolution (1-bit value)	Unit	Format	Access	SNMP Variable Name
Branches								
3200	12'800	64	Branch name of Sensor 1	64	letter	string	RW (03,10)	branchNamesens1
3240	12'864	64	Branch name of Sensor 2	64	letter	string	RW (03,10)	branchNamesens2
...	...	64	...	64	letter	string	RW (03,10)	...
49C0	18'880	64	Branch name of Sensor 96	64	letter	string	RW (03,10)	branchNamesens96
5200	20'992	64	Name of Group 1*	64	letter	string	RW (03,10)	groupName1
5240	21'056	64	Name of Group 2	64	letter	string	RW (03,10)	groupName2
...	...	64	...	64	letter	string	RW (03,10)	...
69C0	27'072	64	Name of Group 96	64	letter	string	RW (03,10)	groupName96
7200	29'184	1	Phase assigned to Sensor 1	1		short	RW (03,06)	phasesens1
7201	29'185	1	Phase assigned to Sensor 2	1		short	RW (03,06)	phasesens2
...	...	1	...	1		short	RW (03,06)	...
725F	29'279	1	Phase assigned to Sensor 96	1		short	RW (03,06)	phasesens96
7280	29'312	1	Group number of Sensor 1**	1		short	RW (03,06)	groupsens1
7281	29'313	1	Group number of Sensor 2	1		short	RW (03,06)	groupsens2
...	...	1	...	1		short	RW (03,06)	...
72DF	29'407	1	Group number of Sensor 96	1		short	RW (03,06)	groupsens96
7300	29'440	1	Power Factor of Sensor 1	0.01		unsigned	RW (03,06)	powerFactorsens1
7301	29'441	1	Power Factor of Sensor 2	0.01		unsigned	RW (03,06)	powerFactorsens2
...	...	1	...	0.01		unsigned	RW (03,06)	...
735F	29'535	1	Power Factor of Sensor 96	0.01		unsigned	RW (03,06)	powerFactorsens96
Alarm/Event Status – only Status								
8000	32'768	1	Number of current alarms			unsigned	R (03)	
8001	32'769	1	Alarm Status Branch 1			unsigned	R (03)	
8002	32'770	1	Alarm Status Branch 2			unsigned	R (03)	
...	...	1	...			unsigned	R (03)	
8060	32'864	1	Alarm Status Branch 96			unsigned	R (03)	
8061	32'865	1	Alarm Status Line L1			unsigned	R (03)	
8062	32'866	1	Alarm Status Line L2			unsigned	R (03)	
8063	32'867	1	Alarm Status Line L3			unsigned	R (03)	
8064	32'868	1	Alarm Status Line L4/N			unsigned	R (03)	
Alarm/Event Status – Status and Threshold								
8100	33'024	1	Number of current alarms			unsigned	R (03)	
8101	33'025	1	Alarm Status Branch 1			unsigned	R (03)	
8102	33'026	2	Alarm Threshold Branch 1			signed	R (03)	
8104	33'028	1	Alarm Status Branch 2			unsigned	R (03)	
8105	33'029	2	Alarm Threshold Branch 2			signed	R (03)	
...	...						R (03)	
821E	33'310	1	AlarmStatusBranch96			unsigned	R (03)	
821F	33'311	2	AlarmThresholdBranch96			signed	R (03)	
...	...							
8221	33'313	1	AlarmStatusLine L1			unsigned	R (03)	
8222	33'314	2	AlarmThresholdLine L1			signed	R (03)	
8224	33'316	1	AlarmStatusLine L2			unsigned	R (03)	
8225	33'317	2	AlarmThresholdLine L2			signed	R (03)	
8227	33'319	1	AlarmStatusLine L3			unsigned	R (03)	
8228	33'320	2	AlarmThresholdLine L3			signed	R (03)	
822A	33'322	1	AlarmStatusLine L4/N			unsigned	R (03)	
822B	33'323	2	AlarmThresholdLine L4/N			signed	R (03)	

Addr. (hex)	Addr. (dec)	Word (16-bit)	Description	Resolution (1-bit value)	Unit	Format	Access	SNMP Variable Name
Mains measurement registers								
9002	36'866	2	PHASE VOLTAGE L1-N	0.01	V	unsigned	R (03)	uL1
9004	36'868	2	PHASE VOLTAGE L2-N	0.01	V	unsigned	R (03)	uL2
9006	36'870	2	PHASE VOLTAGE L3-N	0.01	V	unsigned	R (03)	uL3
9010	36'880	2	LINE CURRENT L1	0.01	A	unsigned	R (03)	iL1
9012	36'882	2	LINE CURRENT L2	0.01	A	unsigned	R (03)	iL2
9014	36'884	2	LINE CURRENT L3	0.01	A	unsigned	R (03)	iL3
9016	36886	2	LINE CURRENT L4/N	0,01	A	unsigned	R (03)	iL4N
9018	36'888	2	POWER FACTOR L1	0,01		signed	R (03)	pfl1
901A	36'890	2	POWER FACTOR L2	0,01		signed	R (03)	pfl2
901C	36'892	2	POWER FACTOR L3	0,01		signed	R (03)	pfl3
3-PHASE SUM APPARENT POWER								
9026	36'902	2	APPARENT POWER L1	1	VA	unsigned	R (03)	s3
9028	36'904	2	APPARENT POWER L2	1	VA	unsigned	R (03)	sL1
902A	36'906	2	APPARENT POWER L2	1	VA	unsigned	R (03)	sL2
902C	36'908	2	APPARENT POWER L3	1	VA	unsigned	R (03)	sL3
3-PHASE SUM ACTIVE POWER								
902E	36'910	2	ACTIVE POWER L1	1	W	signed	R (03)	p3
9030	36'912	2	ACTIVE POWER L1	1	W	signed	R (03)	pL1
9032	36'914	2	ACTIVE POWER L2	1	W	signed	R (03)	pL2
9034	36'916	2	ACTIVE POWER L3	1	W	signed	R (03)	pL3
3-PHASE SUM REACTIVE POWER								
9036	36'918	2	REACTIVE POWER L1	1	Var	signed	R(03)	q3
9038	36'920	2	REACTIVE POWER L1	1	Var	signed	R (03)	qL1
903A	36'922	2	REACTIVE POWER L2	1	Var	signed	R (03)	qL2
903C	36'924	2	REACTIVE POWER L3	1	Var	signed	R (03)	qL3
3-PHASE SYS ACTIVE ENERGY								
903E	36'926	2	3-PHASE SYS REACTIVE ENERGY	0.01	Wh	unsigned	R (03)	wh3
3-PHASE SYS REACTIVE ENERGY								
9040	36'928	2	ACTIVE ENERGY L1	0.01	Varh	unsigned	R (03)	qh3
9074	36'980	2	ACTIVE ENERGY L1	0.01	Wh	unsigned	R (03)	whL1
9076	36'982	2	ACTIVE ENERGY L2	0.01	Wh	unsigned	R (03)	whL2
9078	36'984	2	ACTIVE ENERGY L3	0.01	Wh	unsigned	R (03)	whL3
907A	36'986	2	REACTIVE ENERGY L1	0.01	Varh	unsigned	R (03)	qhL1
907C	36'988	2	REACTIVE ENERGY L2	0.01	Varh	unsigned	R (03)	qhL2
907E	36'990	2	REACTIVE ENERGY L3	0.01	Varh	unsigned	R (03)	qhL3
3-PHASE SYS APPARENT ENERGY								
90A6	37'030	2	APPARENT ENERGY L1	0.01	VAh	unsigned	R (03)	sh3
90A8	37'032	2	APPARENT ENERGY L1	0,01	VAh	unsigned	R (03)	shL1
90AA	37'034	2	APPARENT ENERGY L2	0,01	VAh	unsigned	R (03)	shL2
90AC	37'036	2	APPARENT ENERGY L3	0,01	VAh	unsigned	R (03)	shL3
908E	37006	2	LINE CURRENT THD L4/N	0,01	%	unsigned	R (03)	thdL4N
9090	37008	1	CT ratio L1L2L3	0,1	0.1-6000	unsigned	RW (03,06)	cTratioL1L2L3
9091	37009	1	CT ratio N	0,1	0.1-6000	unsigned	RW (03,06)	cTratioN
9082	36'994	2	VOLTAGE THD L1	0.01	%	unsigned	R (03)	thdUL1
9084	36'996	2	VOLTAGE THD L2	0.01	%	unsigned	R (03)	thdUL2
9086	36'998	2	VOLTAGE THD L3	0.01	%	unsigned	R (03)	thdUL3

Addr. (hex)	Addr. (dec)	Word (16-bit)	Description	Resolution (1-bit value)	Unit	Format	Access	SNMP Variable Name
Mains measurement registers								
90AE	37'038	2	ACTIVE ENERGY L1 100Wh	100	Wh	unsigned	R (03)	whL1-100
90B0	37'040	2	ACTIVE ENERGY L2 100Wh	100	Wh	unsigned	R (03)	whL2-100
90B2	37'042	2	ACTIVE ENERGY L3 100Wh	100	Wh	unsigned	R (03)	whL3-100
90B4	37'044	2	3-PHASE SUM ACTIVE ENERGY 100Wh	100	Wh	unsigned	R (03)	wh3-100
90B6	37'046	2	REACTIVE ENERGY L1 100varh	100	varh	unsigned	R (03)	qhL1-100
90B8	37'048	2	REACTIVE ENERGY L2 100varh	100	varh	unsigned	R (03)	qhL2-100
90BA	37'050	2	REACTIVE ENERGY L3 100varh	100	varh	unsigned	R (03)	qhL3-100
90BC	37'052	2	3-PHASE SUM REACTIVE ENERGY 100varh	100	varh	unsigned	R (03)	qh3-100
90BE	37'054	2	APPARENT ENERGY L1 100VAh	100	VAh	unsigned	R (03)	shL1-100
90C0	37'056	2	APPARENT ENERGY L2 100VAh	100	VAh	unsigned	R (03)	shL2-100
90C2	37'058	2	APPARENT ENERGY L3 100VAh	100	VAh	unsigned	R (03)	shL3-100
90C4	37'060	2	3-PHASE SUM APPARENT ENERGY 100VAh	100	VAh	unsigned	R (03)	sh3-100
9088	37'000	2	CURRENT THD L1	0.01	%	unsigned	R (03)	thdIL1
908A	37'002	2	CURRENT THD L2	0.01	%	unsigned	R (03)	thdIL2
908C	37'004	2	CURRENT THD L3	0.01	%	unsigned	R (03)	thdIL3

*) 96 group names with max. 64 characters can be defined in the Web-UI. The register contains the group name included in the group name list.
The register indicates the number of the group within the group name list.

***) The register indicates the number of the group in the group name list.

These registers contain the general overview of the system, from numbers of channels and connected devices to SCU100 configuration.

Addr. (hex)	Addr. (dec)	Word (16-bit)	Slave Modbus ID	Category	Description	Unit	Format	Access
FBDE	6447	8	1	0	System view	Nr of connected meters	-	Unsigned R
FBDF	64479	1	0	0	System view	Nr of sensors	-	Unsigned R
FBE0	64480	1	0	0	System view	Nr of IO modules	-	Unsigned R
FBE1	64481	1	0	0	System view	Nr of Input channels	-	Unsigned R
FBE2	64482	1	0	0	System view	Nr of pulse channels	-	Unsigned R
FBE3	64483	1	0	0	System view	Nr of Output channels	-	Unsigned R
FBE4	64484	6	0	0	System view	Control unit serial number	text	String R
FBEA	64490	2	0	0	System view	FW version	text	String R
FBEC	64492	1	0	0	System view	Modbus mapping version	-	Unsigned R
FBED	64493	1	0	0	System view	Slave ID	-	Unsigned R
FBEE	64494	2	0	0	System view	IP address	-	Unsigned R
FBF0	64496	2	0	0	System view	Sub-net mask	-	Unsigned R
FBF2	64498	3	0	0	System view	MAC address	-	Unsigned R
FBF5	64501	3	0	0	System view	Alarm status	-	Unsigned (yet unsp.) R
FBF7	64503	3	0	0	System view	Control unit tag name	text	String R

Active, reactive and apparent energy per phase, both import and export, of EQ meter/M4M/M2M with Slave ID = 1

Addr. (hex)	Addr. (dec)	Word (16-bit)	Slave Modbus ID	Category	Description	Unit	Format	Access	EQ Meter Resolution	M4M Res.	M2M Res.
90C6	37062	96	1	Energies Ph/Tariff	Active import L1..L3, tar 1..8	kWh	Unsigned	R	1	1	0.1
9126	3715	8	96	Energies Ph/Tariff	Active export L1..L3, tar 1..8	kWh	Unsigned	R	1	1	0.1
9186	37254	96	1	Energies Ph/Tariff	Reactive import L1..L3, tar 1..8	kvarh	Unsigned	R	1	1	0.1
91E6	37350	96	1	Energies Ph/Tariff	Reactive export L1..L3, tar 1..8	kvarh	Unsigned	R	1	1	0.1
9246	37446	96	1	Energies Ph/Tariff	Apparent import L1..L3, tar 1..8	kVAh	Unsigned	R	1	1	0.1
92A6	37542	96	1	Energies Ph/Tariff	Apparent export L1..L3, tar 1..8	kVAh	Unsigned	R	1	1	0.1
9306	37638	4	1	Energies phases	Active import L1	kWh	Unsigned	R	0.01	0.01	0.1
930A	37642	4	1	Energies phases	Active import L2	kWh	Unsigned	R	0.01	0.01	0.1
930E	37646	4	1	Energies phases	Active import L3	kWh	Unsigned	R	0.01	0.01	0.1
9312	37650	4	1	Energies phases	Active export L1	kWh	Unsigned	R	0.01	0.01	0.1
9316	37654	4	1	Energies phases	Active export L2	kWh	Unsigned	R	0.01	0.01	0.1
931A	37658	4	1	Energies phases	Active export L3	kWh	Unsigned	R	0.01	0.01	0.1
931E	37662	4	1	Energies phases	Active net L1	kWh	Signed	R	0.01	0.01	-
9322	37666	4	1	Energies phases	Active net L2	kWh	Signed	R	0.01	0.01	-
9326	37670	4	1	Energies phases	Active net L3	kWh	Signed	R	0.01	0.01	-
932A	37674	4	1	Energies phases	Reactive import L1	kvarh	Unsigned	R	0.01	0.01	0.1
932E	37678	4	1	Energies phases	Reactive import L2	kvarh	Unsigned	R	0.01	0.01	0.1
9332	37682	4	1	Energies phases	Reactive import L3	kvarh	Unsigned	R	0.01	0.01	0.1
9336	37686	4	1	Energies phases	Reactive export L1	kvarh	Unsigned	R	0.01	0.01	0.1
933A	37690	4	1	Energies phases	Reactive export L2	kvarh	Unsigned	R	0.01	0.01	0.1
933E	37694	4	1	Energies phases	Reactive export L3	kvarh	Unsigned	R	0.01	0.01	0.1

Addr. (hex)	Addr. (dec)	Word (16-bit)	Slave Modbus ID	Category	Description	Unit	Format	Access	EQ Meter Resolution	M4M Res.	M2M Res.
9342	37698	4	1	Energies phases	Reactive net L1	kvarh	Signed	R	0.01	0.01	-
9346	37702	4	1	Energies phases	Reactive net L2	kvarh	Signed	R	0.01	0.01	-
934A	37706	4	1	Energies phases	Reactive net L3	kvarh	Signed	R	0.01	0.01	-
934E	37710	4	1	Energies phases	Apparent import L1	kVAh	Unsigned	R	0.01	0.01	0.1
9352	37714	4	1	Energies phases	Apparent import L2	kVAh	Unsigned	R	0.01	0.01	0.1
9356	37718	4	1	Energies phases	Apparent import L3	kVAh	Unsigned	R	0.01	0.01	0.1
935A	37722	4	1	Energies phases	Apparent export L1	kVAh	Unsigned	R	0.01	0.01	0.1
935E	37726	4	1	Energies phases	Apparent export L2	kVAh	Unsigned	R	0.01	0.01	0.1
9362	37730	4	1	Energies phases	Apparent export L3	kVAh	Unsigned	R	0.01	0.01	0.1
9366	37734	4	1	Energies phases	Apparent net L1	kVAh	Signed	R	0.01	0.01	-
936A	37738	4	1	Energies phases	Apparent net L2	kVAh	Signed	R	0.01	0.01	-
936E	37742	4	1	Energies phases	Apparent net L3	kVAh	Signed	R	0.01	0.01	-
9372	37746	4	1	Energies Resettable	Active import total	kWh	Unsigned	R	0.01	-	-
9376	37750	4	1	Energies Resettable	Active export total	kWh	Unsigned	R	0.01	-	-
937A	37754	4	1	Energies Resettable	Reactive import total	kvarh	Unsigned	R	0.01	-	-
937E	37758	4	1	Energies Resettable	Reactive export total	kvarh	Unsigned	R	0.01	-	-

Current and voltage harmonics up to 15th.

Addr. (hex)	Addr. (dec)	Word (16-bit)	Slave Modbus ID	Category	Description	Unit	Format	Access	EQ Meter Resolution	M4M Res.	M2M Res.
9382	37762	2	1	Harmonics	Voltage harmonics THD L1-N	%	Unsigned	R	0.1	0.1	0.1
9384	37764	2	1	Harmonics	Voltage harmonics THD L2-N	%	Unsigned	R	0.1	0.1	0.1
9386	37766	2	1	Harmonics	Voltage harmonics THD L3-N	%	Unsigned	R	0.1	0.1	0.1
9388	37768	1	1	Harmonics	Voltage harmonics 3rd L1-N	%	Unsigned	R	-	0.1	-
9389	37769	1	1	Harmonics	Voltage harmonics 3rd L2-N	%	Unsigned	R	-	0.1	-
938A	37770	1	1	Harmonics	Voltage harmonics 3rd L3-N	%	Unsigned	R	-	0.1	-
938B	37771	1	1	Harmonics	Voltage harmonics 5th L1-N	%	Unsigned	R	-	0.1	-
938C	37772	1	1	Harmonics	Voltage harmonics 5th L2-N	%	Unsigned	R	-	0.1	-
938D	37773	1	1	Harmonics	Voltage harmonics 5th L3-N	%	Unsigned	R	-	0.1	-
...	...	1	1	Harmonics	...	%	Unsigned	R	-	0.1	-
939A	37786	1	1	Harmonics	Voltage harmonics 15th L1-N	%	Unsigned	R	-	0.1	-
939B	37787	1	1	Harmonics	Voltage harmonics 15th L2-N	%	Unsigned	R	-	0.1	-
939C	37788	1	1	Harmonics	Voltage harmonics 15th L3-N	%	Unsigned	R	-	0.1	-
939D	37789	1	1	Harmonics	Voltage harmonics THD L1-L2	%	Unsigned	R	-	0.1	-
939E	37790	1	1	Harmonics	Voltage harmonics THD L3-L2	%	Unsigned	R	-	0.1	-

Addr. (hex)	Addr. (dec)	Word (16-bit)	Slave Modbus ID	Category	Description	Unit	Format	Access	EQ Meter Resolution	M4M Res.	M2M Res.
939F	37791	1	1	Harmonics	Voltage harmonics THD L1-L3	%	Unsigned	R	-	0.1	-
93A0	37792	1	1	Harmonics	Voltage harmonics 3rd L1-L2	%	Unsigned	R	-	0.1	-
93A1	37793	1	1	Harmonics	Voltage harmonics 3rd L3-L2	%	Unsigned	R	-	0.1	-
93A2	37794	1	1	Harmonics	Voltage harmonics 3rd L1-L3	%	Unsigned	R	-	0.1	-
93A3	37795	1	1	Harmonics	Voltage harmonics 5th L1-L2	%	Unsigned	R	-	0.1	-
93A4	37796	1	1	Harmonics	Voltage harmonics 5th L3-L2	%	Unsigned	R	-	0.1	-
93A5	37797	1	1	Harmonics	Voltage harmonics 5th L1-L3	%	Unsigned	R	-	0.1	-
...	...	1	1	Harmonics	...	%	Unsigned	R	-	0.1	-
93B2	37810	1	1	Harmonics	Voltage harmonics 15th L1-L2	%	Unsigned	R	-	0.1	-
93B3	37811	1	1	Harmonics	Voltage harmonics 15th L3-L2	%	Unsigned	R	-	0.1	-
93B4	37812	1	1	Harmonics	Voltage harmonics 15th L1-L3	%	Unsigned	R	-	0.1	-
93B5	37813	2	1	Harmonics	Current harmonics THD L1	%	Unsigned	R	0.1	0.1	0.1
93B7	37815	2	1	Harmonics	Current harmonics THD L2	%	Unsigned	R	0.1	0.1	0.1
93B9	37817	2	1	Harmonics	Current harmonics THD L3	%	Unsigned	R	0.1	0.1	0.1
93BB	37819	1	1	Harmonics	Current harmonics THD N	%	Unsigned	R	0.1	0.1	-
93BC	37820	1	1	Harmonics	Current harmonics 3rd L1	%	Unsigned	R	-	0.1	-
93BD	37821	1	1	Harmonics	Current harmonics 3rd L2	%	Unsigned	R	-	0.1	-
93BE	37822	1	1	Harmonics	Current harmonics 3rd L3	%	Unsigned	R	-	0.1	-
93BF	37823	1	1	Harmonics	Current harmonics 3rd N	%	Unsigned	R	-	0.1	-
93C0	37824	1	1	Harmonics	Current harmonics 5th L1	%	Unsigned	R	-	0.1	-
93C1	37825	1	1	Harmonics	Current harmonics 5th L2	%	Unsigned	R	-	0.1	-
93C2	37826	1	1	Harmonics	Current harmonics 5th L3	%	Unsigned	R	-	0.1	-
93C3	37827	1	1	Harmonics	Current harmonics 5th N	%	Unsigned	R	-	0.1	-
...	...	1	1	Harmonics	...	%	Unsigned	R	-	0.1	-
93D4	37844	1	1	Harmonics	Current harmonics 15th L1	%	Unsigned	R	-	0.1	-
93D5	37845	1	1	Harmonics	Current harmonics 15th L2	%	Unsigned	R	-	0.1	-
93D6	37846	1	1	Harmonics	Current harmonics 15th L3	%	Unsigned	R	-	0.1	-
93D7	37847	1	1	Harmonics	Current harmonics 15th N	%	Unsigned	R	-	0.1	-

I/O status and counter register

Addr. (hex)	Addr. (dec)	Word (16-bit)	Slave Modbus ID	Category	Description	Unit	Format	Access	EQ Meter Resolution	M4M Res.	M2M Res.
93D8	37848	8	1	I/O	Analogue outputs 1-2	-	Unsigned	R	-	1	-
93E0	37856	4	1	I/O	Output 5-6	-	Unsigned	R	-	1	-
93E4	37860	4	1	I/O	Input 1 Counter	-	Unsigned	R	1	1	-
93E8	37864	4	1	I/O	Input 2 Counter	-	Unsigned	R	1	1	-
93EC	37868	4	1	I/O	Input 3 Counter	-	Unsigned	R	1	1	-
93F0	37872	4	1	I/O	Input 4 Counter	-	Unsigned	R	1	1	-
93F4	37876	4	1	I/O	Input 5-6 Counter	-	Unsigned	R	-	1	-

Addr. (hex)	Addr. (dec)	Word (16-bit)	Slave Modbus ID	Category	Description	Unit	Format	Access	EQ Meter Resolution	M4M Res.	M2M Res.
93F8	37880	2	1	I/O	AVER. ACTIVE POWER from PULSES INPUT (CH1)	-	Unsigned long	R	-	-	1
93FA	37882	2	1	I/O	AVER. REACT. POWER from PULSES INPUT (CH2)	-	Unsigned long	R	-	-	1
93FC	37884	2	1	I/O	ACTIVE ENERGY from PULSES INPUT (CH1)	-	Unsigned long	R	-	-	1
93FE	37886	2	1	I/O	REACTIVE ENERGY from PULSES INPUT (CH2)	-	Unsigned long	R	-	-	1
9400	37888	1	1	I/O	Output 1	-	Unsigned	R	1	1	-
9401	37889	1	1	I/O	Output 2	-	Unsigned	R	1	1	-
9402	37890	1	1	I/O	Output 3	-	Unsigned	R	1	1	-
9403	37891	1	1	I/O	Output 4	-	Unsigned	R	1	1	-
9404	37892	1	1	I/O	Input 1 Current state	-	Unsigned	R	1	1	-
9405	37893	1	1	I/O	Input 2 Current state	-	Unsigned	R	1	1	-
9406	37894	1	1	I/O	Input 3 Current state	-	Unsigned	R	1	1	-
9407	37895	1	1	I/O	Input 4 Current state	-	Unsigned	R	1	1	-
9408	37896	1	1	I/O	Input 5-6 Current state	-	Unsigned	R	-	1	-
9409	37897	1	1	I/O	Input 1 Stored	-	Unsigned	R	1	1	-
940A	37898	1	1	I/O	Input 2 Stored	-	Unsigned	R	1	1	-
940B	37899	1	1	I/O	Input 3 Stored	-	Unsigned	R	1	1	-
940C	37900	1	1	I/O	Input 4 Stored	-	Unsigned	R	1	1	-
940D	37901	1	1	I/O	Input 5-6 Stored	-	Unsigned	R	-	1	-

Instantaneous values

Addr. (hex)	Addr. (dec)	Word (16-bit)	Slave Modbus ID	Category	Description	Unit	Format	Access	EQ Meter Resolution	M4M Res.	M2M Res.
940E	37902	2	1	Instantaneous	Voltages L1	V	Unsigned	R	0.1	0.1	1
9410	37904	2	1	Instantaneous	Voltages L2	V	Unsigned	R	0.1	0.1	1
9412	37906	2	1	Instantaneous	Voltages L3	V	Unsigned	R	0.1	0.1	1
9414	37908	2	1	Instantaneous	Voltages L1-L2	V	Unsigned	R	0.1	0.1	1
9416	37910	2	1	Instantaneous	Voltages L3-L2	V	Unsigned	R	0.1	0.1	1
9418	37912	2	1	Instantaneous	Voltages L1-L3	V	Unsigned	R	0.1	0.1	1
941A	37914	2	1	Instantaneous	Three phase system voltage	V	Unsigned	R	-	1	1
941C	37916	2	1	Instantaneous	Currents L1	A	Unsigned	R	0.01	0.01	0.001
941E	37918	2	1	Instantaneous	Currents L2	A	Unsigned	R	0.01	0.01	0.001
9420	37920	2	1	Instantaneous	Currents L3	A	Unsigned	R	0.01	0.01	0.001
9422	37922	2	1	Instantaneous	Currents N	A	Unsigned	R	0.01	0.01	-
9424	37924	2	1	Instantaneous	Three phase system current	A	Unsigned	R	-	1	1
9426	37926	2	1	Instantaneous	Active Power Total	W	Signed	R	0.01	0.01	1
9428	37928	2	1	Instantaneous	Active Power L1	W	Signed	R	0.01	0.01	1
942A	37930	2	1	Instantaneous	Active Power L2	W	Signed	R	0.01	0.01	1
942C	37932	2	1	Instantaneous	Active Power L3	W	Signed	R	0.01	0.01	1

Addr. (hex)	Addr. (dec)	Word (16-bit)	Slave Modbus ID	Category	Description	Unit	Format	Access	EQ Meter Resolution	M4M Res.	M2M Res.
942E	37934	2	1	Instantaneous	Reactive Power Total	var	Signed	R	0.01	0.01	1
9430	37936	2	1	Instantaneous	Reactive Power L1	var	Signed	R	0.01	0.01	1
9432	37938	2	1	Instantaneous	Reactive Power L2	var	Signed	R	0.01	0.01	1
9434	37940	2	1	Instantaneous	Reactive Power L3	var	Signed	R	0.01	0.01	1
9436	37942	2	1	Instantaneous	Apparent Power Total	VA	Unsigned	R	0.01	0.01	1
9438	37944	2	1	Instantaneous	Apparent Power L1	VA	Unsigned	R	0.01	0.01	1
943A	37946	2	1	Instantaneous	Apparent Power L2	VA	Unsigned	R	0.01	0.01	1
943C	37948	2	1	Instantaneous	Apparent Power L3	VA	Unsigned	R	0.01	0.01	1
943E	37950	2	1	Instantaneous	Cos phi 3-phase	-	Signed long	R	-	1	1
9440	37952	2	1	Instantaneous	Cos phi L1	-	Signed long	R	-	1	0.001
9442	37954	2	1	Instantaneous	Cos phi L2	-	Signed long	R	-	1	0.001
9444	37956	2	1	Instantaneous	Cos phi L3	-	Signed long	R	-	1	0.001
9446	37958	2	1	Instantaneous	Frequency	Hz	Unsigned	R	0.01	0.01	0.001
9448	37960	1	1	Instantaneous	Phase angle Power Total	deg	Signed	R	0.1	0.1	-
9449	37961	1	1	Instantaneous	Phase angle Power L1	deg	Signed	R	0.1	0.1	-
944A	37962	1	1	Instantaneous	Phase angle Power L2	deg	Signed	R	0.1	0.1	-
944B	37963	1	1	Instantaneous	Phase angle Power L3	deg	Signed	R	0.1	0.1	-
944C	37964	1	1	Instantaneous	Phase angle Voltage L1	deg	Signed	R	0.1	0.1	-
944D	37965	1	1	Instantaneous	Phase angle Voltage L2	deg	Signed	R	0.1	0.1	-
944E	37966	1	1	Instantaneous	Phase angle Voltage L3	deg	Signed	R	0.1	0.1	-
944F	37967	1	1	Instantaneous	Phase angle Voltage L1-L2	deg	Signed	R	-	0.1	-
9450	37968	1	1	Instantaneous	Phase angle Voltage L3-L2	deg	Signed	R	-	0.1	-
9451	37969	1	1	Instantaneous	Phase angle Voltage L1-L3	deg	Signed	R	-	0.1	-
9452	37970	1	1	Instantaneous	Phase angle Current L1	deg	Signed	R	0.1	0.1	-
9453	37971	1	1	Instantaneous	Phase angle Current L2	deg	Signed	R	0.1	0.1	-
9454	37972	1	1	Instantaneous	Phase angle Current L3	deg	Signed	R	0.1	0.1	-
9455	37973	2	1	Instantaneous	Power factor Total	-	Signed	R	0.001	0.001	0.001
9457	37975	2	1	Instantaneous	Power factor L1	-	Signed	R	0.001	0.001	0.001
9459	37977	2	1	Instantaneous	Power factor L2	-	Signed	R	0.001	0.001	0.001
945B	37979	2	1	Instantaneous	Power factor L3	-	Signed	R	0.001	0.001	0.001
945D	37981	1	1	Instantaneous	Current quadrant Total	-	Unsigned	R	1	1	-
945E	37982	1	1	Instantaneous	Current quadrant L1	-	Unsigned	R	1	1	-
945F	37983	1	1	Instantaneous	Current quadrant L2	-	Unsigned	R	1	1	-
9460	37984	1	1	Instantaneous	Current quadrant L3	-	Unsigned	R	1	1	-

Maximum values

Addr. (hex)	Addr. (dec)	Word (16-bit)	Slave Modbus ID	Category	Description	Unit	Format	Access	EQ Meter Resolution	M4M Res.	M2M Res.
9461	37985	2	1	Maximum values	MAX LINE CURRENT L1	mA	Unsigned long	R	-	-	1
9463	37987	2	1	Maximum values	MAX LINE CURRENT L2	mA	Unsigned long	R	-	-	1
9465	37989	2	1	Maximum values	MAX LINE CURRENT L3	mA	Unsigned long	R	-	-	1
9467	37991	2	1	Maximum values	MAX 3-PHASE SYS. ACTIVE POWER	W	Signed long	R	-	-	1
9469	37993	2	1	Maximum values	MAX 3-PHASE S. APPARENT POWER	VA	Signed long	R	-	-	1
946B	37995	2	1	Maximum values	MAX 3-PHASE SYS. ACTIVE POWER 15' AVER	W	Signed long	R	-	-	1
946D	37997	2	1	Maximum values	MAX ACTIVE POWER 15' AVER L1	W	Signed long	R	-	-	1
946F	37999	2	1	Maximum values	MAX ACTIVE POWER 15' AVER L2	W	Signed long	R	-	-	1
9471	38001	2	1	Maximum values	MAX ACTIVE POWER 15' AVER L3	W	Signed long	R	-	-	1
9473	38003	2	1	Maximum values	MAX 3-PHASE SYS. APPARENT POWER 15' AVER	VA	Unsigned long	R	-	-	1
9475	38005	2	1	Maximum values	MAX APPARENT POWER 15' AVER L1	VA	Unsigned long	R	-	-	1
9477	38007	2	1	Maximum values	MAX APPARENT POWER 15' AVER L2	VA	Unsigned long	R	-	-	1
9479	38009	2	1	Maximum values	MAX APPARENT POWER 15' AVER L3	VA	Unsigned long	R	-	-	1

Reset operations

Addr. (hex)	Addr. (dec)	Word (16-bit)	Slave Modbus ID	Category	Description	Unit	Format	Access	EQ Meter Resolution	M4M Res.	M2M Res.
947B	38011	8	1	Operations	Reset tariff registers Tariff quantity 1..8 All tariff Registers	-	Unsigned	R/W	1	1	-
9483	38019	5	1	Operations	Reset power fail counter All, L1..L3, Any	-	Unsigned	R/W	1	1	-
9488	38024	5	1	Operations	Reset power outage time All, L1..L3, Any	-	Unsigned	R/W	1	1	-
948D	38029	4	1	Operations	Reset input 5-8 counters	-	Unsigned	R/W	1	1	-
9491	38033	4	1	Operations	Reset stored states Input 5-8	-	Unsigned	R/W	1	1	-
9495	38037	1	1	Operations	Reset input 1 counters	-	Unsigned	R/W	1	1	-
9496	38038	1	1	Operations	Reset input 2 counters	-	Unsigned	R/W	1	1	-
9497	38039	1	1	Operations	Reset input 3 counters	-	Unsigned	R/W	1	1	-
9498	38040	1	1	Operations	Reset input 4 counters	-	Unsigned	R/W	1	1	-
9499	38041	1	1	Operations	Reset stored states Input 1	-	Unsigned	R/W	1	1	-
949A	38042	1	1	Operations	Reset stored states Input 2	-	Unsigned	R/W	1	1	-
949B	38043	1	1	Operations	Reset stored states Input 3	-	Unsigned	R/W	1	1	-

Addr. (hex)	Addr. (dec)	Word (16-bit)	Slave Modbus ID	Category	Description	Unit	Format	Access	EQ Meter Resolution	M4M Res.	M2M Res.
949C	38044	1	1	Operations	Reset stored states Input 4	-	Unsigned	R/W	1	1	-
949D	38045	1	1	Operations	Reset active energy import Resettable energy reg	-	Unsigned	R/W	1	1	-
949E	38046	1	1	Operations	Reset active energy export Resettable energy reg	-	Unsigned	R/W	1	1	-
949F	38047	1	1	Operations	Reset reactive energy import Resettable energy reg	-	Unsigned	R/W	1	1	-
94A0	38048	1	1	Operations	Reset reactive energy export Resettable energy reg	-	Unsigned	R/W	1	1	-
94A1	38049	1	1	Operations	Reset Previous values All channels	-	Unsigned	R/W	1	1	-
94A2	38050	1	1	Operations	Reset Demand All channels	-	Unsigned	R/W	1	1	-
94A3	38051	1	1	Operations	Reset Load profile channel 1	-	Unsigned	R/W	-	1	-
94A4	38052	1	1	Operations	Reset Load profile channel 2	-	Unsigned	R/W	-	1	-
94A5	38053	1	1	Operations	Reset Load profile channel 3	-	Unsigned	R/W	-	1	-
94A6	38054	1	1	Operations	Reset Load profile channel 4	-	Unsigned	R/W	-	1	-
94A7	38055	1	1	Operations	Reset Load profile channel 5	-	Unsigned	R/W	-	1	-
94A8	38056	1	1	Operations	Reset Load profile channel 6	-	Unsigned	R/W	-	1	-
94A9	38057	1	1	Operations	Reset Load profile channel 7	-	Unsigned	R/W	-	1	-
94AA	38058	1	1	Operations	Reset Load profile channel 8	-	Unsigned	R/W	-	1	-
94AB	38059	1	1	Operations	Reset System log	-	Unsigned	R/W	1	1	-
94AC	38060	1	1	Operations	Reset Event log	-	Unsigned	R/W	1	1	-
94AD	38061	1	1	Operations	Reset Net quality log	-	Unsigned	R/W	1	1	-
94AE	38062	1	1	Operations	Reset Communication log	-	Unsigned	R/W	1	1	-
94AF	38063	1	1	Operations	Reset maintenance timer	-	Unsigned	R/W	1	1	-
94B0	38064	1	1	Operations	Freeze Demand	-	Unsigned	R/W	1	1	-

Miscellaneous info and settings

Addr. (hex)	Addr. (dec)	Word (16-bit)	Slave Modbus ID	Category	Description	Unit	Format	Access	EQ Meter Resolution	M4M Res.	M2M Res.
94B1	38065	15	1	Other	Power outage time(s)	-	Unsigned	R	1	1	-
94C0	38080	5	1	Other	Power fail counters	-	Unsigned	R	1	1	-
94C5	38085	4	1	Other	Current tariff (1-4)	-	Unsigned	R/W	1	1	-
94C9	38089	4	1	Other	Current tariff (5-8)	-	Unsigned	R/W	1	1	1
94CD	38093	4	1	Other	Error flags	-	Unsigned	R	1	1	-
94D1	38097	4	1	Other	Information flags	-	Unsigned	R	1	1	-
94D5	38101	4	1	Other	Warning flags	-	Unsigned	R	1	1	-
94D9	38105	4	1	Other	Alarm flags	-	Unsigned	R	1	1	-
94DD	38109	4	1	Other	Reset counter (resettable active energy import)	-	Unsigned	R	1	1	-

Addr. (hex)	Addr. (dec)	Word (16-bit)	Slave Modbus ID	Category	Description	Unit	Format	Access	EQ Meter Resolution	M4M Res.	M2M Res.
94E1	38113	4	1	Other	Reset counter (resettable active energy export)	-	Unsigned	R	1	1	-
94E5	38117	4	1	Other	Reset counter (resettable reactive energy import)	-	Unsigned	R	1	1	-
94E9	38121	4	1	Other	Reset counter (resettable reactive energy export)	-	Unsigned	R	1	1	-
94ED	38125	3	1	Other	Date Time YYMMDD:HHMMSS	-	Unsigned	R/W	1	1	-
94F0	38128	2	1	Other	CURRENT THRESHOLD for TIMER-2 ACTIVATION	mA	Unsigned long	R	-	-	1
94F2	38130	2	1	Other	PULSE ENERGY WEIGHT	-	Unsigned long	R/W	-	-	1
94F4	38132	1	1	Other	Day of week	-	Unsigned	R	1	1	-
94F5	38133	1	1	Other	DST active	-	Unsigned	R	1	1	-
94F6	38134	1	1	Other	Active day type	-	Unsigned	R	1	1	-
94F7	38135	1	1	Other	Active season	-	Unsigned	R	1	1	-

Device information

Addr. (hex)	Addr. (dec)	Word (16-bit)	Slave Modbus ID	Category	Description	Unit	Format	Access	EQ Meter Resolution	M4M Res.	M2M Res.
94F8	38136	8	1	Production data	Meter firmware version	text	String	R	1	1	-
9500	38144	8	1	Production data	Slave ID	-	Unsigned	R	-	1	-
9508	38152	8	1	Production data	Logical device name	text	String	R	-	1	-
9510	38160	6	1	Production data	Type designation	text	String	R	1	1	-
9516	38166	5	1	Production data	Serial number(s)	-	Unsigned	R	1	1	-
951B	38171	1	1	Production data	Modbus mapping version	-	Unsigned	R	1	1	-

Device settings

Addr. (hex)	Addr. (dec)	Word (16-bit)	Slave Modbus ID	Category	Description	Unit	Format	Access	EQ Meter Resolution	M4M Res.	M2M Res.
951C	38172	2	1	Settings	1st reg: Actions, 2nd reg: output nr On/Off delay	-	Unsigned	R/W	-	1	-
951E	38174	4	1	Settings	Complex Alarms Components	-	Unsigned	R/W	-	1	-
9522	38178	3	1	Settings	I/O settings (incl pulse outputs) Energy quantity OBIS code	-	Unsigned	R/W	1	1	1
9525	38181	3	1	Settings	Load profile settings Quantity OBIS code	-	Unsigned	R/W	-	1	-
9528	38184	3	1	Settings	Demand settings Channel quantity OBIS code	-	Unsigned	R/W	-	1	-
952B	38187	3	1	Settings	Demand settings Level quantity OBIS code	-	Unsigned	R/W	-	1	-
952E	38190	3	1	Settings	Alarm settings Quantity OBIS	-	Unsigned	R/W	-	1	-

Addr. (hex)	Addr. (dec)	Word (16-bit)	Slave Modbus ID	Category	Description	Unit	Format	Access	EQ Meter Resolution	M4M Res.	M2M Res.
9531	38193	2	1	Settings	Current transformer ratio secondary current	-	Unsigned	R/W	1	1	-
9533	38195	2	1	Settings	Voltage transformer ratio secondary current	-	Unsigned	R/W	1	1	-
9535	38197	2	1	Settings	Neutral current transf ratio (Numerator)	-	Unsigned	R/W	-	1	-
9537	38199	2	1	Settings	Neutral current transf ratio (Denominator)	-	Unsigned	R/W	-	1	-
9539	38201	2	1	Settings	Current transformer ratio	-	Unsigned	R/W	-	-	1
953B	38203	2	1	Settings	Voltage transformer ratio	-	Unsigned long	R/W	-	-	1
953D	38205	2	1	Settings	I/O settings (incl pulse outputs) Pulses / kWh	-	Unsigned	R/W	1	1	1
953F	38207	2	1	Settings	I/O settings (incl pulse outputs) Pulses / kvarh	-	Unsigned	R/W	1	1	1
9541	38209	2	1	Settings	I/O settings (incl pulse outputs) Pulse length (ms)	-	Unsigned	R/W	1	1	1
9543	38211	2	1	Settings	Load profile settings Period	-	Unsigned	R/W	-	1	-
9545	38213	2	1	Settings	Load profile settings Channel entries	-	Unsigned	R/W	-	1	-
9547	38215	2	1	Settings	Actions registers: On/Off thresholds	-	Unsigned	R/W	-	1	-
9549	38217	2	1	Settings	Actions: bit0=log, bit1=output, bit2=reg. Alarm action on/off	-	Unsigned	R/W	-	1	-
954B	38219	2	1	Settings	Complex Alarms Actions	-	Unsigned	R/W	-	1	-
954D	38221	2	1	Settings	CO2 conversion factor act energy	-	Unsigned	R/W	0.001	1	-
954F	38223	2	1	Settings	Currency conversion factor act en.	-	Unsigned	R/W	0.01	1	-
9551	38225	2	1	Settings	DST start (month, day of month, day of week, hour)	-	Unsigned	R/W	1	1	-
9553	38227	2	1	Settings	DST end (month, day of month, day of week, hour)	-	Unsigned	R/W	1	1	-
9555	38229	1	1	Settings	Current transformer ratio primary current	-	Unsigned	R/W	1	1	-
9556	38230	1	1	Settings	Voltage transformer ratio primary voltage	-	Unsigned	R/W	1	1	-
9557	38231	1	1	Settings	I/O settings (incl pulse outputs) I/O signal mode port 1	-	Unsigned	R/W	-	1	-
9558	38232	1	1	Settings	I/O settings (incl pulse outputs) I/O signal mode port 2	-	Unsigned	R/W	-	1	-
9559	38233	1	1	Settings	I/O settings (incl pulse outputs) I/O signal mode port 3	-	Unsigned	R/W	-	1	-

Addr. (hex)	Addr. (dec)	Word (16-bit)	Slave Modbus ID	Category	Description	Unit	Format	Access	EQ Meter Resolution	M4M Res.	M2M Res.
955A	38234	1	1	Settings	I/O settings (incl pulse outputs) I/O signal mode port 4	-	Unsigned	R/W	-	1	-
955B	38235	1	1	Settings	I/O settings (incl pulse outputs) I/O signal mode port 5	-	Unsigned	R/W	-	1	-
955C	38236	1	1	Settings	I/O settings (incl pulse outputs) I/O signal mode port 6	-	Unsigned	R/W	-	1	-
955D	38237	1	1	Settings	I/O settings (incl pulse outputs) Instance nr (1-6)	-	Unsigned	R/W	-	1	-
955E	38238	1	1	Settings	I/O settings (incl pulse outputs) I/O nr (port nr) (1-6)	-	Unsigned	R/W	1	1	1
955F	38239	1	1	Settings	I/O settings (incl pulse outputs) Turn off pulse output	-	Unsigned	R/W	-	1	-
9560	38240	1	1	Settings	Load profile settings Channel nr (1-8)	-	Unsigned	R/W	-	1	-
9561	38241	1	1	Settings	Load profile settings Search type Raw=0, Smart=1	-	Unsigned	R/W	-	1	-
9562	38242	1	1	Settings	Demand settings Nr of quantities - start config	-	Unsigned	R/W	-	1	-
9563	38243	1	1	Settings	Demand settings Channel nr (R only) auto updated	-	Unsigned	R/W	-	1	-
9564	38244	1	1	Settings	Demand settings Levels	-	Unsigned	R/W	-	1	-
9565	38245	1	1	Settings	Demand settings Interval (minutes)	-	Unsigned	R/W	-	1	-
9566	38246	1	1	Settings	Demand settings Sub interval (minutes)	-	Unsigned	R/W	-	1	-
9567	38247	1	1	Settings	MSB: 0=Da,1=We, 2=Mo,LSB:1=mon, 7=sun Period (day/week/month + week day)	-	Unsigned	R/W	-	1	-
9568	38248	1	1	Settings	Alarm settings Channel nr (1-25)	-	Unsigned	R/W	-	1	-
9569	38249	1	1	Settings	Hysteresis	-	Unsigned	R/W	-	1	-
956A	38250	1	1	Settings	Type 0=None;1cross up;2-cross down	-	Unsigned	R/W	-	1	-
956B	38251	1	1	Settings	Complex Alarms Channel nr	-	Unsigned	R/W	-	1	-
956C	38252	1	1	Settings	Complex Alarms Operators	-	Unsigned	R/W	-	1	-
956D	38253	1	1	Settings	LED source 0 = Active energy, 1 = Reactive energy	-	Unsigned	R/W	1	1	-
956E	38254	1	1	Settings	Number of elements 1-3	-	Unsigned	R	1	-	-
956F	38255	1	1	Settings	DST enabled (0 = disabled, 1 = enabled)	-	Unsigned	R/W	1	1	-

Total active, reactive and apparent energy (import, export and net)

Addr. (hex)	Addr. (dec)	Word (16-bit)	Slave Modbus ID	Category	Description	Unit	Format	Access	EQ Meter Resolution	M4M Res.	M2M Res.
9570	38256	4	1	Total energies	Active import	kWh	Unsigned	R	0.01	0.01	0.1
9574	38260	4	1	Total energies	Active export	kWh	Unsigned	R	0.01	0.01	0.1
9578	38264	4	1	Total energies	Active net	kWh	Signed	R	0.01	0.01	-
957C	38268	4	1	Total energies	Reactive import	kvarh	Unsigned	R	0.01	0.01	0.1
9580	38272	4	1	Total energies	Reactive export	kvarh	Unsigned	R	0.01	0.01	0.1
9584	38276	4	1	Total energies	Reactive net	kvarh	Signed	R	0.01	0.01	-
9588	38280	4	1	Total energies	Apparent import	kVAh	Unsigned	R	0.01	0.01	0.1
958C	38284	4	1	Total energies	Apparent export	kVAh	Unsigned	R	0.01	0.01	0.1
9590	38288	4	1	Total energies	Apparent net	kVAh	Signed	R	0.01	0.01	-
9594	38292	2	1	Total energies	3PHASE SYS. ACTIVE POWER 15' AVER	W	Unsigned long	R	-	1	1
9596	38294	2	1	Total energies	3PHASE SYS. APPARENT POWER 15' AVER	VA	Unsigned long	R	-	1	1

Unbalances voltage and current

Addr. (hex)	Addr. (dec)	Word (16-bit)	Slave Modbus ID	Category	Description	Unit	Format	Access	EQ Meter Resolution	M4M Res.	M2M Res.
9598	38296	2	1	Unbalances	Unbalances Phase voltage	%	Unsigned	R	-	0.1	-
959A	38298	2	1	Unbalances	Unbalances Line voltage	%	Unsigned	R	-	1	-
959C	38300	2	1	Unbalances	Unbalances Current	%	Unsigned	R	-	0.1	-

Naming, status and counters of ports of IO module with ID = 97

Addr. (hex)	Addr. (dec)	Word (16-bit)	Slave Modbus ID	Category	Description	Unit	Format	Access
E486	58502	1	97	IO module	I/O configuration	-	Unsigned	R/W
E487	58503	2	97	IO module	Pulse Counter Port 0	-	Unsigned	R
E489	58505	2	97	IO module	Pulse Counter Port 1	-	Unsigned	R
E48B	58507	2	97	IO module	Pulse Counter Port 2	-	Unsigned	R
E48D	58509	2	97	IO module	Pulse Counter Port 3	-	Unsigned	R
E48F	58511	1	97	IO module	Status Contacts Port 0	-	Unsigned	R/W
E490	58512	1	97	IO module	Status Contacts Port 1	-	Unsigned	R/W
E491	58513	1	97	IO module	Status Contacts Port 2	-	Unsigned	R/W
E492	58514	1	97	IO module	Status Contacts Port 3	-	Unsigned	R/W
E493	58515	2	97	IO module	Pulse value Port 0	-	Unsigned (yet unsup.)	R
E495	58517	2	97	IO module	Pulse value Port 1	-	Unsigned (yet unsup.)	R
E497	58519	2	97	IO module	Pulse value Port 2	-	Unsigned (yet unsup.)	R
E499	58521	2	97	IO module	Pulse value Port 3	-	Unsigned (yet unsup.)	R
E49B	58523	3	97	IO module	Pulse unit Port 0	-	String	R
E49E	58526	3	97	IO module	Pulse unit Port 1	-	String	R
E4A1	58529	3	97	IO module	Pulse unit Port 2	-	String	R
E4A4	58532	3	97	IO module	Pulse unit Port 3	-	String	R
E4A7	58535	8	97	IO module	Pulse medium Port 0	-	String (yet unsup.)	R

Addr. (hex)	Addr. (dec)	Word (16-bit)	Slave Modbus ID	Category	Description	Unit	Format	Access
E4AF	58543	8	97	IO module	Pulse medium Port 1	-	String (yet unsup.)	R
E4B7	58551	8	97	IO module	Pulse medium Port 2	-	String (yet unsup.)	R
E4BF	58559	8	97	IO module	Pulse medium Port 3	-	String (yet unsup.)	R
E4C7	58567	15	97	IO module	Tag Name Port 0	text	String	R
E4D6	58582	15	97	IO module	Tag Name Port 1	text	String	R
E4E5	58597	15	97	IO module	Tag Name Port 2	text	String	R
E4F4	58612	15	97	IO module	Tag Name Port 3	text	String	R
E503	58627	15	97	IO module	Module Tag Name	text	String	R
E512	58642	4	97	IO module	SID of the module	-	Unsigned long	R
E516	58646	1	97	IO module	Alarm status Port 0	-	Unsigned (yet unsupported)	R
E517	58647	1	97	IO module	Alarm status Port 1	-	Unsigned (yet unsupported)	R
E518	58648	1	97	IO module	Alarm status Port 2	-	Unsigned (yet unsupported)	R
E519	58649	1	97	IO module	Alarm status Port 3	-	Unsigned (yet unsupported)	R
E51A	58650	1	97	IO module	Alarm status module	-	Unsigned (yet unsupported)	R



For the complete Modbus and SNMP map please refer to the one available for downloading on the ABB InSite pro M compact webpage



ABB S.p.A

Electrification business
Viale dell'Industria, 18
20009 Vittuone (MI) Italy
new.abb.com/low-voltage

