

Regulations Concerning the Setting up of Installations

Apart from the basic "Regulations for the Setting up of Power Installations" DIN VDE* 0100 and for "The Rating of Creepage Distances and Clearances" DIN VDE 0110 Part 1 and Part 2 the regulations "The Equipment of Power Installations with Electrical Components" DIN VDE 0160 in conjunction with DIN VDE 0660 Part 500 have to be taken into due consideration.

Further attention has to be paid to DIN VDE 0113 Part 1 and Part 200 in case of the control of working and processing machines. If operating elements are to be mounted near parts with dangerous contact voltage DIN VDE 0106 Part 100 is additionally relevant.

If the protection against direct contact according to DIN VDE 0160 is required, this has to be ensured by the user (e.g. by incorporating the elements in a switch-gear cabinet). The devices are designed for pollution severity 2 in accordance with DIN VDE 0110 Part 1. If higher pollution is expected, the devices must be installed in appropriate housings.

The user has to guarantee that the devices and the components belonging to them are mounted following these regulations. For operating the machines and installations, other national and international relevant regulations, concerning prevention of accidents and using technical working means, also have to be met.

The Advant Controller 31 (AC31) standard devices are designed according to IEC 1131 Part 2. Meeting this regulation, they are classified in overvoltage category II which is in conformance with DIN VDE 0110 Part 2.

For the direct connection of AC31 devices, which are powered with or coupled to AC line voltages of overvoltage category III, appropriate protection measures corresponding to overvoltage category II according to IEC-Report 664/1980 and DIN VDE 0110 Part 1 are to install.

Equivalent standards:

DIN VDE 0110 Part 1 corresponds to IEC 664
DIN VDE 0113 Part 1 corresponds to EN 60204 Part 1
DIN VDE 0660 Part 500 corresponds to EN 60439-1
corresponds to IEC 439-1

The safety-related checklist has to be fulfilled. System operation is only allowed when the switch cabinet is closed.

All rights reserved to change design, figures, size, weight, prices etc.

* VDE stands for "Association of German Electrical Engineers".

3 Central unit 07 KT 93-S

Central unit with max. 56 kB user program + 30 kB user data

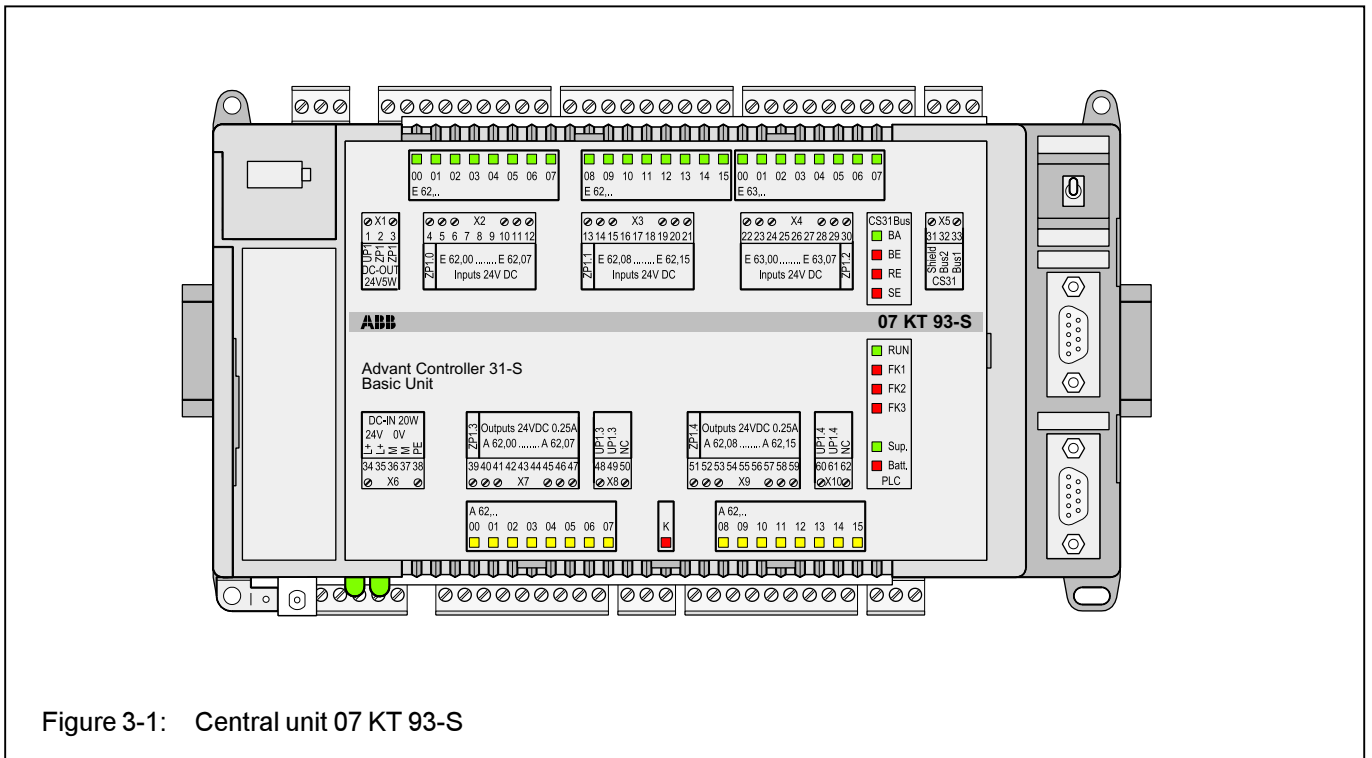

Figure 3-1: Central unit 07 KT 93-S

Contents

3.1 Brief description	3-2	3.4.10 Serial interface COM1	3-14
3.1.1 Main features	3-2	3.4.11 Serial interface COM2	3-15
3.1.2 Project planning / start-up	3-2	3.4.12 Networking interface	3-16
3.2 Overall view	3-4	3.5 High-speed counter	3-17
3.3 Structure of the front panel	3-5	3.6 Technical data	3-20
3.3.1 Terminal assignment overview	3-6	3.6.1 General data	3-20
3.4 Electrical connection	3-7	3.6.2 Power supply	3-20
3.4.1 Application example for input and output wiring	3-7	3.6.3 24 V output voltage for the supply of inputs	3-21
3.4.2 Connecting the supply voltage	3-8	3.6.4 Lithium battery	3-21
3.4.3 Electrical isolation and notes on earthing	3-9	3.6.5 Binary inputs	3-21
3.4.4 ARCNET interface	3-10	3.6.6 Binary outputs	3-21
3.4.5 Connection for CS31 system bus	3-10	3.6.7 Connection of serial interface COM1	3-22
3.4.6 24 V output voltage for the signal supply of the inputs	3-11	3.6.8 Connection of serial interface COM2	3-22
3.4.7 Connection of the binary inputs	3-11	3.6.9 Connection to the CS31 system bus	3-23
3.4.8 Connection of the binary outputs	3-12	3.6.10 Connection to ARCNET	3-23
3.4.9 Battery and battery replacement	3-13	3.6.11 LED displays	3-23
		3.6.12 High-speed hardware counter	3-23
		3.6.13 Mechanical data	3-24
		3.6.14 Mounting hints	3-24
		3.6.15 Ordering data	3-25

3.1 Brief description

The central unit 07 KT 93-S works either as

- bus master in the decentralized automation system Advant Controller 31-S or as
- slave (remote processor) in the decentralized automation system Advant Controller 31-S or as
- stand-alone central unit.

The device has a 24 V DC power supply voltage. It is provided with an additional interface for connecting communication modules (e.g. 07 KP 90).

The central unit 07 KT 93-S is equipped with an **integrated ARCNET coupler** (and an ARCNET interface).

3.1.1 Main features

- 24 binary inputs
- 16 binary transistor outputs
- 1 counting input for counting frequencies up to 10 kHz
- 1 CS31 system bus interface for system expansion
- Serial interface COM1
 - is set as programming interface
 - can be set as an ASCII interface for connecting peripheral devices (e.g. MMC devices)
- Serial interface COM2 as a MMC interface
- Networking interface for ABB communication devices
- ARCNET coupler / ARCNET interface
- Real-time clock
- LEDs for displaying the binary input and output signals as well as operating conditions and error messages
- Detachable screw-type terminal blocks
- Fastening by screws or by snapping the device onto a DIN rail
- The lithium battery 07 LE 90 can be put into the battery compartment in order to
 - store and back-up the user program in the RAM
 - store and back-up data which is additionally contained in the RAM, e.g. the status of flags
 - back-up the time and date (real-time clock).
- RUN/STOP switch for starting and aborting the program execution.
- Extensive diagnosis functions
 - Self-diagnosis of the central unit
 - Diagnosis of the CS31 system bus and the connected modules

Note:

The binary inputs and outputs, the networking interface and the ARCNET interface may not be used for the transfer of safety-related data. Safety-related data are read in and put out only via special safety-related I/O modules on the CS31 system bus.

3.1.2 Project planning / start-up

The following has to be observed for project planning and start-up:

- Programming is performed using ABB programming software, which can be run on commercially available IBM compatible PCs (see documentation for the programming system 907 PC 331).
- The instructions given in the safety manual 907 PC 338 must be observed for the design of the safety-related user program.
- The processor processes the user program contained in the RAM. It is loaded into the RAM via the serial interface COM1 and can also be changed there. An additional save command is used to save the program in the Flash EPROM.

Note:

In the course of the following operations

- Power 'ON'
- RUN/STOP switch from STOP -> RUN
- Program start-up with programming system
- Cold start of the PLC

the RAM is overwritten by the contents of the Flash EPROM, if an user program is contained in the Flash EPROM.

- Online program modification
The two existing RAMs allow a quick modification of the user program to be performed without interrupting the operation (see ABB programming system 907 PC 331).
- Change-over between the application modes
 - Stand-alone central unit
 - Bus master central unit and
 - Slave central unit

The central unit is set to "Stand-alone" upon delivery. Changing the application mode is carried out in the following three steps:

1. Change the system constant KW 00,00 in the PLC, see chapter A7.3 (Appendix), System constants
2. Save the user program in the Flash EPROM
3. Activate new PLC application mode by:
 - calling up the menu item "Enable PLC mode" in the ABB programming and test system or
 - performing a warm start or
 - performing a cold start.

- Setting the cycle time
see chapter A1 (Appendix), Processing times
- Addressing when remote modules are connected
see chapter A2 (Appendix), Addressing
- Back-up of data areas
Back-up (buffering) of data areas, i.e. saving of data during power OFF/ON, is only feasible with built-in battery. The following data can be buffered, completely or partly:
 - Binary flags
 - Word flags
 - Double word flags
 - Step chains
 - Historical values
 In order to back-up certain data, they have to be excluded from initialization to 0.
- Initialization of data areas
During *program start*, that data areas are initialized to 0 partly or completely, that are defined by system con-

stants (see chapter A7.3 (Appendix), System constants).

If no battery is effective or if the system constants are in their default values (factory settings), all of the above mentioned data areas are completely set to 0 after power OFF/ON.

- Reactions on errors of error class 3
The user can configure whether or not the user program is to be aborted automatically, if a class 3 error occurs, see chapter A7.3 (Appendix), System constants.
- Starting-up the AC31-S system after power ON
The user must enter a number of n remote modules in KW 00,09. The user program starts only, i.e. it handles process inputs and outputs only, if at least n remote modules have been adopted into the CS31 system bus cycle, see chapter A7.3 (Appendix), System constants.

3.2 Overall view

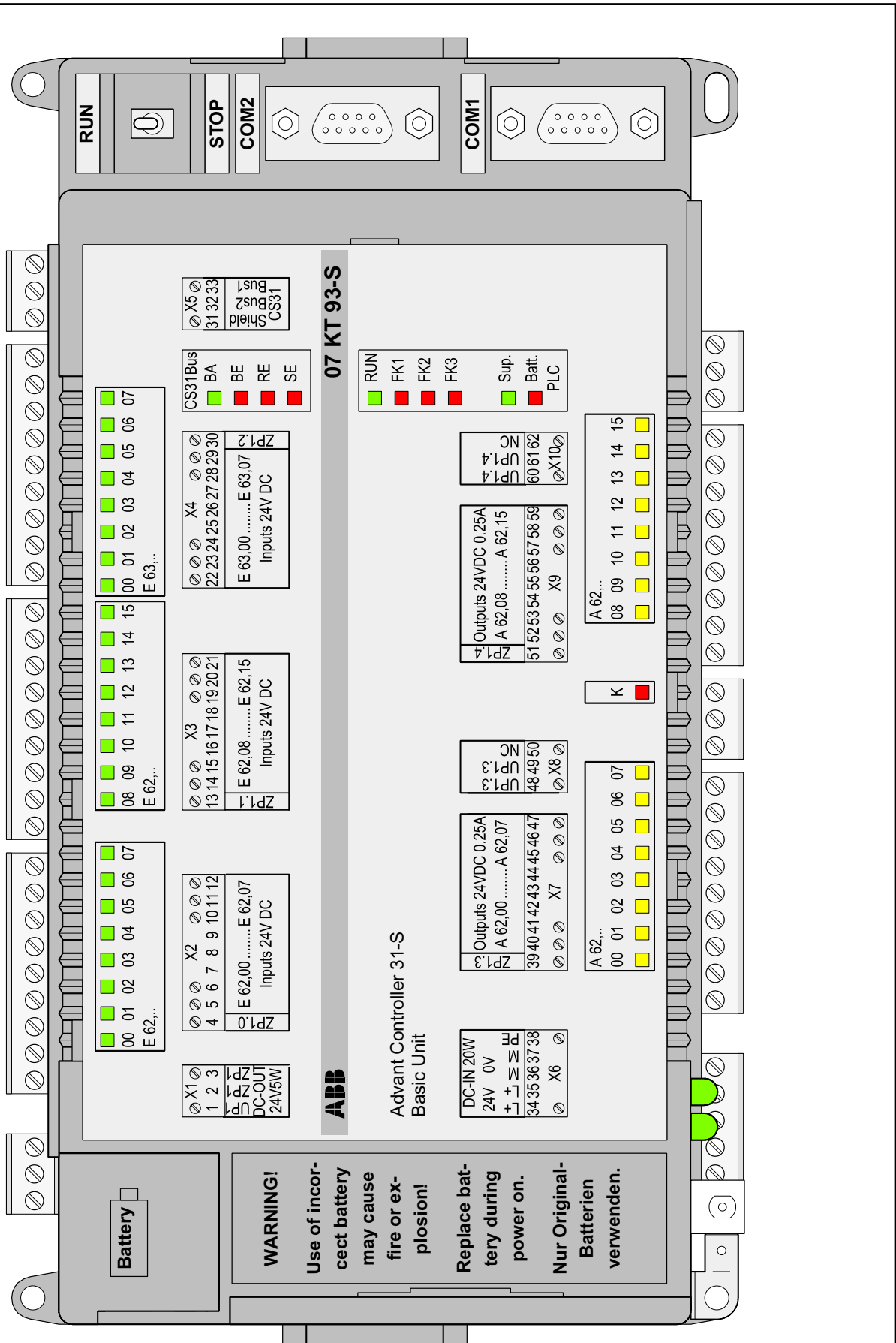

Figure 3-2: 07 KT 93-S, overall view

3.3 Structure of the front panel

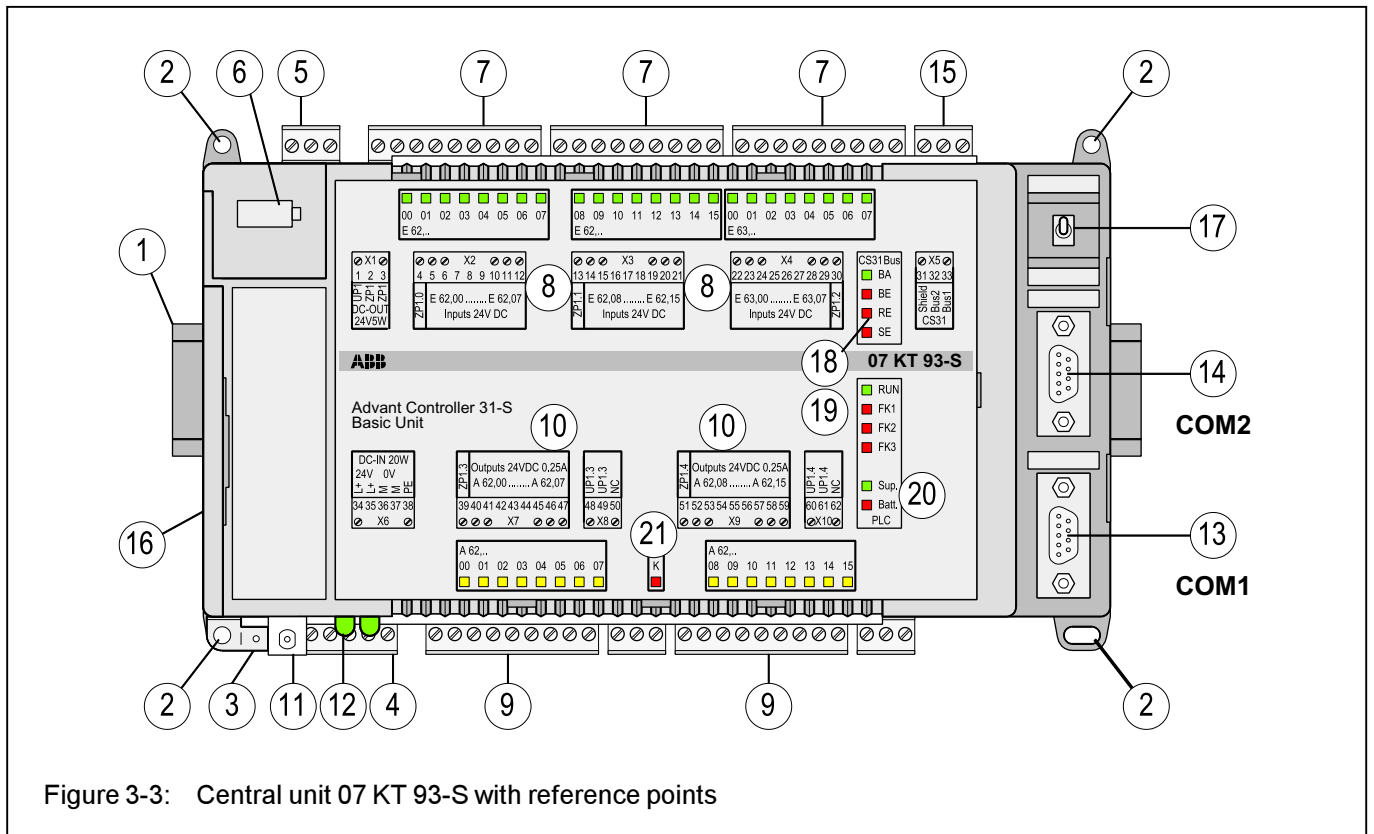
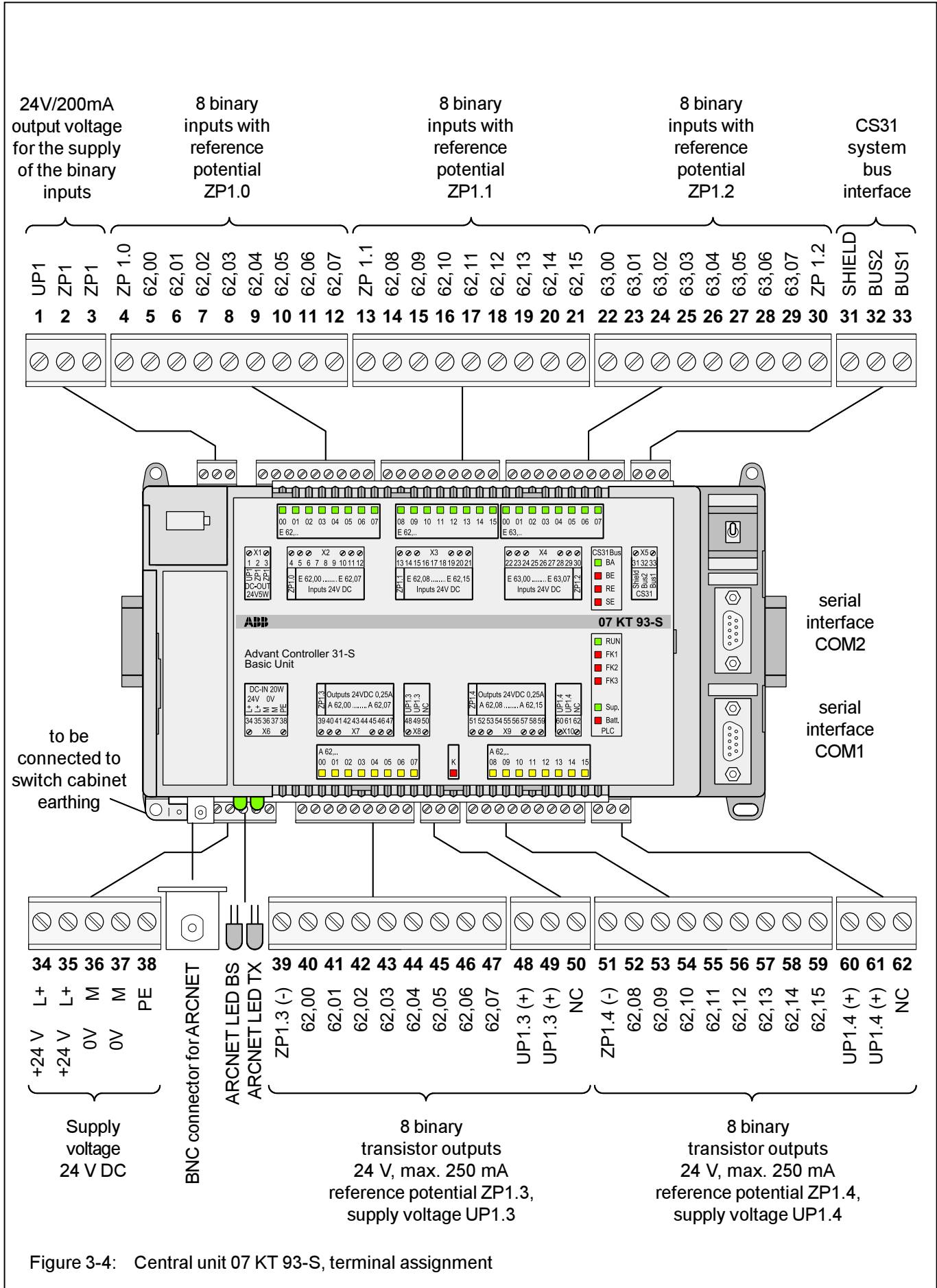

Figure 3-3: Central unit 07 KT 93-S with reference points

- | | | | | | | | | | | | | | | | | | | | | | | | | | | | | | | | | | | |
|--|---|--|-----------|------------|----|---------|-----------|----|---------|-------------------|----|---------|-------------------|-----|-----------|----------------------|-----|---------|-------------|-----|---------|---------------|-----|---------|-------------|--------|-----------|--------------------------|---------|---------|------------------------------|---|---------|--|
| <ul style="list-style-type: none"> ① Fastening of the device on DIN rail ② Fastening of the device by screws ③ Faston earthing terminal 6.3 mm ④ Supply voltage connection 24 V DC ⑤ 24 V output voltage for input supply ⑥ Battery compartment ⑦ 24 binary inputs in three groups ⑧ Assignment of the identifiers for the inputs ⑨ 16 binary transistor outputs in two groups ⑩ Assignment of the identifiers for the outputs ⑪ ARCNET BNC connector ⑫ 2 LEDs for ARCNET operation ⑬ Serial interface COM1 (programming, MMC) ⑭ Serial interface COM2 (MMC) ⑮ Connection for CS31 system bus | <ul style="list-style-type: none"> ⑯ Cover of the interface for the connection of communication modules (may only be removed for connecting communication modules) ⑰ Switch for RUN/STOP operation:
The RUN/STOP switch is used to start or abort the processing of the user program ⑱ LEDs for CS31 system bus <table border="0" style="margin-left: 20px;"> <tr><td>BA</td><td>LED green</td><td>Bus active</td></tr> <tr><td>BE</td><td>LED red</td><td>Bus error</td></tr> <tr><td>RE</td><td>LED red</td><td>Remote unit error</td></tr> <tr><td>SE</td><td>LED red</td><td>Serial unit error</td></tr> </table> ⑲ LEDs for RUN and error class <table border="0" style="margin-left: 20px;"> <tr><td>RUN</td><td>LED green</td><td>User program running</td></tr> <tr><td>FK1</td><td>LED red</td><td>Fatal error</td></tr> <tr><td>FK2</td><td>LED red</td><td>Serious error</td></tr> <tr><td>FK3</td><td>LED red</td><td>Light error</td></tr> </table> ⑳ Other LED displays <table border="0" style="margin-left: 20px;"> <tr><td>Supply</td><td>LED green</td><td>Supply voltage available</td></tr> <tr><td>Battery</td><td>LED red</td><td>Battery not effective</td></tr> </table> ㉑ LED for short-circuit <table border="0" style="margin-left: 20px;"> <tr><td>K</td><td>LED red</td><td>Short-circuit or overload on one transistor output</td></tr> </table> | BA | LED green | Bus active | BE | LED red | Bus error | RE | LED red | Remote unit error | SE | LED red | Serial unit error | RUN | LED green | User program running | FK1 | LED red | Fatal error | FK2 | LED red | Serious error | FK3 | LED red | Light error | Supply | LED green | Supply voltage available | Battery | LED red | Battery not effective | K | LED red | Short-circuit or overload on one transistor output |
| BA | LED green | Bus active | | | | | | | | | | | | | | | | | | | | | | | | | | | | | | | | |
| BE | LED red | Bus error | | | | | | | | | | | | | | | | | | | | | | | | | | | | | | | | |
| RE | LED red | Remote unit error | | | | | | | | | | | | | | | | | | | | | | | | | | | | | | | | |
| SE | LED red | Serial unit error | | | | | | | | | | | | | | | | | | | | | | | | | | | | | | | | |
| RUN | LED green | User program running | | | | | | | | | | | | | | | | | | | | | | | | | | | | | | | | |
| FK1 | LED red | Fatal error | | | | | | | | | | | | | | | | | | | | | | | | | | | | | | | | |
| FK2 | LED red | Serious error | | | | | | | | | | | | | | | | | | | | | | | | | | | | | | | | |
| FK3 | LED red | Light error | | | | | | | | | | | | | | | | | | | | | | | | | | | | | | | | |
| Supply | LED green | Supply voltage available | | | | | | | | | | | | | | | | | | | | | | | | | | | | | | | | |
| Battery | LED red | Battery not effective | | | | | | | | | | | | | | | | | | | | | | | | | | | | | | | | |
| K | LED red | Short-circuit or overload on one transistor output | | | | | | | | | | | | | | | | | | | | | | | | | | | | | | | | |

3.3.1 Terminal assignment overview



3.4 Electrical connection

3.4.1 Application example for input and output wiring

The following figure shows an application example in which different possibilities for wiring inputs and outputs are used.

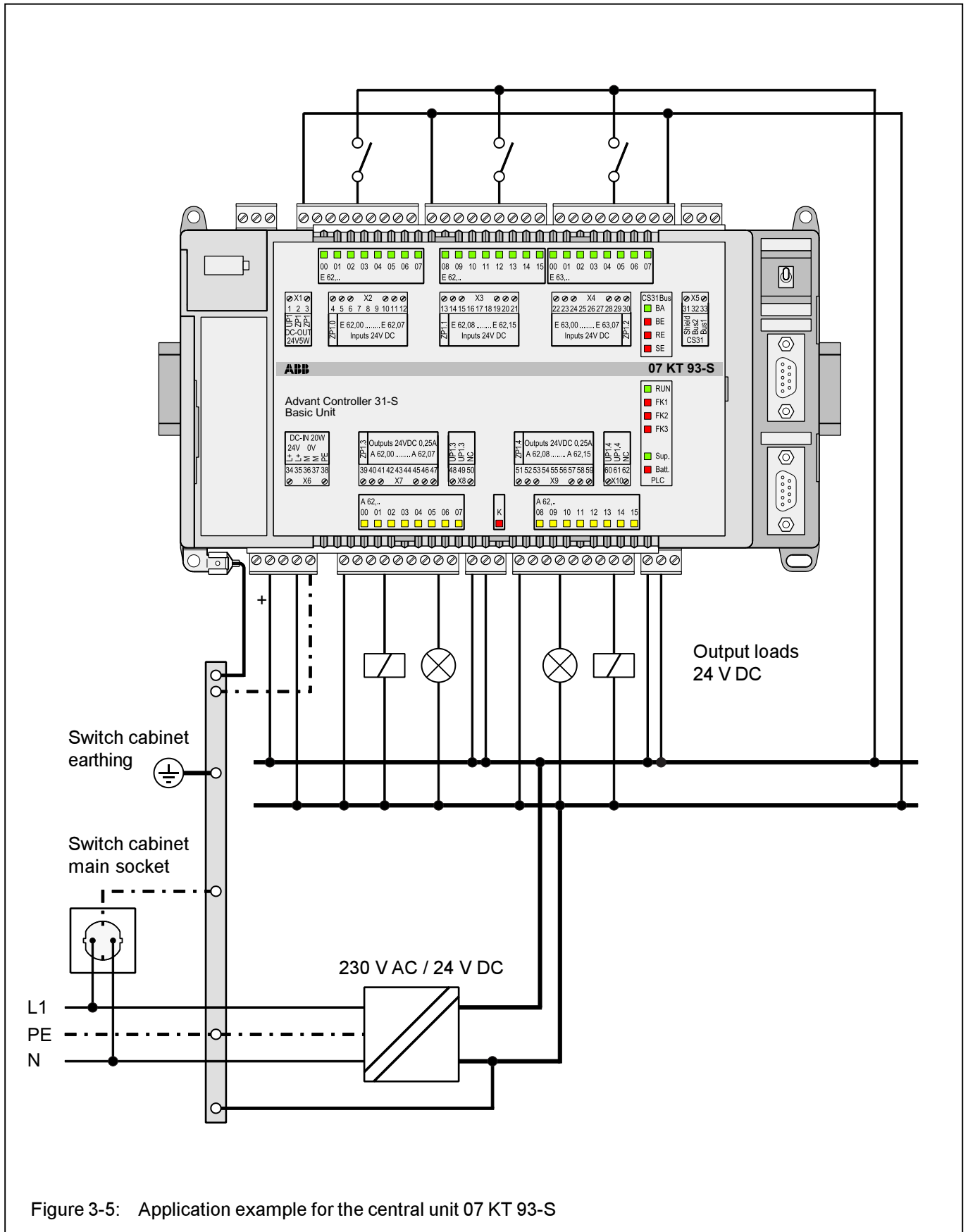

Figure 3-5: Application example for the central unit 07 KT 93-S

Please observe in particular:

- The earthing measures.
- The handling of the electrically isolated input groups.
- The handling of the electrically isolated output groups.
- The earthing of the switch cabinet mains socket.

3.4.2 Connecting the supply voltage

The 24 V DC supply voltage is connected via a 5-pole detachable terminal block.

Attention: Plug and unplug the terminal block only when power is off!

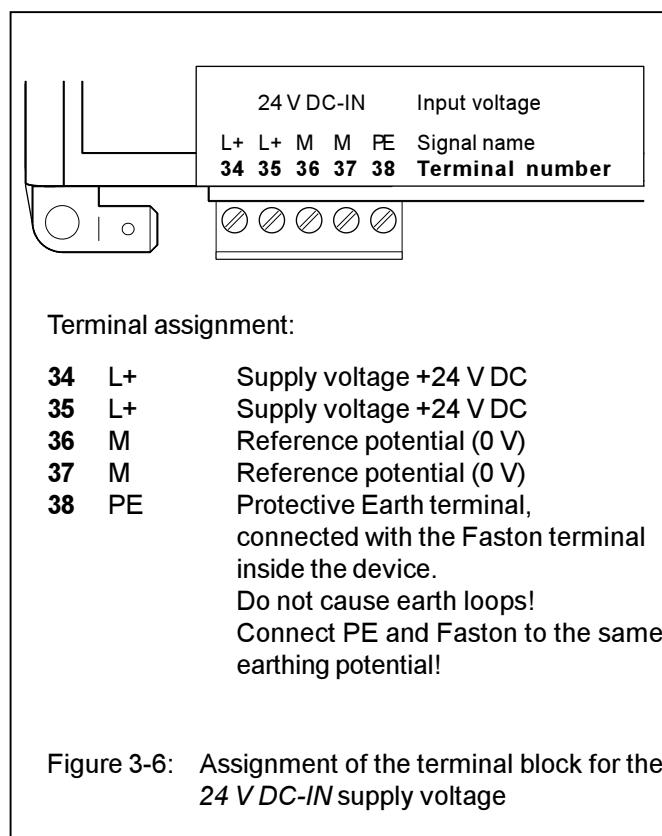

3.4.3 Electrical isolation and notes on earthing

The following figure shows the parts of the device's circuit which are electrically isolated from each other as well as the existing internal connections. Both the creepage distances and clearances as well as the test voltages used correspond to DIN/VDE 0160.

The 6.3 mm Faston terminal in the lower left corner has to be connected directly and on the shortest possible way to the switch cabinet earthing using a wire with a cross section of 6 mm² in order to ensure safe earthing and as an EMC measure.

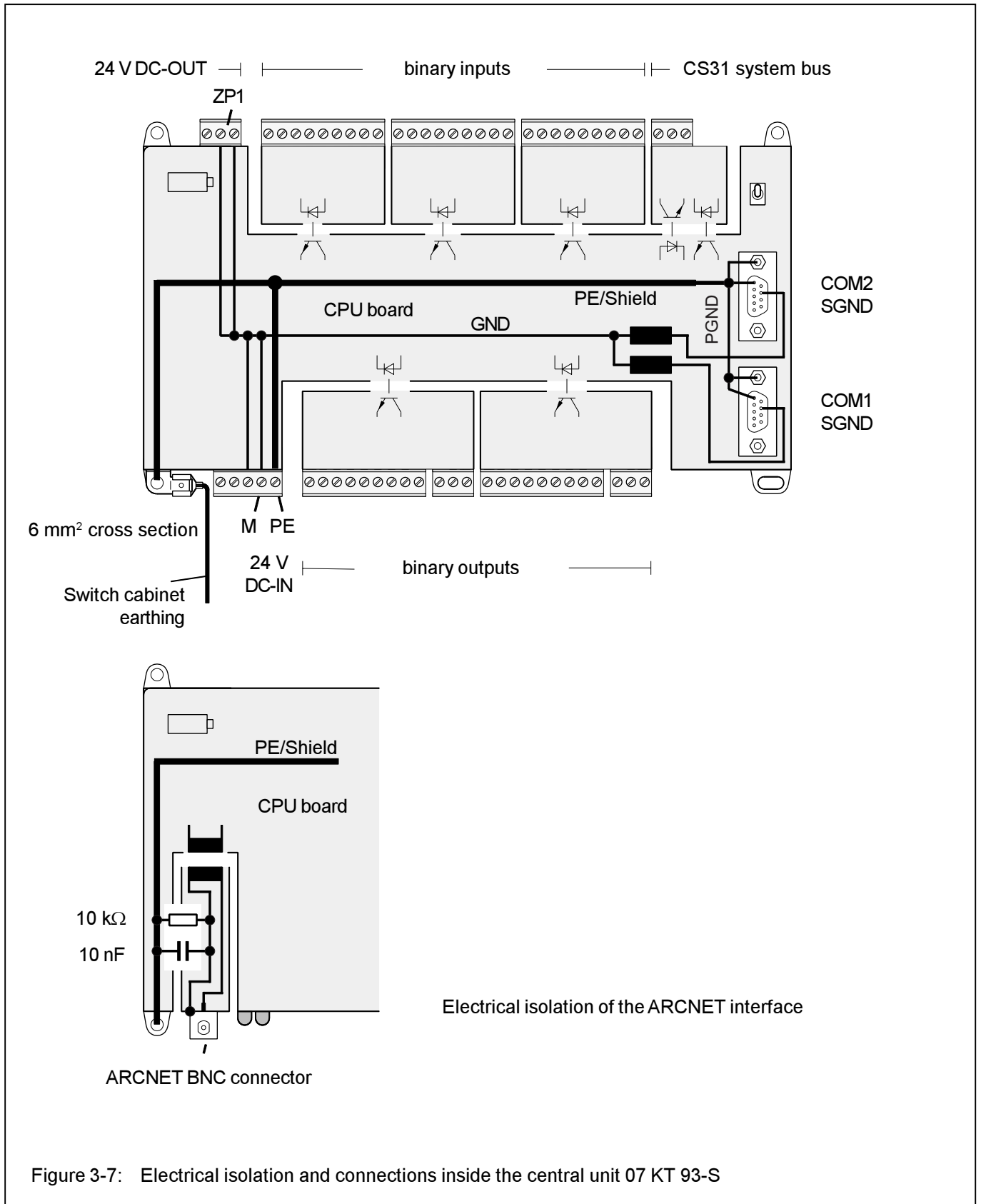

Figure 3-7: Electrical isolation and connections inside the central unit 07 KT 93-S

3.4.4 ARCNET interface

see also chapter A8 (Appendix)

- It is not permitted to transfer safety-related data via the ARCNET bus.
- The ARCNET coupler is integrated in the central unit 07 KT 93-S. The DIL switch for setting the ARCNET address is accessible through the cutout of the external networking interface.
- The ARCNET coupler is supplied from the internal 24 V DC power supply.
- The function blocks AINIT, ASEND, AREC and APOLL are available for the ARCNET coupling.
- The data packages are read from the ARCNET controller interrupt-controlled. The interrupt routine stores the data package in the storage buffer. The APOLL block serves for the sending direction. It transfers data packages from the storage buffer to the ARCNET controller for sending them off.
- The ARCNET coupler interface is designed as a bus with BNC connector for coaxial cable. The ARCNET bus is earthed inside the module via a capacitor. As an EMC measure and for protection against dangerous contact voltages, the bus has to be earthed directly at a central place.
- Using the simplest configuration, called Linear ARCNET, a coaxial cable (RG62, 93 Ω) is laid from station to station and connected with T plugs at all stations. At both ends of the cable, termination resistors with 93 Ω each have to be installed, for more information see chapter A8.1 (Appendix). In a Linear ARCNET, a maximum of 8 stations is possible at a cable length of 300 m.
- The parallel networking interface is used for the ARCNET coupler inside the module. However, it is still available from outside as an external networking interface. The serial interface module 07 KP 92 can be connected here, for instance.

Setting the ARCNET node number (station address) of the central unit:

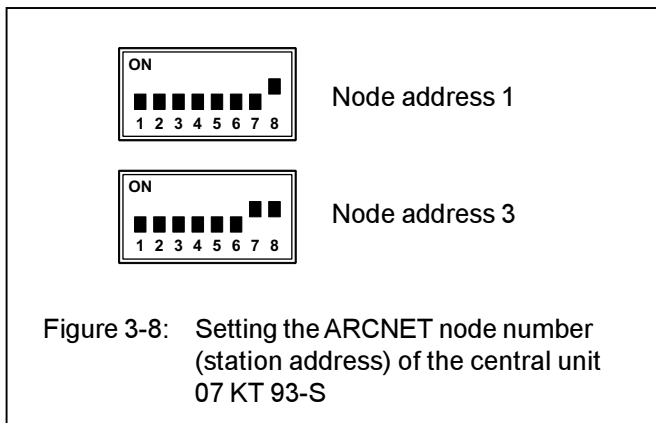

3.4.5 Connection for CS31 system bus

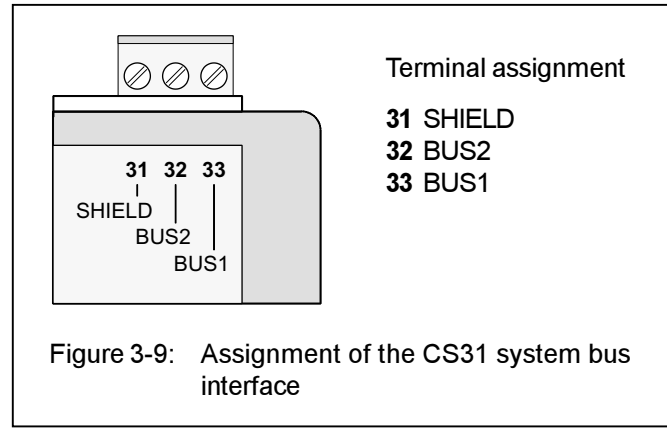

The connection to the CS31 system bus is made by means of a 3-pole detachable terminal block. Please observe:

- All of the AC31 devices, no matter whether they are master or slave devices, are connected with the twisted-pair bus line as follows:
 - One core of the bus line is looped through via the BUS1 terminals of all devices to be connected to the CS31 system bus.
 - The other core of the bus line is looped through via the BUS2 terminals of all devices to be connected to the CS31 system bus.
- If the central unit 07 KT 93-S is located at the beginning or at the end of the bus line, the bus terminating resistor (120 Ω) has to be connected additionally between the BUS1 and BUS2 terminals.
- The shield of the twisted-pair bus line is looped through via the SHIELD terminals of all the devices to be connected to the CS31 system bus.
- The handling of the CS31 system bus is described in detail in volume 2, System data.

3.4.6 24 V output voltage for the signal supply of the inputs

An internal 24 V power supply is available for the supply of the 24 binary signal inputs (only for this purpose).

This 24 V output voltage is used only if an external 24 V DC power supply unit is not available.

The internal 24 V power supply is overload-proof. The 24 V output voltage is ready for operation again approx. 2 minutes after an overload has been eliminated.

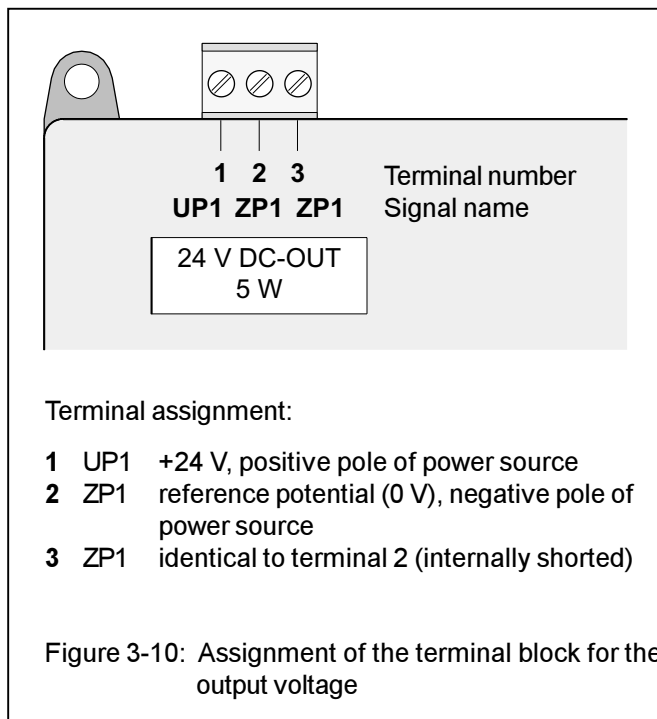

3.4.7 Connection of the binary inputs

The binary inputs may not be used for safety-related signals.

The following figure shows the circuit configuration of the binary inputs of the first group as an example.

Features:

- The 24 binary inputs are arranged in three groups.
- The three groups E 62,00...E 62,07, E 62,08...E 62,15 and E 63,00...E 63,07 are electrical-ly isolated from each other (see Fig. 3-5).
- The inputs use 24 V signals in positive logic (1 corresponds to + 24 V).

Input signals at the terminals 5 and 6

Terminal 5

- Use as normal input signal:

The signal is available in the user program in the operand E 62,00. The signal delay time is 2.5 ms.

The updating of the operand E 62,00 is performed before the start of each program cycle.

- Use as high-speed input signal:

The signal is available in the user program in the operand E 63,14. The signal delay time is 0.02 ms.

The updating of the operand E 63,14 is performed before the start of each program cycle.

In the Dual Port RAM (DPR) this signal is updated after each CS31 bus telegram. With the aid of the function block WOL this signal can be read in the Dual Port RAM (word address C000:1FEH, Bit 14).

- Use for the high-speed counter:

The signal is used as counting input (10 kHz) for the high-speed counter.

Terminal 6

- Use as normal input signal:

The signal is available in the user program in the operand E 62,01. The signal delay time is 2.5 ms.

The updating of the operand E 62,01 is performed before the start of each program cycle.

- Use as high-speed input signal:

The signal is available in the user program in the operand E 63,15. The signal delay time is 0.02 ms.

The updating of the operand E 63,15 is performed before the start of each program cycle.

In the Dual Port RAM (DPR) this signal is updated after each CS31 bus telegram. With the aid of the function block WOL this signal can be read in the Dual Port RAM (word address C000:1FEH, Bit 15).

- Use for the high-speed counter:

The signal is used as enable input (counter release) for the high-speed counter.

Circuit configuration of the binary inputs of the first group as an example (E62,00...E 62,07)

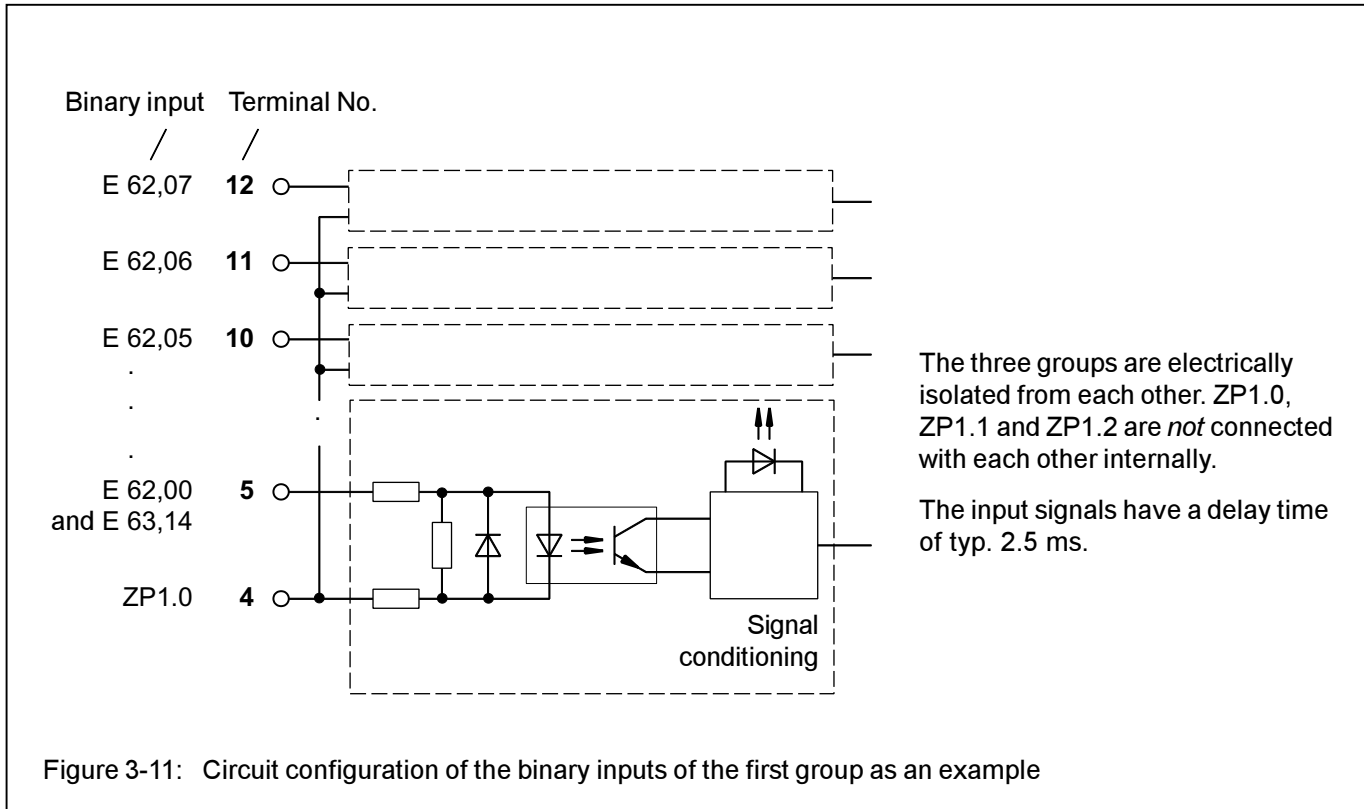

3.4.8 Connection of the binary outputs

The binary outputs may not be used for safety-related signals.

The following figure shows the circuit configuration of the binary outputs.

Features of the outputs:

- The 16 outputs are arranged in two groups. Within one group, the outputs are not electrically isolated from each other.
- The outputs can be loaded with a rated current of 250 mA.
- Each group as a whole is electrically isolated from the rest of the device (see also Fig. 3-5).
- The outputs use transistors and are short-circuit-proof.
- The eight transistors of one group have a common power supply.
- The outputs are automatically switched off in case of overload or short-circuit.
- An overall error message indicates a short-circuit or an overload which has occurred on one or on several outputs.
- An overload is displayed by the red LED K and via error flags in the PLC.
- The user can set by means of a system constant whether the overloaded output is to be switched on again automatically by the PLC or whether it is to be switched on again by configuring within the PLC program, e.g. by means of the function blocks CS31QU or CS31CO. The default setting is the automatic reclosure of the outputs.
- The red LED K goes out when the overloaded output is switched on again after eliminating the overload.
- The acknowledgement of the error message, i.e. the resetting of the error flags, is done in correspondence with chapter A4.8 (Appendix), Acknowledgement of error messages in the central unit.

Circuit configuration of the binary outputs of the first group as an example (A 62,00...A 62,07)

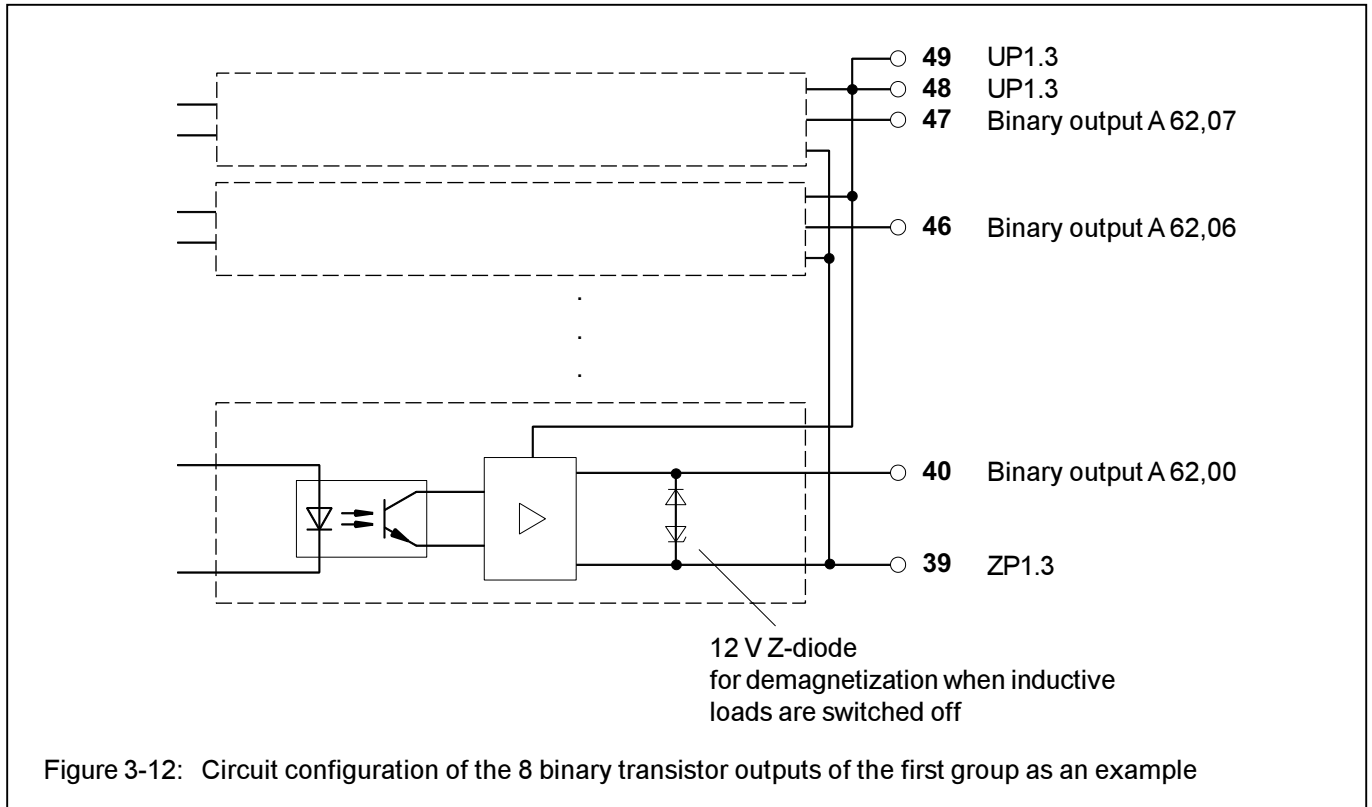

3.4.9 Battery and battery replacement

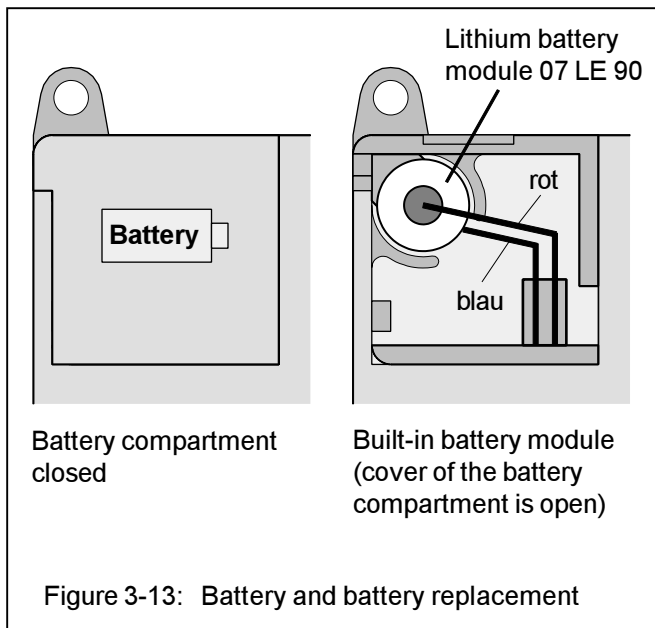

- The lithium battery 07 LE 90 can be inserted into the battery compartment in order to
 - backup data of user program in RAM
 - backup data of additionally in RAM contained information, e.g. flag status
 - backup of time and date (real-time clock).

The battery lifetime is 1.5 years (typ. 3 years) at 25°C. The battery lifetime is the time during which the device remains operable in order to backup data while the supply voltage of the central unit is switched off. As long as there is a supply voltage available, there is no more load on the battery other than its own leakage current.

The following handling notes have to be observed:

- Use only lithium batteries approved by ABB.
- Replace the battery by a new one at the end of its lifetime.
- **Never short-circuit the battery!** There is danger of overheating and explosion. Avoid accidental short-circuits, therefore do not store batteries in metallic containers or boxes and do not bring it into contact with metallic surfaces.
- **Never try to charge the battery!** Danger of overheating and explosion!
- **Replace the battery only with the supply voltage switched on.** Otherwise you risk data being lost.
- **Dispose of battery environmentally consciously!**
- If no battery is built-in or if the battery is exhausted, the red LED "Battery" lights up.

3.4.10 Serial interface COM 1

Interface standard: EIA-232

Assignment of the serial interface COM1

The serial interface COM 1 has the following pin assignment:

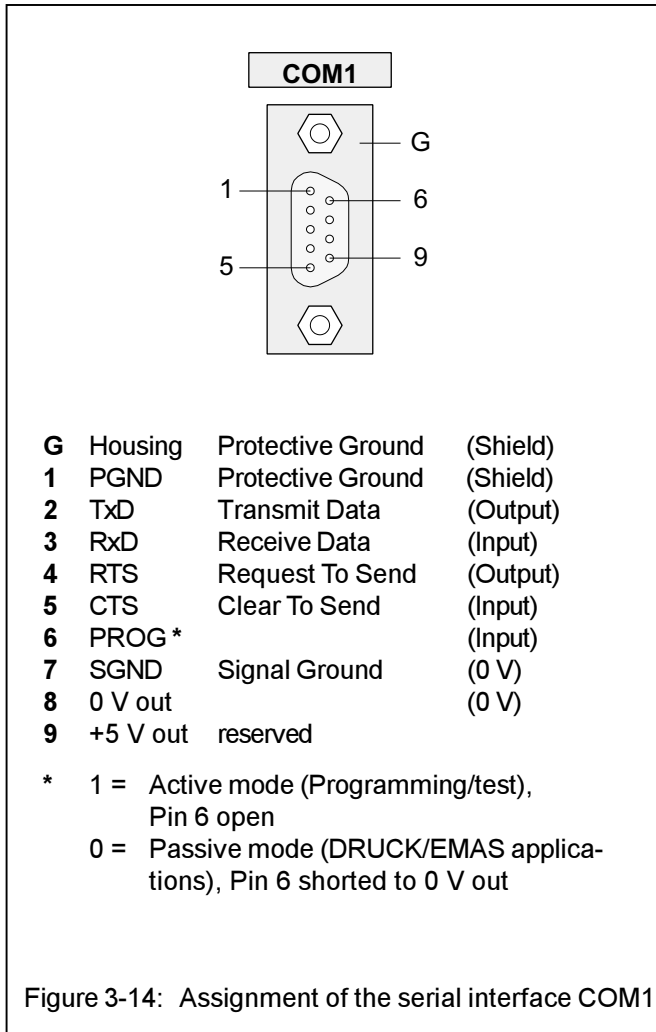

Figure 3-14: Assignment of the serial interface COM1

Operating modes of the serial interface COM1

The operating mode of the interface has to be set according to the application in each case

- Programming and test or
- Man-machine-communication MMC

Active mode: The active mode is used for programming and testing the central unit, i.e. it gives the user access to all the programming and test functions of the central unit.

Passive mode: The passive mode is used to perform a communication configured with the DRUCK and EMAS blocks between the user program and a device connected to the serial interface.

Conditions for setting the operating modes of the interface COM1

RUN/STOP switch	System constant KW00,06	System cable/device	Mode set by this
STOP	x	x	Active
RUN	1	x	Active
	2	x	Passive
	0, <0, >2	07 SK 90	Active
07 SK 91		Passive	

x: without effect

Temporary interruption of the passive mode

While a communication between the DRUCK or EMAS blocks and a device connected to COM1 is being executed, it may become necessary to modify the program, for example. For this purpose, you must switch over COM1 from the passive mode into the active mode.

Switch-over: Passive mode -> Active mode

There are three possibilities for switching over:

- Set the RUN/STOP switch to the "STOP" position
- Replace cable 07 SK 91 by cable 07 SK 90 (if KW 00,06 is set to ≤ 0 or > 2)
- Send the following special command to the PLC:
``

The latter option has the advantage that the switch-over can also be controlled remotely, e.g. via telephone line and suitable dial-up modems. The ASCII character has the decimal code of 127 and the hexadecimal code of 7F_H. You can generate this character on your PC by simultaneously pressing the control key <CTRL> and the delete key <->.

Notes:

On German keyboards, the control key is labelled by <Strg> instead of <CTRL>.

If the switch-over to the active mode was performed using the special command , please observe the following:

The system constant KW 00,06 must not be sent to the PLC *during the execution* of the PLC program, because this would cause the system to be switched back to the passive mode.

The special command assigns the value of "1" to the image of the system constant KW 00,06 located in the operand memory. The PLC evaluates the value of this image and sets the kind of application of COM1 correspondingly.

Switching back: Active mode -> Passive mode

There are three possibilities for switching back:

- Return RUN/STOP switch to the "RUN" position
- Replace cable 07 SK 90 by cable 07 SK 91 again
- Cancel the special command as follows:

- If the PLC program is in the "aborted" condition:

Start the PLC program

- If the PLC program is in the "running" condition:

send the original value of the system constant KW 00,06 to the PLC again (907 PC 33 menu item "Send constants")

or

overwrite the system constant KW 00,06 by the original value (907 PC 33 menu item "overwriting")

Interface parameters

Active mode: The settings of the interface parameters cannot be changed.

Data bits: 8
Stop bits: 1
Parity bits: none
Baud rate: 9600
Synchronization: RTS/CTS

Passive mode: Default setting

Synchronization: RTS/CTS
Interface identifier COM1: 1
Baud rate: 9600
Stop bits: 1
Data bits: 8
Parity bits: none
Echo: off
Send Break Character: 0
Enabling End-of-text character for sending direction: no ¹⁾
Sending End-of-text character: <CR> ¹⁾
Receiving End-of-text character: <CR> ²⁾

1) The default End-of-text character for the sending direction (CR) is not sent. Nevertheless, this default End-of-text character (CR) must not appear in the message text of the assigned DRUCK block.

2) For the direction of reception, an End-of-text character is always necessary. This default End-of-text character (CR) must not appear neither in the message text nor in the user data of the assigned EMAS block.

For the passive mode of COM1, the interface parameters can be changed using the SINIT function block. If the changed values are not plausible, the COM1 interface uses the default values.

The interface is newly initialized each time the operating mode is switched over.

The active-mode parameters are set in the active mode, whereas in the passive mode the parameters established by the SINIT block or the default values are set.

3.4.11 Serial interface COM 2

Interface standard: EIA-232

Assignment of the serial interface COM2

The serial interface has the following pin assignment:

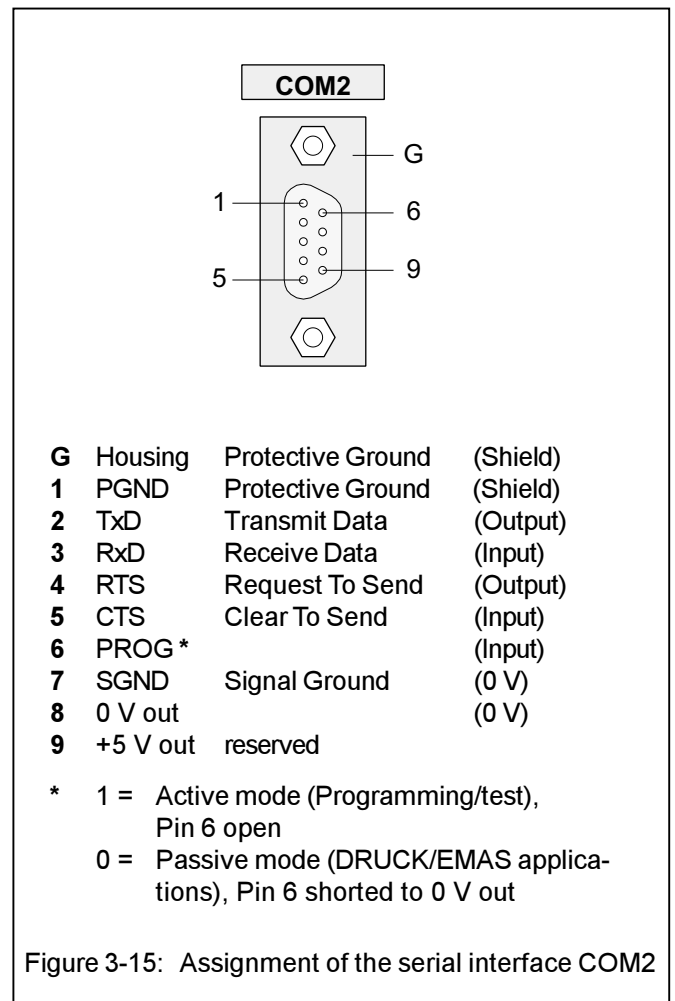

Figure 3-15: Assignment of the serial interface COM2

Operating modes of the COM2 interface

The serial interface COM2 is fixedly set to the **passive mode** (MMC interface).

The passive mode is used to perform a communication configured with the aid of the DRUCK and EMAS blocks between the user program and a device connected to the serial interface.

The application-specific initialization of COM2 can be performed using the SINIT function block.

Interface parameters

Passive mode: Default setting

Synchronization:	RTS/CTS
Interface identifier COM2:	2
Baud rate:	9600
Stop bits:	1
Data bits:	8
Parity bits:	none
Echo:	off
Send Break Character:	0
Enabling End-of-text character :	no ¹⁾
Sending End-of-text character:	<CR> ¹⁾
Receiving End-of-text character:	<CR> ²⁾

¹⁾ The default End-of-text character for the sending direction (CR) is not sent. Nevertheless, this default End-of-text character (CR) must not appear in the message text of the assigned DRUCK block.

²⁾ For the direction of reception, an End-of-text character is always necessary. This default End-of-text character (CR) must not appear neither in the message text nor in the user data of the assigned EMAS block.

For the passive mode of COM2, the interface parameters can be changed using the SINIT function block. If the changed values are not plausible, the COM2 interface uses the default values.

In the passive mode the parameters established by the SINIT block or the default values are set.

3.4.12 Networking interface

The 07 KT 93-S central unit is equipped with a special parallel interface. It is thus possible to network it with another bus system using an additional communication processor module. The additional communication processor has its own housing. Both housings (of the 07 KT 93-S and of the communication processor) are assembled by means of a snap-on connection.

Safety-related data may not be sent or received via the networking interface.

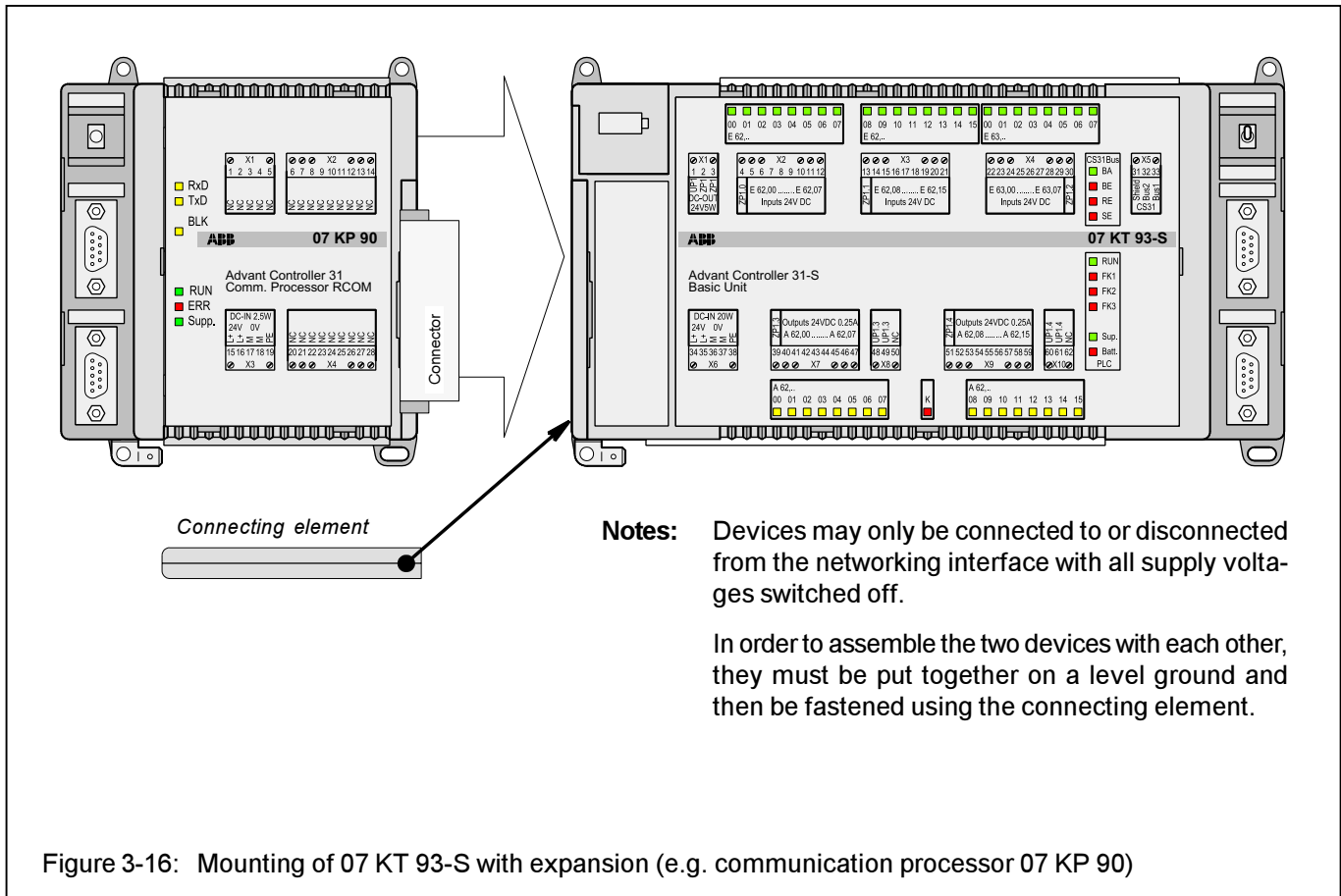

Figure 3-16: Mounting of 07 KT 93-S with expansion (e.g. communication processor 07 KP 90)

3.5 High-speed counter

Features

The high-speed counter function may not be used for safety-related applications.

The high-speed counter of the central unit 07 KT 93-S works independently of the user program and is therefore able to response quickly to external signals. Its features are as follows:

- The counting frequency is max. 10 kHz. The counter counts the 0 → 1 edges at terminal 05 (also designated as E 62,00).
- The counter counts upwards from -32768 to +32767 (8000_H...7FFF_H). If +32767 is exceeded, the counter skips to -32768.

Sequence of the counting procedure:

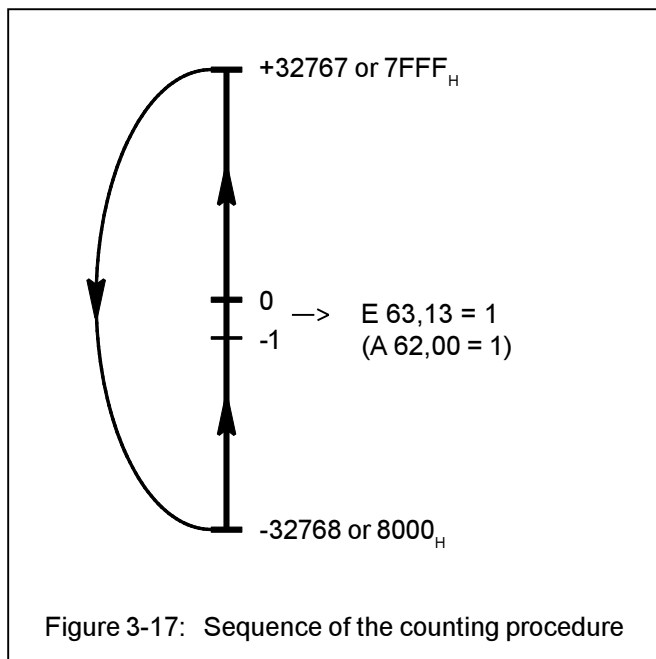

- Enabling/disabling of the counting procedure using the internal variable A 63,14 in the user program:
 - A 63,14 = 0:
The internal variable A 63,13 = 1 enables the counting procedure, whereas A 63,13 = 0 disables it.
 - A 63,14 = 1:
Signal 1 at terminal 06 (also designated as E 62,01) enables the counting procedure, whereas signal 0 disables it. A 63,13 is without effect.
Note: The dead time may be 0...1.5 ms.

- Setting the counter in the user program:
 - to the value contained in the internal word variable AW 06,15
 - using the internal variable A 63,15 = 1.

Note: If the internal variable A 63,15 = 1 is present during several processing cycles, the processor sets the counter at the program end in each case. During the remaining time of the processing cycle, the counter counts pulses at terminal 05.

- The counter content can be read via the internal variable EW 06,15.
- Zero-crossing message (signal changes from 0 to 1 when the counter contents changes from -1 to 0):
 - always via the internal variable E 63,13,
 - at the terminal 40 (also designated as A 62,00) only, if the internal variable A 63,14 = 1 is set.
Note: The reaction time may be 0...1.5 ms. The direct control of the output A 62,00 from the user program is disabled by A 63,14 = 1.

The zero-crossing message is cancelled when the counter is set.

- Fast input of binary signals into the user program with a delay of < 0.02 ms:
 - Terminal 05 (also designated as E 62,00):
Internal variable E 63,14
 - Terminal 06 (also designated as E 62,01):
Internal variable E 63,15

Block diagram

see next page

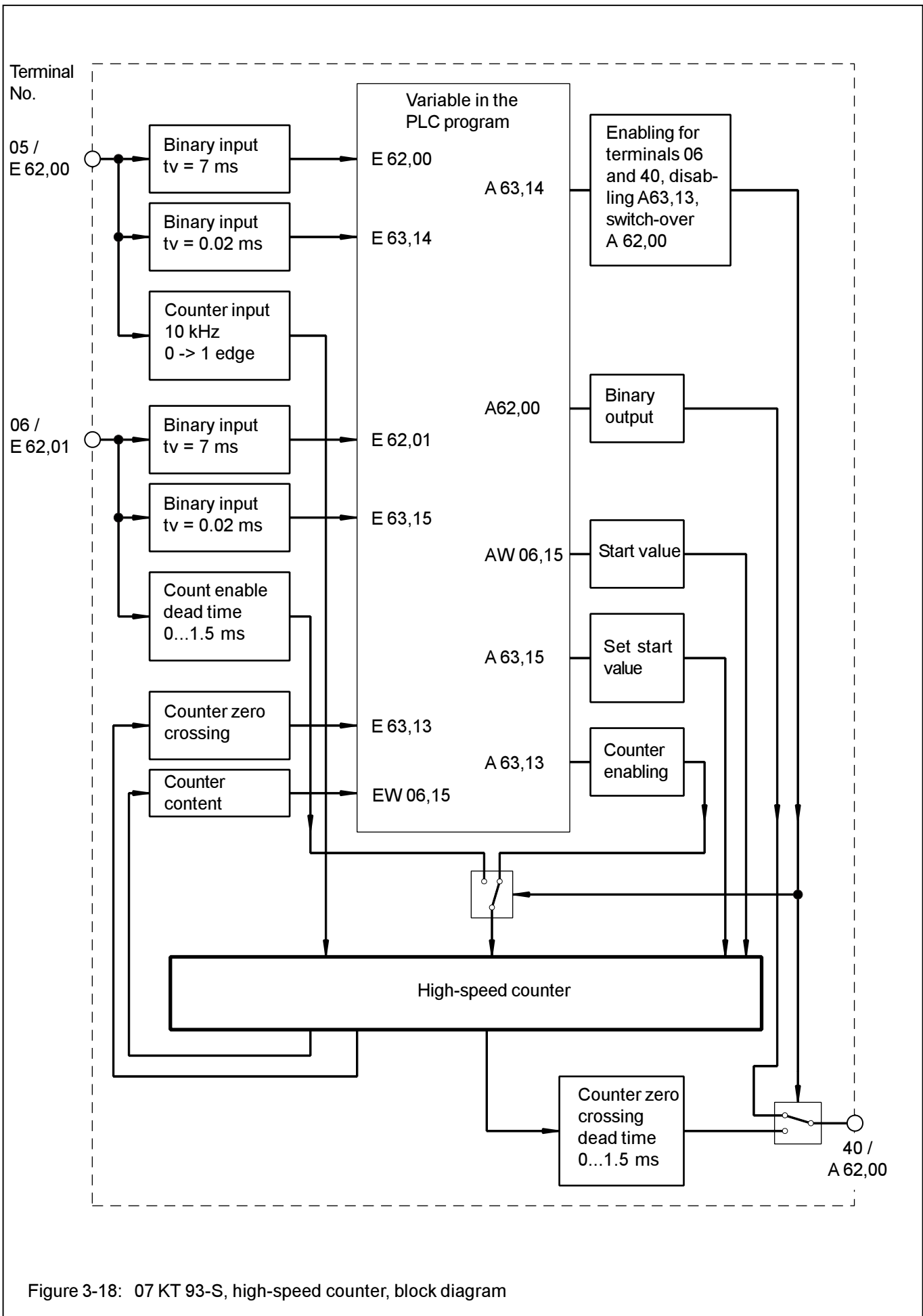

Figure 3-18: 07 KT 93-S, high-speed counter, block diagram

Configuration example

• Task

- 180 pieces each of an unit load have to be filled into a packing.
- Each filled-in piece generates one pulse.
- When the packing is full, the counter is immediately prepared for the next filling operation.
- The enabling signal for the filling operation is sent by the packaging machine.
- The end of the counting operation has to be signalled to the packaging machine immediately.

• Wiring

- Connect the signal line for the counting pulses to terminal 05.
- Connect the signal line for the enabling of the counting operation to terminal 06.
- Connect the signal line for "zero crossing" of the counter to terminal 40.

• Configuration steps: PLC program

1) Activate terminals 06 and 40

- The terminals 06 and 40 are activated using the operand A 63,14.

IL (instruction list):

```
! K 00,01  
= A 63,14 (with K 00,01 = 1)
```

2) Preset start value for the counter

The start value (AW 06,15) is set to the value of -180. The counter will then count starting from -180 in positive direction. The transition from -1 to 0 will be signalled.

IL (instruction list):

```
! KW 01,00  
= AW 06,15 (with KW 01,00 = -180)
```

3) Adopt start value into the counter

After each counting operation, the start value is immediately set again into the counter by means of the "zero crossing" signal (E 63,13). Operand A 63,15 = 1 has to be set for this purpose. At program start, the start value is loaded once into the counter by means of the initialization flag M 255,15 (M 255,15 has the value of 0 after program start).

IL (instruction list):

```
! NM 255,15  
/ E 63,13  
= A 63,15  
:  
:  
other PLC program parts  
:  
:  
! K 00,01  
= M 255,15 (set M 255,15 = 1)  
! PE (program end)
```

Preset start values

You can preset both positive and negative start values for the counter.

The counting operation starts at the start value and is continued in correspondence with the arrows in the diagram until the enabling is stopped or a start value is loaded again.

Negative start value

The minimum negative start value is -32768 (8000_{16}). By presetting a negative start value it is thus possible to count a maximum of 32768 pulses up to the zero crossing of the counter.

Positive start value

If a positive start value is preset, the counter counts up to the value of +32767 ($7FFF_{16}$), continues the counting operation at the value of -32768 (8000_{16}) and then signals the zero crossing when reaching the transition from -1 to 0.

The minimum positive start value is 1. If you preset this value, 65535 pulses will be counted up to the zero crossing.

In order to count more than 32768 pulses up to the zero crossing, the start value has to be calculated according to the following equation:

$$\text{Start value} = 32767 - (\text{number of pulses} - 32768)$$

Example:

40 000 pulses are to be counted.

The start value is in the positive range, because more than 32768 pulses have to be counted.

Calculation:

$$\begin{aligned}\text{Start value} &= 32767 - (\text{number of pulses} - 32768) \\ &= 32767 - (40\,000 - 32768) \\ &= 25535\end{aligned}$$

3.6 Technical data 07 KT 93-S

In general, the technical system data listed in volume 2 of the system description "Advant Controller 31" are valid. Additional data or data which are different from the system data are listed as follows.

3.6.1 General data

Number of binary inputs	24
Number of binary transistor outputs	16
I/O expansion via CS31 system bus by up to	744 binary inputs 496 binary outputs 96 analog input channels 48 analog output channels max. 31 remote modules altogether
Number of serial interfaces	2 (for programming or connection to man-machine communication)
Number of parallel interfaces	1 special interface for connection of a communication processor (for networking with other bus systems)
Networking interfaces	1 ARCNET interface (BNC connector)
Integrated memory	Flash EPROM 128 kB (60 kB program data + 60 kB user data) RAM 512 kB (60 kB program data with online programming)
Resolution of the integrated real-time clock	1 second
Data of the integrated high-speed hardware counter	
counting range	0...65535 (16 bits)
counting frequency	max. 10 kHz
Processing time,	
binary operation	typ. 0.4...0.6 ms/kB program
65 % bits, 35 % words	typ. 0.7 ms/kB program
Number of software timers	any (max. 80 simultaneously active)
Delay time of the timers	5 ms...24.8 days
Number of up/down counter SW blocks	any
Number of bit flags	4096
Number of word flags	4096
Number of double word flags	512
Diagnosis	cycle time monitoring, battery monitoring, detection of syntax errors and checksum monitoring
Indication of operating status and errors	51 LEDs altogether
Conductor cross section at the detachable terminal blocks	max. 2,5 mm ²
3.6.2 Power supply	
Rated supply voltage	24 V DC
Current consumption	max. 0,25 A output current through terminal 1 (output voltage for the supply of the binary inputs)
Protection against reversed terminal connection	yes

3.6.3 24 V output voltage for the supply of inputs

Rated voltage	24 V DC
Load capability	
with rated voltage	max. 200 mA
with rated voltage = 30 V	max. 240 mA
Protection against overload	with a PTC resistor

3.6.4 Lithium battery

Battery for back-up of RAM contents	07 LE 90 battery module
Lifetime at 25°C	1.5 years (typ. 3 years)

3.6.5 Binary inputs

Number of channels per module	24
Distribution of channels into groups	3 groups of 8 channels each
Common reference potential	
for group 1 (8 channels)	ZP1.0 (channels 62,00...62,07)
for group 2 (8 channels)	ZP1.1 (channels 62,08...62,15)
for group 3 (8 channels)	ZP1.2 (channels 63,00...63,07)
Electrical isolation	between the groups, between groups and other circuitry (see also Fig. 3-7)
Signal coupling of input signals	with optocoupler
Input signal delay of	
channels E 62,00...E 63,07	typ. 7 ms
channels E 63,14 and 63,15	typ. 0.02 ms
for counter control	typ. 0.02 ms
Signalling of input signals	one green LED per channel, the LEDs correspond functionally to the input signals
Input signal voltage	
signal 0	- 30 V...+ 5 V
signal 1	+ 13 V...+ 30 V
ripple	within - 30 V...+ 5 V
when signal 0	within + 13 V...+ 30 V
when signal 1	
Input current per channel	
input voltage = + 24 V	typ. 8,0 mA
input voltage = + 5 V	≥ 0.2 mA
input voltage = + 13 V	≥ 2.0 mA
input voltage = + 30 V	≤ 10.0 mA
Max. cable length unshielded	600 m
Max. cable length shielded	1000 m

3.6.6 Binary outputs

Number of channels per module	16 transistor outputs
Distribution of channels into groups	2 groups of 8 channels each
Common reference potential	
for group 1 (8 channels)	ZP1.3 (channels 62,00...62,07),
for group 2 (8 channels)	ZP1.4 (channels 62,08...62,15)
Common supply voltage	
for group 1	UP1.3 (channels 62,00...62,07),
for group 2	UP1.4 (channels 62,08...62,15)

Electrical isolation	between the groups, between groups and other circuitry (see also Fig. 3-7)
Signalling of output signals	one yellow LED per channel, the LEDs correspond functionally to the output signals
Output current	
rated value	250 mA with UP1.3/UP1.4 = 24 V
maximum value	312 mA with UP1.3/UP1.4 = 24 V + 25 %
leakage current with signal 0	< 0,5 mA
Demagnetization of inductive loads	internally with free-wheeling diode and Z-diode (Z-diode voltage is 12 V)
Switching frequency with inductive loads	max. 0,5 Hz
Switching frequency with lamp load	max. 11 Hz with max. 5 W
Max. cable length	400 m (pay attention to voltage drop)
Short-circuit-proof/overload-proof reclosure can be performed:	yes - automatically or - by configuration
Protection against reversed connected output process supply voltage	no (destruction is possible)
Reverse feeding of signals to the outputs (forcing of signals for test purposes)	only allowed within 0V...UP, not allowed if suppl voltage UP is switched off
Total load	
via UP1.3	max. 2 A
via UP1.4	max. 2 A

3.6.7 Connection of serial interface COM1

Interface standard	EIA RS-232
Programming with 907 PC 33	by means of IBM PC (or compatible)
Electrical isolation	against binary inputs and outputs, against CS31 system bus interface (see also Fig. 3-7)
Potential differences	In order to avoid potential differences between the 07 KT 93-S central unit and the peripheral device con- nected to the COM1 interface, this device is supplied from the switch cabinet socket (see also the earthing connections in Fig. 3-5).
Pin configuration and description of the COM1 interface	see chapter 3.4.10

3.6.8 Connection of serial interface COM2

Interface standard	EIA RS-232
Electrical isolation	against binary inputs and outputs, against CS31 system bus interface (see also Fig. 3-7)
Potential differences	see COM1
Pin configuration and description of the COM2 interface	see chapter 3.4.11

3.6.9 Connection to the CS31 system bus

Interface standard	EIA RS-485
Connection as master PLC as slave PLC	yes, transmitting and receiving area are configurable yes, see chapter "System constants"
Setting of the CS31 module address	yes, by system constant, stored in the Flash EPROM of the slave PLC
Electrical isolation	against supply voltage, inputs/outputs, against COM1/COM2 interfaces (see also Fig. 3-7)
Terminal assignment and description of the CS31 bus interface	see chapter 3.4.5

3.6.10 Connection to ARCNET, see also chapter A8 (Appendix)

ARCNET interface	1 channel for connection to COAX cable
Connector X4	BNC connector
Recommended system cable	COAX cable type RG-62/U (characteristic imped. 93 Ω)
Cable length	305 m with ARCNET bus with 8 stations. Further information see SMC TECHNICAL NOTE TN7-1.
LED displays green LED (BS)	Operating mode "controller active", i.e. the PLC performs read and write operations
green LED (TX)	Operating mode "transmit active", i.e. the PLC sends data on the ARCNET bus
Electrical isolation	against supply voltage, inputs/outputs, against COM1/COM2 interfaces (see also Fig. 3-7)

3.6.11 LED displays

LEDs for indication of:

- status of binary inputs	1 green LED per channel
- status of binary outputs	1 yellow LED per channel
- power supply exists	1 green LED
- battery	1 red LED
- program runs (RUN)	1 green LED
- controller specific errors (FK1, FK2, FK3)	1 red LED per error class
- CS31 system bus runs (BA)	1 green LED
- bus specific errors (BE, RE, SE)	3 red LEDs
- overload/short-circuit of the direct binary outputs	1 red LED (K)

3.6.12 High-speed hardware counter

Data of the integrated high-speed hardware counter	
counting range	0...65535 (16 bits)
counting frequency	max. 10 kHz
used inputs	62,00 and 62,01 (the signal delay of these inputs is set to 0.02 ms for the counter)
used outputs	62,00

3.6.13 Mechanical data

Mounting on DIN rail	according to DIN EN 50022-35, 15 mm deep. The DIN rail is located in the middle between the upper and the lower edges of the module.
Fastening by screws	using 4 M4 screws
Width x height x depth	240 x 140 x 85 mm
Wiring method	removable terminal blocks with screw-type terminals, conductor cross section max. 2.5 mm ²
Weight	1.6 kg
Dimensions for mounting	see the following figure

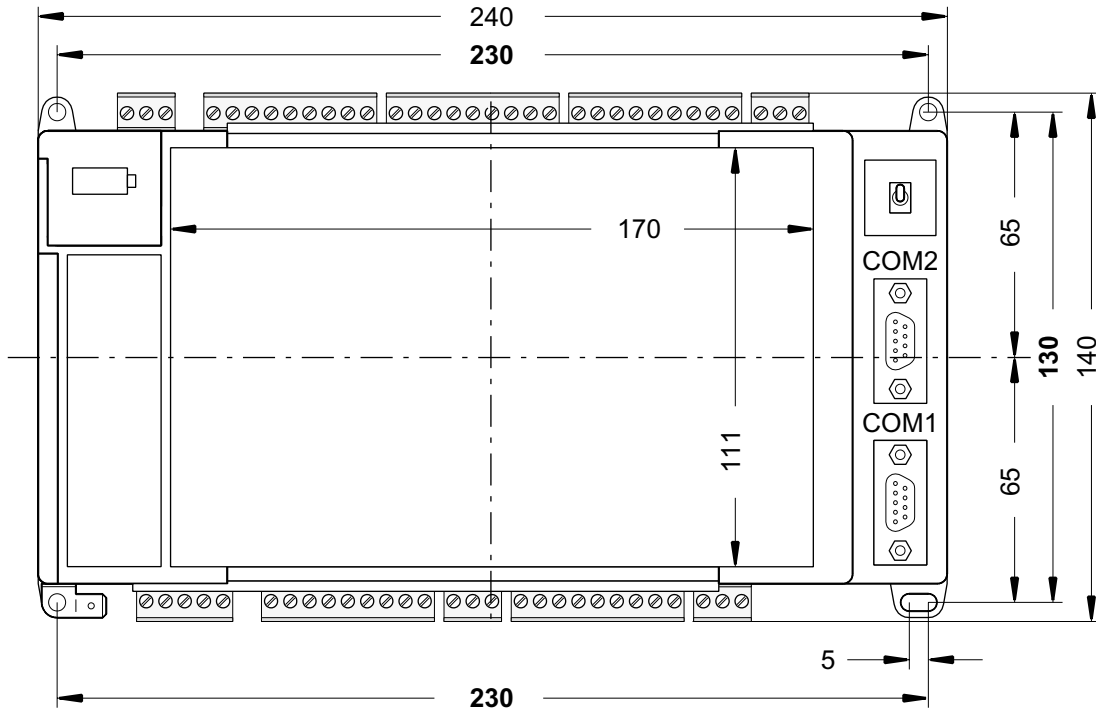

All dimensions in mm.

The device is 85 mm deep. The interface connectors COM1 and COM2 are set deeper so that the mounting depth required does not become any larger even with the interface cables plugged on. If, however, a DIN rail is used, the mounting depth is increased by the overall depth of the rail.

The dimensions for assembly bore holes are printed in bold.

3.6.14 Mounting hints

Mounting position	vertical, terminals above and below
Cooling	The natural convection cooling must not be hindered by cable ducts or other material mounted in the switch cabinet.

3.6.15 Ordering data

Central unit 07 KT 93-S R2171

Order No. GJR5 2513 00 R2171

Scope of delivery

Central unit 07 KT 93-S R2171
5 9-pole terminal blocks (5.08 mm grid)
1 5-pole terminal block (5.08 mm grid)
4 3-pole terminal blocks (5.08 mm grid)

Accessories

System cable 07 SK 90

Order No. GJR5 2502 00 R1

System cable 07 SK 91

Order No. GJR5 2503 00 R1

System cable 07 SK 92

Order No. GJR5 2504 00 R1

Battery module 07 LE 90

Order No. GJR5 2507 00 R1

Programming and test software and operating manual

(907 PC 33, 907 PC 331 and 907 PC 338 are required)

907 PC 33 German ¹⁾

Order No. GJP5 2039 00 R0302

907 PC 33 English ¹⁾

Order No. GJP5 2040 00 R0302

907 PC 331 German ²⁾

Order No. GJP5 2045 00 R0402

907 PC 331 English ²⁾

Order No. GJP5 2046 00 R0402

907 PC 338 German

Order No. GJP5 2067 00 R0102

907 PC 338 English

Order No. GJP5 2068 00 R0102

¹⁾ Description general part

²⁾ Description 07 KR 91 / 07 KT 92/93 specific part + software diskettes



Printed on chlorine-free bleached paper

ABB Schalt- und Steuerungstechnik GmbH
Eppelheimer Straße 82 Postfach 10 50 09
D-69123 Heidelberg D-69040 Heidelberg

Telefon +49 6221 777-0
Telefax +49 6221 777-111
E-Mail desst.helpine@de.abb.com
Internet <http://www.abb-sst.de>

Printed in the Federal Republic of Germany (08.99)

Central Unit
07 KT 93-S

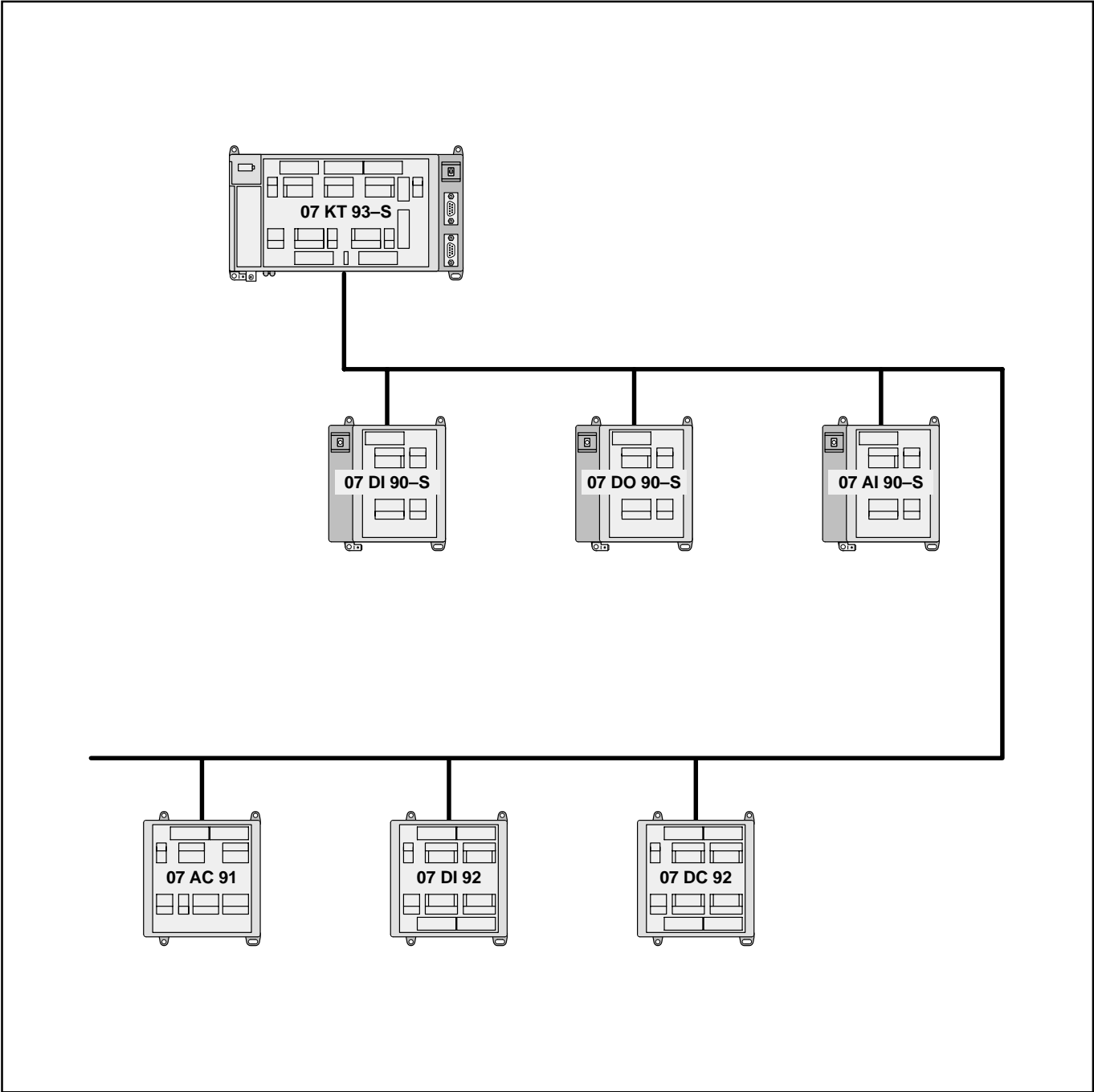

Table of Contents

Appendix

This documentation "Appendix" applies for the following central units:

07 KR 91 R202 and R252, R303 and R353
07 KT 92 R202 and R262
07 KT 93 R101 and R171
07 KT 93-S R2171

This documentation does **not** apply for the central units:

07 KT 94....

A1	Processing times	A1-1
A1.1	Program processing time t_{UP}	A1-1
A1.2	Set cycle time t_C	A1-2
A1.3	Reaction time in case of digital signals	A1-4
A2	Addressing with 07 KR 91 / 07 KT 92 / 07 KT 93 as bus master	A2-1
A2.1	Introduction / structure examples with 07 KR 91 / 07 KT 92 / 07 KT 93 as bus master	A2-1
A2.2	Recommended module addresses on the CS31 system bus with several remote modules and central units connected as slaves	A2-3
A2.3	Address setting for the modules	A2-3
A2.4	07 KR 91 / 07 KT 92 / 07 KT 93 used as bus master central unit	A2-4
A2.5	Intelligent I/O remote modules (central units) as slaves on the CS31 system bus ..	A2-5
A2.6	Special modules used as slave on the CS31 system bus	A2-7
A2.7	Complex structure examples including addresses	A2-7
A2.8	Module examples (slaves connected to the CS31 system bus)	A2-8

A3	I/O configuration	A3-1
A3.1	Purpose of I/O configuration of I/O modules	A3-1
A3.2	Settings and diagnosis on digital modules	A3-2
A3.3	I/O configuration, changing of measuring ranges and diagnosis on analog modules ..	A3-3
A3.3.1	Performing and reading the I/O configuration	A3-4
A4	Diagnosis	A4-1
A4.1	Introduction	A4-1
A4.2	Structure of the diagnosis	A4-1
A4.3	Troubleshooting by means of LED displays on the central unit	A4-2
A4.4	Troubleshooting on the remote modules	A4-4
A4.5	Acknowledgment of error messages in the remote modules	A4-5
A4.6	Example of an error message	A4-5
A4.7	Error flags in the central unit, error classification	A4-6
A4.8	Acknowledgment of error messages in the central unit	A4-8
A4.9	Additional diagnosis functions	A4-8
A4.10	Meaning of the contents of the error word flags	A4-8
A4.11	Reaction on bus master central unit and remote modules in case of errors	A4-13
A5	Programming and test	A5-1
A6	Man-machine communication (MMC) ...	A6-1
A7	Operands of 07 KR 91, 07 KT 92 and 07 KT 93 (variables and constants)	A7-1
A7.1	Freely available variables and constants ..	A7-1
A7.2	System constants / diagnosis flags / CS31 status (overview)	A7-1
A7.3	System constants / Setting of operating modes	A7-2
A8	The ARCNET system (Attached Resource Computer Network)	A8-1
A8.1	The networking configurations	A8-1
A8.2	The features of the ARCnet system	A8-3

A1 Processing times

The most important times for the application of the central units 07 KR 91 / 07 KT 92 / 07 KT 93, with or without connected remote modules, are:

- The **reaction time t_{kk}** is the time between a signal transition at the input terminal and the signal response at the output terminal.

In the case of digital signals, the reaction time consists of the input delay t_D , the cycle time t_C of the program processing and the bus transmission time, if the system is expanded by remote modules.

- The **cycle time t_C** determines the time intervals after which the processor starts the execution of the user program again.

The cycle time has to be specified by the user. It should be greater than the sums of program processing time t_{UP} of the user program, data transfer times, and related waiting times.

The cycle time is also the time base for some time-controlled functions, such as for the PID controller.

- The **program processing time t_{UP}** is the net time for processing the user program.

For the configuration and for determining the reaction time t_{kk} , the following steps are necessary:

- Determining the program processing time t_{UP}
- Addition of the other times which are within the cycle time t_C
- Specification of the cycle time t_C
- Determining the bus cycle time t_b , if there are any remote modules connected to the central unit
- Reaction time t_{kk} as the sum of the input delay t_D , 2 x bus cycle time t_b and 2 x cycle time t_C and output delay t_{DO} .

In addition to the calculation of cycle time t_C as described in chapter A1.2 (Appendix), it is possible to measure the capacity utilization on the programmed central unit (with the RUN/STOP switch set to RUN). The menu item "Display PLC status" in the programming software 907 PC 331 is used for this purpose. Increase the cycle time t_C until the capacity utilization is below 80 %.

A1.1 Program processing time t_{UP}

- **Binary instructions of the type:**

!M /M &M =M

!NM /NM &NM =NM

Processing time for 1000 instructions: 2 ms

!M /M &M =SM

!NM /NM &NM =RM

Processing time for 1000 instructions: 2.2 ms

- **Word instructions of the type:**

!MW +MW –MW =MW

!–MW –MW +MW =–MW

Processing time for 1000 instructions: 4.1 ms

!MW *MW :MW =MW

!–MW *–MW :–MW =–MW

Processing time for 1000 instructions: 5.4 ms

- **Mixed instructions**

– 65 % binary: !, /, &, =

– 20 % word: !, +, –, =

– 15 % word: !, *, :, =

Processing time for 1000 instructions: 3 ms

- The program processing times of all the function blocks are specified in the documentation of the programming software 907 PC 331.

A1.2 Set cycle time t_c

Times to be taken into consideration when the central unit 07 KR 91 / 07 KT 92 / 07 KT 93 is used as:				
	Stand-alone and slave, inputs and outputs of its own	Bus master, inputs and outputs of its own	Bus master, inputs and outputs via remote modules	Explanation
<p>The diagram shows a vertical timeline for the cycle time t_c. It is composed of several sequential blocks: a top block copy time t_{bc}, followed by an unpacking time t_{DP}, a program processing time t_{UP}, a packing time t_P, and a final block copy time t_{bc}. The total duration is indicated by a large double-headed arrow labeled t_c.</p>	$t_{bc} = 0.4 \text{ ms}$	$t_{bc} = \text{max. } 3.1 \text{ ms (1.5 ms) } *$	$t_k = \text{max. } 3.1 \text{ ms (1.5 ms) } *$	Block copy time, time for copying the input signals or the output signals from/to the transfer memory. It includes: <ul style="list-style-type: none"> - Net copy time 0.2 ms - 2 interface interrupts of 0.1 ms each - Waiting time for access authorization if expanded by remote modules: <ul style="list-style-type: none"> digital mod. only: 1.1 ms, also analog mod.: 2.7 ms (2 x interrogation time on the CS31 system bus)
	$t_{DP} = 0.1 \text{ ms}$	t_{DP}	t_{DP}	Time for unpacking. For each digital group (16 bits with common address) 0.05 ms. To be omitted for analog values.
	t_{UP}	t_{UP}	t_{UP}	Program processing time, see next page
	$t_P = 0.05 \text{ ms}$	t_P	t_P	Time for packing. For each digital group 0.05 ms. To be omitted for analog values.
	$t_{bc} = 0.4 \text{ ms}$	$t_{bc} = \text{max. } 3.1 \text{ ms (1.5 ms) } *$	$t_{bc} = \text{max. } 3.1 \text{ ms (1.5 ms) } *$	Block copy time, see above.

Figure 2-20: 07 KR 91 / 07 KT 92 / 07 KT 93, processing times

The cycle time t_c has to be preset by the user taking the following equation into consideration:

$$T_c \geq t_{bc} + t_{DP} + T_{UP} + t_P + t_{bc}$$

This equation assumes that the processor always gets access at the most unfavourable moment.

The cycle time t_c is stored in KD 00,00 and can be selected in 5 ms time steps. If the selected cycle time is too short, the processor will not be able to fulfil the tasks assigned to it and a time lag will occur.

If this lack of time becomes too large over several cycles, the processor will abort the program execution and report an error (FK2).

Using some function blocks, such as the PID controller, the error-free execution depends on an exact timing sequence. Make sure that there is a larger time reserve.

The correct setting of the cycle time can be checked by the following procedure:

- Load the user program into the central unit.
- If the operating mode has been switched over from stand-alone to bus master: Power ON or menu item "Enable PLC mode" in the programming software.
- Interrogation of the capacity utilization using the menu item "Display PLC status".
- Change the cycle time t_c until the capacity utilization is below 80 %.

Example: Bus master central unit + 1 digital input module + 1 digital output module + 2 analog input modules

Block copy time:	$t_{bc} = 3.1 \text{ ms}$
20 digital inputs of the central unit, 16 dig. inputs of the remote module, 3 groups (addresses): 62, 63, 8	$t_{DP} = 0.2 \text{ ms}$
user program:	$t_{UP} = 5 \text{ ms}$
12 digital outputs of the central unit, 8 dig. outputs of the remote module, 2 groups (addresses): 62, 10	$t_p = 0.1 \text{ ms}$
Block copy time:	$t_{bc} = 3.1 \text{ ms}$

Total	11.5 ms

The calculation results in a cycle time setting of $t_c = 15 \text{ ms}$.

A1.3 Reaction time in case of digital signals

		Times to be taken into consideration when the central units 07 KR 91 / 07 KT 92 / 07 KT 93 are used as:			
		Stand-alone and slave, inputs and outputs of its own	Bus master, inputs and outputs of its own	Bus master, inputs and outputs via remote modules	Explanation
Inputs of remote modules		-	-	$t_D = (8 \text{ ms})$	Input signal delay t_D of digital remote modules, normally typ. 8 ms
		-	-	$t_B > 2 \text{ ms}$	Cycle time t_B of the CS31 system bus, depending on number and type of the remote modules, see vol. 2, system data
Inputs of the central unit		$t_D = \text{typ. } 7 \text{ ms}$ or $8 \mu\text{s}$	$t_D = \text{typ. } 7 \text{ ms}$ or $8 \mu\text{s}$	-	Delay time t_D of digital inputs of the central unit: E 62,00...E 63,03: typ. 7 ms E 63,14 a. E63,15: typ. 8 μs
		$t_C \geq 5 \text{ ms}$	$t_C \geq 10 \text{ ms}$	$t_C \geq 10 \text{ ms}$	Cycle time t_C , to be set by the user
Outputs of the central unit		$t_D = 0$	$t_D = 0$	-	Delay time to of the outputs of the central unit: negligible
		-	-	$t_B > 2 \text{ ms}$	Cycle time t_B of the CS31 system bus, depending on number and type of the remote modules, see vol. 2, system data
Outputs of remote modules		-	-	$t_{Do} (< 1 \text{ ms})$	Output signal delay time of digital remote modules: normally < 1 ms

Figure 2-21: 07 KR 91 / 07 KT 92 / 07 KT 93, reaction time

The maximum reaction time t_{kk} (input terminal to output terminal) results from the asynchronicity of the operations:

- Central unit via its own inputs and outputs

$$t_{kk} = t_D + 2 \cdot t_C$$

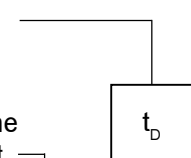
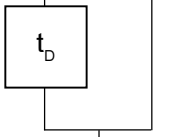
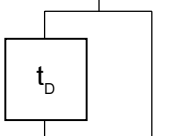
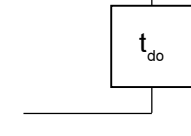
- Bus master central unit via inputs and outputs of remote modules

$$t_{kk} = t_D + 2 \cdot t_B + 2 \cdot t_{Do}$$

In case of analog signals, the refresh times are to be entered in the formula instead of the delay times.

A2 Addressing with 07 KR 91 / 07 KT 92 / 07 KT 93 as bus master (valid for 07 KR 91 (all types), 07 KT 92 R202/262, 07 KT 93 R101/171 and 07 KT 93-S R2171)

A2.1 Introduction Structure examples with 07 KR 91 / 07 KT 92 / 07 KT 93 as bus master

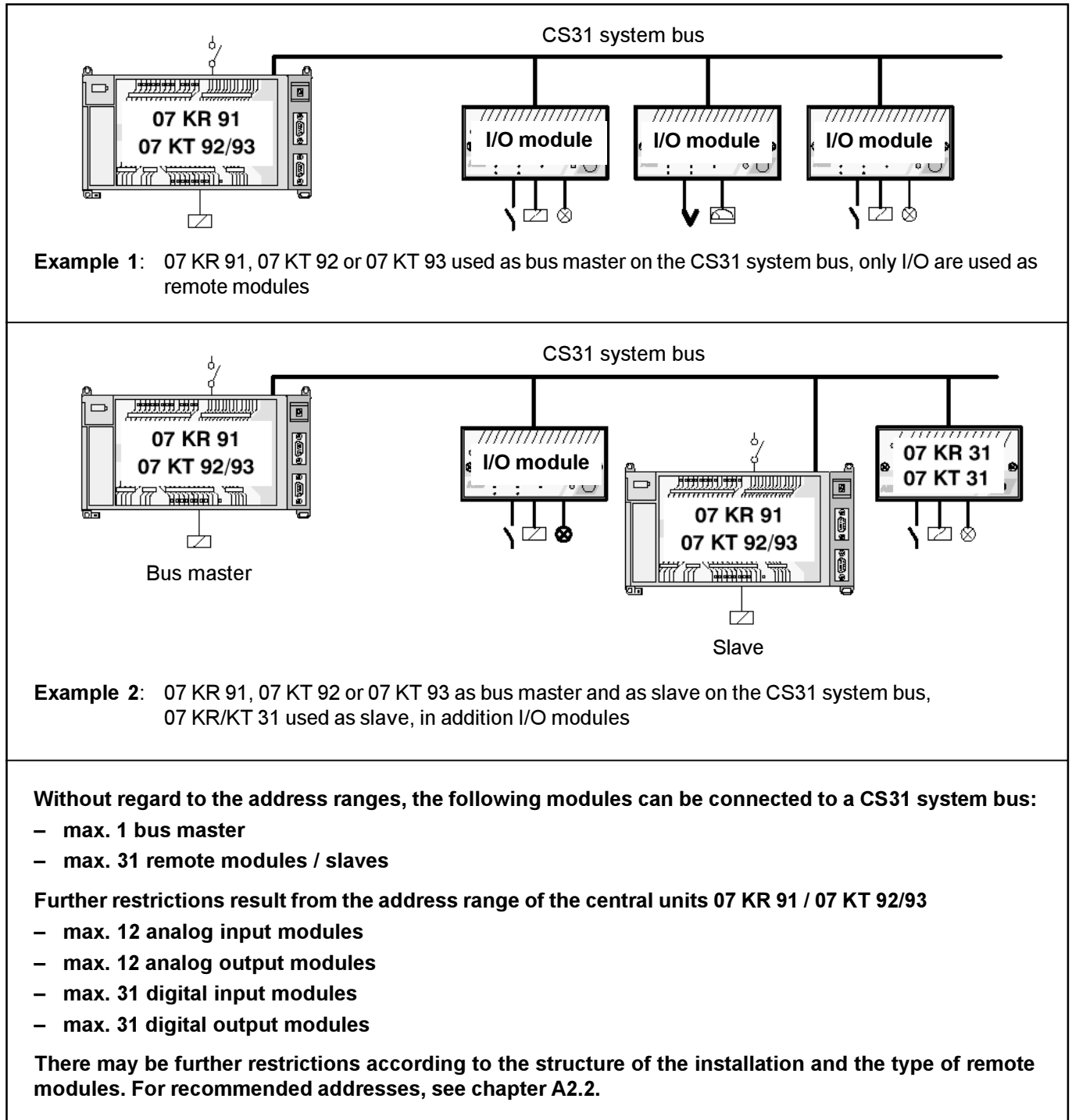

Structure of the input and output addresses in the remote modules

The digital input module ICSI 08 D1 is explained here as an example.

The bus master central unit reads the input signals as operands. The complete address of an input signal has the following structure:

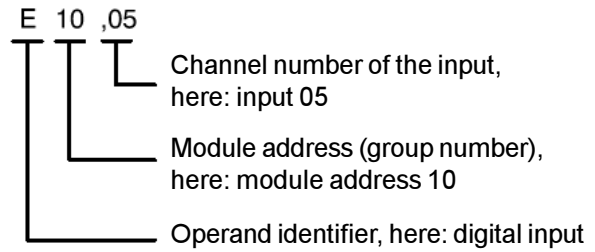

Setting of the module address (group number) on the plug-in base ECZ

Example: Digital input module ICSI 08 D1 results in variable identifier E

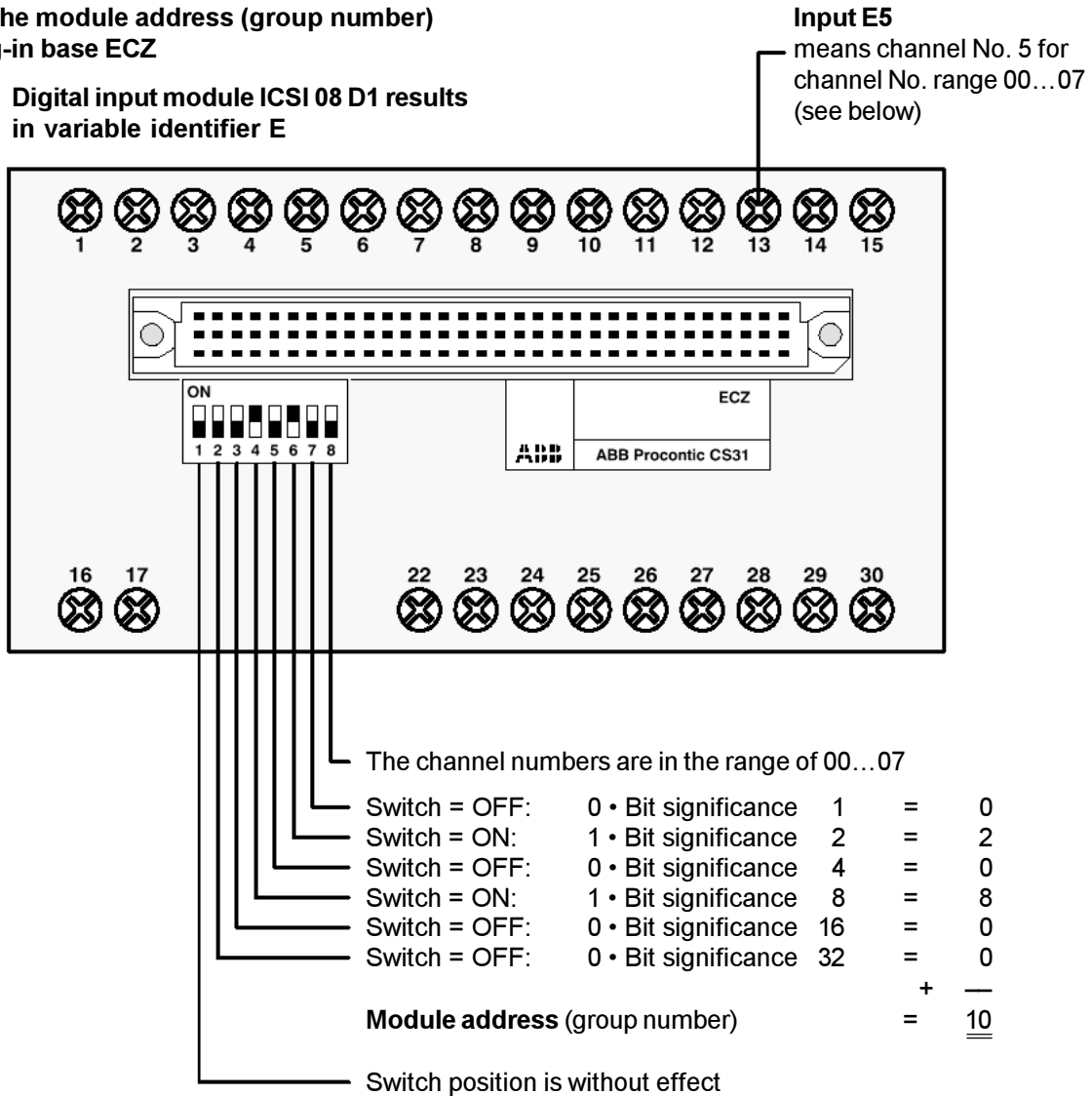

Note: Some of other modules may have a more or less different address setting, see the following chapters.

A2.2 Recommended module addresses on the CS31 system bus with several remote modules and central units connected as slaves

The standard addressing has the purpose of

- simplifying and schematizing the setting of addresses on the CS31 system bus
- simplifying diagnosis and troubleshooting.

The standard addressing makes sure that there will be no address overlappings even for modules with a larger amount of data.

Recommendation:

- Assign specific module address for each module / each slave central unit, that means giving up the possibility of double assignment of module addresses for digital and analog modules
- Module addresses for digital remote modules and central units: 8, 10, ..., 58, 60 (all even numbers), see also chapter A2.6 *Central units connected as slaves to the CS31 system bus*
- Module addresses for analog remote modules: 0...5
- Address switch No. 8 on the plug-in base ECZ always set to OFF (≤ 7)

A2.3 Address setting for the modules

Input and output modules connected as slaves to the CS31 system bus

The remote modules are mounted on the plug-in base ECZ. This plug-in base is equipped with an address switch (DIL switch) for setting the module address.

The combination of module type, module address and channel number results in the variable address used by the bus master central unit.

Setting the address switch for digital modules

The possible range of module addresses when using the central units 07 KR 91 / 07 KT 92 / 07 KT 93 is:

0...61

The function of the address switches is as follows:

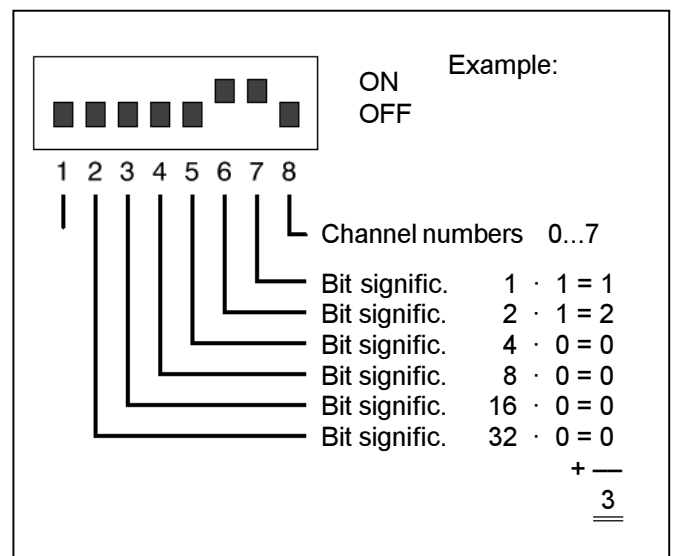
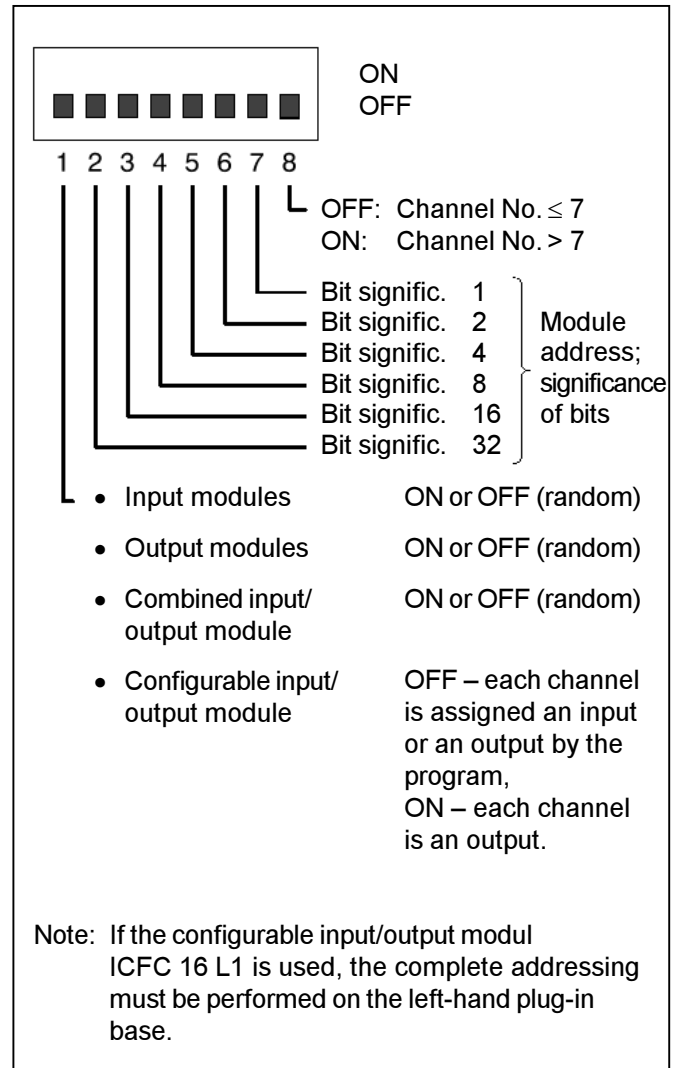

Setting the address switches using analog modules

If analog modules are used, their module addresses can be set to

0...5

when the central units 07 KR 91 / 07 KT 92 / 07 KT 93 are used as bus master.

The analog representation in the 07 KR 91 / 07 KT 92 / 07 KT 93 is fixed. The analog modules have to supply their values in a suitable form and therefore to be set to the analog representation **b**. For the analog representation, see the description of analog modules (general considerations for the use of analog modules).

The function of the address switches is as follows:

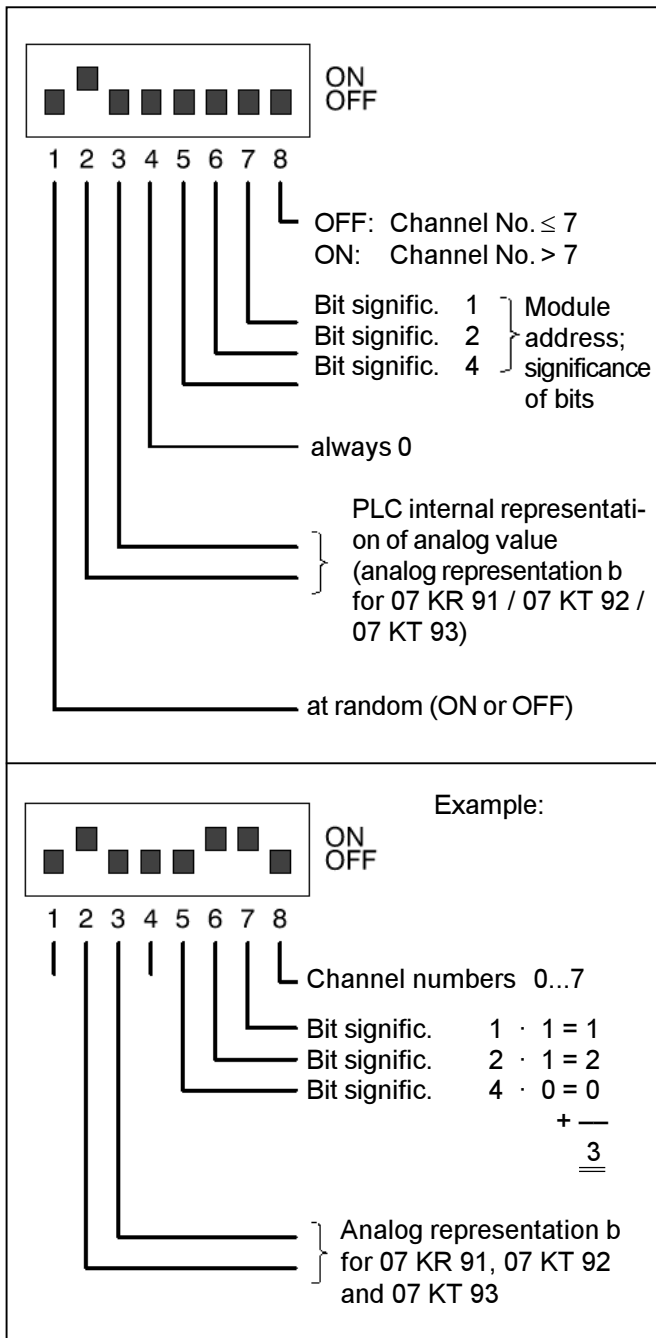

A2.4 07 KR 91 / 07 KT 92 / 07 KT 93 used as bus master central unit

If remote modules (slaves) are connected to the central units 07 KR 91 / 07 KT 92 / 07 KT 93 via the CS31 system bus, proceed as follows:

1. Change the system constant: KW 00,00 = -1
 2. Save the PLC program in the Flash EPROM
 3. Activate the new PLC mode by:
 - Calling up the menu item "Enable PLC mode" in the ABB programming and test system or
 - entering the command WARM <CR> in terminal mode
- or
- power ON or
 - cold start.

A2.5 Intelligent I/O remote modules (central units) as slaves on the CS31 system bus

The central units 07 KR 91, 07 KT 92, 07 KT 93, 07 KR 31 and 07 KT 31 can also be used as slaves at the CS31 system bus, see Chapter A2.1, Addressing, Introduction, Example 2.

The central units 07 KR 91 / 07 KT 92 / 07 KT 93 / 07 KR 31 / 07 KT 31 may be used both in the binary range and in the word range.

The address can be set to a value from 0 to 61. The maximum permissible address depends on the size of the set transmit and receive range. The larger you choose the transmit or the receive range, the smaller the maximum permissible address is (see examples 1...3).

If you want to switch over to the "slave mode", proceed as follows:

1. Change the system constant: KW 00,00 = 0...61.
Only for 07 KR 31 and 07 KT 31: If KW 00,00 = 100, the address is set on the DIL switch of the plug-in base in the same way as with the standard modules, the address range is 0...61.

Meaning of the DIL switches:

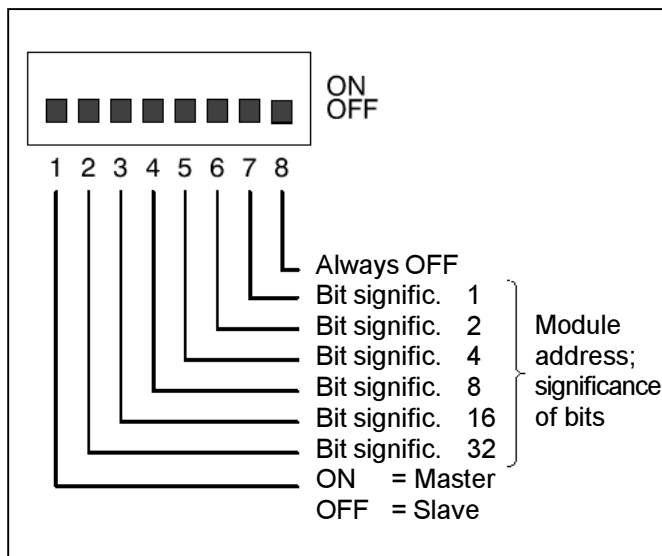

2. Save the PLC program in the EEPROM
3. Activate the new PLC mode by:
 - Calling up the menu item "Enable PLC" mode in the ABB programming and test system or
 - entering the command WARM <CR> in terminal mode or
 - power ON or
 - cold start.

There is no direct access to the inputs and outputs of the slave central unit via the CS31 system bus. The communication between master and slave is performed using input and output operands.

All master data are consistently transferred to the slave, and all slave data are consistently transferred to the master.

The slave PLC can be used either in the binary range or in the word range of the CS31 system bus. The transmit and receive ranges of the slave can be adapted to the application-specific requirements by means of the two system constants KW 00,10 and KW 00,11 (see also chapter "System constants").

You can set:

- The size of the transmit and receive ranges and
- the mode of employment of the slave (in the binary or the word range).

Default condition:

If the central units 07 KR 91 / 07 KT 92 / 07 KT 93 / 07 KR 31 / 07 KT 31 are switched over to the "slave mode", they behave like digital input and output modules with 32 inputs and 32 outputs when connected to the CS31 system bus.

This means that the default setting of the transmit and receive ranges is within the binary range of the master. Their size is 32 bits each (4 bytes).

Example 1:

Default configuration of the slave (binary range):

KW 00,10 = 0: Slave transmit range: 4 bytes
(4 bytes * 8 channels = 32 digital O)
KW 00,11 = 0: Slave receive range: 4 bytes
(4 bytes * 8 channels = 32 digital I)

Note:

The default configuration is the same as the configuration KW 00,10 = KW 00,11 = 4.

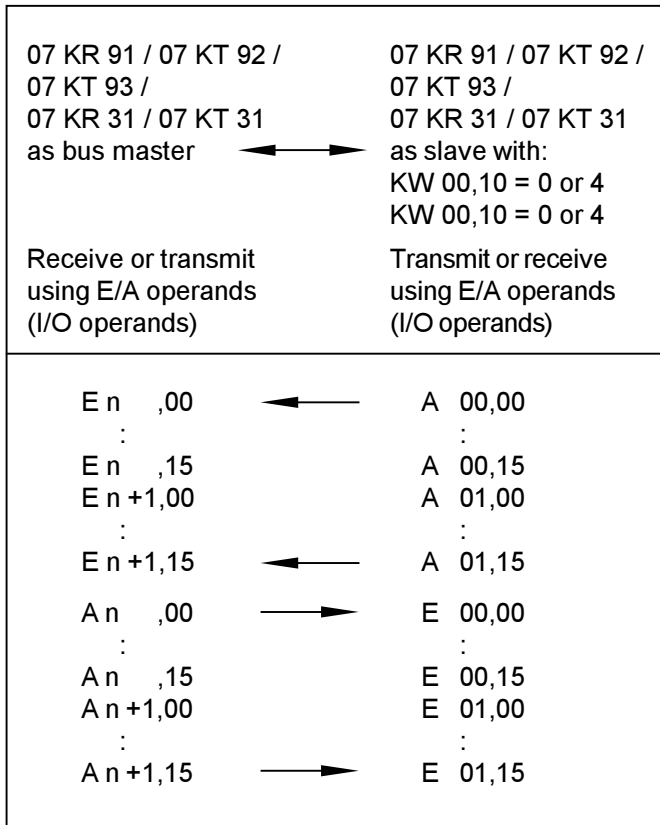

n: Module address of the slave PLC (for this example:
0 ≤ n ≤ 60)

For the slave address of n = 12 the following example
applies:

The output signal A 00,00 of the 07 KR 91 used as slave
is the input signal E 12,00 for the 07 KR 91 used as bus
master.

Example 2:

Configuration of the slave for the binary range:

KW 00,10 = 15: Slave transmit range: 15 bytes
(15 bytes * 8 channels = 120 digital O)

KW 00,11 = 06: Slave receive range: 6 bytes
(6 bytes * 8 channels = 48 digital I)

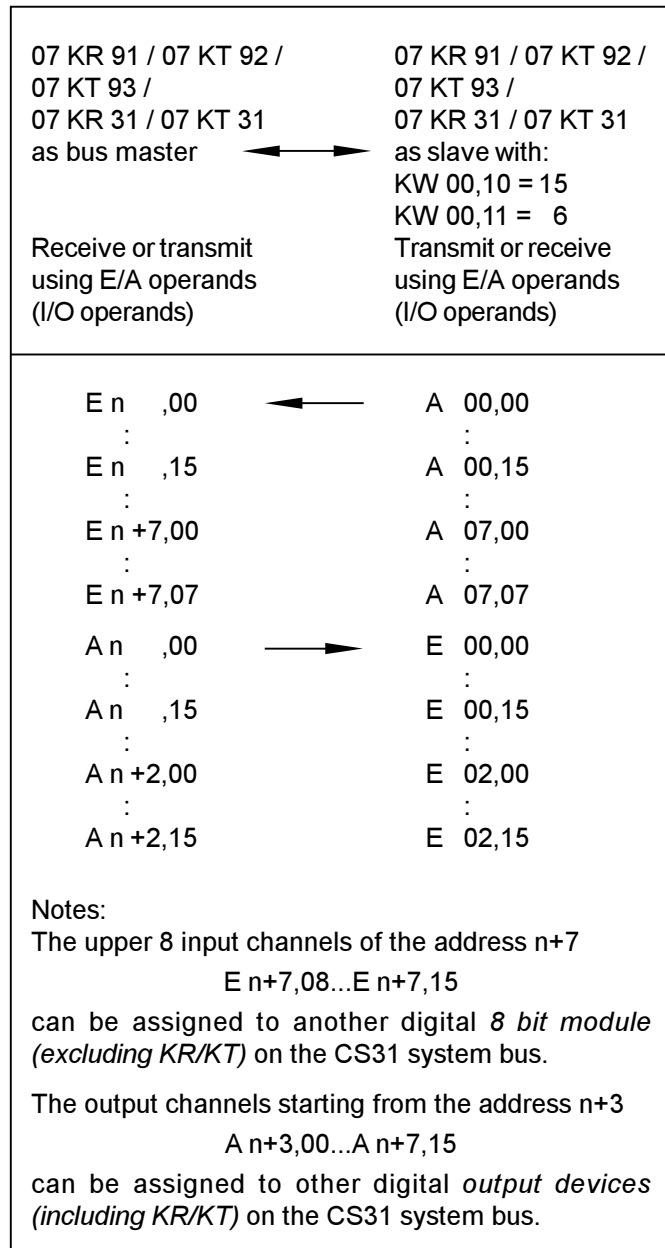

n: module address of the slave PLC (for this example:
0 ≤ n ≤ 54)

For the slave address n = 12, the following example
applies:

The output signal A 00,00 of the 07 KR 91 used as slave
is the input signal E 12,00 for the 07 KR 91 used as bus
master.

Example 3:

Configuration of the slave for the word range:

KW 00,10 = 101: Slave transmit range: 1 word
(1 word = 1 word output)

KW 00,11 = 108: Slave receive range: 8 words
(8 words = 8 word inputs)

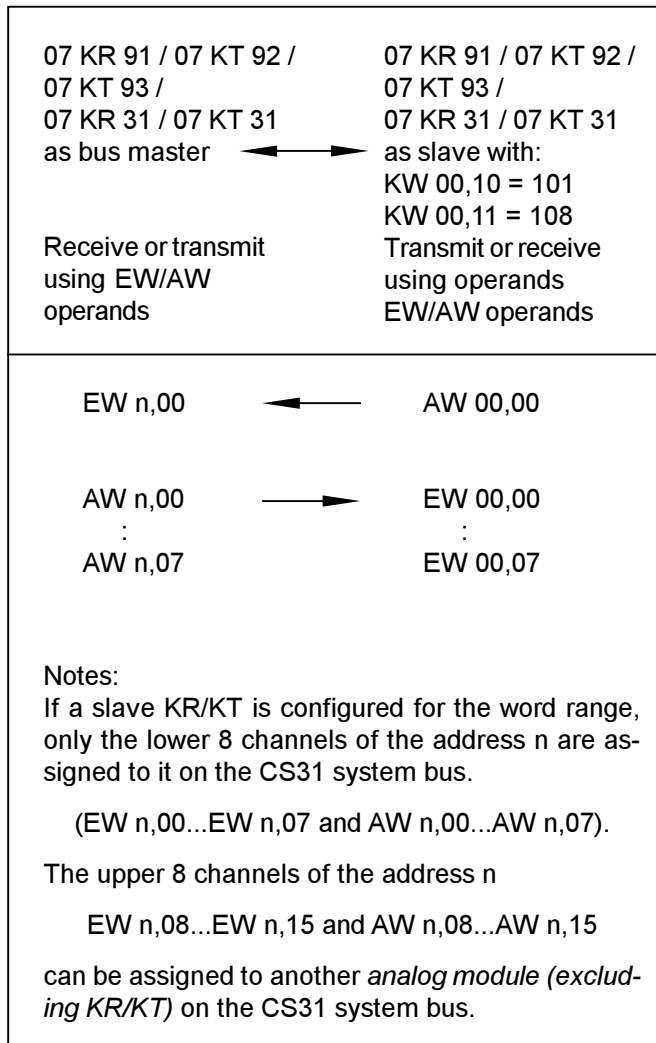

n: module address of the slave PLC (for this example:
 $0 \leq n \leq 5$)

For the slave address of n = 4 the following applies, for example:

The output signal AW 00,00 of the 07 KR 91 used as slave is the input signal EW 04,00 for the 07 KR 91 used as bus master.

A2.6 Special modules used as slave on the CS31 system bus

• Robot coupler ICBG32L7 and ICBG64L7

The Robot coupler ICBG32L7 (ICBG64L7) behaves on the CS31 system bus like a digital input/output module equipped with 16 (32) inputs and 16 (32) outputs.

The module address can be set by means of the DIL switch on the printed circuit board.

The meaning of the DIL switch is the same as that on the plug-in base ECZ, see chapter A2.3. Switch No. 8 is always set to OFF.

Please note that the set module address and also the following address are assigned by the Robot coupler ICBG64L7.

For the signal names in the user program of the central unit, see the description of the Robot couplers.

• Festo valve island/ installation island

The Festo valve island and the Festo installation island behave on the CS31 system bus like digital input and output modules. For the scope of assigned data, see chapter A2.9.

The module addresses are set by means of the address switches located under the cover of the "field bus node". The upper switch is provided for the units digit, the lower switch for the tens digit.

A2.7 Complex structure examples including addresses

• Categorization of the modules with respect to the I/O terminals

There are the following two main module types:

- Digital modules. These modules are controlled by means of digital I/O operands (E or A, respectively). The Robot couplers ICBG 32 L7 and ICBG 64 L7 (always used as slave) belong also to them, as well as the central units 07 KR 91, 07 KT 92, 07 KT 93, 07 KR 31 and 07 KT 31, if they are used as slaves.
- Analog modules. These modules are controlled by means of word I/O operands (EW or AW, respectively). The central units 07 KR 91, 07 KT 92, 07 KT 93 belong to them as well as the high-speed counter ICSF 08 D1, which receives its preset data as word data, for example.

The following table contains an overview of the module types. These designations will be used in example 6.

Please note that the configurable digital modules ICSC 08 L1 and ICFC 16 L1 behave differently according to the performed setting.

A2.8 Module examples (slaves connected to the CS31 system bus)







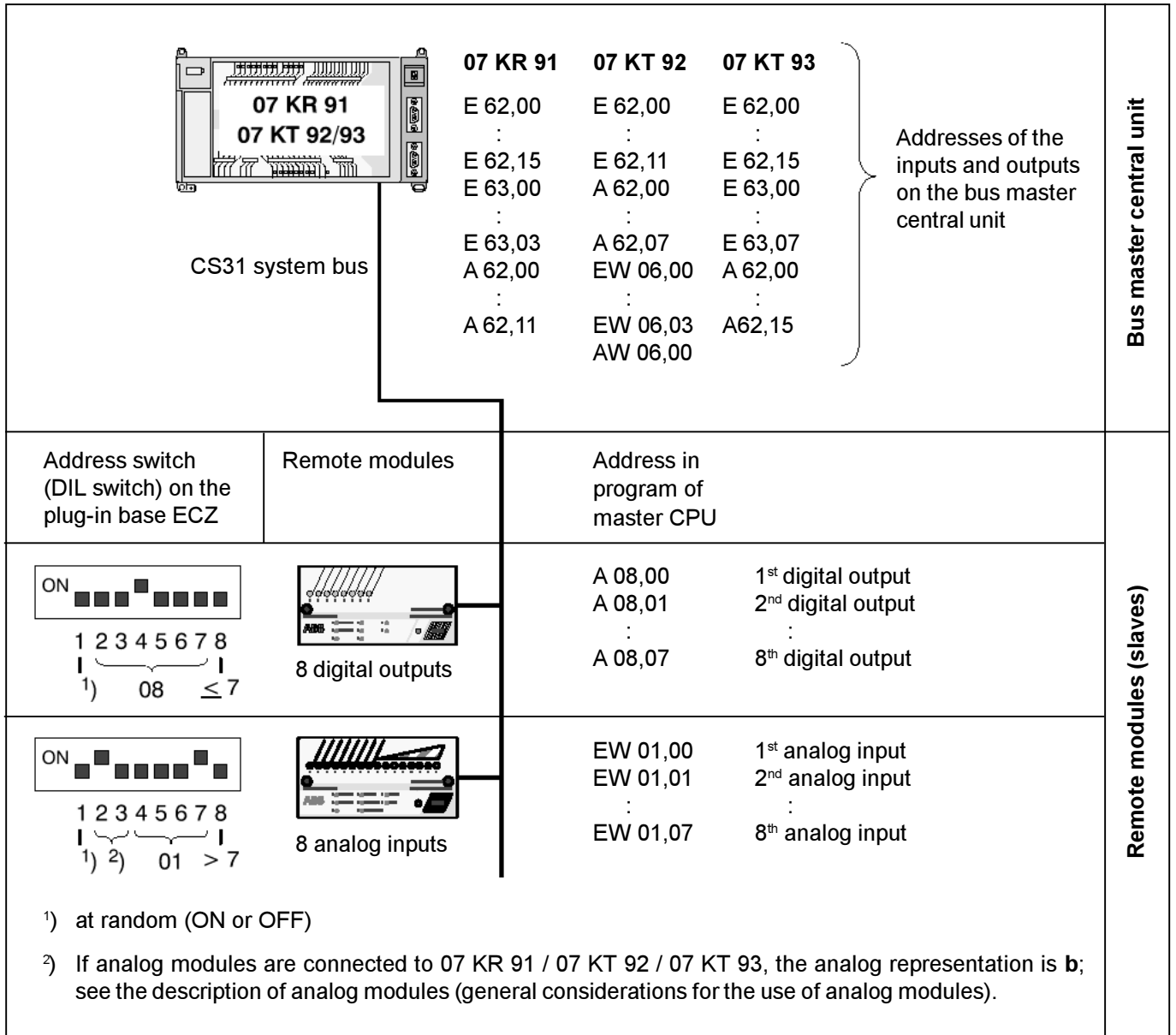

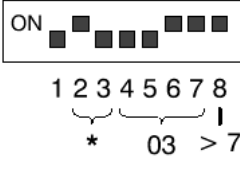

Module types, with regard to I/O terminals	Module examples	Module types, with regard to I/O terminals	Module examples
Digital input modules with 8 inputs	ICSI 08 D1, ICSI 08 E1, ICSI 08 E4	Analog output modules with 8 outputs	ICSA 04 B5
Digital input modules with 16 inputs	ICSI 16 D1, ICSI 16 E1	Analog modules with up to 4 inputs and 4 outputs	ICSM 06 A6 (4 IA, 2 OA, therefore addressing gaps which cannot be assigned)
Digital output modules with 8 outputs	ICSO 08 R1, ICSO 08 Y1, ICSC 08 L1, if switch No. 1 is set to ON	Analog modules (word modules) with up to 8 inputs and 8 outputs	ICSF 08 D1 (high-speed counter) 07 KR 91, 07 KT 92, 07 KT 93, 07 KR 31, 07 KT 31
Digital output modules with 16 outputs	ICFC 16 L1, if switch No. 1 is set to ON, Festo valve island with up to 8 valves		
Digital output modules with 32 outputs	Festo valve island with more than 8 valves		
Digital modules with 8 inputs and 8 outputs	ICSC 08 L1, if switch No. 1 is set to OFF		
Digital modules with 16 inputs and 16 outputs (a) or 16 signals each from/to the CS31 bus (b)	(a) ICSK 20 F1, ICDG 31 L1, if switch No. 1 is set to ON, ICFC 16 L1, if switch No. 1 is set to OFF, Festo installation island with up to 6 valves, (b) ICBG 32 L7		
Digital modules with 32 inputs and 32 outputs (a) or 32 signals each from/to the CS31 bus (b)	(a) Festo installation island with more than 6 valves, (b) ICBG 64 L7, ICBG 32 L1, if switch No. 1 is set to OFF		
Digital modules with 120 signals each from/to the CS31 system bus	07 KR 91 as slave 07 KT 92 as slave 07 KT 93 as slave 07 KR 31 as slave 07 KT 31 as slave		
Analog input modules with 8 inputs	ICSE 08 A6, ICSE 08 B5, ICST 08 A8, ICST 08 A9		

Examples for the assignment of module addresses

Example 4

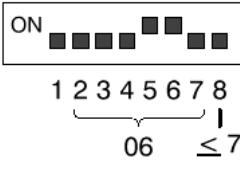

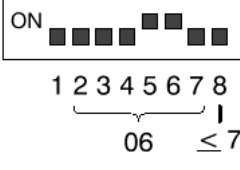
Example 5

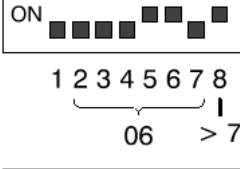
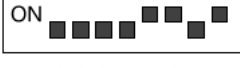
		07 KR 91	07 KT 92	07 KT 93	Inputs/ outputs on the central unit
Address setting in the master: KW 0,0 = -1		E 62,00...E 62,15 E 63,00...E 63,03 A 62,00...A 62,11 — —	E 62,00...E 62,11 — A 62,00...A 62,07 EW 6,00...EW 6,03 AW 6,00	E 62,00...E 62,15 E 63,00...E 63,07 A 62,00...A 62,15 — —	
Address switch on plug-in base ECZ	Remote module	Address in program of master CPU		Remarks	
 <p>ON  1 2 3 4 5 6 7 8 * 03 ≤ 7</p>	ICSE 08 A6 8 analog inputs	E0 : E7	EW 03,00 : EW 03,07	<ul style="list-style-type: none"> – Permissible range of module addresses for analog modules: 0...5 – Analog representation b – 2 analog input modules with 8 channels each can be assigned to one address (16 channels altogether) – The same address (as for the analog input modules) may also be used for the connection of analog output modules (as shown to the left). <p>Since the module has only 4 channels, AW 03,04...AW 03,07 (or AW 03,12...AW 03,15) cannot be used. The same corresponds to the module ICSM 06 A6.</p>	
 <p>ON  1 2 3 4 5 6 7 8 * 03 > 7</p>	ICSE 08 A6 8 analog inputs	E0 : E7	EW 03,08 : EW 03,15		
 <p>ON  1 2 3 4 5 6 7 8 * 03 ≤ 7 * Analog representation b</p>	ICSA 04 B5 4 analog outputs	A0 : A3	AW 03,00 : AW 03,03		
 <p>ON  1 2 3 4 5 6 7 8 06 ≤ 7</p>	ICSI 16 E1 16 digital inputs	E00 : E15	E 06,00 : E 06,15	<ul style="list-style-type: none"> – Permissible range of module addresses for digital modules: 0...61, recommendation: 6...60 – The following is admissible, but without any advantages: <ul style="list-style-type: none"> • using the same addresses for digital modules as for analog modules • collecting 2 modules with 8 bits each under one address • collecting input and output modules under one address – Slave KR/KT with 120 E and/or 120 A occupies the set address and the following 7 addresses (only half of the 7th, however) <p>For address 4 of the example:</p> <ul style="list-style-type: none"> – Next free address for KR/KT: binary range: 12, word range: 5 – Max. settable KR/KT address: binary range: 54, word range: 5 	
 <p>ON  1 2 3 4 5 6 7 8 06 ≤ 7</p>	ICSO 08 R1 8 digital outputs	A0 : A7	A 06,00 : A 06,07		
 <p>ON  1 2 3 4 5 6 7 8 06 > 7</p>	ICSO 08 R1 8 digital outputs	A0 : A7	A 06,08 : A 06,15		
<div style="border: 1px solid black; padding: 5px; display: inline-block;"> 07 KR 91 / 07 KT 92 / 07 KT 93: KW 0,0 = 4 </div> <p>up to 120 digital inputs and up to 120 digital outputs or up to 8 word inputs and up to 8 word outputs</p>		KR/KT in binary range: E 04,00...E 11,07 A 04,00...A 11,07 or KR/KT in word range: EW 04,00...EW 04,07 AW 04,00...A 04,07			

Example 6

Module type, with respect to I/O terminals	Address switch on plug-in base ECZ	07 KR 91 / 07 KT 92 / 07 KT 93	Permissible addresses
8 analog inputs Address 0, ≤ 7 8 analog inputs Address 0, > 7 8 analog outputs Address 0, ≤ 7 8 analog outputs Address 0, > 7 4 analog inputs and 4 analog outputs Address 1, ≤ 7 4 analog inputs and 4 analog outputs Address 1, > 7	<div style="text-align: center;"> 1 2 3 4 5 6 7 8 </div>	EW 0,00...EW 0,07 EW 0,08...EW 0,15 Collection is possible AW 0,00...AW 0,07 AW 0,08...AW 0,15 EW 1,00...EW 1,03 AW 1,00...AW 1,03 EW 1,08...EW 1,11 AW 1,08...AW 1,11	0...5 (2=ON, 3=OFF: Analog re- presentati- on b)
8 digital inputs Address 0, ≤ 7 8 digital inputs Address 0, > 7 8 digital outputs Address 0, ≤ 7 8 digital outputs Address 0, > 7 16 digital inputs Address 1, ≤ 7 16 digital outputs Address 1, ≤ 7 32 digital outputs Address 2, ≤ 7 8 digital inputs and 8 digital outputs Address 4, ≤ 7 8 digital inputs and 8 digital outputs Address 4, > 7 16 digital inputs and 16 digital outputs Address 5, ≤ 7 32 digital inputs and 32 digital outputs Address 6, ≤ 7	<div style="text-align: center;"> </div>	E 0,00...E 0,07 E 0,08...E 0,15 Collection is possible A 0,00...A 0,07 A 0,08...A 0,15 E 1,00...E 1,15 Collection is possible A 1,00...A 1,15 A 2,00...A 2,15 A 3,00...A 3,15 E 4,00...E 4,07 A 4,00...A 4,07 Collection is possible E 4,08...E 4,15 A 4,08...A 4,15 E 5,00...E 5,15 A 5,00...A 5,15 E 6,00...E 6,15; E 7,00...E 7,15 A 6,00...A 6,15; A 7,00...A 7,15	0...61 (please note this also for double addresses) A gapless assignment, as selected here, is not mandatory.

See this chapter A2.8 for module examples

Max. 31 slave modules on the CS31 system bus

A3 I/O configuration

A3.1 Purpose of I/O configuration of I/O modules

Depending on the type of I/O modules, the following can be configured:

- for digital I/O modules, an input delay different from the factory setting,
- for digital modules with combined I/O channels, these channels can also be defined as input only or output only,
- for digital modules, open-circuit monitoring at inputs and outputs,
- for analog modules, measuring or output ranges which differ from the factory setting.

Switching over of inputs and outputs, switching on the diagnosis functions and changing the measuring and output ranges are performed as follows, depending on the module type:

- Performing the I/O configuration via the CS31 system bus, either by means of the user program of the bus master central unit or by means of a terminal
- Setting of switches on the plug-in base ECZ or on the rear side of the input/output module
- External wiring on the input/output module terminals.

In some cases, there is a relation between the settings made on the remote module and the information and diagnosis messages which can be interrogated at the remote module or via the CS31 system bus. This relation will be explained below.

There is no need for you to perform an I/O configuration via the CS31 system bus if the factory setting is sufficient. Once an I/O configuration has been performed, it will remain stored in the corresponding I/O module until it is changed again. Even in case of power OFF it will not be deleted.

A3.3 I/O configuration, changing of measuring ranges and diagnosis on analog modules

Analog modules, settings and diagnosis										
Selectable ranges: I/O configurable (K) by means of switches (S) or wiring (V)				0...10 V	± 10 V	0...20 mA	± 20 mA	4...20 mA	other range	rough display of value
Module type										
ICSE 08 A6	•	•		A	–	A	–	K	K	•
ICSE 08 B5	•	•		–	A	–	S, K	S, K	S, K	•
ICSA 04 B5	•	•	•	–	A	S	–	S, K*	–	•
ICSM 06 A6, inputs	•	•		A	–	A, V	–	K	A, K	•
ICSM 06 A6, outputs				–	A	A	–	K		•
Diagnosis functions acc. to module type										
a) always available	UE	BE								
b) if configured			OE							
Can be read from module by pressing test button ¹⁾										
a) Diagnosis messages	UE	BE								
b) Settings (only switches and I/O configuration)			OE	•	•	•	•	•		
Available for bus master user program, can be read on terminal										
a) transferred cyclically	UE	BE								
b) can be interrogated			OE					•		

Key:

- ¹⁾ For information about the interrogation of settings and diagnosis data, see the module description and chapter "Reading I/O configuration and diagnosis data at the module" (see below).
- ^{*)} Changing range by switch, activating the open-circuit monitoring by I/O configuration
- BE** Bus Error = Bus malfunction, always monitored. The module does not receive a call from the bus master, e.g. because of a broken bus line.
- OE** Output Error = Error in the output circuit.
 ICSA 04 B5: Open circuit at outputs configured to 4...20 mA.
 ICSM 06 A6: Short circuit at outputs configured to ± 10 V.

- UE** Unit error = internal error (fault) of the module (always monitored in so far as the internal processor can detect this).
- A** Factory setting
- K** Changing the range by means of the I/O configuration via the CS31 system bus
- S** Changing the range by means of DIL switches on the rear side of the module
- V** Change-over between voltage and current by means of an additional external jumper. No specification if only another terminal has to be used.

A3.3.1 Performing and reading the I/O configuration

There are the following possibilities for system structures when using 07 KR 91, 07 KT 92 or 07 KT 93 as bus master:

- Performing and reading the I/O configuration via the user program of the bus master central unit 07 KR 91, 07 KT 92 or 07 KT 93,
- Performing and reading the I/O configuration by means of the terminal or
- Reading the I/O configuration from the remote modules.

Performing and reading the I/O configuration via the user program

The function block CS31CO is available for the I/O configuration of the modules. This function block is part of the programming software 907 PC 331 and is described in the corresponding documentation.

Performing and reading the I/O configuration by means of the terminal or TCZ

This method is based on the fact that the central units 07 KR 91, 07 KT 92 and 07 KT 93 use a dialogue language at the programming interface which allows the I/O configuration to be performed and interrogated by means of simple protocols; see volume 7.3, chapter 3, *MAIL command*.

07 KR 91 and 07 KT 92/93 are generally equipped with the special function for I/O configuration.

The following devices can be used as terminal:

- A commercially available terminal equipped with an EIA-232 interface, such as VT100.
- A PC equipped with the programming software 907 PC 331. All the interface data are correctly set under the main menu item of "PLC communication 2", sub-item "Terminal emulation".
- The service device TCZ in the operating mode
1 = TERMINAL, 2 = CHAR.MODE, N = transmission speed unchanged, 9600 Baud.

Reading I/O configuration and diagnosis data at the remote module

Reading the I/O configuration and the diagnosis data for an I/O terminal of a remote module will be shown in the following for the device ICSC 08 L1 as an example. The test button (4) and the LED displays (1) of the module must be used for this purpose.

When the test button is pressed for the first time, channel E/A0 (input/output 0) is selected: LED 0 flashes. After releasing the button, the diagnosis data of this channel are shown by the yellow LEDs 0 to 7 for approx. 3 seconds.

LED key:

- 0 UE = Unit error
- 1 BE = Bus error
- 2 not used
- 3 CI/CO = Cut wire of inputs/outputs
- 4 OL = Overload
- 5 SC = Short circuit
- 6 Configuration as output
- 7 Configuration as input

If the LEDs 6 and 7 light up at the same time, the channel is configured as a combined input/output.

The LED key (2) is also printed on the front panel of the module.

The operation is repeated for the other channels each time the test button is pressed and released.

After the last channel E/A7 (input/output 7) has been scanned, pressing the test button again causes a lamp test (LED test) to be performed. All the 8 LEDs should light up. After the button has been released, the LEDs will show the setting of the DIL switch on the plug-in base for approx. 5 seconds. LED 0 shows the position of switch No. 1 (LEDs 0...7 are assigned to the switches No. 1...8).

All error messages are stored in the module and can only be deleted by pressing the test button for 10 seconds or by power OFF/ON.

A4 Diagnosis

A4.1 Introduction

The diagnosis system of the 07 KR 91 / 07 KT 92 / 07 KT 93 is designed to ensure quick and efficient troubleshooting. For this purpose, it is organized:

- “vertically” in diagnosis, error flags, reactions, LED displays and acknowledgment (see section A4.7). There are interrelations between the bus master central unit and the remote modules. The central unit reads diagnosis data found by the remote modules. A central unit acknowledgment also causes stored error messages in the remote modules to be deleted.
- “horizontally” in 4 error classes, corresponding to the severity of the error, see section A4.7.

The system structure consists of a bus master central unit and several remote modules, and remote processors as well. The diagnosis system detects the following errors:

- Errors in the bus master central unit
- Errors on the CS31 system bus

- Errors in the remote modules
- Errors in the wiring of the remote modules on the process side

Troubleshooting is performed as follows:

- LEDs on the central unit 07 KR 91, 07 KT 92 and 07 KT 93 give first hints (see section A4.3). Errors detected by remote modules are also displayed here.
- If these hints are not sufficient, the error flags have to be read out. For meanings of error flags, see sections A4.7 and A4.10.
- The status register EW 07,15 in the central unit supplies additional information used for diagnosis (see section A4.9).
- The remote modules indicate errors occurring in their area. Detailed information can be obtained by pressing the test key on the modules (see chapter A4.4).

A4.2 Structure of the diagnosis

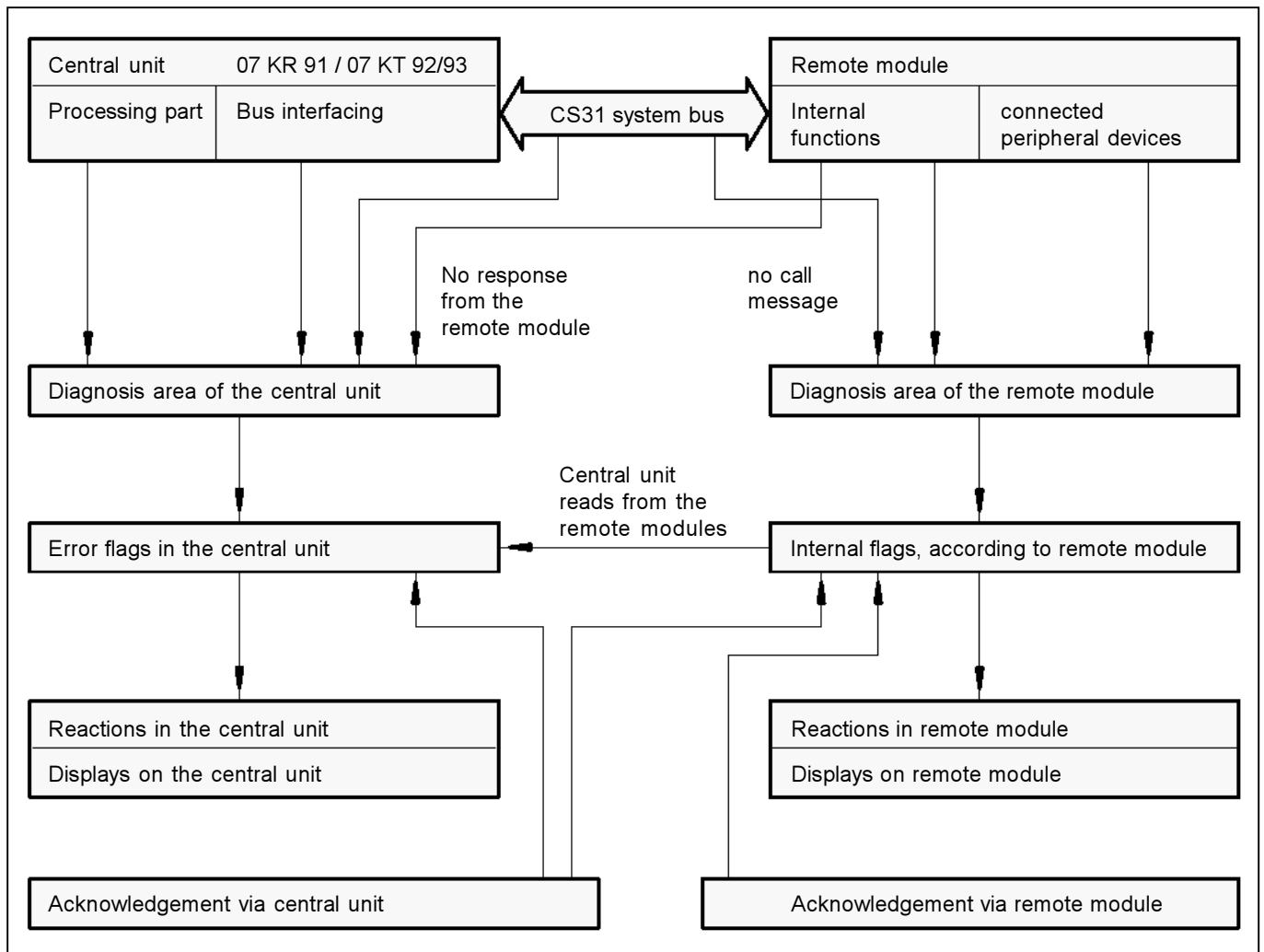

A4.3 Troubleshooting by means of LED displays on the central unit

The LED displays on the front panel of the central unit supply initial information on the errors which occurred:

- BA = CS31 bus processor active
- BE = Bus Error (error on the CS31 system bus)
- RE = Remote Unit Error (error in/on a remote module)
- SE = Serial Unit Error (error in the CS31 bus interfacing of the central unit)
- RUN = User program is running (no error)

- FK1 = Error class 1 (fatal error)
- FK2 = Error class 2 (serious error)
- FK3 = Error class 3 (light error)
- Supply = Supply voltage available
- Battery = Battery is effective
- K = Overload/short circuit on at least one direct digital output of the central unit 07 KT 92 or 07 KT 93

If no LED lights up, the central unit has not found any error. Exception: LED "Battery" (battery is missing); the battery is only necessary for certain applications.

LEDs for CS31 system bus and bus interfacing

LED	BA	BE	RE	SE	Significance	Remedy
CPU	gn	rd	rd	rd		
Stand alone CPU, master CPU or slave CPU	*	o	o	o	Everything ok.	--
	o	⌘	⌘	⌘	A fatal error occurred. The watchdog switched off the CS31 system bus. All outputs are in OFF condition.	<ul style="list-style-type: none"> • Power OFF/ON. If unsuccessful, device is defective. • Evaluate error flags.
	*	o	o	*	Dual-port RAM defective.	<ul style="list-style-type: none"> • Power OFF/ON. If unsuccessful, device is defective. • Evaluate error flags.
	o	*	*	*	Initialization phase after power ON or after cold start.	--
Master CPU	*	*	o	o	Master CPU does not find any remote modules on the CS31 system bus <u>after</u> power ON or after cold start	<ul style="list-style-type: none"> • Install remote modules. • Check CS31 bus line. • Check supply voltage of remote modules. • Evaluate error flags.
	*	o	*	o	Error message from a remote module	<ul style="list-style-type: none"> • Evaluate error flags. • Check remote modules.
	*	*	*	o	1 remote module suddenly can no longer be controlled by the master CPU .	<ul style="list-style-type: none"> • Evaluate error flags. • Check supply voltage of remote module. • Check CS31 bus line. • Check remote module.
	*	*	o	o	There are at least 3 remote modules on the CS31 system bus. 2 remote modules suddenly can no longer be controlled by the master CPU.	<ul style="list-style-type: none"> • Evaluate error flags. • Check supply voltage of remote modules. • Check CS31 bus line. • Check remote modules.
	*	*	*	*	There are at least 2 remote modules on the CS31 system bus. All remote modules suddenly can no longer be controlled by the master CPU.	<ul style="list-style-type: none"> • Evaluate error flags. • Check supply voltage of remote modules. • Check CS31 bus line. • Check remote modules.
Slave CPU	*	o	❖	o	CS31 system bus does not work.	<ul style="list-style-type: none"> • Check CS31 bus line. • Check master central unit.

o = LED off, * = LED on, ❖ = LED flashing, ⌘ = LED on or off, gn = green, rd = red

LEDs for user program and error display

LED	RUN	FK1	FK2	FK3	Significance	Remedy
CPU	gn	rd	rd	rd		
Stand-alone CPU, Master-CPU or slave CPU	*	o	o	o	User program is running.	--
	*	o	o	*	User program is running, but a light error occurred.	<ul style="list-style-type: none"> Evaluate error flags and eliminate error.
	o	o	o	o	User program not working.	<ul style="list-style-type: none"> Start user program.
	o	o	o	*	A light error occurred causing user program to be aborted automatically because <ul style="list-style-type: none"> the system constant KW 0,7 is not equal to 0, the "ABORT" block is configured. 	<ul style="list-style-type: none"> Evaluate error flags and eliminate error.
	o	o	*	o	A serious error occurred causing user program to abort automatically.	<ul style="list-style-type: none"> Evaluate error flags and eliminate error, if possible.
	o	*	o	o	A fatal error occurred. User program cannot be started.	<ul style="list-style-type: none"> Evaluate error flags. Power OFF/ON. If unsuccessful, device is defective.
	o	o	*	*	A light and a serious error occurred	<ul style="list-style-type: none"> Evaluate error flags and eliminate error, if possible.
	*	*	*	*	Initialization phase, power on, cold start.	--

O = LED off, * = LED on, ✧ = LED flashing, ✕ = LED on or off, gn = green, rd = red

LEDs for supply voltage and battery

LED	Supply	Battery	Significance	Remedy
CPU	gn	rd		
Stand-alone CPU, master CPU or slave CPU	*	o	Supply voltage available and battery is effective.	--
	*	*	Supply voltage available and battery is not effective.	--
	o	o	Supply voltage is not available.	<ul style="list-style-type: none"> Switch power ON. Check supply voltage.

O = LED off, * = LED on, ✧ = LED flashing, ✕ = LED on or off, gn = green, rd = red

LEDs for overload/short circuit on at least one direct digital output (for 07 KT 92 and 07 KT 93 only)

LED	K	Significance	Remedy
CPU	rd		
Stand-alone CPU, master CPU or slave CPU	*	Overload/short circuit on at least one of the direct outputs A 62,00...07 (A 62,15).	<ul style="list-style-type: none"> Eliminate overload/short circuit..
	o	There is no overload/short circuit.	--

O = LED off, * = LED on, ✧ = LED flashing, ✕ = LED on or off, gn = green, rd = red

A4.4 Troubleshooting on the remote modules

Diagnosis functions for the remote modules

The remote modules are equipped with a number of diagnosis functions. Some of these functions become active only if they have been set by means of the I/O configuration.

Diagnosis, display and messages to central unit	
Diagnosis functions according to module a) always available b) if configured	UE BE OL SC CI CO
Readable on the module by pressing test button ¹⁾ a) Diagnosis messages	UE BE OL SC CI CO
Available for bus master user program, readable on the terminal a) cyclic transmission	- - OL SC CI CO
Module type	
ICSI 08 D1	• • •
ICSI 16 D1	• • •
ICSI 08 E1	• •
ICSI 16 E1	• •
ICSI 08 E4	• •
ICSO 08 R1	• •
ICSO 08 Y1	• • • •
ICSO 16 N1	• • • •
ICSK 20 F1	• •
ICSK 20 N1	• • • •
ICSC 08 L1	• • • • • •
ICSC 16 L1	• • • • • •
ICSF 08 D1	• •
ICDG 32 L1	• • • •
ICSE 08 A6	• •
ICSE 08 B5	• •
ICSA 08 B5	
ICSM 06 A6	
Robot coupler	• •
Festo devices	
07 KR 91	• •
07 KT 92	• • • •
07 KT 93	• • • •
07 KR 31	• •
07 KT 31	• • • •

Key:

- Feature is completely available. Settings and errors can be interrogated from the involved channel.
- (•) Feature is partly available, see module description.
- ¹⁾ For information about the interrogation of settings and diagnosis data, see the module description and chapter A3.3 "Reading I/O configuration and diagnosis data at the module".

BE Bus Error = Bus malfunction, always monitored. The module does not receive a call from the bus master. This may have the following reasons:

- The CS31 system bus line is broken, short-circuited or wired with reversed polarity.
- The central unit has not been set as bus master, see also system constant KW 00,00 in chapter A7.3.

CI Cut Wire of Inputs = Open circuit (monitoring) at inputs, if configured. Each input circuit to be monitored has to be equipped with a resistor of 20...30 kΩ, e.g. in parallel to the signalling contact.

CO Cut Wire of Outputs = Open circuit (monitoring) at outputs, if configured. Each output expects a minimum load of approx. 40 mA when an ON signal is output.

OL Overload (is always monitored).

SC Short circuit (is always monitored).

UE Unit error = internal error (fault) of the module (always monitored in so far as the internal processor can detect this).

Troubleshooting in the remote modules

The LED (3) lights up, if the remote module has detected an error.

The remote module supplies detailed error information via the 8 LEDs (1), if the test button (4) is pressed; see also the module descriptions.

The procedure will be explained in the following for the module ICSC 08 L1 as an example.

After the test button has been pressed for the first time, channel E/A0 (input/output 0) is selected: LED0 flashes. After the button has been released, the diagnosis data of this channel are shown via the yellow LEDs 0 to 7 for approx. 3 seconds.

The LEDs have the following significance:

- 0 Error in the module (UE = Unit error)
- 1 Error on the bus (BE = Bus error)
- 2 not used
- 3 CI/CO = Cut wire of inputs/outputs
- 4 OL = Overload
- 5 SC = Short circuit
- 6 Configuration as output
- 7 Configuration as input

If the LEDs 6 and 7 light up at the same time, the channel is configured as a combined input/output.

The significance of the LEDs (2) is also printed onto the front panel of the module.

The operation is repeated for the other channels each time the test button is pressed and released.

After the last channel E/A7 (input/output 7) has been scanned, pressing the test button again causes a lamp test (LED test) to be performed. All the 8 LEDs should light up. After the button has been released, the LED will show the setting of the DIL switch on the plug-in base for approx. 5 seconds. LED 0 shows the position of switch No. 1 (LEDs 0...7 are assigned to switches No. 1...8).

All the error messages are stored in the module and can only be deleted by pressing the test button for 10 seconds or by power OFF/ON.

A4.5 Acknowledgment of error messages in the remote modules

The remote modules store and display the error messages detected independently of the central unit. The error messages can be acknowledged

- on the remote module by pressing the test button
- in the user program by means of the function block CS31QU (this also deletes the error message stored in the central unit)
- in the terminal mode by means of the command MAIL, see volume 7.3, chapter 3.

If the error has not been eliminated, the error message appears again.

A4.6 Example of an error message

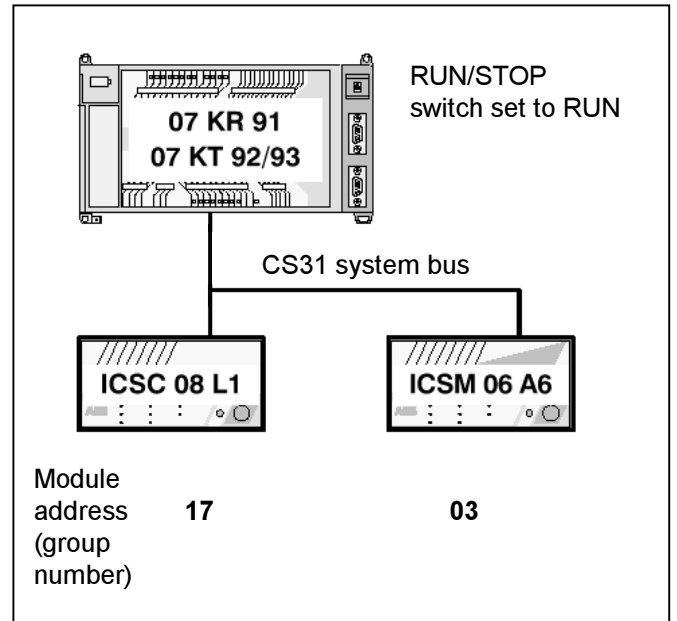

Error which occurred:

The bus line to the remote module having the module address 3 has been broken during operation.

Error flags in the central unit 07 KR 91 / 07 KT 92 / 07 KT 93:

It is assumed that the error flags have been set to 0 by acknowledgment/deletion before the error occurred. In the following, only those error flags are listed whose contents changes.

- M 255,10 = 1 Summation error message
 - M 255,13 = 1 Error class message (FK3 error)
 - MW 255,00 = 15 Error detection: remote module is disconnected
 - MW 255,01 = 05 Module type: analog input and output
 - MW 255,02 = 03 Group number (module address)
 - MW 255,03 = 0
 - MW 255,04 = 0
 - MW 255,05 = 0
 - MW 255,06 = 0
 - MW 255,07 = 0
- Not concerned, as well as all the other error flags which have not been mentioned

LED displays on the bus master central unit 07 KR 91 / 07 KT 92 / 07 KT 93:

- BA lights up ⇒ CS31 bus processor is active. Data communication with remote module having address 17 is continued.
- BE lights up ⇒ Bus Error, error on the CS31 system bus.
- RE lights ⇒ Remote Unit Error, error on a remote module.
- SE off ⇒ Serial Unit Error, CS31 bus interfacing in the central unit works correctly.
- RUN lights up
- FK3 lights up ⇒ light error

Reaction of the bus master central unit 07 KR 91 / 07 KT 92 / 07 KT 93

The processing program and the bus operation continue running (if KW 0,7 = 0).

Reaction of the remote module ICSM 06 A6: All of the outputs turn to 0.

Reaction of the remote module ICSC 08 L1: Data exchange with the bus master central unit 07 KR 91 / 07 KT 92 / 07 KT 93.

Status word EW 07,15 in the central unit 07 KR 91 / 07 KT 92 / 07 KT 93

- Bit 0 = 1 no class 2 error
- Bit 1 = 0 only applicable for 07 KR 91 / 07 KT 92 / 07 KT 93 used as slave
- Bit 2 = 1/0 Date/time of the real-time clock valid / not valid
- Bit 3 = 1/0 Battery effective / not effective
- Bit 4...7 not used
- Bit 8...15 = 2 max. number of modules connected to the CS31 system bus which have been found since the last power-on operation. Will not be altered by the error which has occurred in the meantime.

Acknowledgment of the error flags in the central unit 07 KR 91 / 07 KT 92 / 07 KT 93

Eliminate the error before acknowledgment. Otherwise the error message will appear again.

The bit flags M 255,10 and M 255,13 can be acknowledged by:

- power ON
- program "Start" (on-line in the programming software 907 PC 331)
- cold start (menu item in 907 PC 331)
- setting the RUN/STOP switch to RUN
- overwriting the flag M 255,13 with "0" in the user program
- overwriting the flag M 255,13 with "0" by means of the operating function "Overwrite", see volume 7.3, chapter 3
- using the function block CS31QU in the user program. The block is applicable only for errors which concern the CS31 system bus. It also deletes the error message in the remote module.

The relevant LEDs turn off upon acknowledgment.

The word flags MW 255,00...MW 255,07 can only be deleted by overwriting them. They are overwritten by newly occurring errors.

Acknowledgment of error flags in the remote module ICSM 06 A6

- on the module by holding down the test button
- in the user program of the central unit using the CS31QU block
- in the terminal mode by means of the MAIL command, see volume 7.3, chapter 3.

A4.7 Error flags in the central unit, error classification

The central unit offers error messages for the user program which are classified into 4 error classes (FK1...FK4) according to their severity. The error messages are stored in error flags and can be used in the user program and be read by the programming system.

The following table gives you an overview of the error flags.

Error class	FK1 = fatal error	FK2 = serious error	FK3 = light error	FK4 = warning
General feature of the error class, examples	Safe operation of the operating system is no longer ensured. <u>Error examples:</u> - Checksum error in the operating system EPROM - Write/read error when testing the operating system RAM	The operating system works correctly, but the error-free processing of the user program is not guaranteed. <u>Error examples:</u> - Checksum error in the user program (Flash EPROM) - Write/read error when testing the user RAM	The choice whether the user program has to be aborted by the operating system or not depends on the application. The user decides which reactions are to be initiated. <u>Error examples:</u> - Flash EPROM cannot be programmed - Dual port RAM to the CS31 part (LED SE) is faulty - Remote module has failed (LED RE)	Errors which occur on peripheral devices or which will show their effect only in the future. The user decides which reactions are to be initiated. <u>Error examples:</u> - Short circuit on a remote module
Summation error message ¹⁾	M 255,10			
Error class message (if 1, an error exists)	M 255,11	M 255,12	M 255,13	M 255,14
Error detection (word) ²⁾ Detailed info 1 (word) ²⁾ Detailed info 2 (word) ²⁾ Detailed info 3 (word) ²⁾ Detailed info 4 (word) ²⁾ Detailed info 5 (word) ²⁾ Detailed info 6 (word) ²⁾ Detailed info 7 (word) ²⁾	MW 254,00 MW 254,01 MW 254,02 MW 254,03 MW 254,04 MW 254,05 MW 254,06 MW 254,07	MW 254,08 MW 254,09 MW 254,10 MW 254,11 MW 254,12 MW 254,13 MW 254,14 MW 254,15	MW 255,00 MW 255,01 MW 255,02 MW 255,03 MW 255,04 MW 255,05 MW 255,06 MW 255,07	MW 255,08 MW 255,09 MW 255,10 MW 255,11 MW 255,12 MW 255,13 MW 255,14 MW 255,15
LED displays after initialization	FK1 lights up or LED RUN does not go on, if RUN/STOP switch is set to RUN	FK2 lights up or LED RUN does not go on, if RUN/STOP switch is set to RUN	FK3 lights up. In addition, according to error type: LED BE (Bus Error) LED RE (Remote Unit Error) LED SE (Serial Unit Error)	LED RE (Remote Unit Error) lights up
Reaction when switching on the central unit/ Reaction during operation	All the outputs remain set to 0 or are set to 0. The programming system does not have access. Attention: Both processors of the central unit monitor each other mutually, thus facilitating a powerful diagnosis. If the safety requirements are higher, use specially approved controllers.	All the outputs remain set to 0 or are set to 0. The programming system can get access. The user program is not started or is aborted.	You can choose in case of an error: - Just report the error: Evaluate the error flag M 255,13 - Abort the user program: Set system constant KW 0,7 = 1 (FK3_REAK) or M 255,13 to the function block ABORT	Evaluation of the error messages using the user program
Acknowledgment of the summation error message / of the error class message	- Power ON - Cold start	- Power ON - Cold start	- Power ON / cold start - Set the RUN/STOP switch to RUN - Start the program using 907 PC 331 - Set M 255,13 or M 255,14 to 0 - In case of CS31 error: function block CS31QU	
¹⁾ The summation error flag M 255,10 becomes 1, if at least one of the error class flags is set to 1. If M 255,10 = 0, the central unit has not found any error. The summation error flag is deleted automatically when the error class flags are acknowledged.		²⁾ The central unit enters the last found error into the relevant error flag record for each error class. The entry is made at the end of the program cycle and remains unchanged during the next running program cycle. The word flags can only be acknowledged by overwriting them with "0".		

A4.8 Acknowledgment of error messages in the central unit

Error messages remain stored and will be displayed until they are acknowledged. The following applies:

- The summation error message, the error class messages (bit flags) and the relevant LEDs FK1, FK2 and FK3 are reset with power ON, for example. For other possibilities for resetting/acknowledging them, see chapters A4.5 to A4.8.
- The error identifiers and the detailed information (word flags) have to be reset by means of the user program or by means of the operating function "Overwrite", see volume 7.3, chapter 3. They are also reset when a cold start is performed or by a power-fail, if no back-up battery is effective.

The error message will appear again, if the error has not been eliminated.

A4.9 Additional diagnosis functions

Status word EW 07,15

The following data are continuously updated in the status word EW 07,15:

- Bit 0: This bit is valid for the stand-alone PLC, for the master PLC and for the slave PLC.
Bit 0 = 1: There is no error of class 2.
Bit 0 = 0: There is an error of class 2.
- Bit 1: This bit is valid only for the slave PLC.
Bit 1 = 1: The slave PLC is adopted into the bus cycle of the master PLC.
Bit 1 = 0: The slave PLC is *not* adopted into the bus cycle of the master PLC.

- Bit 2: This bit is valid for the stand-alone PLC, for the master PLC and for the slave PLC.
Bit 2 = 1: Date and time of the real-time clock *are valid*.
Bit 2 = 0: Date and time of the real-time clock are *not valid*.
- Bit 3: This bit is valid for the stand-alone PLC, for the master PLC and for the slave PLC.
Bit 3 = 1: Battery is *effective*.
Bit 3 = 0: Battery is *not effective*.
- Bits 4..7 are not used
- Bits 8..15: *Maximum* number of remote modules which have been existing in the CS31 bus cycle of the master PLC since the last power-ON or since the last cold start. Their number may be larger than the number of the remote modules which are *currently* existing in the CS31 bus cycle.

A4.10 Meaning of the contents of the error word flags

Explanation of the following table:

- Address = Memory address at which the error was detected.
- Group number = Module address of the remote module
- Channel number = Number of the faulty channel
- Module type Meaning
000 Digital input
001 Analog input
002 Digital output
003 Analog output
004 Digital input/output
005 Analog input/output
255 Bus master or slave central unit in which the error has occurred and is stored.

Error class	Error description	Error identifier in MW 254,00		Detailed info 1 in MW 254,01	Detailed info 2 in MW 254,02	Detailed info 3 in MW 254,03	Further detailed info in MW 254,04 : MW 254,07
		Dec	Hex				
FK1 Fatal error	Checksum error of the system EPROM	1 _D	1 _H	–	–	–	–
	Operating system of the central unit is defective, or a defective RAM is detected when a cold start is performed (complete RAM test)	2 _D	2 _H	Address	–	–	–

Error class	Error description	Error identifier in MW 254,08		Detailed info 1 in MW 254,09	Detailed info 2 in MW 254,10	Detailed info 3 in MW 254,11	Further detailed info in MW 254,12 : MW 254,15
		Dec	Hex				
FK2 Serious error	RAM defective (user program or operand memory)	128 _D	80 _H	Address	–	–	–
	Illegal master/slave identifier	129 _D	81 _H	–	–	–	–
	A serious error has occurred when the CS31 bus interfacing was initialized. The CS31 bus processor does not give any response to the PLC side within the specified time.	130 _D	82 _H	–	–	–	–
	PLC is overloaded, cycle time is too short.	131 _D	83 _H	–	–	–	–
	An error which cannot specified in detail is detected by the operating system during the execution time.	132 _D	84 _H	–	–	–	–
	Checksum error in the Flash EPROM	133 _D	85 _H	–	–	–	–
	CS31 bus processor does not send an OK response to the PLC after a cold start command issued by the PLC.	134 _D	86 _H	–	–	–	–
	Error detection not used at the moment.	135 _D	87 _H	–	–	–	–
	CS31 bus processor reports an error via EW 07,15 bit 0. This bit is checked before each start of the PLC program.	136 _D	88 _H	–	–	–	–
	An illegal value has been configured (KW 00,10 or KW 00,11) for specifying the size of the I/O area between the master PLC and the slave PLC.	137 _D	89 _H	–	–	–	–
	More timers than available in the PLC were required during the execution time.	257 _D	101 _H	–	–	–	–
	An unknown operator/block is detected in the user program during the execution time.	258 _D	102 _H	–	–	–	–
	The CS31 bus processor does not work correctly. Therefore it does not authorize the operating processor to access the dual-port RAM.	259 _D	103 _H	–	–	–	–

Error class	Error description	Error identifier in MW 255,00		Detailed info 1 in MW 255,01	Detailed info 2 in MW 255,02	Detailed info 3 in MW 255,03	Further detailed info in MW 255,04 : MW 254,07
		Dec	Hex				
FK3 Light error	Remote module disconnected	15 _D	F _H	Module type	Group number	–	–
	CS31 bus error (there is no remote module on the bus) Note: If there are only analog modules connected to the CS31 system bus, this error message may occur when the supply voltage is switched on although the analog modules have been correctly adopted into the CS31 bus cycle after a certain time. Reason: The analog modules have a long initialization time. After this time is over, they only now appear at the CS31 bus as remote modules. During the initialization time the master PLC cannot recognize them.	16 _D	10 _H	–	–	–	–
	The Flash EPROM is not programmable.	128 _D	80 _H	Address of defective memory cell	–	–	–
	The Flash EPROM cannot be deleted.	129 _D	81 _H	Address of the memory cell which cannot be deleted	–	–	–
	The PLC application mode configured in the system constant KW 00,00 has not been activated yet. Please perform activation (see also system constant KW 00,00).	130 _D	82 _H	Value of KW 00,00 activated last	Value of KW 00,00 not yet activated	–	–
	CRC error in Flash EPROM	131 _D	83 _H	Address of the block with CRC error	Segment address of the block with CRC error	–	–

Error class	Error description	Error identifier in MW 255,08		Detailed info 1 in MW 255,09	Detailed info 2 in MW 255,10	Detailed info 3 in MW 255,11	Further detailed info in MW 255,12 : MW 254,15
		Dec	Hex				
FK4 Warning	Internal error of a remote module	1 _D	1 _H	Module type	Group number	Channel number	–
	Cut wire (open circuit)	2 _D	2 _H	Module type	Group number	Channel number	–
	Wrong level of an analog output	3 _D	3 _H	Module type	Group number	Channel number	–
	Overload	4 _D	4 _H	Module type	Group number	Channel number	–
	Overload + cut wire	6 _D	6 _H	Module type	Group number	Channel number	–
	Short circuit	8 _D	8 _H	Module type	Group number	Channel number	–
	Short circuit + cut wire	10 _D	A _H	Module type	Group number	Channel number	–
	Overload + short circuit	12 _D	C _H	Module type	Group number	Channel number	–
	Short circuit + overload + cut wire	14 _D	E _H	Module type	Group number	Channel number	–
	There is no user program available when the system is started.	128 _D	80 _H	–	–	–	–
	During start-up, the system detects that the program end is missing	129 _D	81 _H	–	–	–	–
	During start-up, the system detects that the number of block parameters has not been specified correctly for a certain block.	130 _D	82 _H	Program address of the block	Program address of the faulty block parameter	–	–
	During start-up, the system detects a syntax error in the user program.	131 _D	83 _H	Program address	–	–	–
	During start-up, the system detects that the historical value memory is too small.	132 _D	84 _H	–	–	–	–
	During start-up, the system detects that no cycle time has been set.	133 _D	85 _H	–	–	–	–
	During start-up, the system detects that there are bracketing errors in the user program.	134 _D	86 _H	Program address	–	–	–
	During start-up, the system detects that the target label for a conditional jump is missing.	135 _D	87 _H	Program address	–	–	–

Error class	Error description	Error identifier in MW 255,08		Detailed info 1 in MW 255,09	Detailed info 2 in MW 255,10	Detailed info 3 in MW 255,11	Further detailed info in MW 255,12 : MW 254,15
		Dec	Hex				
FK4 Warnung	Internal error (non-maskable internal interrupt has occurred)	136 _D	88 _H	–	–	–	–
	Internal error (an inhibited interrupt has occurred)	137 _D	89 _H	–	–	–	–
	The PLC program is not started because the number of remote modules which are adopted into the CS31 bus cycle is smaller than the number configured in KW 00,09.	138 _D	8A _H	Configured number of remote modules (KW 00,09)	Actual number of modules connected to the CS31 bus cycle	–	–
	The PLC does not access the process inputs and outputs yet because the number of remote modules which are adopted into the CS31 bus cycle is smaller than the number configured in KW 00,09.	139 _D	8B _H	Configured number of remote modules (KW 00,09)	Actual number of modules connected to the CS31 bus cycle	–	–

A4.11 Reaction on bus master central unit and remote modules in case of errors

No.	Error	Display/reaction of the bus master central unit	Display/reaction of input/output remote modules	Display/reaction of the slave central units
1	Bus master central unit has failed, e.g. because of power failure	No display, all outputs are off.	LED (3) lights up. All outputs are turned to 0.	07 KR 91 / 07 KT 9x: - LED BA is on - LED RE flashes - Bit 1 = 0 in the status word EW 07,15
2	Bus master function of the central unit (Serial Unit) has failed, e.g. the bus processor is defective	Displays: FK2 = Serious error RE = Remote Unit Error SE = Serial Unit Error Flags: M 255,10 = 1 M 255,12 = 1 for further flags see A4.7		07 KR 31 / 07 KT 31: - Error LED flashes - Bit 1 = 0 in the status word EW 07,15
3a	CS31 system bus is disconnected (all the remote modules are disconnected)	Displays: FK3 = Light error BE = Bus Error RE = Remote Unit Error SE = Serial Unit Error		
3b	CS31 system bus is short-circuited	Flags: M 255,10 = 1 M 255,13 = 1 for further flags see A4.7		
4a	CS31 system bus is disconnected (some of the remote modules are disconnected)	Displays: FK3 = Light error BE = Bus Error SE = Serial Unit Error	Remote modules without connection to the bus master central unit: same as 1	Slave central units without connection to the bus master central unit: same as 1
4b		Flags: M 255,10 = 1 M 255,13 = 1 for further flags see A4.7	Remote modules with connection to the bus master central unit: no display/reaction	Slave central units with connection to the bus master central unit: no display/reaction
5a	A remote module has been lost on the CS31 system bus. Cause:	Displays: Remote Unit Error Flags: M 255,10 = 1 M 255,13 = 1 for further flags see A4.7	Remote modules with connection to the bus master central unit: no display/reaction	Slave central units with connection to the bus master central unit: no display/reaction
5b	No connection to the CS31 system bus		Remote modules without connection to the bus master central unit: same as 1	Slave central unit without connection to the bus master central unit: same as 1
5c	Defective remote module		not clear	Error class FK1 / FK2, all outputs turn to 0.
5d	Power failure		all outputs turned to 0	all outputs turned to 0
6a	An error has occurred at the inputs or outputs of a remote module, e.g. a short circuit.	same as 5	Remote module affected: LED (3) lights up. The LEDs (1) supply detailed info by means of the test button (4).	07 KT 9x affected: LED K = Short circuit 07 KT 31: Error LED is ON Flags (07 KT 9x, KT 31): M 255,10 = 1 M 255,14 = 1 for further flags see A4.7
6b			Remote modules not affected: no display/reaction	Slave central units not affected: no display/reaction

Reaction on bus master central unit and remote modules in case of errors (continued)

No.	Error	Display/reaction of the bus master central unit	Display/reaction of input/output remote modules	Display/reaction of the slave central units
7a	Two remote input modules of the same type have been set to the same address.	The error is detected only when the signal statuses of the two modules become different. The message is faulty in this case, and the modules are considered to be disconnected. Display: RE = Remote Unit Error Flags: M 255,10 = 1 M 255,13 = 1 for further flags see A4.7 / A4.10	Modules affected: same as 1 Other modules: no display/reaction	same as 1
7b	Two remote modules of the same type have been set to the same address.	No reaction unless there is a large distance between the remote modules.	Faultless operation of the two modules, unless they are far apart from each other.	Not applicable because inputs and outputs are always present.
7c	Two remote modules of different types, but with overlapping ranges, have been set to the same address, e.g., ICSI 16 D1 and ICSK 20 F1.	The error has been already detected during the initialization. The two remote modules are not included in the bus cycle.	Modules affected: same as 1	Modules affected: same as 1
			Other modules: no display/reaction	Other modules: no display/reaction
7d	Address 62 or 63 has been set to a digital remote module.	Is not detected.	<ul style="list-style-type: none"> – Output of the signals in parallel to the bus master – Input signals are ignored. 	–
7e	An address higher than 5 has been set to an analog remote module.	Is not detected.	same as 1	–

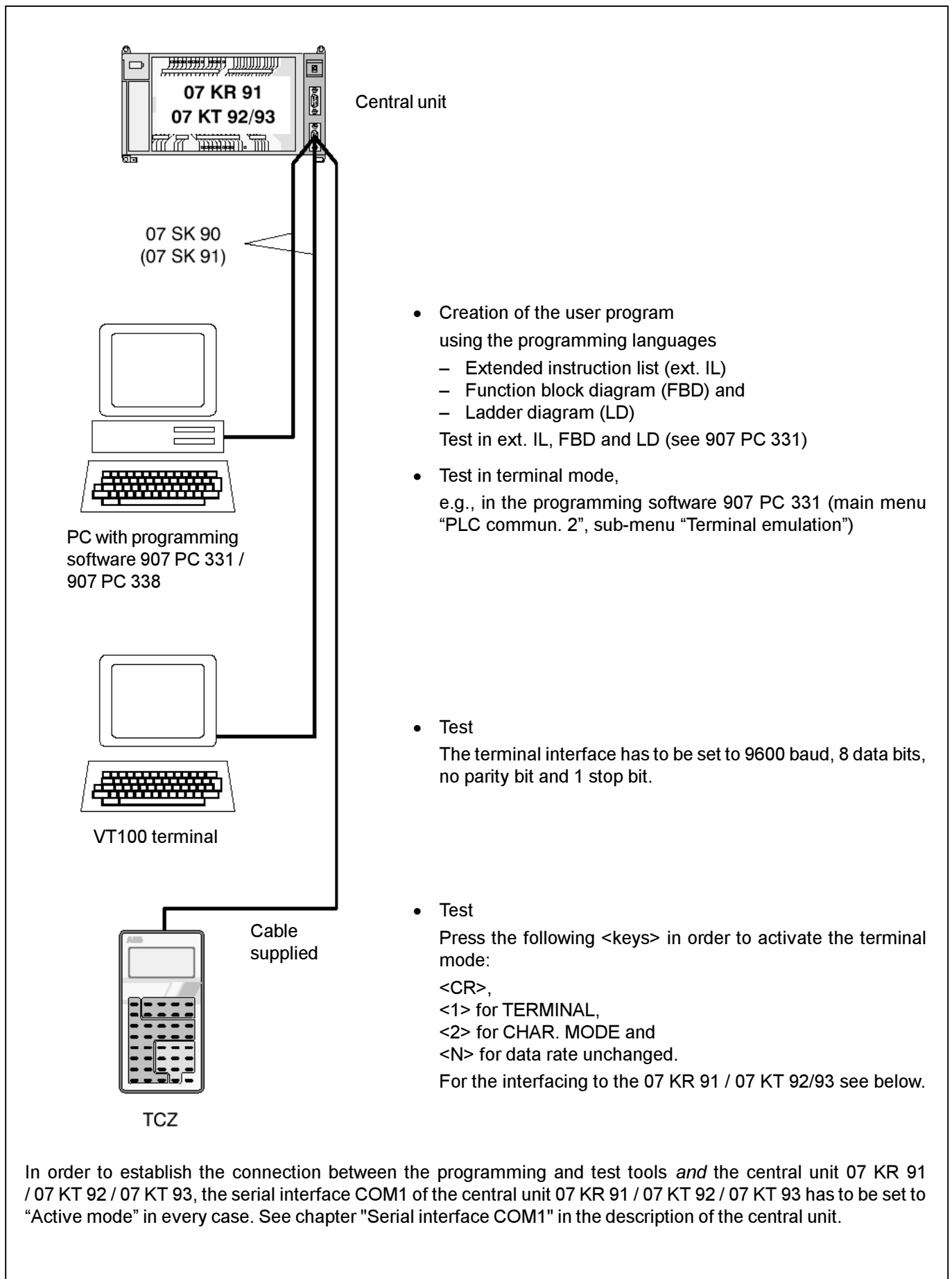

A6 Man-machine communication (MMC)

see system description Advant Controller 31, volume 6
(Order No. 1SAC131699R0101).

A7 Operands of 07 KR 91, 07 KT 92 and 07 KT 93 (variables and constants) (valid for 07 KR 91 (all types), 07 KT 92 R202/262, 07 KT 93 R101/171 and 07 KT 93-S R2171)

A7.1 Freely available variables and constants

Inputs

E 00,00...E 61,15	:	Digital inputs, CS31 remote modules
E 62,00...E 63,03	:	Digital inputs of the central unit 07 KR 91
E 62,00...E 62,11	:	Digital inputs of the central unit 07 KT 92
E 62,00...E 63,07	:	Digital inputs of the central unit 07 KT 93
E 63,14 and E 63,15	:	High-speed digital inputs ($T_D = 8 \mu s$), signals are identical to E 62,00 and E 62,01
E 63,13	:	High-speed counter, interrogation of "Zero crossing"
EW 00,00...EW 05,15	:	Analog inputs, CS31 remote modules
EW 06,00...EW 06,03	:	Analog inputs of the central unit 07 KT 92
EW 06,15	:	High-speed counter, interrogation of the counter content
EW 07,00...EW 07,07	:	reserved
EW 07,08...EW 07,14	:	Reading of the real-time clock
EW 07,15	:	Status for CS31 system bus, clock, battery

Outputs

A 00,00...A 61,15	:	Digital outputs, CS31 remote modules
A 62,00...A 62,11	:	Digital outputs of the central unit 07 KR 91
A 62,00...A 62,07	:	Digital outputs of the central unit 07 KT 92
A 62,00...A 62,15	:	Digital outputs of the central unit 07 KT 93
A 62,00	:	High-speed counter, direct output of "Counter zero crossing" after activation
A 63,13...A 63,15	:	High-speed counter, enabling, activation of E 62,01 and A 62,00, adoption of start value
AW 00,00...AW 05,15	:	Analog outputs, CS31 remote modules
AW 06,00...AW 06,01	:	Analog outputs of the central unit 07 KT 92 (-10V...+10V)
AW 06,15	:	High-speed counter, "Start value"

Internal operands

M 00,00...M 255,09	:	Binary flags
S 00,00...S 127,15	:	Steps
K 00,00...K 00,01	:	Binary constants
MW 00,00...MW 253,15	:	Word flags
KW 01,00...KW 39,15	:	Word constants
MD 00,00...MD 31,15	:	Double word flags
KD 00,01...KD 07,15	:	Double word constants

Time values for time functions

KD yy,xx	:	Time values for time functions such as ESV, ASV etc. are configured as <i>double word constants</i> or as
MD yy,xx	:	double word flags. Only integral multiples of 5 ms are permitted.

A7.2 System constants / diagnosis flags / CS31 status (overview)

Setting the operating modes

The constants KW 00,00...KW 00,15 are reserved as system constants. Even the constants KW 00,13...KW 00,15, although not yet used, may *under no circumstances* be used for other purposes.

KW 00,00	:	Setting the PLC operating modes, (Stand-alone PLC, Master PLC, Slave PLC)
KW 00,01	:	Initialization: bit flag area
KW 00,02	:	Initialization: word flag area
KW 00,03	:	Initialization: double word flag area
KW 00,04	:	Initialization: step chain flag area
KW 00,05	:	Initialization: historical values
KW 00,06	:	Application modes of the serial interface COM 1
KW 00,07	:	PLC reaction to class 3 errors

- KW 00,08 : PLC reaction to an overload/short-circuit at the transistor outputs A 62,00...A 62,07 (A 62,15) (07 KT 92 and 07 KT 93 only)
- KW 00,09 : Initialization of the CS31 system after power ON, warm start or cold start
- KW 00,10 : Size of the transmitting area of the slave PLC
- KW 00,11 : Size of the receiving area of the slave PLC
- KW 00,12 : Automatic warm start after an FK2 error

Setting the cycle time

- KD 00,00 : The cycle time of the PLC program is preset with this constant. The cycle time is given in units of measurement milliseconds. Only integral multiples of 5 ms are permitted.

Error diagnosis

- Summation error display : M 255,10 indicates, that the PLC has detected an error
- Fatal error, FK1 : M 255,11 = 1 i.e. error detected, detailed information in MW 254,00...MW 254,07
- Serious error, FK2 : M 255,12 = 1 i.e. error detected, detailed information in MW 254,08...MW 254,15
- Light error, FK3 : M 255,13 = 1 i.e. error detected, detailed information in MW 255,00...MW 255,07
- Warning, FK4 : M 255,14 = 1 i.e. error detected, detailed information in MW 255,08...MW 255,15

First-cycle detection

M 255,15

This binary flag can be used for detection of the first program cycle after a program start. It is always set to "zero" after each program start, independent of the initialization instructions given by the system constants. If this flag is read by the user program and then set to "1", it can be found out whether or not the user program was started once more.

CS31 status word

EW 07,15

- Bit 0 = 1 : No CS31 class 2 error present.
- Bit 1 = 1 : PLC has been adopted into the CS31 bus cycle (only relevant if used as a slave).
- Bit 2 = 1 : Time and date are valid.
- Bit 3 = 1 : Battery is effective.
- Bit 4...7 : Not used.
- Bit 8..15 : Maximum number of modules on the CS31 system bus, found out until now (only relevant if used as a master).

A7.3 System constants / Setting of operating modes

• Definitions

Cold start

- All of the RAM memories are tested and deleted.
- If there is no user program in the Flash EPROM, the default values are set to all of the system constants (identical to the factory settings).
- If there is a user program in the Flash EPROM, this program is loaded into the RAM including the system constants.
- The operating modes given by the system constants are set.
- The CS31 system bus is initialized again (only when used as a master on the CS31 system bus).

Performing a cold start

- Power OFF/ON, if there is no backup battery or
- Command KALT <CR> in terminal mode (see volume 7.3) or
- Menu item "Cold start" in the programming system

Warm start

- All of the RAM memories, with the exception of the program memory and the operand memory (flags), are tested and deleted.
- If there is a user program in the Flash EPROM, this program is loaded into the RAM including the system constants.
- The operating modes given by the system constants are set.
- The CS31 system bus is initialized again (only when used as a master on the CS31 system bus).

Performing a warm start

- Power OFF/ON, if there is a backup battery or
- Command WARM <CR> in terminal mode (see volume 7.3) or
- Menu item "Release PLC mode" in the programming system

Operating mode:

Master PLC, Slave PLC or Stand-alone PLC

- Absolute identifier: KW 00,00
- Symbolic identifier: MAST_SLV
- Meaning of the value of the constant:
 - Master PLC at CS31 system bus -1 (FFFF_H)
 - Stand-alone PLC -2 (FFFE_H)
 - Slave PLC at the CS 31 system bus module address CS31 module addresses 0...61
- Range of values: -2, -1, 0...61
- Default value: -2 (Stand-alone PLC)

Important!

The change of the PLC operation mode is carried out in three steps:

1. Change system constant KW 00,00 in the PLC
2. Save PLC program in the Flash EPROM
3. Activate new PLC operating mode with the following steps:
 - Call menu item "Release PLC mode" in the ABB programming and test system or
 - perform a warm start or
 - perform a cold start.

Back-up of data areas

Back-up (buffering) of data areas, i.e. saving of data during power OFF/ON, is only feasible with built-in battery. The following data can be buffered, completely or partly:

- Binary flags
- Word flags
- Double word flags
- Step chains
- Historical values

In order to back-up certain data, they have to be excluded from initialization to 0.

Initialization of data areas

During program start, that data areas are initialized to 0 partly or completely, that are defined by system constants. The initialization works as shown in the following table.

If no battery is effective or if the system constants are in their default values (factory settings), all of the above mentioned data areas are completely set to 0 after power OFF/ON.

Conditions, --> Action	Flags, step chains, and historical values which are initialized (set to 0)	
NO battery available, --> Power ON	all	
Menu item --> Abort --> Cold start	all	
Battery effective, RUN/STOP switch on RUN, --> Power ON	according to the values of the system constants (see below)	
RUN/STOP switch, --> RUN		
Menu item --> Abort --> Start		

Initialization: Binary flags

- Absolute identifier: KW 00,01
- Symbolic identifier: INIT_M

Value n of the system constant KW 00,01	Binary flag areas initialized (set to 0)
n = 0 (default)	M 000,00...M 255,15
n = 1...255	M n,00...M 255,15
n < 0, n > 255	M 255,10...M 255,15

- Example: KW 00,01 = 52
 Initialized is: M 52,00...M 255,15
 Buffered is: M 00,00...M 51,15
 Precondition: Battery is available

Initialization: Word flags

- Absolute identifier: KW 00,02
- Symbolic identifier: INIT_MW

Value n of the system constant KW 00,02	Word flag areas initialized (set to 0)
n = 0 (default)	MW 000,00...M 253,15
n = 1...253	MW n,00...M 253,15
n < 0, n > 253	no initialization

Initialization: Double word flags

- Absolute identifier: KW 00,03
- Symbolic identifier: INIT_MD

Value n of the system constant KW 00,03	Double word flag areas which are initialized (set to 0)
n = 0 (default)	MD 00,00...MD 31,15
n = 1...31	MD n,00...MD 31,15
n < 0, n > 31	no initialization

Initialization: Step chains

- Absolute identifier: KW 00,04
- Symbolic identifier: INIT_S

Value n of the system constant KW 00,04	Step chain areas initialized (set to 0)
n = 0 (default)	S 000,00...S 127,15
n = 1...127	S n,00...S 127,15
n < 0, n > 127	no initialization

Initialization: Historical values

- Absolute identifier: KW 00,05
- Symbolic identifier: INIT_VW

Value n of the system constant KW 00,05	Historical values initialized (set to 0)
n = 0 (default)	Initialization of all historical values
n < 0, n > 0	no initialization

Application mode: Serial interface COM1

- Absolute identifier: KW 00,06
- Symbolic identifier: MODE_SST
- Default value: 0

Table: Conditions for the settings of the operating modes of the COM1 interface

RUN/STOP-switch	System constant KW 00,06	System cable/device	Mode set by this
STOP	x	x	Active
RUN	1	x	Active
	2	x	Passive
	0, <0, >2	07 SK 90	Active
07 SK 91, TCZ		Passive	

x: without effect

- A change of this system constant becomes effective:
 - immediately

PLC reaction to class 3 errors

- Absolute identifier: KW 00,07
- Symbolic identifier: FK3_REAK
- Meaning of the value of the constant:
 - Just output error: 0
 - Output error and abort PLC program: <0, >0
- Range of values: <0, =0, >0
- Default value: 0
- i.e. just output error

- A change of this system constant becomes effective:
 - immediately

PLC reaction to the occurrence of an overload/short circuit at the direct outputs A 62,00...A 62,07 (A 62,15) (07 KT 92 and 07 KT 93 only)

- Absolute identifier: KW 00,08
- Symbolic identifier: ÜLAST_REAK
- Meaning of the value of the constant:

Overloaded output is switched on again automatically: 0

Overloaded output is *not* switched on again automatically: 1

If another value than 0 or 1 is given, the PLC selects the standard setting "automatic reclosing"

- Range of values: 0, 1
- Default value: 0
i.e. the overloaded output is switched on again automatically by the PLC.

Important!

The change of the PLC reaction on an overload/short-circuit is carried out in three steps:

1. Change system constant KW 00,08 in the PLC
2. Save PLC program in Flash EPROM
3. Activate new PLC operating mode with the following steps:
 - perform a warm start or
 - perform a cold start.

• Initialization of the CS31 system after power ON, warm start or cold start

- Absolute identifier: KW 00,09
- Symbolic identifier: HOCHFABR
- This system constant is only effective if the central unit is configured as a bus master.
- Meaning of the value of the constant:

The user program is started.
The central unit takes no notice of initialization of the CS31 remote modules and their adoption into the CS31 bus cycle: = 0

The user program is not started until at least n remote modules have been initialized and adopted into the CS31 bus cycle: = +n

The user program is started. It does not handle the process inputs and outputs until at least n remote modules have been initialized and adopted into the CS31 bus cycle. However, the CS31 status information in EW 07,15 is available as early as with the program start. This is also valid for the dual port RAM image of the two high-speed inputs at terminals 02 and 03: = -n

 - Range of values: -31...+31
 - Default value: 0
i.e. the user program is started immediately.

A change of this system constant becomes effective:

- with the next warm start or
- with the next cold start.

• Size of the transmitting area of the slave PLC

- Absolute identifier: KW 00,10
- Symbolic identifier: SLV_SEND
- Meaning of the value of the constant:

The slave PLC can be used at the CS31 system bus either in the binary area or in the word area. The binary values are transferred byte by byte. It is possible to set the number of bytes (or words) which are to be sent from the slave PLC to the master PLC.

 - For use in the binary area:

Transmitting: 0...15 bytes	0...15
----------------------------	--------
 - For use in the word area:

Transmitting: 0...8 words	100...108
---------------------------	-----------
 - Default value: 0
 - Range of values: 0...15 and 100...108

A change of this system constant becomes effective:

- with the next warm start or
- with the next cold start.

Note:

The default setting in the binary area is:

- transmit 4 bytes and
- receive 4 bytes.

This is defined by the default combination KW 00,10 = KW 00,11 = 0.

The configured combination KW 00,10 = KW 00,11 = 4 has the same result as the default combination.

The combination KW 00,10 = KW 00,11 = 100

is inadmissible! It would mean:

Transmit 0 words and receive 0 words.

When employed in the word area, the unused upper 8 channels of the address can be used by an analog module (no KR/KT).

• Size of the receiving area of the slave PLC

- Absolute identifier: KW 00,11
- Symbolic identifier: SLV_REC
- Meaning of the value of the constants:

The slave PLC can be used at the CS31 system bus either in the binary area or in the word area. It is possible to set the number of bytes (or words) which are to be received by the slave PLC from the master PLC.

 - For use in the binary area:

Receiving: 0...15 bytes	0...15
-------------------------	--------
 - For use in the word area:

Receiving: 0...8 words	100...108
------------------------	-----------

- Default value: 0
- Range of values: 0...15 and 100...108

A change of this system constant becomes effective:

- with the next warm start or
- with the next cold start.

Note:

The default setting in the binary area is:

- transmit 4 bytes and
- receive 4 bytes.

This is defined by the default combination
KW 00,10 = KW 00,11 = 0.

The configured combination

KW 00,10 = KW 00,11 = 4

has the same result as the default combination.

The combination

KW 00,10 = KW 00,11 = 100

is inadmissible! It would mean:

Transmit 0 words and receive 0 words.

When employed in the word area, the unused upper 8 channels of the address can be used by an analog module (no KR/KT).

• **Automatic warm start after an FK2 error**
(only for 07 KT 92)

- Absolute identifier: KW 00,12
- Symbolic identifier: SYSTEM
- By means of the system constant KW 00,12 an automatic warm start can be configured after an FK2 error:

Bit 0 of KW 00,12 = 0: no automatic warm start

Bit 0 of KW 00,12 = 1: automatic warm start

The bits 1...15 of KW 00,12 must be 0.

In the default setting KW 00,12 = 0 the module 07 KT 92 **R202/262** has the same behaviour as the module **R101** (no warm start after an FK2 error).

A change of this system constant becomes effective:

- with the next warm start.

• **PLC cycle time**

- Absolute identifier: KD 00,00
- Symbolic identifier: ZYKL_ZEIT
- Meaning of the value of the constants:

The PLC program is processed cyclically in the time intervals stated by the set cycle time. The entries are made in the unit of measurement [ms]. The smallest cycle time that can be entered is 5 ms. Only integral multiples of 5 ms are permissible.

- Range of values: ≥ 5
- Default value: 10

A change of this system constant becomes effective:

- with the next program start.

A8 The ARCNET system (Attached Resource Computer Network)

- ARCNET is a system for data transmission in local networks
- The ARCNET protocol is based on the Token Passing principle.
- By passing an identifier (token) from station to station, it is guaranteed that only one station can start a data transmission (transmission without collisions).
- The order of sequence in which the stations are accessed is automatically adapted by the existing conditions in the network. The network is reconfigured automatically each time a station is added to the network or switched off.

A8.1 The networking configurations

Linear ARCNET

- In the Linear ARCNET configuration, the stations are connected to one another directly, i.e. without using any distribution units.
- Each station is inserted into the network by using a T connector.
- Both cable ends must be terminated by terminating resistors.
- A maximum of 8 stations can be connected to one linear ARCNET.
- The maximum length of the network is 300 m.
- An additional segment can be connected at the end of the wired segment via an Active Hub (active distribution unit), see next page.

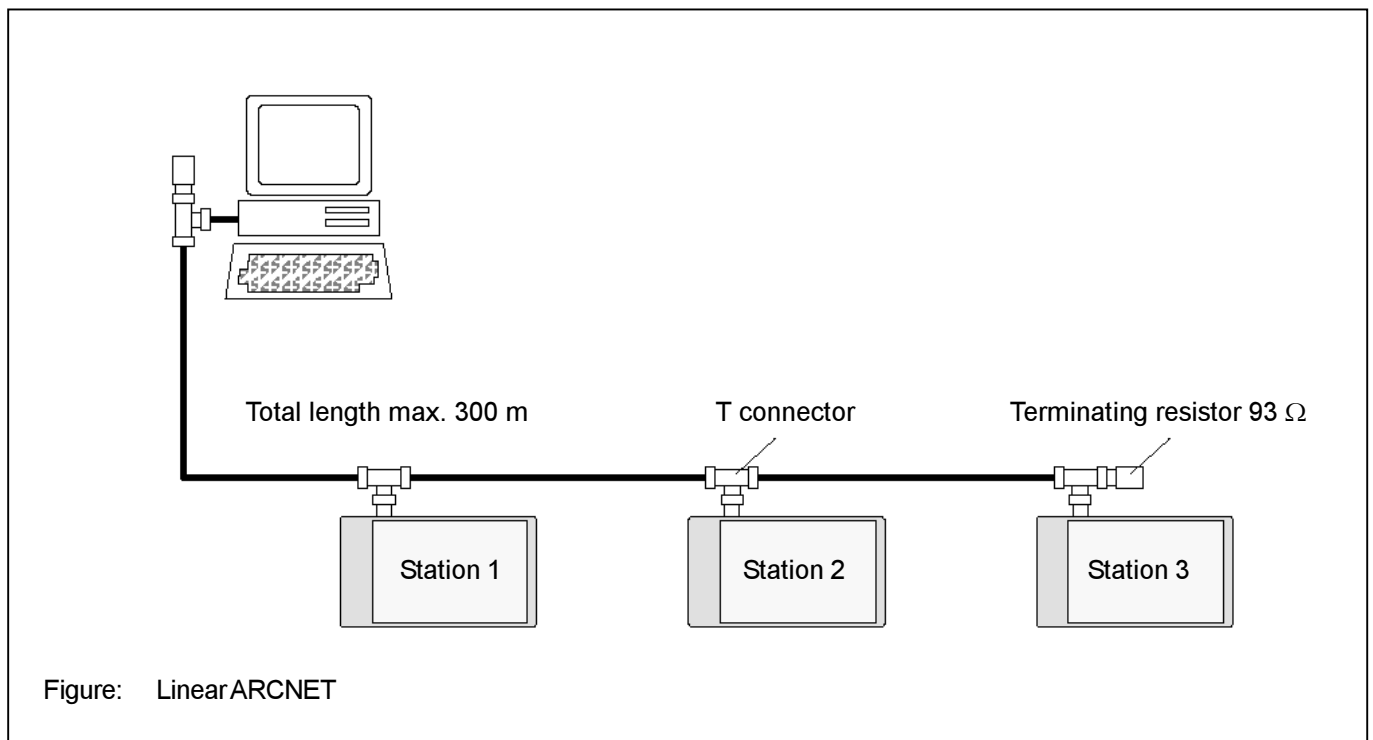

Linear ARCNET, expanded by active distribution units (Active Hubs)

- Active Hubs amplify arriving signals. They thus stabilize the network configuration and allow especially long distances. The Active Hub decouples station connectors from each other, ensuring that the entire network does not fail if one of the connections fails.
- The maximum length of the network is 6 km.
- A maximum of 255 stations can be used.

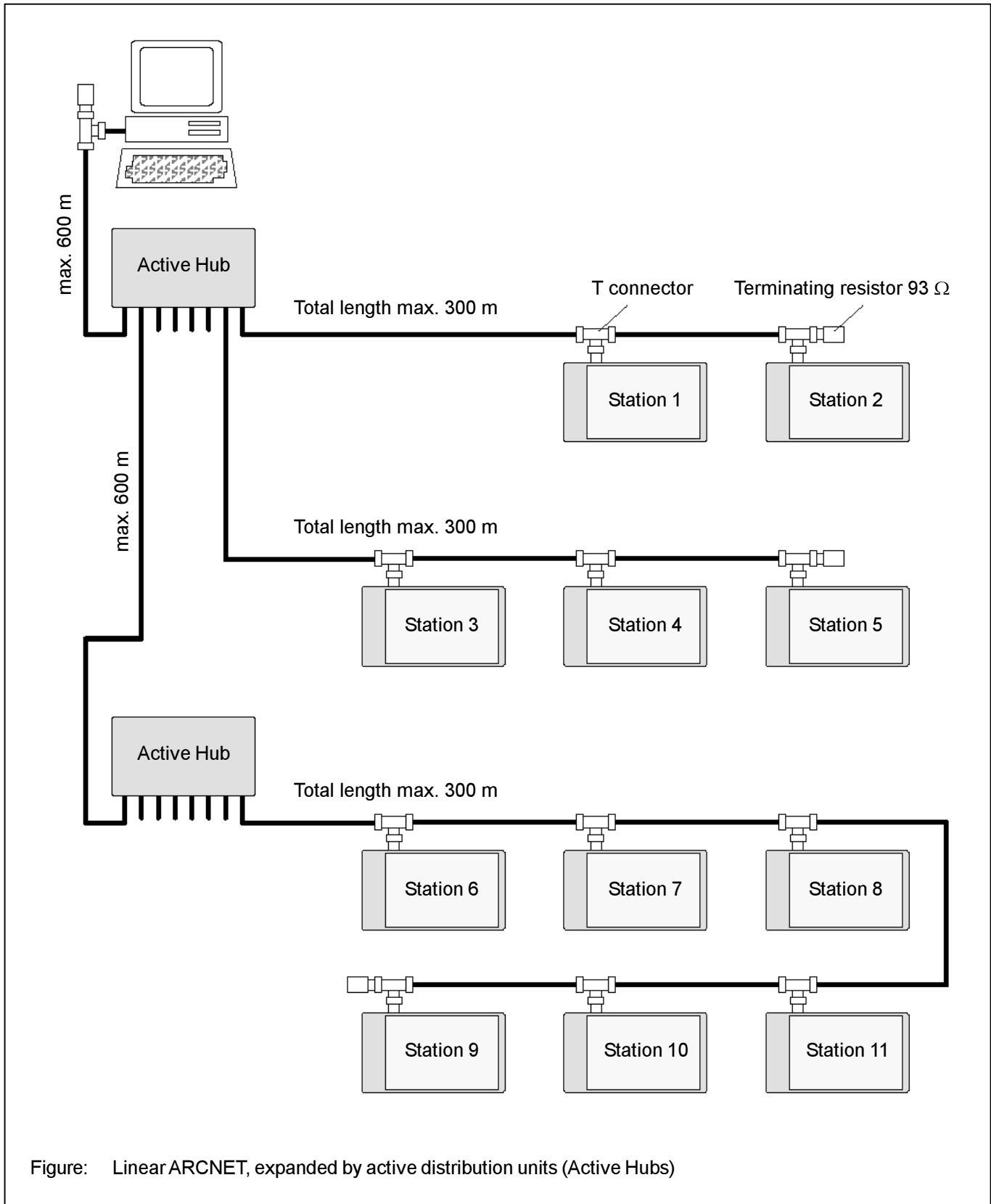

Figure: Linear ARCNET, expanded by active distribution units (Active Hubs)

A8.2 The features of the ARCNET system

- Data transmission rate 2.5 MBit/s
- Coaxial cable of type RG62/U, 93 Ω
- Coaxial plugs, suitable for the coaxial cable
- Maximum number of stations: 255

Maximum distances

- The maximum distance between two stations amounts to 6 km.
- The maximum distance between an Active Hub and an ARCNET station or between two Active Hubs amounts to 600 m.
- The maximum distance between a Passive Hub and an ARCNET station or between an Active Hub and a Passive Hub is 30 m. A Passive Hub works like a resistor network which carries out the cable termination at the stations.
- The maximum distance within a Linear ARCNET is 300 m. A maximum of 8 stations can be connected.

10 Interface Cables

Interface cables for connection between peripheral units and the 9-pole serial interfaces of the basic units 07 KR 91, 07 KT 92, 07 KT 93, 07 KT 93-S and 07 KT 94 (AC31, AC31-S) and the communication processors 07 KT 62 and 07 KP 64 (ABB Procontic T200):

Type	Order number
07 SK 90 R1	GJR5 2502 00 R0001
07 SK 91 R1	GJR5 2503 00 R0001
07 SK 92 R1	GJR5 2504 00 R0001

10.1 Interface Cables 07 SK 90 R1, 07 SK 91 R1 and 07 SK 92 R1

for connection of peripheral units to the 9-pole serial interfaces of the basic units 07 KR 91, 07 KT 92, 07 KT 93, 07 KT 93-S and 07 KT 94 (AC31, AC31-S) and the communication processors 07 KP 62 and 07 KP 64 (ABB Procontic T200) and 07 KP 90 (AC31)

10.1.1 Survey table

The following table shows, which interface cables can be used for connections between peripheral units and the 9-pole interfaces of the AC31/AC31-S basic units and the T200 communication processors.

Connection from the processor unit interface	via the system cable (interface cable)	to the peripheral unit
07 KR 91 COM1 07 KT 9x COM1 07 KP 62 COM1	07 SK 90	PC programming unit with 907 PC 331
07 KR 91 COM1 07 KT 9x COM1 07 KP 62 COM1	07 SK 90	Operating station in active mode
07 KR 91 COM1 07 KT 9x COM1 07 KP 62 COM1 07 KP 64 CONSOLE 07 KP 90 CONSOLE	07 SK 90	Terminal
07 KR 91 COM1 07 KT 9x COM1 07 KT 9x COM2 07 KP 62 COM1 07 KP 62 COM2	07 SK 91	Operating station in passive mode
07 KR 91 COM1 07 KT 9x COM1 07 KT 9x COM2 07 KP 62 COM1 07 KP 62 COM2 07 KP 64 RCOM 07 KP 90 RCOM	07 SK 92	Modem with a standard interface, for signal names and pin assignment see chapter 10.4

10.2 Interface Cable 07 SK 90 R1 with adaptor

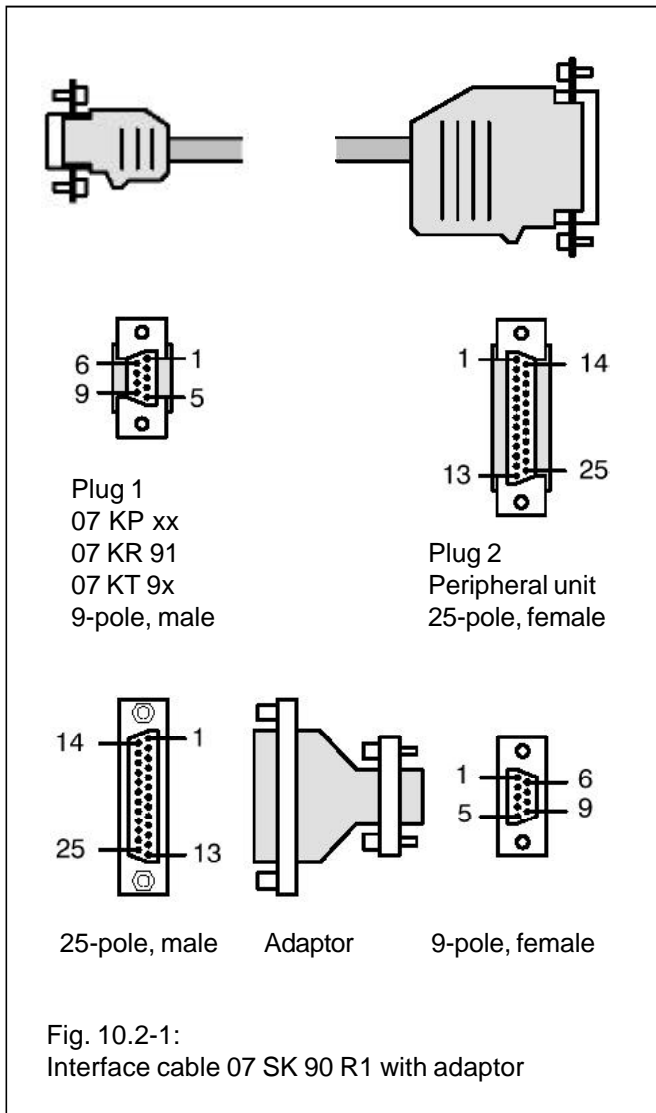

Fig. 10.2-1:
Interface cable 07 SK 90 R1 with adaptor

Intended purpose

The cable 07 SK 90 is used to connect a 9-pole interface connector of AC31 basic units or T200 communication processors with a peripheral unit in order to operate in programming or active mode (see 10.1.1 Survey table). If the peripheral has a 9-pole interface, the adaptor provided with (25-pole to 9-pole) can be employed for adaption.

Mechanical design

Plug 1

SUB-D plug, 9-pole male on the side of 07 KP 6x, 07 KR 91, 07 KT 9x. The housing is metal-plated, the shield is connected to the metal plate.

Plug 2

SUB-D plug, 25-pole female, on the side of the peripheral unit. The plugs are mounted to both interfaces by means of screws.

Cable type

LICYCY 5 x 0.14/15

Adaptor provided

25-pole male/9-pole female for connection of peripheral units with 9-pole interfaces (male).

Technical data

Length	5 m
Weight	220 g
Order number	GJR5 2502 00 R1

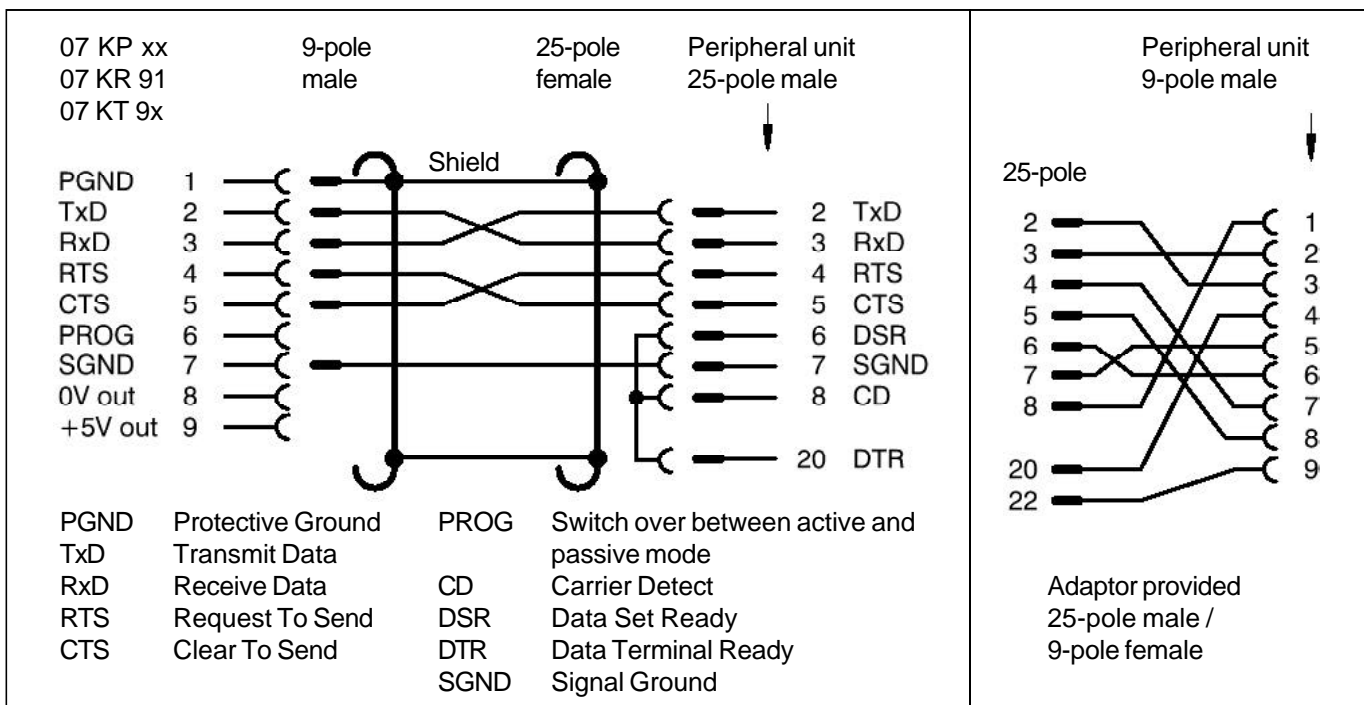
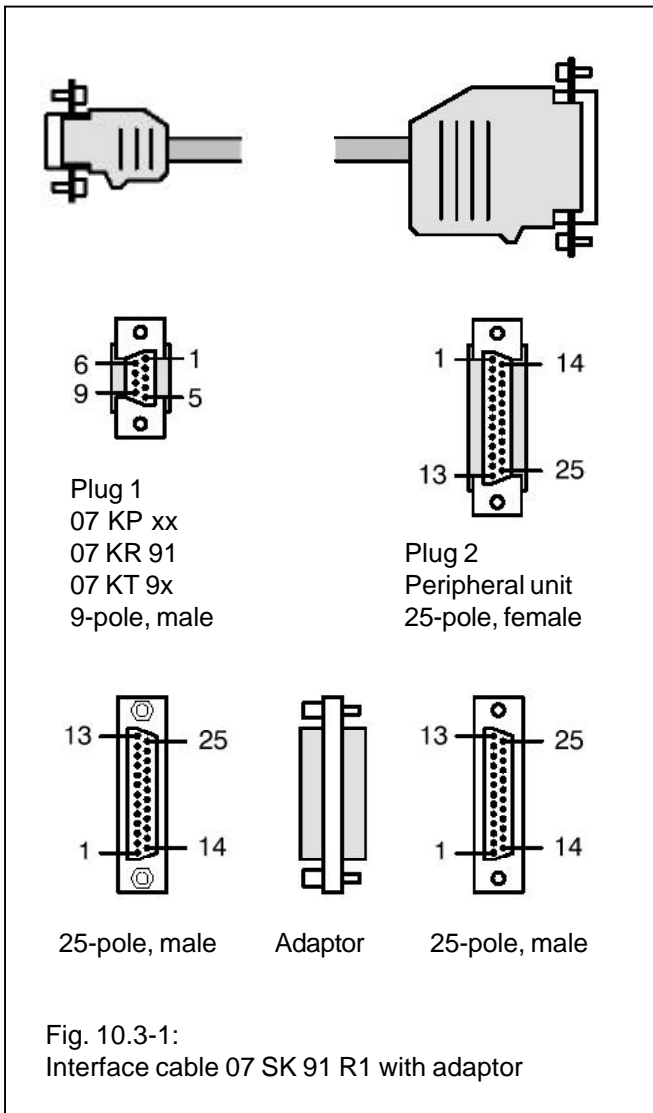

Fig. 10.2-2: Terminal assignment of the 07 SK 90 interface cable and the adaptor provided with

10.3 Interface cable 07 SK 91 R1 with adaptor



Intended Purpose

The cable 07 SK 91 is used to connect a 9-pole interface connector of AC31 basic units or T200 communication processors with a peripheral unit in order to operate in MMC mode or passive mode (see 10.1.1 Survey table). If the peripheral unit has a 9-pole connector, a commercially available adaptor (25-pole to 9-pole) has to be employed for adaption.

Mechanical design

Plug 1

SUB-D plug, 9-pole male on the side of 07 KP 6x, 07 KR 91, 07 KT 9x. The housing is metal-plated, the shield is connected to the metal plate.

Plug 2

SUB-D plug, 25-pole female on the side of the peripheral unit. The plugs are mounted to both interfaces by means of screws.

Cable type

LICYCY 5 x 0.14/15

Adaptor provided

25-pole male/25-pole male for connection of peripheral units with 25-pole interfaces (female).

Technical data

Length	5 m
Weight	220 g
Order number	GJR5 2503 00 R1

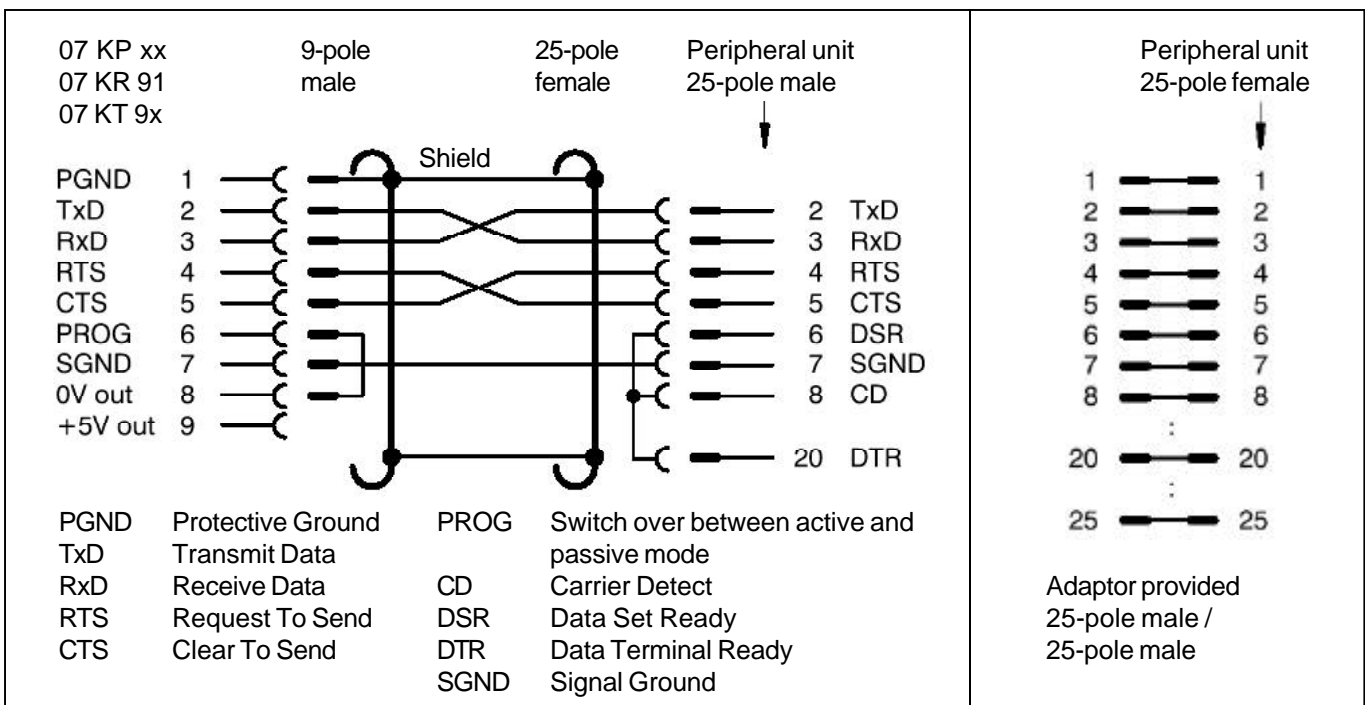
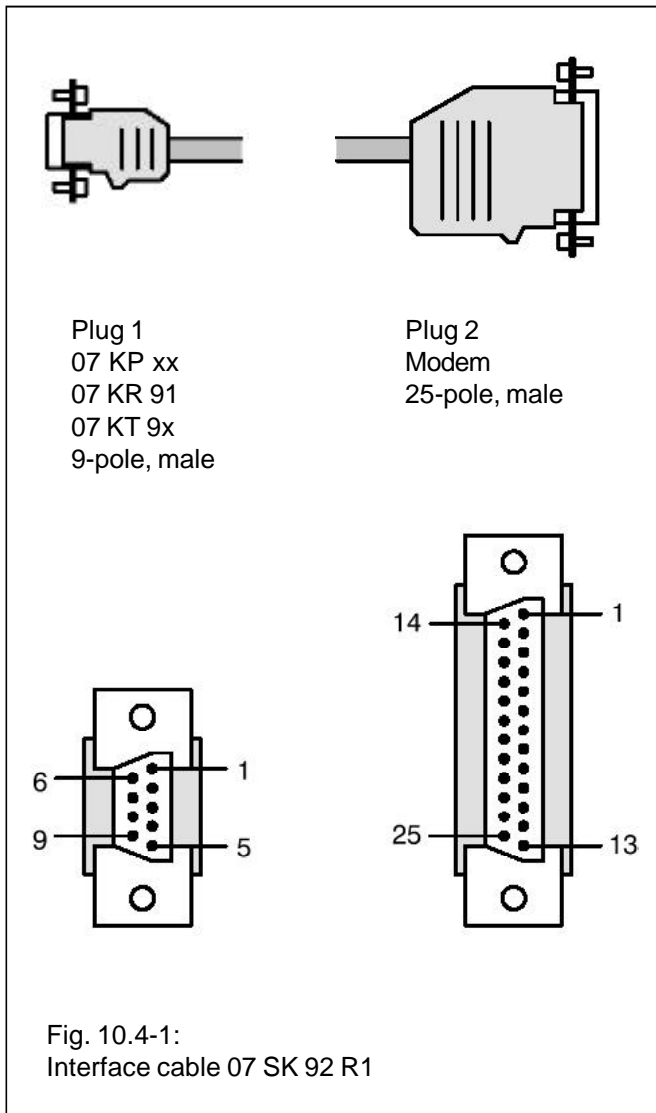

Fig. 10.2-3: Terminal assignment of the 07 SK 91 interface cable and the adaptor provided with

10.4 Interface cable 07 SK 92 R1



Intended purpose

The cable 07 SK 92 is used to connect a 9-pole interface connector of AC31 basic units or T200 communication processors to a modem with a standard interface (see 10.1.1 Survey table). If another modem has to be connected, the cable has to be modified possibly.

Mechanical design

Plug 1

SUB-D plug, 9-pole male on the side of 07 KP 6x, 07 KR 91, 07 KT 9x. The housing is metal-plated, the shield is connected to the metal plate.

Plug 2

SUB-D plug, 25-pole male on the side of the modem. The plugs are mounted to both interfaces by means of screws.

Cable type

LICYCY 5 x 0.14/15

Technical data

Length	5 m
Weight	220 g
Order number	GJR5 2504 00 R1

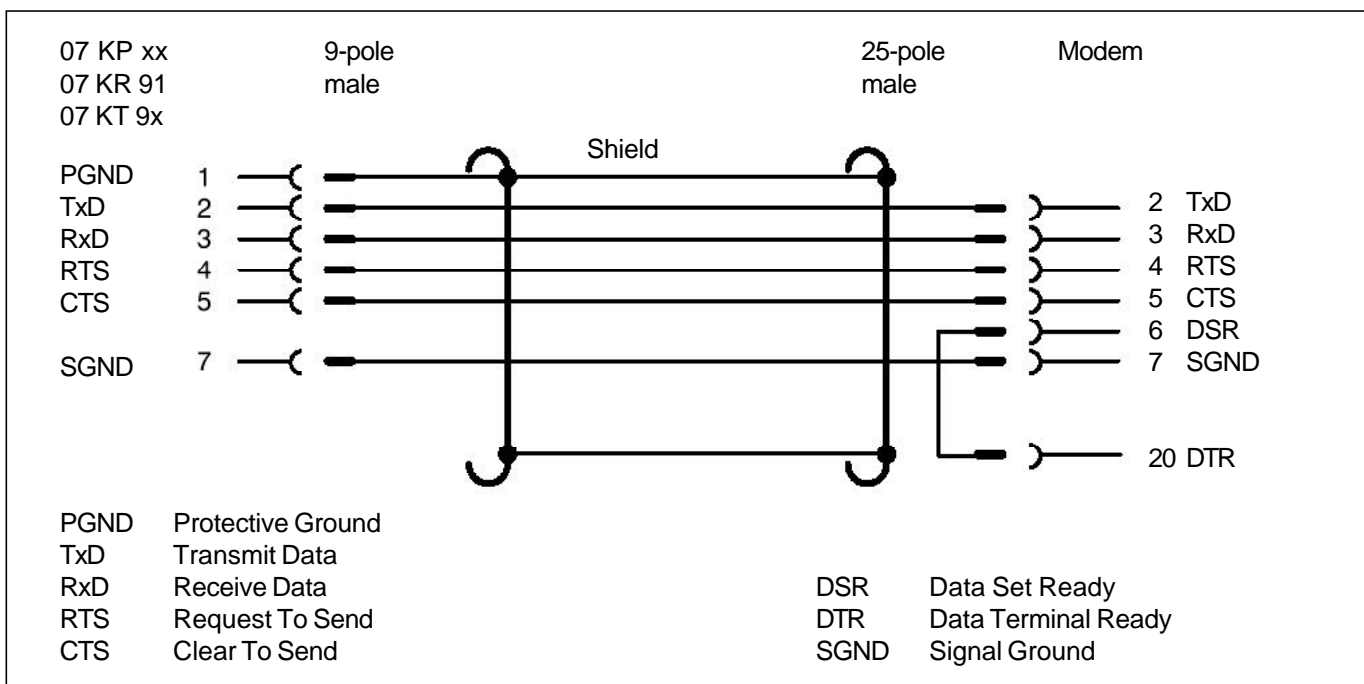

Fig. 10.2-4: Terminal assignment 07 SK 92



Printed on chlorine-free bleached paper

ABB Schalt- und Steuerungstechnik GmbH
Eppelheimer Straße 82 Postfach 10 50 09
D-69123 Heidelberg D-69040 Heidelberg

Telefon +49 6221 777-0
Telefax +49 6221 777-111
E-Mail desst.help@de.abb.com
Internet <http://www.abb-sst.de>

Printed in the Federal Republic of Germany (08.99)