

HD4

Installation and service instructions

12-40.5 kV – 630-3600 A – 16-50 kA

Index

1. Packing and transport	5
2. Checking on receipt	6
3. Storage	7
4. Handling	8
5. Description	10
6. Instructions for circuit-breaker operation	12
7. Installation	13
8. Putting into service	34
9. Periodical checking	36
10. Maintenance operations	36
11. Indications for handling apparatus with SF6	37
12. Spare parts and accessories	38



For your safety!

- Make sure that the installation room (spaces, divisions and ambient) are suitable for the electrical apparatus.
- Check that all the installation, putting into service and maintenance operations are carried out by qualified personnel with in-depth knowledge of the apparatus.
- Make sure that the standard and legal prescriptions are complied with during installation, putting into service and maintenance, so that installations according to the rules of good working practice and safety in the work place are constructed.
- Strictly follow the information given in this instruction manual.
- Check that the rated performance of the apparatus is not exceeded during service.
- Pay special attention to the danger notes indicated in the manual by the following symbol:
- Check that the personnel operating the apparatus have this instruction manual to hand as well as the necessary information for correct intervention.



Responsible behaviour safeguards your own and others' safety!

For any requests, please contact the ABB Assistance Service.

I. Introduction

This publication contains the information necessary for installation and putting into service of HD4 medium voltage circuit-breakers.

For correct usage of the product, please read this manual carefully.

For correct mounting of accessories and/or spare parts please refer to the relevant instructions.

Like all the apparatus manufactured by us, the HD4 circuit-breakers are designed for different installation configurations. They do, however, allow further technical-constructional variations (at the customer's request) to suit special installation requirements.

For this reason, the information given below does not always cover special configurations.

Apart from this booklet, it is therefore always necessary to refer to the latest technical documentation available (circuit diagram, wiring diagrams, assembly and installation drawings, any studies of protection co-ordination, etc.), especially with regard to any variations from standardized configurations requested.



All the operations regarding installation, putting into service, operation and maintenance must be carried out by suitably qualified personnel with in-depth knowledge of the apparatus.

Only use original spare parts for maintenance operations. For further information, also see the technical catalogue of the circuit-breaker and the spare parts catalogue.

II. Programme for the environmental protection

The HD4 circuit-breakers comply with ISO 14000 Standards (Guidelines for the Environmental Management).

The production system of the Medium Voltage factories complies for the environmental protection in terms of energy consumption, raw materials and waste.

The environmental impact of the product life cycle is assessed by the LCA - Life Cycle Assessment procedure, which is also the result of a well-focused project phase in the selection of materials, processes and packaging.

The Product environmental declaration is available for the HD4 circuit-breakers

Production techniques are carried out in order to achieve an easy dismantling and separation of the components at the end of the circuit-breaker life cycle, while optimizing the recycling process.

1. Packing and transport

The circuit-breaker is shipped in special packing in the open position with the springs discharged and with absolute pole pressure corresponding with the service value.

Each piece of apparatus is protected by a plastic film to prevent any infiltration of water during the loading and unloading stages and to keep the dust off during storage.

2. Checking on receipt



Before carrying out any operation, always make sure that the operating mechanism springs are discharged and that the apparatus is in the open position.

On receipt, check the state of the apparatus, that the packing is undamaged and that the nameplate data corresponds (see fig. 1) with that specified in the order acknowledgement and in the delivery note.

Also make sure that all the materials described in the shipping note are included in the supply.

If any damage or irregularity is discovered on unpacking, notify ABB (directly or through the agent or supplier) as soon as possible and in any case within five days of receipt.

The apparatus is only supplied with the accessories specified at the time of order and confirmed in the order acknowledgement sent by ABB.

The following accompanying documents are inserted in the shipping packing:

- Instruction manual (this document)
- Test certificate
- Identification tag
- Fiscal copy of shipping note
- Electrical diagram

These other documents are sent prior to shipment:

- Order acknowledgement
- Original copy of shipping note
- Any drawings or documents regarding special configurations/conditions.

The diagram shows a rectangular nameplate with the ABB logo at the top left. It is divided into several sections. A vertical line on the right side is labeled '2'. A horizontal line at the top is labeled 'A'. The main body of the nameplate is divided into two columns. The left column contains the following text: '1 CIRCUIT-BREAKER', 'HD4', '3 CLASSIFICATION', 'SN', 'M MASS ... Kg', 'Ur _____', '4 _____', '_____'. The right column contains: 'IEC 62271-100', 'CEI 17-1', 'PR. YEAR', 'm SF6 mass for circuit-breaker ... Kg'. Below this is a section labeled 'B' containing 'ELECTRIC DIAGRAM', 'FIG.', a barcode, and 'OPERATING MECHANISM'. At the bottom, a section labeled '5' contains '-MO1 V' and 'Made by ABB'.

Nameplate

Fig. 1

Caption

- A Circuit-breaker nameplate
- B Operating mechanism nameplate
- 1 Type of apparatus
- 2 Symbols and compliance with Standards
- 3 Serial number
- 4 Circuit-breaker characteristics
- 5 Characteristics of the operating auxiliaries

3. Storage

When a period of storage is foreseen, (on request) our workshops can provide suitable packing for the specified storage conditions.

On receipt the apparatus must be carefully unpacked and checked as described in Checking on receipt (chap. 2).

If immediate installation is not possible, the packing must be replaced, using the original material supplied.

Insert hygroscopic substances inside the packing, with at least one standard bag per piece of apparatus.

Should the original packing not be available and immediate installation is not possible, store in covered, well-ventilated, dry, dust-free, non-corrosive ambients, away from any flammable materials and at a temperature between $-5\text{ }^{\circ}\text{C}$ and $+45\text{ }^{\circ}\text{C}$.

In any case, avoid any accidental impacts or positioning which stresses the structure of the apparatus.

4. Handling

Before carrying out any operation, always check that the operating mechanism springs are discharged and that the apparatus is in the open position.

Circuit-breakers up to 24 kV

- To lift and handle the circuit-breaker, use the tool (1) (fig. 2a: shortest hooks for circuit-breakers up to 17.5 kV; all hooks for 24 kV circuit-breakers).
- Put the hooks (2) in the holes prepared in the circuit-breaker frame and lift.
- On completion of the operation (and in any case before putting into service) unhook the lifting tool (1) (fig. 2b) and dismantle the crosspiece (2) by unscrewing the screws (3).

36 kV circuit-breakers

- Attach the tools (1) to lift and handle the circuit-breaker (fig. 2c);
- Attach the hooks (2) as illustrated in fig. 2d and lift;
- On completion of the operation, remove the tools (1).

Always take great care during handling not to stress the insulating parts and the circuit-breaker terminals.



The apparatus must not be handled by inserting lifting devices directly under the apparatus itself. Should it be necessary to use this method, place the circuit-breaker on a sturdy supporting surface (see fig. 3).

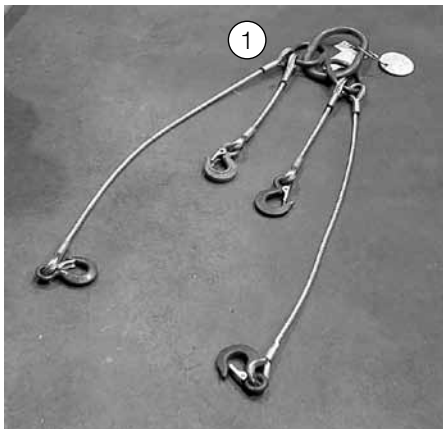

Fig. 2a

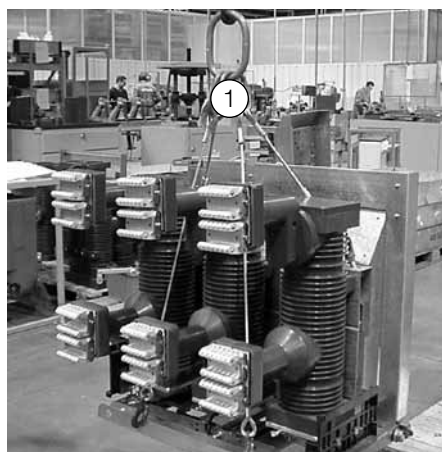
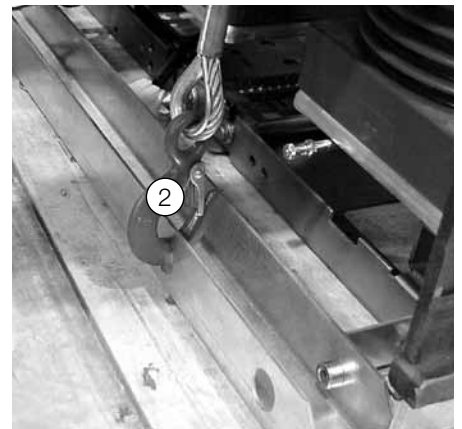
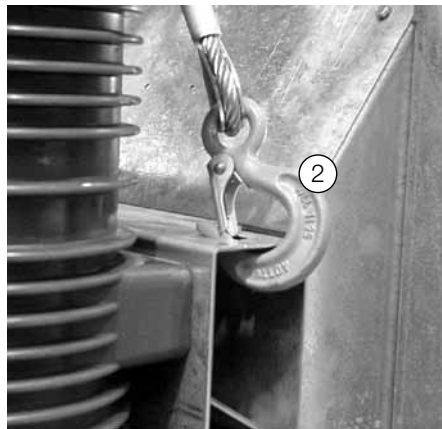
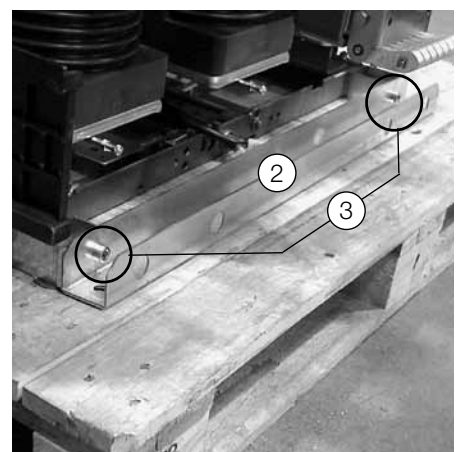

Fig. 2b



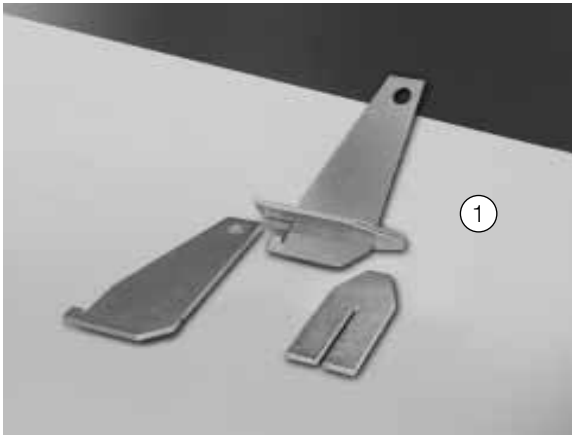

Fig. 2c

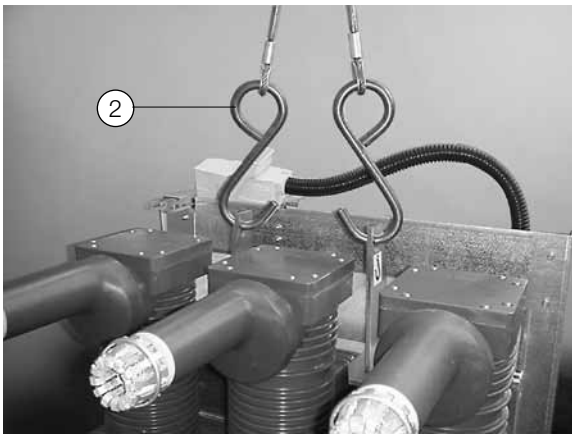

Fig. 2d

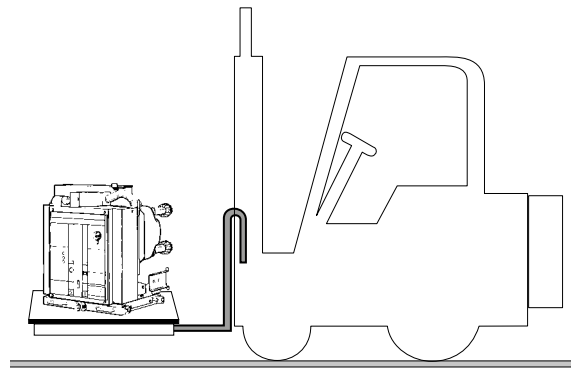

Fig. 3

5. Description

5.1. General features

The HD4 series are sulphur hexafluoride circuit-breakers for indoor installation. For the electrical performance, please refer to the corresponding technical catalogue code 1VCP000004. For special installation conditions please ask ABB.

The following versions are available:

- fixed
- withdrawable for CBE, PowerCube enclosures and CBF fixed parts
- withdrawable for switchgear: UniGear type ZS1, UniGear type ZS2, UniGear type ZS3.2
- withdrawable for switchgear: UniSwitch, UniMix.

5.2. Reference Standards

The HD4 series circuit-breakers comply with the following Standards:

- IEC 62271-100
- CEI 17-1 (file 1375).

5.3. Fixed circuit-breaker

The fixed circuit-breaker (see fig. 4) corresponds to the basic version complete with a front protection shield and frame. The anchoring holes are drilled in the lower part of the frame. The terminal box, fixed on the upper protection, is available for connection of the circuit-breaker auxiliary circuits. The earthing screw is located on the circuit-breaker side. For further details, refer to the caption of fig. 4.

5.4. Withdrawable circuit-breaker

The withdrawable circuit-breakers (see fig. 5) are consist of a truck on which the supporting structure of the circuit-breaker itself is fixed. The cord with the connector (plug) for connection of the operating mechanism electrical accessories comes out of the front protection of the circuit-breaker.

Fixed circuit-breaker

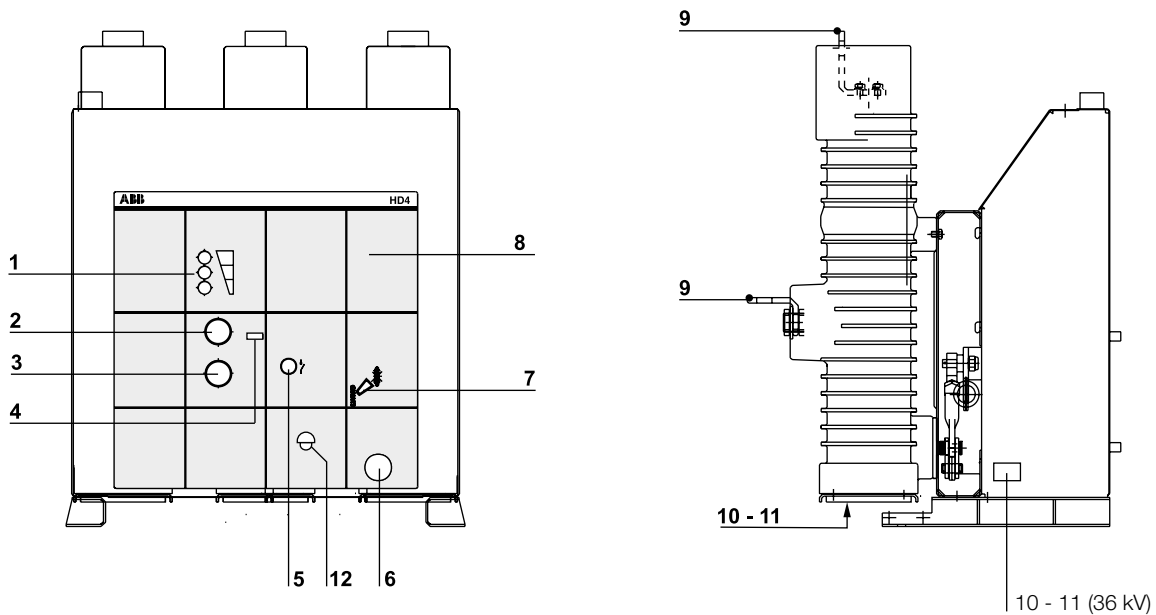

Fig. 4

Caption

- 1 Signalling device for state of SF6 pressure (on request)
- 2 Opening push button
- 3 Closing push button
- 4 Operator counter
- 5 Signalling device for circuit-breaker open/closed
- 6 Shaft for manual closing spring charging

- 7 Signalling device for closing springs charged/discharged
- 8 Characteristics nameplate
- 9 Terminals
- 10 Pressure switch (on request)
- 11 Valve for checking the SF6 gas pressure
- 12 Resetting button for protection circuit-breaker of geared motor (on request)

The strikers for activating the contacts (connected/isolated), located in the enclosure or in the switchgear, are fixed in the top part of the circuit-breaker. The slides for activating the segregation shutters of the medium voltage contacts of the enclosure or switchgear are fixed on the sides of the circuit-breaker. The crosspiece for hooking the circuit-breaker for the connection/isolation operation by means of the special operating lever is mounted on the front part of the circuit-breaker truck.

The circuit-breaker is completed with the tulip isolating contacts. The withdrawable circuit-breaker is fitted with special locks, on the front crosspiece, which allow hooking into the corresponding joints in the enclosure or fixed part. The locks can only be activated by the handles with the truck resting completely on the crosspiece.

The activating lever (connection/isolation) must be fully inserted. A lock prevents the truck from advancing into the enclosure or fixed part (for example when the earthing switch is closed). With the truck in the middle position between isolated and connected, the lock prevents closure of the circuit-breaker (both mechanical and electrical). On request, a locking magnet can be mounted on the truck which, when de-energised, prevents truck operation.

5.5. Enclosures and fixed parts

For information about the enclosures and fixed parts, please consult the relative documentation.

Withdrawable circuit-breaker

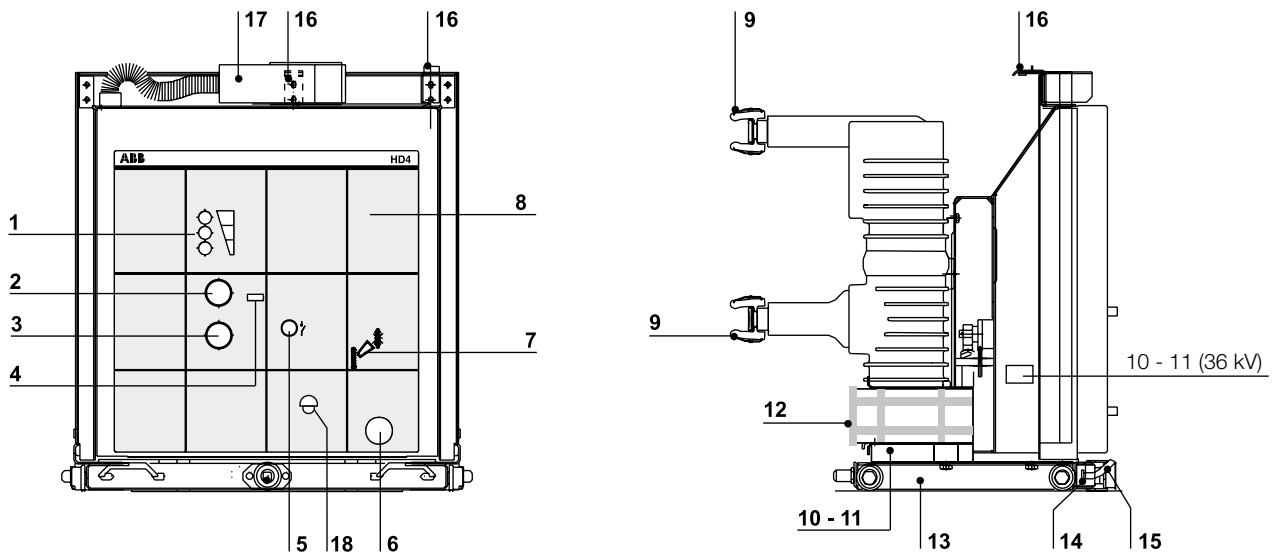

Fig. 5

Caption

- | | |
|--|--|
| <ul style="list-style-type: none"> 1 Signalling device for state of SF6 pressure (on request) 2 Opening push button 3 Closing push button 4 Operator counter 5 Signalling device for circuit-breaker open/closed 6 Shaft for manual closing spring charging 7 Signalling device for closing springs charged/discharged 8 Characteristics nameplate 9 Isolating contacts | <ul style="list-style-type: none"> 10 Pressure switch (on request) 11 Valve for checking the SF6 gas pressure 12 Slide for activating the enclosure shutters 13 Truck 14 Locks for hooking into the fixed part 15 Lock activating handles (17) 16 Strikers for activating the contacts located in the enclosure 17 Connector (plug) 18 Resetting button for protection circuit-breaker of geared motor (on request) |
|--|--|

6. Instructions for circuit-breaker operation

6.1. Safety indications



HD4 circuit-breakers ensure a minimum degree of protection IP2X if installed under the following conditions:

- fixed version, with protection netting
 - withdrawable version, installed in a switchgear.
- Under these conditions, the operator is guaranteed against accidental contact with moving parts. Should any mechanical operations be carried out on the circuit-breaker outside the switchgear or with the protection netting removed, be very careful of any moving parts.**

If the operations are prevented, do not force the mechanical interlocks and check that the operation sequence is correct.

The racking-in and racking-out operations of the circuit-breaker must be carried out gradually to prevent any impacts which might deform the mechanical interlocks.

6.2. Operating and signalling parts

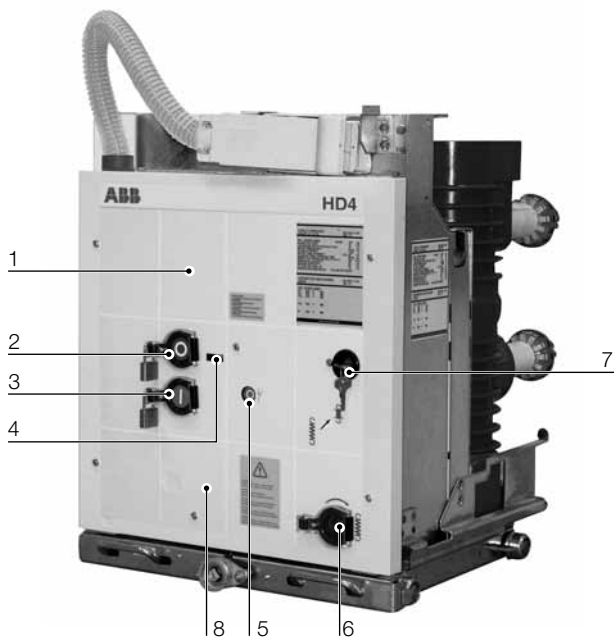

Fig. 6

Caption

- 1 Signalling device for state of SF6 pressure (on request)
- 2 Opening push button
- 3 Closing push button
- 4 Operator counter
- 5 Signalling device for circuit-breaker open/closed
- 6 Shaft for manual closing spring charging
- 7 Signalling device for closing springs charged/discharged
- 8 Resetting button for protection circuit-breaker of geared motor (on request)

6.3. Circuit-breaker closing and opening operations (fig. 6)

Circuit-breaker operation can be manual or electrical.

a) Manual operation for spring charging

To manually charge the closing springs, it is necessary fully insert the charging lever into the seat (6) and turn it clockwise until the yellow indicator (7) appears.

The force which can normally be applied to the charging lever fitted is 130 N. In any case, the maximum force which can be applied must not exceed 170 N.

b) Electrical operation for spring charging

On request the circuit-breaker can be fitted with the following accessories for electrical operation:

- geared motor for automatic charging of the closing springs
- shunt closing release
- shunt opening release.

The geared motor automatically recharges the springs after each closing operation until the yellow indicator (7) appears. Should there be no voltage during charging, the geared motor stops and then starts recharging the springs automatically when the voltage is on again. It is, however, always possible to complete the charging operation manually.

c) Circuit-breaker closing

This operation can only be carried out with the closing springs completely charged.

For manual closing, push the push button (3).

When there is a shunt closing release, the operation can also be carried out with remote control by means of a control circuit. The indicator (4) shows that closing has been accomplished.

In case of earthing truck with making capacity, activate the key lock (in the closed position) and remove the key.

This is to prevent accidental opening operations during any maintenance work on the installation.

d) Circuit-breaker opening

For manual opening, push the push button (2).

When there is a shunt opening release, the operation can also be carried out with remote control by means of a control circuit. The indicator (4) shows that opening has been accomplished.

7. Installation

7.1. General



Correct installation is of prime importance. The instructions given by the manufacturer must be carefully studied and followed. It is good practice to use gloves to handle the pieces during installation.

7.2. Normal installation conditions

Maximum ambient air temperature	+ 40 °C
Minimum ambient air temperature	- 5 °C
Relative humidity	% ≤ 95
Altitude	≤ 1000 m

It must be possible to ventilate the installation room.
For other installation conditions, please follow what is indicated in the product Standards.

For special installation requirements please contact us.
The areas affected by the passage of power conductors or auxiliary circuit conductors must be protected against the possible access of animals which could cause damage or anomalous service.

7.3. Preliminary operations

- Clean the insulating parts with clean dry rags.
- Check that the upper and lower terminals are clean and free of any deformation caused by shocks received during transport or storage.

7.4. Installation of fixed circuit-breaker

The circuit-breaker can be mounted directly on the supporting frames provided by the customer.

The circuit-breaker, complete with supporting truck, must be fixed to the floor of its compartment with special brackets. The parts of the floor surface on which the truck wheels rest must be perfectly level.

The areas on which the supporting frames or truck wheels rest (if a truck is provided) must be on the same horizontal plane to avoid any risk of distortion in the breaker frame.

Fit the isolating partitions if provided.

A minimum degree of protection (IP2X) must be guaranteed from the front towards live parts.

7.5. Installation of withdrawable circuit-breaker

The withdrawable circuit-breakers are preset for insertion in enclosures, in fixed parts or in the corresponding switchgears. Insertion and racking-out of the circuit-breakers must be gradual to avoid any shocks which could deform the mechanical interlocks.

If the operations are prevented, do not force the interlocks and check that the operating sequence is correct. The force normally applicable to the insertion/racking-out lever is 250 N. Please also refer to the technical documentation of the enclosures and switchgears for the circuit-breaker installation operations.

CAUTION!

The insertion and racking-out operations must always be carried out with the circuit-breaker open.

7.6. Fixed circuit-breaker power circuit connections

7.6.1. General directions

- The connections must be made using only the squares-terminals supplied with the circuit-breaker.
- Select the conductor cross-section according to the operating and short-circuit current of the installation.
- Near the terminals of fixed version circuit-breakers or enclosure, provide suitable support insulators dimensioned according to the electrodynamic stresses that may arise from the short-circuit current of the installation.
- Fit the isolating partitions if provided.

7.6.2. Mounting the connections

- Check that the connection contact surfaces are perfectly flat and have no burrs, oxidation traces, or deformations due to drillings or impacts.
- Depending on the conductive material and surface treatment used, carry out the operations indicated in the table on the contact surface of the conductor.

Mounting procedures

- Place the connections in contact with the circuit-breaker terminals.
- Interpose a spring washer and a flat washer between the head of the bolt and the connection.
- Tighten the bolt, taking care not to subject the insulating parts to stress (see table tightening torque).
- Make sure that the connections do not exert force on the terminals.
- In case of cable connections, carefully follow the manufacturer's instructions for terminating the cables.

Table of tightening torque

Screw	Tightening torque
M6	10 Nm
M8	30 Nm
M10	40 Nm
M12	70 Nm

Bare copper	Silver-plated copper or aluminium	Bare aluminium
– Clean with a fine file or emery cloth.	– Clean with a rough dry rag.	– Clean with a metallic brush or emery cloth.
– Fully tighten and smear a film of industrial vaseline grease over the contact surfaces.	– In case of tough oxidation traces only, clean with a very fine emery cloth, taking care not to remove the surface layer.	– Immediately smear a film of industrial vaseline grease over the contact surfaces.
– Interpose the copper-aluminium bi-metal with restored surfaces between the aluminium connection and the copper terminal (copper side in contact with the terminal; aluminium side in contact with the connection).	– If necessary, recondition the surface treatment.	

7.7. Earthing

For fixed version circuit-breakers, use the screw marked with the relative symbol to effect the earthing.

Clean and degrease the surrounding area for a diameter of about 30 mm. After completion of the assembly, cover the entire joint with vaseline.

Use a conductor (busbar or braid) with a cross-section as indicated in the Standards in force.

7.8. Auxiliary circuit connection

Notes

- **The minimum cross-section of the wires used for the auxiliary circuits must not be less than that used for internal wirings.**
- **Before carrying out the connection of the auxiliary circuits, it is advisable to check the selected type of automatism provided for operation of the pressure switch (if provided) referring to the latest technical documentation supplied by ABB.**

7.8.1. Fixed circuit-breaker

The connection of the circuit-breaker auxiliary circuits must be made via the terminal box mounted on the circuit-breaker structure.

Outside the circuit-breaker the wires must run inside appropriately earthed metal tubes or ducts.



Before removing the operating mechanism cover to access the terminal box, make sure that the circuit-breaker is open and the closing springs discharged.

7.8.2. Withdrawable circuit-breaker

The auxiliary circuits of the withdrawable circuit-breaker are fully cabled in the factory as far as the connector. For the external connections, please refer to the electric diagram of the enclosure or of the switchgear.

7.9. Overall dimensions

Fixed circuit-breakers

HD4	
TN	7177
Ur	12 kV
Ir	630 A
	1250 A
	1600 A
Isc	16 kA
	25 kA
	31.5 kA

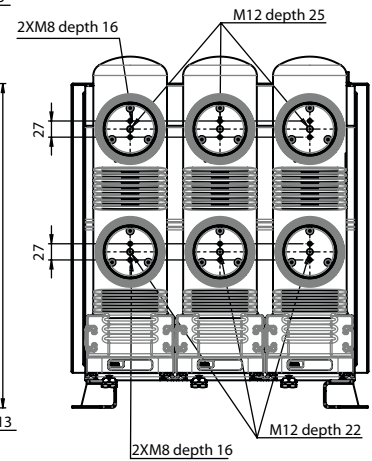
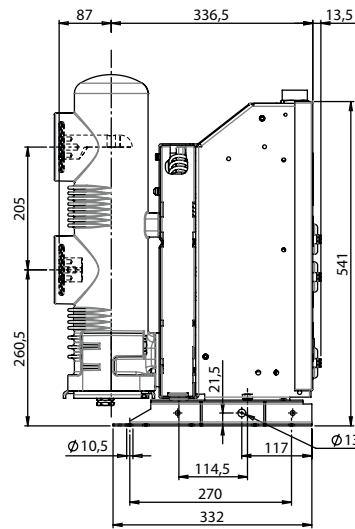
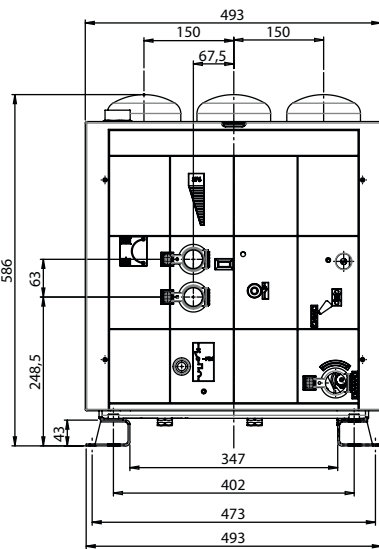

Fixed circuit-breakers

HD4	
TN	7177
Ur	12 kV
Ir	630 A
	1250 A
Isc	16 kA
	31,5 kA

HD4	
TN	7177
Ur	12 kV
Ir	1600 A
Isc	16 kA
	25 kA
	31,5 kA

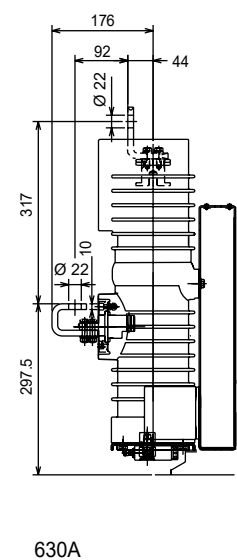
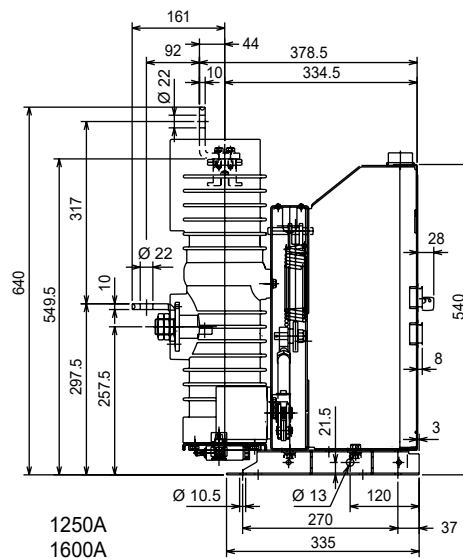
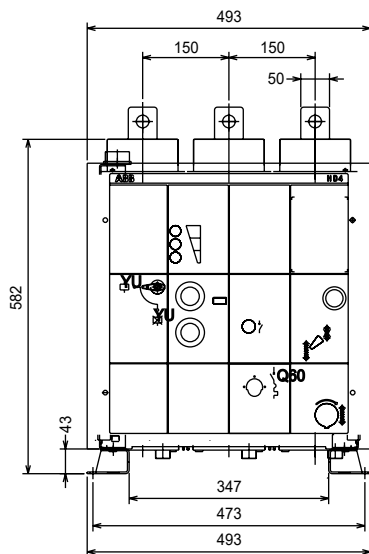

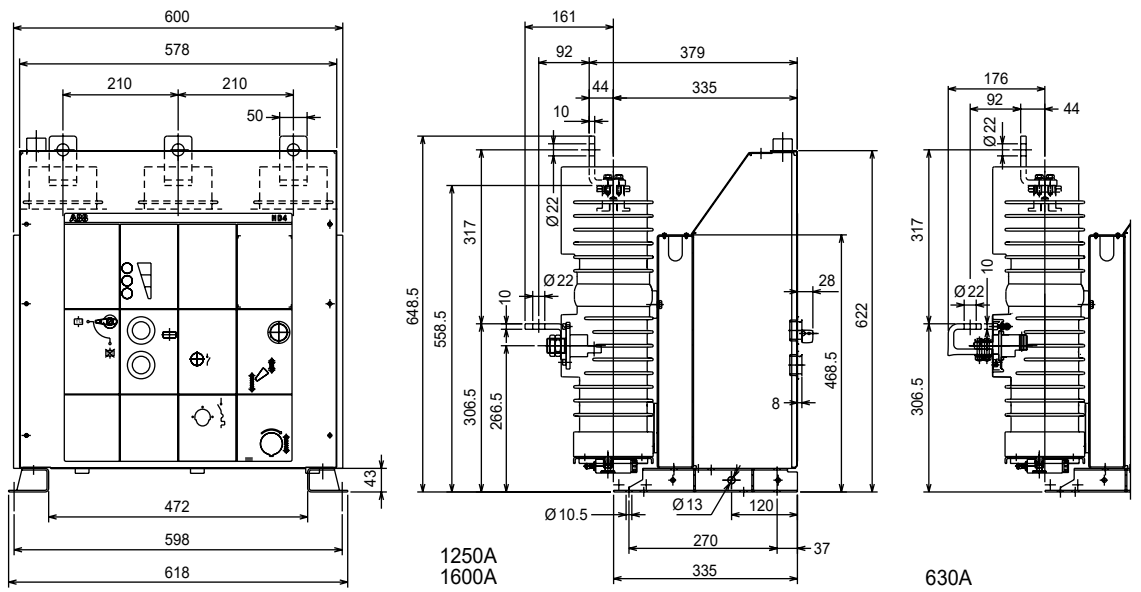

Fixed circuit-breakers

HD4	
TN	7163
Ur	12 kV
	17,5 kV
Ir	1600 A
Isc	40 kA
	50 kA

HD4	
TN	7163
Ur	12 kV
	17,5 kV
Ir	2000 A
Isc	25 kA
	31,5 kA
	40 kA
	50 kA

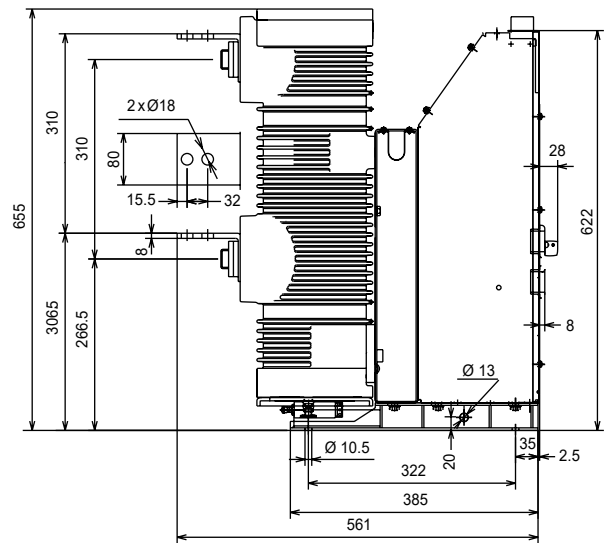
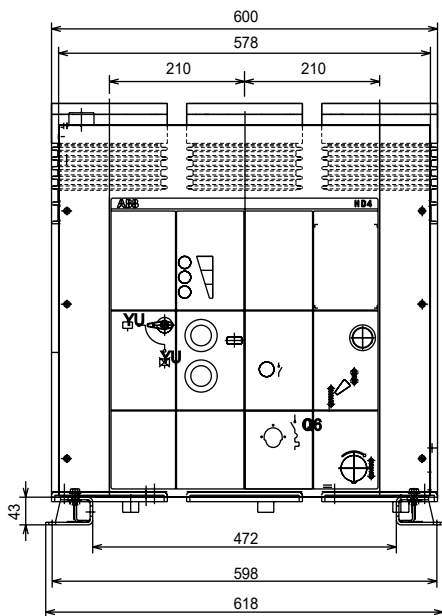

Fixed circuit-breakers

HD4	
TN	7165
Ur	12 kV
	17,5 kV
Ir	2500 A
	3150 A
	3600 A
Isc	25 kA
	31.5 kA
	40 kA
	50 kA

HD4	
TN	7165
Ur	24 kV
	24 kV
Ir	2500 A
	3150 A
	3600 A
Isc	25 kA
	31.5 kA
	40 kA

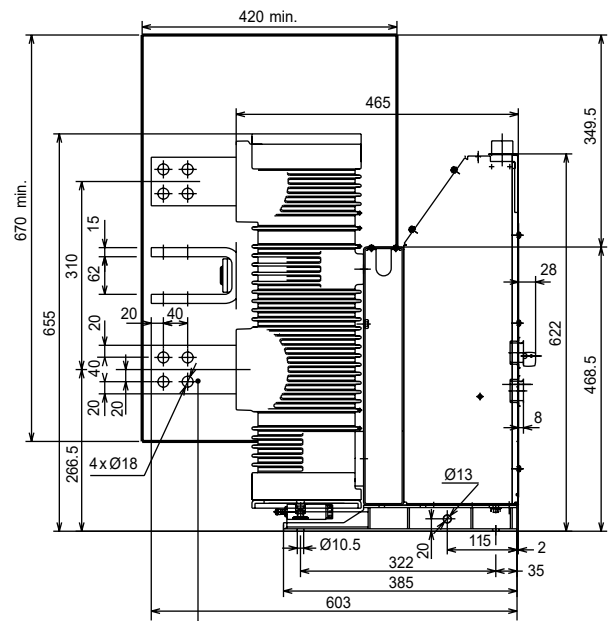
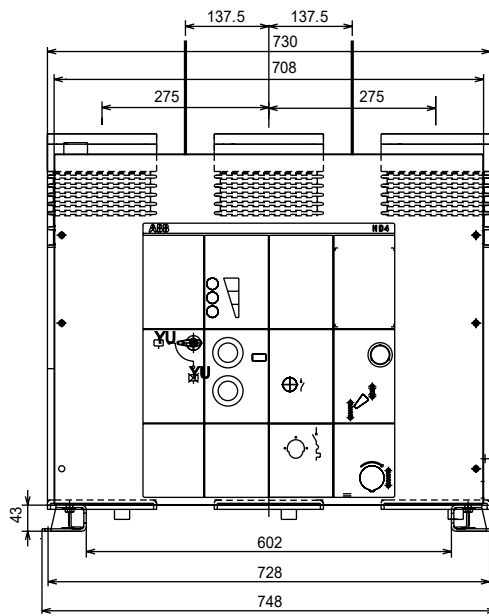

Insulating partitions (only for 24 kV)
to be provided by the customer
(a special kit is available on request).

Fixed circuit-breakers

HD4	
TN	7179
Ur	24 kV
	24 kV
Ir	630 A
	1250 A
	1600 A
Isc	16 kA
	20 kA
	25 kA

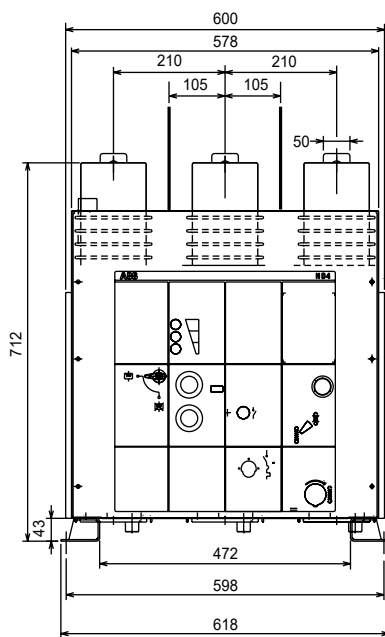

1250A
1600A

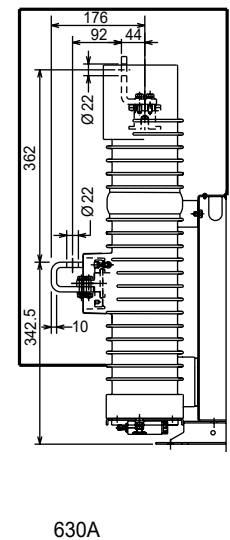
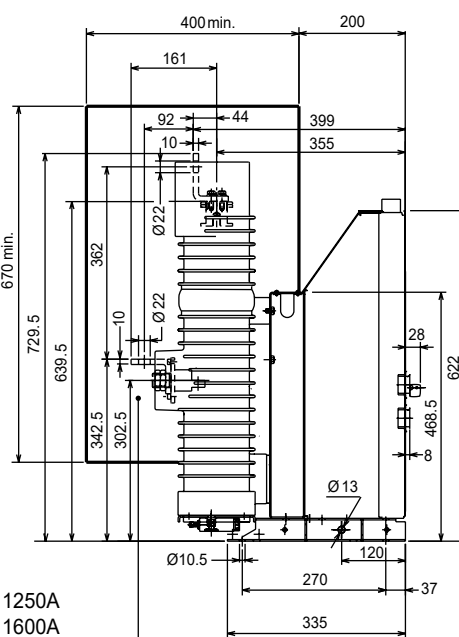

630A

Insulating partitions to be provided by the
customer (a special kit is available on request).

Fixed circuit-breakers

HD4		
TN	7242	
Ur	24	kV
Ir	630	A
	1250	A
	1600	A
Isc	16	kA
	20	kA
	25	kA

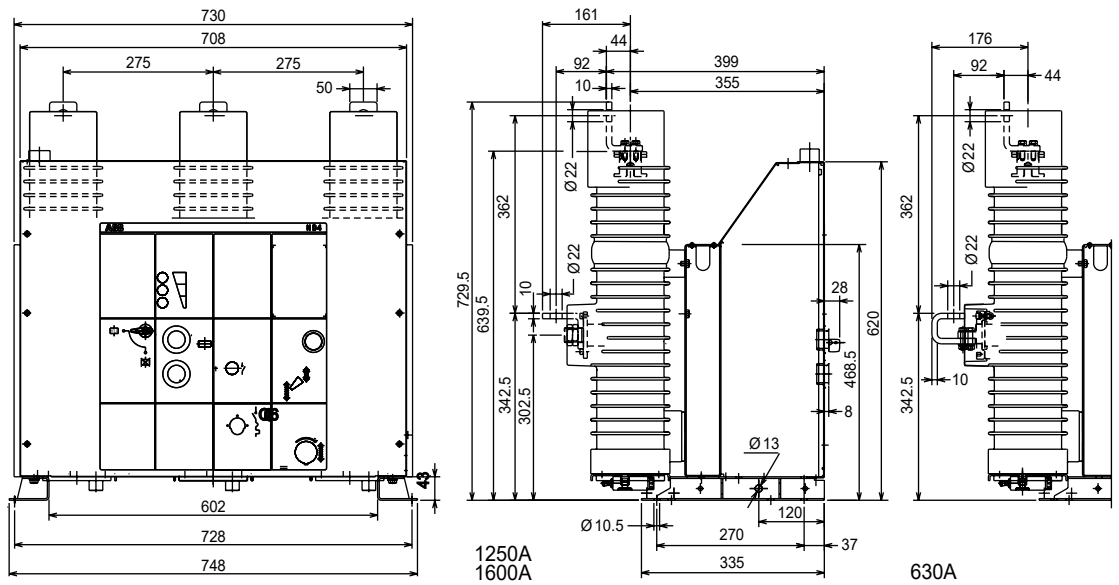

Fixed circuit-breakers

HD4		
TN	7174	
Ur	24	kV
Ir	1600	A
Isc	31,5	kA
	40	kA

HD4		
TN	7174	
Ur	24	kV
Ir	2000	A
Isc	25	kA
	31,5	kA
	40	kA

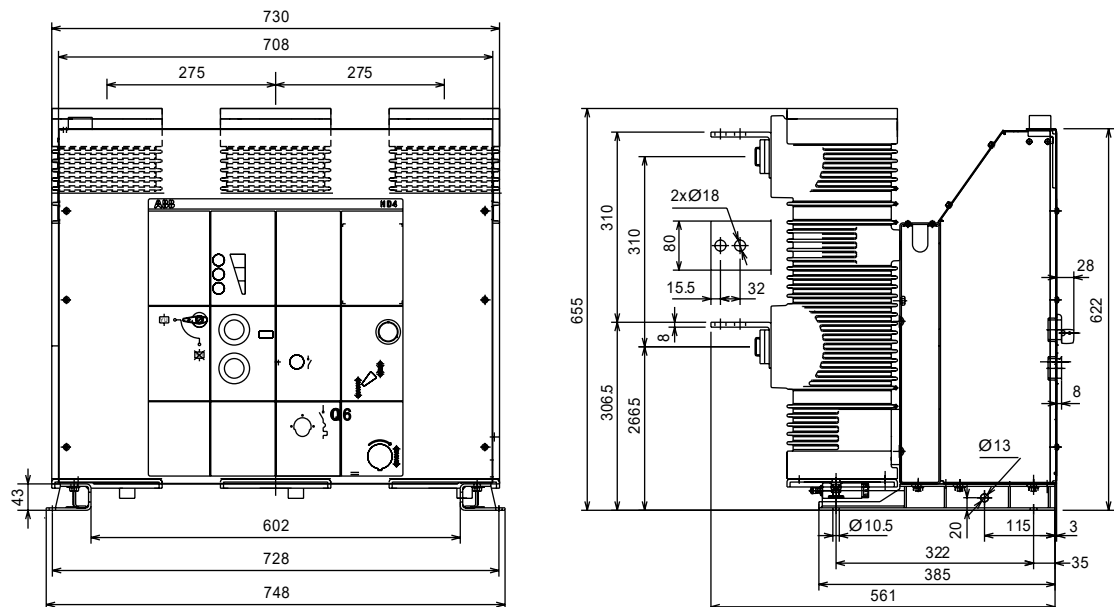

HD4/P withdrawable circuit-breakers for UniGear type ZS1 switchgears

HD4/P

TN	1VCD000227	
Ur	12	kV
	17.5	A
Ir	630	A
	1250	A
Isc	16	kA
	25	kA

Also suitable for Power-Cube PB1

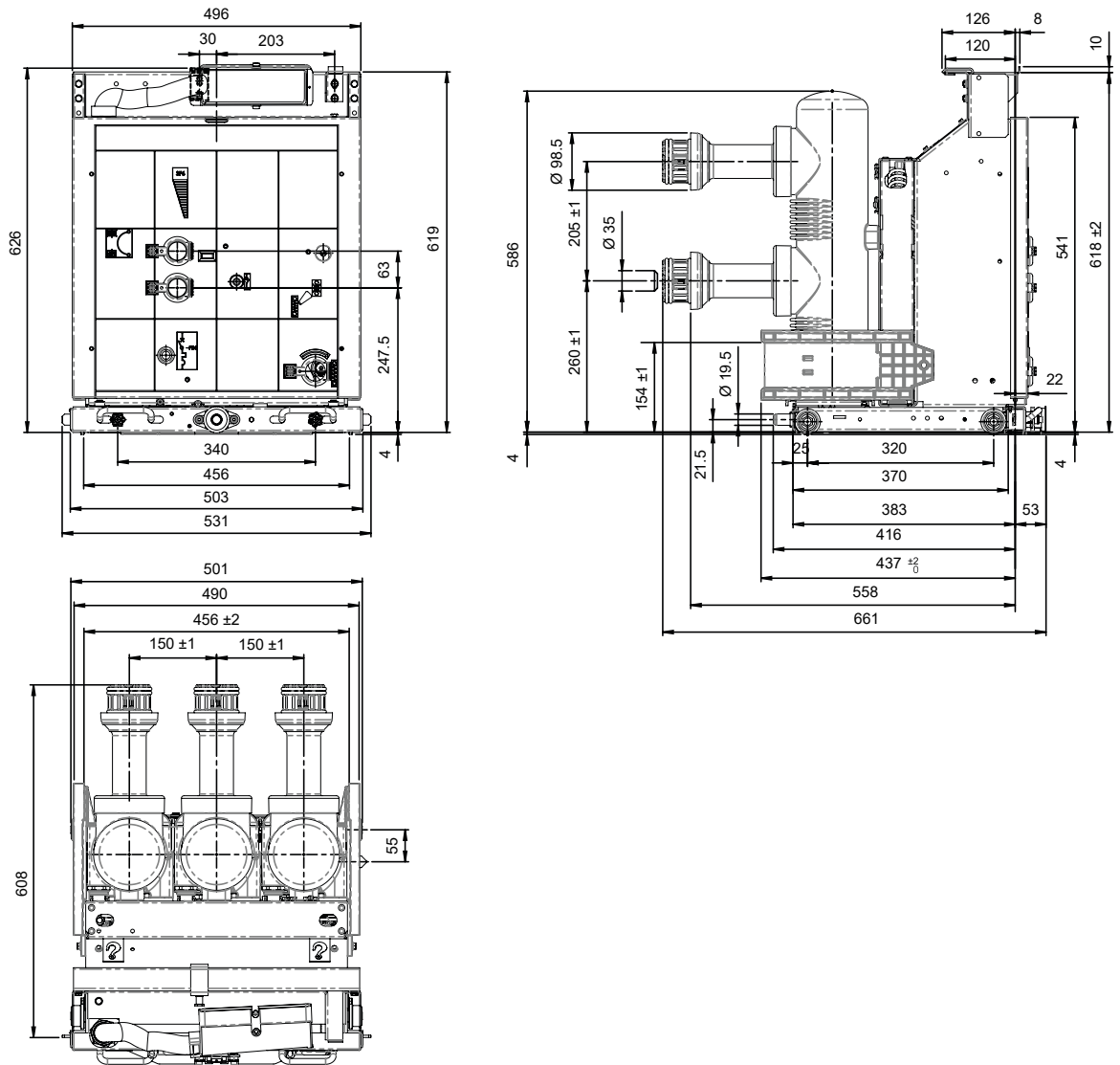

HD4/P withdrawable circuit-breakers for UniGear type ZS1 switchgears

HD4/P	
TN	7286
Ur	12 kV
	17,5 kV
I _r	630 A
	1250 A
I _{sc}	31,5 kA

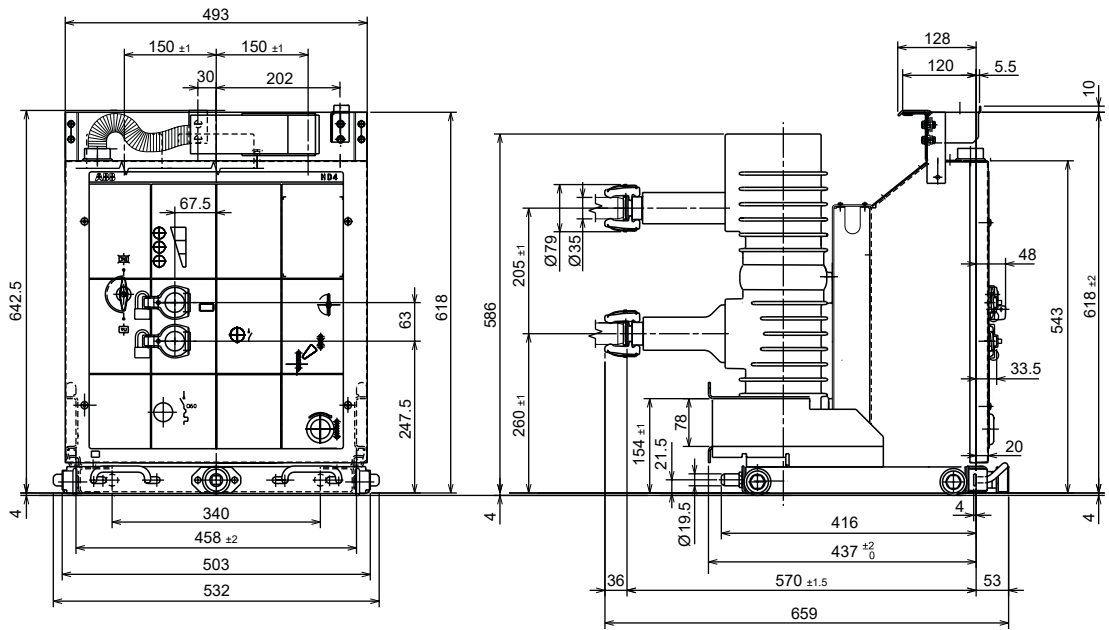

HD4/P withdrawable circuit-breakers for UniGear type ZS1 switchgears

HD4/P	
TN	7350
Ur	12 kV
	17,5 kV
I _r	1250 A
I _{sc}	40 kA

HD4/P	
TN	7350
Ur	12 kV
	17,5 kV
I _r	1600 A
	31,5 kA
	40 kA (*)
I _{sc}	50 kA (*)

(*) Also suitable for PowerCube PB2.

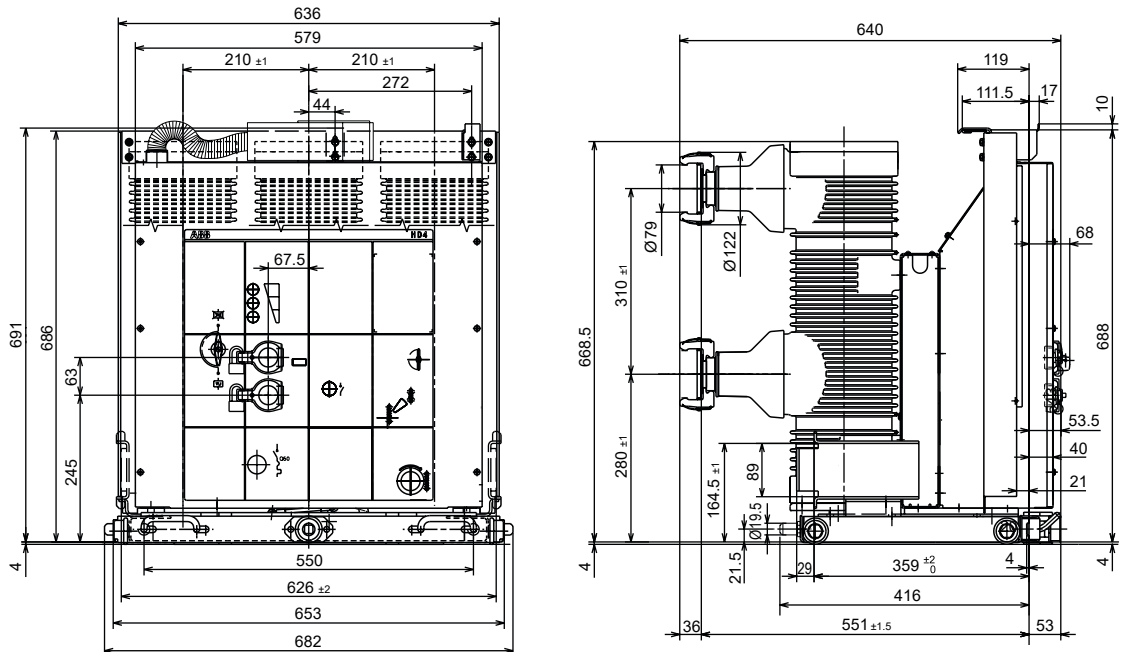

HD4/P withdrawable circuit-breakers for UniGear type ZS1 switchgears

HD4/P

TN	7351	
Ur	12	kV
	17.5	kV
Ir	2000 A	
Isc	25	kA
	31.5	kA (*)
	40	kA (*)
	50	kA (*)

(*) Also suitable for PowerCube PB2.

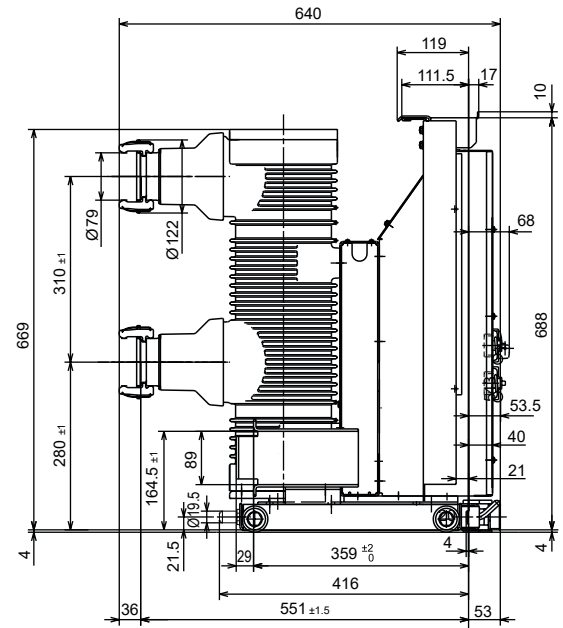
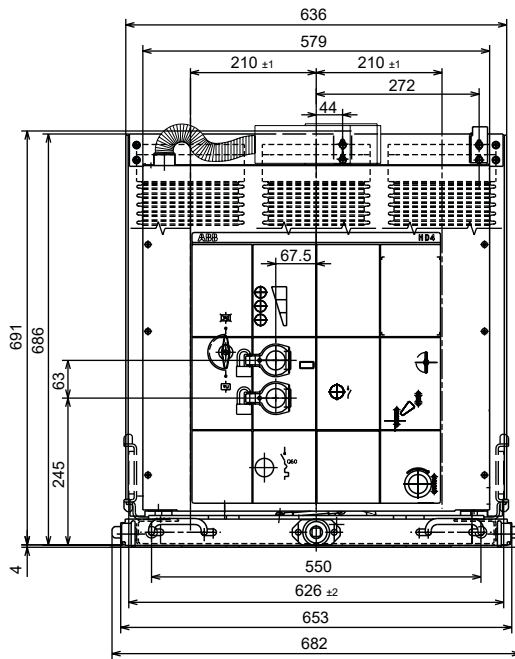

HD4/P withdrawable circuit-breakers for UniGear type ZS1 switchgears

HD4/P

TN	7352	
Ur	12	kV (*)
	17.5	kV
Ir	2500 A	
Isc	25	kA
	31.5	kA
	40	kA
	50	kA

(*) Also suitable for PowerCube PB3.

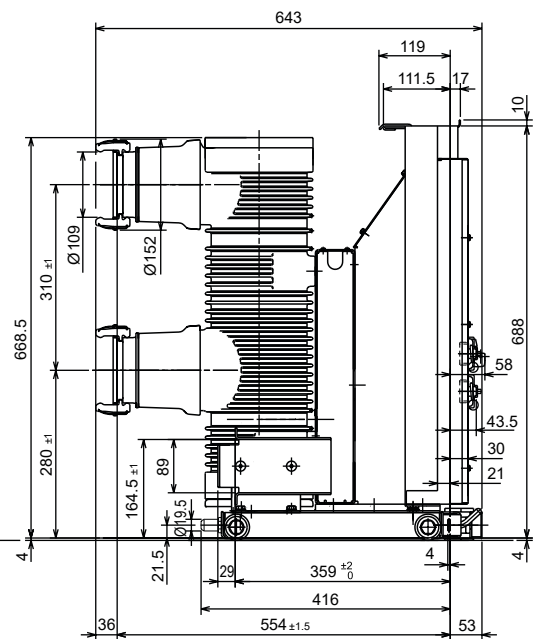
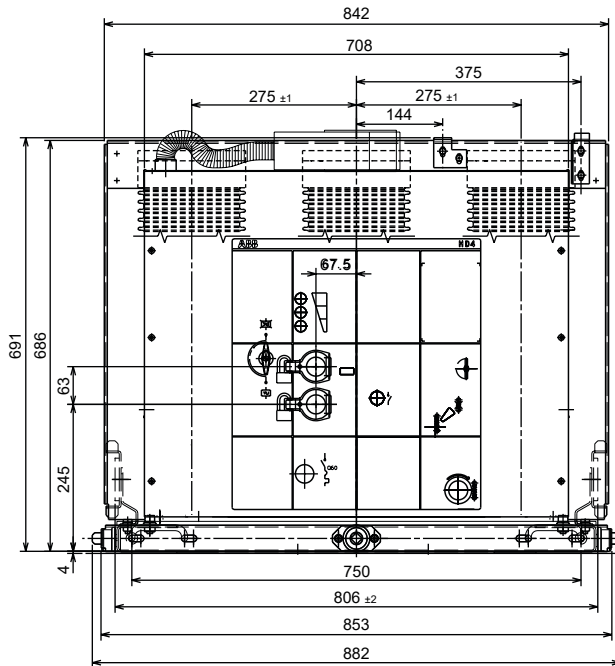

HD4/P withdrawable circuit-breakers for UniGear type ZS1 switchgears

HD4/P

TN	7371
Ur	12 kV
	17.5 kV
Ir	3150 A (*)
Isc	25 kA
	31.5 kA
	40 kA
	50 kA

(*) 3150 A with forced switchgear ventilation (consult the UniGear type ZS1 switchgear technical catalogue).

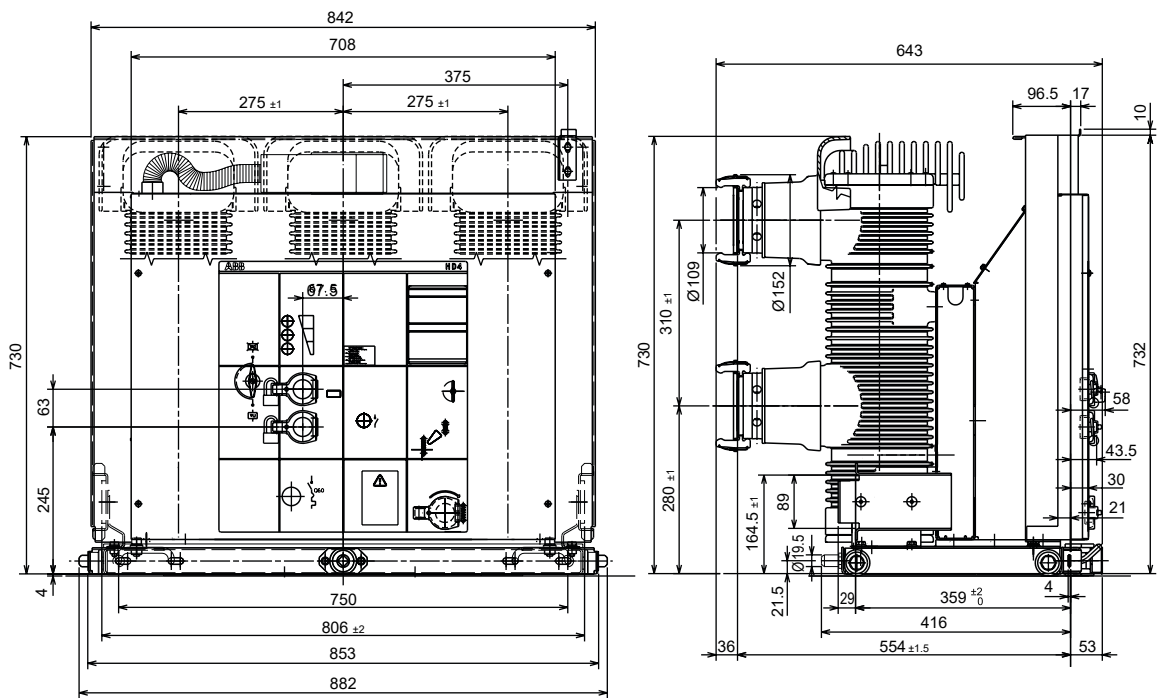

HD4/P withdrawable circuit-breakers for UniGear type ZS1 switchgears

HD4/P

TN	7354
Ur	24 kV
	1250 A
Ir	630 A
Isc	16 kA (*)
	20 kA
	25 kA

(*) 630 A only.

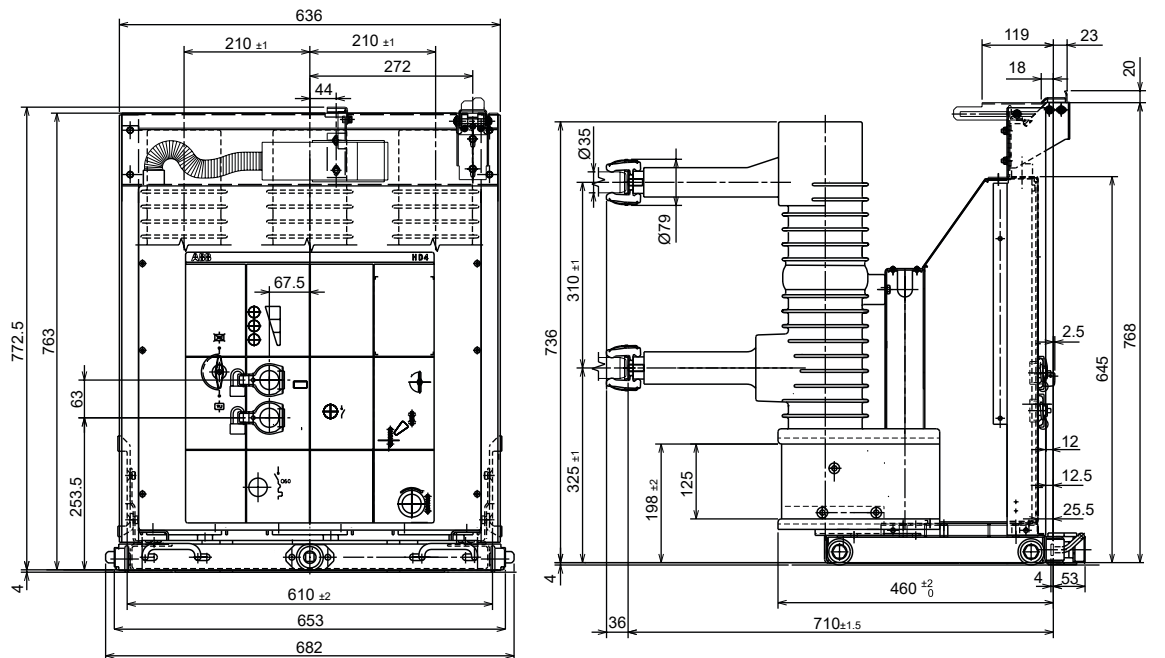

HD4/P withdrawable circuit-breakers for UniGear type ZS1 switchgears

HD4/P

TN	1VCD000099
Ur	24 kV
Ir	1250 A
Isc	31.5 kA

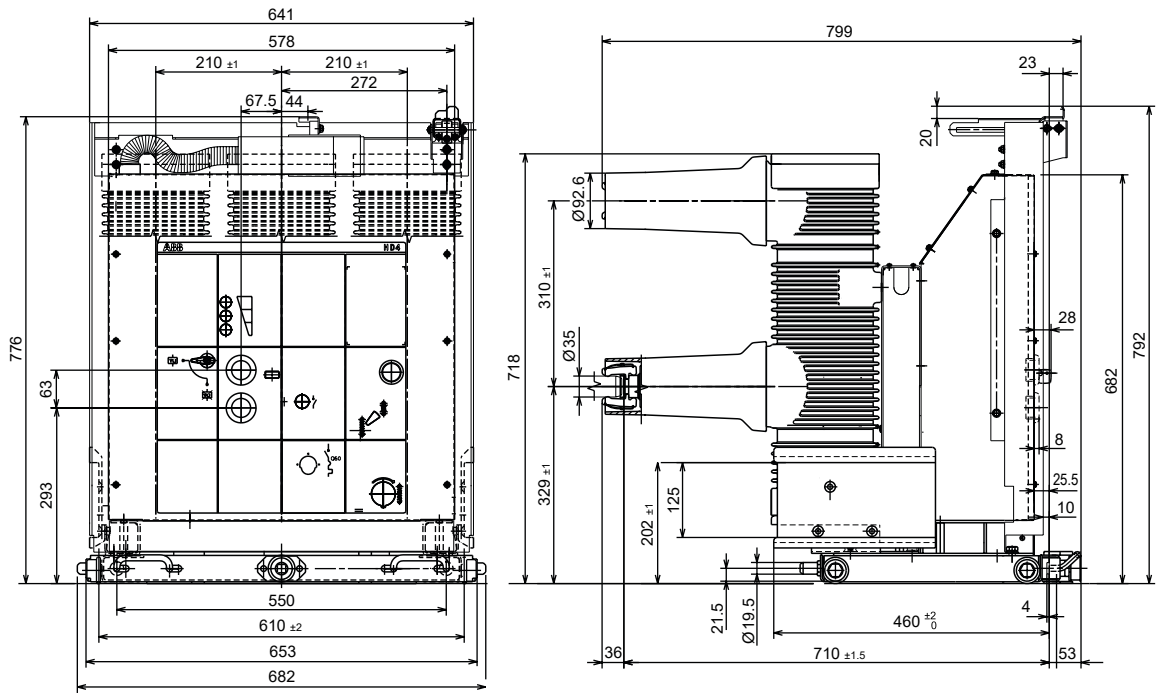

HD4/P withdrawable circuit-breakers for UniGear type ZS1 switchgears

HD4/P

TN	7355 (*)
Ur	24 kV
Ir	1600 A
Isc	16 kA
	20 kA
	25 kA
	31.5 kA

(*) Also suitable for PowerCube PB5.

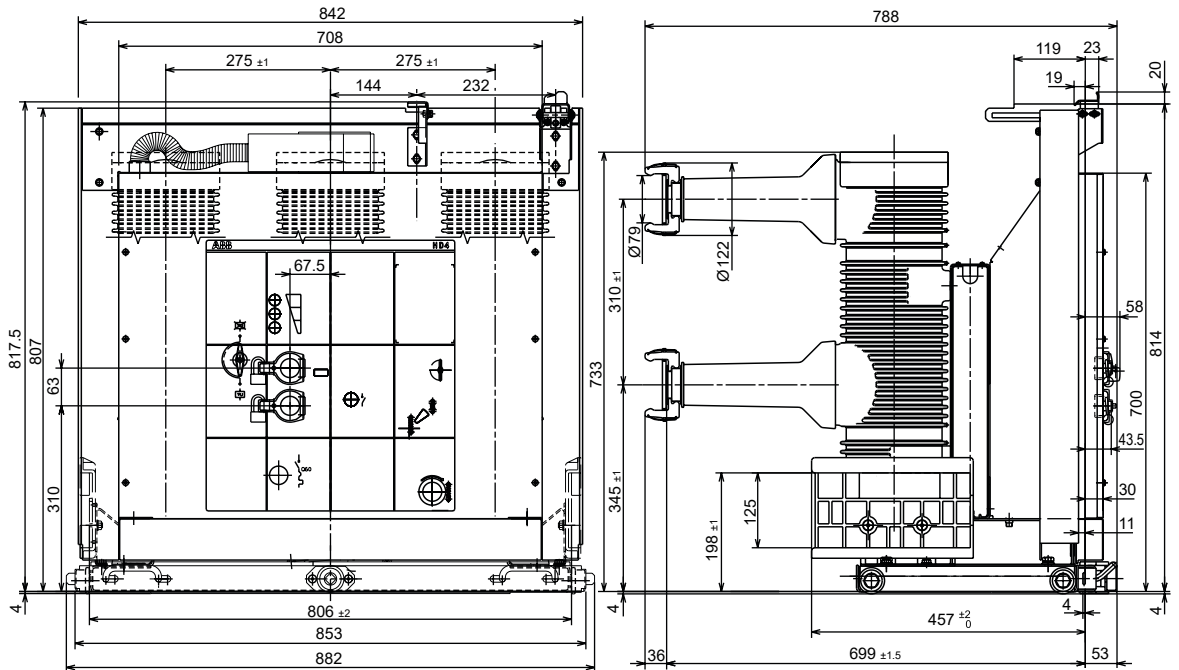

HD4/P withdrawable circuit-breakers for UniGear type ZS1 switchgears

HD4/P

TN	7356 (**)
Ur	24 kV
Ir	2000 A
Isc	16 kA
	20 kA
	25 kA
	31.5 kA

HD4/P

TN	7356 (**)
Ur	24 kV
Ir	2500 A (*)
Isc	20 kA
	25 kA
	31.5 kA

(*) 2500 A with forced ventilation; 2300 A with natural ventilation.

(**) Also suitable for PowerCube PB5.

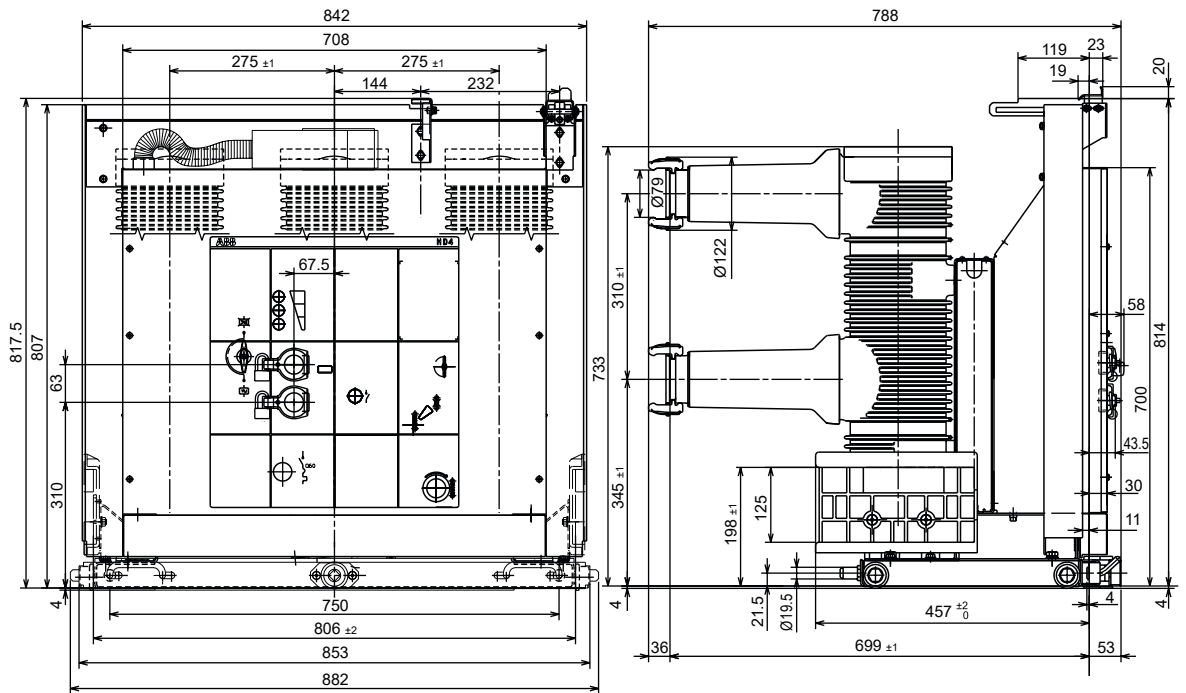

HD4/W withdrawable circuit-breakers for PowerCube modules

HD4/W

TN	7229
Ur	12 kV
	17.5 kV
Ir	630 A
	1250 A
Isc	31.5 kA

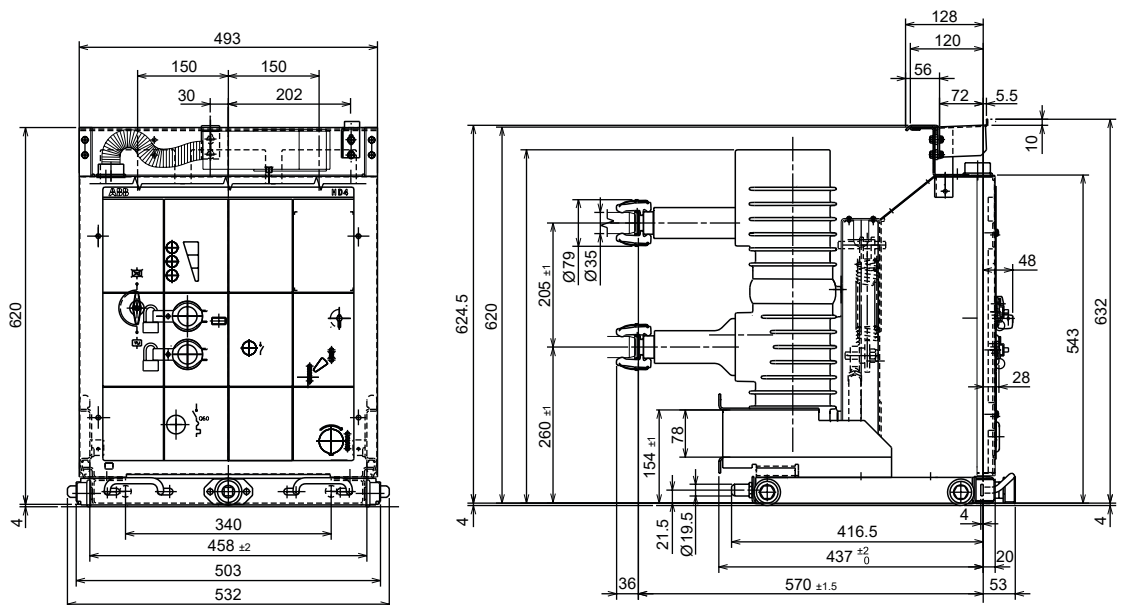

HD4/W withdrawable circuit-breakers for PowerCube modules

HD4/W	
TN	7182
Ur	12 kV
	17.5 kV
Ir	630 A
	1250 A
Isc	16 kA
	25 kA
	31.5 kA

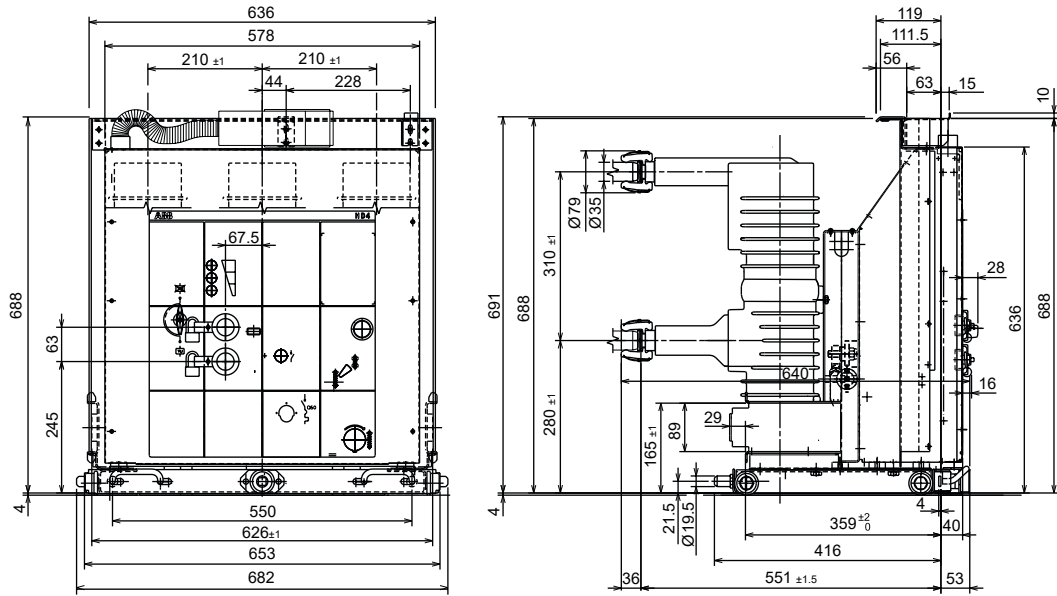

HD4/W withdrawable circuit-breakers for PowerCube modules

HD4/W	
TN	7421
Ur	12 kV
	17.5 kV
Ir	1250 A
Isc	40 kA
	50 kA

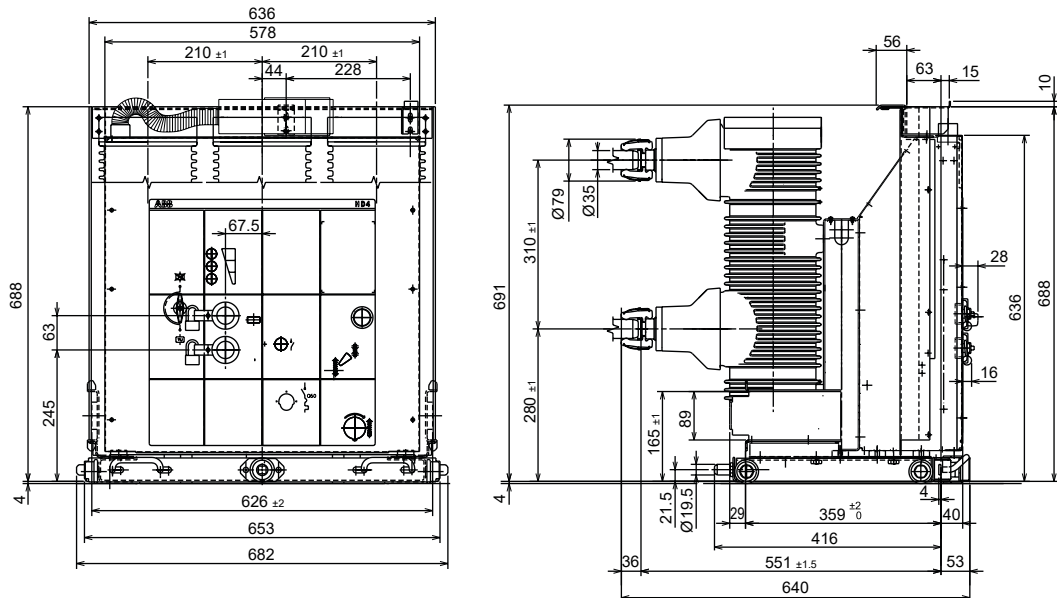

HD4/W withdrawable circuit-breakers for PowerCube modules

HD4/W

TN	7239
Ur	12 kV
	17.5 kV
Ir	1600 A
	2000 A
Isc	16 kA
	25 kA
	31.5 kA

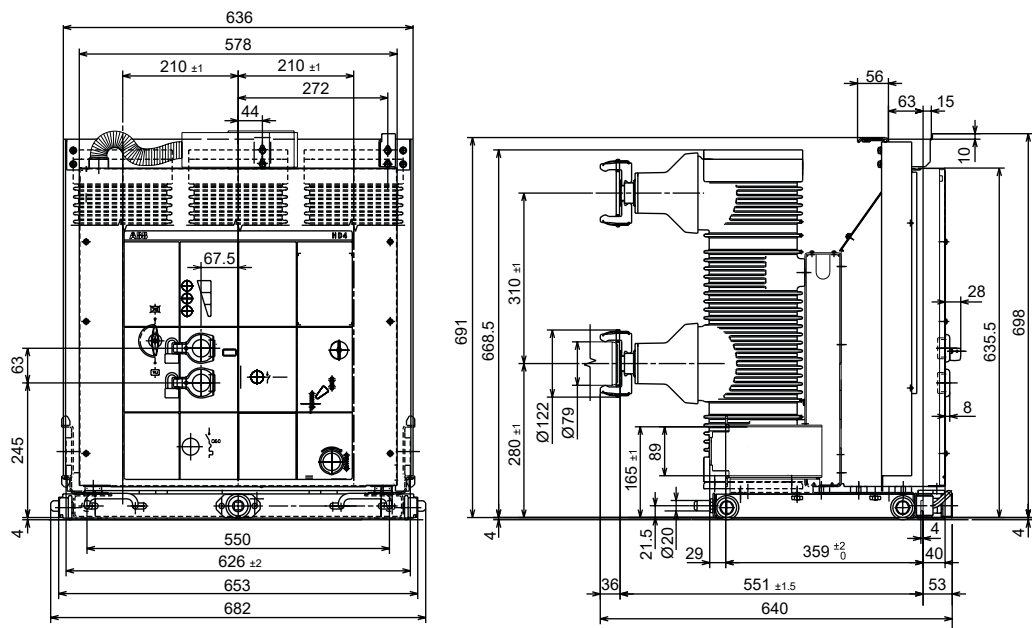

HD4/W withdrawable circuit-breakers for PowerCube modules

HD4/W

TN	1VCD000053
Ur	12 kV
	17.5 kV
Ir	3150 A
Isc	31.5 kA
	40 kA
	50 kA

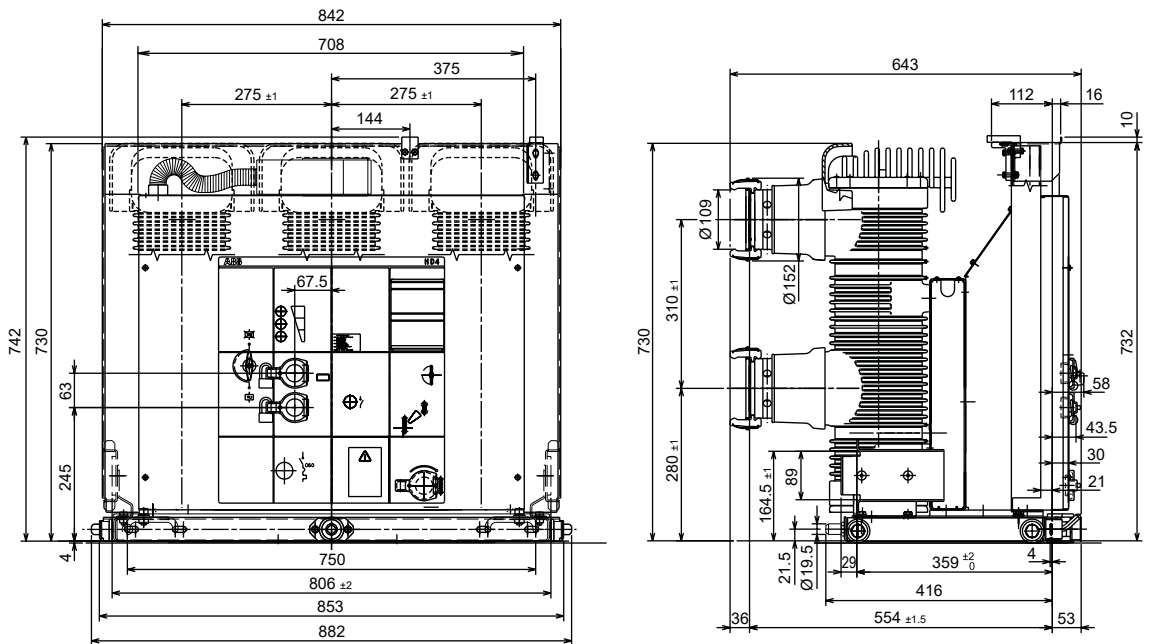

HD4/W withdrawable circuit-breakers for PowerCube modules

HD4/W	
TN	7183
Ur	24 kV
Ir	630 A
Isc	1250 A
	16 kA
	20 kA
	25 kA

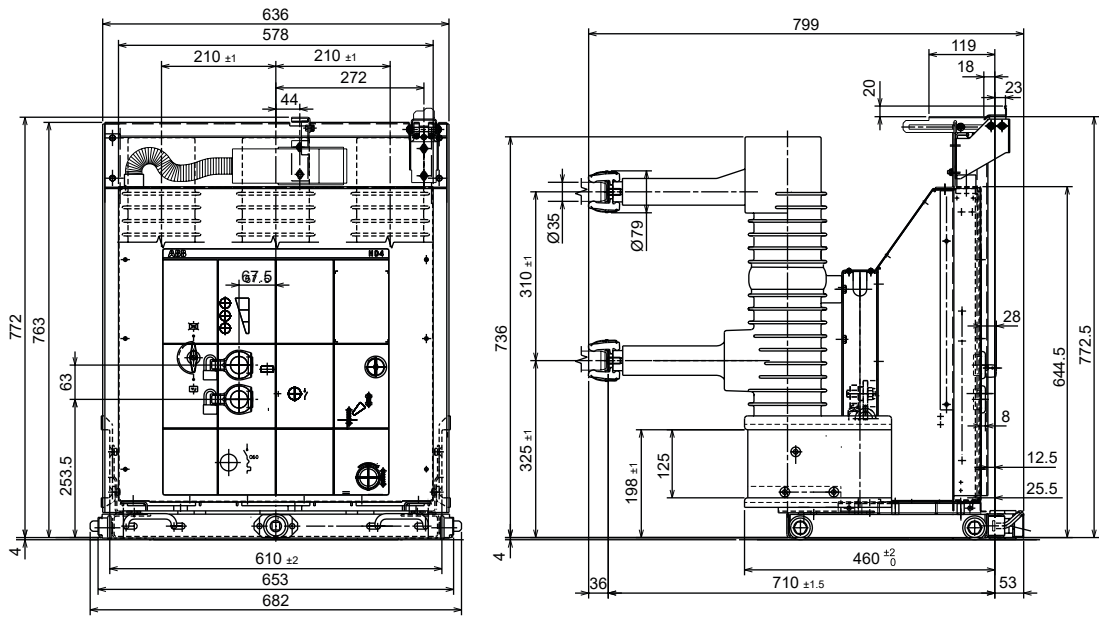

Withdrawable circuit-breakers HD4/W for UniGear type ZS2 switchgear and for PowerCube module

HD4/W	
TN	7402
Ur	36 kV
Ir	1250 A
Isc	20 kA
	25 kA

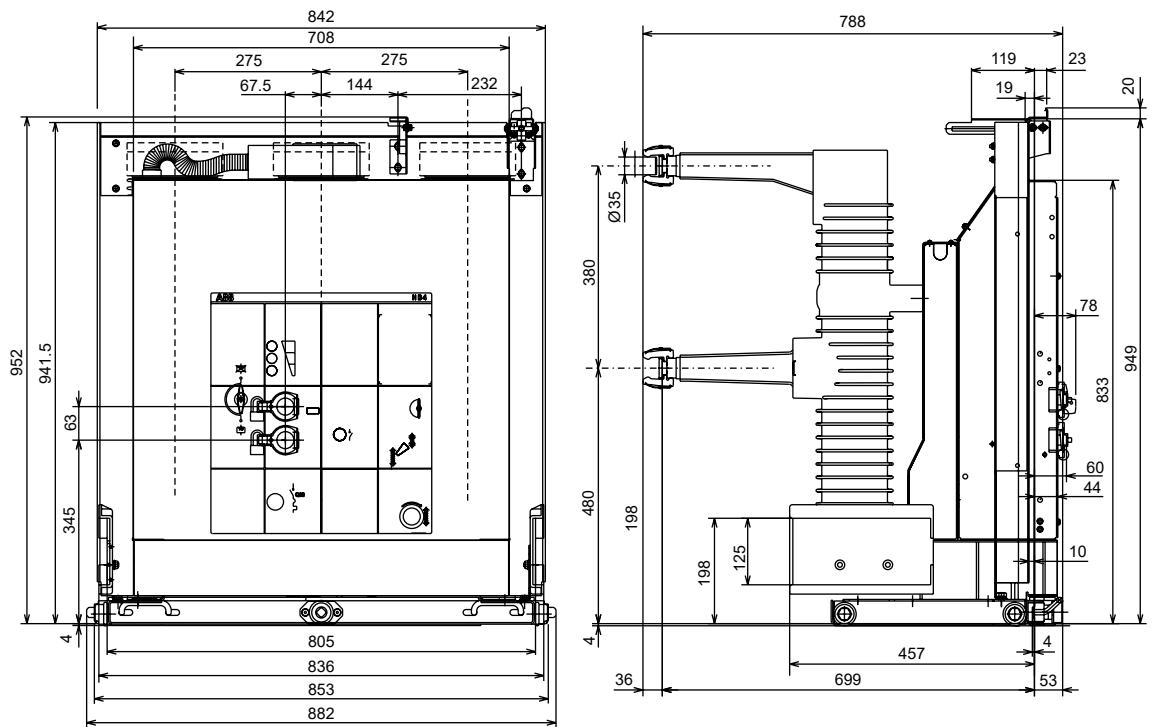

Withdrawable circuit-breakers HD4/W for UniGear type ZS2 switchgear and for PowerCube module

HD4/W

TN	7316
Ur	36 kV
Ir	1250 A
Isc	31.5 kA

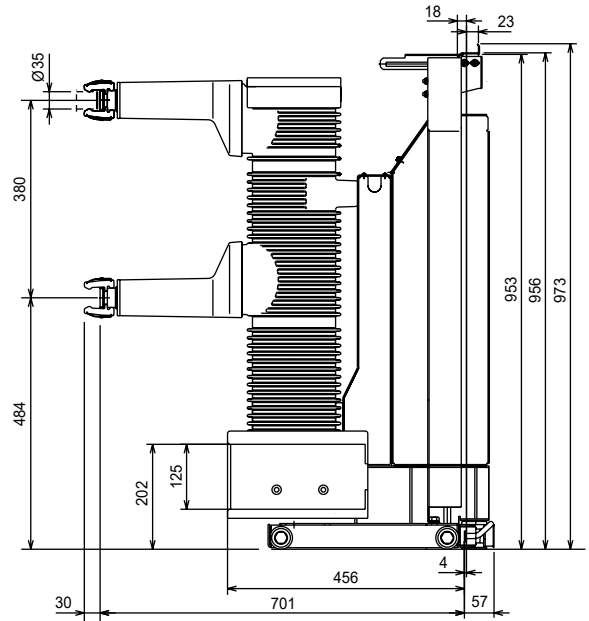
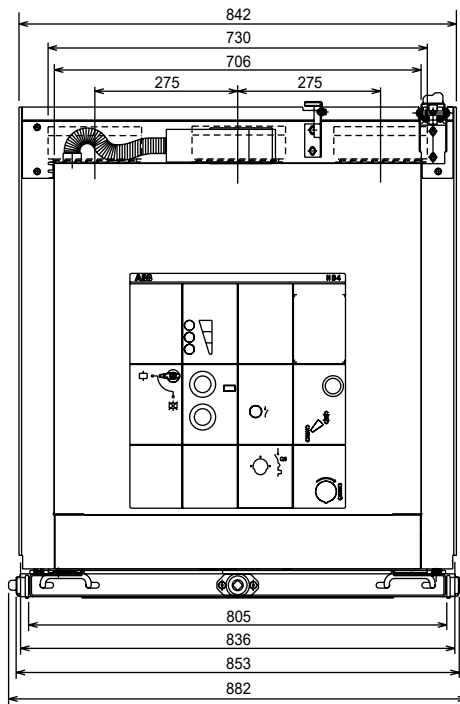

Withdrawable circuit-breakers HD4/W for UniGear type ZS2 switchgear and for PowerCube module

HD4/W

TN	7317
Ur	36 kV
Ir	1600 A
	2000 A
	2500 A (*)
Isc	20 kA
	25 kA
	31.5 kA

(*) With forced ventilation.

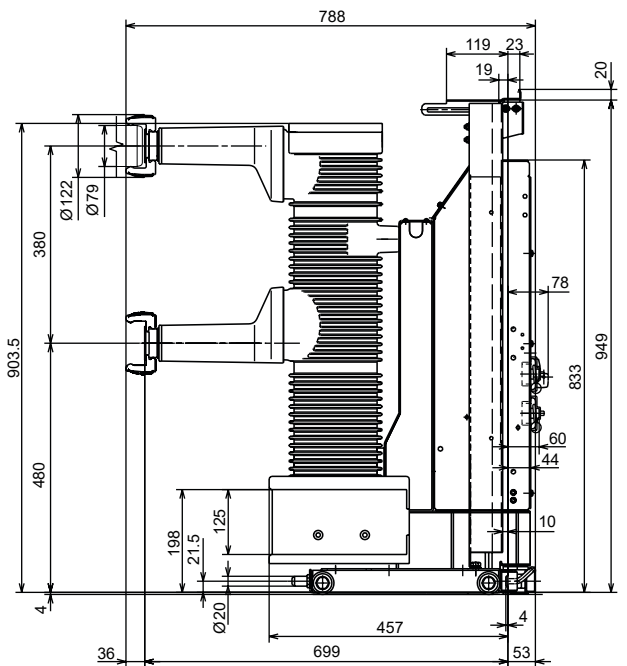
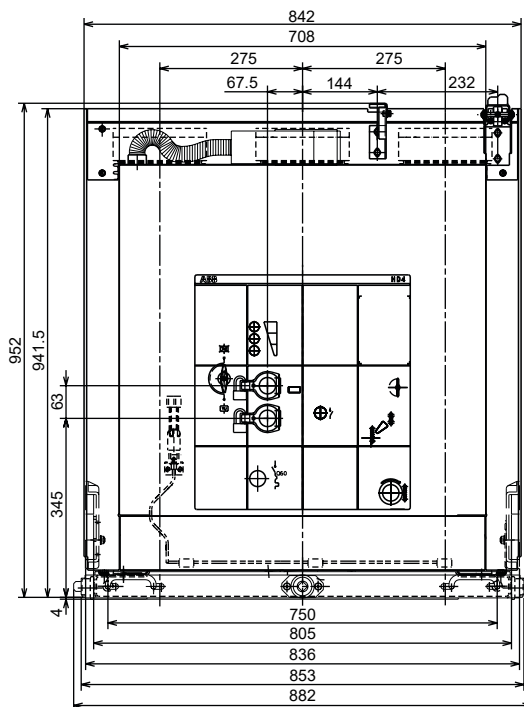

HD4/Z withdrawable circuit-breakers for UniGear type ZS3.2 - 40.5 kV switchgears

HD4/Z/40.5 kV

TN	7227
Ur	40.5 kV
I _r	1250 A
	1600 A
	2000 A
	2500 A (*)
I _{sc}	25 kA
	31.5 kA

(*) With natural ventilation in loose enclosure type Powerbloc; with forced ventilation in switchgear type ZS3.2.

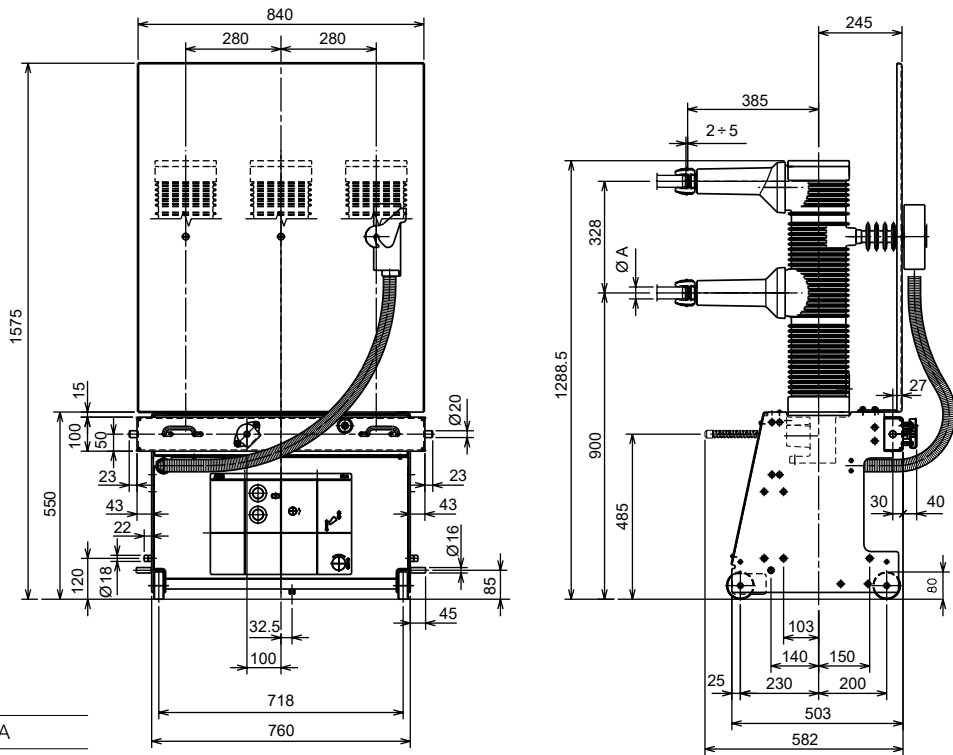

	Ø A
1250-1600 A	35 mm
2000-2500 A (*)	79 mm

HD4/US withdrawable circuit-breakers for UniSwitch (CBW) and UniMix (P1/E) switchgears

HD4/US 24 kV

TN	1VCD000046
Ur	24 kV
I _r	630 A
	1250 A
I _{sc}	16 kA
	20 kA
	25 kA (*)

(*) Only for UniMix P1/E

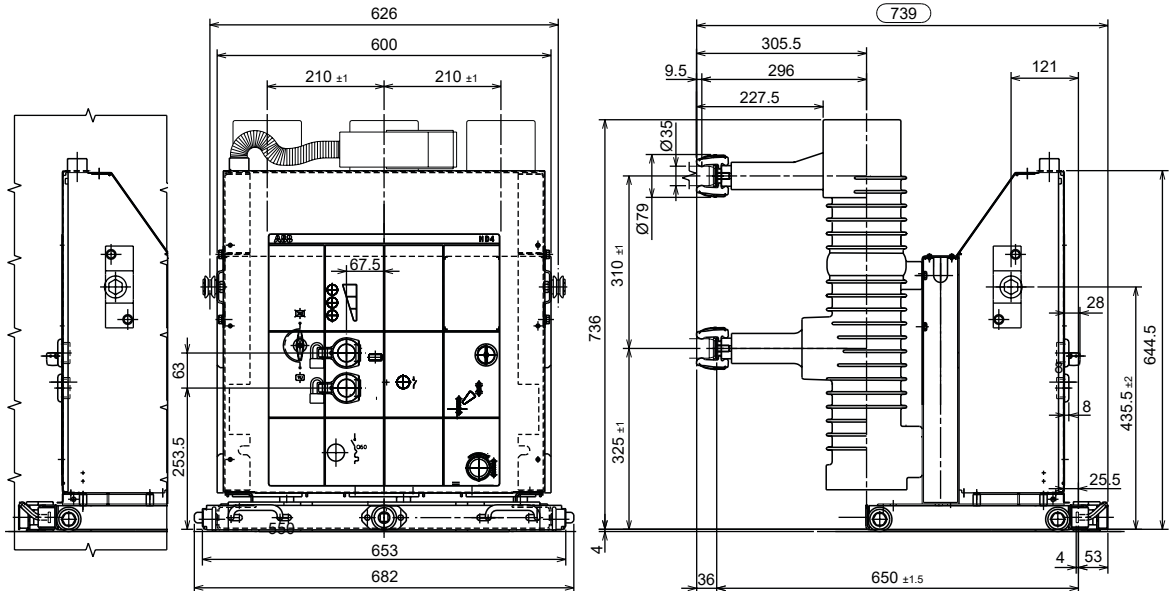

8. Putting into service

8.1. General procedures



All the operations regarding putting into service must be carried out by ABB personnel or customer personnel who are suitably qualified and have an in-depth knowledge of the apparatus and installation.

If the operations are prevented, do not force the mechanical interlocks, but check that the operation sequence is correct.

The operating forces which can be applied are indicated in paragraph 6.3.

Before putting the circuit-breaker into service carry out the following operations:

- check the tightness of the power connections on the circuit-breaker terminals;
- establish the setting of the direct solid-state overcurrent release (if provided);
- check that the value of the supply voltage for the auxiliary circuits is within 85% and 110% of the rated voltage of the electrical devices;
- check that no foreign body, such as packaging, has got into the moving parts;
- check that air circulation in the circuit-breaker installation site is adequate so that there is no danger of overheating;
- carry out the checks indicated in the following table:

Subject of the inspection		Procedure	Positive check
1	Insulation resistance.	Medium voltage circuits With a 2500 V Megger, measure the insulation resistance between phases and exposed conductive part of the circuit.	The insulation resistance should be at least 50 M Ω and, in any case, constant in time.
		Auxiliary circuits With a 500 V Megger (installed equipment permitting) measure the insulation resistance between the auxiliary circuits and the exposed conductive part.	The insulation resistance should be a few M Ω and, in any case, constant in time.
2	Auxiliary circuits.	Check that the connections to the control circuit are correct; proceed with relative supply.	Normal switchings and signalings
3	Manual operating mechanism.	Carry out a few closing and opening operations (see chap. 6). N.B. Supply the u/v release and the locking magnet on the operating mechanism at the relative rated voltage (if provided).	The operations and relative signals occur correctly.
4	Motor operator (if provided)	Supply the geared motor for spring charging at the relative rated voltage.	The springs are charged correctly. The signals are correct. The geared motor cuts off when the springs are charged.
		Carry out a few closing and opening operations. N.B. Supply the undervoltage release and the locking magnet on the operating mechanism at the relative rated voltage (if provided).	The geared motor recharges the springs after each closing operation.
5	Undervoltage release (if provided).	Supply the undervoltage release at the relative rated voltage and carry out the circuit-breaker closing operation.	The circuit-breaker closes correctly. The signals are correct.
		Disconnect the power supply to the release.	The circuit-breaker opens. The signal changes over.
6	Shunt opening release and additional shunt opening release (if provided).	Close the circuit-breaker. Supply the shunt opening release at the relative rated voltage.	The circuit-breaker opens correctly. The signals are correct.
7	Shunt closing release (if provided).	Open the circuit-breaker. Supply the shunt closing release at the relative rated voltage.	The circuit-breaker closes correctly. The signals are correct.
8	Key lock (if provided).	Open the circuit-breaker. Turn the key and remove it. Attempt the circuit-breaker closing operation.	Neither manual nor electric closing takes place.
		Insert the key again and turn it 90°. Carry out the closing operation.	Both electric and manual closing take place correctly; in this position the key cannot be removed.
9	Locking electromagnet (YL1) (if provided).	With the circuit-breaker open, springs charged and locking electromagnet not supplied, attempt to close the circuit-breaker both manually and electrically.	Closing is not possible.
10	Auxiliary contacts in the operating mechanism.	Insert the auxiliary contacts into suitable signalling circuits. Carry out a few closing and opening operations.	Signals occur correctly.

Subject of the inspection		Procedure	Positive check
11	Locking electromagnet on the circuit-breaker truck (YL2) (if provided).	With the circuit-breaker open in the isolated for test position and the locking electromagnet not supplied, attempt to connect the circuit-breaker.	Connection is not possible.
		Supply the locking electromagnet and carry out the connection operation.	Connection takes place correctly.
12	Auxiliary transmitted contacts for indicating that the circuit-breaker is connected, isolated (CBE or PowerCube enclosures).	Insert the auxiliary contacts into suitable signalling circuits. With the circuit-breaker inside the enclosure carry out a few translation operations from the isolated for test position to the connected position. Put the circuit-breaker in the withdrawn position.	The signals of the relative operations occur correctly.
13	Electromechanical locking device (if provided) (CBE or PowerCube enclosures).	With no supply to the locking device try to rack-in the circuit-breaker into the enclosure. Supply the locking device at the relative rated voltage. Carry out the racking-in operation.	Racking-in is not possible. Racking-in is possible.

9. Periodical checking



Before carrying out any operation, make sure that the operating mechanism springs are discharged and that the apparatus is in the open position.

9.1. General

During normal service, the circuit-breakers are maintenance-free. The frequency and sort of inspections basically depend on the service conditions. Various factors must be taken into account: frequency of operations, interrupted current values, relative power factor and the installation ambient.

The following paragraph gives the checking programme table, showing the relevant time intervals.

As far as the time interval between these operations is concerned, it is advisable to comply with specifications given in the table, at least during the first check. On the basis of the results obtained during the periodic inspections, set the optimal time limits for carrying out the following operations.

9.2. Checking programme

Checking operation	Time interval	Criteria
1 Carry out five mechanical opening closing operations.	1 year.	The circuit-breaker must operate normally without stopping in intermediate positions
2 Visual inspection of the poles (parts in resin).	1 year or 5,000 operations.	The parts in resin must be free of any accumulation of dust, dirt, cracks, discharges or traces of surface discharges.
3 Visual inspection of the operating mechanism and transmission.	1 year or 5,000 operations.	The elements must be free of any deformation. Screws, nuts, bolts, etc. must be tight.
4 Visual inspection of the isolating contacts.	5 year or 5,000 operations.	The isolating contacts must be free of any deformation or erosion. Lubricate the contact elements with industrial vaseline greaseindustriale.
5 Measuring the insulation resistance.	5 year or 5,000 operations.	See para. 8.1. point 2.
6 Checking interlock operation.	5 year.	The interlocks provided must operate correctly.

After 10,000 operations or after 10 years, for installation in polluted and aggressive ambients, it is advisable to contact an ABB service center to have the circuit-breaker checked.

10. Maintenance operations



Maintenance must only be carried out by ABB personnel or in any case by suitably qualified customer personnel who have in-depth knowledge of the apparatus (IEC 62271-1 para 10.4.2). Should the maintenance be carried out by the customer's personnel, responsibility for any interventions lies with the customer.

Replacement of any parts not included in the "List of spare parts/accessories" must only be carried out by ABB personnel.

In particular:

- Complete pole with bushings/connections
- Operating mechanism
- Closing spring unit
- Opening spring.

11. Indications for handling apparatus with SF6

SF6 in its pure state is an odourless, colourless, non-toxic gas with a density about six times higher than air. For this reason, although it does not have any specific physiological effects, it can produce the effects caused by lack of oxygen in ambients saturated with SF6.

During the interruption phase of the circuit-breaker, an electric arc is produced which decomposes a very small amount of SF6. The decomposition products remain inside the poles and are absorbed by special substances which act as molecular sieves. The probability of contact with decomposed SF6 is extremely remote, and its presence in small quantities (1-3 ppm) is immediately noticeable because of its sour and unpleasant smell. In this case, the room must be aired before anybody enters it.

The strong infrared absorption of SF6 and its long lifetime in the environment are the reasons for its high Global Warming Potential (GWP) which is 22 200 higher than CO2, according to the Third Assessment Report.

The GWP is calculated over a time period of 100-years warming potential of 1 kg of a gas referred to 1 kg of CO2. Its overall contribution to the global greenhouse gas effect from all applications amounts to approximately 0,2% overall. However, the GWP of SF6 alone is not adequate to measure the environmental impact of electric power equipment based on SF6 technology.

The environmental impact of any specific application should be evaluated and/or compared using the Life Cycle Assessment – LCA approach as regulated by ISO 14040.

The Electric Industry utilises SF6 in a closed cycle, banking it e.g. in gas insulated substations (GIS), medium-voltage and high-voltage gas circuit breakers (GCB), high-voltage gas insulated lines (GIL), gas insulated voltage transformers (GVT). In Asia, significant quantities of SF6 are banked in gas insulated power transformers (GIT) as well.

The Electric Industry is reported as the most important user of SF6, worldwide. In spite of being the most important user of SF6, the Electric Industry is a low contributor to the global emission of SF6, far below to other industries or users with “open application” of the gas. However, its importance as source substantially varies from region to region and from country to country, depending on the SF6 handling procedures adopted, the tightness of the electric power equipment and the amount of gas banked in electric equipment.

For info about Life Cycle Assessment of apparatus, see document (1VCP000264).

To dispose of the SF6 gas, please contact the ABB Assistance Service (see contact persons at <http://www.abb.com/ServiceGuide/alphabetical.aspx>) as this operation must be done only by trained and qualified personal; on request are available specific instructions for the evacuation of the SF6 gas from the apparatuses.

The volume of SF6 in each apparatus is indicated on the nameplate.

12. Spare parts and accessories



All assembly operations of spare parts/accessories regarding installation, putting into service, service and maintenance must be carried out by ABB personnel or suitably qualified customer personnel with in-depth knowledge of the apparatus (IEC 62271-1 para. 10.4.2). Should the maintenance be carried out by the customer's personnel, responsibility for any interventions lies with the customer.

Before carrying out any operation, check that the circuit-breaker is open, the springs discharged and that there is no voltage (medium voltage circuit and auxiliary circuits).

To order accessories or spare parts, please refer to the commercial ordering codes given in the technical catalogue and always indicate:

- circuit-breaker type
- circuit-breaker rated voltage
- circuit-breaker rated thermal current
- circuit-breaker breaking capacity
- circuit-breaker serial number
- rated voltage of any electrical accessories.

For availability and ordering of spare parts please contact our Service department.

12.1. List of spare parts

- Shunt opening release
- Additional shunt opening release
- Undervoltage release
- Contact signalling undervoltage release energised/de-energised
- Undervoltage release delay device
- Mechanical exclusion device for undervoltage release
- Shunt closing release
- Spring charging geared motor with electric signalling of springs charged
- Geared motor thermomagnetic protection circuit-breaker
- Contact signalling geared motor protection circuit-breaker open/closed
- Contact signalling closing springs charged/discharged
- Transient contact with momentary closure during circuit-breaker opening
- Auxiliary circuit-breaker contacts
- Locking electromagnet on operating mechanism
- Position contact of withdrawable truck
- Contacts signalling connected/isolated
- Opening solenoid
- Key lock in open position
- Isolation interlock with door
- Protection for opening pushbutton
- Protection for closing pushbutton
- Locking electromagnet on withdrawable truck
- Sliding earthing contact of withdrawable truck
- Opening/closing knob
- Set of six tulip contacts
- SF6 gas pressure monitoring device.

For more information please contact:

ABB S.p.A.

Power Products Division

Unità Operativa Sace-MV

Via Friuli, 4

I-24044 Dalmine

Tel.: +39 035 6952 111

Fax: +39 035 6952 874

E-mail: info.mv@it.abb.com

www.abb.com

The data and illustrations are not binding. We reserve the right to make changes without notice in the course of technical development of the product.

© Copyright 2015 ABB. All rights reserved.