

# Combined Overcurrent and Earth-fault Relay

# SPAJ 141 C

## Product Guide





---

## Features

- Three-phase, low-set phase overcurrent unit with definite time or inverse definite minimum time (IDMT) characteristic
- Three-phase, high-set phase overcurrent unit with instantaneous or definite time operation
- Low-set sensitive earth-fault unit with definite time characteristic
- High-set earth-fault unit with instantaneous or definite time operation
- Built-in circuit-breaker failure protection
- Two heavy-duty and four signal output relays
- Output relay matrix allowing start or trip signals from the protection stages to be routed to the desired output relay
- Local display of measured and set values and data recorded at the moment of a fault
- Reading and writing of setting values either via local display and front panel push-buttons or from higher-level systems over the serial interface and the fibre-optic bus
- Self-supervision system continuously monitoring the operation of the electronics and the microprocessor

---

## Application

The combined overcurrent and earth-fault relay SPAJ 141 C is intended to be used for the selective short-circuit and earth-fault protection of radial feeders in solidly earthed, resistance earthed or impedance earthed power systems. The integrated protection relay includes an overcurrent unit and an earth-fault unit with flexible tripping and signalling facilities. The overcurrent and earth-fault relays can also be used for other applications requiring single-, two-, or three-phase

overcurrent protection and earth-fault protection. The combined overcurrent and earth-fault relay includes a circuit-breaker failure protection unit.

The combined overcurrent and earth-fault relay SPAJ 141 C is part of ABB's Distribution Automation concept extending ABB's solution for the control and management of electric power systems.

## Design

The combined overcurrent and earth-fault relay is a secondary relay to be connected to the current transformers of the object to be protected. The three-phase overcurrent unit and the earth-fault unit continuously measure the phase currents and the neutral current of the object. On detection of a fault the relay starts, trips the circuit breaker, provides an alarm signal, records fault data, etc., in accordance with the requirements of the application and the relay configuration.

When the phase current exceeds the set start current of the low-set stage  $I_{>}$ , the overcurrent unit starts and, after a preset start time, it delivers a start signal. When the set operate time, at definite time operation, or the calculated operate time, at inverse time operation, elapses, the overcurrent unit operates. In the same way, the high-set stage  $I_{>>}$  of the overcurrent unit starts when the set start current is exceeded and delivers a start signal after the preset (~40 ms) start time. When the set operate time has elapsed, the overcurrent unit operates.

When the earth-fault current exceeds the set start current of the low-set stage  $I_{0>}$ , the earth-fault unit starts and, after the preset start time, it delivers a start signal. When the set operate time has elapsed, the earth-fault unit operates. In the same way, the high-set stage  $I_{0>>}$  of the earth-fault unit starts, when the set start current is exceeded, and delivers a start signal after the preset (~50 ms) start time. Once the set operate time has elapsed, the earth-fault unit operates.

The low-set stage of the overcurrent unit may be given definite time or inverse definite minimum time (IDMT) characteristic. The IDMT characteristic includes six time/current curve sets. Four of the curve sets comply with the BS 142 and IEC 255 and are named "Normal inverse", "Very inverse", "Extremely inverse" and "Long-time inverse". The two additional inverse time curve sets comply with ABB standards and are called "RI" and "RXIDG".

By appropriate configuration of the output relay matrix, the start signals of the overcurrent and earth-fault units are obtained as contact functions. The start signals can be used for blocking co-operating protection relays, and for signalling.

The relay includes one external binary input, which is controlled by an external control voltage. The function of the control input is determined by a selector switch in the protection relay module. The control input can be used for blocking the operation of one or more protection stages, for resetting a latched output relay in the manual reset mode or for switching between main and second setting banks.

## Data communication

The relay is provided with a serial interface on the rear panel. By means of a bus connection module type SPA-ZC 17 or SPA-ZC 21 the relay can be connected to the fibre-optic SPA bus. The bus connection module type SPA-ZC 21 is powered from the host relay, whereas the bus connection module SPA-ZC 17 is provided with a built-in power unit, which can be fed from an external secured power source. The relay communicates with higher-level data acquisition and control systems over the SPA bus.

## Self-supervision

The relay incorporates a sophisticated self-supervision system with auto-diagnosis, which increases the availability of the relay and the reliability of the system. The self-supervision system continuously monitors the hardware and the software of the relay. The system also supervises the operation of the auxiliary supply module and the voltages generated by the module.

When a permanent internal relay fault is detected, the IRF indicator on the relay front panel is lit. At the same time the output relay of the self-supervision system operates and a fault message is transmitted to the higher-level system over the serial bus. Further, in most fault situations, a fault code is shown in the display of the protection relay module. The fault code indicates the type of the fault that has been detected.

## Auxiliary supply voltage

The auxiliary supply of the relay is obtained from an internal plug-in type power supply module. Two auxiliary power module versions are available: type SPTU 240R1 for the supply voltage range 80...265 V ac/dc and type SPTU 48R1 for the supply voltage range 18...80 V dc. The power supply module forms the internal voltages required by the protection relay and the I/O module.

**Technical data**

**Table 1: Energizing inputs, overcurrent unit**

Terminals		1-3, 4-6, 7-9	1-2, 4-5, 7-8
Rated current $I_n$		1 A	5 A
Thermal withstand capability	continuously	4 A	20 A
	for 10 s	25 A	100 A
	for 1 s	100 A	500 A
Dynamic current withstand capability	Half-wave value	250 A	1250 A
Input impedance		<100 m $\Omega$	<20 m $\Omega$
Rated frequency $f_n$ , according to order		50 Hz or 60 Hz	

**Table 2: Energizing inputs, earth-fault unit**

Terminals		25-28	25-27
Rated current $I_n$		0.2 A	1 A
Thermal withstand capability	continuously	1.5 A	4 A
	for 10 s	7 A	25 A
	for 1 s	40 A	100 A
Dynamic current withstand capability	Half-wave value	100 A	250 A
Input impedance		<750 m $\Omega$	<100 m $\Omega$
Rated frequency $f_n$ , according to order		50 Hz or 60 Hz	

**Table 3: Output contact ratings**

Type of contact		Tripping	Signalling
Terminals		65-66, 74-75	70-71-72, 68-69, 77-78, 80-81
Rated voltage		250 V ac/dc	
Continuous carry		5 A	5 A
Make and carry for 0.5 s		30 A	10 A
Make and carry for 3 s		15 A	8 A
Breaking capacity for dc, when the control/signalling circuit time constant $L/R \leq 40$ ms, at the control voltages	220 V dc	1 A	0.15 A
	110 V dc	3 A	0.25 A
	48 V dc	5 A	1 A

Technical data (cont'd)

**Table 4: Control, communication and power supply**

External control input	Terminals	10-11		
	Control voltage level	18...265 V dc or 80...265 V ac		
	Current drain at activated input	2...20 mA		
Data communication	Transmission mode	Fibre-optic serial bus		
	Data code	ASCII		
	Selectable data transfer rates	4800 or 9600 Bd		
	Bus connection module, powered from the host relay	for plastic core cables	SPA-ZC 21BB	
		for glass fibre cables	SPA-ZC 21MM	
	Bus connection module, powered from the host relay or from an external power source	for plastic core cables	SPA-ZC 17BB	
for glass fibre cables		SPA-ZC 17MM		
Auxiliary supply modules	Power supply and I/O modules, rated voltages and operative range	SPTU 240R1	110/120/230/240 V ac, 110/125/220 V dc, 80...265 V ac/dc	
		SPTU 48R1	24/48/60 V dc, 18...80 V dc	
	Power consumption	under quiescent conditions	~4 W	
		under operating conditions	~6 W	

**Table 5: Relay module SPCJ 4D24, overcurrent unit**

Features	Stage I>	Stage I>>	
Start current	at definite time	$0.5...5.0 \times I_n$	$0.5...40.0 \times I_n$ or $\infty$
	at inverse time	$0.5...2.5 \times I_n$	–
Start time, typically	50 ms	40 ms	
Operate time at definite time characteristic	0.05...300 s	0.04...300 s	
Time/current characteristic at inverse time mode	Extremely inverse Very inverse Normal inverse Long-time inverse RI type inverse RXIDG type inverse	–	
Time multiplier k	0.05...1.0	–	
Reset time, typically	40 ms	40 ms	
Retardation time	<30 ms		
Reset ratio, typically	0.96		
Operate time accuracy at definite time mode	$\pm 2\%$ of set value or $\pm 25$ ms		
Accuracy class index E at inverse time mode	5	–	
Operation accuracy	$\pm 3\%$ of set value	$\pm 3\%$ of set value	

**Table 6: Relay module SPCJ 4D24, earth-fault unit**

Features	Stage I <sub>0</sub> >	Stage I <sub>0</sub> >>
Start current	1...25% of $I_n$	2...200% of $I_n$ or $\infty$
Start time, typically	60 ms	40 ms
Operate time at definite time characteristic	0.05...300 s	0.05...300 s
Reset time, typically	40 ms	40 ms
Reset ratio, typically	0.96	0.96
Operate time accuracy	$\pm 2\%$ of set value or $\pm 25$ ms	
Operation accuracy	$\pm 3\%$ of set value	$\pm 3\%$ of set value

Technical data (cont'd)

**Table 7: Tests and standards**

Test voltages	Dielectric test voltage (IEC 60255-5)	2.0 kV, 50 Hz, 1 min
	Impulse test voltage (IEC 60255-5)	5 kV, 1.2/50 $\mu$ s, 0.5 J
	Insulation resistance (IEC 60255-5)	>100 M $\Omega$ , 500 V dc
Interference tests	High-frequency (1 MHz) disturbance test (IEC 60255-22-1), common mode	2.5 kV
	High-frequency (1 MHz) disturbance test (IEC 60255-22-1), differential mode	1.0 kV
	Fast transients (IEC 60255-22-4, class III and IEC 61000-4-4), power supply inputs	4 kV, 5/50 ns
	Fast transients (IEC 60255-22-4, class III and IEC 61000-4-4), other inputs	2 kV, 5/50 ns
	Electrostatic discharge (IEC 60255-22-2 and IEC 61000-4-2), air discharge	8 kV
	Electrostatic discharge (IEC 60255-22-2 and IEC 61000-4-2), contact discharge	6 kV
	Environmental conditions	Service temperature range
	Transport and storage temperature range (IEC 60068-2-8)	-40...+70°C
	Damp heat test (IEC 60068-2-3)	<95%, +40°C, 96 h
	Degree of protection by enclosure when panel mounted	IP 54
	Weight	~3.5 kg

Block diagram

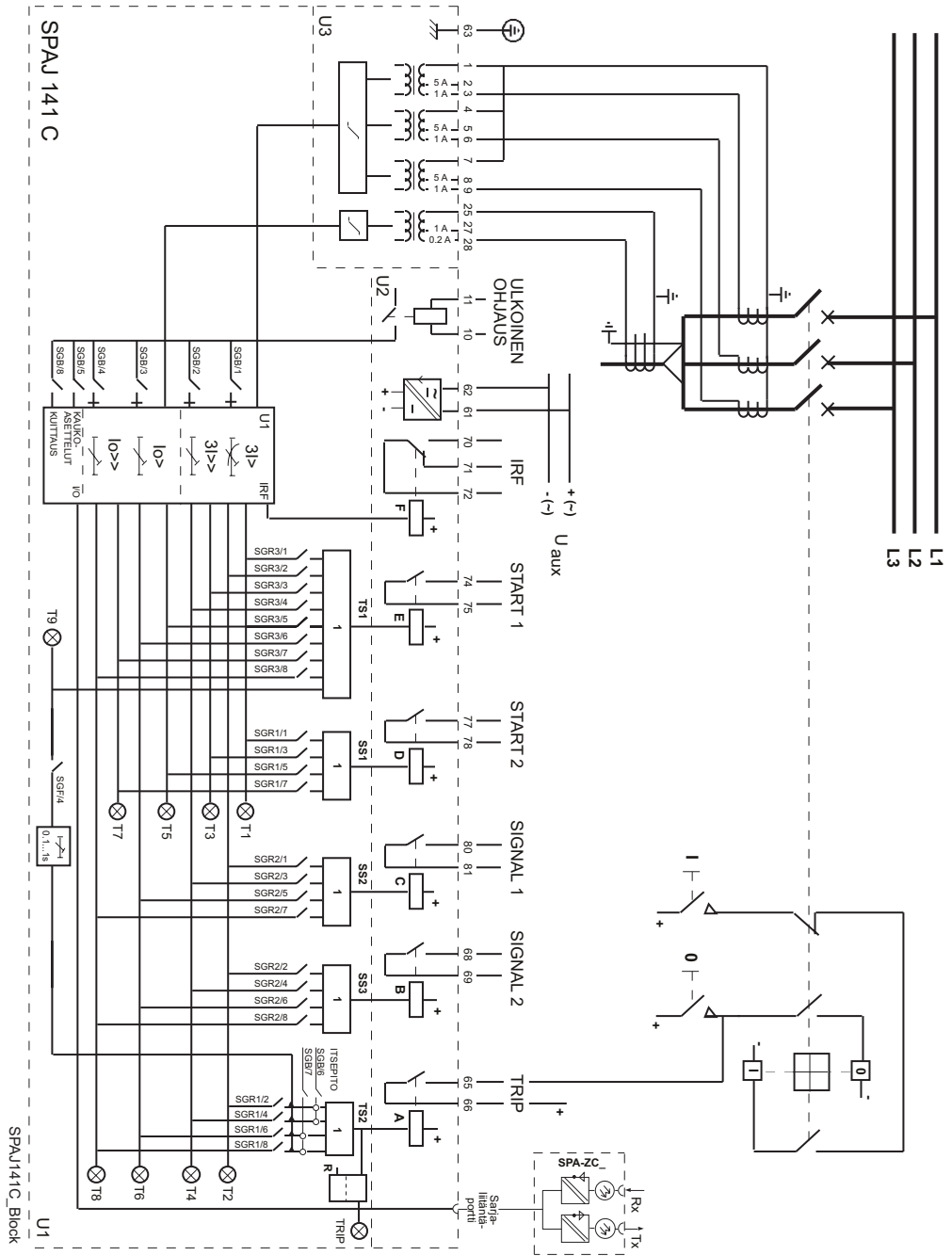

Fig. 1 Block diagram and sample connection diagram

SPAJ141\_block



Mounting and dimensions

Flush mounting

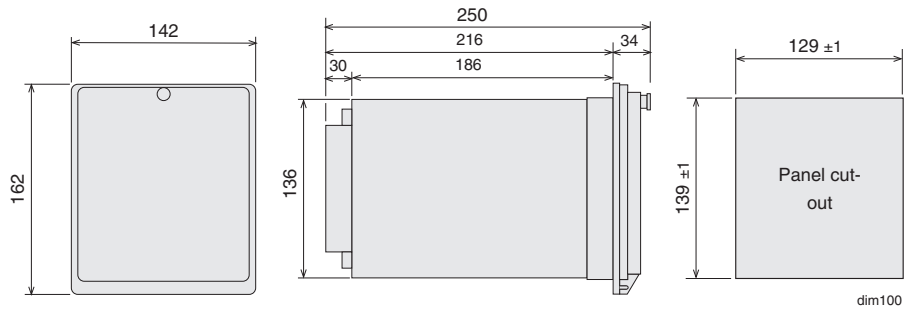

Fig. 2 Flush-mounting relay case (dimensions in mm)

Semi-flush mounting

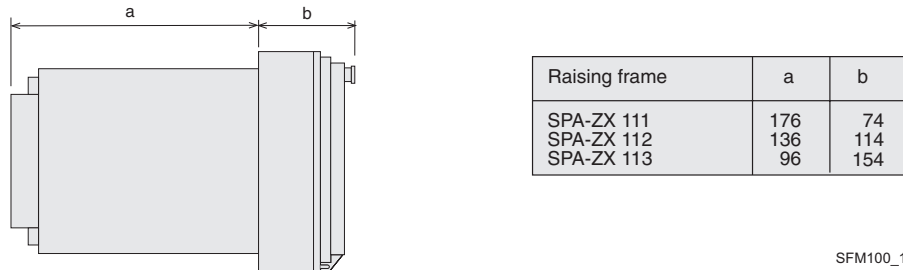

Fig. 3 Semi-flush mounting relay case (dimensions in mm)

Mounting in 19 inch cabinets and frames

An ancillary mounting plate, height 4U (~177 mm), is recommended to be used when the protection relays are to be mounted in 19 inch frames or cabinets. The ancillary mounting plate type SPA-ZX 104 accommodates three relays, type SPA-ZX 105 two relays and type SPA-ZX 106 one relay.

Projecting mounting

When projecting mounting is preferred, a relay case type SPA-ZX 110 is used. The relay case for projecting mounting is provided with front connectors.

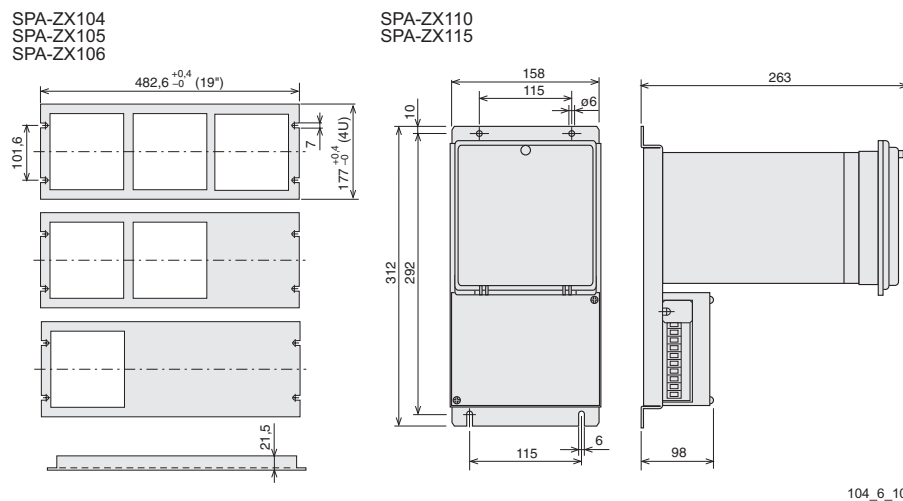

Fig. 4 Mounting cabinets and frames as well as projecting mounting (dimensions in mm)

**Ordering**

**When ordering, please specify:**

Ordering information	Ordering example
1. Type designation and quantity	SPAJ 141 C, 5 pieces
2. Order number	RS 611 007-AA
3. Rated values	$I_n=5\text{ A}$ , $f_n=50\text{ Hz}$
4. Auxiliary voltage	$U_{aux} = 110\text{ V dc}$
5. Accessories	-
6. Special requirements	-

**Order numbers**

Combined overcurrent and earth-fault relay SPAJ 141 C without test adapter	RS 611 007-AA, CA, DA, FA
Combined overcurrent and earth-fault relay SPAJ 141 C including test adapter RXP 18	RS 611 207-AA, CA, DA, FA
The last two letters of the order number indicate the rated frequency $f_n$ and the auxiliary voltage $U_{aux}$ of the relay as follows:	AA equals $f_n = 50\text{ Hz}$ and $U_{aux} = 80\dots265\text{ V ac/dc}$
	CA equals $f_n = 50\text{ Hz}$ and $U_{aux} = 18\dots80\text{ V dc}$
	DA equals $f_n = 60\text{ Hz}$ and $U_{aux} = 80\dots265\text{ V ac/dc}$
	FA equals $f_n = 60\text{ Hz}$ and $U_{aux} = 18\dots80\text{ V dc}$

**References**

**Additional information**

User's manual and technical description "Combined overcurrent and earth-fault relay SPAJ 141 C"	1MRS 750872-MUM EN
---	--------------------





**ABB Oy**  
Distribution Automation  
P.O. Box 699  
FI-65101 Vaasa, FINLAND  
Tel +358 10 22 11  
Fax +358 10 224 1094  
[www.abb.com/substationautomation](http://www.abb.com/substationautomation)