

Network analyzer

Monitoring power quality to ensure optimum operation

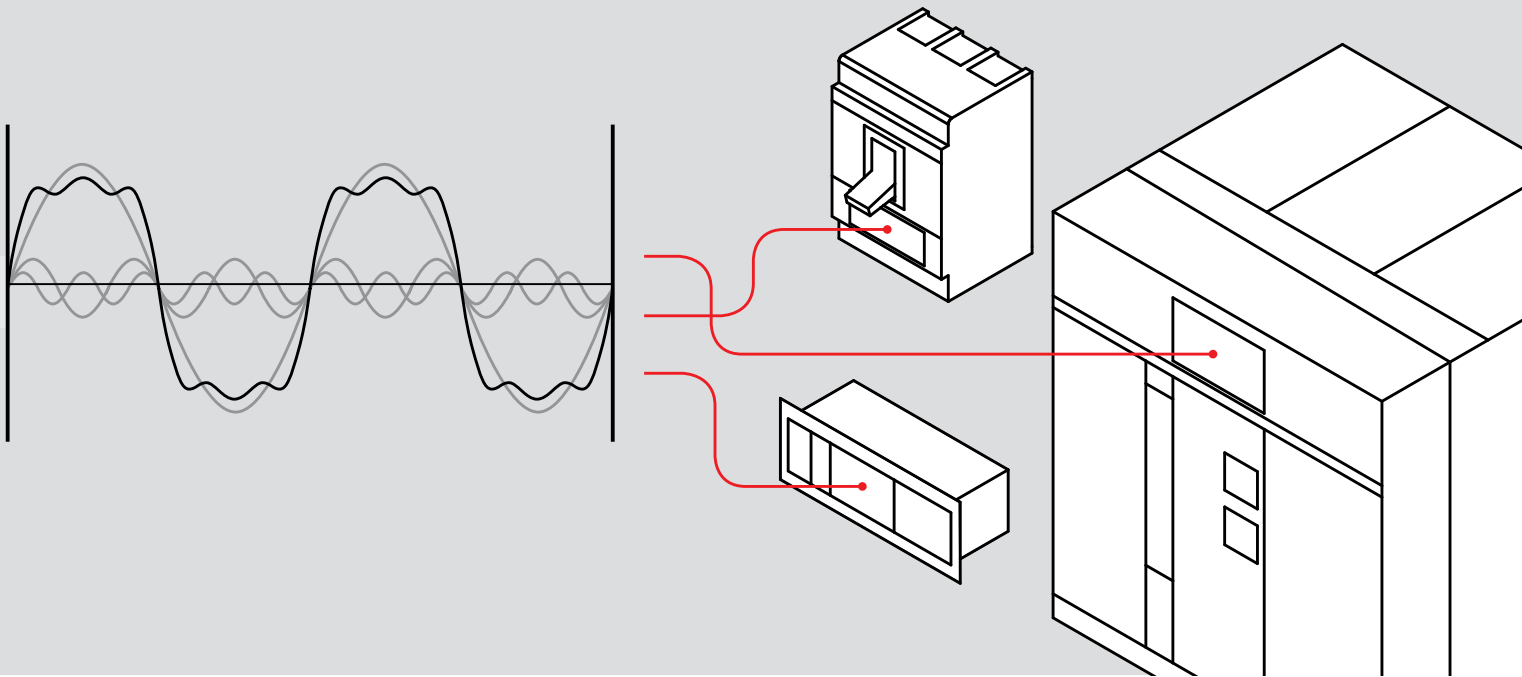

Power quality

Voltage is an input to every electrical system. When you travel from countries with 230V/50Hz to 120V/60Hz you will face this change in input.

Electrical equipment is designed for optimum operation under a smooth, constant voltage level as close as possible to the rated value. In addition, industrial equipment, working on three-phase supply, requires three phase voltage levels to be equal (balanced).

Power quality (PQ) is a description of how well a power system complies with the above ideal conditions.

Deviations, i.e. power quality issues, can have negative consequences on components and on energy efficiency of the network as a whole.

Thus, power quality monitoring becomes crucial with modern power systems, and will be a key part of the smart grid of the future.

In detail, power quality evaluation includes the following aspects:

- Deviations of voltage average value from its rated value
- Short interruptions and spikes of power supply
- Short decreases (sags) or increases (swells) of voltage value
- Voltage unbalance, i.e. difference in voltage values between different phases
- Presence of current and voltage harmonics.

Standards mandate specific PQ requirements.

Different Standards may be applicable to different kind of installation. For power distribution, the most widely used Standards are EN50160 in IEC world and IEEE 1250 in the UL world. A more specific example is the ITI (formerly known as 'CBEMA') curve, which summarizes voltage sags and swells that data processing equipment can tolerate.

1 Network Analyzer built-in inside ABB Ekip units is compliant to IEEE 1250-2011, Section 3 for the monitoring of voltage value, unbalance and harmonic content, which is the equivalent of IEC61000-4-30 Class S for voltage value and unbalance and Class B for harmonic content.

Application examples

Distortions of voltage value (sags, swells) and/or frequency can have fatal consequences, especially for process industries: production stopping with consequent expensive downtime, damages to motor drives and damages to PLCs are just some examples.

Examples of process industries that can be badly hit by voltage instabilities include food & beverage, plastics, pulp & paper, etc.

Voltage sag is defined when value of voltage is reduced below its rated value for a certain amount of time.

Single line-to-ground faults (lack of insulation or short-circuit between one phase and ground) on the utility system are a common cause of voltage sags. These kinds of faults are often caused by lightning, storms, wind gusts, falling tree branches and animals.

The voltage on the faulted phase goes to zero at the fault location and the voltage drop on loads in the area will depend on location of the fault. The voltage sag condition will last until fault is cleared by a protective device (fuse, breakers). Another common cause is the start-up of large loads, inside or outside of the installation.

Similarly, voltage swell is defined when voltage is increased above its rated value for a certain amount of time.

Thus, RMS value and frequency of voltage are two fundamental features of a voltage signal, but 'pureness' of voltage waveform is also an important point. An ideal voltage waveform should be a perfect sinusoid, but this usually does not occur in real world.

Frequencies other than the fundamental frequencies are always present. These are so called as harmonics: A harmonic signal is a frequency component of wave spectrum that is a multiple of the fundamental frequency.

Harmonic content is an issue that is becoming increasingly debated: technological developments in the industrial and household field have led to spread of electronic equipment which, due to their operating principle, absorb a non-sinusoidal current (non-linear load). Such current causes a voltage drop of non-sinusoidal type on the supply side of the network with the consequence that the linear loads are also supplied by a distorted voltage.

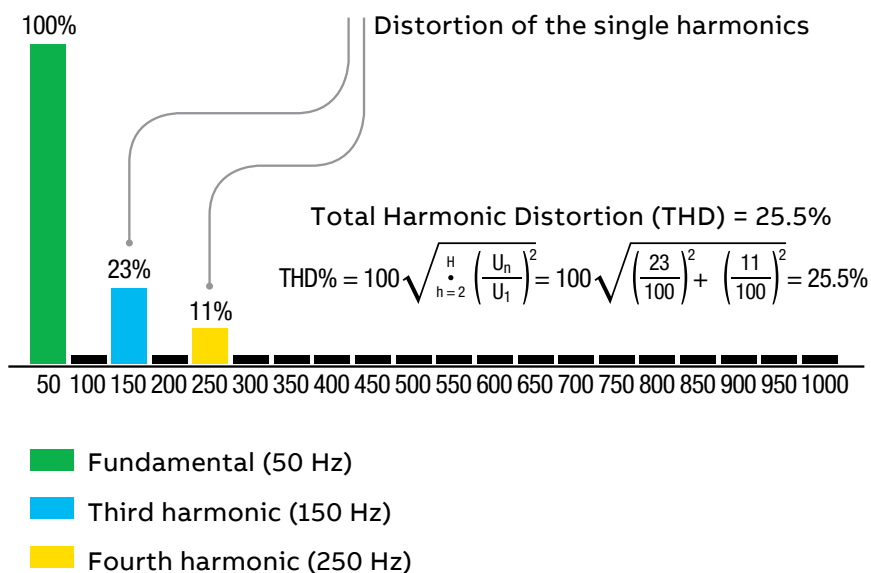

To get information about the harmonic content of voltage and current waveforms and to take measures if such values are high, a dedicated index has been defined.

The Total Harmonic Distortion (THD), of a signal is a measurement of harmonic distortion present and is defined as ratio of the sum of powers of all harmonic components to the power of that fundamental frequency.

The presence of harmonics in the electrical network may be the cause of equipment malfunctions, such as overloading of neutral conductor, an increase of losses in transformers, disturbances in motor torque etc. In particular, harmonics are the phenomenon that most heavily can affect power factor correction capacitors.

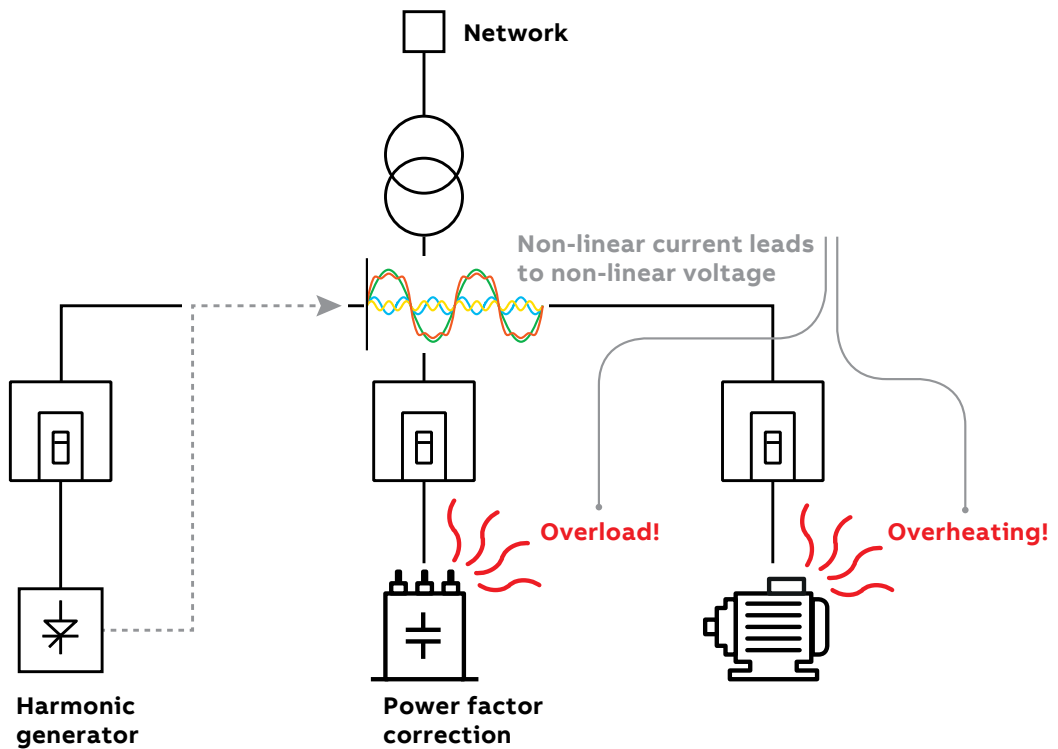

- 01 Tmax XT
- 03 Emax 2
- 04 Ekip UP



ABB Ekip electronics offers embedded Network Analyzer function to assist with determining power quality in low-voltage plants.

This innovative capability built-in inside Emax 2, Tmax XT circuit breaker and Ekip UP digital relay unit can manage electrical systems according to IEC 61000-4-30 and IEEE's 1250 Guide for Identifying and Improving Voltage Quality in Power Systems¹.

Benefits

Measurement of PQ is the first step for checking the status of the installation and starting the root cause analysis.

Using Ekip Hi-Touch trip units or all Ekip UP versions as a power quality monitor is a very interesting option, just considering:

- The ease of use as the power quality functions are already programmed inside the unit.
- The wide choice of communication protocols as information about power quality can be transmitted via several protocols, embedded in Ekip units.
- The cost-effectiveness as voltage sockets are already embedded inside these units and no more voltage transformers need to be purchased, reducing wiring requirements.

The Network Analyzer function also allows user to set controls on voltage in order to analyze system operation: At any time, when a control parameter exceeds the preset threshold, an alarm is generated. All following parameters are monitored continuously:

- Hourly average voltage value
- Short voltage interruption
- Short voltage spikes
- Slow voltage sags and swells
- Voltage unbalance
- Harmonic analysis

Referring to the voltage sag ambit, as an example, the Network Analyzer function can provide possibility of controlling three kind of sag classes, defined by the user.

Two different types of counters for each power quality monitoring function are available directly in trip unit touch screen: one is a cumulative counter, that stores all alarms (for example, all voltage sags) since the beginning, and another one is a 24h counter, that shows the alarms in the last 24 hours. With the optional communication module (Modbus, Profibus, Profinet, etc.) eight counters for each power quality monitoring function are available: one is the cumulative and the other seven are the daily counters of the last seven days of activity.

Parameter	Description
Sag Threshold (First Class)	Defines the first alarm threshold. It is expressed as % Un.
Sag Times (First Class)	In the event of dropping under the first alarm threshold, it defines the time beyond which the alarm counter is increased.
Sag Threshold (Second Class)	Defines the second alarm threshold. It is expressed as % Un.
Sag Times (Second Class)	In the event of dropping under the first alarm threshold, it defines the time beyond which the alarm counter is increased.
Sag Threshold (Third Class)	Defines the third alarm threshold. It is expressed as % Un.
Sag Times (Third Class)	In the event of dropping under the first alarm threshold, it defines the time beyond which the alarm counter is increased.