

Features and Benefits

- **Maximum Return on Investment:** New generations of software and system components provide increased operating efficiency, lower cost and extended system life. ABB offers low-risk evolution and upgrade strategies to assure maximum return on investment while enhancing equipment availability and performance.
- **Investment Protection Through Enhancement:** Reuse of existing controllers, I/O, and field wiring with newer operator interfaces and advanced applications, not only saves capital expenses but also provides the benefit of improved productivity.
- **Nonstop Production for Maximum Profit:** Symphony DCI provides the highest level of plant availability through redundancy at all levels.
- **Reducing Time to Decision and Action:** Conductor and 800xA Process Portal deliver intuitive software that allows the user to concentrate on the tasks at hand. Monitoring and maintenance management are performed quickly and efficiently.
- **Engineering for Maximum Performance:** The comprehensive, multi-user engineering tool provides functions for graphical engineering instead of programming. Efficient integration of Profibus field devices via GSD file import is also supported.

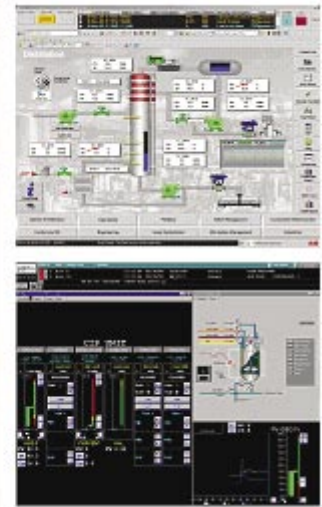

In today's business, there is a need for continuous productivity improvements to be competitive in the market. Traditional process control systems achieved high process availability, reliability, and process quality. But today, more is needed to be competitive. Industrial IT 800xA for DCI paves the way to reach this goal.

Symphony DCI is a proven process control system for demanding applications in various industries. The wide range of Symphony DCI references include pharmaceuticals, petrochemicals, sugar manufacturing, water and wastewater treatment, and many more. Symphony DCI's scalable redundancy enables maximum process availability.

Powerful controllers are networked via redundant EthernetTM. In addition, they constitute the links to I/O modules, field devices, operator stations, and engineering tools. However, Symphony DCI is not only a traditional control system. It continues to be improved and enhanced to remain a state-of-the-art system allowing customers to gain the competitive advantage. Today, Symphony DCI is enhanced with a number of 800xA applications, and this number is set to grow even further over time; thereby presenting the customer with a system that is well equipped to easily adapt to new opportunities and market requirements.

ABB has now combined the two worlds: Symphony DCI as best-in-class process control system with Industrial IT 800xA featuring best-in-class productivity enhancement software like 800xA Process Portal, Asset Optimization, and Information Management. With Industrial IT 800xA and Symphony DCI, plant operations are provided with the technology and solutions needed to achieve a sustainable competitive advantage by enabling the plant to perform with optimal productivity at substantial cost savings. In short, the integrated functions of 800xA can be added to Symphony DCI to extend the system capabilities.

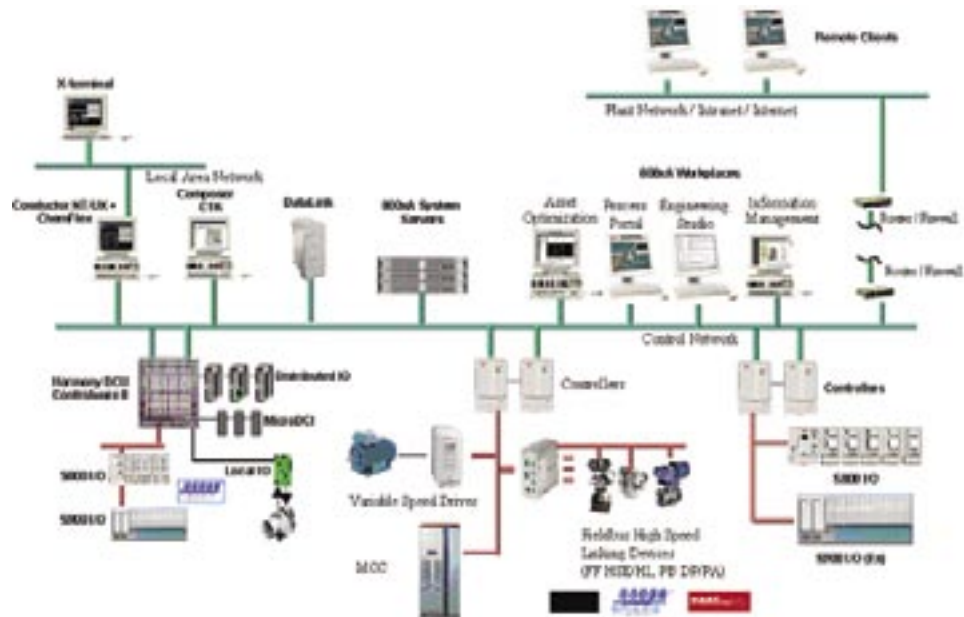

Figure 1. System architecture of Symphony DCI extended by 800xA

Symphony DCI Extended by Industrial IT 800xA Overview

Control & I/O

Customers have the freedom to choose the controller type that best fits the application. The customer can select a rack-based solution with the Harmony DCU controller. Additionally, the rail mounted Industrial IT AC 800M controller can be used for process automation or safety applications. It offers flexibility in field installations plus an integrated Foundation Fieldbus interface. Both controllers offer integrated redundancy for maximum availability. The powerful Harmony DCU controllers include a comprehensive scope of common and customized, industry-specific process functions, and redundant, integrated interfaces to Rack I/O, and redundant, integrated PROFIBUS DP interfaces to Fieldbus stations and devices.

The Profibus DP interface supports both Control IT™ S900 remote I/O for use in hazardous areas, or 800xA S800 I/O for non-hazardous areas. Both controller series, Harmony DCU and AC 800M, can be operated from the same operator interface.

An OPC-to-OPC mapping application called DataLink makes use of an OPC Server for DCI component to provide peer-to-peer communications between the AC 800M and Harmony DCU controllers. Use of DataLink enables information from the AC 800M, including Foundation Fieldbus systems, to participate within the Symphony DCI control strategies and configurations.



Figure 2. System architecture of Symphony DCI extended by 800xA

Refer to the following table for further details on related documentation:

Title	Document Number
Harmony DCU Overview	WBPEEUS230001C0
800xA Control & I/O Overview	3BSE034989
S900 I/O	50/17-03 EN

Engineering

Symphony DCI Composer™ CTK is a comprehensive, efficient multi-user engineering tool for planning, engineering, commissioning, diagnostics, and maintenance of one or more automation projects. Parallel engineering of planning and operating phases are supported. Composer CTK provides a function-block-oriented approach to design, with seamless integration of Profibus DP field device networking and configuration that is efficiently performed using embedded GSD files for S800 I/O and imported GSD files for other Profibus devices. For more details about Composer CTK, refer to the Composer CTK Overview, **WFPCEUS270010C0**.

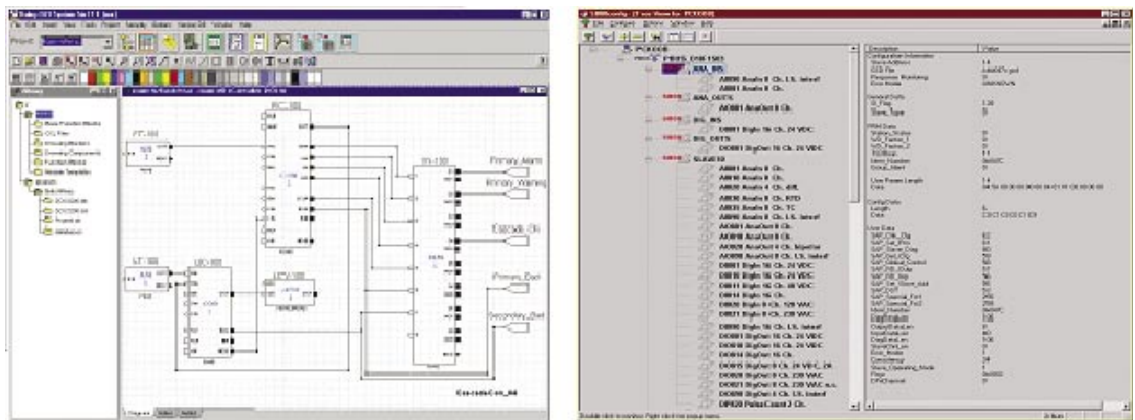

Figure 3. Composer CTK Function Block and Profibus network configuration

Batch

In order to automate batch-oriented production processes, a high degree of flexibility is required for the plant use and recipes so that the system can respond quickly to new demands. ChemFlex™ provides the integrated and automated batch management functionality needed to produce consistent high quality batches. A few examples of features from this widely used and tightly integrated application:

- Graphical recipe creation with parameter verification
- Consistent operation, from recipe to device
- Automatic recipe execution
- Recipe management
- Flexible equipment allocation
- Batch production with changing parameters
- Scheduling of batches and campaigns
- User-configurable redundancy
- Comprehensive documentation
- Integrated alarm and message management
- NAMUR/ISA® S88 standards applied

ChemFlex enables the system to respond quickly to market demands and ensure successful production.

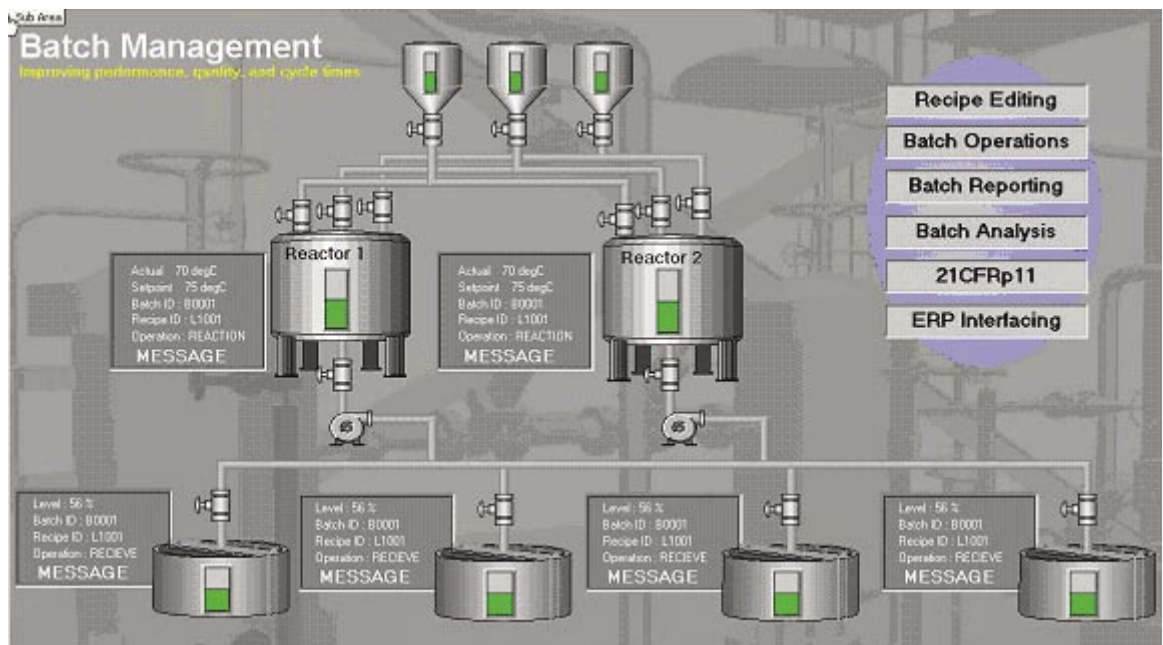

Figure 4. ChemFlex batch management is tightly integrated within the operator interface

Operations

As with the Control and I/O, customers have the freedom to choose the operator interface that best fits the application. The customer can select 800xA Process Portal or Conductor NT. Process Portal provides a tight integration with Symphony DCI by incorporating all the needed display and diagnostic tools for monitoring and controlling plant operations including faceplates and system status displays.

800xA Process Portal includes:

- Comprehensive operator functionality for handling normal and abnormal conditions including alarm and events, reporting functions, and remote mobile phone/pager/email messenger support.

- Personalized workplaces that are adjusted and optimized to users. Preferences and needs with individualized menus, tool bar contents and display locations.
- Intuitive and flexible navigation with quick information access via familiar web browser tools including favorite places, history lists, short cuts and hot buttons.
- Integrated data for informed decision-making providing rapid and consistent access to smart field devices, asset optimization tools, information management systems, safety systems, and MES applications.

For more details, refer to the 800xA Process Portal Overview, **3BSE034823**.

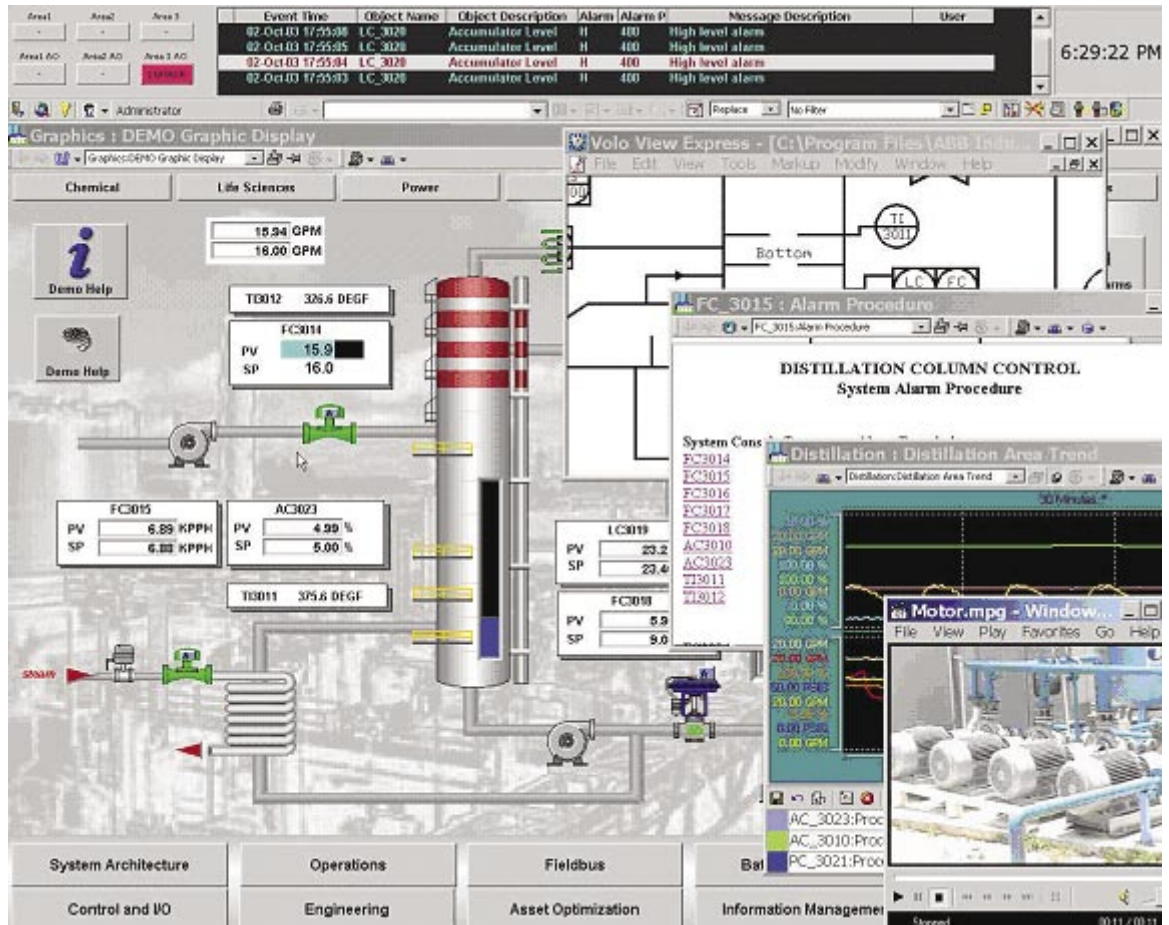

Figure 5. 800xA Process Portal with access to wide range of integrated information for improved decision making

Conductor NT is a reliable yet flexible operator interface that has a proven track record for providing secure and up-to-date information for plant operations. Meeting the traditional needs for plant automation control, Conductor hosts ChemFlex batch management and supports traditional operator displays and graphics as well as reporting and trending. 800xA Process Portal with tight integration to Symphony DCI, is the industry's most extensive operator interface providing consistent access and interaction with data from multiple control and I/O sources and plant and enterprise information.

Information Management

Powerful 800xA Information Management applications collect, store, retrieve and present historical, process and business data within an integrated 800xA workplace. Data from Symphony DCI is transferred into 800xA information via the 800xA for DCI OPC communications. Information Management enhances the usefulness of data from all operations within the enterprise to help identify bottlenecks and operating anomalies as well as the analysis of under-performing assets that adversely impact profits and productivity.

For more details, refer to the 800xA Information Manager Overview, **3BUS092079**.

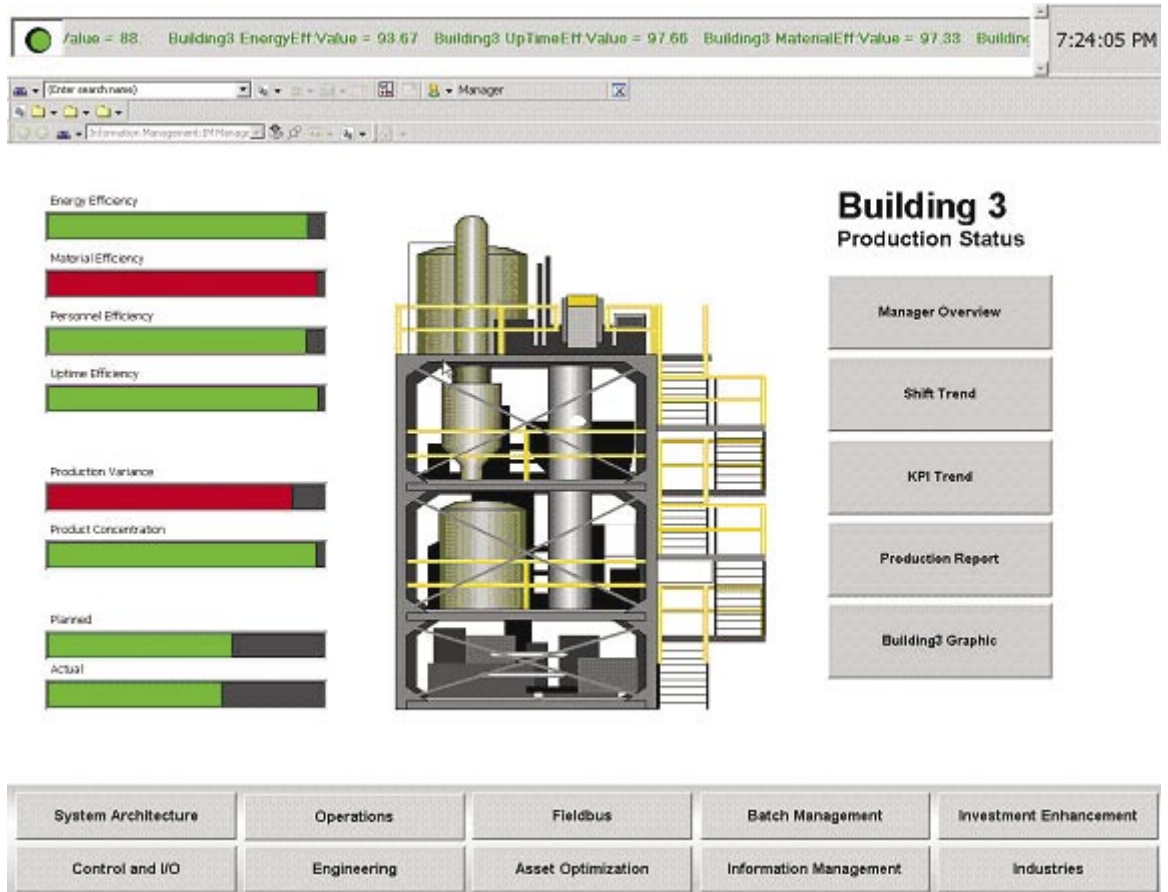

Figure 6. Information Management with key performance indicators ready @aGlance

Device Management

Fieldbus integration lowers lifecycle costs through significant cost savings in the design, implementation, and operation of field equipment. 800xA for DCI supports Foundation Fieldbus, Profibus DP and HART devices.

Foundation Fieldbus interfaces through the AC800M via the aforementioned DataLink peer-to-peer communications to participate within the Symphony DCI control strategies and configurations.

The Profibus DP network is interfaced through a direct connection with a PBUS I/O board mounted in the Harmony DCU frame. Tools for configuring the Profibus network and for integrating the Profibus devices within the Harmony DCU control strategies are supported by Composer CTK. The Profibus solution supports device definitions from GSD files that enable a common interface to configure, commission,

and maintain the Profibus devices intuitively and easily, aided by device-specific GSD files, which are supplied by the respective device manufacturers.

The harnessing of untapped potential from the substantial installed base of HART devices conforms with the ARC Advisory Group analysis that “Users can employ many of their HART field devices with new generation automation architectures, making the migration to a new Process Automation System more economical while increasing the availability of intelligent data that has long been underutilized.” Digital information from HART devices are accessed by the 800xA Fieldbus Management tools that physically connect to HART consolidation units. These consolidation units receive the HART device data by cable connections from multiple interface terminal boards (ITB's). These are the same ITB's that cable connect to the I/O boards in the Harmony DCU. The HART solution supports device parameterization and remote monitoring of signal statuses and PV's as well as diagnostic information through use of device-specific DTM's, which are supplied by the respective device manufacturers. In addition, the tight integration of the HART devices within the 800xA for DCI system enables improved device maintainability through asset monitoring and optimization.

For more details, refer to the 800xA Device Management Overview, **3BDD013081**.



Figure 7. 800xA Fieldbus Management Tool supporting HART device parameters and connection via HART OPC

Asset Optimization

800xA Asset Optimization software exploits the wealth of field resident information accessible through Fieldbus and higher-level systems to assess and document equipment conditions in real-time and enable personnel to schedule maintenance accordingly. Additionally, software seamlessly integrates plant's maintenance management and calibration management systems to greatly reduce costly corrective maintenance and time consuming preventive maintenance. Symphony DCI interfaces with 800xA Asset Optimization through 800xA for DCI OPC communications enabling full feature support including CMMS access.

For more details, refer to the 800xA Asset Optimization Overview, **3BUS092078**.

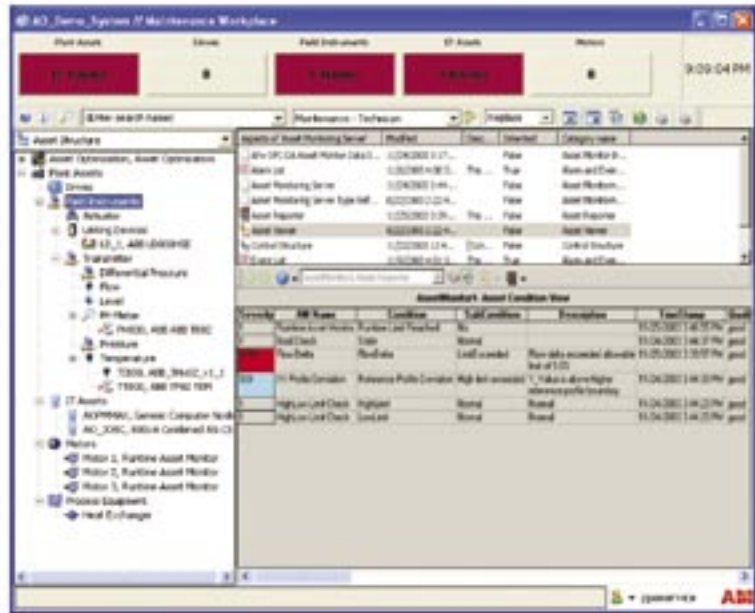

Figure 8. 800xA Asset Optimization supported through personalized workplace for Asset Health and Performance Monitoring

For the latest information on ABB visit us on the World Wide Web at <http://www.abb.com>



Automation Technologies
 Västerås, Sweden
 Phone: +46 (0)21 34 20 00
 Fax: +46 (0)21 13 78 45
www.abb.com/controlsystems
 e-mail: processautomation@se.abb.com

Automation Technologies
 Wickliffe, Ohio, USA
 Phone: +1 440 585 8500
 Fax: +1 440 585 8756
www.abb.com/controlsystems
 e-mail: industrialitsolutions@us.abb.com

Automation Technologies
 Mannheim, Germany
 Phone: +49 (0) 1805 26 67 76
 Fax: +49 (0) 1805 77 63 29
www.abb.de/controlsystems
 e-mail: marketing.control-products@de.abb.com

3BUS092083R0101

©Copyright 2005 ABB. All rights reserved. Specifications subject to change without notice. Pictures, schematics, and other graphics contained herein are published for illustration purposes only and do not represent product configurations or functionality. User documentation accompanying the product is the exclusive source for functionality descriptions.

The Industrial^{IT} wordmark, Aspect Objects, and all above-mentioned names in the form Operate^{IT} are registered or pending trademarks of ABB. All rights to other trademarks reside with their respective owners.