

## Bigger is better ABB drive systems designed to power mega mills in mining

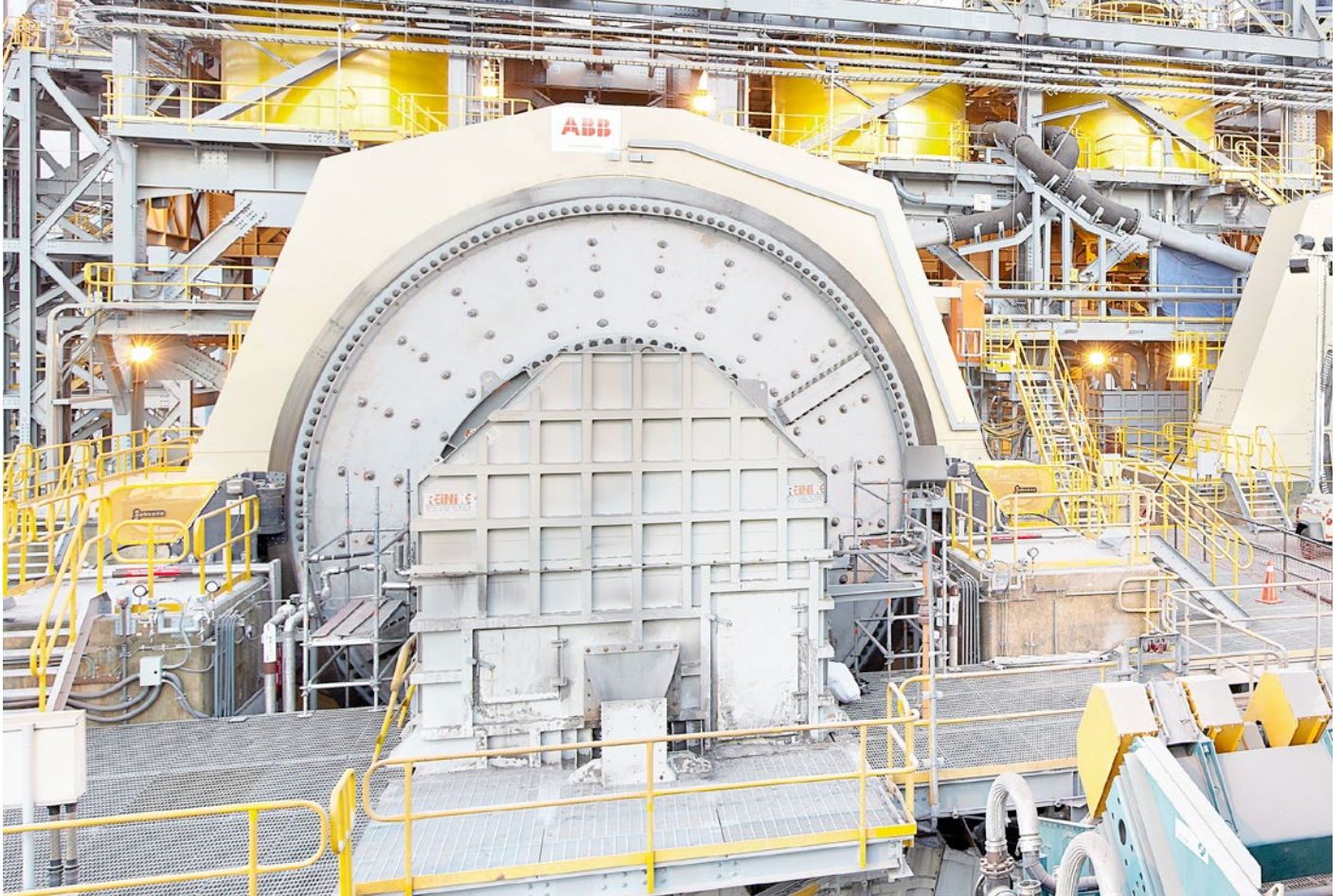

The challenge of decreasing ore grade quality around the world, makes higher productivity levels a must for mine operators. As a consequence, bigger mills with more powerful drive systems are becoming more popular every day. Designed to fit individual site requirements, ABB's drive systems are the ideal match for these mega mills.



# Bigger is better

ABB drive systems enable the mining industry to employ bigger mills

VENKAT NADIPURAM – One of the key challenges in the mining industry today is maintaining throughput in the face of ore grade quality that has declined by 40 percent in the last decade. Returns must be attractive even with energy costs and environmental regulations increasing. Industry analysts expect the mining industry to register modest growth in the coming decades, thereby making higher productivity essential. As an industry leader in mill drives, ABB combines its extensive industry knowledge with its application experience to provide a diverse portfolio of drive solutions for the mining industry.

---

#### **Title picture**

ABB drive solutions help operate the enormous mills being used in the mining industry today. This is the GMD at Esperanza Copper mine in Chile.

Throughout the comminution process, different mills are driven by different types of electrical drives.

### 1 Different processes used in comminution

Process	Size range (mm)
Explosion	∞ – 1000
Gyratory crusher	200 – 1000
Cone crusher	20 – 200
AG / SAG mill	2 – 200
Rod mill	5 – 20
Ball mill	0.2 – 5
HPGR	1 – 20
Stirred mills	0.001 – 0.2

<span style="display:inline-block; width:15px; height:10px; background-color:orange; border:1px solid black;"></span> Explosion	<span style="display:inline-block; width:15px; height:10px; background-color:yellow; border:1px solid black;"></span> Crushing
<span style="display:inline-block; width:15px; height:10px; background-color:lightgrey; border:1px solid black;"></span> Grinding	

### 2 Ball mill at Boliden Aitik copper mine



An example of an industry-standard comminution circuit providing high throughputs can be seen in → 3. This circuit, however, has a high specific energy consumption per ton of ore processed, driven primarily by the low efficiency of the ball mills and the need to use steel media for grinding.

**A**t the most basic level, mining is about freeing trapped valuable metal from its ore. However, there is nothing basic about the comminution of raw ore. Complex processes using a variety of different mills are carried out in order to reduce the size of the raw ore pieces to a more usable form → 1. Comminution circuits are typically connected by conveyor belts. Crushing and grinding are the two main and critical processes in a comminution setup, with each requiring reliable and energy-efficient equipment that also includes drive systems.

Comminution circuits are generally classified as either autogenous-ball milling-crushing (ABC) or semi-autogenous-ball milling-crushing (SABC) circuits. An ABC circuit consists of an autogenous grinding (AG) mill, ball mill and crusher. An SABC circuit consists of a semi-autogenous grinding (SAG) mill, ball mill, and crusher. A ball mill is a slightly inclined, horizontal rotating cylinder, partially filled with ceramic balls, flint pebbles or stainless steel balls, that grinds material to the necessary fineness by friction and impact with tumbling balls → 2.

#### Ring-gear mill drive

Throughout the comminution process, different mills are driven by different types of electrical drives. ABB provides a variety of different types of drive solutions for the mining industry.

For example, ring-gear mill drive (RMD) systems are good solutions when the power required to drive the mill is under 18 MW, ie, a maximum of 9 MW per pinion → 4. Yet as tube mills grow in size in order to meet the demand for larger throughputs, the power required to drive them increases. Although ABB can manufacture drive systems for very large power ratings, the physical limitation of a mechanical gear limits its application for driving tube mills where the power required is over 18 MW.

#### Gearless mill drive

The limitation of an RMD system was overcome by ABB when it introduced the first gearless mill drive (GMD) in 1969 for the cement industry. ABB introduced the first GMD into the minerals industry in 1985 and since then it has become the de facto standard equipment for mines with larger throughput requirements. ABB has sold and installed over 120 GMD units worldwide.

### 3 SABC flow sheet

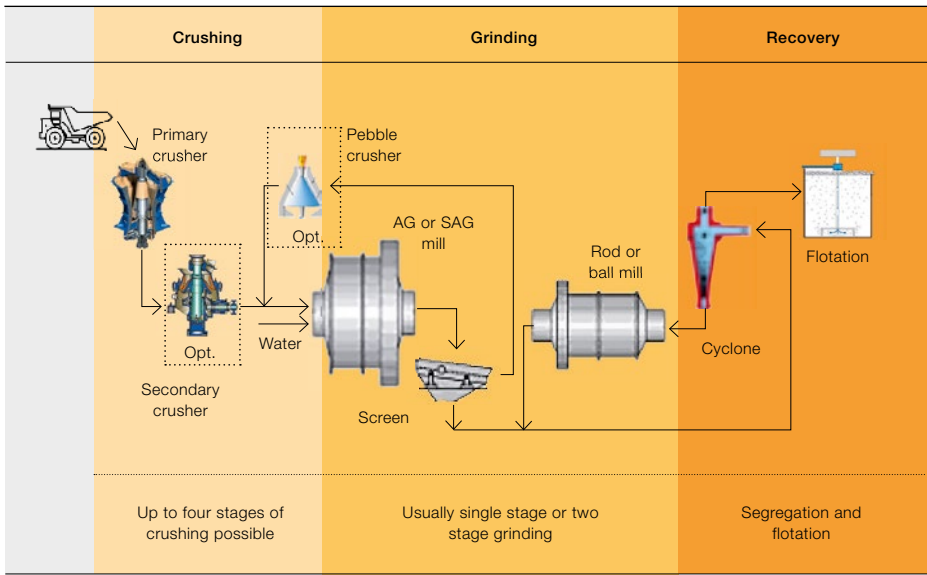

### 4 Ring-gear mill drive solutions

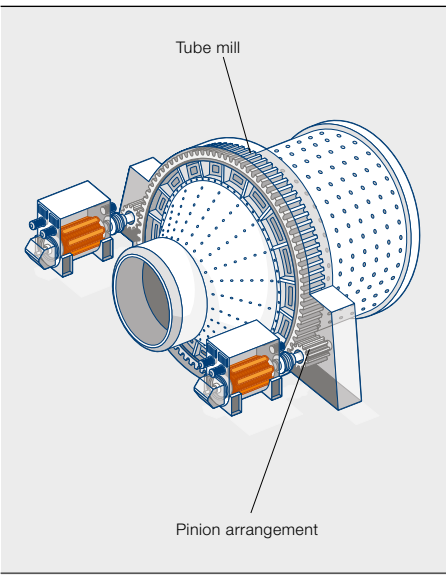

### 5 Gearless mill drive solution

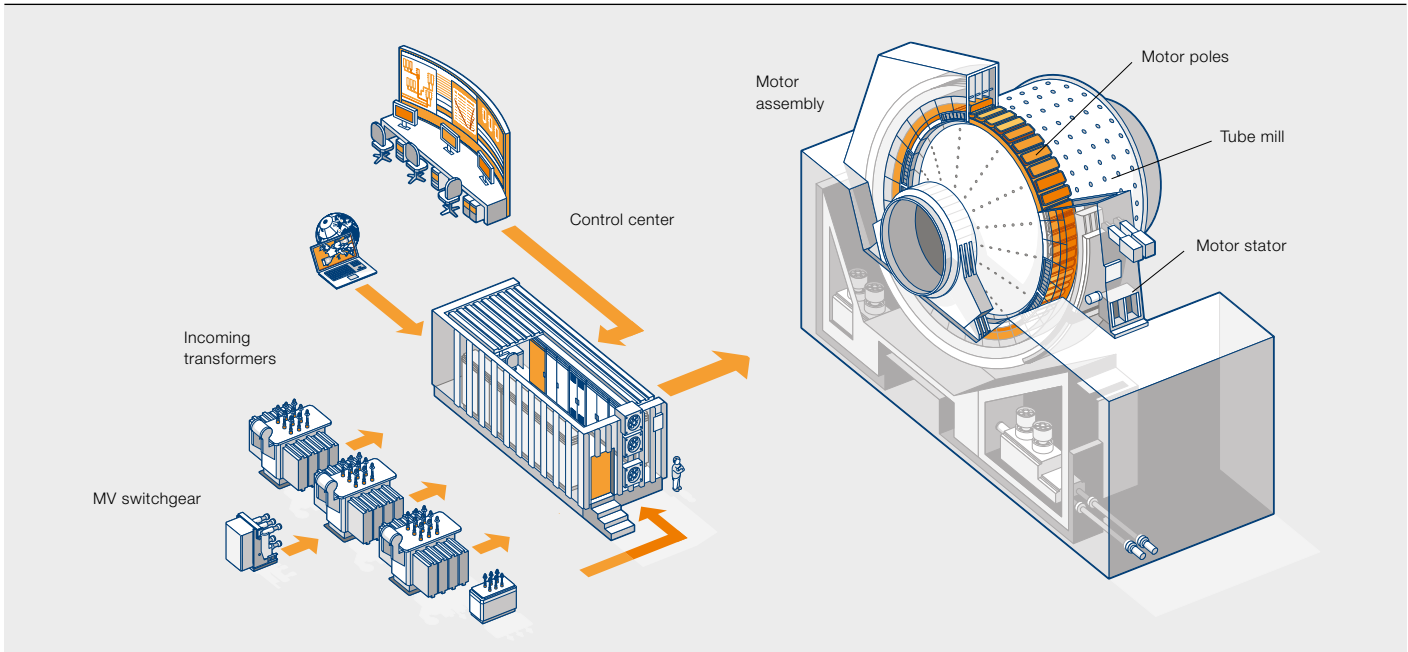

The advantages of a GMD application in the minerals grinding process have been well established over the past 40 years, with the benefits increasing exponentially as the mills get bigger.

In the GMD solution the drum of the mill forms the rotor of the motor, with the motor poles mounted along the external circumference of the drum → 5. The stator is mounted around the pole assembly. The operation is carried out with high precision so that the final gap between the poles and the stator is no more than 14–16 mm, depending on the mill size.

By not having a gearbox (gear and pinion), the mechanical limitation associated with gears is eliminated. This allows mill diameters to increase as required. The world's largest GMD, with a diameter of 12.8 meters, will be delivered by ABB to the Conga mine in Peru.

Eliminating gears improves the efficiency and availability of the mills and reduces maintenance work. The intrinsic ability of GMDs to provide variable speed improves the overall efficiency of the grinding process in terms of energy used and grinding result. Variable speed also reduces network sags during mill startup and allows features like frozen

Eliminating gears improves the efficiency and availability of the mills and less maintenance work is needed.

ABB provides optimized, state-of-the-art drive solutions for HPGR mills and currently has the largest installed base for the over 2 MW power range.

#### 6 Full vacuum pressure impregnation for windings



charge protection, controlled roll back and positioning for mill maintenance needs.

#### Design improvements

Since the introduction of GMDs, ABB has delivered customized solutions for every individual mine and process requirement, from power ratings and size to site altitude. ABB's most recent achievement in this area was commissioning a 28 MW system at 4,600 m above sea level.

ABB continues to develop new features and designs to guarantee higher availability and reduced maintenance, partic-

including the slot section and the winding overhang area, which is important for high-altitude applications. The stator core sheets are pressed together to increase the overall stiffness, which minimizes the retightening work required during the ring-motor lifetime.

#### GMD condition monitoring

ABB has developed advanced remote diagnostic tools for troubleshooting as well as predictive maintenance. For example, with up-to-date operation information from the system, operators are notified of any potential problem long before an automatic alarm or trip is activated. Notifications are sent by e-mail or text messages to the mine operators as well as ABB remote diagnostic engineers → 7.

The diagnostic tools monitor a wide range of signals from all the key components

of the GMD system including transformers, cycloconverters and the ring motor. This allows for continuous analysis of the system status and the ability to inform the customer in a reliable and timely manner of any potential problems that may arise during operation.

#### A maturing grinding technology

Today's mining industry is increasingly facing a new challenge: how to develop bigger grinding machines to sustain

## The grinding process with HPGRs is a dry process, thus saving water, which is a scarce resource in many mining sites.

ularly for high-altitude and remotely located mines.

For example, particular attention has been given to the stator winding insulation. The stator winding consists of a bar winding with individually insulated strands that are intertwined to use the entire copper cross section almost evenly while reducing losses and lowering eddy currents → 6. These strands are packed in a Mica-based VPI insulation. The whole stator bar is "VPIed,"

## 7 Screen shot of an ABB remote GMD condition monitoring console

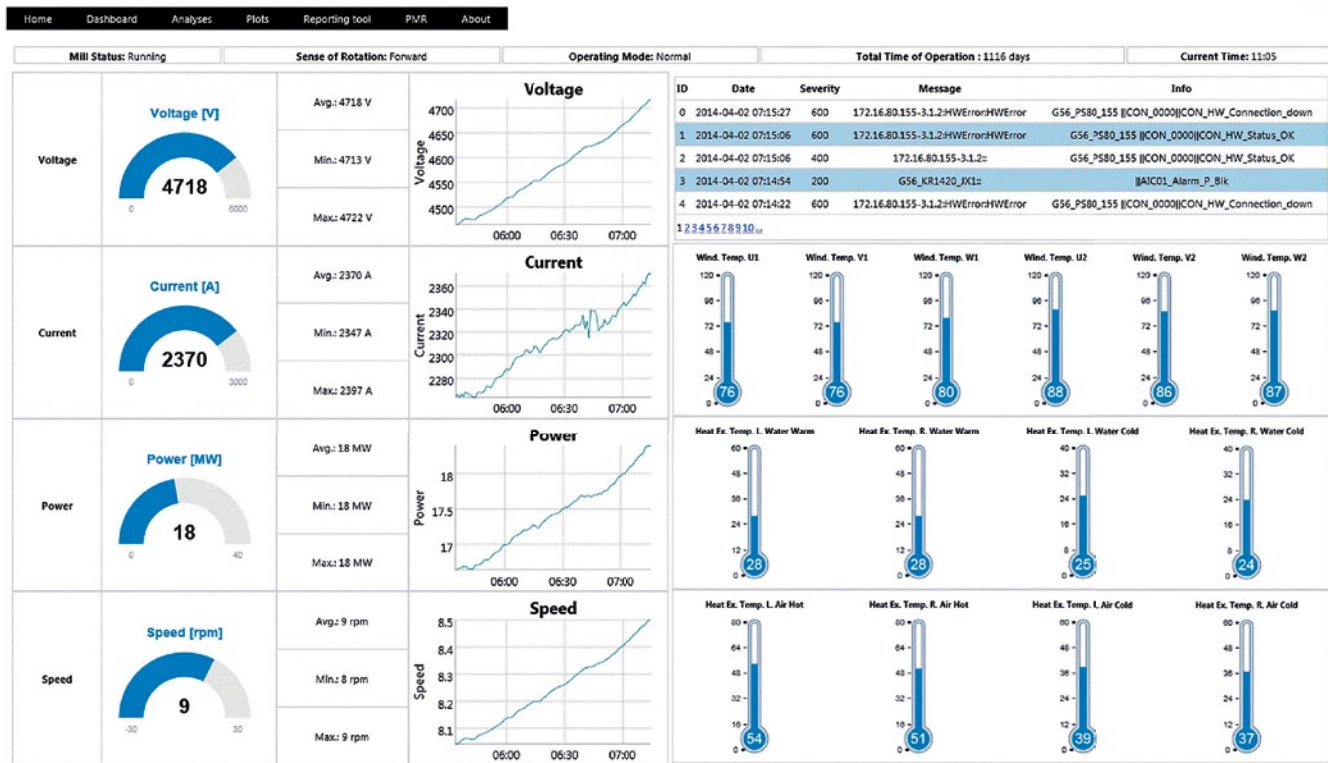

## 8 Operating principle for a HPGR

High-pressure grinding is achieved by using an advanced type of grinding roll. The machine consists of two counter-rotating rolls. One of the rollers is fixed and the other is movable in a horizontal direction. A constant pressure is applied to the moving roller via hydraulic cylinders to impart pressure to the material.

Contrary to conventional crushing rolls, the particles are broken by compression in a packed particle bed, and not by direct nipping of the particles between the two rolls. This particle bed is created between two choke-fed, counter-rotating rolls. Between these rolls, a particle bed is pressed to a density of up to roughly 85 percent of the actual material density.

This compression is achieved by using high pressure of up to nearly 300 Mpa, exceeding the compression strength of the feed ore. During this compacting process the material is ground to a wide particle size distribution with a large proportion of fines, compacted into flakes.

The figure shown here indicates the flow of the material between the two rollers. The figure also depicts different zones, namely the "A zone" in which the material is pushed or accelerated toward the compaction zone; the "C zone," where the material is pressed; and then discharged into the "E zone."

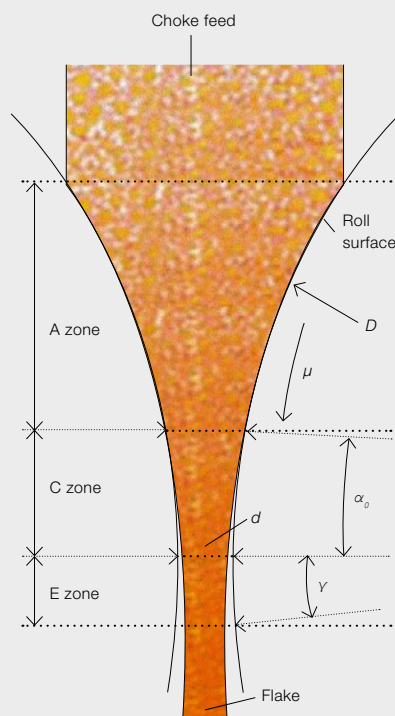

- A zone = Acceleration zone
- C zone = Compaction zone
- E zone = Expansion zone
- $D$  = Diameter of rolls
- $d$  = Flake thickness
- $\alpha_c$  = Angle of compaction zone
- $\gamma$  = Angle of expansion zone
- $\mu$  = Circumferential speed

throughput with steadily declining grades, while at the same time minimizing energy consumption.

One way of meeting the challenge is to use high-pressure grinding rolls (HPGRs). HPGRs have proven to be extremely effective for grinding mineral raw materials, especially since manufacturers have developed roll-wear protection systems to better deal with hard and abrasive ores → 8.

Additionally, the grinding process with HPGRs is a dry process, thus saving water, which is a scarce resource in many mining sites, eg, Chile.

### Comminution circuits with HPGRs

The multiple benefits of including an HPGR mill in comminution circuits has operators looking to combine them with other types of mills in order to optimize the total specific energy consumption of a comminution setup.

There are numerous benefits of using HPGRs in comminution circuits in comparison with conventional grinding processes using SAG mills. The most significant benefit is an up to 20 percent increase in energy savings. Also, metal liberation is improved, a reduced grind-

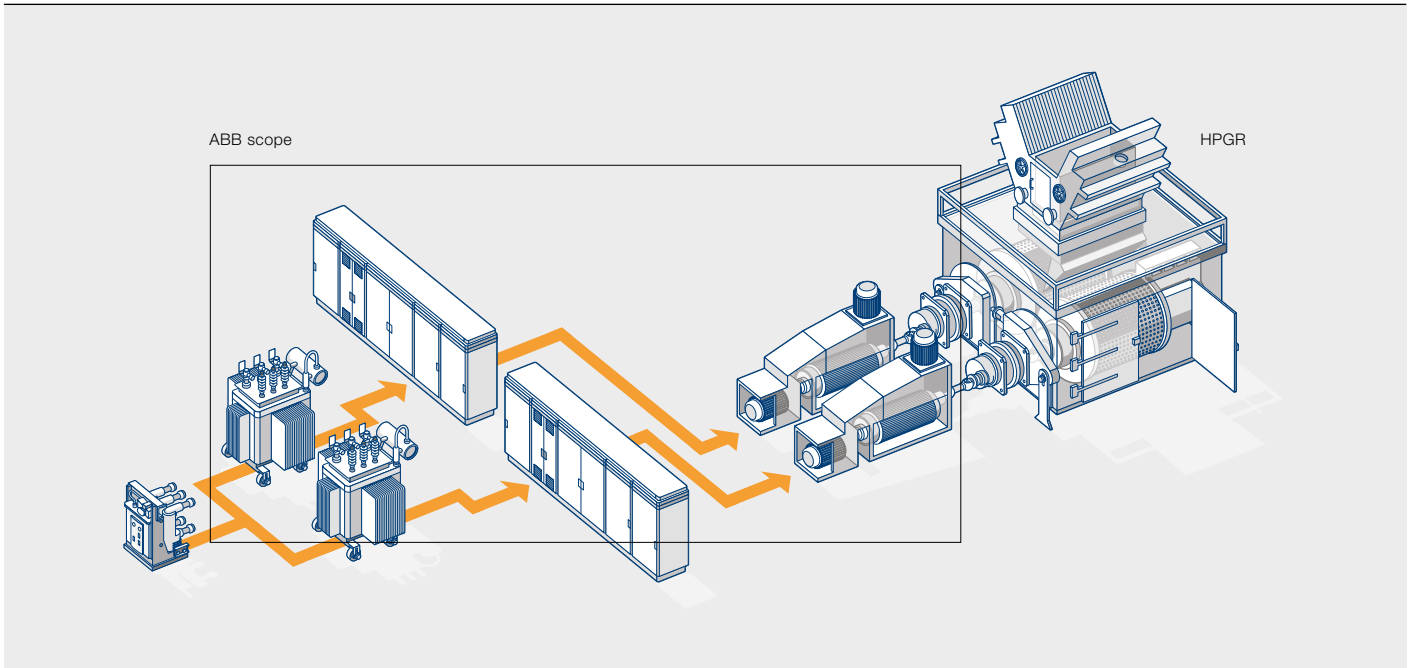

ability index is reached, commissioning times are shortened and designs are more compact.

HPGRs have been used successfully in mining operations over the years, indicating an increasing maturity of the product. As units become larger with higher throughput and deliver better reduction ratios than tertiary crushers, the combining of secondary crushers with HPGRs to replace SAG mills is occurring more often → 10.

**ABB offerings**

ABB provides optimized, state-of-the-art drive solutions for HPGR mills and currently has the largest installed base for the over 2MW power range → 9. The ABB HPGR drive solution provides identical load sharing between both rolls at the desired speed. Being able to adjust the speed to fit actual ore properties decreases mechanical stress on the grinding application. The drive system is capable of compensating the reduction of circumferential speed caused through roll wear by increasing the motor speed (rpm). In this manner, the throughput can be maintained at optimized values over the rolls' lifetime. The direct torque control (DTC) feature provides the fastest torque/speed response on the market, enabling quick and accurate adjustment to the frequent load transients typical in HPGR applications as different sizes of material enter.

**10 A comminution setup using HPGRs replacing SAG in primary grinding process.**

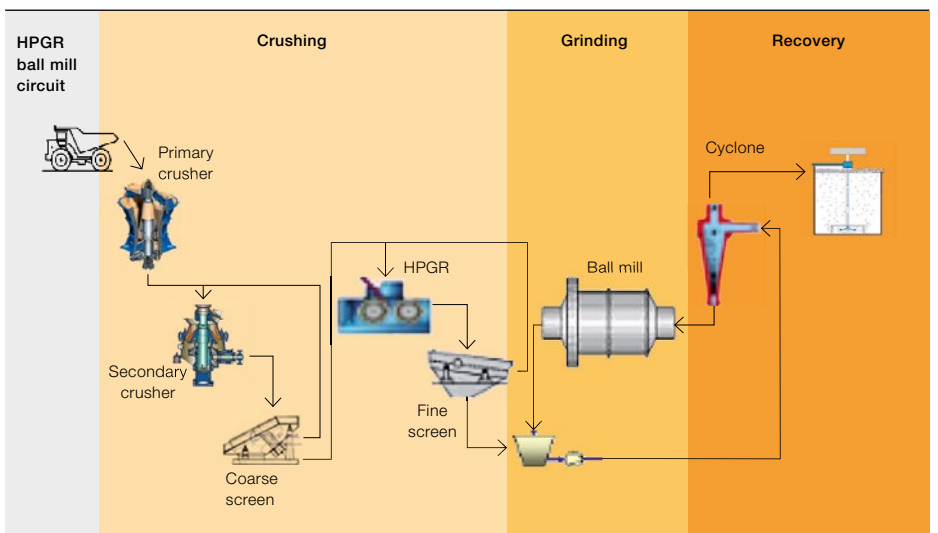

HPGRs are poised to play an important role in the comminution circuits to help reduce energy costs, water requirements and footprint compared with the traditional SABC circuits. While being a standard solution in mineral processing, HPGR technology continues to undergo constant development. ABB is at the forefront of this development with many new features being added to further optimize drive system performance.

**Venkat Nadipuram**

ABB Process Automation, Industry Solutions  
Baden-Dättwil, Switzerland  
venkat.nadipuram@ch.abb.com

# Contact us

## Global Competence and Execution Center for grinding solutions

### ABB Switzerland Ltd.

Segelhofstrasse 9P  
5405 Baden 5 Dättwil  
Switzerland  
Phone: +41 58 586 84 44  
E-mail: [minerals@ch.abb.com](mailto:minerals@ch.abb.com)

ABB's Mining business is represented in the following countries:

Australia, Brazil, Canada, Chile, China, Germany, Peru, South Africa, Sweden and Switzerland.

For contact details, please visit our website:

[www.abb.com/mining](http://www.abb.com/mining)