

# ***INSTRUCTION MANUAL***

***MAGNETIC FLOWMETERS  
50SD1000 Design Level D***

## ***UNIVERSAL CONVERTER/DRIVER***



**PN24695A**

The following is a registered trademark of ABB Inc.:

MAG-X®

The following is a registered trademark of the HART Communications Foundation:

HART®

**WARNING** notices as used in this manual apply to hazards or unsafe practices which could result in personal injury or death.

**CAUTION** notices apply to hazards or unsafe practices which could result in property damage.

**NOTES** highlight procedures and contain information which assist the operator in understanding the information contained in this manual.

All software, including design, appearance, algorithms and source codes, is copyrighted and owned by ABB Inc. or its suppliers.

**WARNING**

**POSSIBLE PROCESS UPSETS**

Maintenance must be performed only by qualified personnel and only after securing equipment controlled by this product. Adjusting or removing this product while it is in the system may upset the process being controlled. Some process upsets may cause injury or damage.

**NOTICE**

The information contained in this document is subject to change without notice.

ABB Inc., its affiliates, employees, and agents, and the authors of and contributors to this publication specifically disclaim all liabilities and warranties, express and implied (including warranties of merchantability and fitness for a particular purpose), for the accuracy, currency, completeness, and/or reliability of the information contained herein and/or for the fitness for any particular use and/or for the performance of any material and/or equipment selected in whole or part with the user of/or in reliance upon information contained herein. Selection of materials and/or equipment is at the sole risk of the user of this publication.

This document contains proprietary information of ABB Inc., and is issued in strict confidence. Its use, or reproduction for use, for the reverse engineering, development or manufacture of hardware or software described herein is prohibited. No part of this document may be photocopied or reproduced without the prior written consent of ABB Inc.

## Table of Contents

<b>SAFETY SUMMARY</b> .....	<b>I</b>
<b>READ FIRST</b> .....	<b>III</b>
<b>1.0 INTRODUCTION</b> .....	<b>1-1</b>
1.1 Description .....	1-1
1.2 Model Number Breakdown .....	1-3
1.3 Specifications .....	1-6
<b>2.0 INSTALLATION</b> .....	<b>2-1</b>
2.1 Inspection .....	2-1
2.2 Location and Mounting .....	2-1
2.2 Electrical Interconnections .....	2-2
<b>3.0 START-UP AND OPERATION</b> .....	<b>3-1</b>
3.1 New System Installations for Converter/Driver with Flowmeter .....	3-1
3.2 Continuous Submergence or Accidental Submergence Applications .....	3-1
3.3 Retrofitting the Converter/Driver in an Existing Installation .....	3-2
3.3.1 Check Output Current .....	3-3
3.3.2 Check Reference Voltage .....	3-3
3.3.2.1 Selection of Proper Value of R56 .....	3-3
3.3.2.2 Adjustment of R54 .....	3-4
3.3.3 Start-Up .....	3-5
3.3.4 Set the required drive frequency on 50XM Converters .....	3-5
3.3.5 Determine the meter calibration factor (cal-factor) .....	3-5
3.3.6 Set span .....	3-6
3.3.7 Setting System Zero .....	3-6
3.3.8 Proceed with flow measurement .....	3-6
3.3.9 If the meter is not operating .....	3-7
3.3.10 Special applications information .....	3-7
<b>4.0 FUNCTIONAL DESCRIPTION OF DRIVER MODULE</b> .....	<b>4-1</b>
4.1 Description .....	4-1
<b>5.0 CALIBRATION</b> .....	<b>5-1</b>
5.1 General .....	5-1
<b>6.0 MAINTENANCE</b> .....	<b>6-1</b>
6.1 General .....	6-1
6.2 System Troubleshooting of the Universal Converter/Driver .....	6-1
6.2.1 Troubleshooting the System .....	6-2
6.2.2 Troubleshooting Within the Electronics Enclosure .....	6-3

<b>7.0 CONVERSION OF MAGNETIC FLOWMETERS.....</b>	<b>7-1</b>
7.1 Conversion of Models 10D1418 and 10D1430.....	7-1
7.2 Conversion of Model 10D1419.....	7-1
7.3 Conversion of Model 10D1435.....	7-1
7.4 Conversion of Models 10D1465, 10D1475, and 10D1476.....	7-2
7.5 Coil Current Settings for Models 10D1418 and 10D1419.....	7-3
7.6 Coil Current Settings for Models 10D1430, 10D1435 and 10DX3111.....	7-3
7.7 Coil Current Settings for Models 10D1465, 10D1475, and 10D1476.....	7-4
 <b>8.0 PARTS LIST.....</b>	 <b>8-1</b>

---

### Figure List

---

FIGURE 1-1. DRIVER MODULE WITH 50XM CONVERTER.....	1-9
FIGURE 1-2. DRIVER MODULE WITH CD1 CONVERTER.....	1-10
FIGURE 1-3. DRIVER MODULE WITHOUT CONVERTER.....	1-11
FIGURE 2-1. OUTLINE DIMENSIONS AND MOUNTING ARRANGEMENT.....	2-3
FIGURE 2-2. INTERCONNECTION DIAGRAM FOR UNIVERSAL CONVERTER/DRIVER WITH 50XM CONVERTER.....	2-4
FIGURE 2-3. INTERCONNECTION DIAGRAM FOR UNIVERSAL CONVERTER/DRIVER WITH CD1 CONVERTER.....	2-5
FIGURE 2-4. INTERCONNECTION DIAGRAM FOR UNIVERSAL CONVERTER/DRIVER WITH REMOTE CONVERTER.....	2-6
FIGURE 2-5. INTERCONNECTION DIAGRAM FOR UNIVERSAL CONVERTER/DRIVER WITH CONTINUOUS SUBMERGENCE FLOWMETER.....	2-7
FIGURE 2-6. INTERCONNECTION DIAGRAM FOR UNIVERSAL CONVERTER/DRIVER WITH ACCIDENTAL SUBMERGENCE FLOWMETER.....	2-8
FIGURE 2-7. CABLE SIZING REQUIREMENTS.....	2-9
FIGURE 3-1. DRIVER FEEDBACK JUMPER ON 50XM1000N CONVERTER.....	3-8
FIGURE 4-1. DRIVER MODULE BLOCK DIAGRAM.....	4-3
FIGURE 4-2. DRIVER MODULE WAVEFORM DIAGRAM.....	4-3
FIGURE 5-1. CALIBRATION DIAGRAM FOR 50XM CONVERTERS.....	5-2
FIGURE 5-2. CALIBRATION DIAGRAM FOR CD1 CONVERTERS.....	5-3
FIGURE 7-1. WIRING MODIFICATION FOR MODEL 10D1419.....	7-6
FIGURE 7-2. WIRING MODIFICATION FOR MODEL 10D1435.....	7-7

---

### Table List

---

TABLE 3-1. SELECTION OF R56 VALUE.....	3-3
TABLE 7-1. MODELS 10D1418 AND 10D1419.....	7-3
TABLE 7-2. MODELS 10D1430 AND 10D1435.....	7-3
TABLE 7-3. MODEL 10D1465.....	7-4
TABLE 7-4. MODEL 10D1475.....	7-5
TABLE 7-5. MODEL 10D1476.....	7-5
TABLE 8-1. DRIVER MODULE.....	8-1
TABLE 8-2. SIGNAL CABLE.....	8-1
TABLE 8-3. COIL CABLE.....	8-1

## SAFETY SUMMARY

---

### GENERAL WARNINGS

**POSSIBLE PROCESS UPSETS.** Maintenance must be performed only by qualified personnel and only after securing equipment controlled by this product. Adjusting or removing this product while it is in the system may upset the process being controlled. Some process upsets may cause injury or damage.

**RETURN OF EQUIPMENT.** All equipment being returned to the factory for repair must be free of any hazardous materials (acids, alkalis, solvents, etc.). A Material Safety Data Sheet (MSDS) for all process liquids must accompany returned equipment. Contact the factory for authorization prior to returning equipment.

**INSTRUCTION MANUALS.** Do not install, maintain or operate this equipment without reading, understanding and following the proper instructions and manuals, otherwise injury or damage may result.

**ELECTRICAL SHOCK HAZARD.** Equipment powered by AC line voltage presents a potential electric shock hazard to the user. Make certain that the system power is disconnected from the operating branch circuit before attempting electrical interconnections or service.

### SPECIFIC WARNINGS

Equipment powered by ac line voltage constitutes a potentially lethal electric shock hazard. Installation and servicing of the Universal Converter/Driver and/or the signal converter should only be attempted by a qualified technician. Make certain that the power input leads are disconnected from the operating branch circuit before attempting electrical connections. (pg. 2-2)

**SPECIFIC  
CAUTIONS**

It is the responsibility of the user to provide a water tight conduit system. The warranty is voided if condensation is permitted to enter the flowmeter and/or the signal converter housings. (pg. 2-1)

Since the Driver Module's output is a floating bridge, under no circumstances should the Driver Module be used with a grounded oscilloscope or DVM. Permanent damage to the Driver module may result if this precaution is not taken. (pg. 3-2, 3-5)

Since the universal converter/driver's output is a floating bridge, under no circumstances should troubleshooting of the Universal Converter/Driver be attempted using a grounded oscilloscope or DVM. Permanent damage to the Universal Converter/Driver may result if this precaution is not taken. (pg. 6-1)

In order to use the Universal Converter/Driver with any of the following flowmeters, the magnet coil wires "MR" coming from inside the flowmeter and "M2" from the standard converter must be removed from their respective terminals on the flowmeter printed circuit board and connected together with an insulated splice or wire nut. (pg. 7-4)

## **READ FIRST**

---

### **WARNING**

#### **INSTRUCTION MANUALS**

Do not install, maintain, or operate this equipment without reading, understanding and following the proper factory-supplied instructions and manuals, otherwise injury or damage may result.

#### **RETURN OF EQUIPMENT**

All Flowmeters and/or Signal Converters being returned to the factory for repair must be free of any hazardous materials (acids, alkalis, solvents, etc). A Material Safety Data Sheet (MSDS) for all process liquids must accompany returned equipment. Contact the factory for authorization prior to returning equipment.

Read these instructions before starting installation;  
save these instructions for future reference.

### **Contacting the Factory . . .**

Should assistance be required with any of the company's products, contact the following:

**Telephone:**

**24-Hour Call Center  
1-800-HELP-365**

**E-Mail:**

**[ins.techsupport@us.abb.com](mailto:ins.techsupport@us.abb.com)**

The NEMA 4X rating applies to the meter body and electronics enclosure only. The following accessories (if supplied) may not meet NEMA 4X unless specifically ordered as NEMA 4X:

- meter flanges
- meter installation hardware: studs, nuts, bolts
- enclosure mounting hardware for pipe or wall mounting
- conduit hardware

This product is painted with a high performance epoxy paint. The corrosion protection provided by this finish is only effective if the finish is unbroken. It is the users' responsibility to "touch-up" any damage that has occurred to the finish during shipping or installation of the product. Special attention must be given to: meter flange bolting, pipe mounting of electronics, conduit entries and covers that are removed to facilitate installation or repair. For continued corrosion protection throughout the product life, it is the users' responsibility to maintain the product finish. Incidental scratches and other finish damage must be repaired and promptly re-painted with approved touch-up paint. Provide the model number and size of your product to the nearest factory representative to obtain the correct touch-up paint.



## 1.0 INTRODUCTION

---

### 1.1 Description

The 50SD1000 Universal Converter/Driver is designed to operate the coils of most flowmeters and process the resultant signal. It consists of a high power constant current magnet driver and one of two available signal converters packaged in a common NEMA 4X enclosure. The driver module is primarily designed to permit use of the 50XM1000 and CD1 signal converters with flowmeters whose magnet coils require more power than these Converters can provide.

All sizes of U.S. manufactured flowmeters from 1/25 to 78 inches (1 to 1950 mm) can be supplied for **new installations** with the Universal Converter/Driver. All sizes of U.S. manufactured flowmeters from 1/25 to 54 inches (1 to 1300 mm) can be **retrofitted** with the Universal Converter/Driver. For retrofit of other sizes consult the factory.

The driver module is an assembly consisting of two printed circuit boards and is designed to provide a stable bipolar current to an inductive load, in particular the field coils of a flowmeter. The direction of this current is controlled from an isolated logic input, typically provided by a signal converter such as the 50XM1000 or the CD1. The steady state output current of the driver module is adjusted by means of a two decade digital switch, and can be in the range of .05 to 1.5 amperes at up to 15 volt-amperes or 30 volts. With these characteristics, the driver module will provide magnet coil excitation for the majority of flowmeters.

In addition, the driver module may be adapted to flowmeters of other manufacturers if their coil parameters are applicable. For these applications consult the factory.

In addition to the above features, the driver module provides circuitry for the following:

- generation of a reference signal (magnet coil current) for use with the companion signal converter
- a self test circuit to aid in set-up and troubleshooting
- Light-emitting Diode (LED) monitor for indicating normal operation.

The 50XM1000 signal converter is a micro-processor controlled pulsed DC signal converter of modular design using state-of-the-art surface mounted technology. Refer to the 50XM1000 Instruction Bulletin for additional information.

The CD1 signal converter is a analog DC pulsed converter. The CD1 signal converter consists of the converter and output printed circuit boards which are assembled to provide a compact modular electronics package. Refer to the CD1 instruction bulletin for additional information.

The data in this instruction bulletin supersedes similar information in the flowmeter and signal converter instruction bulletins. All other information in the flowmeter and signal converter instruction bulletins remains valid.

Refer to the applicable illustration:

FIGURE 1-1. DRIVER MODULE WITH 50XM CONVERTER

FIGURE 1-2. DRIVER MODULE WITH CD1 CONVERTER

FIGURE 1-3. DRIVER MODULE WITHOUT CONVERTER

The Universal Converter/ Driver (1% of rate) can be used with any flowmeter of the same size and model (e.g., a Universal Converter/Driver calibrated for a 2 inch (50 mm) 10D1475 flowmeter can be used with any meter of that size and model).

A Universal Converter/Driver that requires 1/2% of rate accuracy must be installed as a system with the flowmeter with which it was calibrated. To retrofit a 1/2% of rate Universal Converter/Driver in the field requires that the mating flowmeter be returned to the factory.

## **1.2 Model Number Breakdown**

Refer to the instrument data sheet or the data tag on the equipment for the model number of the instrument furnished. The details of a specific number are as follows:

1.2 Model Number Breakdown (continued)

	<b>50SD1</b>	-	-	-	<b>D</b>	-	-	-	-	-	-	-	-	-	-	-	-
<b>Engineering Reference</b>																	
<b>Converter Type</b>																	
No Converter		0															
2nd Generation 50XM1000 Converter		1															
CD-1 Converter		2															
Converter Remote From Driver Enclosure		3															
<b>Power</b>																	
110/115/120 VAC, 50/60 Hz			1														
220/230/240 VAC, 50/60 Hz			2														
<b>Enclosure</b>																	
Field Mount NEMA-4X with Window				0													
Field Mount NEMA-4X with Window used with Continuous or Accidental Submergence Primary				1													
<b>Design Level</b>					<b>D</b>												
<b>Coil Excitation Frequency</b>																	
7.5/6.25 Hz						1											
15/12.5 Hz						2											
3.75/3.125 Hz						3											
<b>Converter Software</b>																	
Current Version							1										
Not Applicable							X										
<b>Display</b>																	
Rate Display (unlighted)								1									
3-Button Keypad w/Lighted Display								3									
None								4									
<b>Accessories</b>																	
None																	AA
Empty Pipe Detector																	AB
External Totalizer Reset																	AC
Empty Pipe Detector & Ext. Totalizer Reset																	AD
HART® Protocol																	AE
HART® Protocol & Empty Pipe Detector																	AF
HART® Protocol & Ext. Totalizer Reset																	AG
HART® Protocol, Ext. Totalizer Reset & Empty Pipe Detector																	AH

1.2 Model Number Breakdown (continued)

<b>50SD1</b>	_	_	_	<b>D</b>	_	_	_	_	_	_	_	_
<b>Output Options</b>												
None												1
Pulse Output, Active FWD/REV												2
RS485 Port (N/A w/ HART <sup>®</sup> Protocol)												5
RS232C Port (N/A w/ HART <sup>®</sup> Protocol)												6
RS485 Port & Opto Pulse Output FWD (N/A w/ HART <sup>®</sup> Protocol)												7
RS232C Port & Opto Pulse Output FWD (N/A w/ HART <sup>®</sup> Protocol)												8
Hardware Scaler with Binary Div.												9
<b>Certification</b>												
None												A
FM Approved as Non-Incendive CLI, Div 2, Groups ABCD												K
Non-Incendive Field Wiring CLI, Div 2, Groups ABCD, NEMA 4X												
<b>Driver Output Current to Coils</b>												
Unknown												0
0.05 - 0.19 Amps												1
0.20 - 0.69 Amps												2
0.70 - 1.50 Amps												3
<b>Output Signal</b>												
4 to 20 mA												2
0 to 20 mA												3
0 to 1000 Hz												7
<b>Output Pulse Width</b>												
No Pulse Output												1
Configurable from 0.032 to 2000 mS												5
50 μS, 5 - 24 VDC												7
50 mS, 5 - 120 VAC/VDC												8

### 1.3 Specifications (Driver Module Only)

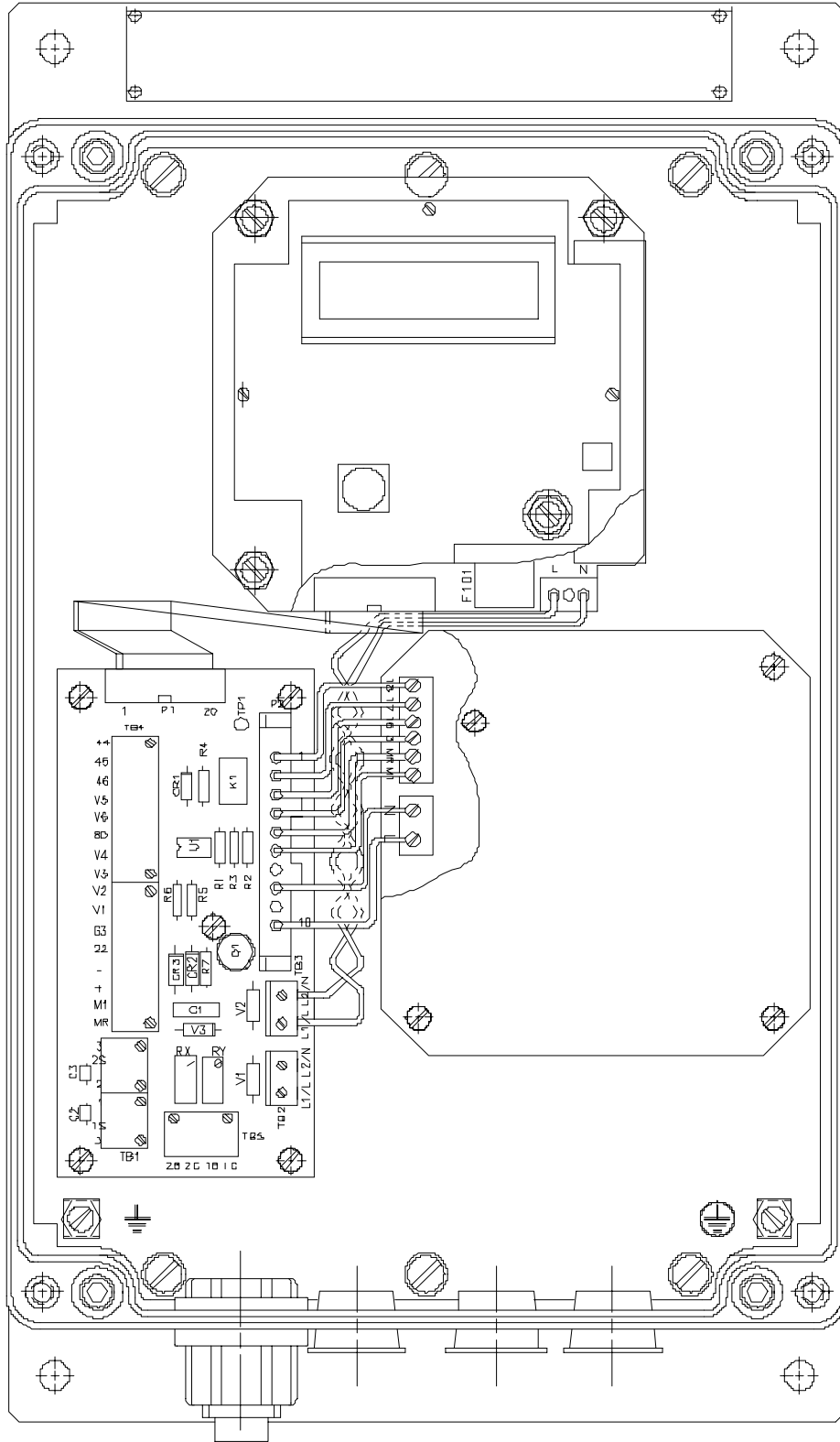
**NOTE**  
For signal converter specifications refer to the applicable Instruction Bulletin.

<b>Driver Coil Current</b>	$\pm 0.05$ to $\pm 1.5$ amperes constant current (isolated). Setting accomplished by switches SW1 and SW2 (see Figures 1-1, 1-2, and 1-3).
<b>Voltage Output</b>	$\pm 2$ to $\pm 30$ volts, depending on current and load requirements.
<b>Output Power</b>	Up to 15 VA at driver output terminals (includes wiring loss).
<b>Input Power:</b>	
<b>Normal Condition</b>	120 or 240 Volts ac $\pm 10\%$ @ 50/60 Hz $\pm 1$ Hz and consuming less than 25 watts.
<b>Operative Limits</b>	99-132 or 198-264 volts @ 47 to 63 Hz
<b>Load Impedance</b>	Magnet load must measure between 2 and 100 ohms and must have an L/R time constant between 1 and 50 milliseconds. Module requires setting of switch SW3 to stabilize various loading situations.
<b>Accuracy of Coil Current</b>	$\pm 2\%$ of switches SW1 and SW2 setting plus an additional $\pm 0.002$ ampere.
<b>Output Ripple and Noise</b>	Not to exceed 2% of $I_{out}$ or 1 milliampere at frequencies less than 10 kHz.
<b>Initial Voltage Applied to Load</b>	Jumper W2 selectable to 40 or 20 volts, as required by output load.
<b>Output Response Time</b>	Current through magnet coils with time constants less than 10 milliseconds will settle within 1% of final value in under 10 milliseconds.
<b>Synchronizing Signal</b>	The external synchronizing device must provide a square wave whose amplitude is at least 0 to -6 volts into a 1500 ohm load but whose amplitude shall not exceed $\pm 40$ volts. The driver isolates this signal from the remainder of the circuitry.

<b>Reference Voltage Output</b>	A current sensing resistor and accompanying adjustable voltage divider network are provided so that a $\pm 70$ millivolt reference voltage representing coil current may be derived for the associated signal converter.
<b>Ambient Temperature Limits</b>	Normal operation from $-13$ to $131^{\circ}$ F ( $-25$ to $55^{\circ}$ C) at up to 10 VA output; temperature limited to $122^{\circ}$ F ( $50^{\circ}$ C) above 10 VA output.
<b>Driver Operating Limits</b>	$-13$ to $149^{\circ}$ F ( $-25$ to $65^{\circ}$ C)
<b>Storage and Transportation</b>	$-40$ to $185^{\circ}$ F ( $-40$ to $85^{\circ}$ C)
<b>Output Change Versus Temperature</b>	Additional inaccuracy not to exceed 3% of setting plus an additional 5 milliamperes when operated over normal temperature limits $-13$ to $131^{\circ}$ F ( $-25$ to $55^{\circ}$ C).
<b>Output Stability Versus Line Voltage</b>	A 10% change in line voltage will result in less than .65% change in driver output current.
<b>Output Stability Versus Load Resistance</b>	A 10% change in load resistance will result in less than .35% change in driver output current.
<b>Circuit Efficiency</b>	Output VA at the M1-MR terminals will typically be 63% of the wattage measured on the ac power line.
<b>Output Stability Under the Influence of RFI</b>	The reference voltage output at terminals 16 and 3 will shift less than 1% when subjected to an external field of 30 volts/meter from 20 to 1000 MHz (equivalent to SAMA Class 3 A, B and C).
<b>Relative Humidity</b>	No change of output will be observed when the device is subjected to relative humidity ranging from 10 to 90% (noncondensing).
<b>Vibration</b>	Driver will operate normally when subjected to 1 G from 5 to 200 Hz (amplitude not to exceed 0.1"). The driver will survive intermittent exposure to 2 G under the above conditions.
<b>Shock</b>	Driver will not be affected by a 5 G 1/2 sine wave shock persisting for 11 milliseconds.
<b>Thermal Shock</b>	Driver will not be affected by a thermal shock of $2^{\circ}$ F ( $1.1^{\circ}$ C) per minute.

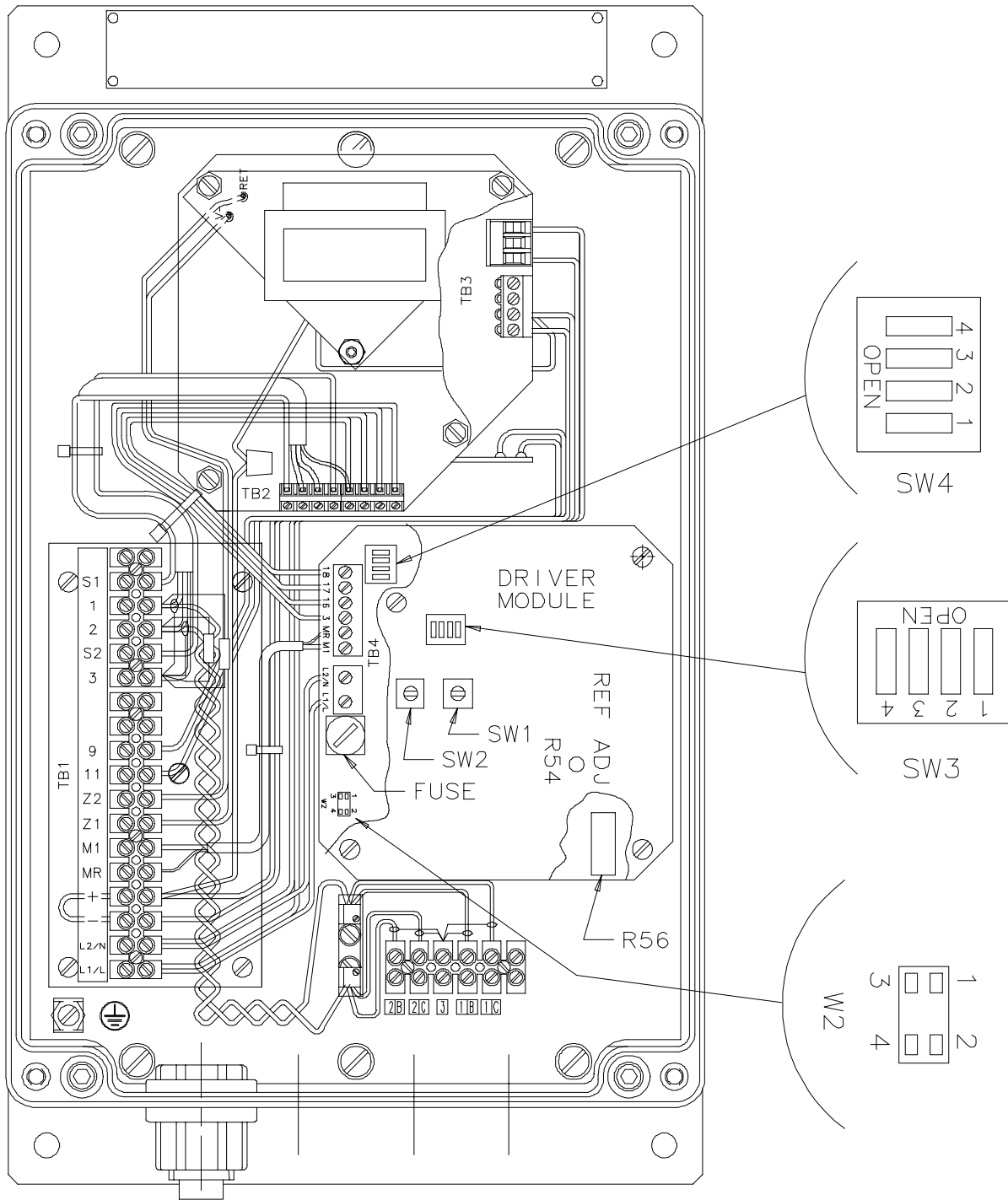
<b>External Magnetic Field</b>	Application of an external magnetic field of 0.5 Gauss will not result in a change of the device output.
<b>Surge Withstanding Capability</b>	Driver will not be affected when the ac power line terminals are subjected to 3000 volt impulses impressed through a 150 ohm driving impedance (IEEE 472 Spec).
<b>Monitor Circuitry</b>	Normal operation is indicated by a flashing LED lamp.
<b>Self Test Circuitry</b>	Provision has been made to operate all circuitry within the driver module in the absence of any external signals.





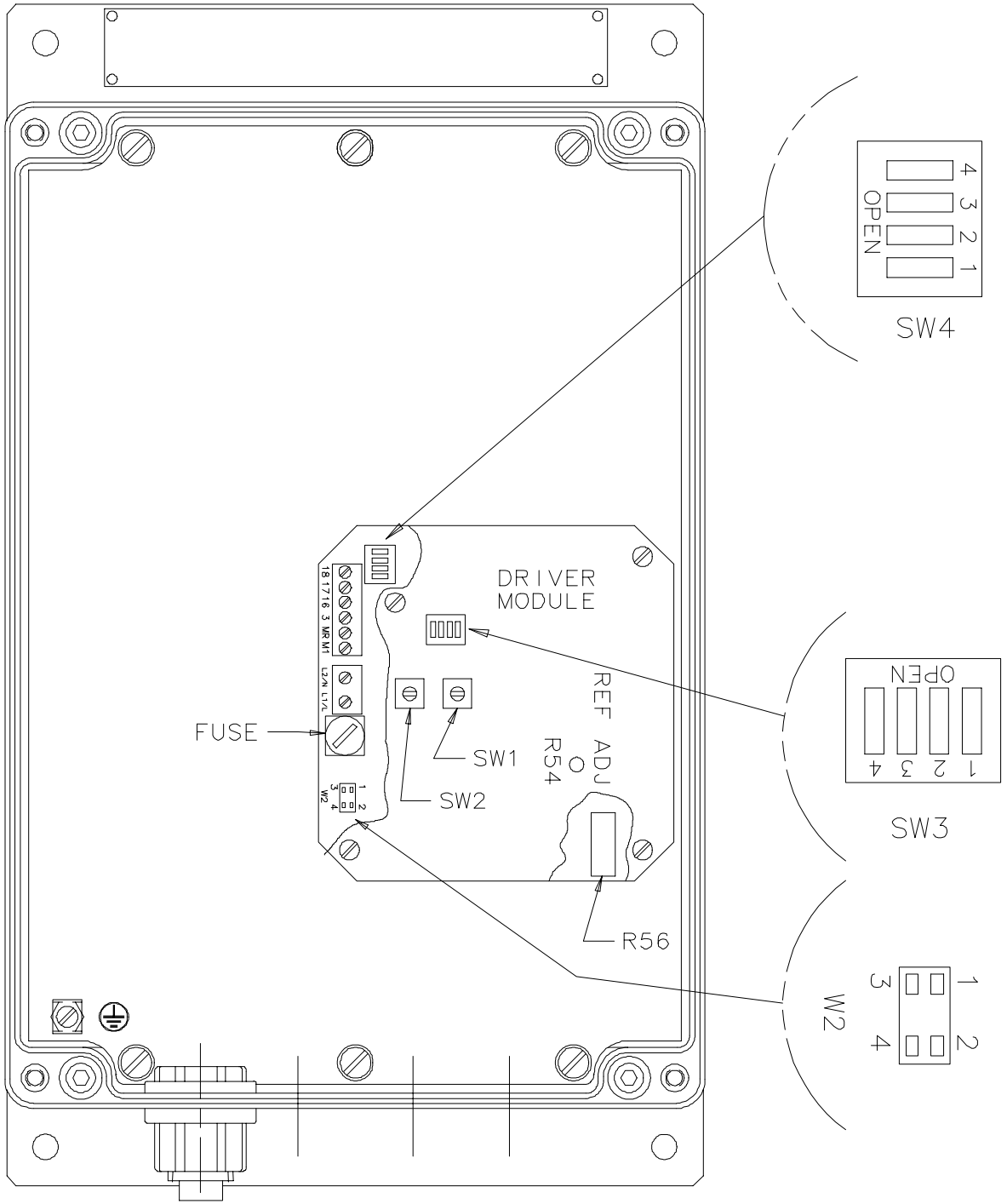
(REF SD-50-2453)

**FIGURE 1-1. DRIVER MODULE WITH 50XM CONVERTER**



CSI-7416-1

FIGURE 1-2. DRIVER MODULE WITH CD1 CONVERTER



CSI-7415-1

FIGURE 1-3. DRIVER MODULE WITHOUT CONVERTER

## 2.0 INSTALLATION

---

### 2.1 Inspection

The equipment should be inspected immediately upon arrival for indications of damage that may have occurred during shipment. In the event damage is such that faulty operation is likely to result, this damage should be brought to the attention of the factory Service Department before installation is attempted. Always reference the complete instrument serial number and model number in all correspondence concerning the equipment supplied.

Following inspection of the shipment contents, it is recommended that all items be replaced in the shipping container for storage and/or transit to the installation site.

### 2.2 Location and Mounting

**CAUTION**

It is the responsibility of the user to provide a water tight conduit system. The warranty is voided if condensation is permitted to enter the flowmeter and/or the signal converter housings.

The installation site for the Universal Converter/Driver should be clean, well lighted and adequately ventilated. Also, consideration should be given to access requirements for repair and maintenance of the equipment. The enclosure is designed to meet NEMA 4X standards, and is suitable for indoor and outdoor installation in an environment that is within the temperature, humidity and vibration limits given in Sub-Section 1.3.

Mounting dimensions for the enclosure are provided in Figure 2-1. The housing should be mounted in a vertical position with the conduit openings on the bottom. **All conduit/cable entries must be equipped with conduit entry seals and unused entrances must have pipe plugs installed.** This is required to maintain the NEMA 4X rating. Mounting hardware for wall mounting is supplied by the user.

An alternative mounting option permits the 50SD1000 housing to be mounted to a 2 inch horizontal or vertical pipe. The pipe clamping brackets and mounting hardware are supplied by the factory. Insert the two 5/16-18 x 3-3/4 inch long bolts into the holes provided in the pipe mounting bracket. Orient the bracket as required for vertical or horizontal pipe. As shown in Figure 2-1, this pipe mounting bracket must be attached to the rear of the enclosure. Four 1/4-20 x 1/2 inch long self-tapping screws are supplied with the pipe mounting kit for attaching the bracket. To mount the 50SD1000, place the housing with the attached bracket against the mounting pipe with the pipe between the two 3-3/4 inch long bolts. While supporting the housing, install the pipe clamping bracket, flat washers and hex nuts. Tighten the nuts alternately to maintain even pressure distribution across the clamping bracket. Check that the housing is plumb before securing.

The housing cover is removable to facilitate access for installation and maintenance. For installation remove the covers from the housings by loosening the screws on the cover. **Replace the cover when the installation has been completed.**

**WARNING**

Equipment powered by ac line voltage constitutes a potentially lethal electric shock hazard. Installation and servicing of the Universal Converter/Driver and/or the signal converter should only be attempted by a qualified technician. Make certain that the power input leads are disconnected from the operating branch circuit before attempting electrical connections.

## 2.2 Electrical Interconnections

**NOTE**

Refer to the signal converter instruction bulletin for signal converter interconnection wiring.

1. Universal Converter/Driver wiring must agree with the appropriate interconnection diagram. Refer to the following applicable illustration:

- FIGURE 2-2. INTERCONNECTION DIAGRAM FOR UNIVERSAL CONVERTER/DRIVER WITH 50XM CONVERTER
- FIGURE 2-3. INTERCONNECTION DIAGRAM FOR UNIVERSAL CONVERTER/DRIVER WITH CD1 CONVERTER
- FIGURE 2-4. INTERCONNECTION DIAGRAM FOR UNIVERSAL CONVERTER/DRIVER WITH REMOTE CONVERTER
- FIGURE 2-5. INTERCONNECTION DIAGRAM FOR UNIVERSAL CONVERTER/DRIVER WITH CONTINUOUS SUBMERGENCE FLOWMETER
- FIGURE 2-6. INTERCONNECTION DIAGRAM FOR UNIVERSAL CONVERTER/DRIVER WITH ACCIDENTAL SUBMERGENCE FLOWMETER

2. Minor differences exist between terminal functions of the 50XM version of this product and a standard 50XM converter. These are as follows:

- The alarm terminals are a solid state switch which will conduct current upon the initiation of an alarm condition. This arrangement will pass up to 50 mA dc from terminal V5 (+) to V6 while operating at up to 28 volts.
- When indicated flow is in the forward direction, the direction relay will establish a connection between terminals 44 and 45. For reverse flow, terminals 45 and 46 will be connected by the relay.

3. Refer to the applicable signal converter instruction bulletin for additional signal converter information.

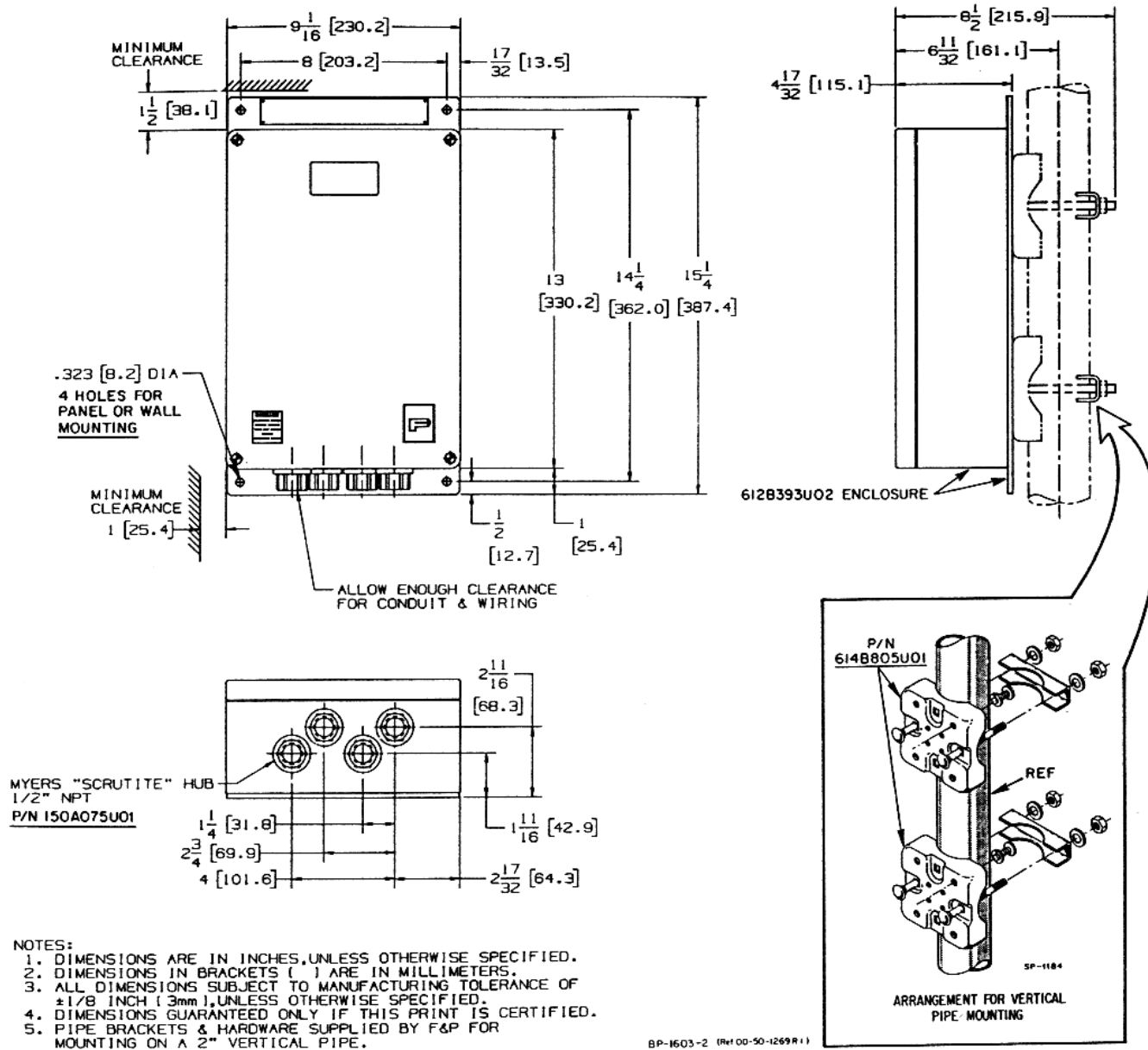
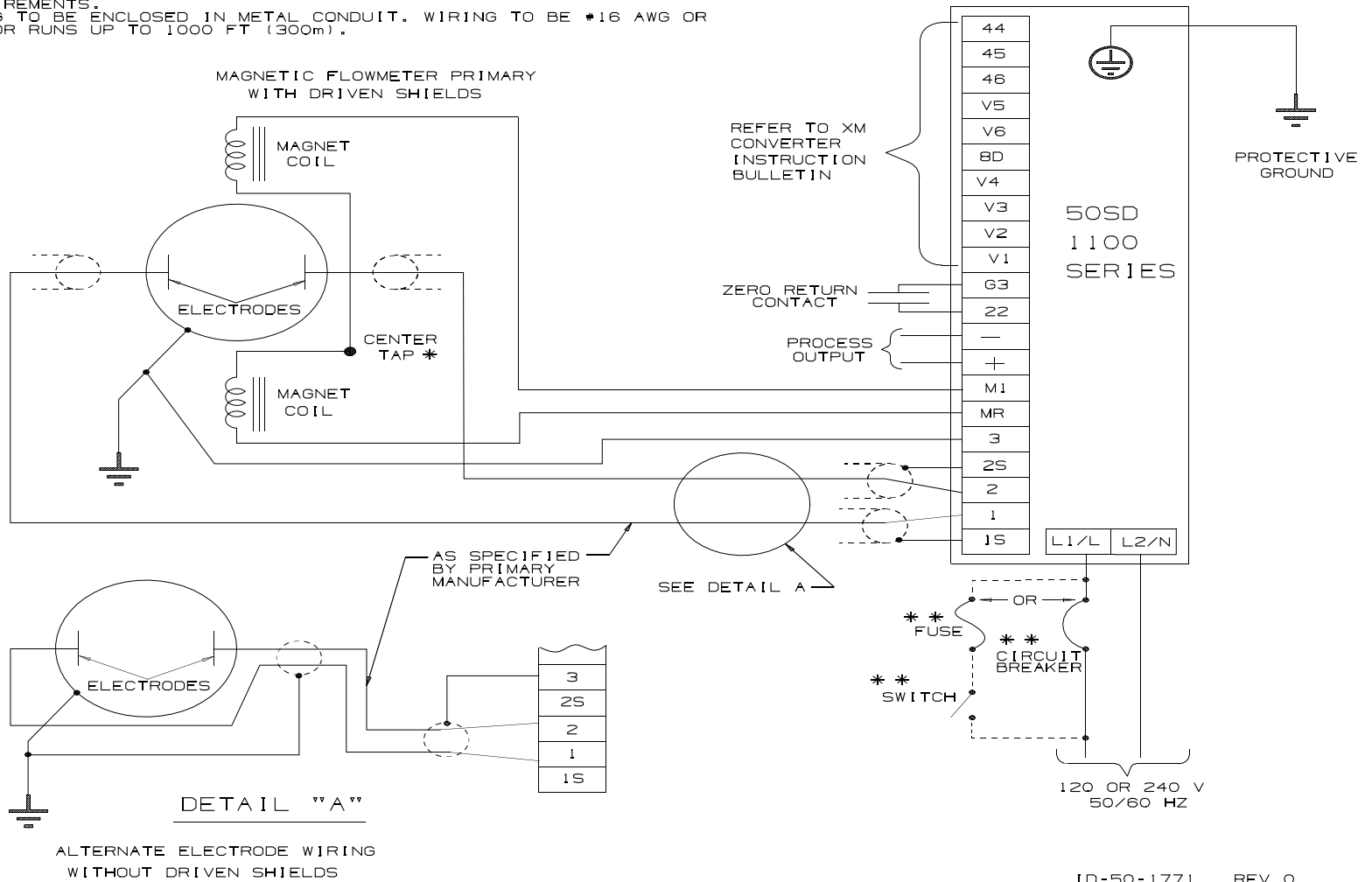


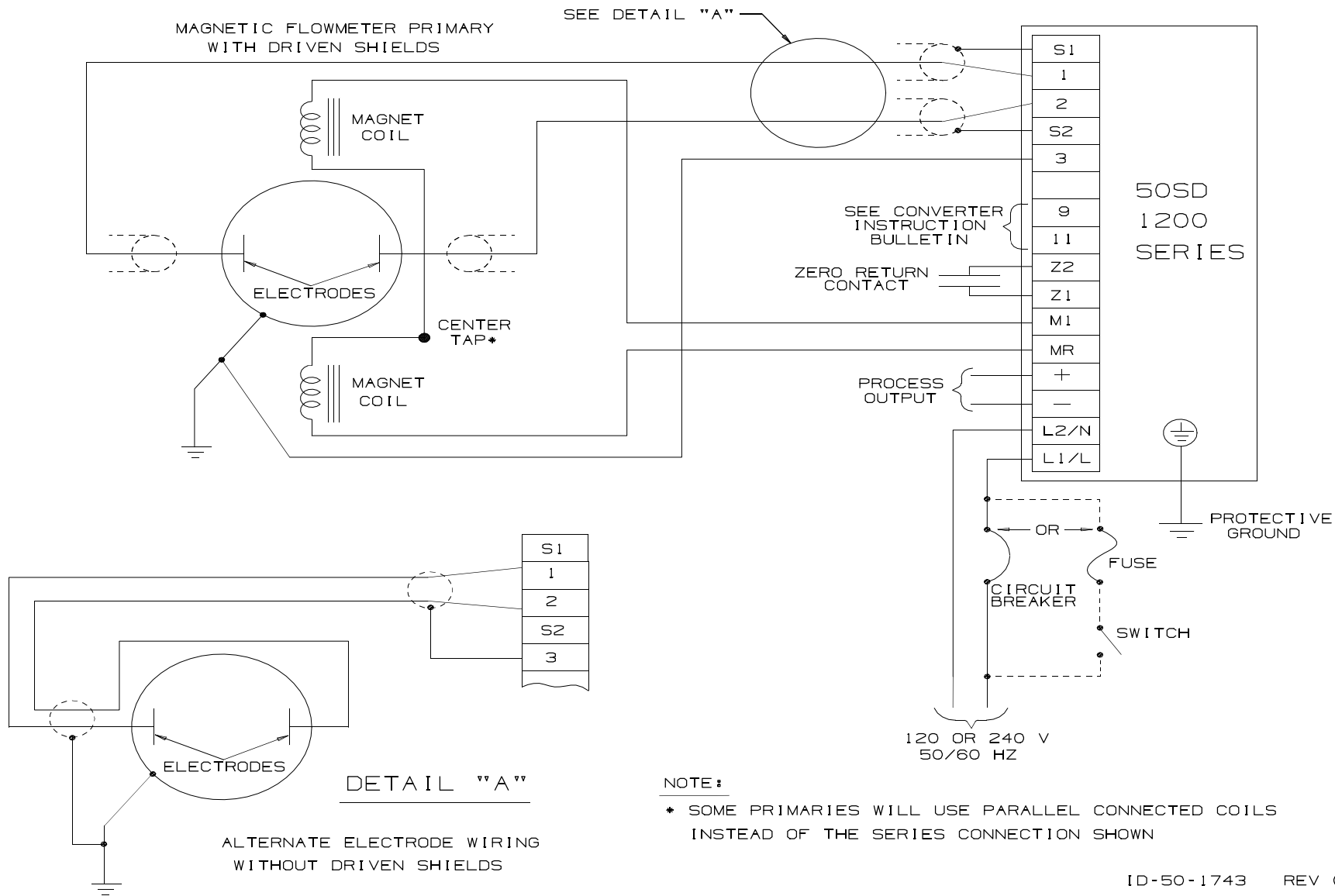
FIGURE 2-1. OUTLINE DIMENSIONS AND MOUNTING ARRANGEMENT

- NOTES:
1. \* SOME PRIMARIES WILL USE PARALLEL CONNECTED COILS INSTEAD OF THE SERIES CONNECTION SHOWN.
  2. \* \*INDICATES SUPPLIED BY CUSTOMER.
  3. UNUSED CONNECTIONS MUST BE PLUGGED TO MAINTAIN NEMA 4 RATING.

INSTALLATION REQUIREMENTS:  
 WIRING SHALL COMPLY WITH NATIONAL ELECTRICAL CODE & LOCAL ELECTRICAL CODE REQUIREMENTS.  
 ALL WIRING TO BE ENCLOSED IN METAL CONDUIT. WIRING TO BE #16 AWG OR HEAVIER FOR RUNS UP TO 1000 FT (300m).

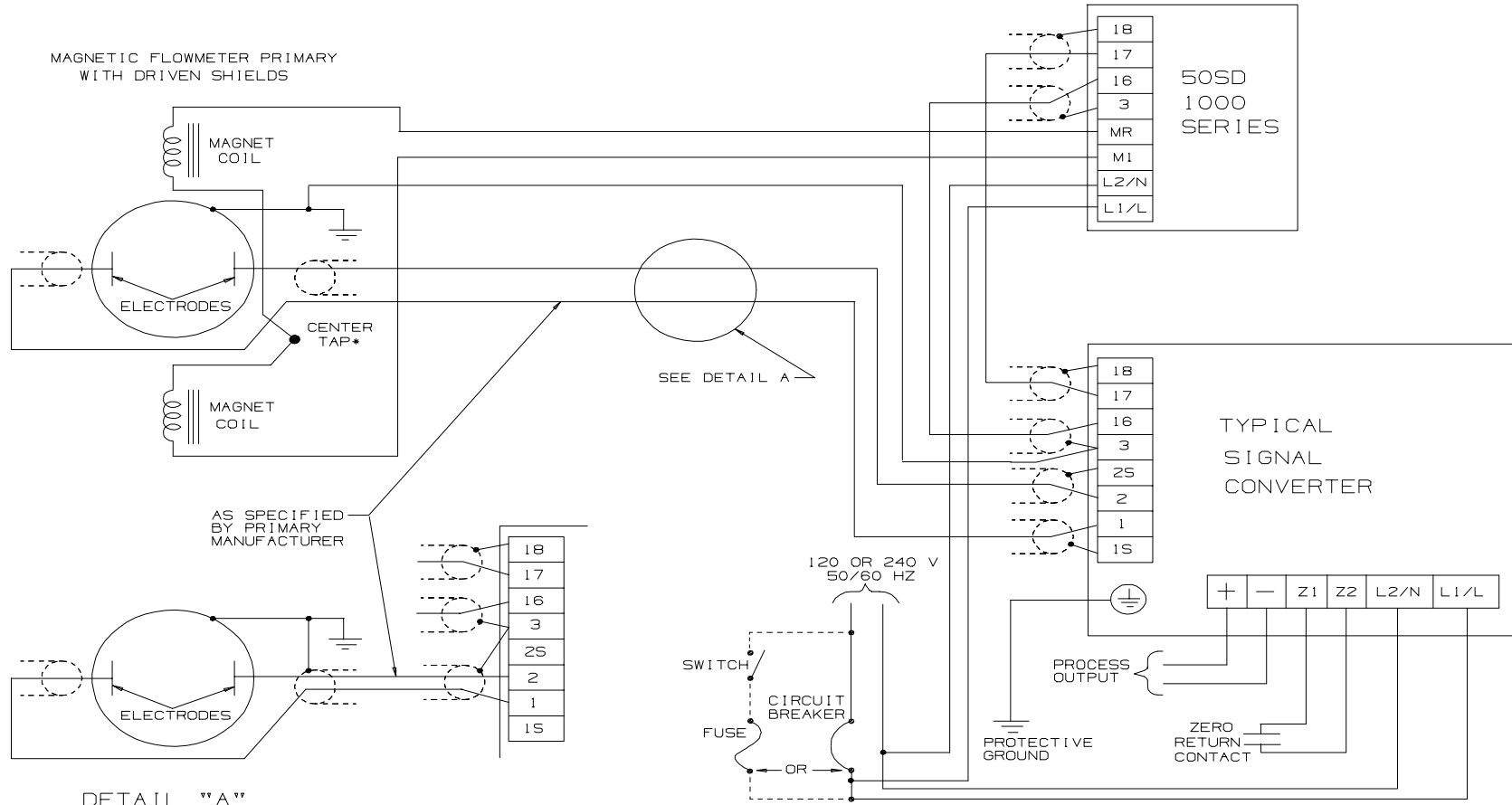


**FIGURE 2-2. INTERCONNECTION DIAGRAM FOR UNIVERSAL CONVERTER/DRIVER WITH 50XM SIGNAL CONVERTER**



**FIGURE 2-3. INTERCONNECTION DIAGRAM FOR UNIVERSAL CONVERTER/DRIVER WITH CD1 SIGNAL CONVERTER**





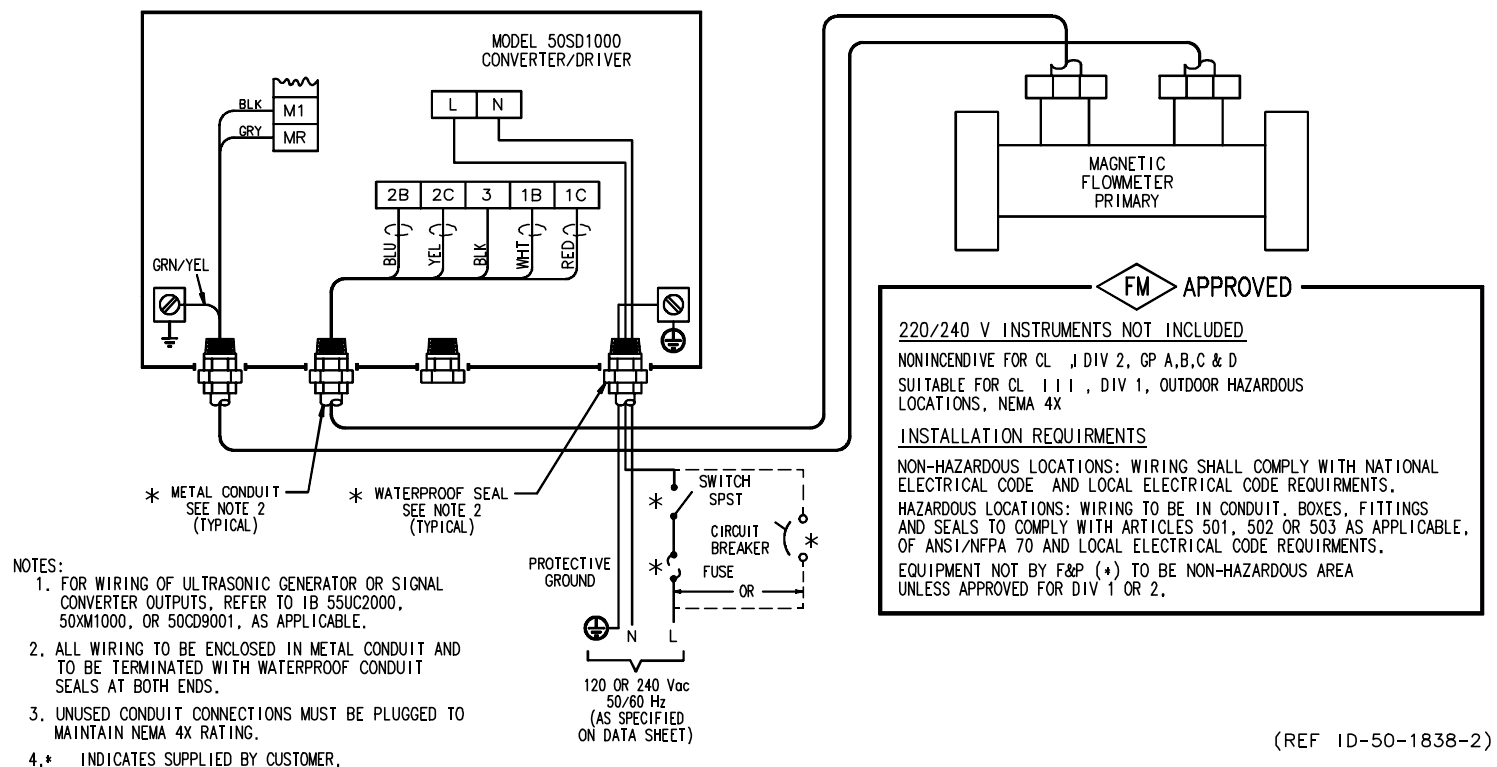
ALTERNATE ELECTRODE WIRING WITHOUT DRIVEN SHIELDS

NOTE:

- \* SOME PRIMARIES WILL USE PARALLEL CONNECTED COILS INSTEAD OF THE SERIES CONNECTION SHOWN

ID-50-1744 REV 0

**FIGURE 2-4. INTERCONNECTION DIAGRAM FOR UNIVERSAL CONVERTER/DRIVER WITH REMOTE SIGNAL CONVERTER**

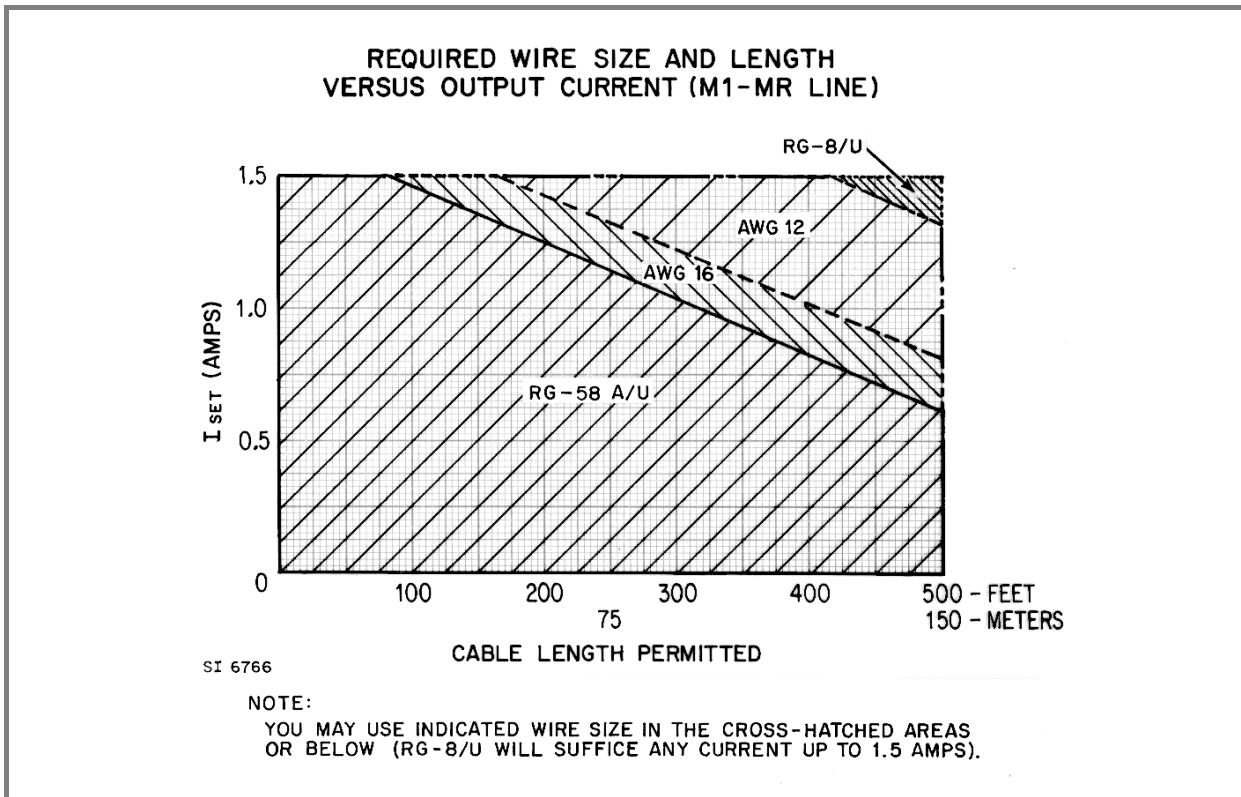


**FIGURE 2-5. INTERCONNECTION DIAGRAM FOR UNIVERSAL CONVERTER/DRIVER WITH  
CONTINUOUS SUBMERGENCE FLOWMETER**



.

.



**FIGURE 2-7. CABLE SIZING REQUIREMENTS**

## 3.0 START-UP AND OPERATION

---

NOTE

Prior to start-up, wiring must agree with the applicable installation diagram and the signal converter instruction bulletin.

### 3.1 New System Installations for Converter/Driver with Flowmeter

If the Universal Converter/Driver being placed into service was shipped as a system with an accompanying flowmeter, no additional setup of the driver or converter is required, provided the proper range was specified at time of purchase. It is only necessary that the converter be wired to its output connections and the associated flowmeter in accordance with the appropriate interconnection diagram (refer to Figures 2-2 through 2-6). Wiring to output devices can be found in the signal converter instruction bulletin.

NOTE

It is important that a particular Universal Converter/Driver and its associated flowmeter remain paired together. The Universal Converter/Driver configuration is different for each size and model number of the related flowmeter. A system accuracy of 1/2% of rate can only be achieved by keeping the Universal Converter/Driver and flowmeter paired.

### 3.2 Continuous Submergence or Accidental Submergence Applications

Universal Converter/Drivers furnished for 6 inch or larger flowmeters may be configured to accept a continuous submergence or an accidental submergence design, but must be wired according to Figures 2-5 or 2-6. The flowmeter zero adjustment potentiometers associated with a continuous submergence flowmeter are located in the converter housing and are labeled (tagged) as "1B", "1C", "2B", and "2C". It is important that these labels are not removed since they are the only method of identification. These red, white, yellow and blue shielded cables coming from the flowmeter must be connected to the proper corresponding terminals, or an unacceptable zero point error will result.

### 3.3 Retrofitting the Converter/Driver in an Existing Installation

Modification information for existing installations can be found in Section 7.0. The universal converter/driver may be applied to flowmeters of other manufacturers, however factory technical personnel must be consulted for such installations.

Verify that the resistance of M1-MR cable is low enough to handle driver output current without significant power loss. Refer to the graph in Figure 2-7.

When retrofitting the Universal Converter/Driver to an existing flowmeter, the new meter calibration factor may alter the indicated flow rate by a few percent, but the system will be repeatable at its new cal factor. If the existing flowmeter contains zero adjustments, they should not be adjusted. However, if the flowmeter is of the continuous submergence type, the zero pots were in a separate housing, the zero procedure noted below must be followed for adjusting the zero pots in the universal converter/driver.

- a. Position the upper adjustment potentiometer associated with wires "1B" and "1C" to the center of its travel (approximately 12 turns from either end).
- b. Set zero using the lower pot associated with the "2B" and "2C" terminals according to the procedure outlined in Sub-Section 3.3.8.

Existing installations typically have acceptable shielding of the electrode wires and may be used provided water has not entered the conduit system. Signal wires for the Converter/Driver must be in installed in metal conduit. Figures 2-2, 2-3 and 2-4 show driven electrode shield applications that are required if process conductivity is less than 20 microsiemens. Consult the factory if driven shield cable is required but not available on site.

**CAUTION**

**Since the Driver Module's output is a floating bridge, under no circumstances should the Driver Module be used with a grounded oscilloscope or DVM. Permanent damage to the Driver module may result if this precaution is not taken.**

**NOTE**

The following Sub-Sections 3.3.1 through 3.3.11 apply to the retrofitting of the Universal Converter/Driver in an existing system.

### **3.3.1 Check Output Current**

When retrofitting, the proper setting of the output current must be made. Current requirements for series 10D1418, 10D1419, 10D1430, and 10D1435 flowmeters can be found in Tables 7-1 and 7-2. Check that SW1 and SW2 are set correctly according to the Tables in Section 7. The values of SW1 and SW2 are shown next to the switches. Each incremental position of switch SW1 causes a 0.1 Amp increase in driver current while each position of SW2 causes the driver current to increase by 0.01 Amps. Their values are additive up to 0.99 Amps. Note that if driver currents between 1.00 and 1.50 amps are required, SW3 position 1 must be placed in the open position. This adds 0.8 amps to all SW1 & SW2 settings. If the output current setting is not correct, it must be changed.

### **3.3.2 Check Reference Voltage**

When retrofitting, the proper resistor R56 must be installed on the output board to generate the correct reference voltage. Compare the R56 value in your Universal Converter/Driver with Table 3-1. If the value is not correct replace the resistor as described in Section 3.3.2.1.

R54 on the output board may also require adjustment as described in Section 3.3.2.2.

#### **3.3.2.1 Selection of Proper Value of R56**

When retrofitting, the following procedures which describe the selection of R56 and the adjustment of R54 must be done so that driver output current set by switches SW1 and SW2 will develop a nominal 70 mV reference for the Signal Converter.

The value of R56 shall be chosen from the Table 3-1, and if a new value is required, the R56 residing in the output board must be desoldered and a new one soldered in its place. A load resistance is required for the driver. This load should be obtained by connecting the driver to the flowmeter with which it is to be used. The proper settings of SW3, positions 2, 3 and 4, must be determined by either observation of the driver current output (reference voltage) with an oscilloscope (see Figure 4-2) or observation of the CR3 LED at an excitation frequency of not more than 7.5 Hz (at higher rates, the flashing will be so rapid that the LED will appear to be constantly illuminated.) The CR3 LED is located on the Driver Module board and should be blinking. If there is any doubt about the SW3 settings, place 2, 3 and 4 all in the "on" position.

**NOTE**

Since DIP switches from different manufacturers may differ in their markings, the markings "closed" and "open" may appear instead of the markings "on" and "off" respectively.

**TABLE 3-1. SELECTION OF R56 VALUE**

<b>Driver Output Current</b>	<b>R56 Value (<math>\Omega</math>)</b>	<b>Part Number</b>
.05 - .19	1.50	161S176U12
.20 - .69	0.38	161S176U04
.70 - 1.50	0.10	161S176U11

### 3.3.2.2 Adjustment of R54

When retrofitting, calculate the effective reference resistance value ( $R_{ref}$ ) as a function of  $I_{set}$  (the driver output current to be set) as follows:

$$R_{ref} = 70 \text{ mV}/I_{set}$$

Example:  $I_{set} = .74 \text{ A}$   
 $R_{ref} = 70 \text{ mV}/.74 \text{ A}$   
 $R_{ref} = .0946 \text{ ohms}$

Calculate  $E_{ref}$  as follows:

$$E_{ref} = (R_{ref}/R56 \times (V16-3))$$

example:  $R_{ref} = .0946 \text{ ohms}$  (from above)  
 $R56 = 0.10 \text{ ohms}$   
 $V16-3 = 73.5 \text{ mV}$  (measured)  
 $E_{ref} = (.0946 \text{ ohms}/0.10 \text{ ohms}) \times 73.5 \text{ mV}$   
 $E_{ref} = 69.53 \text{ mV}$

- Turn R54 fully clockwise. Adjust SW1 and SW2 to obtain the proper set current ( $I_{set}$ ) [Refer to Section 3.3.1].
- Apply power to both converter and driver.
- For 50XM converters, temporarily set the debit excitation frequency to 7.5 Hz.
- Observe the CR3 LED on top of the driver. It should pulse.
- Open SW4 positions 1 and 2 on the driver.
- The CR3 LED should now be off.
- Manipulate positions 2, 3 and 4 of SW3 if the above conditions cannot be satisfied.
- Note the voltage reading of a DVM connected from terminals 16 (+) to 3. Refer to this voltage as V16-3.
- Adjust R54 until the calculated value of  $E_{ref}$  is obtained within tolerance of +0.14 mV.

**NOTE**

This procedure may have to be repeated several times to achieve the desired results.

- Once correct, a small amount of nail polish can be used to seal the R54 position.
- Close SW4 positions 1 and 2.
- If drive frequency was changed, reset to appropriate setting.



### 3.3.3 Start-Up

If both the output current and reference voltage are set correctly, and driver module switches are set properly, power up the converter and driver.

If a universal converter/driver does not operate properly when first powered, the following items should be checked. **Refer to the applicable Converter Instruction Bulletin for additional information.**

- For the Driver Module, make sure the self test switch SW4 on the lower printed circuit board is in the run mode (1 and 2 closed, 3 and 4 open).
- Verify that all hook and dip switches are in their operating modes. (For 50XM Converters, check the driver feedback jumper (Figure 3-1).
- For CD1 Converters, check that the range pot jumper is in place and that the Converter is set to deliver the expected output (4-20 mA or 0-1000Hz).
- Recommended equipment for bringing a system on line:
  - a. extra fuses - 0.5 amp slow-blow 5 x 20 mm
  - b. DVM with a resolution of 10 microvolts (Keithly 172 or equivalent)
  - c. a calculator
  - d. oscilloscope (optional)

**CAUTION**

Since the Driver Module's output is a floating bridge, under no circumstances should the Driver Module be used with a **grounded** oscilloscope or DVM. Permanent damage to the Driver module may result if this precaution is not taken.

### 3.3.4 Set the required drive frequency on 50XM Converters

Refer to the 50XM Instruction Bulletin.

### 3.3.5 Determine the meter calibration factor (cal-factor) as follows

This number is expressed as gallons per minute at a velocity of 33.33 feet/second. If the meter factor (effective meter diameter) is known, the cal factor may be calculated by squaring the meter factor (expressed in inches), and multiplying that number by 81.6.

For example, if the meter factor is 4.00 inches, then the cal factor is:

$$\begin{aligned}\text{Cal Factor} &= (4.00 \times 4.00) \times 81.6 \\ &= 1305.6 \text{ gpm}\end{aligned}$$

This number represents the actual flow through the flowmeter at a liquid velocity of 33.33 feet/second. Refer to the appropriate flowmeter instruction manual to set the proper span for the application. The remainder of the converter setup may now be completed as described in its specific instruction manual.

### 3.3.6 Set span

Refer to the applicable signal converter instruction bulletin.

### 3.3.7 Setting System Zero

Check to see that the magnet coils are wired properly. If the coils are wired in opposition, they will generate bucking flux fields, and little or no flow signal will be produced at the electrodes. This point should be given careful attention if coil wiring is disconnected and subsequently changed. In order for the system to operate within specification, it is mandatory that a system zero be established before actual process measurement commences. When the system has been properly wired, process flow should be stopped and the metering tube completely filled with process liquid. It is important that any zero adjustments in the flowmeter be identified. There may be one, two, or sometimes no potentiometers. It is best to adjust only one pot if possible. If a proper zero cannot be achieved by moving only one adjustment, then move the first one to the extreme which gives the best zero and then operate the second adjustment (if present). Refer to the applicable signal converter instruction bulletin to supplement the following discussion.

1. For systems with 50XM signal converters:
  - The low flow cutoff should first be set to 0.0% of span.
  - The "manual" mode should be used to set the system zero adjustment to zero (refer to converter instructions).
  - The primary zero adjust pot(s) should be set so that the display indication is as close to zero as possible.
  - The system zero adjust should be set while in the "automatic" mode.
  - For systems without any adjustments, the system zero should be used in the "automatic" mode. A signal of up to 0.5 meters/sec (1.5 ft./sec) is available in this mode, which should suffice for most applications.
2. For Systems with CD1 Converters:
  - The Converter output should be elevated by placing a jumper between terminal "16" and TP-2.
  - The J3 range jumper should then be removed from TP-4 and the output indication noted.
  - Replace J3 and turn the primary zero adjust pot(s) until the converter indication is the same as that previously noted.
  - If the flowmeter has no means of zero adjustment and these two readings differ by more than 0.1% of span, consult the Technical Support Department for further instructions.

### 3.3.8 Proceed with flow measurement

Start flow through the process piping system that includes the flowmeter. Allow a nominal flow through the pipeline for several minutes to purge entrapped air. The pipeline must be full for accurate flow measurement.

### 3.3.9 If the meter is not operating, check the following

1. Electrode signal reversal is a common problem.
  - a) The 50XM Converter is bi-directional, the display will indicate such a condition.
  - b) For CD1 Converters, elevate the converter by connecting "16" and TP-2 and note if the output signal goes below 74.3% of span. If this occurs, the electrode leads should be reversed.
2. Verify that the system has been properly zeroed according to the procedure outlined in Sub-Section 3.8. Zero errors may result in unacceptable measurement errors, particularly at low range settings.

### 3.3.10 Special applications information

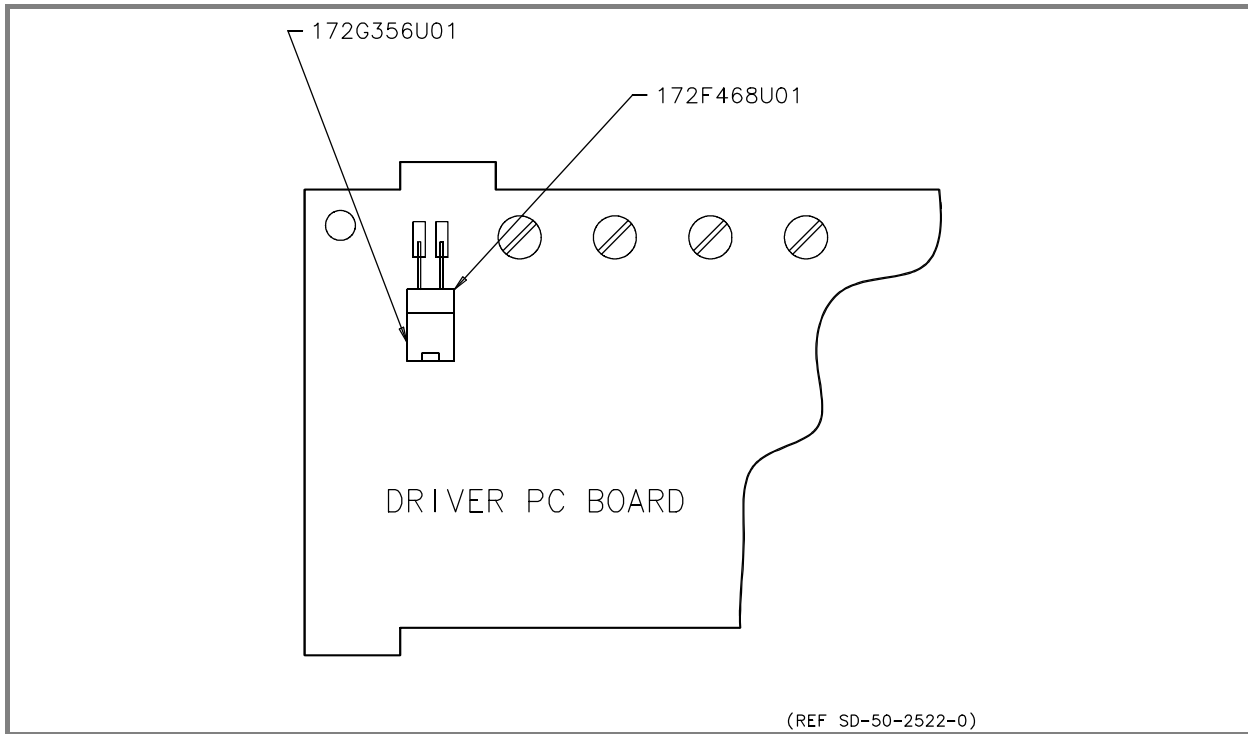
1. This product uses a modified 50XM Converter with a driver feedback jumper on the magnet driver assembly. Before connecting this module to any flow simulator, make sure that the driver feedback jumper is removed; otherwise damage to the simulator may result (See Figure 3-1). If the 50XM Converter is replaced, the feedback jumper must be installed on the replacement Converter.
2. The LED operation indicator is best observed at 7.5 Hz on 50XM systems (at higher rates, the flashing will be so rapid that the LED will appear to be constantly illuminated.) This may be done by temporarily moving switch S101 on the 50XM Converter analog printed circuit board to the 7.5 Hz position. It must then be placed back to the 15 Hz position (if applicable), or an error message may result.
3. If the product is to be used in an application where the output coil power is less than 2 watts, it may be necessary to use the 20 volt position by placing the W2 jumper of the universal converter/driver across positions 1 and 2. If this does not produce a stable output, it may be necessary to place a power resistor in series with the coils at the M1 terminal. The proper resistance value must be determined by trial and error. An ohmic value of  $10/I_{set}$  where  $I_{set}$  is in amperes will be a good starting point.
4. While the universal converter/driver incorporates reliable solid state design features, it may be permanently damaged if certain conditions exist for any length of time.

To avoid damage:

- Do not disconnect the magnet coil circuit when the driver module is powered; severe transients and arcing will result.
- Do not short circuit the universal converter/driver.
- Do not operate the universal converter/driver if the LED operation indicator is constantly illuminated (at 7.5 Hz). This most likely indicates the stability switches are set incorrectly and the unit will draw excess power. Damage and/or fuse blowing may result.

5. The universal converter/driver is designed to drive inductive loads. Purely resistive loads cause the unit to oscillate, particularly at low levels of output power. The following resistor (connected across M1 and MR) may be used to load the unit at 0.8 amperes or more to assist in trouble shooting of the universal converter/driver:

Clarostat part# VP25KA-10  
(10 ohms, 25 watts)



**FIGURE 3-1. DRIVER FEEDBACK JUMPER ON 50XM1000N CONVERTER  
(located on vertical PC board behind power connector)**

## **4.0 FUNCTIONAL DESCRIPTION OF DRIVER MODULE**

---

### **4.1 Description**

Refer to Figures 4-1 and 4-2 to supplement the following discussion.

The universal converter/driver permits a constant current output of between 0.05 and 1.5 amperes to be set using a pair of digitally encoded switches coupled to a stable ac reference voltage. A synchronizing gate pulse is applied from the signal converter through two isolated inputs 17 and 18. A change in the logic state of the gate pulse will reverse the direction of the output current. The circuitry employs error detection and pulse width modulation (PWM) to then force the output current to equal that of the setting. Initially, 40 volts is applied to the magnet load. The voltage stabilizes when the correct current has been reached. This initial voltage may be changed to 20 when output voltage requirements are low.

A stable Integrated Circuit (IC) regulated voltage supply is connected to the output setting circuit, where a switch controlled digital attenuator network provides an input to one side of the error amplifier. For settings greater than 0.99 ampere, a separate switch is used to add 0.8 ampere to the other required settings.

All current passed through the magnet coils is sensed in  $R_s$ , whose voltage is also directed to the error amplifier. The error amplifier applies a gain of approximately 1000 to any difference between the set value and the  $R_s$  voltage. Error amplifier stability tends to vary as load reactance changes, and a stabilizing network with switch set component values has been included to prohibit any oscillation. Each type of flowmeter will require specific settings in order for the driver to operate properly, as oscillation in the error amplifier causes consumption of excess power and will overheat components.

The output of the error amplifier is fed to what is shown as PWM (pulse width modulation) circuitry. This block will convert any difference between the set and the output currents to a 60 kHz pulse train whose duty cycle represents this difference voltage. This PWM is then used to switch a high power VMOS driver transistor, whose purpose is to apply the unregulated voltage in pulsed form to the driver's output. The driver signal is passed through a 2 stage L/C low pass filter to remove 60 kHz components and sized so that its time constant will not introduce undesirable frequency components into the error amplifier.

Attached to the filter output is a block called "operation monitor". Its purpose is to monitor the AC component of the filter's output for the presence of unwanted oscillation, such as that caused by an improper setting of the stability adjust network. The circuit's output, an LED, also indicates the application of the "zap" voltage to the coils twice during each cycle of the gating pulse. Thus, during normal driver operation, the LED should be observed to blink at 7.5, 15, or 30 times per second, depending on the converter's excitation frequency (at rates above 7.5 the flashing will be so rapid that the LED will appear to be constantly illuminated.) If the LED is either on uninterruptedly or does not blink steadily, a fault condition, which must be corrected, exists somewhere in the driver.

The output bridge is the final block preceding the coils. It consists of two pairs of complementary power MOS transistors connected in an "H" type configuration. A change in the state of the gating pulse causes diagonally opposite transistors in the bridge to conduct, thereby permitting application of an alternating waveform to the magnet drive terminals (M1 and MR). The gating signal, applied to

terminals 17 and 18, is optically coupled to the output bridge and will function properly with a wide range of input voltages.

A resistance network which will establish the proper converter reference voltage level of +/- 70 millivolts at terminal 16 and 3 is included on the driver. It consists of an  $R_x$  low value current sensing resistor placed in series with the coils and has an adjustable voltage divider across it. This permits "K" factor adjustment over a 6 to 1 range. The value of  $R_x$  must be changed to accommodate the driver's full 30 to 1 range of output current.

The self test block, interposed between the gating signal and the output bridge, may be used to disconnect the normal gating arrangement so as to select either polarity of the output bridge (refer to Section 6.2.2). This is useful when verifying output power, setting stability or reference voltage adjustments, or trouble shooting. All circuitry within the driver, including the gating opto coupler, is exercised by the self test circuitry.

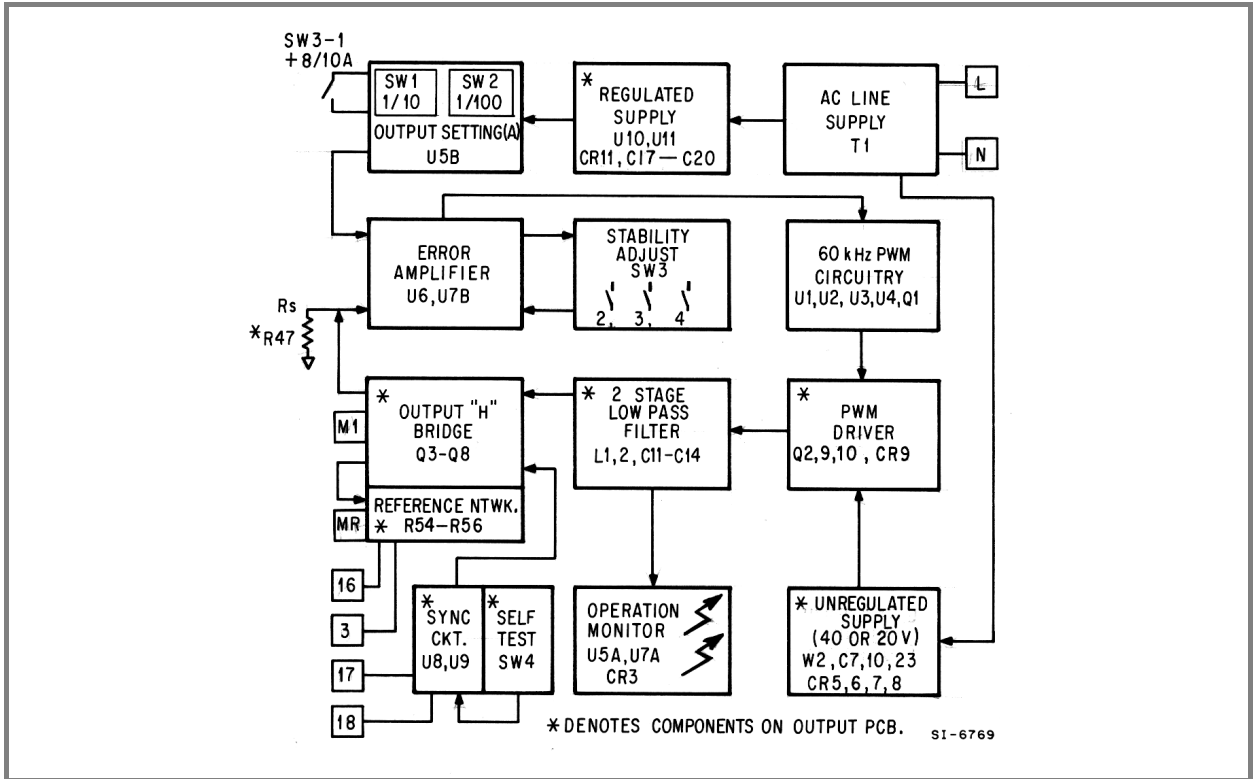


FIGURE 4-1. DRIVER MODULE BLOCK DIAGRAM

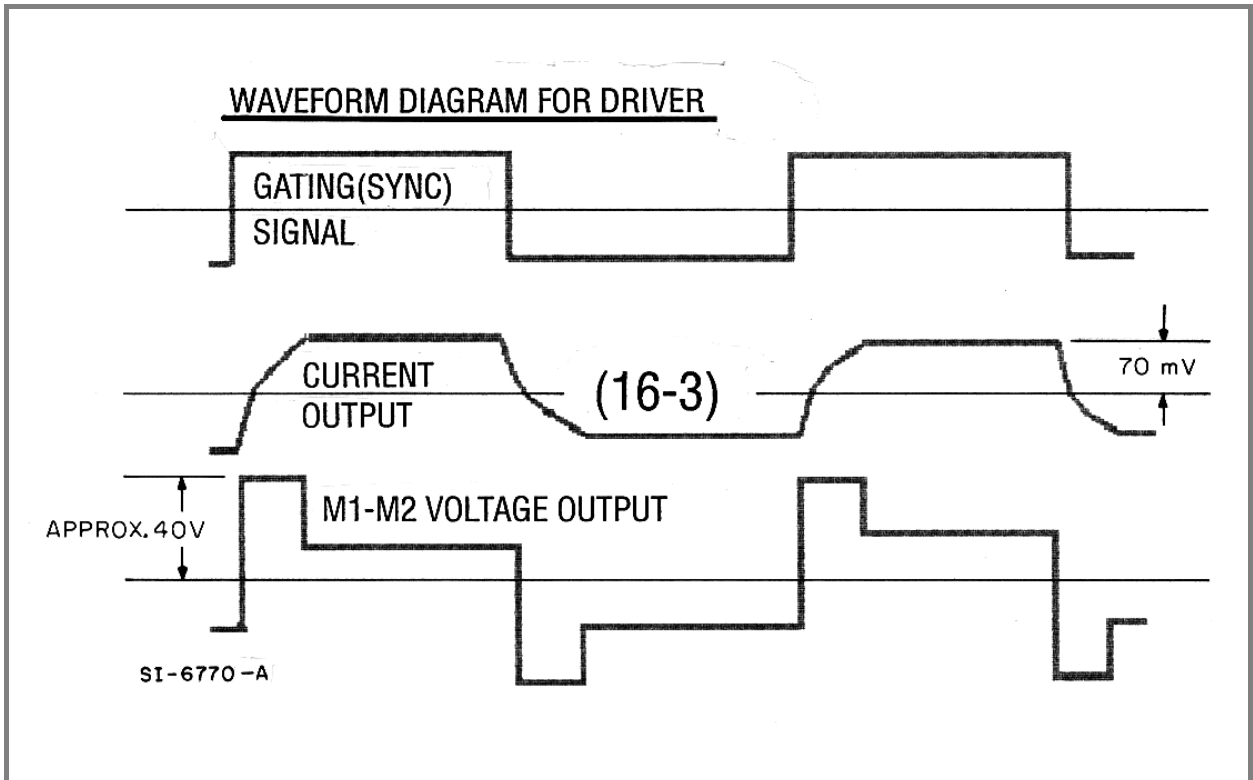


FIGURE 4-2. DRIVER MODULE WAVEFORM DIAGRAM

## 5.0 CALIBRATION

---

### 5.1 General

If the flowmeter requirements were specified at time of order, the Universal Converter/Driver has been factory calibrated and does not normally require realignment when received. The following procedure can be used to facilitate verification of system accuracy on a periodic basis as suitable for the particular application. This procedure can also be used if the need arises to change system operating parameters and confirm system accuracy at the new span setting or for verification of range alignment following repair or replacement of a module. Refer to Figure 5-1 or 5-2 for the appropriate calibration diagram.

The following test equipment is used for verification of alignment or recalibration.

- 1) MAG-X<sup>®</sup> Calibrator (Type 55MC1020)
- 2) Digital Multimeter with +0.05% accuracy and a minimum of 10 Megohms input impedance on a 10 Vdc range.
- 3) Electronic Frequency Counter with 10 second sample period.
- 4) Oscilloscope (optional)

Always disconnect the power source from the flow metering system before removing the instrument access cover. Interconnection wiring to the terminal boards must be disconnected to permit addition of test wiring. All wiring should be identified (by terminal number) to assure proper reconnection.

The Calibrator unit, required for alignment and calibration of the signal converter, is a precision, compact, portable test instrument designed specifically to produce a simulated process signal like that generated by an operating flowmeter at specific flow velocities. The Model 55MC1020 Calibrator has four digital (0-9) thumbwheel switches that permit selection of continuous direct reading settings of either 0.01 to 99.99 feet per second or 0.001 to 9.999 meters per second. Accuracy of the calibrator is +0.15% of setting at reference conditions.

If adjustment of the signal converter is necessary, refer to the procedure in the applicable signal converter instruction bulletin.



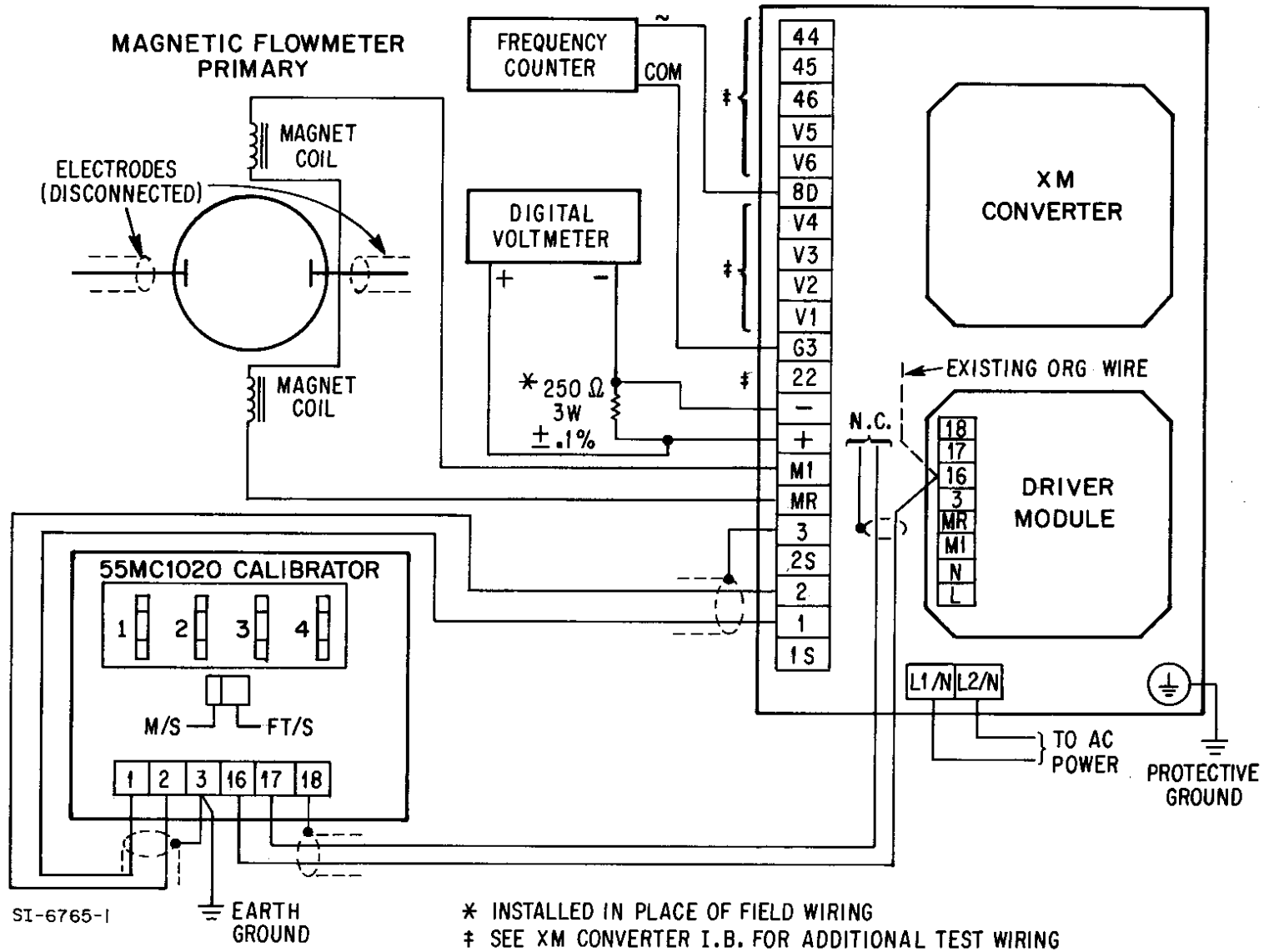
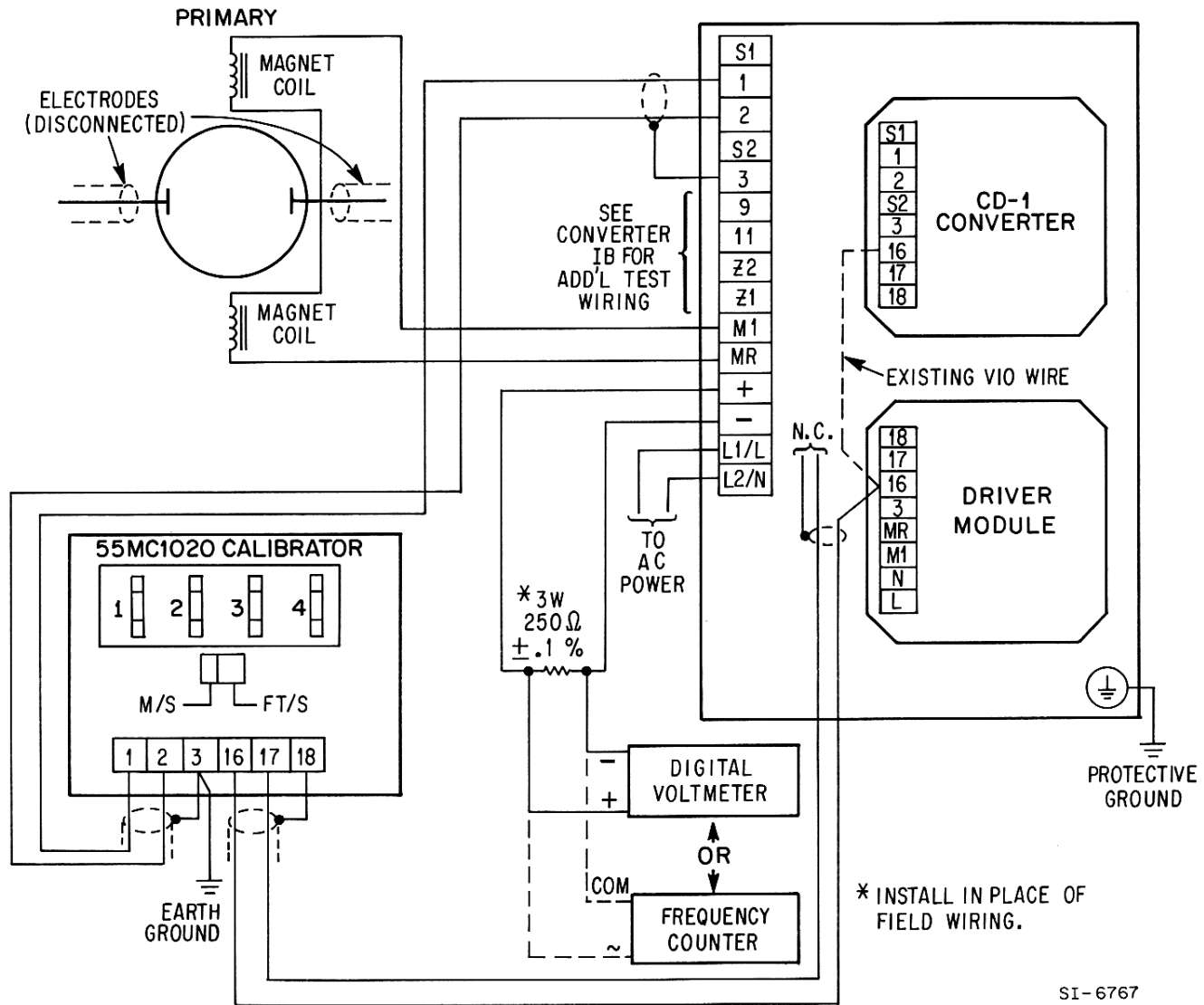


FIGURE 5-1. CALIBRATION DIAGRAM FOR 50XM CONVERTERS



SI-6767

FIGURE 5-2. CALIBRATION DIAGRAM FOR CD1 CONVERTERS

## 6.0 MAINTENANCE

---

### 6.1 General

The Universal Converter/Driver uses both IC and Large Scale Integration (LSI) components. Therefore, due to the complexity of troubleshooting integrated circuit devices, maintenance beyond the assembly level is generally not recommended. Caution must be used when connecting test probes; an accidental short circuit may damage or destroy an integrated circuit device. Therefore, only trained electronic technicians who are familiar with Complimentary Metal Oxide Semi-conductor (CMOS) technology and have a background in logic and gating circuitry should be permitted to service this equipment.

In the event of a malfunction of a module in the Converter/Driver Assembly, a replacement module can be quickly substituted for the defective assembly, thereby minimizing system down time. Servicing by substitution of spare assemblies is generally more economical than stocking a large variety of IC chips, transistors, diodes, etc. Also, test equipment requirements and the level of technical expertise necessary are minimized. Should any question arise regarding the proper procedure for solving a problem, contact the nearest service facility for technical assistance.

When communicating with the factory in regard to a question, it is important to reference the complete instrument serial number and model number. This information is provided on the specification sheet supplied with the Universal Converter/Driver and on the instrument data tag.

### 6.2 System Troubleshooting of the Universal Converter/Driver

**NOTE**

The following procedures must be performed in sequence. This section assumes that the system has previously operated properly. Refer to Section 3.0 if the system has never been operational.

**CAUTION**

**Since the universal converter/driver's output is a floating bridge, under no circumstances should troubleshooting of the Universal Converter/Driver be attempted using a grounded oscilloscope or DVM. Permanent damage to the Universal Converter/Driver may result if this precaution is not taken.**

**6.2.1 Troubleshooting the System**

<b>TEST PROCEDURE</b>	<b>WHAT TO LOOK FOR</b>	<b>IF YES</b>	<b>IF NO</b>
1a. For systems with 50XM Converters: Set low flow cutoff to 0.0% and place jumpers between terminals 1, 2 and 3 of customer terminal block. Leave existing wiring in place.	Display, pulse and analog outputs should go to less than 0.1% of span.	Electronics most likely OK. Check flowmeter (refer to step 5).	Check coil drive (step 2).
1b. For systems with CD1 Converters: On the converter, place jumpers between terminals 1, 2 and 3. Place a jumper between 16 and TP2.	Pulse and analog outputs should go to 74.3% of span $\pm 0.5\%$ .	Electronics most likely OK. Check flowmeter (refer to step 5).	Check coil drive (step 2).
1c. For other converters, contact the factory.			
2. Leave all jumpers connected as in 1a or 1b and check for reference voltage (coil current).	Using an oscilloscope, note if a reference voltage of $\pm 70$ mV is present at terminals 16 of the driver module and 3 of the customer connection.	Electronics not operating properly. Replace converter.	Check coil drive voltage (step 3).
3. Check for drive voltage at terminals M1 and MR of customer terminal block.	Using an oscilloscope, note if there is a $\pm 40$ volt square wave at M1 and MR	Check for open coil wiring. Repeat step 1a or 1b if open wiring is found.	Check all fuses (step 4).
4. Check all fuses.	Check for blown fuses.	Replace any blown fuses and repeat step 1. If fuse blows again, electronics are defective and should be replaced.	Electronics are defective and should be replaced.
5. Remove any previously installed jumpers. Using a Simpson 260 VOM (set at the R x 10,000 range) or equivalent, check resistance between terminals 1 and 3, and between 2 and 3 (-) at the customer connection block.	Does the resistance immediately drop toward zero and then increase to infinity in approximately 10 seconds? Both checks should respond in a similar manner.	Check for the following: 1. poor or missing grounds 2. wiring between flowmeter and converter 3. noise caused by excessive amounts of air or solids in the pipeline 4. non-full flowmeter 5. Repeat step 1 if any of the above is identified and corrected.	Check for opens or shorts in electronic wiring. Remove flowmeter or electrodes and check for coating or corrosion. Clean, repair or replace electrodes if required. Refer to the flowmeter instruction bulletin for additional information.

## 6.2.2 Troubleshooting within the Electronics Enclosure

If the steps outlined in Section 6.2.1 have been completed and the problem is traced to the electronics package, the following steps should be followed in order to isolate the problem to either the driver module or the signal converter. Return the system to its normal operating settings when testing is complete.

TEST PROCEDURE	WHAT TO LOOK FOR	IF YES	IF NO
1. Leave field wiring in place and perform a static check of driver module.	Open all SW4 switch positions on driver output board. Use a DVM to measure the voltage between driver module terminals 16 and 3 (-). A reading of $+70 \text{ mV} \pm 2 \text{ mV}$ should be observed. Close positions 3 and 4 of SW4 and the polarity of the voltage should reverse.	Driver module functioning properly. Check gating pulse (step 3).	Check driver output voltage (step 2).
2. Leave field wiring in place and check for driver voltage.	Using a DVM, observe if $\pm 40$ volts is present at terminals M1 (+) and MR as the positions of the self test switches are changed.	Check for open coils or coil wiring.	Check if driver module is in self test mode. If not, driver module is defective and should be replaced.
3. Leave field wiring in place and check for gating pulse.	Using an oscilloscope, observe if a square wave is present at terminals 17 and 18 of the driver module. Amplitude will be $\pm 6$ volts for CD1 converters and $\pm 40$ volts for 50XM converters.	Converter is defective and should be replaced.	Converter or driver module wiring is defective. Check converter (step 4).
4. Disconnect power to the electronics and remove the converter. (If the converter is a 50XM, remove the feedback jumper shown in Figure 3-1.) Check the converter per the applicable instruction bulletin.			

## **7.0 CONVERSION OF MAGNETIC FLOWMETERS**

---

### **7.1 Conversion of Models 10D1418 and 10D1430**

1. AC line power connected to the flowmeter must be disconnected.
2. Place a short circuit across reference terminals "6" and "7".
3. Connect M1 of the converter to L1 of the flowmeter using existing wiring.
4. Connect MR of the converter to L2 of the flowmeter using existing wiring.
5. Connect electrode wiring using existing wiring per the diagram shown in Detail A of Figure 2-4.
6. Find the appropriate coil current setting for the flowmeter in Tables 7-1 and 7-2, and complete converter set-up as outlined in Section 3.0.

### **7.2 Conversion of Model 10D1419**

1. AC line power connected to the flowmeter must be disconnected.
2. Refer to Wiring Modification Figure 7-1.
3. This modification will disconnect the ultrasonic cleaning feature. Contact the factory if its use is absolutely mandatory.
4. Disconnect, cut, and tape any existing wiring going to terminals U1 and U2 at the magnet driver assembly. Remove the black wire from terminal M1 of the driver assembly; place it on terminal U1. Remove the black wire from terminal M2 of the driver assembly and move it to terminal U2.
5. Disconnect the black wire L1 at the magnet driver assembly; move it to terminal U1 at the driver assembly as shown in Figure 7-1.
6. Disconnect the white wire L2 at the magnet driver assembly; move it to terminal U2 at the driver assembly as shown in Figure 7-1.
7. Connect M1 of the converter to customer terminal L1 at the flowmeter (new wiring may be required).
8. Connect MR of the converter to customer terminal L2 at the flowmeter (new wiring may be required).
9. Connect electrode wiring using existing wiring per the diagram shown in Detail A of Figure 2-4.
10. Find appropriate coil current setting for the flowmeter in Table 7-1 and complete Converter set-up as outlined in Section 3.0.

### **7.3 Conversion of Model 10D1435**

1. AC line power connected to the flowmeter must be disconnected.
2. Refer to Wiring Modification Figure 7-2.
3. Remove the magnet coil lead labeled M1 from the driver assembly and place it adjacent to TB2 terminal 5, as shown in Figure 7-2.
4. Remove the magnet coil labeled M2 from the driver assembly and place it adjacent to M1 on TB2, as shown in Figure 7-2.
5. Disconnect the black wire from L1 of the assembly and place it together with the M1 wire (see step 3).
6. Disconnect the white wire from L2 of the driver assembly and place it together with the M2 wire (see step 4).
7. Connect M1 of the converter to customer terminal L1 at the flowmeter (new wiring may be required).
8. Connect MR of the converter to customer terminal L2 at the flowmeter (new wiring may be required).

9. Connect electrode wiring using existing wiring per the diagram shown in Detail A of Figure 2-4.
10. Find appropriate coil current setting for the flowmeter in Table 7-2 and complete converter set-up as outlined in Section 3.0.

#### **7.4 Conversion of Models 10D1465, 10D1475, and 10D1476**

1. The flowmeter must be wired for operation with a remote converter. If this is not the case, refer to the Instruction Bulletin for the appropriate flowmeter to obtain this information. It may be necessary to purchase an adapter plug from the factory in order to complete the conversion.
2. The MR magnet coil wire coming from inside the flowmeter to the terminal block of the printed circuit board in the meter base must be lifted.
3. The white wire originating at the L2/M2 RFI feed through under the converter base cover should be removed. A new piece of white wire should be soldered to this feed through and connected to the MR magnet wire disconnected in step 2. This connection should either be taped securely or accomplished using an insulated splice.
4. Suitable wiring should be used to connect M1 of the converter to M1 (L1) of the flowmeter and MR of the converter to M2 (L2) of the flowmeter.
5. Connect electrode wiring as shown in Figure 2-4. Any wiring previously connected to terminal 16 of the flowmeter must be removed at both the flowmeter and the signal converter.
6. Find the appropriate coil current setting for the flowmeter in Tables 7-3 through 7-5 and complete converter set-up as outlined in Section 3.0.

### 7.5 Coil Current Settings for Models 10D1418 AND 10D1419

**TABLE 7-1. MODELS 10D1418 AND 10D1419**

<b>METER SIZE</b>		<b>I<sub>set</sub> (amps)</b>
<b>inches</b>	<b>mm</b>	
1/10	3	.46
5/32	4	.55
1/4	6	.36
1/2	15	.26
1	25	.16
1 1/2	40	.29
2	50	.31
3	80	.54
4	100	.41

### 7.6 Coil Current Settings for Models 10D1430 AND 10D1435 (also called 10D1465 and 10DX3111 in 30 inch and larger sizes)

**TABLE 7-2. MODELS 10D1430 AND 10D1435**

<b>METER SIZE</b>		<b>I<sub>set</sub> (amps)</b>
<b>inches</b>	<b>mm</b>	
6	150	.60
8	200	.49
10	250	.48
12	300	.62
14	350	.69
16	400	.75
18	450	.86
20*	500	.47
24	600	.54
30*	750	.72
36*	900	.90
42	1100	1.09
48	1200	1.24
54	1300	1.38

Consult factory regarding any meter larger than 54 inches. Serial number must be provided.

\* These sizes were originally supplied with their magnet coils wired in parallel. The coils must be wired in series to operate at the given current settings.



**7.7 Coil Current Settings for Models 10D1465, 10D1475, and 10D1476.**

**CAUTION**

In order to use the Universal Converter/Driver with any of the following flowmeters, the magnet coil wires "MR" coming from inside the flowmeter and "M2" from the standard converter must be removed from their respective terminals on the flowmeter printed circuit board and connected together with an insulated splice or wire nut.

**TABLE 7-3. MODEL 10D1465 & 10DX3111, Sizes 14 - 24 inch**

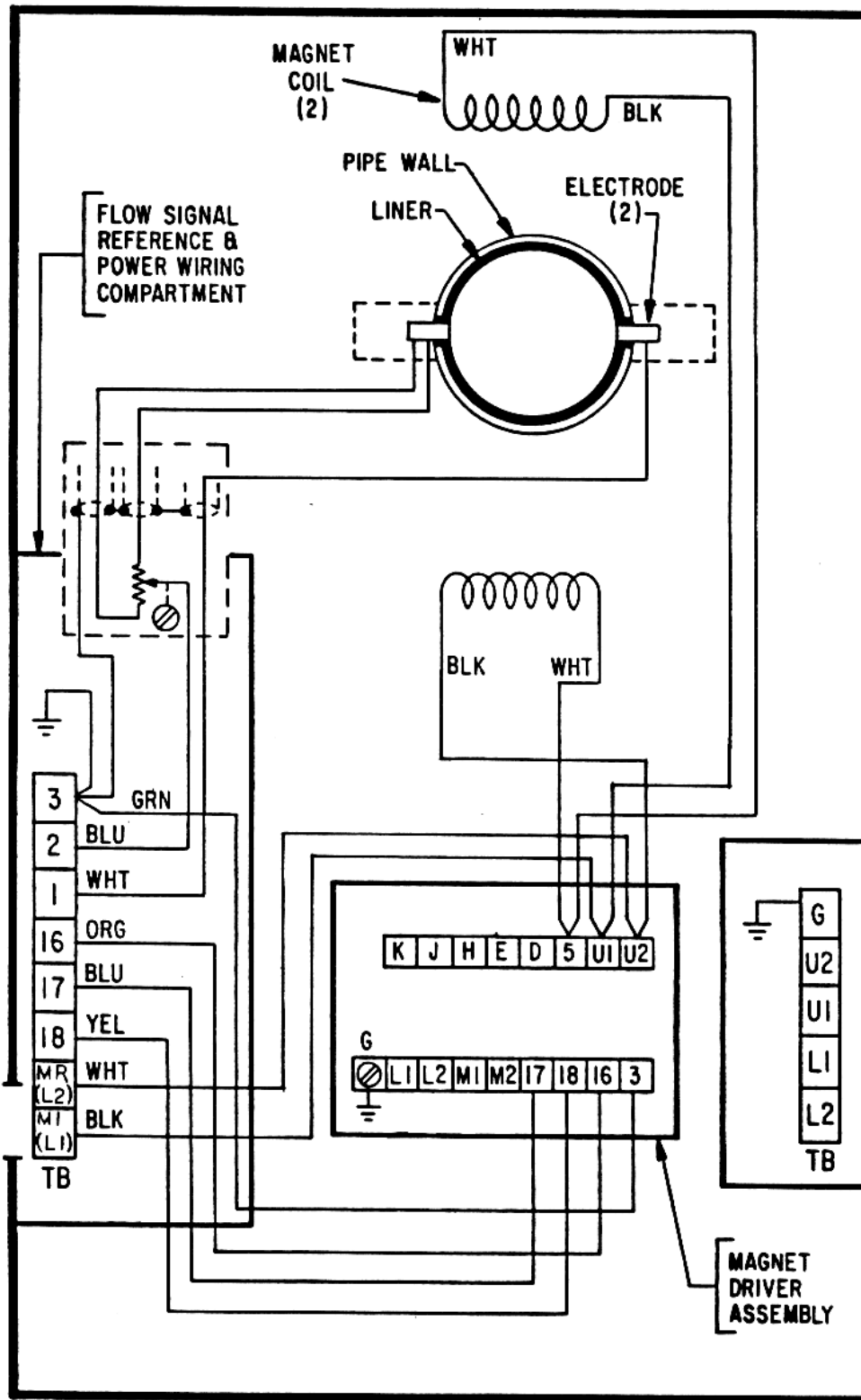
METER SIZE		I <sub>set</sub> (amps)
inches	mm	
1/2	15	.14
1	25	.14
1 1/2	40	.11
2	50	.13
3	80	.11
4	100	.17
6	150	.25
8	200	.30
10	250	.36
12	300	.46
14	350	.50
16	400	.52
18	450	.54
20	500	.46
24	600	.53

**TABLE 7-4. MODEL 10D1475**

<b>METER SIZE</b>		<b>I<sub>set</sub> (amps)</b>
<b>inches</b>	<b>mm</b>	
1/10	3	.22
5/32	4	.25
1/4	6	.24
3/8	10	.25
1/2	15	.25
1	25	.22
1 1/2	40	.13
2	50	.36
3	80	.23
4	100	.28

**TABLE 7-5. MODEL 10D1476**

<b>METER SIZE</b>		<b>I<sub>set</sub> (amps)</b>
<b>inches</b>	<b>mm</b>	
1/25	1	.50
1/10	3	.39
5/32	4	.33
1/4	6	.26
3/8	10	.34
1/2	15	.20
1	25	.17
1 1/2	40	.11
2	50	.36
3	80	.26
4	100	.29



SI-6850 Ref: ID- 50-1758R0

FIGURE 7-1. WIRING MODIFICATION FOR MODEL 10D1419

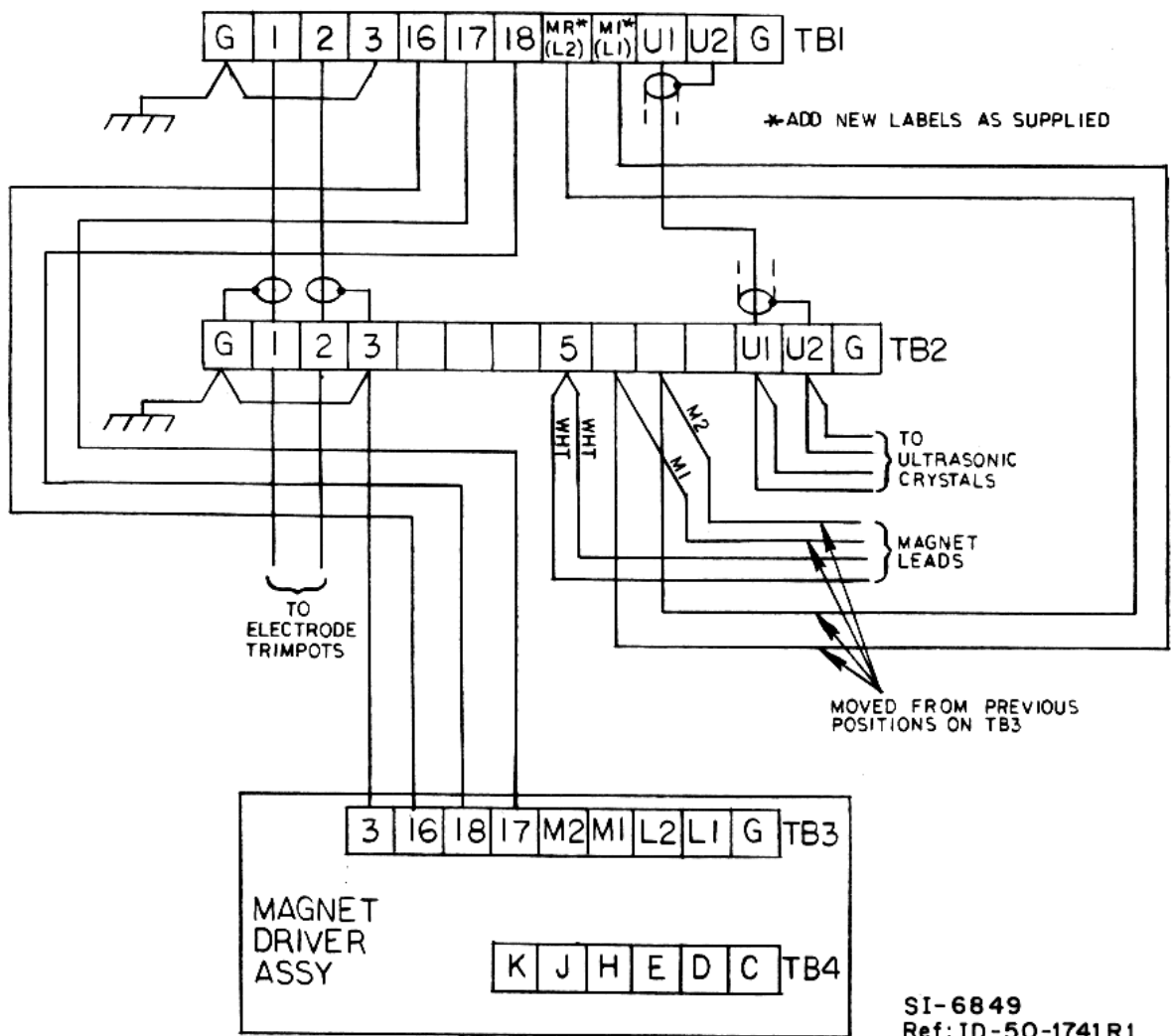


FIGURE 7-2. WIRING MODIFICATION FOR MODEL 10D1435

## 8.0 PARTS LIST

**TABLE 8-1. DRIVER MODULE**

<b>Driver Module 120 V ac, 50/60 Hz</b>	<b>R56 Resistor (<math>\Omega</math>)</b>	<b>Fuse (amp)</b>
698B169U02	161S176U11 (.10)	151A030U11 (0.315)
698B169U03	161S176U04 (.38)	151A030U11 (0.315)
698B169U04	161S176U12 (1.50)	151A030U11 (0.315)
<b>Driver Module 240 V ac, 50/60 Hz</b>	<b>R56 Resistor (<math>\Omega</math>)</b>	<b>Fuse (amp)</b>
698B169U05	161S176U11 (.10)	151A030U15 (0.20)
698B169U06	161S176U04 (.38)	151A030U15 (0.20)
698B169U07	161S176U12 (1.50)	151A030U15 (0.20)

**TABLE 8-2. SIGNAL CABLE**

<b>Part Number</b>	<b>Description</b>
677A921U03	Signal Cable, 30 ft
677A921U05	Signal Cable, 50 ft
677A921U10	Signal Cable, 100 ft
677A921U15	Signal Cable, 150 ft
677A921U20	Signal Cable, 200 ft

**TABLE 8-3. COIL CABLE**

<b>Part Number</b>	<b>Description</b>
677A922U03	Coil Cable, 30 ft
677A922U05	Coil Cable, 50 ft
677A922U10	Coil Cable, 100 ft
677A922U15	Coil Cable, 150 ft
677A922U20	Coil Cable, 200 ft

**NOTE**

Refer to the applicable signal converter instruction bulletin for signal converter parts.

PN24695A



The Company's policy is one of continuous product improvement and the right is reserved to modify the information contained herein without notice.  
© 2003 ABB. All rights reserved. Printed in USA  
[December, 2003]

**ABB Inc.**  
125 East County Line Road  
Warminster, PA 18974 USA  
Tel: 215-674-6000  
FAX: 215-674-7183

**ABB Instrumentation Ltd**  
Howard Road, St. Neots  
Cams. England, PE19 3EU  
Tel: +44 (0) 1480-475-321  
FAX: +44 (0) 1480-217-948

**ABB Instrumentation S.p.A**  
Via Sempione 243  
20016 Pero (Milano) Italy  
Tel: +39 (02) 33928 1  
Fax: +39 (02) 33928 240

**ABB Automation Products GmbH**  
Industriestr. 28  
D-65760 Eschborn Germany  
Tel: +49 (0) 6196 800 0  
Fax: +49 (0) 6196 800 1849