

1 | 13

An ABB technical journal  
for Enclosures and  
DIN rail Products users

# Day <sup>by</sup> DIN



## News and know-how for informed professionals

### **Building automation in the bank**

For the extremely original “orange bank”, adopting the most innovative building automation solutions

### **Wind and windings**

Emission-free electrical energy with ABB miniature circuit breakers

Power and productivity  
for a better world™





## Ring tongue connection. Hold tight, whatever happens



Easy, fast, captive: S 200 PR and SU 200 PR are high-performance miniature circuit breakers with ring lug connections conforming to UL, CSA, and IEC standards. The integrated captive connection screw simplify assembly, saves time and guarantees optimum protection for the ring lug connection. The miniature circuit breakers are a valuable addition to the well-known System pro M compact® range which allow all UL and CSA-approved components to be combined easily with the new range. For more information, see [www.abb.com](http://www.abb.com)

Power and productivity  
for a better world™





Technological restyling for the Julius Caesar room of the Campidoglio in Rome. (36)

# Day by DIN 1|13



**Emanuele Tosatti**  
Product Marketing Manager  
DIN Rail Products

Hello!  
Let me welcome all of you “Low Voltage installation community” to Day by DIN with a question. Did you realize that - for the first time ever - our job has become part of the global political agenda? For the ones who already work since few years like me, could you imagine - when you started your career - that what we do would become common into politics, economics, newspapers and even popular culture? Just figure it out and think: world is definitively changing, and we are a big part of the change! E-mobility is changing the way we travel in a way we can only try to imagine now. Wind and solar power, and energy efficiency are leading world

population to a more sustainable way of living. Building automation and service continuity solutions are dramatically improving the way we live and we work. Electricity business is writing a new page of history books, ABB is a big part of the story and Day by DIN is our way to tell you! So enjoy this edition's articles on wind power, service continuity, lightning protection, building automation solutions, miniature circuit breakers applications; check out our new products, documents and apps for your business; finally, most important, contribute to our growth by sending us your thoughts and questions to [mail.daybydin@abb.com](mailto:mail.daybydin@abb.com).

Enjoy reading!

## Is Day by DIN interesting for you and you want it free of charge?

Make your subscription filling the form you find at the following link: <http://goo.gl/XXeMg> or capturing the QR Code beside with your smartphone. You'll receive your personal printed copy of this issue and all the new ones coming in the future.







**24** **Goodbye to single electricity pricing**  
Greater fairness between consumers:  
pay electricity based on when it is used



**58** **Building automation in the bank**  
For the extremely original “orange bank”, adopting  
the most innovative building automation solutions

## News and facts

- 6** **Jump in the box**  
Fresh news from ABB for your installation!
- 17** **In the news**  
Literature on our latest products
- 22** **Top nine**  
Market classification

## The expert answers

- 28** **Doktor Wise**  
The expert answers

## Curiosity

- 56** **S200 Miniature circuit breakers...over the top!**  
The S 200 series MCBs are suitable for  
installation at high altitudes

## Case History

- 36** **Technological restyling for the Julius Caesar  
room of the Campidoglio in Rome**

## Report

- 30** **Different plugs for different folks**  
With agreement lacking among major nations  
on adopting a single standard, various plug and  
socket models for residential use proliferate.  
Here, we look at some of the most common  
European standards.
- 58** **Building automation in the bank**  
For the extremely original “orange bank”,  
adopting the most innovative building automation  
solutions for controlling power supplies and the  
automation system was a natural step.
- 68** **Modular power distribution solution  
for data centres**
- 76** **Global lightning protection in France**  
Offering services as a way to differentiate
- 85** **From electrician to marketer! - The five “W”s**

## DINgreen

- 84** **New green packaging for the DS201-DS202C  
RCBOs. Compact, ecological and convenient:  
protects the environment as well as the  
product!...**

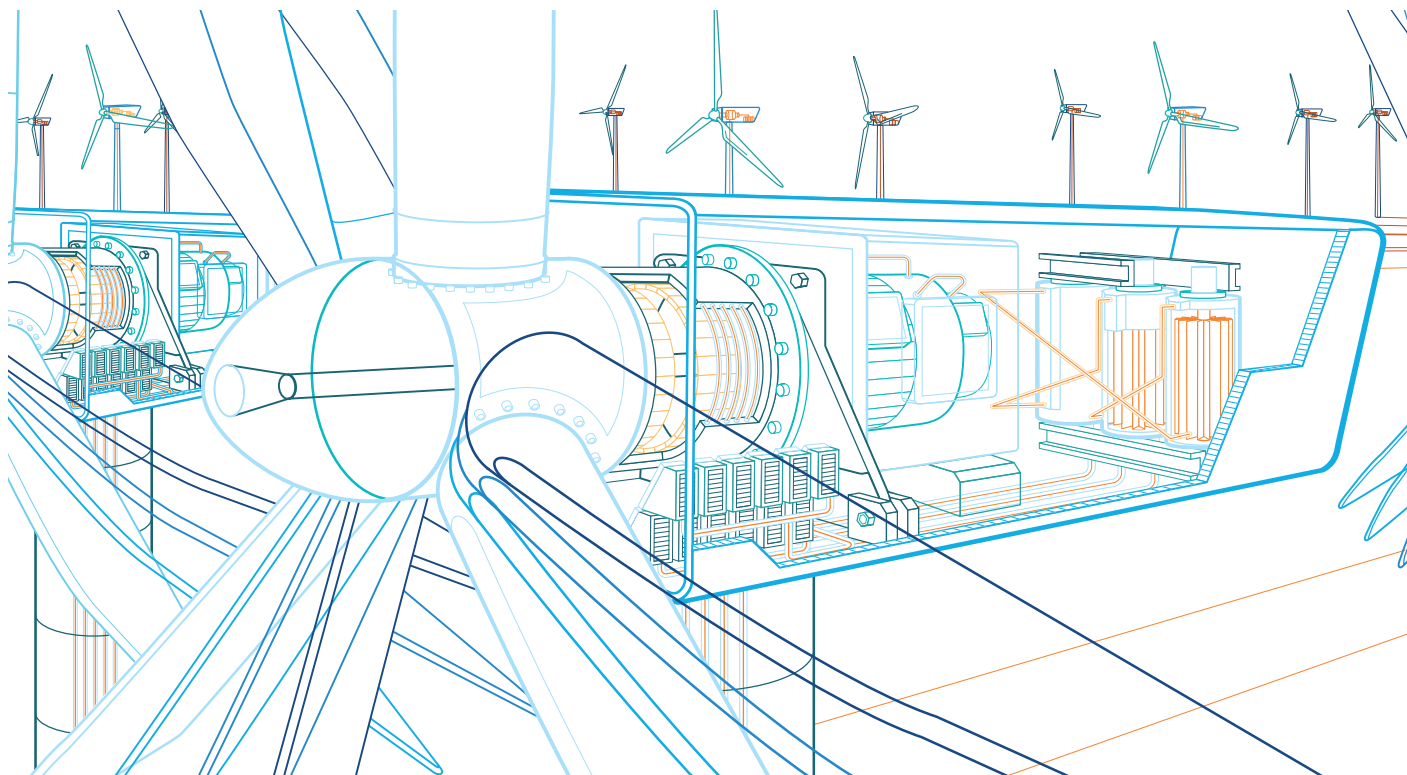

# 62

## Wind and windings

Emission-free electrical energy  
with ABB miniature circuit breakers

## Technical

### 24 Goodbye to single electricity pricing

Greater fairness between consumers:  
pay electricity based on when it is used

### 42 Simplify design

With the complete AF contactor and motor protection range, panel builders, OEM's and many more can enjoy having their design and assembly process simplified. Reduced width and energy consumption helps save space, time and ultimately money.

### 44 Comparison of tripping characteristics for miniature circuit-breakers

The requirements for "Protection for safety – Protection against overcurrent" are specified in IEC 60364-4-43.

### 52 Bring together selectivity, back-up and service continuity

One device for selectivity & back-up protection

### 62 Wind and windings. Emission-free electrical energy with ABB miniature circuit breakers.

ABB offers a broad assortment of low voltage products for wind turbines, to meet the increasing demand of renewable energies and to achieve the paramount goal of reducing CO<sub>2</sub> production

### 72 Lightning a natural phenomenon!

Lightning strikes - Description of this powerful phenomenon to understand better the power of nature.

### 78 ABB Smart Lab

ABB is proud to present the new Smart Lab, dedicated to study and simulation of Smart Grid components and systems.

### 80 New design for an overcurrent tripping unit independent from the ambient temperature

## Time to relax

### 86 Connect the boxes

# Jump in the box

ABB's newest products and solutions from Enclosures and DIN Rail Products world! In this issue new enclosures and accessories, CMS, KNX products and more.

Intelligent Building Control

## ABB i-bus<sup>®</sup> KNX Room Master 4.1

Bridging conventional electrical installation and KNX world

Room Master RM/S 4.1 is ABB's latest addition to the range of Room Master solutions for apartments, hotel rooms, offices, etc. Room Master devices offer electrical connections and control features required in defined functional areas and substantially facilitate planning, installation and putting into operation new electrical installations. Conventional electrical installations and network-based KNX intelligent building installations are moving closer together. Room Master 4.1 features 8 binary inputs and 8 switching outputs.

**Order Code:** 2CDG110170R0011



### Benefits

- Preconfigured and tested ETS projects for different applications: e.g. for hotel rooms, apartments
- Internal connection of inputs and outputs, works without group addresses
- Extended functionality via optional integration in KNX networks with ETS software

Intelligent Building Control

# ABB i-bus<sup>®</sup> KNX Input / Output Actuators

The standard solution for many projects



ABB's new range of Input / Output Actuators offers a compact solution for standard room applications. For this purpose the devices feature binary inputs and switching outputs which can be linked via internal connections independent from bus communication for a quick commissioning with ETS software. For an extended functionality the actuators are capable of being integrated in KNX networks.

Two devices are available:

- IO/S 4.6.1.1: 4 binary inputs, 4 switching outputs
- IO/S 8.6.1.1: 8 binary inputs, 8 switching outputs

**Order Code:** 2CDG110168R0011

**Order Code:** 2CDG110169R0011

## + Benefits

- Cost-efficient and compact devices
- Internal connection of inputs and outputs, works without group addresses
- Extended functionality via optional integration in KNX networks with ETS software

Intelligent Building Control

# ABB i-bus<sup>®</sup> KNX DALI Light Controller

Decentralized DALI lighting control

With the new DALI Light Controller DLR/A 4.8.1.1 ABB expands its offer in the field of DALI lighting control and decentralized installation. The surface mounting device (type of protection: IP54 in accordance with EN 60 529) addresses up to 64 DALI members which can be assigned to 8 groups of luminaires. In combination with light sensors the device features 4 fold constant lighting control for saving energy. Lighting scenarios can support the room utilization demands with up to 14 scenes. A staircase lighting function facilitates time-dependent lighting control. With the integrated master-slave operation, any lighting groups can additionally optimize the energy consumption.

**Order Code:** 2CDG110172R0011



## + Benefits

- Connection of up to 64 DALI members
- Control of 8 groups of luminaires, up to 4 closed-loop control circuits
- Up to 14 lighting scenes configurable
- Extension to ABB's Room Controller concept
- Flexible and cost efficient solution, esp. for the refurbishment of buildings

Enclosure

# TwinLine

## The new system of wall-mounting and floor-standing cabinets

The TwinLine system is a fully comprehensive product range, available in both protection classes and three cabinet depths, and all with the high IP55 degree of protection. With the TwinLine system, STRIEBEL & JOHN has set another milestone in the field of modern power distribution. TwinLine has been tested according to IEC 61439 and DIN EN 61439 Parts 1 and 2.

**Flyer:** 2CPC000169L0201



### Benefits

- Innovative flange technology
- Significantly more usable area for cable entry
- All flanges are compatible with all flange openings and knockouts within the entire TwinLine system
- Uniform fastening for all internal configurations
- Perfect internal configuration with CombiLine-M modules
- Optimal accessibility and ease of installation thanks to 180-degree door opening angle
- All cabinets can easily be combined in series both vertically and horizontally
- Time-saving plinth assembly and secure transport
- Simplified accessories concept for reduced inventory levels





Can we make energy count?

Definitely.



In any industrial situation, time is money. Recent trends in the low voltage panel board market point towards bigger industrial complexes. The new MNS panel boards, with the AF contactor range implemented has had its energy losses reduced by as much as 28% while increasing functionality and service life. To stay efficient, you need Control. Connect to Control. [www.abb.com/connecttocontrol](http://www.abb.com/connecttocontrol)

Enclosure

# N/PE Quickterminal

For consumer units, compact distribution boards,  
meter cabinets, wall-mounting and floor-standing cabinets

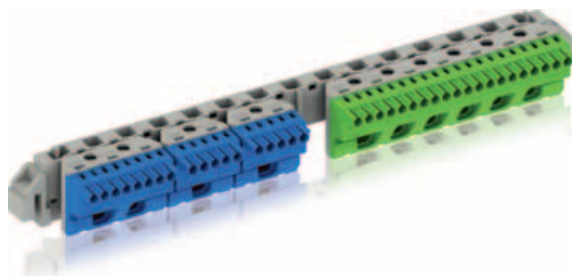

The new N/PE Quick-terminals from STRIEBEL & JOHN are looking toward the future. Conforming to the current standard DIN VDE 0100 Part 410 and extremely flexible in terms of terminal size and expandability, these N/PE Quickterminals are unmatched for safe, efficient and futureoriented conductor connections. The new technology is suitable for the consumer units from the UK500 and A300 series, for all compact distribution boards, as well as for all meter cabinets, wall-mounting cabinets and floor-standing cabinets.

**Technical Brochure:** 2CPC000149L0201



## Benefits

- Conformity with standard DIN VDE 0100 Part 410 (Protective measures and protection against electric shock)
- Flexible terminal system for different N circuits: Screw connectors: 2.5 to 25 mm<sup>2</sup>, spring terminals: 1.5 to 4 mm<sup>2</sup>
- Optimal for use with multiple residual current devices (RCDs)
- Individual Quick-terminals can be combined on the same quick carrier
- The Quick-terminals can be expanded easily using connecting bridges
- Terminal blocks can be identified with certainty (clear colour coding: N = blue, PE = yellow-green)
- Terminals are easy to label using pre-printed, self-adhesive number strips in accordance with DIN VDE 0603 Part 1
- Wide range of applications: can be used in the UK500 and A300 consumer unit series, in all compact distribution boards, and with all meter cabinets, wall-mounting cabinets and floor-standing cabinets
- The new terminal system replaces the N/PE Quick-busbars that were previously in use



## SMISLINE TP. Touch proof system. Power and Safety.

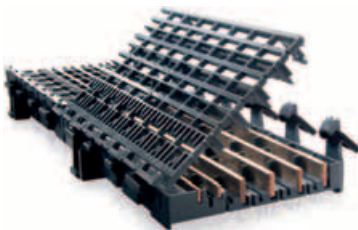

Absolutely safe without protective equipment: SMISLINE TP ensures that load-free devices and components can be snapped on and off under voltage without the need for additional personal protective equipment to guard against electrical hazards. That opens up completely new prospects for you when it comes to installation, operation and flexibility. [www.abb.com/lowvoltage](http://www.abb.com/lowvoltage)

Enclosure

# New CombiLine-M Modules

Extension of today's system

CombiLine-M Modules is a Modular distribution panel system up to 850 A. Due to the continuous product development process new Modules were created to extend the range to suite every application.

Main Catalogue: 2CPC000186C0201



## Benefits

- Extension of existing system
- Modules for Tmax XT 1-4 series
- Module for S750
- WR-frame with horizontal cross members for panel separation
- EDF-frame horizontal cross member for the panel separation to the top or/and bottom
- Busbars for Floorstanding cabinets with panelwidth 6
- Busbars for TwinLine cabinet to cabinet connection
- Busbar system 60 mm, vertical
- Sheet steel partitions for TwinLine

Enclosure

# UK500 assembly without tools

Improvement of UK500 leading to tool-free assembly



## Benefits

- Quick and easy hollow wall mounting
- Comfortable cable entry
- Extensive easiness of assembly
- Convenient snap-in technology
- Screw less cabling
- Rapid final assembly

The improvement of the UK500 lead to an installation which is uncompromisingly simple, quick and well thought-out. With a simple push-and-stay technology and an all-round ease of installation the time of assembly is vanishing low.

Main Catalogue: 2CPC000186C0201



Measurement

# CMS – Current Measurement System

A unique system for branch monitoring

CMS is a multichannel branch monitoring system, which is able to measure both AC and DC currents in True RMS up to 160A. Installation and integration in new and existing power distribution units (PDUs) has never been easier. Various sensor types allow the mounting in every installation environment. Special attention was paid to create an intuitive concept for operations when the menu navigation for the CMS was designed. Complex user training is not necessary, neither for commissioning nor for the day by day operation. The measurement data can be remotely queried by a RS 485 interface (Modbus RTU).

**Brochure:** 2CCC481002B0201

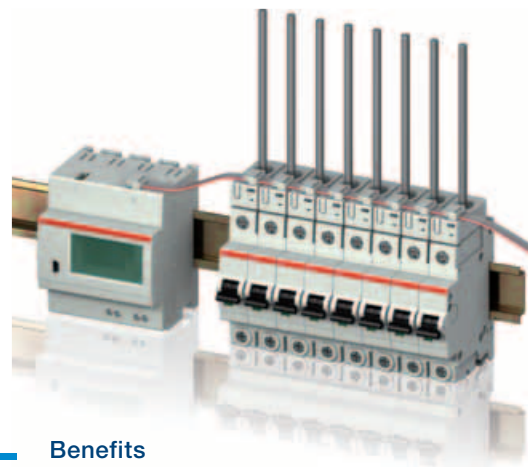

## Benefits

- Minimal space requirements - only 18mm / 25mm wide units
- Quick and easy installation & commissioning
- AC and DC measurement for universal use
- Huge measurement range up to 160A
- User friendly system due to intuitive operation concept
- Contactless measurement for high reliability

Surge protection

# OVR PV UL

Photovoltaic surge protective device listed according to UL Standards



Underwriters Laboratories UL listed OVR PV surge protective devices (SPDs) for photovoltaics according to UL 1449. Furthermore OVR PV SPDs are UL listed according to UL 1449 3rd edition. The UL listing of OVR PV U enables installers and OEMs who need SPD with UL approval to take profit of the specific OVR PV performances into their photovoltaic installations. OVR PV U range is an ideal solution for worldwide inverters and combiner boxes Manufacturers offering their solution in North American markets.

**Catalogue:** 1TXH000168C0202



## Benefits

- Surge protective devices according to UL 1449 3<sup>rd</sup> edition
- Dedicated PV thermal disconnection for safety
- Nominal discharge current (In) from 5 to 10kA (Imax from 15 to 40kA)
- High dc maximum operating voltage from 600 to 1000Vdc

Surge protection

# Autoprotected surge protection devices

## OVR Plus range

Thanks to its continuous innovation on surge protection, ABB improves constantly its offer by launching on the market new type of Surge Protection Devices (SPDs). The modular fully coordinated backup protection SPD of the OVR PLUS family combine a Type 2 SPD and a miniature circuit breaker (MCB) to protect your electric equipment. It widens with the OVR PLUS N1 20kA, completing the existing OVR PLUS N1 and N3 range.

**Brochure:** 1TXH000045B0203



### Benefits

- Surge protective devices according to IEC 61643-11
- Included MCB backup protection
- Complete offer for Residential and commercial in N1 and N3 configuration
- Type 2 with maximum discharge current (Imax) in 20 and 40kA

Socket outlets

# New standards for modular socket outlets

## Connect everywhere



Modular sockets allow the connection of devices, tools or electrical and electronic non modular equipment in civil and industrial electrical switchboards.

ABB has a very wide range of modular sockets, which includes more than 30 models conforming to 5 national standards – Italian, French, German, British, Swiss – suitable for use in around 180 countries.

The modular sockets have local quality approvals, attesting their conformity with applicable regulations.

**Brochure:** 2CSC446011B0201



- Large cage terminals to ease security wiring
- Safety shutters: socket holes protected
- Screws: Pozidriv® screws, tightening torque 1.2 N
- Indicator light: voltage presence indication
- Integrated fuse: 5x20mm 6.3A aM fuse protecting phase

## Enclosures

# SRX, AMX and ISX

## Stainless steel enclosures for automation

The Automation enclosure family is enhanced with the new AISI 304 stainless steel structures, to guarantee to all sectors requiring it, high standards in terms of hygiene and corrosion resistance. Performance complies with market requirements and guarantees high degrees of protection (IP66, NEMA 4X) and strength (IK10 for metal structures with blind door): these characteristics allow installation in most industrial environments in the reference sectors, such as the food industry in its various applications, the chemical sector, the pharmaceutical and hospital sector. The stainless steel is suitable for the most different situations: temperature changes are no obstacle, nor is resistance to various types of external actions (heat sources and naked flames, UV rays, electromagnetic waves and other types of mechanical stresses).

The ABB stainless steel range includes:

- SRX enclosures (with blind door or glass door)
- AMX monobloc cabinets (with blind door or glass door)
- ISX modular cabinets (with blind door or glass door)

**Technical catalogue:** 1STC804021D0201



### Benefits

- **Outdoor:** thanks to the high degree of protection (IP66, NEMA 4X) and to the special mechanical properties of stainless steel, the new range of enclosures can be installed outdoors.
- **Hygiene:** Easy cleaning of this material and the Scotch-Brite finishing makes it suitable for use in environments requiring high levels of hygiene.
- **Wide range of available sizes and accessories:** Accessories for AMX monobloc cabinets, ISX modular cabinets and SRX enclosures include both AISI 304 stainless steel components and standard mountable code items also found in the General Catalogue Enclosures for Automation (1STC804013D0203)
- **High mechanical strength:** IK10 for metal structures with blind door, Vibrations tests according to IEC 60068-2-57, Seismic tests according to IEE Std 693.
- **The safety provided by a certified product:** Busbars system tested by LOVAG-ACAE up to 1600A (Icw 65kA) complies with IEC 61439-1-2
- **UL Listed (UL508):** All products in the stainless steel range are UL approved to also meet the requirements of markets where this mark is compulsory.



New AISI 304 stainless steel enclosures for Automation.  
The strength of stainless steel, the power of quality.



Conceived to grant high standards in terms of protection and sturdiness and in order to offer a very high level of hygiene, the new enclosures for Automation made in AISI 304 stainless steel are intended for all the sectors where effectiveness and efficiency in any environment and climate condition are required such as the food industry, the chemical, the pharmaceutical and the hospital sectors.

Made to be resistant to the corrosion and obviously fully integrated with the various control, command and distribution ABB devices, the stainless steel enclosures are UL approved and they enlarge and complete the ABB offer, by establishing a new level in the designing of enclosures for Automation, ever more functional, resistant and performing.

[www.abb.com](http://www.abb.com)

Power and productivity  
for a better world™





# In the news

Distribution and measurement, disconnection and protection: lots of new documents by ABB for those operating in the electrical business, helping them in their work.

The documents and the software can be downloaded from <http://www.abb.com/abblibrary/DownloadCenter/>

Enclosures

## TwinLine

The new system of wall-mounting and floor-standing cabinets



Are you looking for a modern, user-optimised and future-proof cabinet for distribution board assembly? Then you will surely find it with TwinLine. The TwinLine system is a fully comprehensive product range, available in both protection classes and three cabinet depths, and all with the high IP55 degree of protection. With the TwinLine system, STRIEBEL & JOHN has set another milestone in the field of modern power distribution. TwinLine has been tested according to IEC 61439 and DIN EN 61439 Parts 1 and 2.

Flyer: 2CPC000169L0201



Software

## EDS PowerCon

Think in terms of functions, not products



Planning an ASSEMBLY in just a few minutes? Without any prior knowledge of STRIEBEL & JOHN products? Not a problem. The exemplary user friendliness of EDS PowerCon. EDS PowerCon supports you at the beginning of the planning process by means of a simple, intelligent input mask: You only have to enter the key data of the distribution, the electrical and mechanical function of the section, and EDS PowerCon takes care of the rest.



Socket outlets

## Modular socket outlet

Connect everywhere



ABB has a very wide range of modular sockets, which includes 38 models conforming to 7 national standards – Italian, French, German, English, Swiss, Australian and Argentine – suitable for use in around 180 countries.

The modular sockets have local quality approvals, attesting their conformity with applicable regulations. In addition to the grey-coloured (RAL 7035) version there are three other colours (red, green and black) which are useful to indicate specific socket uses. Versions with integrated voltage indicator lights and fuse complete the range.

Catalogue: 2CSC446011B0201

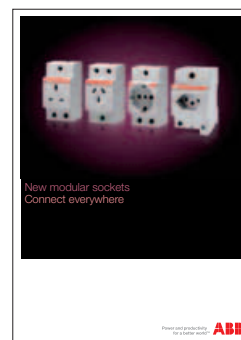

Software

## OPR Designer

Get your lightning study in few clicks



ABB is happy to provide you with a complete new software in the field of lightning protection. With a very simple approach you can create your technical study in one click ! You can either draw, import file (AutoCAD, pictures...) and from that point get a complete bill of material (air terminals, down conductors, fixing accessories and earthing system), the positioning of the lightning protection system on the structure. The solution is given in a complete pdf file that includes:

- protected areas
- lightning air terminals positioning
- complete bill of material
- detailed bill of material per building
- catalogue pages for each component
- test certificates
- This software is so far available in English, French, Spanish, Russian and Lithuanian version.



Protection

## S200 / S200M: The next MCB generation

Uncompromising safety and comfort

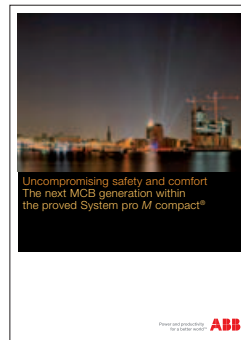

A range designed to ensure efficiency and protection: Our MCBs are advanced for more than 120 years in the history and mindset of the inventor Hugo Stotz. Today we offer feasible MCB solutions for all kind of applications, which are developed in close touch to market requirements from various branches. Numerous patents have been made during this time and ensure our market position as the "original" and innovation leader. This brochure is talking about facts and benefits, the details which makes the differences as well as about worldwide approvals and standards. Another topic is quality and sustainability, describing all the tests we're doing and further sources of information.

**Brochure:** 2CDC002026B0204



Protection

## Surge and lightning protection ABB solutions

The complete catalogue for overvoltage protection



The general catalogue on ABB low voltage surge and lightning protection. For the lightning protection of building with the OPR external protection and the surge and overvoltage protection from the transformer side up to the main distribution board and the sub-distribution board. The surge and lightning protection solution ABB offers.

**General catalogue:** 1TXH000083C0202



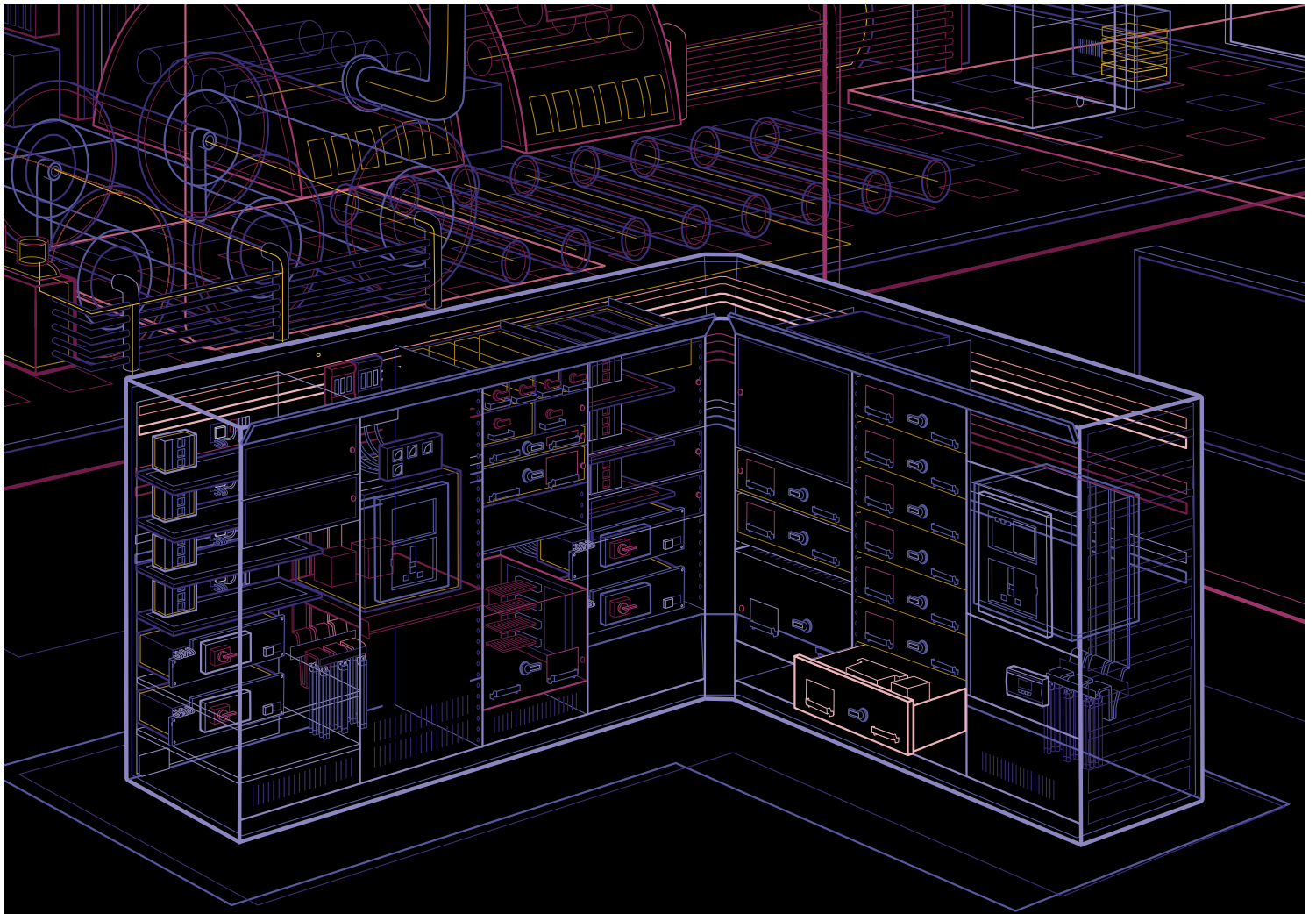

Simplify design. Connect to Control.



A reduction of the contactor's coil energy consumption by up to 80%. That means panels can be built smaller and transformers more compact. The new ABB contactor and motor protection range gives 'user friendliness' new meaning. With all the features of the AF technology along with access to drawings and coordination tables online, you can be sure to have your design and assembly process simplified. Connect to Control to see more. [www.abb.com/connecttocontrol](http://www.abb.com/connecttocontrol)

Protection

## Wind turbine surge protection guide

Earthing, lightning and overvoltage protection

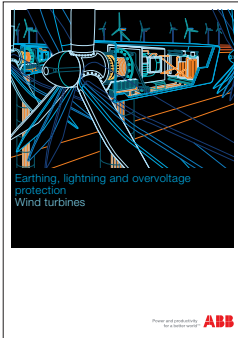

Based on the experience we have gained over the last decades, ABB provides state-of-the-art low-voltage surge protection devices (SPDs), medium and high-voltage surge arresters (SAs) and earthing and lightning protection (ELP) materials to protect against the impact of direct lightning and transient overvoltages caused by the secondary effects of lightning. Thanks to this wide product-range, ABB offers complete solutions for protection of wind-power installations.

Leaflet: 1TXH000215B0201



Tablet Apps

## Brand new app about ABB solar solutions

A new level of efficiency and availability



Explore how ABB is capturing the power of the Sun through our wide range of products, systems, services and solutions for utility scale solar photovoltaic (PV) power plants. Learn about the benefits of our comprehensive solar product portfolio, including low voltage components, solar inverters, solar tracking, grid connection and remote plant monitoring solutions by browsing the product landscape. ABB has a long and successful track record as a turnkey PV solar power plant supplier. Discover how we deliver a solar power plant from land clearance through installation and grid connection in the turnkey solution landscape; or browse through some of our reference projects around the world in the references landscape.





Smartphone Apps

## T Wizard



T Wizard is the app of ABB Wizard suite which allows you to easily select the transformer you need in few simple steps, wherever you are, now available also for Android devices!

T Wizard helps you to select codes of ABB TI, TM and TS series for all applications: bell transformers; control, safety and isolating transformers; insulating transformers for medical locations. In few steps T Wizard provides you the right code, listing also technical characteristics and documentation links.

Smartphone Apps

## CT Wizard



CT Wizard is the app of ABB Wizard suite which allows you to easily select the current transformer you need in few simple steps, wherever you are, now available also for Android devices!

CT Wizard helps you to select codes of ABB CT series for all industrial, residential and commercial buildings applications. In few steps CT Wizard provides you the right code, listing also technical characteristics and documentation links.

Smartphone Apps

## S200 Wizard



S 200 Wizard is the app of ABB Wizard suite which allows you to easily select the MCB you need in few simple steps, wherever you are, now available also for Android devices!

S 200 Wizard helps you to select codes of ABB S 200 series for all industrial, residential and commercial buildings applications.

In few steps S 200 Wizard provides you the right code, listing also technical characteristics and documentation links.

# Top nine

The ideal solutions to protect the photovoltaic systems, ensure the safety of the installations and maximise the yield of the energy produced. Find further technical information on ABB System pro *M* compact catalogue.

## ISL-A 600

Insulation monitoring device



In the photovoltaic networks the continuous monitoring of the level of insulation is indispensable in order to identify failures and restore the optimal operation of the system. ISL-A 600 is realised in order to execute this task for networks in direct current up to 600 V. By installing ISL-A 600 on the DC side of a photovoltaic inverter, it is possible to optimise the maintenance and the costs connected to system down times.

## EQ Meters

Energy measurement and system performance monitoring



The measurement of the energy produced by a photovoltaic system is not only important to know the consequent earnings, but to ensure system productivity is under control every day. Thanks to features like MID approval, four quadrants measurement and remote communication, EQ meters from ABB new range can fulfill requirements of every size of installation, from small residential roof-top system to large solar farms.

## S802PV-M-H

The switch disconnector 1000V DC within 54 mm



In times of increased pressure to save costs on photovoltaic systems, ABB offers now S802PV-M-H, a brand new 2-pole disconnecter for voltages up to 1000V DC and for rated currents up to 100A. S802PV-M-H is specifically designed as mains string box disconnecter and finds ideal application in combination with E 90 PV fuseholders and E 9F PV fuses. Highlights of S802PV-M-H are the fast, no jumpers installation, and the enhanced system productivity and cost efficiency thanks to a power loss 50% smaller than 4-pole design.

## S800 PV-S

High performance MCB for Photovoltaic plants



S800 PV-S MCB can be used in networks up to 1200 V DC (four poles versions). Fault indication is provided by the handle, featuring a trip central position. All the S800 PV-S MCB can be feeded indifferently from above or below without any restrictions on the polarity.

## S800 PV-M

Switch disconnectors



S800 PV-M are suitable for the switch disconnection of the strings of photovoltaic systems up to 1200 V DC. S802PV-M25A 650 V DC has been added to the series for small/medium size systems and inverters below 6 kWp in which the maximum input voltage is less than 650 V DC. All the series can be feeded indifferently from above or below without any restrictions on the polarity.

## E 90 PV, E 9F PV

Switch disconnectors and fuses



Designed for the protection and the disconnection of PV circuits up to 1.000 V DC, E 90 PV are ideal for the protection of the strings and the backup of OVR PV SPD. E 90 PV find their best features in combination with E 9F PV fuses. Thanks to UL listing and IEC 60947-3 conformity, E 90 PV are the ideal solution both for photovoltaic systems and as components of photovoltaic inverters in every Country.

## OVR PV

Surge protective devices



OVR PV surge protective devices, designed specifically for the photovoltaic systems and compatible with all the installations types, manage the end of life in total safety and are self-protected up to a short-circuit current of 100 A DC. The TS versions allow to monitor the state of the protection and the pluggable cartridges make maintenance even easier.

## F 200 B

B type residual current circuit breaker



F 200 B RCCB provides protection against indirect contacts by automatic interruption of the power supply. They are also sensitive to the ground fault currents with modest undulation, assimilable to continuous type ground fault currents. These currents are the fingerprint of a failure on AC side of a solar inverter without insulation transformer; therefore it is highly recommended to install a B type RCD on the AC side of a transformerless solar inverter.

## DDA 200 B

B type RCD blocks



DDA 200 B, B type RCD blocks, in combination with S200 MCB ensure the protection of the people and the installations against the risk of fires, short circuits and surges. As B type residual current circuit breakers, DDA 200 B find their typical application the AC side of a transformerless solar inverter.

# Goodbye to single electricity pricing

Greater fairness between consumers:  
pay electricity based on when it is used

Aron Svedin: *Product Marketing Manager - DIN Rail Products*

It is becoming more and more common for governments to introduce regulations for multiple tariffs measuring, that is different pricing for energy depending on the time of the day or the day of the week it is used, it could even depend on seasons or on special holiday times.

## **Advantages and motivations for different pricing**

With multi tariff system, users can measure and control their own consumption to have the advantage of being able to consume electricity during the hours when it costs less. The result is a lower electricity bill at the end of the month, without using less electricity.

The different multi tariff prices offer opportunities to save money as long as the users concentrate their use of electricity in the cheapest times which, in a year, could cut the cost significantly. The savings will be greater the more usage is shifted into these cheaper time bands. In order to take advantage of the multi tariff model it will therefore be essential to know one's usage profile and concentrate more energy consumption in the cheaper times by changing usage habits for various power-hungry appliances (e.g. washing machine, dishwasher, water heaters, electric oven/hob, irons etc.).

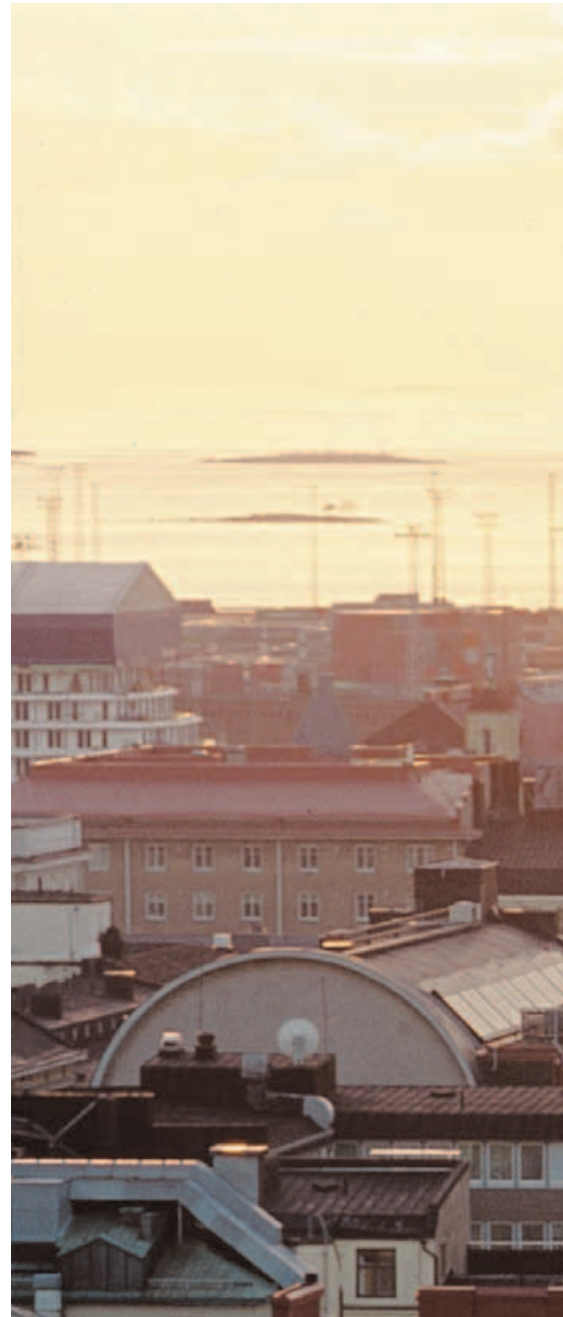





The technical/economic motivation for governments and utilities to differentiate the cost of electricity on the basis of multi tariffs is due to the grid load curve. It is necessary to construct power stations and grid infrastructure in order to meet peak demand, while much capacity will go unused at other times (off-peak). This requires greater investments in systems that are utilized very poorly and this extra cost is in the end paid by the end customer. Flattening the load curve by shifting consumption from peak to off-peak times allows better use of the resources and systems already available.

All this means that those who, at the moment, use electricity in off-peak hours are paying more than needed due to the inefficiencies explained above, caused by those who consume electricity at peak-time, which is not fair.

These unofficial subsidies are, in a certain sense, eliminated with multi tariff system, creating a fairer system for consumers: each consumer will pay based on when they actually use the electricity. Greater awareness in using our precious resources is also encouraged by this system, with positive effects on energy savings, the protection of the environment and more sustainable development, benefiting everyone.

Dual tariff rate band

Time band	Working days	Weekends and holidays
from 0.00 to 8.00		
from 8.00 to 19.00		
from 19.00 to 24.00		



Bands F2 and F3, when electricity costs less.  
Band F1, when electricity costs more.

Table 1

**When, during what time period, should electricity use be concentrated?**

The multi tariff system is based on the idea that the electricity price vary according to the demand, which is depending on the time of day: when there is less demand (the evening and first thing in the morning, at night and during weekends and holidays) the price is lower; during work hours, in the middle of the day, the price is higher.

An example on how a dual tariff system could look like (table 1). The electricity:

- Costs less between 19.00 and 08.00 on weekdays and all day on Saturdays, Sundays and holidays; these periods will be indicated on the electricity bill as bands "F2 and F3"
- Costs more between 08.00 and 19.00 on working days; this will be indicated on the bill as band "F1".

By measuring electricity consumption divided for example by time periods with different prices, awareness will become an essential requirement for all custom-

ers. This awareness gives the customer knowledge on how to influence the electricity bill by adapting more cost effective habits of using our precious energy.

**Measurement, the first step towards awareness and real energy efficiency**

**EQ meters are perfect for customer who wants to be aware**

EQ meters A series are meters for direct connection up to 80 A with accuracy class 1 and are approved and verified in accordance with the MID directive for metering for revenue purposes, as indicated on the product and its packaging. This means that the EQ meters fulfill the standard requirements and the customer will never have any regrets buying EQ meters.

The EQ meters can handle up to 4 different tariffs in where the active energy used during a specific tariff is saved into its own energy register. A main energy register is meantime saving the total active



EQ meters is the ideal solution for metering of energy consumption over multiple tariffs.

**Did you know that there are three kinds of energy?**

Energy is closely linked to power and there are active power, reactive power and apparent power (Read more about the difference between power and energy later in this edition). Therefore it also exist active energy, reactive energy and apparent energy. In the majority of the countries around the world the customer is only charged for the use of active energy, which is the energy that our loads use to operate. Due to that we use alternate current (AC) in our grids the phase angle could be shifted by some loads that are found in our homes. But the major part of these kinds of loads are found in industry applications. This shift in phase creates reactive energy which loads cannot utilize any work with. But still it runs in our cables and in the electricity grid and occupies space for active energy (the useful energy). A lot of reactive energy makes the electricity grid very ineffective. Therefore it is common in many countries that factories that let to much reactive energy back out on the electricity grid have to pay penalties. Apparent energy is not usually considered except in some countries, e.g. South Africa, and is a kind of summation of active and reactive energy.

## Small domestic automation devices in order to use electricity at the cheapest times.

The D Line time switch sends the command to turn on domestic appliances such as washing machines and watering systems when the cheaper electricity band starts.

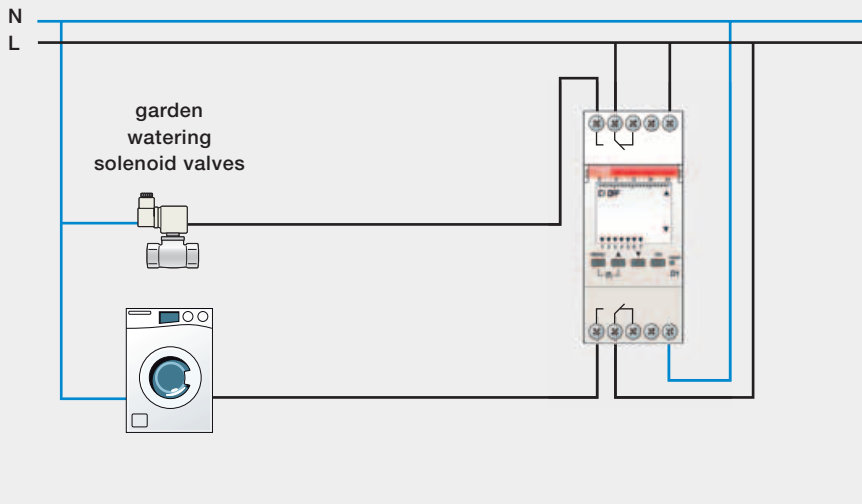

Easy to program, the D Line range of time switches allows domestic loads to be operated according to the different time bands programmed in its memory, thus reducing energy bills.

energy going through the meter. The tariffs are changed either by an external signal, or via communication, that tells the meter that it is time to change to a different tariff, or by the internal clock that is included in some of the versions of EQ meters A series. It is then possible to set a time when a specific tariffs should be active. The meter will then change automatically and save the consumed active energy used in the right tariff register.

With EQ meters A series it also possible to save the present value of the different tariff registers at a specific time, e.g at mid-night the last day of each month. This could be used to see if the habits for using various power-hungry appliances have changed by comparing the different tariffs registers for each month. With this functionality the customer can always find previous month values saved in the meter.

An additional feature with EQ meters A series is the possibility to save demand values which means that the customer can configure the meter to save the energy value with a time stamp when the most and the least energy where used during a day or during a week. If the highest usage is during the high priced tariff period there might be beneficial to investigate if it is possible to move this usage to a lower price tariff to lower the electricity bill. Awareness and knowledge is the key to be able to lower electricity cost.

EQ meters A series are available for both direct connected single phase applications, A41, and for for direct connected three applications, A43. They are suitable for DIN rail mounting and they can be installed in electrical switchboards and distribution switchboards to monitor energy consumption. The wide and complete range allows all possible applications: such as shopping malls, airports, buildings, production processes and systems, and more. The EQ meters can be monitored remotely thanks to option of inbuilt communication protocols, Modbus and M-Bus, and all meters have a pulse output.



**Aron Svedin**  
Product Marketing Manager  
DIN Rail Products

# Doktor Wise

## The expert answers

The reliability of ABB's experience in its responses to every need arising from the work of professionals in the sector. In this section an ABB expert responds to the most frequently asked questions that regard the use of DIN rail and front panel products, to resolve problems and propose the most suitable solutions for every application.

In this edition we clear up the frequently confused concepts of energy and power and try to make a simple estimate of how much they cost us.

Aron Svedin: *Product Marketing Manager - DIN Rail Products*

### When should we talk about power and when about energy?

Energy and power, while strictly connected to each other, have a relative difference which it is important to fully understand.

The power drawn by a load is an intrinsic characteristic of the load itself and the network it is attached to and it is not, therefore, sufficient to determine the energy consumption of the appliance: it represents an index of how much it could consume at a given time.

The energy used by a load is equal to the accumulated power during a time period. That is a summation of the power used by the load at any given time during the whole time period; the longer the load is operational, the higher the energy consumption and, therefore, the electricity bill.

So we should talk about power when describing the characteristics of a load and talk about energy when talking how much the load cost in terms of used energy during a specific time period.

### When should we talk about kW and when about kWh?

kW and kWh are two units of measurement of power and energy, respectively. The significant difference between power and energy is that the latter carries with it the idea of time and the two units of measurement express this difference. With kW (kilowatts) we measure power, in other words the possible consumption of an appliance

at a given time; with kWh (kilowatt hours), on the other hand, we measure the energy consumption of an appliance over the course of one hour.

Supporting what we have already said, if you look at your electricity bill you will see that all consumption is measured in kWh, which is the measurement unit for energy.







High-power appliances in a home such as washing machines, dishwashers, vacuums, and professional hairdryers does not mean a four-figure electricity bill; what explains a large bill is excessive use of them. That is using high-power loads during long time, which generates many kWh.

### How much energy does a 1 kW load consume then?

Let us use a 1 kW electric heater installed at home as an example. This heater does not consume energy when it is switched off, only when it is turned on.

This is to highlight that the heater does not use energy except when running, and the higher its power and longer its operating time is, the more energy it uses; as such, power refers to an indication of consumption, and not consumption in itself.

### Quick reference\*

Appliance	Power [W]	Euros/ half hour	Euros/ hour
Light bulb	100		
Television	400		
Hairdryer	1.200		
Dishwasher	2.000		

\* Electricity costs were calculated assuming an average energy cost of 15 Euro cents/kWh.

How much you spend, in short: Euro cents spent = (Power in kW/4) x minutes operation

Euro cents spent = (Power in W/4,000) x minutes operation



The 1 kW electric heater will consume 1 kWh for each hour of operation, which equals to approximately 15 Euro cents, if we consider an average energy cost of 0.15 Euros/kWh.

Following what we have said, if we connect a power meter to the load in series with an energy meter, the first meter will give a stable and constant reading of 1 kW, while the second meter will give a constantly increasing reading, representing the total energy used, which increases as time passes.

#### **I have a 2,000 watt dishwasher: how much does it cost me?**

The dishwasher is one of the most energy-hungry electrical devices, along with the oven, the vacuum and the washing machine. 2,000 watts of power draw means energy consumption of 2 kWh every hour of operation, which is roughly the time required for a standard wash cycle.

This energy consumption for one wash cycle equals to a cost of approximately 30 Euro cents. Calculating an average of two wash cycles a week, one for white and one for dark clothes, this gives a yearly cost of

**2 x 52 weeks x 30 Euro cents = 31,20 Euros**

That is 31,20 Euros a year in energy cost only for washing the clothes. If instead there are 4 wash cycles a week that gives 62,40 Euros a year in energy cost for washing clothes and then washing detergent and water costs are not included.

## Did you know that?



**A digital multimeter allows the loads in an installation to be managed, avoiding power overloads or undervoltages.**

Aside from the usual function of measuring the main electrical parameters, the DMTME-I-485 digital multimeter is equipped with two relay outputs programmable as alarm outputs. Setting alarm thresholds for the main parameters such as current, voltage and power allows the installation to be kept under control at all times.

The multimeter allows you to set system automation; to prevent malfunctions due to current overloads and undervoltages; to manage maintenance; and to not exceed contracted power consumption, which would result in penalties payable to the electrical company.

Performing the same functions as the LSS1/2 load shedding switch, the DMTME-I-485 has the additional advantage of being installable in both single-phase and three-phase networks.



**An electricity meter lets you measure the total amount of energy that all the loads installed after the meter have consumed.**

EQ meters from ABB include a wide range of electricity meter for most kinds of applications or installations. By installing electricity meters for different groups of loads it is possible to cost allocate energy costs and understand the total

energy usage better. To understand and have knowledge of costs is the essential behind taking decisions which makes the electricity meter the perfect tool to cut your electricity bill and use the energy more effectively. EQ meters have the option of inbuilt Modbus or M-Bus communication which enables easy connection to a monitoring system.



# Different plugs for different folks

With agreement lacking among major nations on adopting a single standard, various plug and socket models for residential use proliferate. Here, we look at some of the most common European standards.

Claudio Amadori: R&D ABB S.p.A. - ABB SACE Division

It is well known that domestic power plugs and sockets are among the devices which have always been most resistant to any attempt at harmonisation. Every country, or almost, has their own system. We therefore talk about Italian, French, British, Danish, Israeli, Australian sockets and so on, and their corresponding plugs. Some countries even have multiple types of plugs and sockets, introduced at different times and still in use. You can find an up-to-date list of the plugs in use in different countries around the world here: <http://www.iec.ch/worldplugs/map.htm>

On a world level, the lack of unification in sockets also corresponds to differing low-voltage electrical distribution systems (e.g. 120 V/60 Hz in North America, 230 V/50 Hz in Europe).

Within Europe at least, this problem does not exist: electrical voltage does not vary from country to country in our continent.

Although this grid homogeneity should simplify the process of standardisation, purely mechanical differences persist which make sockets and plugs incompatible among different countries.

The European Union, despite managing to adopt a single currency, has still not been able to impose a single plug, above all due to the resistance of various countries to abandon their own systems. It follows that there is no European standard for domestic sockets: they are exempt from the Low-Voltage Directive, and do not carry CE markings.

As a result, Europe is full of adaptors, both single and multiple, as well as sockets compatible with different plug types, able to make different types of plugs and sockets live together.

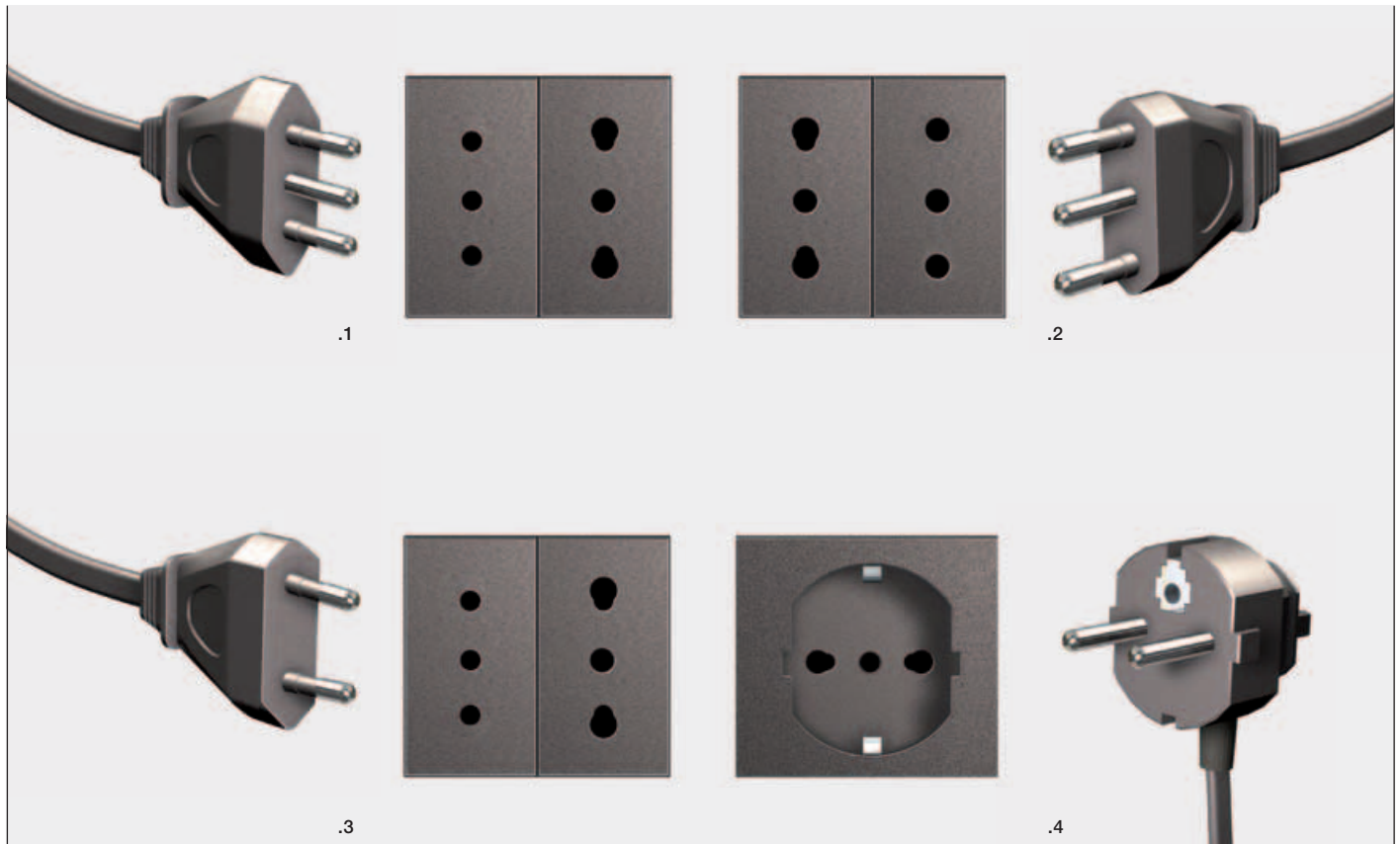

01

.1-.2 - Example of 10 A Italian plug (with 4 mm cylindrical pins spaced 19 mm apart) and 16 A plug (5 mm pins spaced at 26 mm). The dual P17/11 plugs, shown in the photo, are the most common in Italy, as they are able to accept both Italian plugs.

.3 - Europlug, characterised by the lack of earth connection and its two slightly converging cylindrical pins (4 mm diameter, each 19 mm from the centre).

.4 - Example of French-German hybrid Schuko plug, with side contacts to connect with original Schuko sockets and a female contact to accept the pin on French plugs. The P30 socket shown in the photo accepts both Schuko plugs and Italian 10 A plugs with central earth.

In Italy, domestic plugs and sockets dealt with in IEC 23-50 which contains the “standardisation sheets” for local sockets (device types used, in part, also in Uruguay and occasionally in other countries).

Italian sockets include the traditional P11 and P17 (type L sockets according to the IEC classification), able to accept the corresponding plugs with or without earth pin – 10 A (with cylindrical 4 mm pins spaced 19 mm) and 16 A (5 mm pins spaced at 26 mm). Combination P17/11 sockets able to accept both are widespread.

The German Schuko (type F in the IEC classification) plugs have become common, in many European countries, since the corresponding plug was almost universally adopted as standard by electrical appliance manufacturers. In Italy is has been standardised as the P30 socket able to accept both Schuko plugs and the Italian 10 A plug with centre earth pin (the original German Schuko socket, on the other hand, has no central hole and does not accept Italian earthed plugs).

Some standards recommend the installation of sockets able to accept Schuko plugs in the kitchen and for the washing machine. The objective is to limit the use of adaptors, which are not the most suitable solution for connecting more powerful domestic appliances<sup>1)</sup>.

With the lack of agreement on adoption of a unified socket at the European level, the Schuko has become a de-facto standard across a large part of continental Europe.

The Schuko socket was created in 1926 by the German inventor Albert Büttner, and is characterised by its side earth contacts (at the time a real refinement in terms of electrical safety) and the neck which prevents contact with the pins when inserting the plug.

<sup>1)</sup> A Schuko plug must never be forcedly inserted in an incompatible Italian socket: not only would the larger pins ruin the socket, but there would be no earth connection.



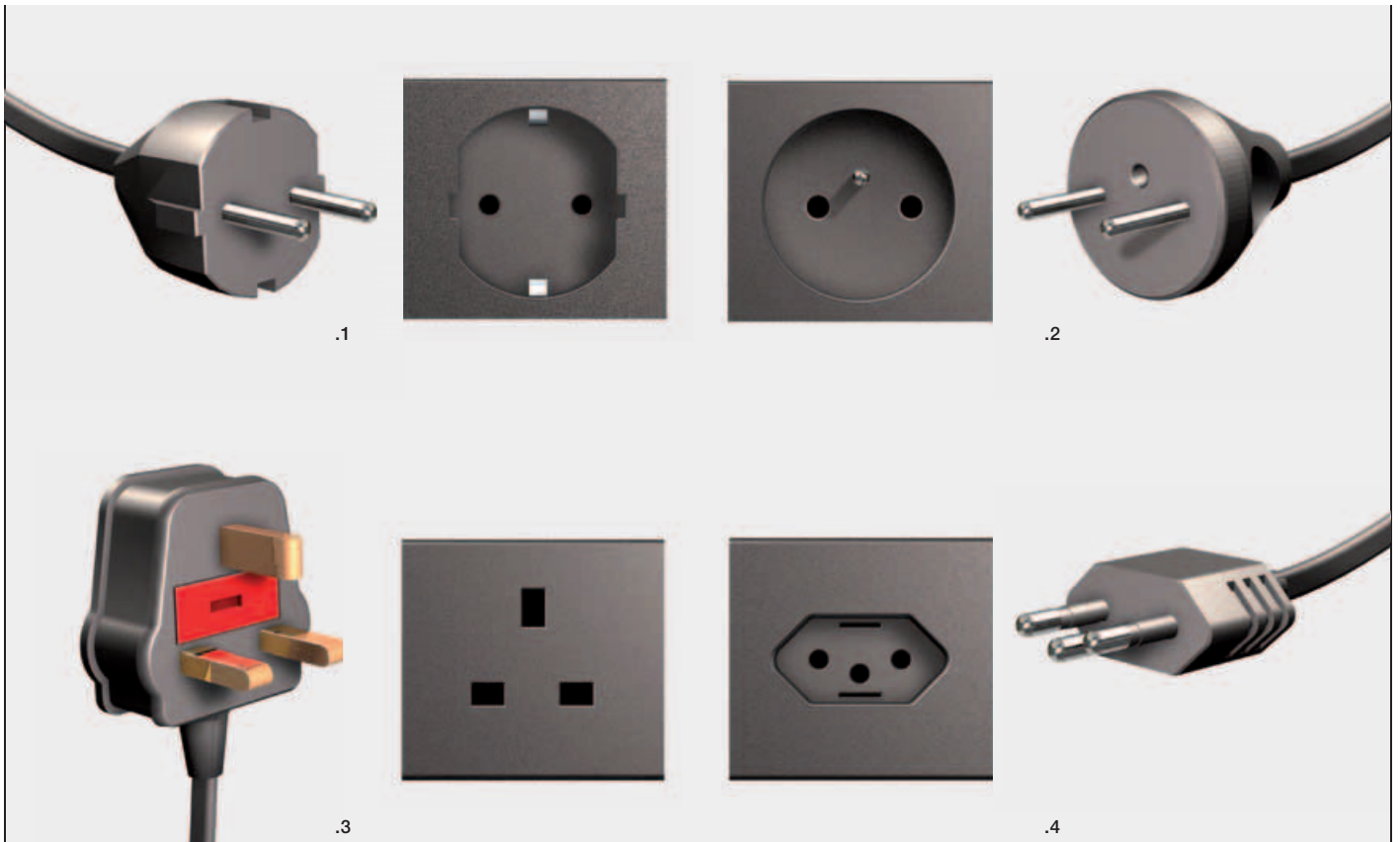

02

The term “Schuko” is, indeed, simply the contraction of the German term Schutzkontakt, meaning “safety contact”. Today, the Schuko is officially adopted as national socket, either on its own or in addition to other formats, in numerous European countries. In reality, the plug used for European appliances is a hybrid Schuko-French plug (S31 according to IEC 23-50), which fits both a German Schuko and a French socket.

The French (type E) plug, very similar to the German Schuko, differs in its earth connection, which is provided by an asymmetrical pin sticking out from the socket which makes it polarised (live and neutral cannot be switched)<sup>2)</sup>.

The other Europe-wide plug is the Europlug (type C), the only one to actually be specified by a European EN standard (EN 50075). This is the common non-earthed plug, with slightly converging pins, and the characteristic elongated hexagon shape of the insulating body. The Europlug is extremely widespread, but is suitable only for powering dual-insulated (class II) appliances: televisions, hi-fis, tools, small domestic appliances etc. This plug’s limited use is due to its restricted current (2.5 A) and lack of earth connection. The two pins, like the Italian plug, are partially insulated towards the body to ensure fingers cannot make contact with live parts when inserting or removing the plug.

- 02 .1 - Example of German Schuko socket and plug. The original Schuko has two side earth contacts. The Schuko system is symmetrical and therefore unpolarised, and suitable for loads up to 16 A.
- .2 - Example of French socket with male earth pin sticking out from the socket itself. The French plug therefore has a female contact corresponding to the male pin in the socket.
- .3 - Example of British Standard socket and plug. The BS plug has three rectangular-section pins arranged in a triangle. The live and neutral pins are parallel, measuring approx.  $4 \times 6 \times 18$  mm with a 9 mm insulated section from the body.
- .4 - Example of IEC 60906-1 socket and plug. The IEC 60906-1 socket is distinguished by its earth contact which is not aligned with the other contacts but offset below them, like on the Swiss plug, but at a different distance.

<sup>2)</sup> Other examples of polarised plug are the Swiss, British, Danish, Australian, Chinese etc.

The Europlug, which is very similar but not identical to the Italian 10 A plug without earth, was specifically designed by the EEC (International Commission on Rules for the Approval of Electrical Equipment) in 1963 in order to fit the majority of existing European sockets. As a consequence, the Europlug can be used with effectively all European plugs, except the British, for which there are specific adaptors.

The IEC (International Electrotechnical Commission), in 1986, after years of work, defined a new system of electrical sockets and plugs for domestic use (250V / 16A), intended to become the universal standard<sup>3)</sup> (type N socket according to IEC classifications).

The new plug is compatible with the Europlug, of which it can be considered an extension, and uses 4.8 mm diameter pins 19 mm from centre. The earth pin, off centre like in the Swiss plug (but with a different distance), ensures the plug can only be inserted one way.

As of today, only two nations have adopted the IEC 60906-1 socket nationally: Brazil (extending the current to 20 A) and South Africa.

<sup>3)</sup> A similar universal plug and socket system, IEC 60906-2, characterised by flat instead of round pins, exists for electrical distribution systems up to 125V and 15A, as found in the United States.

## Did you know that?

### How many power sockets should be installed by the TV?

Although the question might seem simple, the answer is more complicated than you might expect, and we need to make some distinctions.

Fundamentally we can say that the number of sockets to install changes if we consider only the minimum legal requirements or whether we pay closer attention to safety, convenience and the actual use that will be made by the sockets near the TV. Here are two possible answers:

#### 1. Solution Meeting Standards - Example CEI 64/8

The new edition of Italian CEI 64-8 states that 6 power sockets must be installed by the main TV/SAT socket. This minimum solution ensures conformity and an extension of safe outlets, but offers no immediate advantage for the user.

#### 2. Convenience Solution

To meet the actual needs of the end user, we need to perform a more detailed analysis of the use of power sockets located near the television. We can start out by saying that modern TVs are all LCD or LED units coming mainly from abroad and therefore generally fitted with Schuko plugs. They are almost always then connected to another two or three electronic devices: usually a DVD/BluRay player, a satellite or digital-terrestrial decoder and/or a games console. These devices are often fitted with bulky power supply plugs which can block access to surrounding sockets. Taking these aspects into consideration, the minimum requirements no longer seem sufficient to fully meet the actual needs we see every day in a residential environment. The ideal solution is therefore to install six sockets, separated with a blanking plate, to facilitate plugging in power adaptors.

This solution guarantees greater comfort and safety while still meeting legal requirements.

So, what is the best choice?

Minimum standards, or maximum convenience? We know all too well that in many cases it is the price which is the deciding factor, and it is difficult to suggest more expensive solutions, even if they are superior. In any case, a lot depends on the ability to sell one solution over another on the basis of increased functionality, concrete advantages and added value.

In this case, for example, you need to ask whether it is best for the end customer to choose the minimum required when they will then be forced to purchase costly adaptors or use less desirable and safe solutions such as sockets.



## ABB DIN rail socket outlet. Always connected!



Always connected! 180 countries, 38 conforming models, 7 national standards: the ABB DIN rail socket outlets are not only easy to install and perfectly compliant with international regulations, but also represent a safe and effective solution for connecting non-modular devices, tools or electrical and electronic equipment inside switchboards and consumer units. Available in different colours for different applications and requirements, they are completed by a series of functions making them reliable and indispensable in many and various application situations, making maintenance and testing work easy in all four corners of the world. For a world which is always safely connected.

[www.abb.com/abblibrary/DownloadCenter/](http://www.abb.com/abblibrary/DownloadCenter/) - 2CSC446011B0201





# Technological restyling for the Julius Caesar room of the Campidoglio in Rome

Ninety years from its last renovation, the Julius Caesar room, where the Rome City Council meets, has undergone a radical architectural restoration and technological updating. Now the actuators and automatic devices are managed by a centralised system, easily accessible via touchscreen, with clear improvements in terms of energy savings, safety and intervention speed.

Thomas Rodenbusch-Mohr: *Product Marketing - KNX Intelligent Building Control*

Legend has it that the name Campidoglio comes from when a skull (caput) belonging to an Etruscan warrior was found when digging the foundations of the temple of Jupiter. The name of the warrior was Tulus or Olus, leading to caput Toli, Capi-tolium and then Campidoglio. In fact, the Campidoglio has been a fundamental public building for the city of Rome for more than 2000 years.

## Control of automatic systems via touch panel

The Sala dell'Assemblea Capitolina di Roma Capitale, Rome City Council's Hall, known as the Julius Caesar room due to the presence of a statue of the emperor dating to the first century BC, hosts the posts of the President and Mayor, as well as the councillors. There are 84 new high-backed chairs, for the majority and the opposition, equipped with integrated touchscreens for electronic voting accessed via magnetic cards, like the Italian Lower House of Parliament. Last but not least, there are 400 places reserved for the public, who form an overall numerically very important capacity.

Nearly 90 years from the last restoration, the Julius Caesar room has under-

gone a radical work in restoration, either about architecture and about technology: new benches for councillors, reclamation of some columns, complete renovation of the press room. A new crush bar and a small version of the corridor in the Lower House of Parliament where meetings and political negotiations can be held have also been created.

The benches function as working desks thanks to their monitors, USB ports and dongles to access the Internet and voting system. Finally, the two large screens installed at the president's sides display voting operations or live video.

The President of Rome City Council, Marco Pomarici, with the collaboration of the Head of the Secretariat Claudia Tonti, identified the project's strategic objective as technical innovation in the installed systems; this was realised with a strong technological contribution from ABB:

- The set up of specific lighting scenarios to automatically manage some pre-selected hall circumstances
- Automation of various processes, such as opening of high windows and movement of massive swinging lamps in steel and crystal, processes which were previously performed completely manu-

ally, with consequent waste of human resources and risk of errors

- Control and monitoring of all functions from a single workstation, allowing them to be monitored and accessed via a touch panel.

As well as the complexity of the works, there was also the strict requirement to give the utmost respect to the room's architectural heritage; this required special attention and precautions, such as protective coverings for the precious mosaic floor from Ancient Ostia.

All the functions created (automation of swinging lamps winches and window motors, lighting scenarios, dead man's safety switches, malfunctions alarms) can be managed from an ABB SMARTtouch screen, strategically located behind the President of the Council seat. System access is password-protected, with different accesslevels according to the user profile, and the room scenarios can be modified at any time.



01



The ABB SMARTtouch 6136/100C-102-500, located behind the President's seat, allows all the automated, motorised functions to be activated and set all scenarios appropriate for using the room.

### The KNX standard ensures versatility and quick personalisation

Implementing the system according to the KNX standard ensures a high degree of integration of the command and monitoring functions for the automated systems, guaranteeing maximum compatibility with a wide range of components and actuators rendering any further possible personalisations smoother. Now let us take a look at the most significant achievements in the Julius Caesar room.

### Power supply activation

The large amount of wooden furnishings in the council chamber increases the fire risk dramatically. With safety in mind, it is therefore very important that the sockets in the room are able to be deactivated automatically and via the touch-screen, as the manual deactivation switches are difficult to reach. In this way possible overloads and/or short-circuits are avoided when the hall is empty.

### A tonne of swinging lamps to be safely managed

The four swinging lamps in steel and crystal, each weighing around 250 kg, are attached to a vault 15 metres high. The need to move them carefully is met by an automated system of tackles which minimises vibrations and swaying. The two ABB i-bus KNX Switch Actuators SA/S 4.6.1 implement different safety systems. The first one, which is automatic, operates from 15 metres down to 2.5 metres, whereby power is deactivated before the swinging lamp reaches the limit of human height. The second, using a software access code, is instead operated in dead man mode or, in other words following continued manual pressure on a switch.



02

### Benefiting from halides without being left in the dark

Metal halide lamps have excellent colour rendering and the best energy efficiency for large areas. Automation ensures optimal management, preventing inconveniences caused by long restart time associated with these lamps. In fact, in the case of lamps being switched off by mistake, this intrinsic slowness prevents immediate reactivation causing prolonged periods of darkness, which are particularly embarrassing in public places.

In order to eliminate awkward interruptions, due to human error and to avoid oversights, the 12-channel 16A Switch Actuator SA/S 12.16.5 and lighting controls have been set up in lighting scenarios as precisely defined by the City Council according to how the hall is being used, whether it be for Council meetings, official ceremonies, exhibitions, cleaning, night-time or holidays.

### Opening windows more than ten metres high

The three valuable windows in the hall are located at a height of 10 metres. They are heavy, fragile and potentially dangerous and there is a risk that fragments or pieces of broken glass could fall on the people stationed below. The personalized automation of this process, thanks to the ABB i-bus KNX Switch Actuator 8.6.1, has been of great advantage.

The first benefit is that opening and closing is no longer managed by staff, who in the past had to access the windows from outside, by narrow and awkward ledges.

The above-mentioned actuators control the variable-speed motors which have a safety function (forced shut-down) which deactivates the motor when it exceeds a predetermined thrust value in case of obstacles, in this way avoiding strain and tension. Setting start and end-stroke values serves to keep the windows in the open or closed position, thus ensuring they do not swing freely and slam into the frames.



03

- 01 The Campidoglio has been a fundamentally important public building for the city of Rome for more than 2000 years.
- 02 Motorised automation allows opening of the 10 metre high windows and safe movement of the swinging lamps in steel and crystal, each weighing 250 kg, to be managed with ease.
- 03 The three large 10 metre high windows, had previously been opened and closed by staff who were forced to use narrow external walkways to do so. The motorisation facilitates their management and greatly increases worker safety.



# Professionals

## Technological Partners

### Global strategies and concepts

The President of Rome City Council,  
Marco Pomarici  
with the collaboration of the Head of the  
Secretariat Claudia Tonti  
Via del Campidoglio, 1  
00186 Rome

### Design, commissioning, testing and software

F.C. AUTOMAZIONI srl  
Giorgio Cecchini  
Via Gela, 79  
00182 Rome, Italy

### Installation and wiring

Domenicone Impianti srl  
Luciano Domenicone  
Via Pian di Sco, 88  
00139 Rome, Italy

### Electric material distributor

Elettrolazio srl  
Elvio Canale  
Via Carlo Buttarelli, 6  
00155 Rome, Italy

### Sales representative

**ABB S.p.A. – ABB SACE Division**  
**Rome Branch**  
Guido Tiseo



04

Finally, the customised automation allows partial opening of the windows based on the inside and outside temperatures and the number of people in the room. It is a solution which combines energy saving with a repeatable and well-defined standard of environmental comfort, eliminating maintenance and discretionary operations for the staff.

### Energy savings, greater safety, higher levels of comfort, versatility

This major technological innovation has therefore generated a series of advantages on various, complementary levels:

- Energy saving is achieved thanks to automated on/off function cycles. This solution prevents lighting being left on after events, on holidays, or when the area is sufficiently lit by natural light.
- Manual operations are drastically reduced, increasing the staff safety and efficiency
- Management and protection of the delicate and massive swinging lamps in steel and crystal using strict safety criteria

- Improvement in environmental comfort thanks to automated window management according to temperature variations in the hall
- Versatility and flexibility in implementing future functions such as:
  - Automated lighting of the square facing the Campidoglio Palace and all of the Capitoline Hill
  - Remote control of all functions in the hall, using Winswitch software
  - Energy-smart heating/air conditioning system management
  - Remote monitoring of the entire system: lighting outside and inside, the hall, windows, air conditioning/heating

04 Michelangelo Buonarroti completely redesigned the Campidoglio square, so that it now no longer looks towards the Roman Forum, but instead towards Saint Peter's Basilica, the new political centre of the city.



**Thomas Rodenbusch-Mohr**  
Product Marketing  
KNX Intelligent Building Control





Lightning protection specialists?

Absolutely.



Depending where we live, we are not all equal in front of the risk of lightning. For example there is more than 2 million lightning strokes per year on the French territory. They constitute a real risk for all humans and building structures. ABB as lightning protection specialist can offer you a range of lightning air terminals (simple rod or early streamer emission system OPR) in order to protect your facilities and personnel. All these products are developed by the ABB centre of excellence for lightning based in Bagnères de Bigorre - France; they are tested in laboratory as well as in situ to recreate natural conditions in the Pic du Midi (French Pyrenees).  
[www.abb.com](http://www.abb.com)

# Simplify design

With the complete AF contactor and motor protection range, panel builders, OEM's and many more can enjoy having their design and assembly process simplified. Reduced width and energy consumption helps save space, time and ultimately money.

Anders Hellgren: Marketing communication Account - Control and Protection

## Simplify design

When developing its new motor protection and power switching assortment, ABB took its customers' design processes into consideration. The goal was to simplify the process without compromising reliability or safety. The result: Fewer products with more features.

The new assortment ranges from 9 A, 4 kW/5 hp motor starting solutions all the way to our unique AF2650, the biggest single case block contactor in the world. Such breadth means that there are a lot of different aspects to consider when developing the range. What is common throughout the range though is the unique AF technology, which provides reliable switching regardless of network conditions as well as flexibility thanks to its wide voltage range.

## Wide voltage range

ABB has put a lot of effort into simplifying the selection of our products. It is now easier than ever finding an adequate product for just your application.

With conventional technology, separate coils were needed for different network voltages, frequencies or for direct current. No more. With the AF technology one coil covers 100 V-250 V and AC/DC and only four coils are required to cover the full span of 24 V-500 V AC/DC. The customer can use the same contactor in several network voltages, simplifying the choice of contactor as well as enabling a common design suited for a global market.

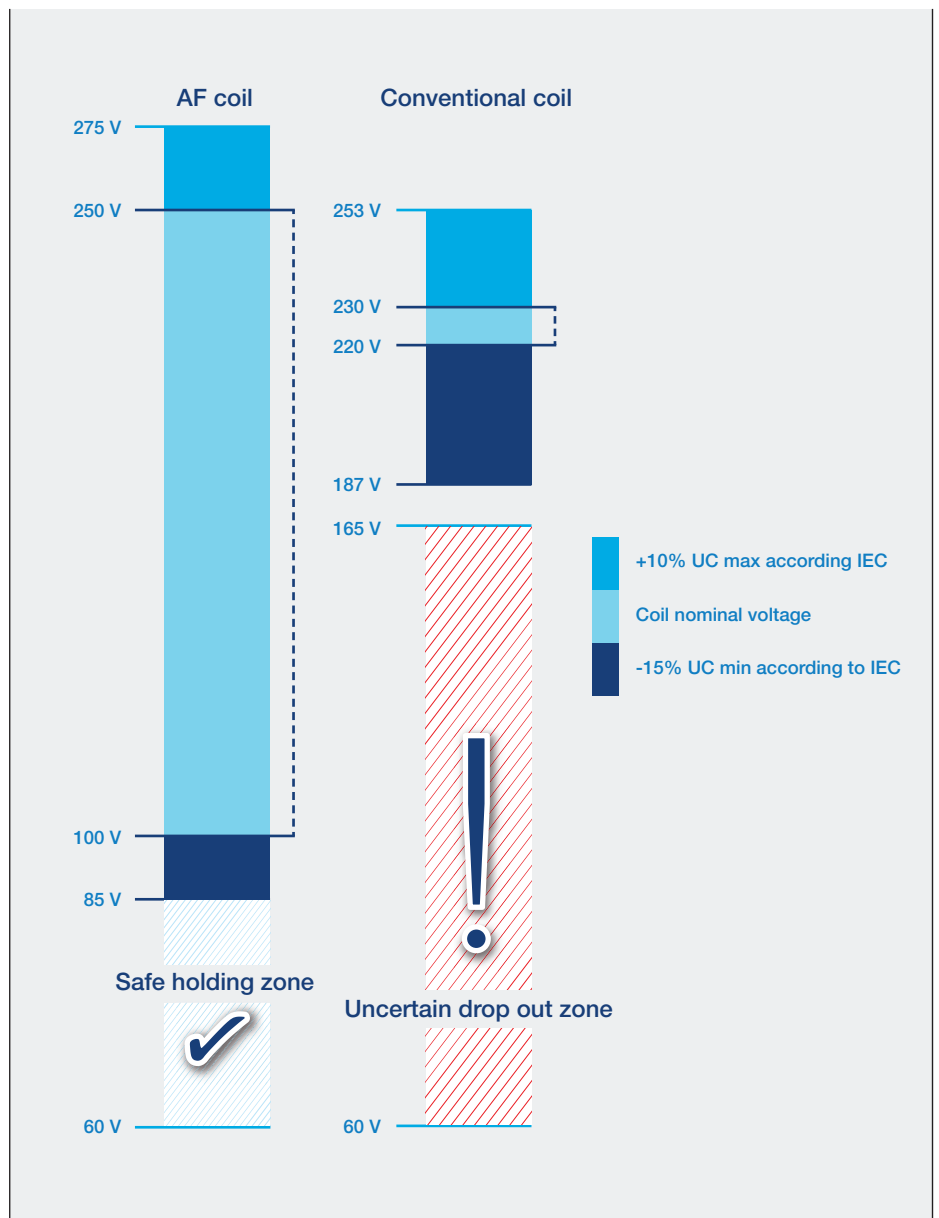

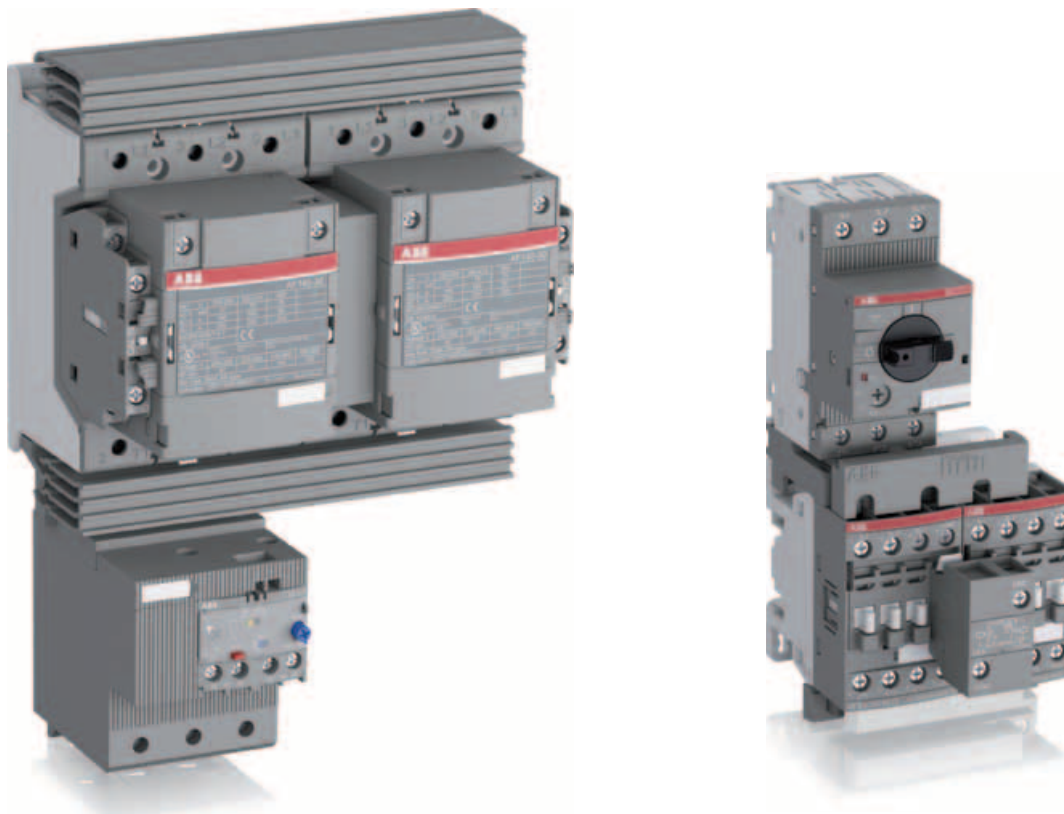

### Built-in surge suppressor

With conventional contactor technology it is recommended to use an external surge suppressor, an accessory that could cost as much as half the contactor itself. With the AF technology the surges are handled by the contactor itself and the surge never reaches the control circuit. Neither the surge suppressor nor the actual surge has to be considered anymore. One less product and one less complication to worry about.

### Energy consumption

The AF contactor is designed to use only the exact amount of power needed to keep the contacts securely closed – no less, no more. This has resulted in an 80% reduction in the coil's energy consumption. The products are also up to 30% more narrow. This sometimes allows for smaller panels and more compact transformers without turning to forced cooling.

### Mechanically matched

Whether you need a flexible contactor configuration, a breaker, an electrical- or thermal overload relay, ABB offers a complete and well-coordinated product assortment. We have the knowledge and experience to produce multi-product solutions just as reliable as the individual products.

### Electrically coordinated

ABB offers professionally coordinated starter solutions. The products are tested individually and in combination with others. This guarantees the starters functionality and the safety of products and persons. It also simplifies the selection of components for your application.

The coordination tables are available online, always updated with the latest data, making the design process of an efficient starting solution brief and effective.



**Anders Hellgren**  
Marketing communication Account  
Control and Protection

# Comparison of tripping characteristics for miniature circuit-breakers

The requirements for “Protection for safety – Protection against overcurrent” are specified in IEC 60364-4-43. Miniature circuit-breakers are used to protect cables in installations. They should disconnect automatically as soon as the combination of the current rise and duration causes the cable or a component to heat up excessively.

Florian Krackhecke: Product Marketing Manager - DIN Rail Products

Miniature circuit-breaker are used for:

- overload protection and
- short circuit protection in electrical circuits as well as
- protection against electric shock by automatic disconnection.

The disconnection is performed by two different releases. The instantaneous tripping by electro-magnetic release provides protection against short circuits. This is only dependent on current. The thermal bi-metal release is used for protection against overload. It trips by temperature rise, in other words both current and time.

When selecting miniature circuit-breakers for short-circuit protection in accordance with IEC 60364-4-43, the permissible let-through value  $I_2 \times t$  for extremely short disconnection times ( $<0.1s$ ) is contrasted with the Joulean heat impulse of the current  $k_2 \times S^2$  of the cable in order to verify whether sufficient protection is guaranteed in the event of a short circuit.

The combination of tripping curves of the electro-magnetic release and the thermal bi-metal release result in an overall tripping curve for overload protection. This curve – referred to the individual tripping characteristic – represents the time/current behavior of a miniature circuit-breaker.

The desire for the best protection, which requires miniature circuit-breakers to be highly sensitive, has to be reconciled with the different operating characteristics of the loads to be protected. Load current peaks must be permitted to pass unhindered, yet at the same time a disconnection must be ensured in the event of relatively low, but continuous, overloads. Various tripping characteristics are therefore available for circuit-breakers depending on the type of component or equipment to be protected:

- B, C and D for overcurrent protection of cables in accordance with IEC/EN 60898-1
- K for the protecting motors and transformers and simultaneous overcurrent protection of cables with overload tripping based on IEC/EN 60947-2
- Z for control circuits with high impedances, voltage converter circuits and semicable protection and simultaneous overcurrent protection of cables with overload tripping based on IEC/EN 60947-2

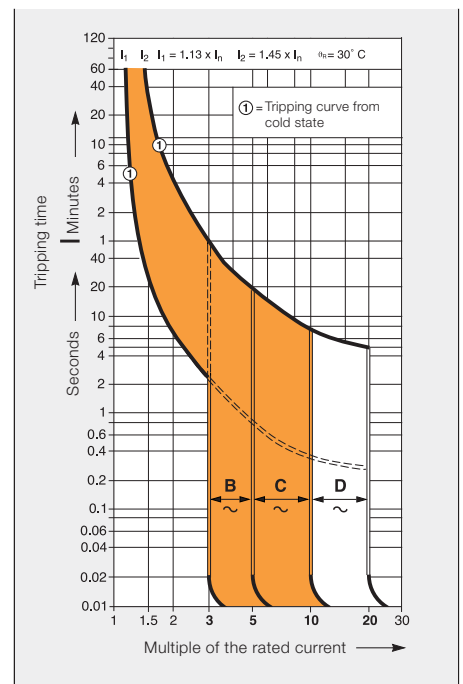



### Protection against short-circuits

Figure 1 shows typical let-through or  $I^2t$  values of overcurrent circuit-breakers. In the case of S201-B16 miniature circuit-breaker, this causes the let-through energy to be limited to approx. 20,000 A<sup>2</sup>s if a prospective short-circuit current  $i_k = 6$  kA occurs. This value is far less than 29,700 A<sup>2</sup>, meaning PVC-insulated Cu cables with a cross-section of 1.5 mm<sup>2</sup> can be protected in the event of a short-circuit.

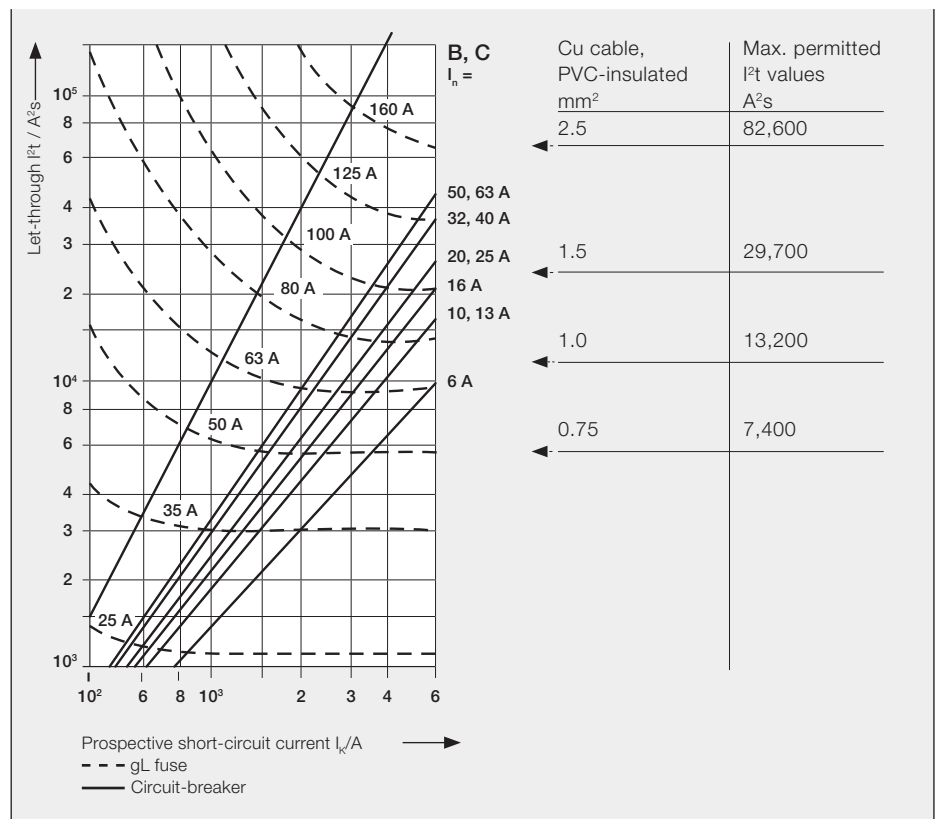

Figure 1 Let.-through energy I<sup>2</sup>t

### Overload protection in accordance with IEC 60364-4-43

For protection against overload, the protective device must be selected based on the current carrying capacity  $I_z$  of the cable:

$$I_b \leq I_n \leq I_z \quad (1)$$

$$I_2 \leq 1.45 \times I_z \quad (2)$$

$I_b$  = Design current of a circuit

$I_n$  = Rated current of the protective device

$I_z$  = Current carrying capacity of the cable in accordance with IEC/HD 60364-5-52

$I_2$  = Current ensuring effective operation in the conventional time of the protective device

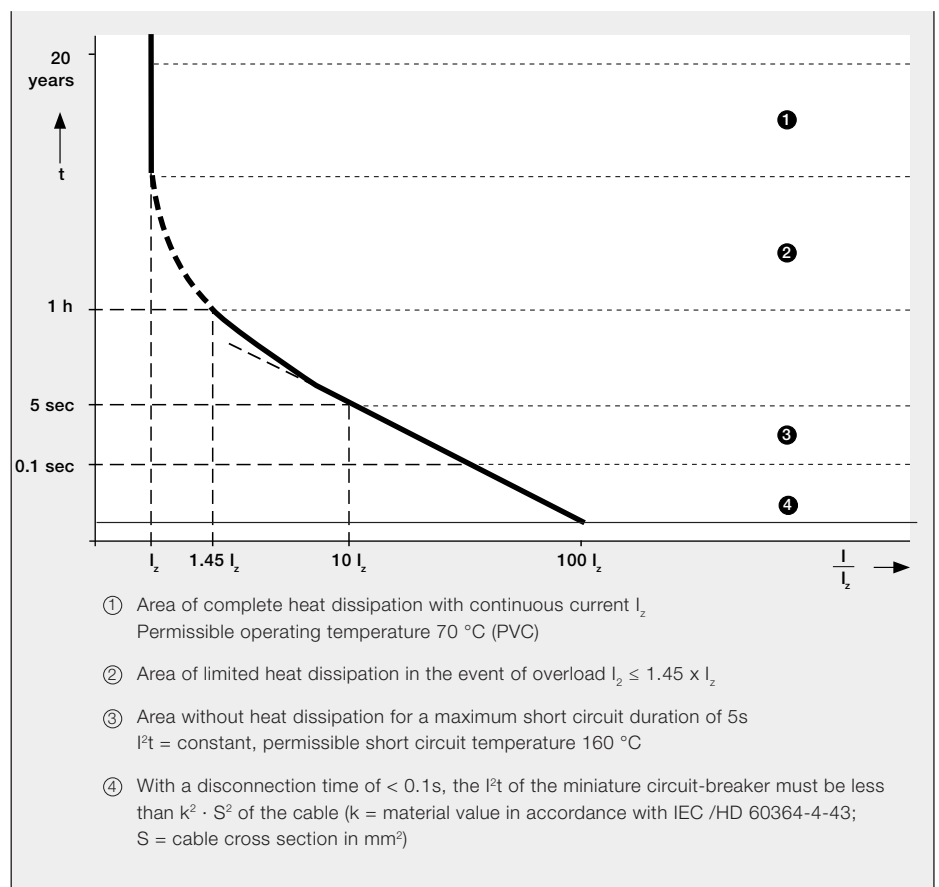

Figure 2 Load limit curve for PVC-insulated cables

**IEC 60364-4-43**

In individual cases, conditions (1) and (2) may not guarantee complete protection in accordance with the rules as afore-said may not assure protection in certain cases, for example where sustained over-currents less than  $I_2$  occur. In such cases, consideration should be given to selecting a cable with a larger cross-section area.

The general aim is to use the selected characteristic to protect a cable in accordance with its load capacity limit as shown in figure 2.

**Protection against overload**

Furthermore, protection devices with  $I_2$  values close to the rated current  $I_n$  can increase the effectiveness of overload protection significantly. Please refer in these cases to K- or Z-characteristic with  $I_2 = 1,2 \times I_n$ .

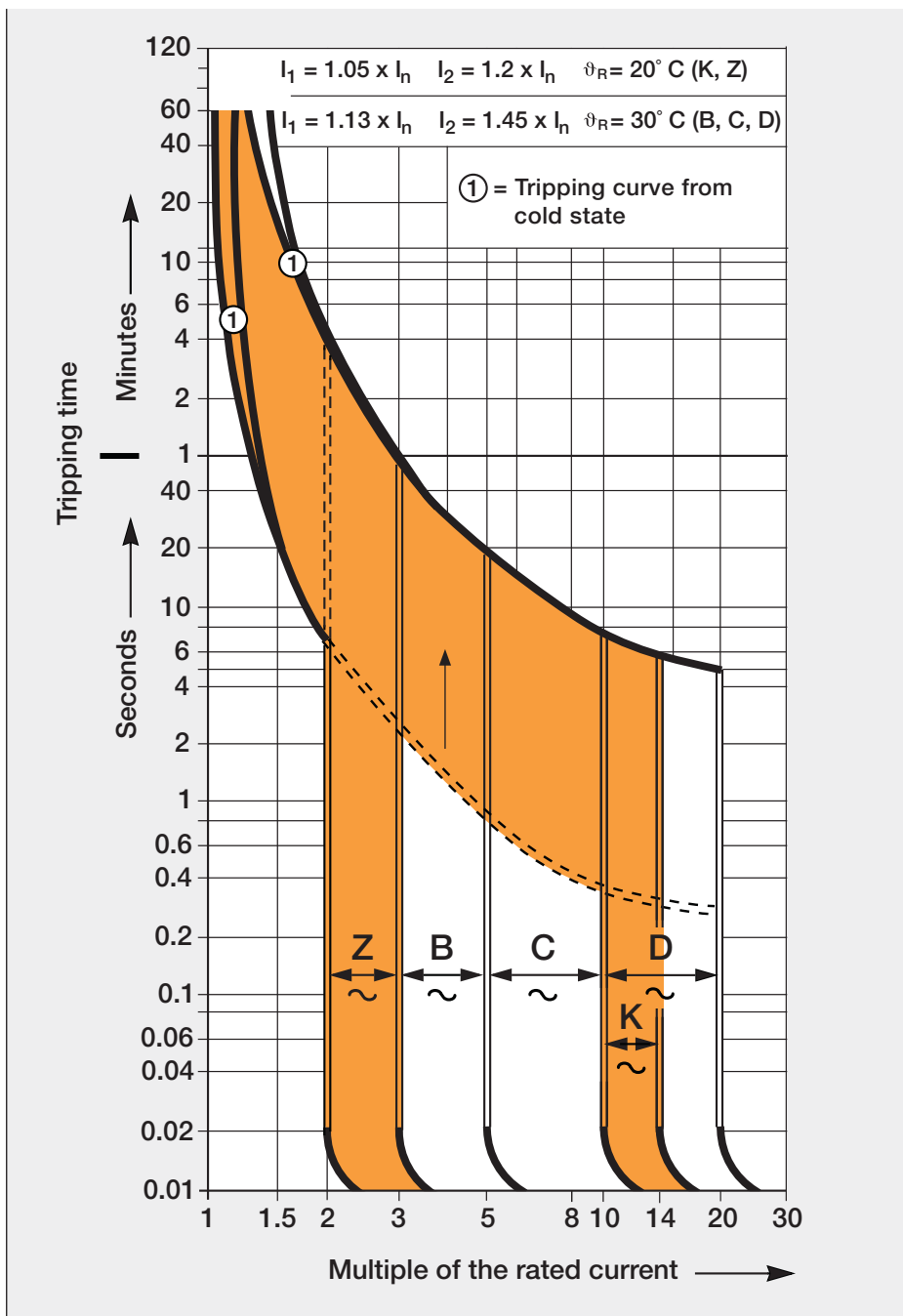

**Temperature of PVC-insulated cables at overload**

Load	Cable temperature*
$1.0 \times I_n$	70 °C
$1.2 \times I_n$	86 °C
$1.45 \times I_n$	116 °C

**Service life of PVC-insulated cables according to the Arrhenius equation**

Cable temperature	Service life
70 °C	20.0 years
90 °C	2.5 years
100 °C	1.0 year

\* 90% of the temperature value is reached from operating temperature after 5 minutes.

**Comparison of tripping characteristics “Z” and “B”**

**24 V DC control circuits**

In order to achieve the best possible protection of sensitive devices, such as contacts or prefabricated cables of sensors/limit switches, the instantaneous tripping must clear even low short-circuit currents within milliseconds.

The maximum cable lengths in relation to loop resistance must not be exceeded. Taking account of various parameters, the maximum cable lengths could be as follows:

1.5 mm<sup>2</sup>, two-wire, Cu:

- MCB B6 max. 10 m
- MCB Z2 max. 47 m
- MCB Z6 max. 18 m

Due to the low instantaneous tripping current, the maximum cable lengths can be realized by using the Z characteristic.

**Note**

With direct current, the tripping values of the electromagnetic releases are increased by a factor of 1.5.

**Protection against overload**

As stated before it is obvious that tripping characteristic “Z” provides better protection during operation and is easier to choose when planning.

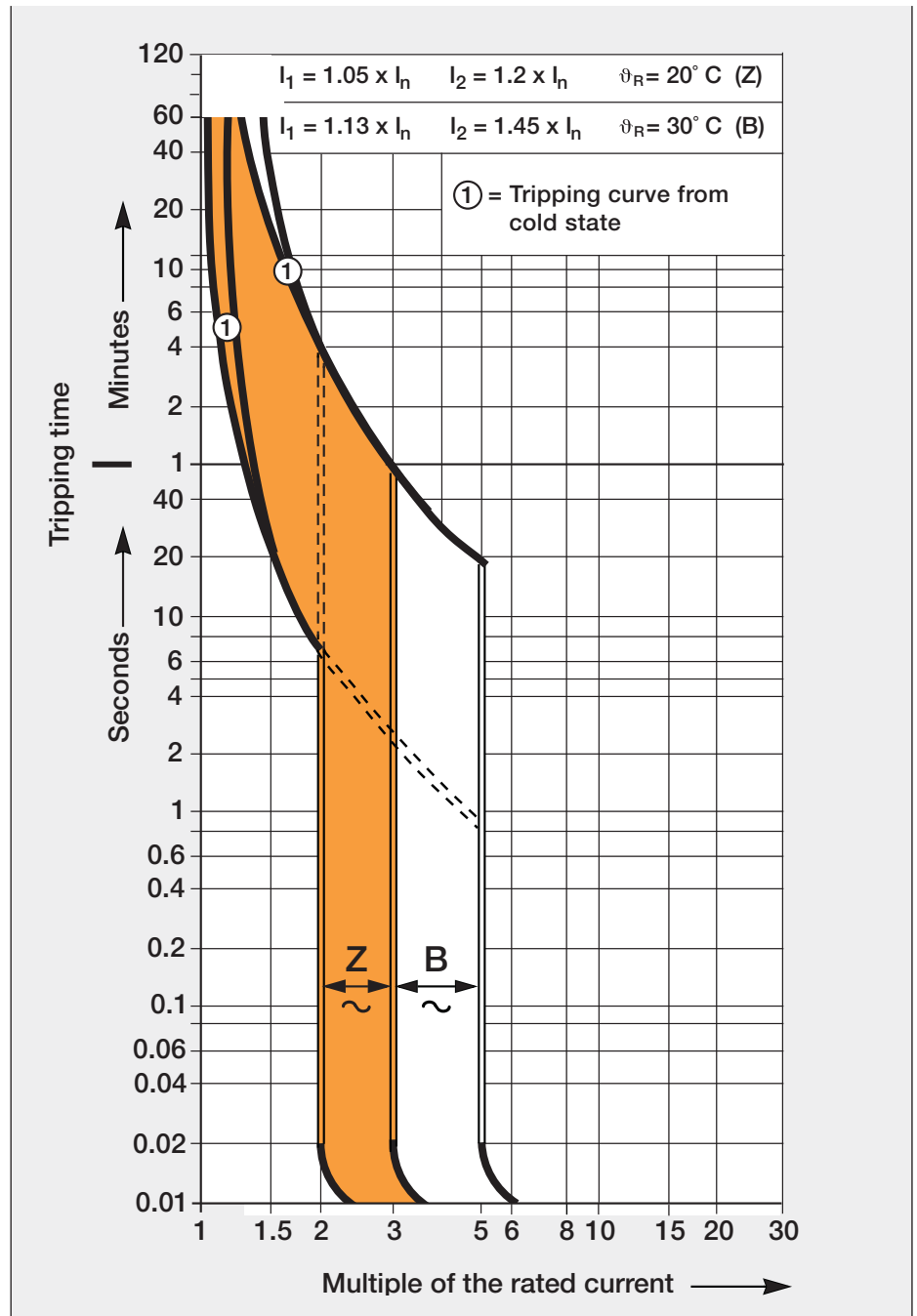

**Temperature of PVC-insulated cables at overload**

Load	Cable temperature*
1.0 x I <sub>n</sub>	70 °C
1.2 x I <sub>n</sub>	86 °C
1.45 x I <sub>n</sub>	116 °C

\* 90% of the temperature value is reached from operating temperature after 5 minutes.

**Service life of PVC-insulated cables according to the Arrhenius equation**

Cable temperature	Service life
70 °C	20.0 years
90 °C	2.5 years
100 °C	1.0 year

### Comparison of tripping characteristics “C” and “K”

“K” solves the conflict of service continuity in the event of peak currents and rapid disconnection in the event of a short-circuit.

In circuits where inrush currents or starting current peaks can occur due to motors, chargers, welding trans-formers, etc., tripping characteristic “K” has proven to be successful for more than 70 years.

Current peaks of up to  $10 \times I_n$  do not lead to unintentional disconnection. Tripping characteristic “C” only withstands current peaks of up to  $5 \times I_n$ .

#### Note

With direct current, the tripping values of the electromagnetic releases are increased by a factor of 1.5.

#### Protection against overload

As stated before it is obvious that tripping characteristic “K” provides better protection during operation and is easier to choose.

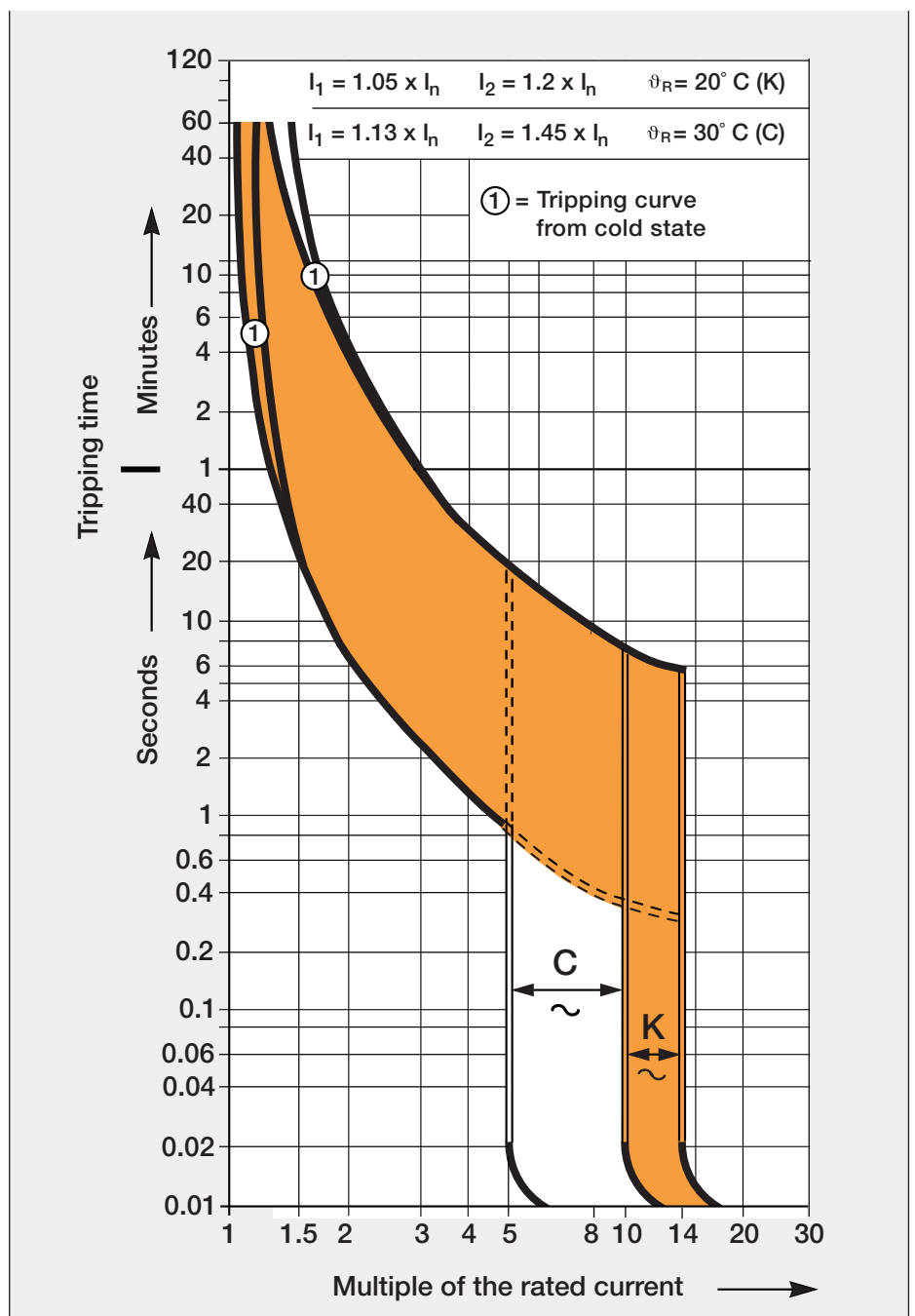

**Florian Krackhecke**  
Product Marketing Manager  
DIN Rail Products

#### Temperature of PVC-insulated cables at overload

Load	Cable temperature*
$1.0 \times I_n$	70 °C
$1.2 \times I_n$	86 °C
$1.45 \times I_n$	116 °C

\* 90% of the temperature value is reached from operating temperature after 5 minutes.

#### Service life of PVC-insulated cables according to the Arrhenius equation

Cable temperature	Service life
70 °C	20.0 years
90 °C	2.5 years
100 °C	1.0 year



### Comparison of tripping characteristics “K” and “D”

“K” solves the conflict of service continuity in the event of peak currents and rapid switch off in the event of a short circuit.

Tripping characteristic “K” trips at the latest at  $14 \times I_n$  in  $<0.1$  seconds. By contrast, tripping characteristic “D” disconnect the device at  $20 \times I_n$  in  $<0.1$  seconds, which could be a disadvantage both with regard to the loop re-resistance and for cable protection in the range from  $10-20 \times I_n$ .

#### Example

A socket is protected with a D16 miniature circuit-breaker. A minimum short-circuit current  $\geq 320$  A must be ensured in order to comply with the disconnection condition of  $\leq 0.4$  s for protection against electric shock.

#### Note

With direct current, the tripping values of the electromagnetic releases are increased by a factor of 1.5.

#### Protection against overload

As stated before it is obvious that tripping characteristic “K” provides better protection during operation and is easier to choose.

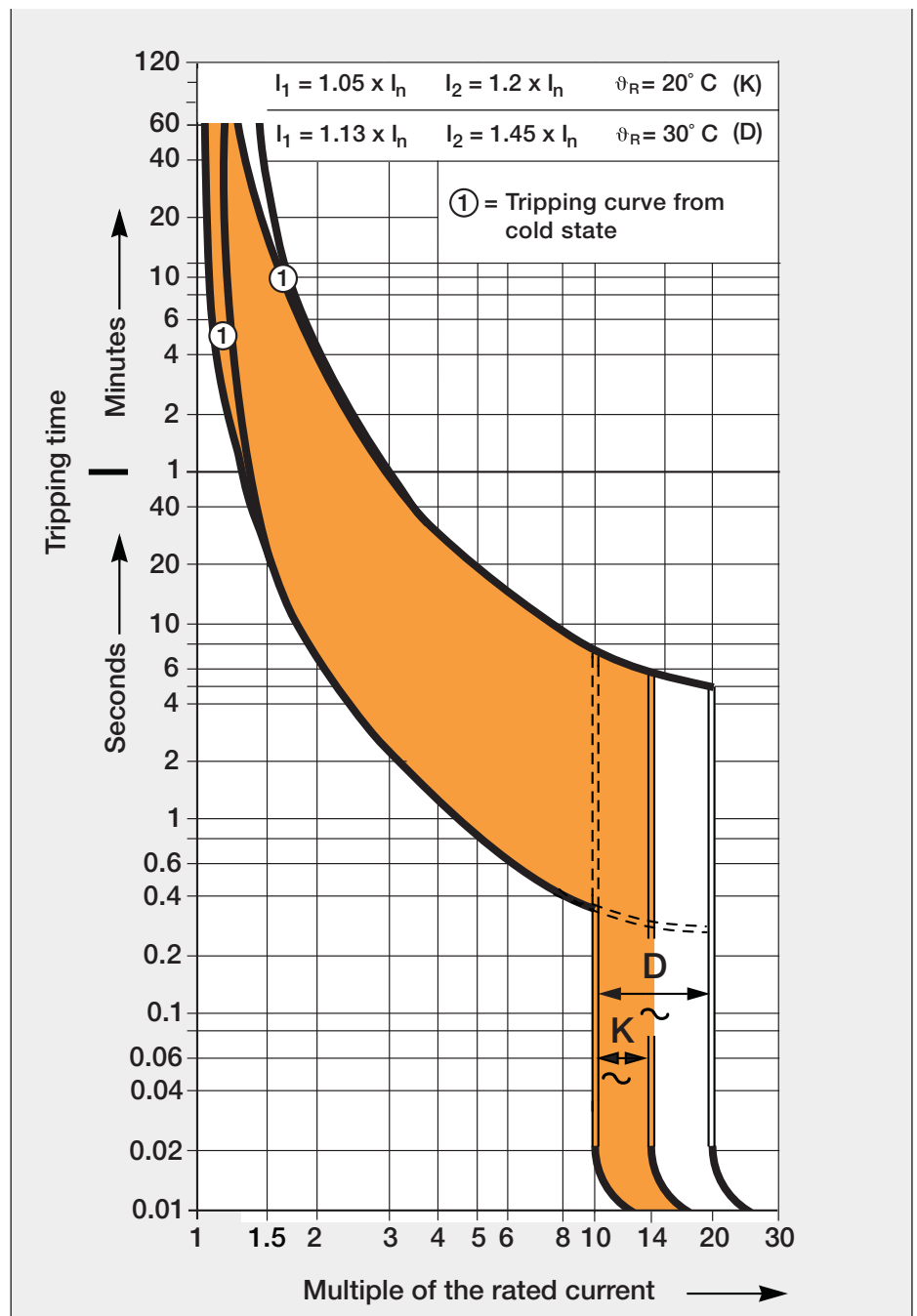

Temperature of PVC-insulated cables at overload

Load	Cable temperature*
$1.0 \times I_n$	70 °C
$1.2 \times I_n$	86 °C
$1.45 \times I_n$	116 °C

Service life of PVC-insulated cables according to the Arrhenius equation

Cable temperature	Service life
70 °C	20.0 years
90 °C	2.5 years
100 °C	1.0 year

\* 90% of the temperature value is reached from operating temperature after 5 minutes.

**Tripping characteristics B, C, D, Z, K**

Compared with tripping characteristics “B”, “C” and “D”, “K” and “Z” provide better protection during operation and is easier to choose.

**Assignment**

- B, C and D for overcurrent protection of cables in accordance with IEC/EN 60898-1
- K for protecting windings in motors and transformers and simultaneous overcurrent protection of cables
- Z for control circuits with high impedances, voltage converter circuits and simultaneous overcurrent protection of cables

**Other criteria when selecting miniature circuit breakers**

In order to protect a circuit optimally, additional considerations and constraints must be considered when selecting the miniature circuit-breakers.

**Deviating ambient temperature**

For installations of miniature circuit-breakers at other temperatures than the reference value, derating factors have to be considered. The rated value of the current of a miniature circuit-breaker refers to a reference ambient temperature of 30 °C for miniature circuit-breakers with the characteristics B, C and D and 20 °C for miniature circuit-breakers with the characteristics K and Z. If the ambient temperature is higher, the maximum operating currents are reduced by approx. 6 % per +10 °C temperature difference. For precise calcu-

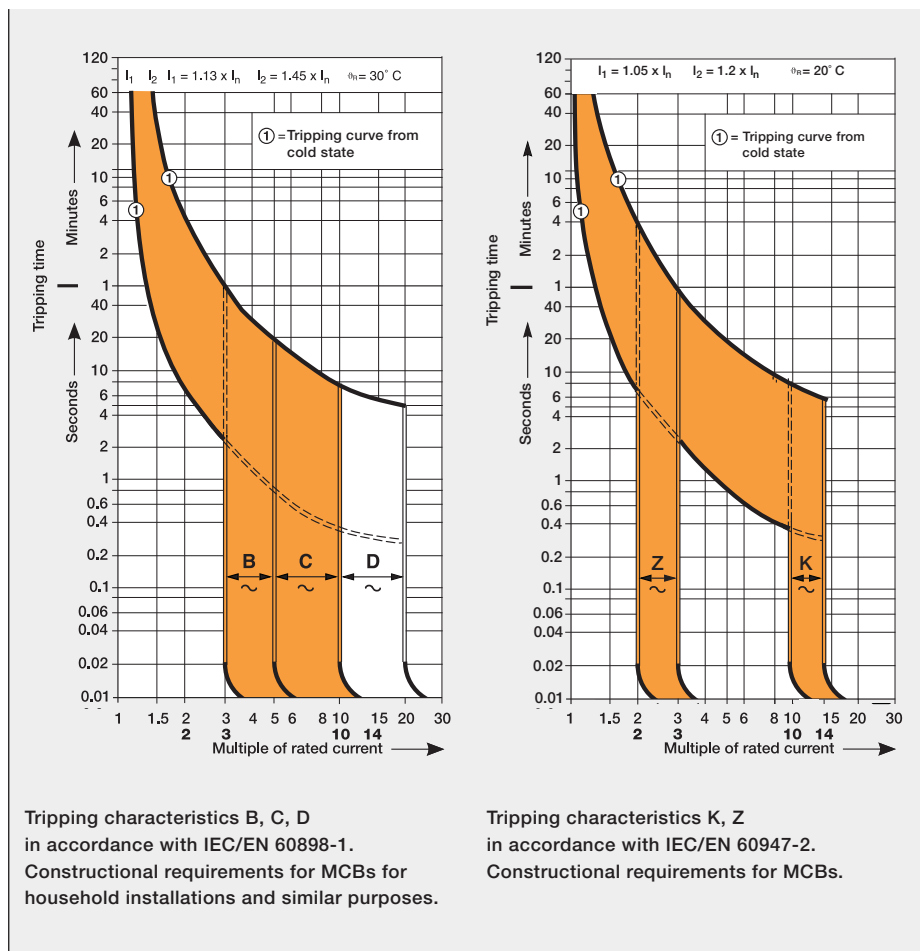

lations and extremely high or low ambient temperatures, reference tables must be consulted.

**Influence of adjacent devices**

If several miniature circuit-breakers are installed directly side by side with high load on all poles, a correction factor has to be

applied to the rated current (see table). If distance pieces are used, the factor is not to be considered.

No. of adjacent devices	Factor F
1	1
2, 3	0.9
4, 5	0.8
≥ 6	0.75

**Tripping characteristics**

Acc. to	Tripping characteristics	Rated current $I_n$	Thermal release <sup>1)</sup>			Electromagnetic release <sup>2)</sup>		
			Currents: conventional non-tripping current $I_1$	conventional tripping current $I_2$	Tripping time	Range of instantaneous tripping	Tripping time	
IEC/EN 60898-1	B	6 to 63 A	$1.13 \cdot I_n$	$1.45 \cdot I_n$	> 1 h < 1 h <sup>3)</sup>	$3 \cdot I_n$ $5 \cdot I_n$	0.1 ... 45 s ( $I_n \leq 32$ A)/0.1 ... 90 s ( $I_n > 32$ A) < 0.1 s	
	C	0.5 to 63 A	$1.13 \cdot I_n$	$1.45 \cdot I_n$	> 1 h < 1 h <sup>3)</sup>	$5 \cdot I_n$ $10 \cdot I_n$	0.1 ... 15 s ( $I_n \leq 32$ A)/0.1 ... 30 s ( $I_n > 32$ A) < 0.1 s	
	D	0.5 to 63 A	$1.13 \cdot I_n$	$1.45 \cdot I_n$	> 1 h < 1 h <sup>3)</sup>	$10 \cdot I_n$ $20 \cdot I_n$	0.1 ... 4 s ( $I_n \leq 32$ A)/0.1 ... 8 s ( $I_n > 32$ A) < 0.1 s	
IEC/EN 60947-2	K	0.5 to 63 A	$1.05 \cdot I_n$	$1.2 \cdot I_n$	> 1 h < 1 h <sup>3)</sup>	$10 \cdot I_n$ $14 \cdot I_n$	> 0.2 s < 0.2 s	
	Z	0.5 to 63 A	$1.05 \cdot I_n$	$1.2 \cdot I_n$	> 1 h < 1 h <sup>3)</sup>	$2 \cdot I_n$ $3 \cdot I_n$	> 0.2 s < 0.2 s	

<sup>1)</sup> The thermal releases are calibrated to a nominal reference ambient temperature; for B, C, D the reference value is 30 °C, for K and Z the reference value is 20 °C.

In the case of higher ambient temperatures, the current values fall by approx. 6 % for each 10 K temperature rise.

<sup>2)</sup> The indicated tripping values of electromagnetic tripping devices apply to a frequency of 50/60 Hz. The thermal release operates independent of frequency.

<sup>3)</sup> As from operating temperature (after  $I_1 > 1$ h)



## ABB i-bus® KNX Room Master. Your first step into the KNX world



Bridging the gap between conventional electrical installations and KNX world, Room Master devices offer electrical connections and control features required in defined functional areas like apartments, hotel rooms, schools or retail stores. With the internal connection of inputs and outputs, done by ETS software, planning, installation and putting into operation new electrical installations are substantially facilitated. The Room Master concept opens the door to KNX Intelligent Building Control with flexible, project specific expendabilities for residential and commercial properties. [www.abb.com/knx](http://www.abb.com/knx)

# Bring together selectivity, back-up and service continuity

## One device for selectivity & back-up protection

Roland Heinrich Prügel: *Product Manager - Solutions*

### Introduction

The S800-SCL-SR (Self-Resetting Short-Current Limiter) is not a usual power circuit-breaker. With this device full selectivity and back-up protection is given at the same time in one device.

Power circuit-breakers are usually covering either partial selectivity or the back-up protection, but not both. Thus S800-SCL-SR is one major advantage for your solution. Furthermore the S800-SCL-SR is a coordinated device helping a wide range of downstream devices to limit the current during short-circuit events. After the downstream device has tripped, the S800-SCL-SR contacts re-close automatically. All other downstream devices work without interruption.

Thus continuity is given during the short-circuit for all downstream loads except the faulty branch. In addition the short-circuit breaking capacity will be increase dramatically (back-up) without losing any selectivity (total selectivity).

### Application examples

The application fields are nearly unlimited for the S800-SCL-SR. In case of high short-circuit current levels the S800-SCL-SR helps to increase the system reliability and reduce material costs (conductor/cable). Especially at higher system voltages up to 690V AC and high prospective short-circuit currents up to 100kA protection is given.

Electric circuit examples as illustrated in figure 1 are realized today with the S800-SCL-SR in an excellent way.

### Benefits

- Selectivity and back-up protection in one device
- Upgrades systems up to 100kA
- High voltage range up to 690V AC
- Group protection without interruption
- Intelligent: Automatic re-closing of the limiter contacts after fault clearing
- Less copper costs through excellent electrical let-through values



Roland Heinrich Prügel  
Product Manager - Solutions

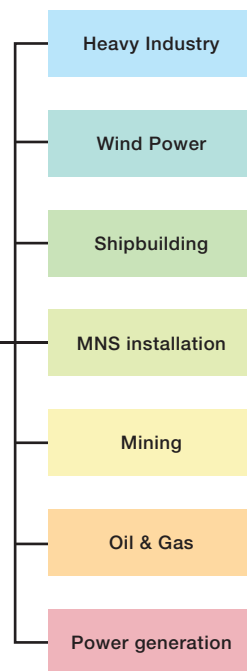



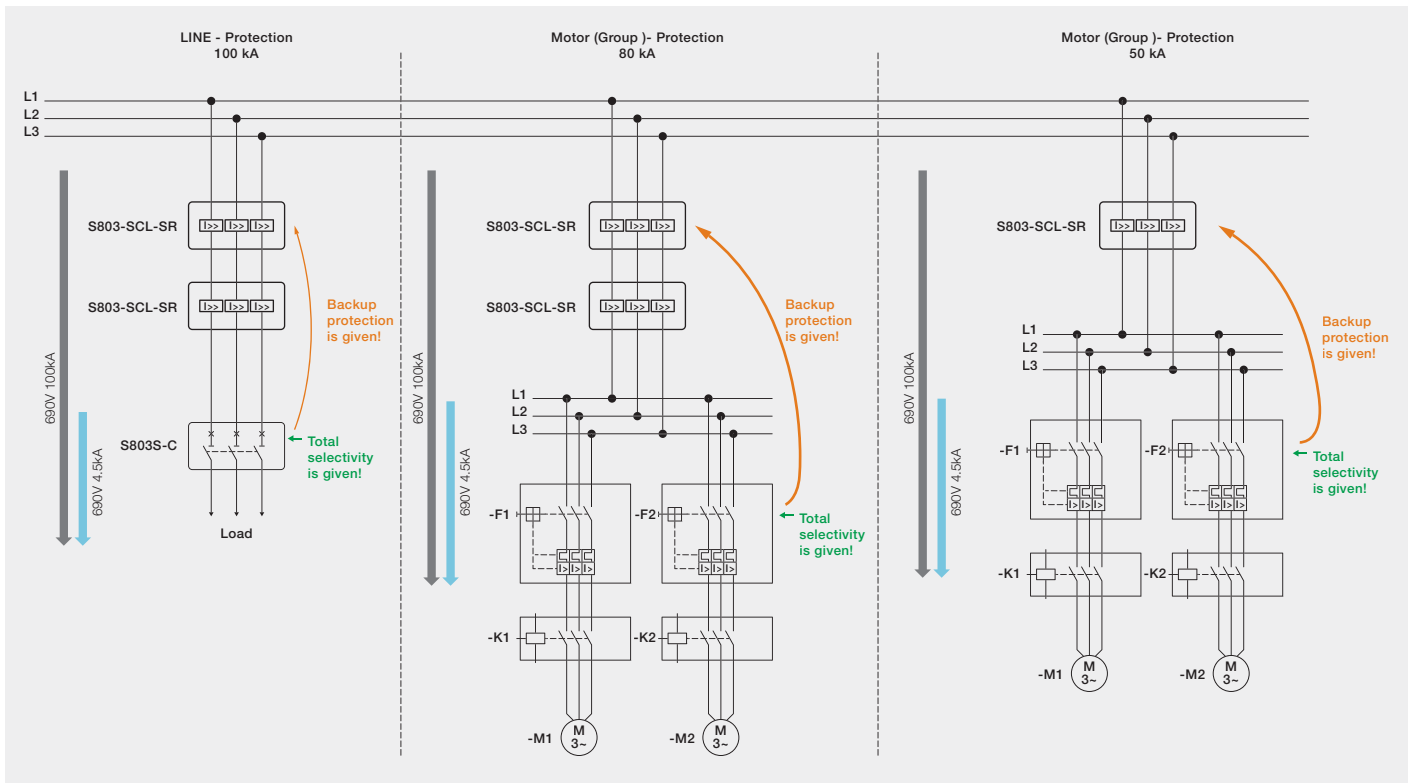

Figure 1 Schematic circuit diagram examples up to 100A rated current

### Benefits and Advantages

Figure 1 illustrates the excellent benefit of the S800-SCL-SR and the opportunity for considerable cost reduction.

The innovation of this device is the ability to provide full selectivity and back-up at the same time. As can be seen in figure 1, the group protection of multiple motor starters makes this system especially attractive.

Another advantage is the high current limiting performance. In case of a short-circuit the I<sub>2t</sub>-value is very low compared with conventional power circuit breakers. Figure 2 explains this feature. In consequence is a much lower let-through energy respectively less heat and damage is achieved.

### Summary

- Total selectivity and backup protection at the same time
- High current limiting functionality

### Back-up protection

Back-up protection is given when an upstream protection device assists the downstream protection device in a coordinated way. Thus the short-circuit breaking capacity of the combination is appropriate whereas the downstream protection device is not sufficient. Both protection devices trip.

In case of exceeding the switching capacity with reference to the direct located MCB, the superordinated MCB (e.g. a S800-SCL-SR or a S800S) turn off or help. The protection of both electrical circuits is given. Both of them are fully functional.

### Selectivity

Selectivity is achieved if the upstream protection device of two or more coordinated protection devices will not trip. Only the protection device nearest the fault will trip. Selectivity may be either partial or total.

Information for selectivity, back-up protection and coordination tables are provided by the manufacturer. See page 55.

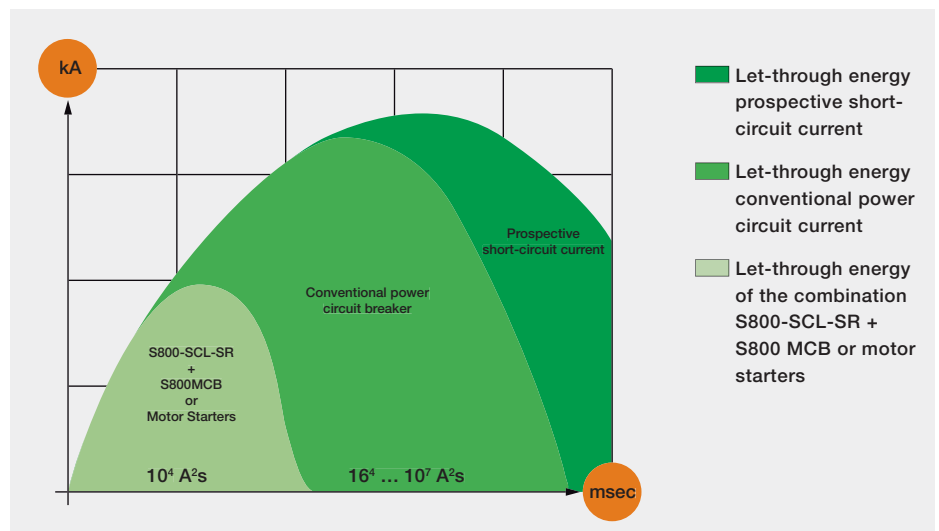



**Application:**  
**Line protection & motor protection**

Two serial S800-SCL-SR in combination with a motor starter or a S800 high performance circuit breaker are suitable for operation up to 690V and 100A rated current for circuits up to 100kA prospective short-circuit current. This combination rating is considerably higher than the rating of the protection devices alone. For example a typical motor starter alone has a short-circuit rating of 3kA at 690V.

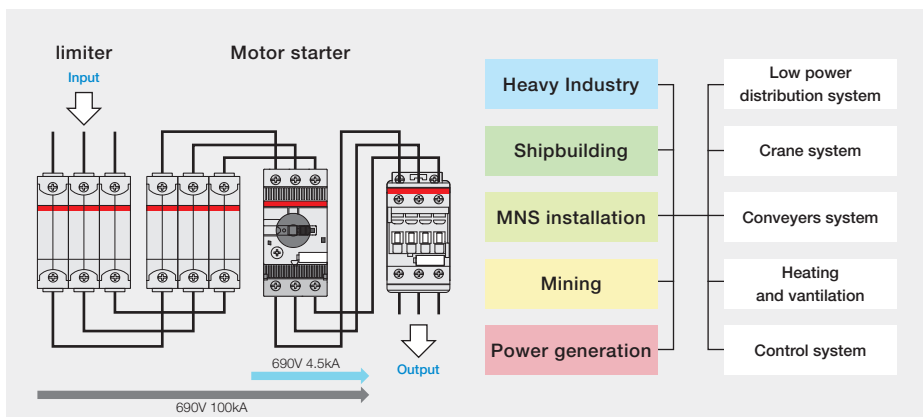

**Application:**  
**Motor group protection**

The major advantage of S800-SCL-SR is the ability for group protection. The S800-SCL-SR protects all downstream devices up to 100kA. In case of a fault current in one of the motor circuits the resulting short-circuit current is limited and only the faulty branch is cut off. After the downstream device has tripped, the S800-SCL-SR contacts re-close automatically. All other downstream devices continue to operate without interruption.

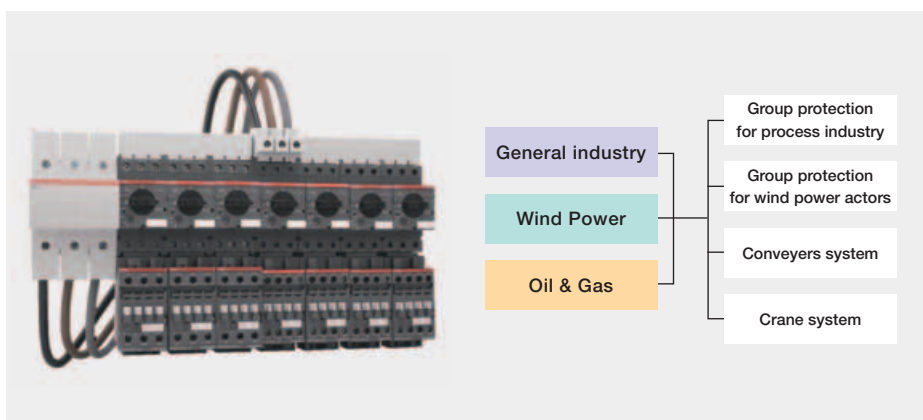

**Guideline for selection of coordination tables**

Step 1: Select hyperlink: <http://applications.it.abb.com/SOC>

Step 2: Selection of required application

Protection Device	Rated Voltage	Short-Circuit Current [kA]	Starter Type	Coordination Type	Overload Relay	Motor Rated Power [kW]/[HP]
All	All	All	All	All	All	Overview
ACB	240Vac	3	DOL-NS	IEC Type 1	Embedded	0
Fuses	400Vac	5	DOL-HD	IEC Type 2	TOL	0.06
MCCB	415Vac	10	SD-NS	UL Type A	EOL	0.09
MMS	440Vac	12	SS-NS-IL	UL Type C	UMC	0.12
	460Vac	16	SS-NS-ID	UL Type D		0.18
	480Vac	18	UL	UL Type E		0.25
	500Vac	20		UL Type F		0.37
	525Vac	22		UL Component		0.5
	600Y/347Vac	25				0.55
	600Vac	27				0.75
	690Vac	30				1
	1000Vac	35				1.1
		36				1.5
		40				1.8

Step 3: Selection of motor starter type

MMS, 690 Vac, 50 kA, DOL-NS, Coordination Type IEC Type 2, Overload Relay EOL + Back-up / Limitor

Motor		Manual Motor Starter		Back-up / Limitor	Contactor	Overload Relay		Table	
Rated Power [kW]	Rated Current [A]	Type	Instantaneous Tripping Current [A]	Type	Type	Type	Current setting range [A]	Max allowed load current [A]	
0.09	0.17	MO325-0,25	2.44		A9	E16DU0,32	0.10 - 0.32	0.25	>>
0.09	0.17	MS325-0,25	2.44		A9	E16DU0,32	0.10 - 0.32	0.25	>>
0.09	0.17	MS325-0,25	2.44		A9	UMC22/100	0.24 - 63.00	0.25	>>
0.18	0.35	MO132-0,40	3.90		AF09	EF19-1,0 10 ***	0.30 - 1.00	0.40	>>

Step 4: Selection of required coordination table

Table name: MMS - 690Vac - 50kA - DOL-NS - IEC Type 2 - MO132 + EOL

SCPD type: MMS

Starting type: DOL-NS

Disconnecting Mean present: no

Frequency: 50-60 Hz

Rated voltage: 690Vac

Coordination type: IEC Type 2

Backup / limiter present: yes

Edited on date: 06.12.2012

Short circuit current: 50kA

Overload relay: EOL

Current Transformer present: no

[Export to PDF](#) | [Print](#)

Motor		Manual Motor Starter		Back-up / Limitor	Contactor	Overload Relay		Table
Rated Power [kW]	Rated Current [A]	Type	Instantaneous Tripping Current [A]	Type	Type	Type	Current setting range [A]	Max allowed load current [A]
0.18	0.35	MO132-0,40	3.90		AF09	EF19-1,0 10***	0.30 - 1.00	0.40
0.25	0.49	MO132-0,63	6.14		AF09	EF19-1,0 10***	0.30 - 1.00	0.63
0.37	0.64	MO132-1,0	11.50		AF09	EF19-1,0 10***	0.30 - 1.00	1.00
0.55	0.87	MO132-1,0	11.50		AF09	EF19-1,0 10***	0.30 - 1.00	1.00
0.75	1.10	MO132-1,6	18.40		AF09	EF19-2,7 10***	0.80 - 2.70	1.60
1.10	1.60	MO132-2,5	28.70		AF09	EF19-2,7 10***	0.80 - 2.70	2.50
1.50	2.10	MO132-2,5	28.70		AF09	EF19-2,7 10***	0.80 - 2.70	2.50
2.22	2.80	MO132-4,0	50.00	S803S-SCLxSR (*)	AF26	EF19-6,3 10***	1.90 - 6.30	4.00
3.00	3.80	MO132-4,0	50.00	S803S-SCLxSR (*)	AF26	EF19-6,3 10***	1.90 - 6.30	4.00
4.00	4.90	MO132-6,3	78.70	S803S-SCLxSR (*)	AF26	EF19-6,3 10***	1.90 - 6.30	6.30
5.50	6.70	MO132-10	125.00	S803S-SCLxSR (*)	AF26	EF19-18,9 10***	5.70 - 18.90	10.00
7.50	8.90	MO132-10	125.00	S803S-SCLxSR (*)	AF26	EF19-18,9 10***	5.70 - 18.90	10.00
9.00	10.70	MO132-12	150.00	S803S-SCLxSR (*)	AF26	EF19-18,9 10***	5.70 - 18.90	12.00
11.00	12.80	MO132-16	200.00	S803S-SCLxSR (*)	AF26	EF19-18,9 10***	5.70 - 18.90	16.00
15.00	17.00	MO132-20	250.00	S803S-SCLxSR (**)	AF26	EF19-18,9 10***	5.70 - 18.90	17.00
15.00	17.00	MO132-20	250.00	S803S-SCLxSR (**)	AF30	EF45-30 10***	9.00 - 30.00	20.00
18.50	21.00	MO132-25	313.00	S803S-SCLxSR (**)	AF30	EF45-45 10***	15.00 - 45.00	21.00
22.00	24.00	MO132-25	313.00	S803S-SCLxSR (**)	AF38	EF45-45 10***	15.00 - 45.00	24.00

(\*) Types 32, 63 or 100A; (\*\*) Types 63 or 100A; (\*\*\*) selected trip class of Electronic overload relay

# S200 Miniature circuit breakers... over the top!

The S 200 series MCBs are suitable for installation at high altitudes ...

Florian Krackhecke: Product Marketing Manager - DIN Rail Products

The S 200 series MCBs do not suffer any change to their rated performance at up to 2,000 metres altitude.

At higher altitudes, the properties of the atmosphere change in terms of its composition, dielectric capacity, heat transfer, pressure, meaning that in order to correctly install and calculate the breakers it is sufficient to consider a derating which can essentially be measured through the variation of important parameters such as rated current and voltage (see table).

And the low temperatures at such high altitudes? No problem!

S 200 MCBs can be used down to  $-25\text{ }^{\circ}\text{C}$ , considering the rated current derating by temperature tables which can be found in the System pro M compact® technical catalogue.

## S 200

Altitude	m	2.000	3.000	4.000
Operating voltage $U_e$	V	440	380	380
Rated current $I_n$	A	$I_n$	$0,96 \times I_n$	$0,93 \times I_n$



The ABB S 201 MCB







Is it possible to switch off AC / DC?

Certainly.



The S200 MUC impresses with its performance range and the accordingly large amount of approvals. Its high inbuilt short circuit breaking capacity across the entire model line, its flexible application for both direct and alternating currents and its approval and compliance in accordance with all major international and local standards make it truly unique. The miniature circuit breaker is a valuable addition to the existing System pro M compact® range which allows all known components to be combined effortlessly with the new model line. Whether warehousing and project engineering, planning and installation or maintaining your equipment, the S200 M UC is a simple and flexible solution. For more information, see [www.abb.com](http://www.abb.com)





# Building automation in the bank

For the extremely original “orange bank”, adopting the most innovative building automation solutions for controlling power supplies and the automation system was a natural step.

Francesca Sassi: *Product Marketing Manager - DIN Rail Products*

Offering simple, transparent products with economically advantageous terms has been ING DIRECT's only mission since it was founded in Canada in 1997. The largest direct bank in the world, it has been on the Italian marketplace since 2001.

This strong attention to customer needs requires a corporate culture based on flexibility and being open to the most innovative solutions, in order to be constantly on the look-out for new opportunities. This point of view led to the decision to open more than 20 branches in the main towns in Italy, starting in 2011, in order to provide further opportunities to access the bank's services and consultancy, which are also provided via the web and the other most modern communication systems.

The term “branch”, however, is a little limiting for the bank's new functional environments, much less in-keeping with a typical high-street bank and more like a concept store, in which operations are strongly characterised by self-service thanks to the introduction of the most up-to-date technological solutions, such as automatic tellers and interactive terminals. The former allow customers to check their accounts, withdraw and deposit money and cheques without the limitations of normal ATMs; the interactive terminals allow them to manage their visit and consult information via tablet PCs while waiting for one of the agents, specialised operators who can explain the products and services as well as perform all typical banking operations, if required, instead of the self-service mode.



## Connected to the building automation system

Two of the ABB i-bus® KNX components used deserve a special mention.

The DualLine 6131/10-24 motion detector allows lighting to be turned off and on on the basis of ambient light and the presence of people. Installed at 2.5 m height, it has a detection range of approximately 3 m. The brightness field is 0 – 1000 Lux.



The SW/S 4.5 4-channel time switch allows switching of electrical loads to be programmed, and the dimmers sent pre-set brightness values, sending time and date information for synchronising the other devices over KNX bus.



01 The interior architecture is inspired by criteria of brightness, transparency and accessibility. The environments are modern and welcoming, thanks to the warm colours and materials used.

In a situation where typical branch operations are quick and free, unlike most Italian banks – it is possible to set up and activate an account and payment cards in 15 minutes – and where paper documentation is not used, as customers confirm operations by entering their access credentials used for direct channels, even the electrical system choices have a strong technological stamp. A building automation system based on the international KNX standard supplied by ABB has indeed been used to monitor and control the lighting and mains circuits of the branches, managed by a SAET GEMMS supervisor system developed by a system integrator partner of ABB.

### Comfortable and welcoming environments

The concept-store style architectural project was inspired by three precise characteristics required by ING DIRECT: brightness, transparency and accessibility.

Large windows lit also at night, entrances free of the security buzzers common in Italy and often viewed with annoyance by customers, and the use of warm, modern colours and materials, such as orange and wood, create a modern and, at the same time, pleasant and welcoming environment, without the “coldness” which so often distinguishes traditional bank branches.

The lights naturally cover an essential function, and it is precisely this aspect which the functional design of the building automation system concentrated on primarily.

The fundamental criterion was to allow centralised technical management from the operations centre in Milan, from where it is possible to control the power supply lines for the lighting and power for all branches.

The operations centre controls daily turning on, in the morning, and turning off of branches at night, while time switches

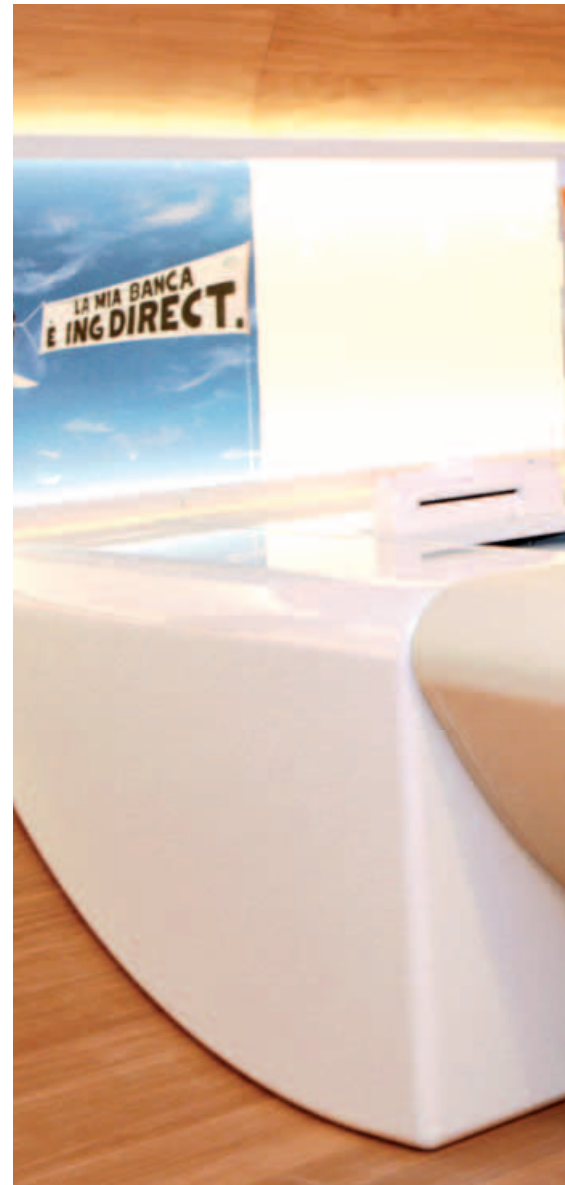

01

and motion detectors are installed locally for appropriate regulations during the daily activities.

Both these devices are supplied by ABB and are connected to the building automation system. The KNX FW/S time switches are able to send commands to turn equipment on and off and adjust the brightness values of the dimmers according to the programmed times. The KNX 6131 motion detectors turn the lights off and on based both on whether people are present and the level of lighting in the establishment.

The integrated time switch and motion detector functions allow lighting requirements during different times of day to be met, while avoiding electricity being needlessly wasted. The internal lighting in the offices and the external window lighting are managed by these controls.





### Advantageous technological choices

Another function assigned to the building automation system is controlling the protective breakers installed in the electrical panels of the branches. Here too, the components inside the panels (MCBs and RCDs, SPDs, switches and breakers) are supplied by ABB, offering the advantage of a single supplier for all essential electrical distribution components, as well as the automation system.

The breakers and other devices are controlled via a KNX US/U input device which the auxiliary signalling contacts are connected to; in the case of tripping due to surges or other causes, the breaker concerned can be seen in the operations centre, allowing a technical assistance call to be sent out. The high-technology project solutions have given an important added value to management of the systems, despite the higher level of complexity when compared to simpler, traditional wiring solutions.

The central management allows efficient and more precise technical monitoring across the whole structure composed of the new branches, optimising service and maintenance operations for them and facilitating the creation of new ones beside the existing ones.

Energy efficiency can also be monitored, thanks to the electrical meters in the branches connected to the building automation system.



**Francesca Sassi**  
Product Marketing Manager  
DIN Rail Products

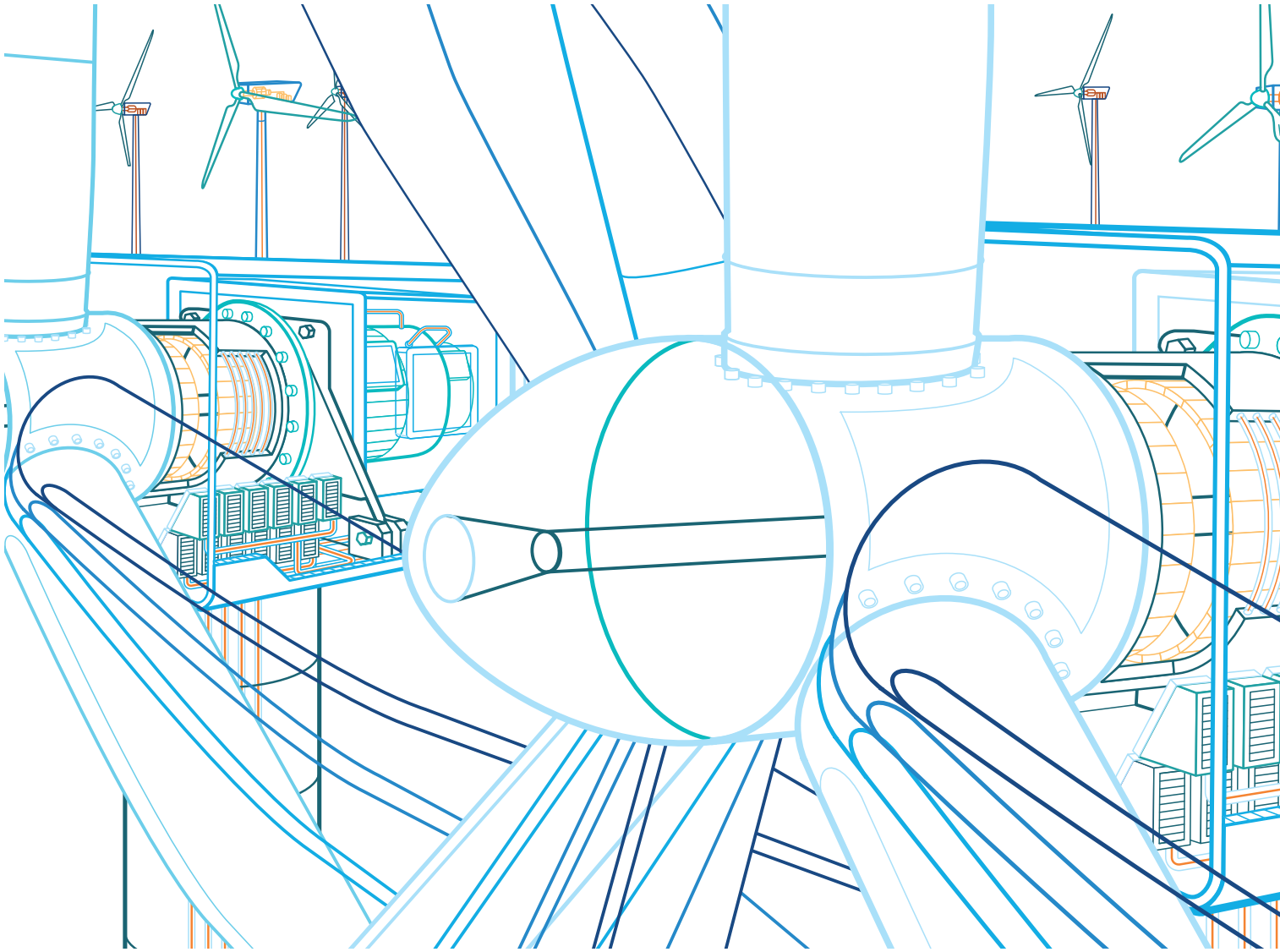

## Wind and windings. Emission-free electrical energy with ABB miniature circuit breakers.

Florian Krackhecke: *Product Marketing Manager - DIN Rail Products*

The avoidance of CO<sub>2</sub> is one of the paramount goals being targeted in this century. Worldwide, there are ambitious targets in place for this purpose: one option is increased utilization of renewable energies for generating the requisite energy. And one of the most promising energy sources available is wind energy.

ABB offers a broad assortment of low voltage products for wind turbines. Generators, converters, transformers and motors as well as low voltage circuit breakers, contactors and miniature circuit breakers complete our portfolio for wind turbines.

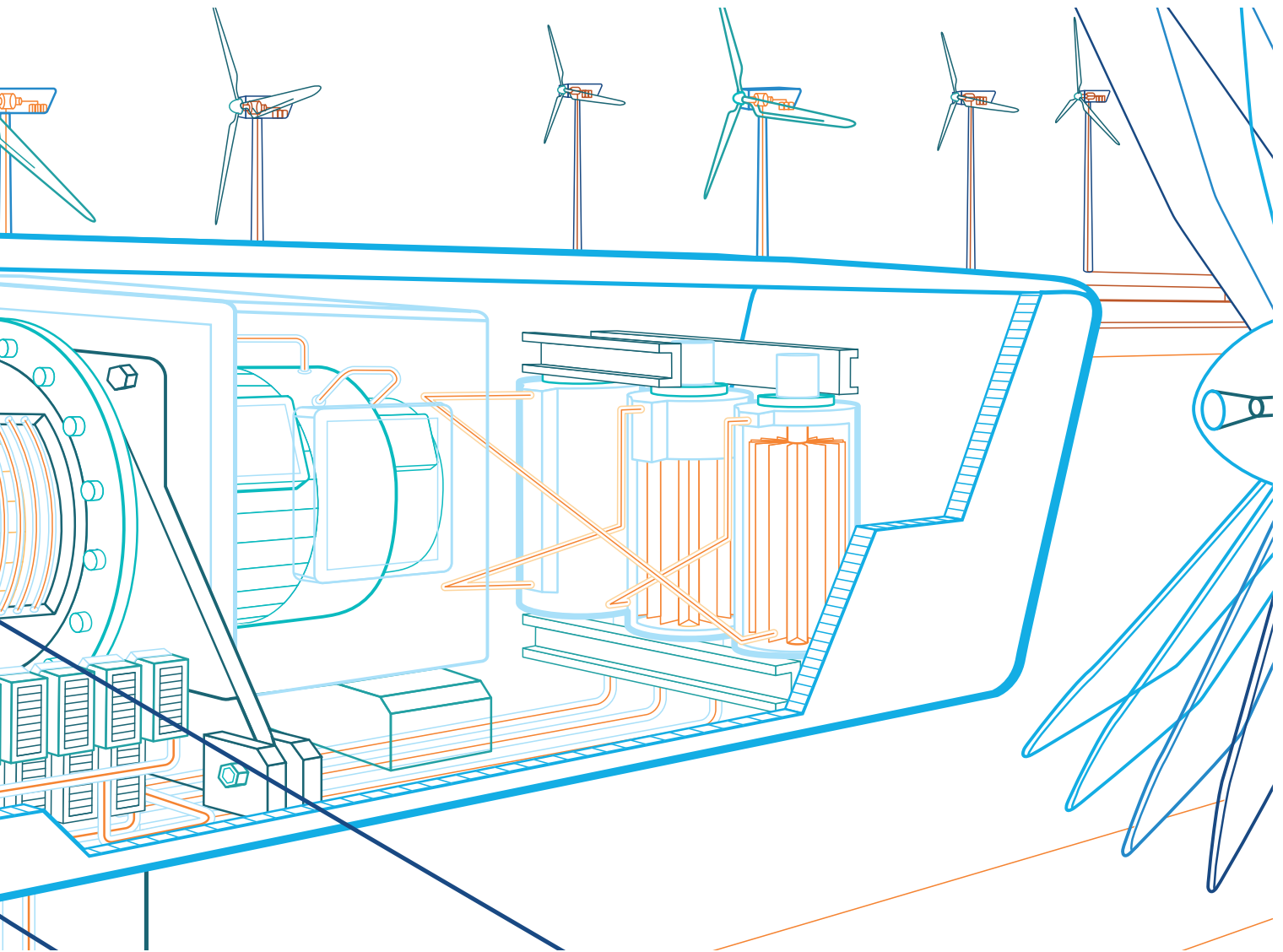

**General introduction and components of wind turbines:**

A wind turbine is composed basically from: Blades, Tower, Nacelle and Rotor or also called Hub. In picture 1 the basic parts are described:

- 1. Blades:** The blades are the mechanical part that determines the rotation of the shaft and permit the energy conversion. The rotor diameter of the blades is the function of the power generation and the average wind speed. For the number of blades it's typically and most of the time equal to 3.
- 2. Tower:** The tower supports the nacelle which may also include some control panels and generally houses at the basement the medium voltage switchgear.
- 3. Nacelle:** The nacelle provides the housing for a host of equipment located at the top of the wind turbine tower such as generator, control panel, yaw system.
- 4. Hub:** The hub of the wind turbine is the component that connects the blades to the main shaft, transmitting to it the

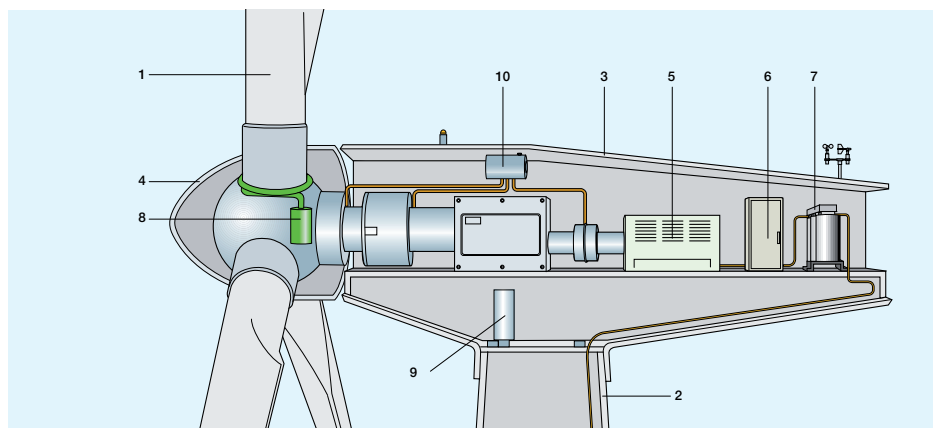

**Picture 1 - Main components of a wind turbine**

power extracted from the wind; it generally includes the pitching Systems.

Going further in the details, the schematic of the turbine in picture 1 is showing the main sub-system and components constituting in wind turbines as well.

The Electrical drive train that include: the Generator (5), the converter (6) and the transformer (7).

The transformer (7) and converter (6) can be located either in the nacelle, in the tower or in the basement according to different drive train and wind turbine design.

Then the wind turbine is formed by Blade Pitch Control System (8), Yaw system (9), and finally hydraulic cooling systems (10).



**ABB is supplying one of the leading pitch system manufacturer SSB Wind Systems**

**What is a pitch control system?**

Blade pitch control is the system which monitors and adjusts the inclination angle of the blades allowing the control of the blade rotation speed.

**And how does a pitch system work?**

When the wind speed is low, the pitch system orients the blade more perpendicular to the wind in order to increase the force on the blade and therefore accelerate the hub rotation. In contrary, when the wind speed becomes too high, the pitch system reduces the wind load on the blades to slow down the rotation.

Over a certain wind speed the blade pitch control system rotates the blades out of the wind thereby slowing and then stopping the blades to reduce the forces on the structure of the turbine and avoid complete damage.

**What are the benefits of pitch systems?**

Wind speed is not constant over the time and rapid changes of the wind puts high demands on a wind turbine dedicated electrical and mechanical design, in order to maximize power output. Pitch systems ensure the optimum control of the power output over the entire operating range of the wind turbine.

In case wind is weak the rotor blades offer their entire width to the air flow, and in the other extreme case of increasing wind speed the blade incidence angle can be reduced. Thanks to this adjustment possibility, the best operating angle can be achieved for the turbine in both strong and weak winds.

For the electrical design this results in frequent operations of the control actuators (e.g. pitch adjustment) and repeated connection and disconnection of the power circuit with fast warm up of the conducting components as a result.

The picture 2 describes the specific power output at different wind levels of stall controlled turbines (red dotted line) as well as pitch controlled turbines (blue dotted line). This is one of the advantages of pitch controlled systems.

The range of wind speed is wider for the pitch controlled systems and it allows keeping the power curve at a maximum of 100% from 15 to 25 m/s, solving the problem of the overspeed.

**What happens without blade control?**

The pitching system is used for doing start-up and shut-down operations of a wind-turbine and also regulates the braking of the turbine by using the power and efficiency of pitch systems. Such an “aerodynamic brake” is much more effective than a purely mechanical one.

As a crucial part of the braking system (emergency system), a pitch system is linked to all monitoring and safety systems of a wind turbine. Pitch systems should have a separate emergency source (battery back-up or similar) in the event of a malfunction of the normal power source or in case of emergency for example. Only in this way the pitch system can turn the blades out of the wind and slow down the rotor independently of the external grid.

If a wind turbine is not shut down quick enough, it could happen that the rotor enter into the overspeed range what could end in a burning nacelle. A second sce-

Picture 2

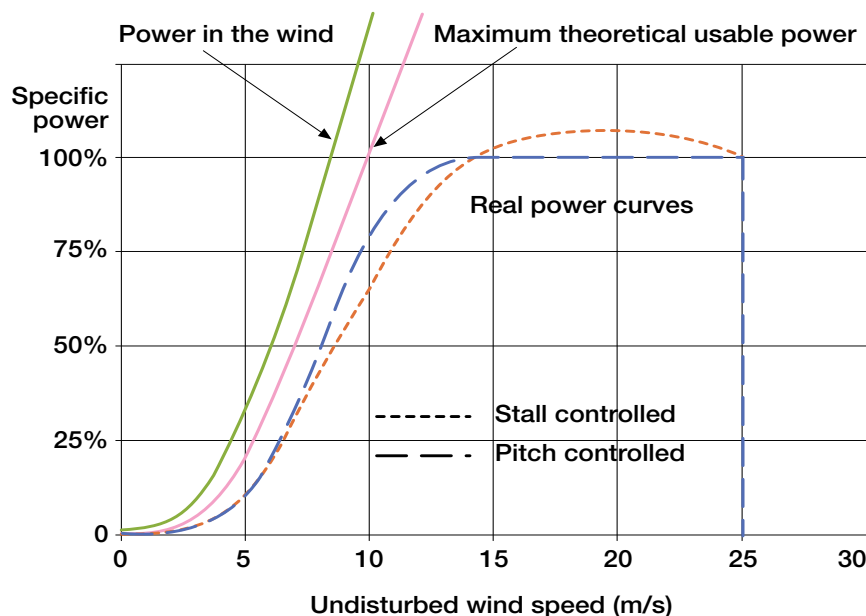



nario what could happen that the blades are stressed by the high speed that they fracture or break off entirely.

**What kind of pitch systems are available on the market?**

There are basically two types of rotor blade adjustment that are currently used: blade pitch systems with hydraulic or electric drive (also known as electric pitch system). Another possibility would be the “passive blade pitch”. However, due to lack of active control possibilities (Emergency-Stop or start-up operation) this type isn’t used at all or just very little.

Involved people said that hydraulically operated blade pitch systems are no longer part of newer wind turbines. Dealing with the hydraulic hoses and units has not proven itself in practice. Continuous leakage problems require too much maintenance which becomes even a bigger problem at off-shore turbines.

**Are different pitch system concepts available?**

Our customer SSB Wind Systems, one of the leading pitch system manufacturers, offers a wide variety of system versions to ensure that the pitch system is perfectly tailored to the needs of each individual wind turbine. This gives a complete flexibility, as well as a high level of efficiency and reliability when it comes to integrating a pitch system in a customers wind turbine – regardless of the available room or the construction type of the individual hub. The basic package of SSB Wind System is the 4-Box System. In addition, they develop system versions with 3, 6 and 7 boxes:

– 3 box system which combines axis cabinet and battery compartment in one box for each blade:

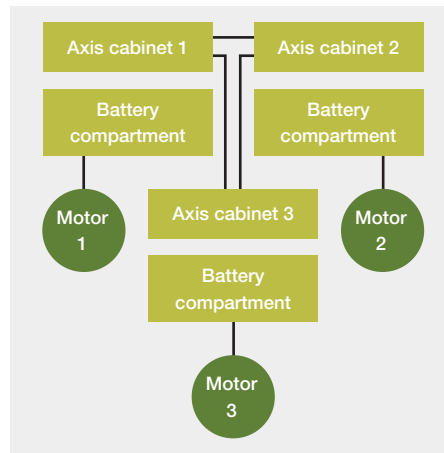

– 6 box system which separates each axis cabinet and battery cabinet for each blade:

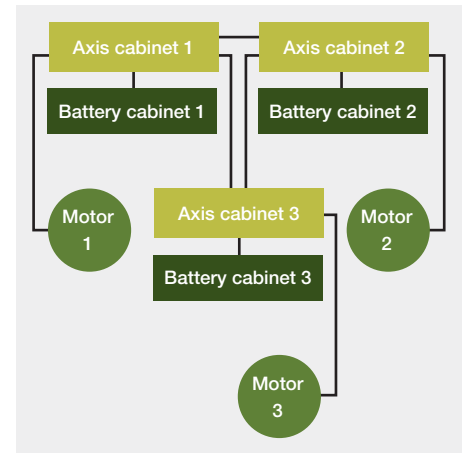

– 4 box system which combines axis cabinet and battery compartment in one box for each blade controlled by a central pitch controller cabinet:

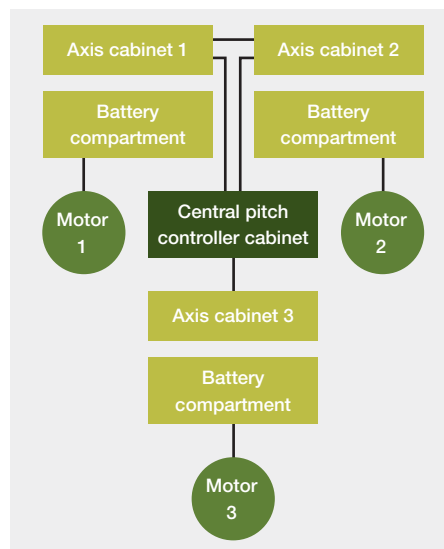

– And 7 box system which separates each axis cabinet and battery cabinet for each blade which are all controlled by a central pitch controller cabinet:

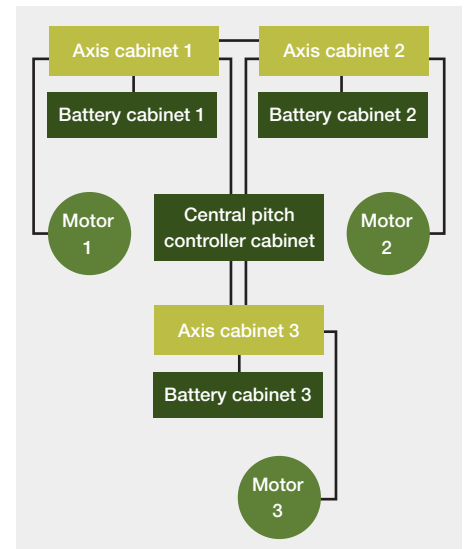

**Picture 3**  
This is a sample of an axis cabinet of a pitch system from SSB Wind Systems equipped with ABBs miniature circuit breakers.



**One of the leading pitch system manufacturers, SSB Wind Systems, trusts in ABB Low-Voltage products**

Requirements for miniature circuit breakers could be:

- Different ambient conditions according to different turbines manufacturer and place of installation
- Compact and space saving solutions
- Availability all over the world
- Signalization
- High availability and proven technology (eg ISO certified)

For what concern ambient temperature can be hot environment, where the turbine is equipped with air condition to control the temperature (especially for the electronic system like converter). In this configuration the Working temperature is typically from -5°C up to 70°C

On the other hand for cold environment the turbine is usually equipped with heaters to warm up the system in the ramp up stage. Working temperature can be from -40°C up to 50°C

ABBs miniature circuit breakers are tested and could be used in this temperature range from -40°C up to +70°C.

In the same way as temperature, you could add that typical requirement for:

- Humidity is 100% no condensation S200 MCB can full-fill
  - a) 30°C, 100% rel. hum., damp heat, steady state acc. to DIN 50015 ("Kesternich" test)
  - b) 55°C - 25°C, 90%...100% damp heat cyclic (cycle 12 + 12 hr.) acc. to IEC 60068-2-30
- A max altitude of 3000-3500m S200 MCB up 2000m without derating and ABB can provide derating datas for used up to 6000m!
- Corrosion could be class C3 according to ISO 12944-2.
- Vibration could be class MC2 according to IEC 60947-1.

Low voltage products typically comply with the ambient condition required by the customers; anyhow when the requests are out of the standard ABB support the customers delivering special products, table of derating or customized test plan.

Their main benefits of ABBs miniature circuit breakers are:

- compact solution
- rated current from 0.5 to 125A
- breaking capacity from 6 to 50kA
- international approvals (VDE, UL, CCC,...)
- proven reliability

Safety philosophy of our customer SSB Wind Systems:

- Safety has to be put to the test. Every single pitch systems is built in a way that the safety function of each axis operates fully independent of each other.
- SSB Wind Systems has, to date, successfully installed thousands of electric pitch systems throughout the world and has had many opportunities not only to test but also rely on ABB quality:
- Every single device that leaves our facilities is checked three times for quality and performance reasons. Our completely automated test methods such as thermal test, electro-magnetic test and isolation test guarantee best results and provide highest quality in daily business.

**In order to guarantee highest availability even for off-shore wind-turbines, SSB Wind Systems could rely on a proven Partner: ABB and ABBs miniature circuit breakers.**

ABBs completely automated testing environment guarantee best results and provide highest quality in daily business. Every single device that leaves our facilities is checked three times for quality and performance reasons.

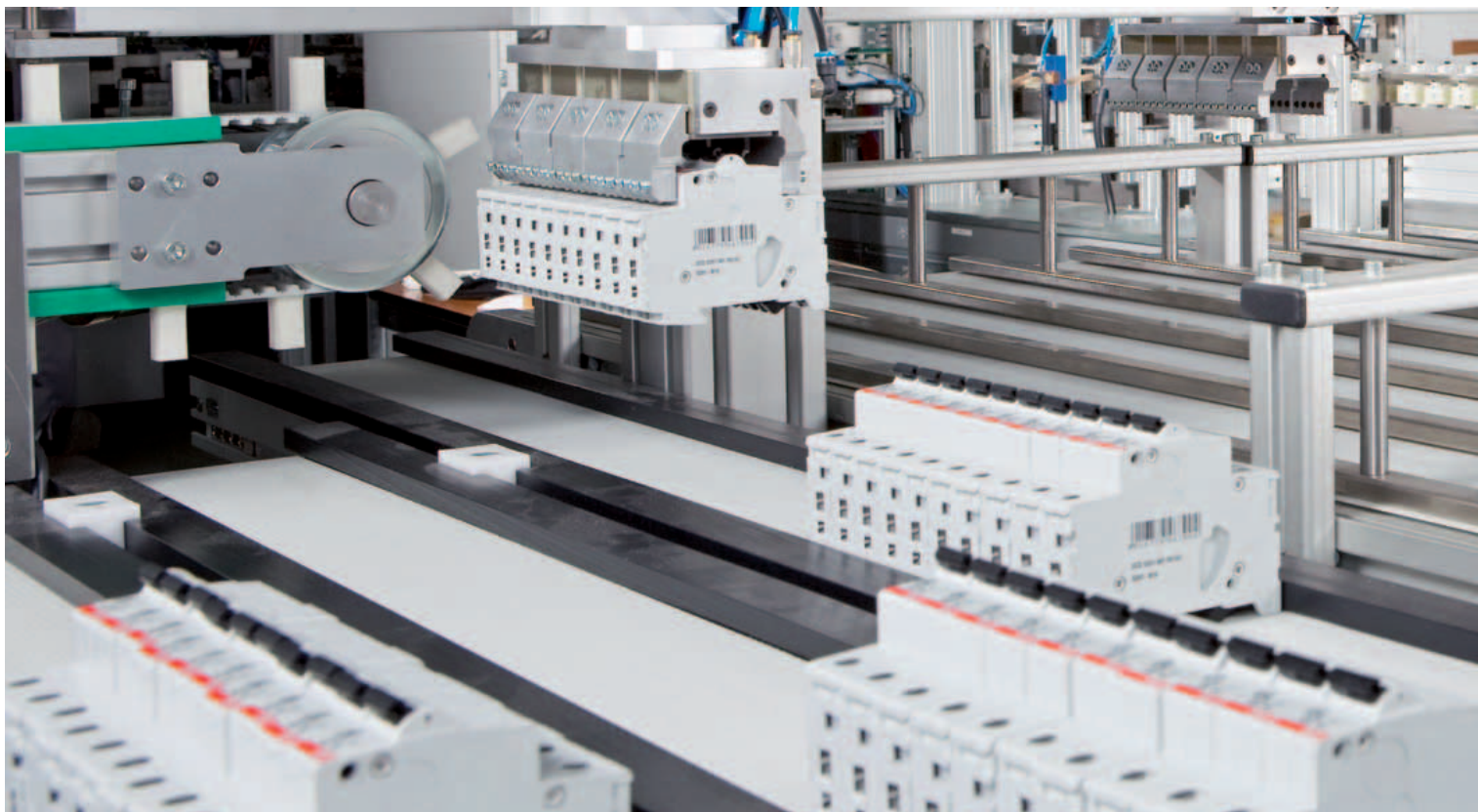



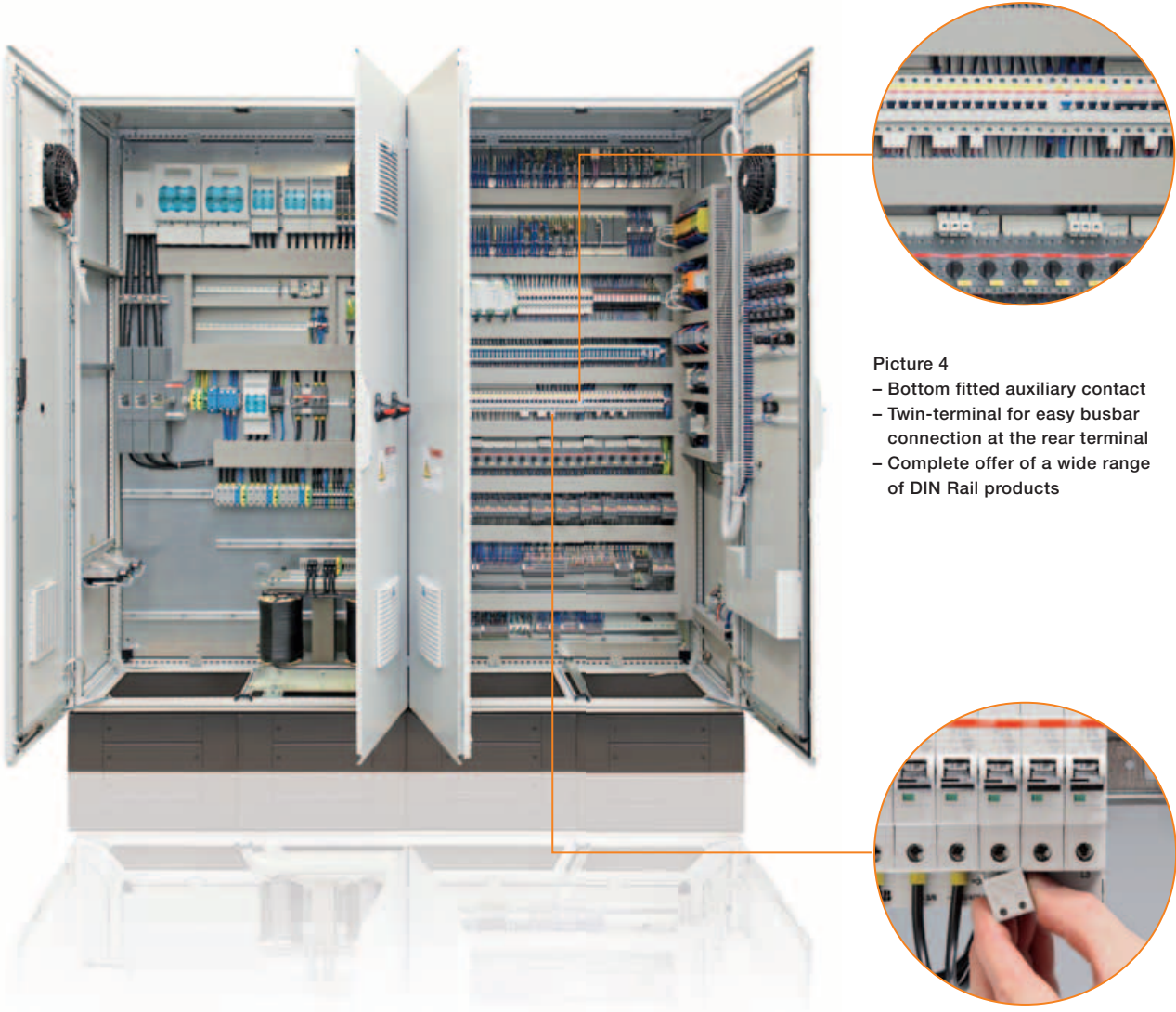

Picture 4

- Bottom fitted auxiliary contact
- Twin-terminal for easy busbar connection at the rear terminal
- Complete offer of a wide range of DIN Rail products



# Modular power distribution solution for data centres

Malving Lingwood: *Product Manager - SMISLINE*







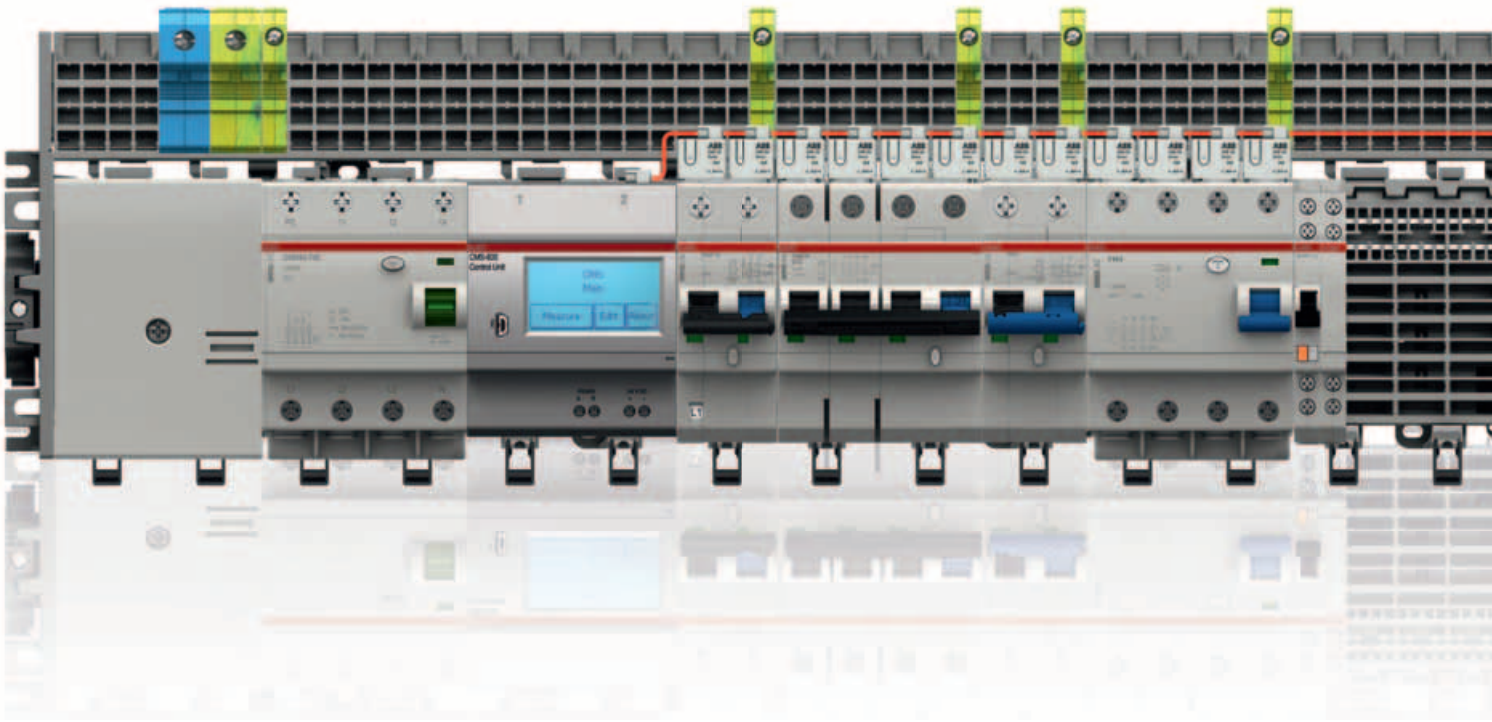

01

- 01 SMISLINE allows plug-in installation of a wide variety of devices for circuit protection, measurement and command.
- 02 Example of SMISLINE installation in a Sub Distribution Board. Vertical socket ensures optimization of space and wirings.



**Data centre solution for PDU**

In data centres the electrical power systems have to employ sophisticated requirements. The power distribution unit in a data centre (PDU) is designed to distribute electric power, especially for racks of computers and networking.

This system must contain the toughest requirements for maintenance throughout its entire life cycle. It often becomes necessary for the system to be extended or modified whilst it is live.

By employing sophisticated power often it is needed for monitoring equipment to analyze historical and real-time data. This can reduce the cost of electricity and improve its quality and reliability and enhance their troubleshooting abilities.

**Modular Power Distribution with SMISLINE TP**

The SMISLINE TP pluggable socket system is completely fingersafe (IP20B) – when devices are plugged in and unplugged, the system is always touch-proof. This means that SMISLINE TP prevents any danger to personnel from switching arcs or accidental arcing.

Components can be plugged in or unplugged load-free without any risk from electrical current running through the body. The system allows the uncomplicated, modular, flexible distribution of power up to a rated current of 200 A. Plugging in the devices quickly and without problems is essential for time-saving, cost-effective planning and execution.

**Current Measurement System (CMS)**

CMS is a system for current measurement of electrical lines. The system consists of a Control Unit and sensors with different measurement ranges (20 A, 40 A, 80 A). The sensors measure alternating, direct and mixed currents (TRMS). The sensors get connected to the Control Unit by a flat cable. You can remotely query the measurement data via a RS485 interface (modbus RTU).

**ABB solution for an intelligent Power Distribution Unit (iPDU) in Singapore**

ABB Low Voltage Systems in Singapore has secured and delivered a Data center project with all PDU fully equipped with Smissline IP20B Touch proof bus bar system and CMS current monitoring system in a MNS enclosure.

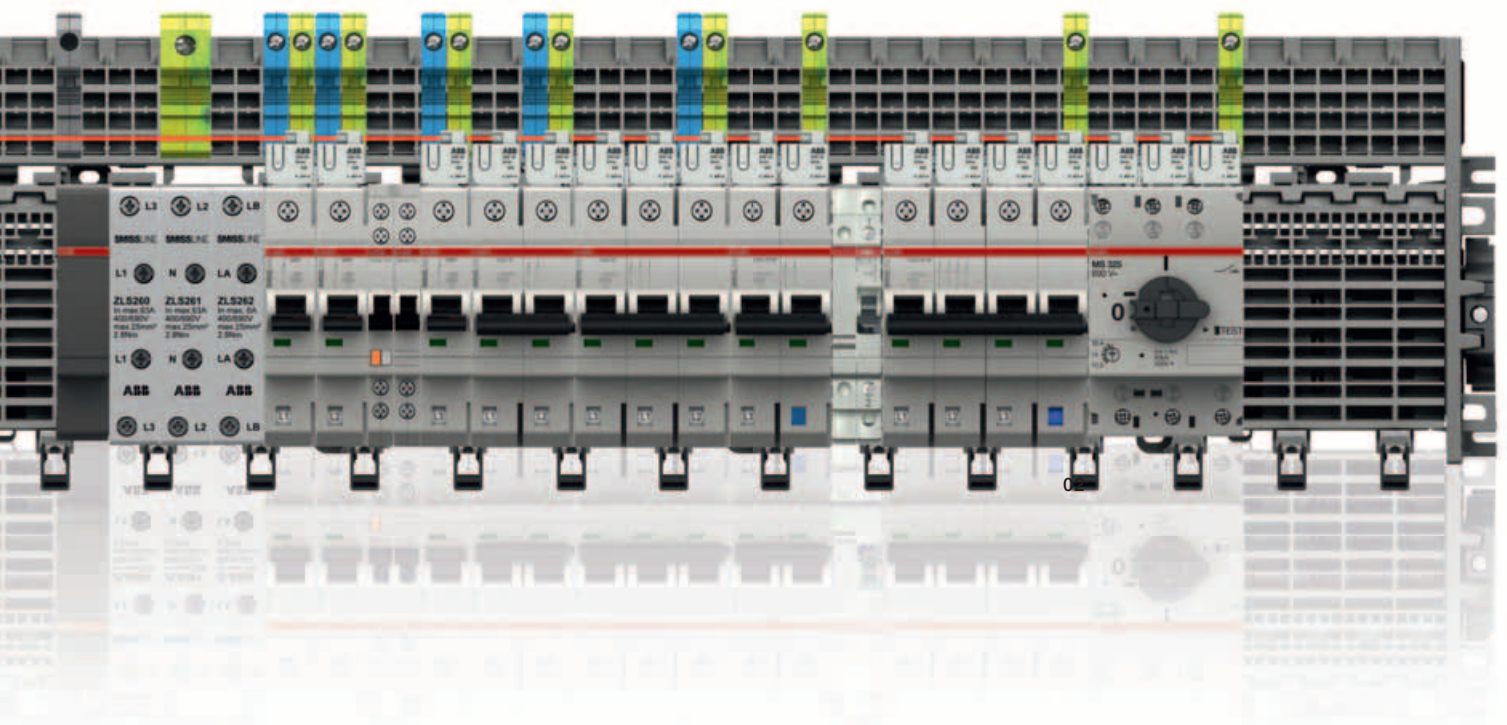

This data center in Singapore is a dedicated and premium data center. With an estimated server area of 5,000 square meters, the data center is equipped with green technologies and IPv6-ready networks. IPv6 (Internet Protocol version 6) is an internet communications protocol which allows the internet to support many more devices by greatly increasing the number of possible addresses. Purposed-built, the new data center in Singapore is positioned to take on the demands of multinational companies, in particular businesses in the financial, IT and manufacturing industries.

The PDU in this Datacenter is having a new breakthrough in term of design concept and technology used in the installation. The availability of the power is greatly enhanced by using the new touch proof Smisline bus bar and addressable digital CT technology for AC and DC current measurement. The key features for this project are:

- Ability of perform load-free protection devices under voltage without the need for additional personal protective equipment. And without shutting down the main incoming yet not compromising the safety. This is confirmed from the

German Electro association.

- Load balancing can be performed in 10 seconds without any tools, just shift the adjustable plugin pin to the desired phase.
- No wiring for Signal & Auxiliary contact, they are connected via plugin signal bus bar, no hard wiring required.
- Mixed phase installation can be easily achieved with full freedom of phase sequence and the location of the installation
- 2 meters bus bar length allowing maximizing the panel space usage (vertical mounting), 20% saving in foot print is easily achievable
- Availability of the power supply is greatly enhanced without the need to worry about the number of phases required by the load.
- CMS branch circuit current monitoring system provides AC and DC current measurement with current transformer connected with only one data bus cable that provides further saving in space and wiring.



**Malvin Lingwood**  
Product Manager  
SMISLINE

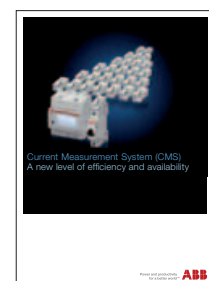

Brochure: 2CCC481002B0201





# Lightning a natural phenomenon!

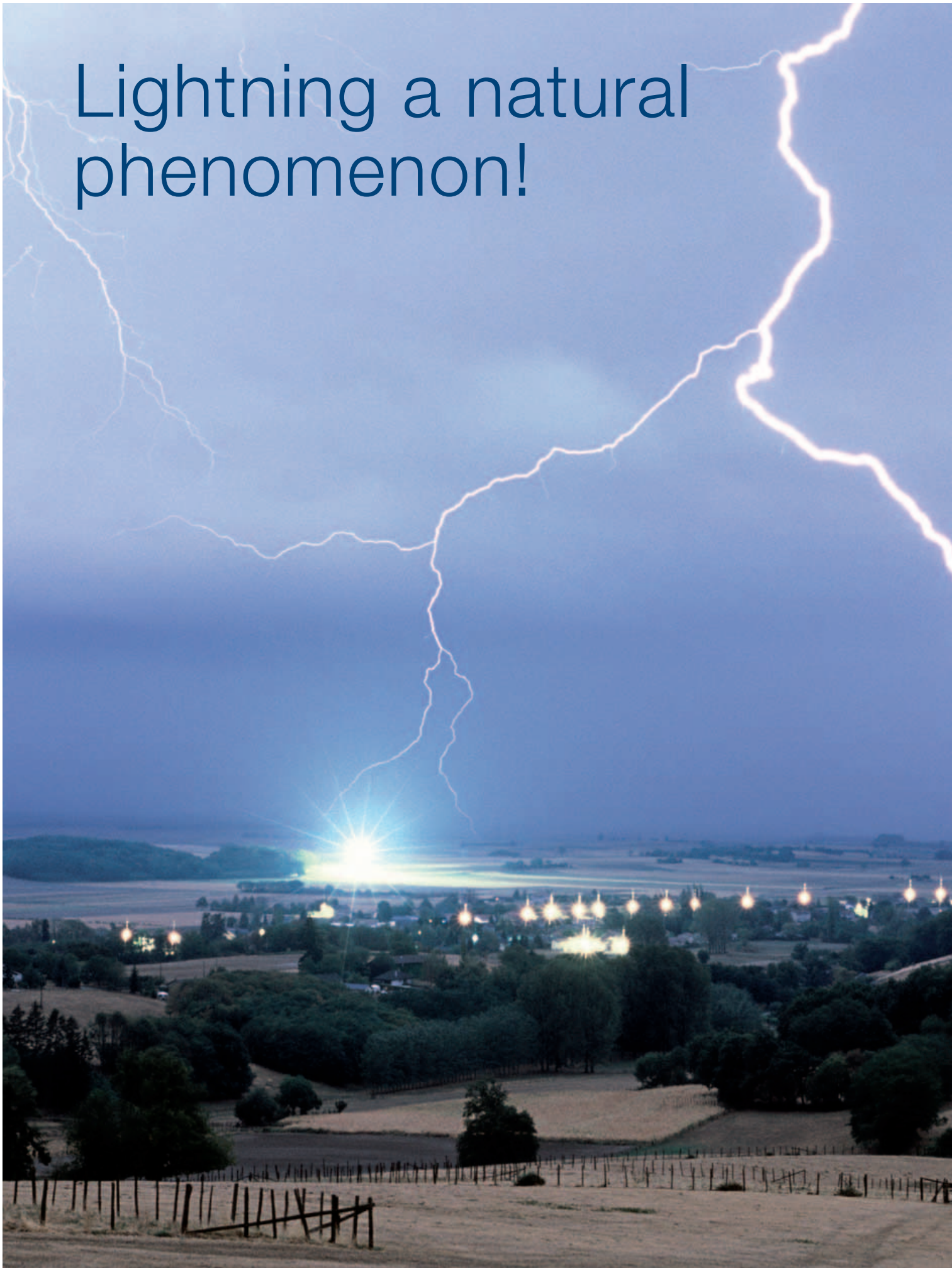





## Lightning strikes - Description of this powerful phenomenon to understand better the power of nature.

Bertrand Berges: *Product Marketing Manager - DIN Rail Products*

### Storms

The presence of unstable, moist and warm air masses gives rise to the formation of cumulo-nimbus storm clouds. This type of cloud is very extensive, both horizontally (about 10 km in diameter) and vertically (up to 15 km). Its highly characteristic shape is often compared with the profile of an anvil of which it displays the upper and lower horizontal planes. The existence of extreme temperature gradients in a cumulo-nimbus (the temperature can drop to  $-65^{\circ}\text{C}$  at the top) generates very rapid ascending air currents, and results in the electrical energisation of the water particles. In a typical storm cloud, the upper part, consisting of ice crystals, is normally positively charged, whilst the lower part, consisting of water droplets, is negatively charged. Consequently, the lower part of the cloud causes the development of electrically opposite charges (i.e. positive over the part of the ground nearby).

Thus the cumulo-nimbus formation constitutes a sort of huge plate /ground capacitor whose median distance can often reach 1 to 2 km. The atmospheric electrical field on the ground, about 600 V/m in fine weather is reversed and can reach an absolute value of 15 to 20 kV/m when a ground discharge is imminent (the lightning stroke).

Before and during the appearance of the lightning stroke, discharges can be seen both within the cloud and between clouds.

### Lightning

According to the direction in which the electrical discharge develops (downward or upward), and the polarity of the charges it develops (negative or positive), four classes of cloud-to-ground lightning stroke can be distinguished. In practice, lightning strokes of the descending and negative type are by far the most frequent: it is estimated that on plains and in our temperate zones, they account for 96% of all cloud / ground discharges.

### Mechanism of a lightning stroke

It is impossible to discern the individual phases of the lightning stroke by simple visual observation. This can only be done with high-speed cameras. Most lightning bolts exhibit the following phenomena: a leader leaves a point in the cloud and travels about 50 m at a very high speed of around 50,000 km/s. A second leader then leaves the same point, follows the previous path at comparable speed, goes beyond the final point of the first leader by an approximately identical distance, then disappears in turn. The process is repeated until the tip of the last leader reaches a point a few dozen metres, or even just a few metres above ground level.

The ascending jets then converge, producing a return stroke from the ground towards the cloud (the upward streamer) during which the electric current circulates: The convergence of these two phenomena produces the main discharge, which may be followed by a series of secondary discharges, passing unbroken along the channel ionised by the main discharge.

In an average negative lightning stroke, the maximum current is around 35,000 amperes.

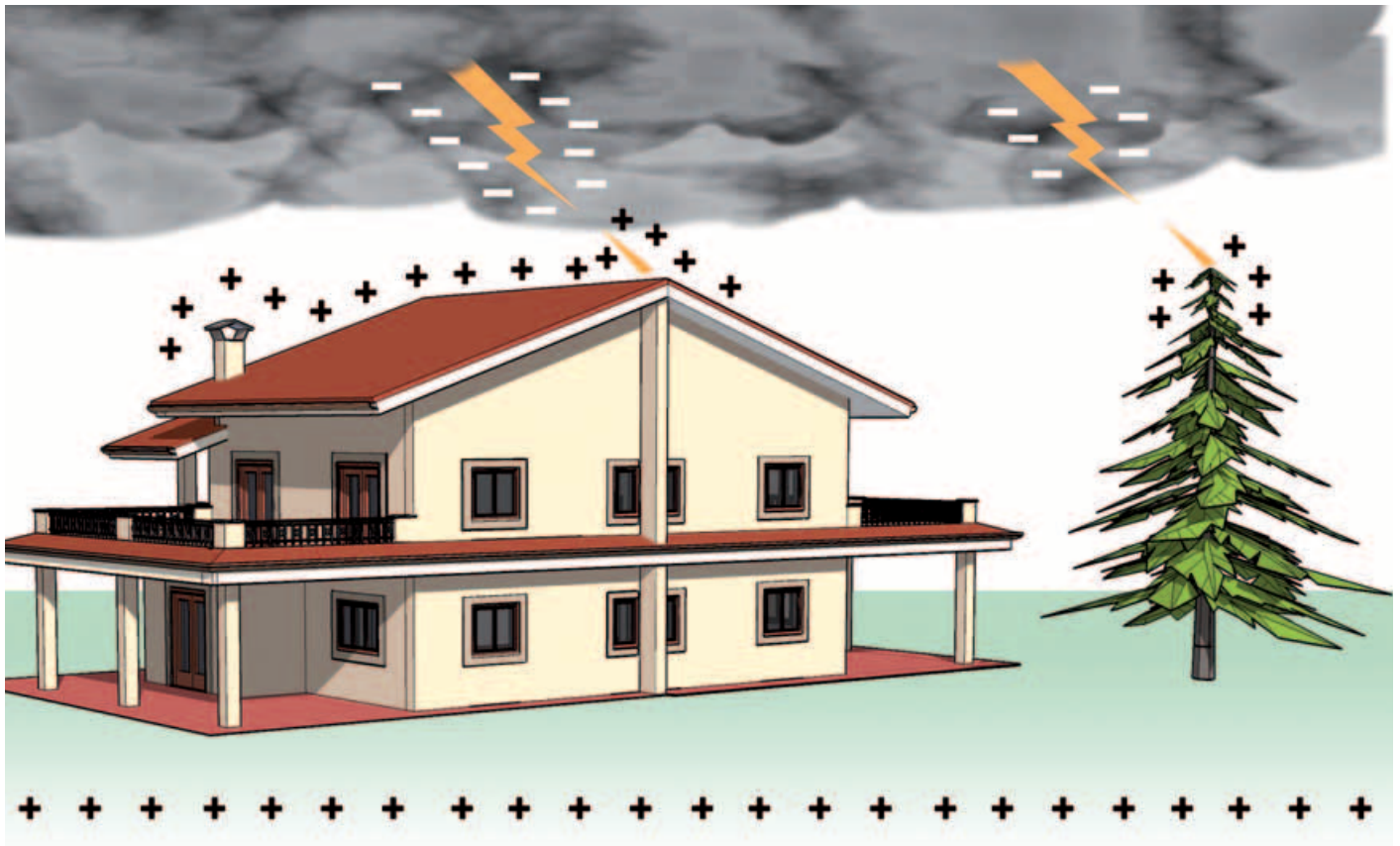

**Bertrand Berges**  
Product Marketing Manager  
DIN Rail Products

### The effects of lightning

The effects of lightning are those of a high-strength impulse current that propagates initially in a gaseous environment (the atmosphere), and then in a solid, more or less conductive medium (the ground):

- visual effects (flash): caused by the Townsend avalanche mechanism;
- acoustic effects: caused by the propagation of a shock wave (rise in pressure) originating in the discharge path; this effect is perceptible up to a range of around 10 kilometers;
- thermal effect: heat generated by the Joule effect in the ionised channel;
- electrodynamic effects: these are the mechanical forces applied to the conductors placed in a magnetic field created by the high voltage circulation. They may result in deformations;
- electrochemical effects: these relatively minor effects are conveyed in the form of electrolytic decomposition through the application of Faraday's law;
- induction effects: in a variable elec-

tromagnetic field, every conductor harnesses induced current;

- effects on a living being (human or animal): the passage of a transient current of a certain r.m.s value is sufficient to incur risks of electrocution by heart attack or respiratory failure, together with the risk of burns.

Lightning causes two major types of accidents:

- Accidents caused by a direct stroke when the lightning strikes a building or a specific zone. This can cause considerable damage, usually by fire. Protection against this danger is provided by Lightning Protection Systems (External Lightning Protection – ELP)
- Accidents caused indirectly, as when the lightning strikes or causes power surges in power cables or transmission links. Hence the need to protect with Surge Protective Devices the equipment at risk against the surge voltage and indirect currents generated.





S 200 MCB. In 1923 the first of its kind, today the best.



Back then and still today we are a trendsetting pioneer and technical leader for easy, safe and reliable use of electricity. Our circuit breakers S 200 and S 200 M are a living proof. So, with the new colored real contact position indication you can see the status within a twinkle of an eye. The optimized plane terminal plates guarantee right connection and can be reached even when the MCB is already installed. These and a lot more benefits make the miniature circuit breakers an effective addition to the successful System pro M compact®. Here you can find a wide range of compatible components for all your installation needs.

[www.abb.com/lowvoltage](http://www.abb.com/lowvoltage)

Power and productivity  
for a better world™



# Global lightning protection in France

## Offering services as a way to differentiate

Gael Grenat: *Product Marketing Manager Lightning protection and MDRCs*

In France, the lightning strikes the ground more than 2 million times a year: the best way to limit material and financial losses is to protect the structure of strategic buildings against this lightning risk without forgetting the sensitive electrical equipment inside. By the end of 2012, ABB France orders of direct protection devices went up by +47%, mainly thanks to a new regulation (Environmental Decree of July 19, 2011) including a +64% increase for invoiced services like Risk Analysis and Technical Studies. Most of the projects are still in progress, like for example the protection of two hospitals in Paris and Bordeaux, one Nexity building and one Philips site in the Parisian area, two Calcia cement factories in the South-East, and several substations abroad for Alstom Grid. Each project having a value from 15,000 € up to +50,000 €.

This is also the reason why R.T.E., the company managing the French power supply network, decided to implement a global protection against lightning for its national training center located in the Eastern side of Lyon, a project allocated to INEO group for the installation part. Complying with the new High Environmental Quality HQE® standard, the construction of the building started in 2011 and ended in 2012 for a global investment of 18 million €. The roof of the 6,200 m<sup>2</sup> building is covered by more than 30 photovoltaic panels to be self-sufficient for supplying hot water.

To help the 2,500 trainees expected per year manipulating electrical installations, the R.T.E. training center is using new green and safety technologies, like for example a transformation substation.

For the site director, the protection of the building against direct lightning and transient overvoltages was a must: “In our activity, we could not take the risk to face to an interruption of the power supply or a destruction of sensitive electronic components”. The training center is in fact located in an area subjected to frequent lightning strikes, and is isolated with no other building around increasing a lot the lightning risk.

In collaboration with a local installer, Acroterre Vertige, specialized in all work at height, the dedicated French ABB team has offered a +25,000 € full solution to RTE, managing the Risk Analysis and Technical Study, delivering products and moving on. To protect the structure of the building itself, an Early Streamer Emission Air Terminal (ESEAT) ABB PULSAR RodCheck® - made in the South-West of France - has been fixed on the top of the roof, and is able to generate an upward leader to capture the lightning, and divert it to the earth through a 160 meters long down conductor. This stainless steel lightning arrester is energy self-sufficient since it takes its service power from the ambient magnetic field existing during a storm, and indicates the lightning capture with the mechanical RodCheck® moving ring.

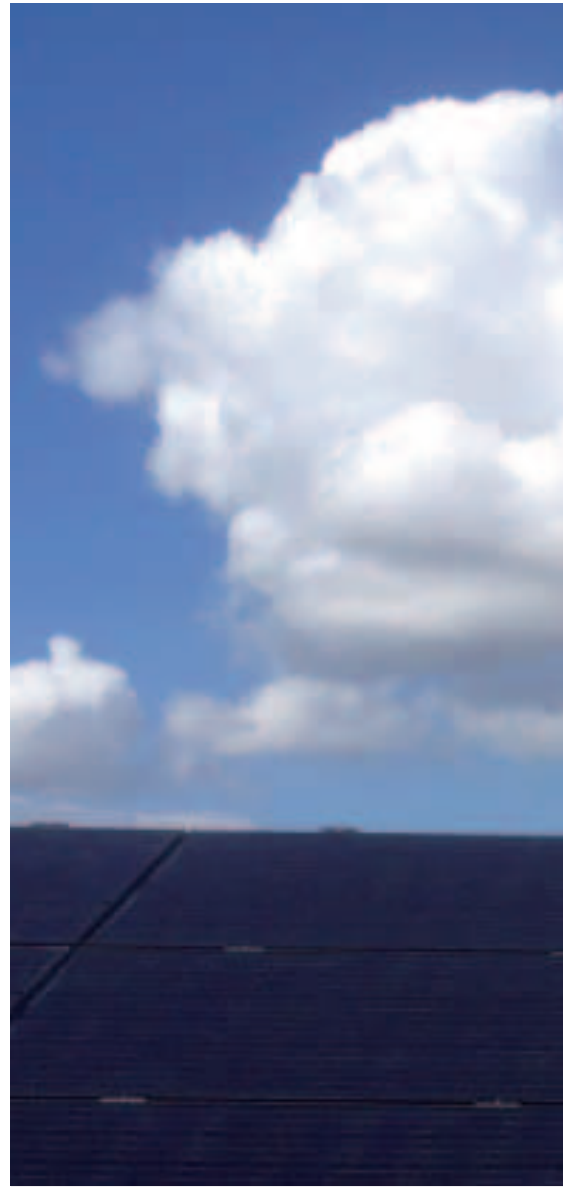



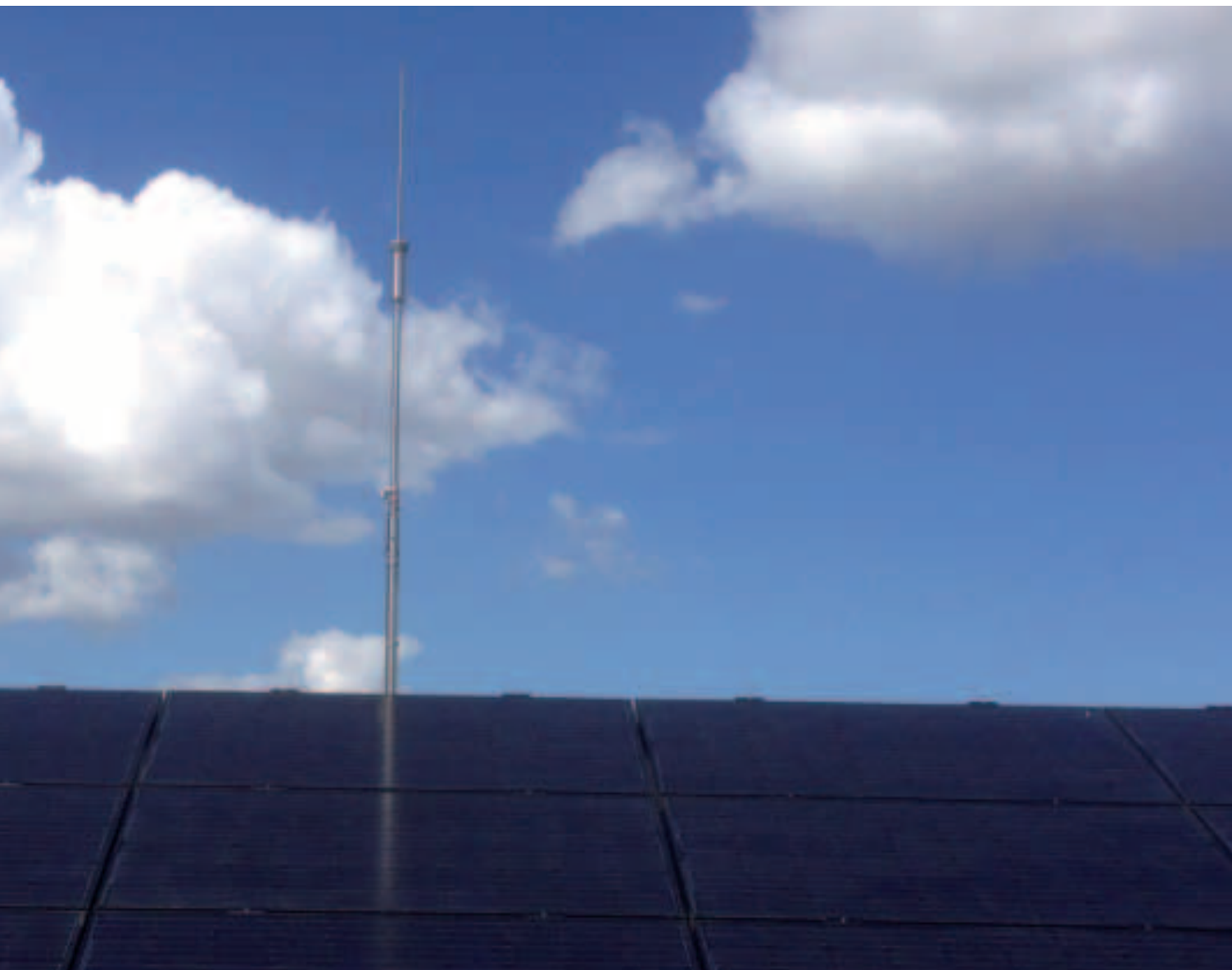

To protect the electrical installation, an ABB OVR Type 1 surge protective device (SPD) has been installed in the main distribution board of the low voltage system network, and an OVR Type 2 SPD in the sub-distribution board close to the sensitive electrical equipment to protect. An OVR TC SPD was also installed to protect the telecommunication lines.

Why did the ABB team get the project? “Actually lightning protection is a very particular activity, and I needed to be advised by a specialist. I found a solid know-how through the ABB team and I was reassured because ABB masters the manufacturing of both ranges”, said the INEO project manager in charge of the installation of the equipment. In addition to the products, the global approach and the professional service offered by the ABB lightning brings re-activity with a quick decision -making process.

As explained by Marc Gelin, Sales Director of the lightning and surge protection activity within ABB France, “the specific lightning team is a way for ABB France to differentiate against non-specialized competitors which don’t have this know-how. During a meeting with a customer, talking about the surge and lightning protection is a good way for starting the dialog and bringing interest”. It should be noted that the ABB lightning protection team is dealing with residential, commercial building and industrial sectors, and specific markets like photovoltaic energy or water treatment installations.



**Gaël Grenat**  
Product Marketing Manager  
Lightning protection and MDRCs

# ABB Smart Lab

ABB is proud to present the new Smart Lab, dedicated to study and simulation of Smart Grid components and systems.

*Enrico Ragaini: Cyber Security Manager - Low Voltage Products Division*



**F**irst, let's say what a Smart Grid is: it's the future evolution of the power distribution system, in which components will exchange data and information in addition to energy. This will make the grid able to adapt to the presence of new, distributed sources of energy, such as solar and wind.

Current distribution networks are mostly designed in a radial configuration, where power is drawn from the high voltage transmission networks and supplied to the end users, with a unidirectional power flow. On the other hand, distributed generation causes the energy flow to become bidirectional, e.g. power flows from the photo-

voltaic panels into the grid. Furthermore, direction of the flow may change with time, according to energy usage and weather conditions. These fluctuations make it impossible to manage the grid in a traditional way. Utilities and network operators need to be informed all the time about how much power is coming from where, and how voltage and other electrical quantities are affected. Measurement and communication will be required throughout the power system. A constant, ubiquitous data stream will flow along the grid together with power: the result will be what we call a Smart Grid.



A live view of such a grid is available in the Smart Lab in Dalmine, where a medium and low voltage electric distribution network has been built, with real components and devices, including medium voltage/low voltage substations with connected loads and generators.

Thanks to the real-time simulation engine, studied and prepared in collaboration with the Polytechnic of Milan, normal operation conditions and faults in different sections of the network lines can be simulated. Different protection settings and operation strategies can be applied, and the effect on the grid is immediately visible. This allows to represent a wide range of network setups, from those currently deployed to the high-reliability, redundant

configurations that will be used in future applications.

The full portfolio of ABB Low and Medium Voltage Products and Power Systems is installed in the Smart Grid Lab: Medium Voltage and Low Voltage switchgear, protection relays, circuit breakers and measurement and control devices. Communication interconnects all components to each other and to the supervision system. The protocol used is IEC61850, the international standard for electrical system automation. Station-to-station wired and wireless communication channels are also implemented.

The Smart Grid Lab is of course available to show during customer visits. We look forward to your requests.

# New design for an overcurrent tripping unit independent from the ambient temperature

Stefan Valdemarsson: *Corporate Research*

Marley Becerra: *Corporate Research*

Henrik Breder: *Corporate Research*

Joachim Becker: *Product Manager - DIN Rail Products*

## Basic functions of a MCB

It is very important to interrupt an electric circuit when a short-circuit or an overload condition occurs. The combination of a delayed overcurrent trip and an instantaneous short-circuit trip make the MCB to an excellent protective device. Today's Miniature Circuit Breaker consists of the following main basic functional components: a bimetal overload trip, an electromagnetic release for short-circuit trip, a switching mechanism with contacts and an arc extinguishing system. Picture 1 shows the basic components.

In this article we concentrate on the overcurrent tripping device. The essential part of the thermal overcurrent trip is a bimetal strip, which consists of two different metals rolled together. Due to the dif-

ferent expansion coefficients of the metals the bimetal strip deflects when heated, for instance by an electric current. The deflection depends on the heat which is corresponding to the height and duration of the electric current. Depending on the electric current and the tripping characteristic the bimetal activates the switching mechanism accordingly and the MCB switch off.

As described above the bimetal reacts on heating. Up to this performance it senses both the heat from the line current and the temperature inside the apparatus which is a function of the ambient temperature of the device. Consequently the MCB trips at lower current when the ambient temperature is increased and at higher current when the ambient temperature is decreased.

01 Basic functional components of a MCB

02 Tripping device:  
A) basic operation,  
B) schematic of rotor and stator

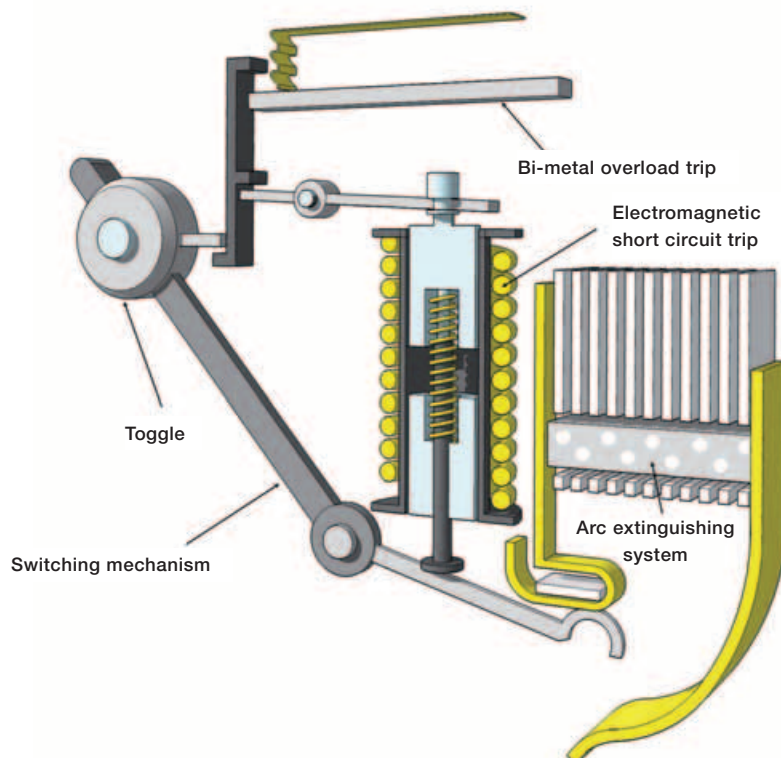



**Special requirements**

For special applications, e.g. battery supplied DC systems, it is necessary to supply the system with the rated current in a wide temperature range. Due to special fault tolerant states and redundant operation concepts the overcurrent protection needs to work independent from the ambient temperature. During normal operation the system is cooled by the internal cooling system. In many systems a shut-down of the internal cooling system or climate control failure is classified as "normal state" including fault tolerant operation. The time to repair could be more than five hours and the temperature inside the switchboard could reach up to 70°C. The time of five hours is longer than

the time constant of the bimetal and consequently the MCB would trip below the rated current. This affects the reliability of the system.

To eliminate these disadvantages the Corporate Research Center in Västerås, Sweden, developed a temperature independent tripping device.

**Basic principle of the new device**

The new overload tripping device is based on the rotation of an electromagnetically damped rotor in a magnetic circuit where the driving magnetic field  $B$  is created by the fault current (picture 2). When the current exceeds a certain value defined as overcurrent, the rotor rotation (with an angle  $< 360$  deg, typically

90 deg) moves the latch of the device. The movement of the rotor is transferred to the latch through an excenter or ramp on the rotor shaft. When the rotor movement has completed a pre-set angle and the latch is released the switching mechanism opens the contact system and the current interrupts.

The rotor of the new overload tripping device is formed by a cylindrical permanent magnet (PM) with diametrical pole arrangement. An air gap allows the free movement of the rotor. The stator is a core of soft magnetic high permeable material with slots to control the flux in the magnetic circuit. The stator also holds the winding through which the fault current flows and creates the magnetic field that drives the

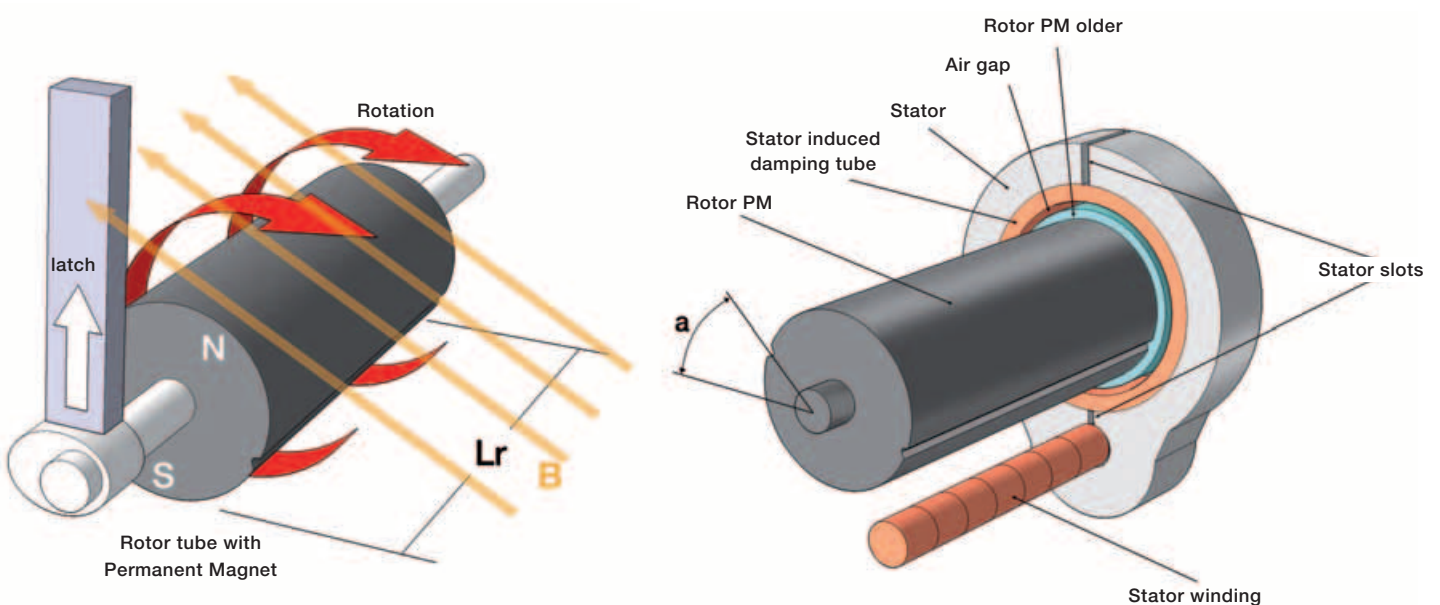

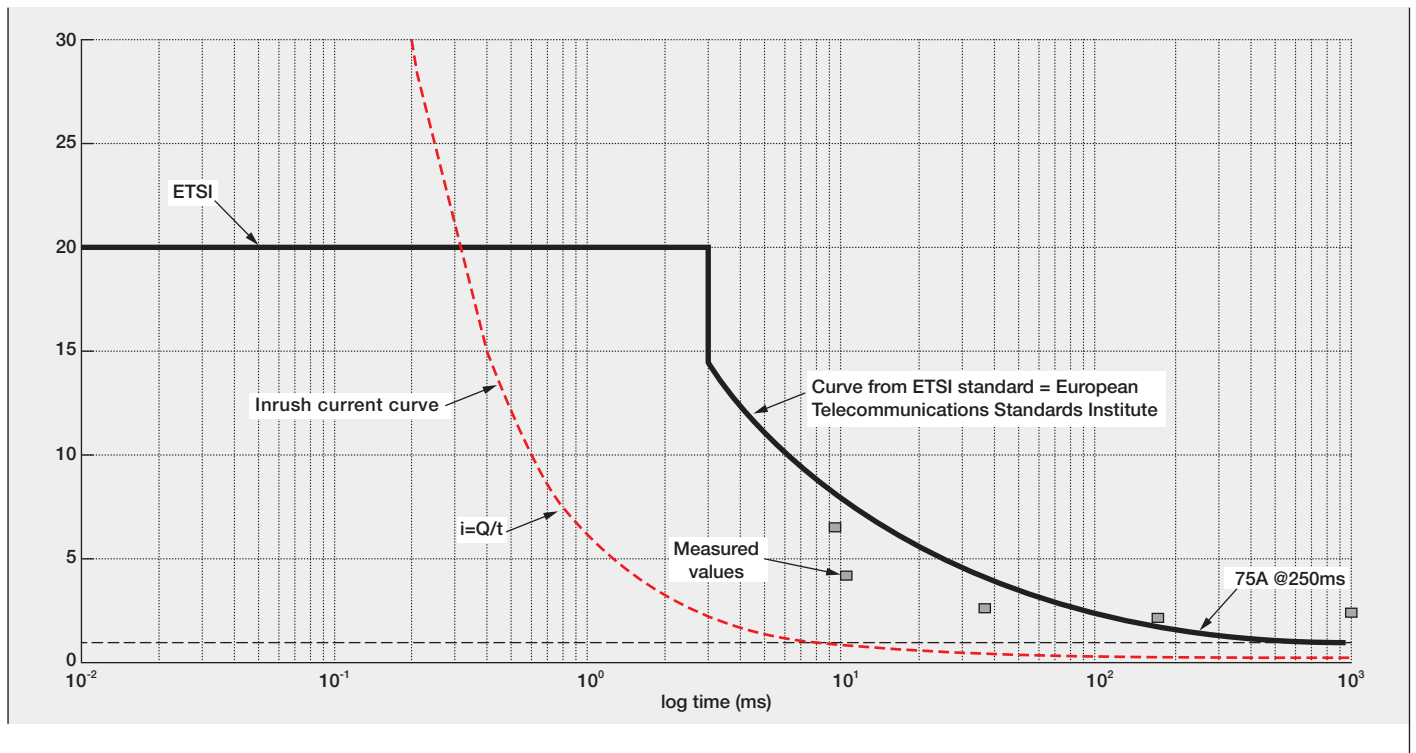

03 Tripping diagram

rotor rotation. In order to provide a damping effect for the rotor rotation, a copper tube is introduced between the rotor and the stator. Such effect is required to set the response of the tripping mechanism in compliance with the time invert trip curve. In addition, a spring is added to the rotor shaft to bring the rotor back to its initial position after operation. The force of the spring is the main mechanical counterforce to the driving force provided by the fault current. Thus, it is only when the current exceeds the pre-adjusted overcurrent value that the driving force overcomes the spring counter force and starts to rotate. As the rotor angular velocity increases, Eddy currents are induced and produce the damping force, which, together with the rotor's moment of inertia, determines the time required to complete the rotation to the tripping angle.

A prototype of the device was built and tested at ABB STOTZ-KONTAKT. Picture 3 shows the tripping diagram with measured values.

As one of the possible applications are telecommunication systems a prototype was tested according to the requirements of the ETSI standard for power supply interface at the input to telecommunication equipment. The bold unbroken line shows the tripping characteristic according to the standard. The red broken line shows the inrush current curve. The MCB must withstand these values without tripping. The dots show the measured tripping values with a prototype with a rated current of 63A.

**Summary**

The new design of an ambient temperature independent overload tripping device was presented. First prototypes were tested at ABB STOTZ-KONTAKT. The experiments show that an overcurrent tripping device independent from the ambient temperature can be realized by using an assembly with electromagnetically damped rotor in a magnetic circuit where the driving magnetic field B is created by the fault current.



OVR PV. Excellent performances in maximum safety.  
Always.



Born from the experience of ABB, the first to launch them on a market which continues to choose them, OVR PV photovoltaic SPD ensure absolute protection in the photovoltaic systems. OVR PV SPDs are equipped with a patented thermal disconnecter, with d.c. short circuit interruption performances, specifically designed in order to prevent the risks of overheating and fires in photovoltaic systems up to 1000 V. Thanks to this innovative technology, OVR PV SPDs are self-protected from the end of life short circuit up to 100 d.c without the necessity of back up protection. This performance is guaranteed by the conformity to the UTE C61-740-51 guide.

[www.abb.com/lowvoltage](http://www.abb.com/lowvoltage)

Power and productivity  
for a better world™



# DINgreen

New green packaging for the DS201-DS202C RCBOs.  
Compact, ecological and convenient:  
protects the environment as well as the product!

**An ecological double-play has arrived! 100% recyclable single and multiple packaging. An ever simpler and more ecological offering for product packaging, a step forward towards sustainability!**

### Better protection than ever!

The DS201-DS202C series of RCBOs has been developed to ensure a complete protection in the different types of circuits in modern installations. Specifically, the DS201-DS202C series combines overcurrent and earth-fault protection in a single device.

### New single packaging

#### *Recycling made easier!*

The innovative single packaging box is made from 100% recycled cardboard, with fold-and-slot assembly. This assembly technique means that no glue is needed, making it the ideal solution for speeding up subsequent disposal and recycling. The new single, ecological packaging, being simple to open and flatten, also allows space to be saved in recycle bins.

#### *Saving the environment by using less paper, together!*

The instruction manual becomes an integral part of the packaging: useful information, usually contained in a separate booklet, is summarised, made easier to read and printed inside the packaging, in order to further reduce paper consumption.

### A further guarantee for all!

Finally, in order to guarantee the quality of its products and increase transparency, ABB has incorporated a new quality seal, with an external label which is broken when the box is opened.

### New multiple packaging

Now, the multiple packaging of the DS201-DS202C range has become even more convenient and easier to dispose of! Made with 100% recyclable plastic film and no glue, it contains five RCBOs, protecting them from the external environment. Manageable and transparent, it allows you to check the product quantity at a glance. The quick opening (with a red strip) shows clearly and unmistakably when the package has been opened. Moreover, the label of the multiple package is removed when it is opened, avoiding it being confused with single pack labels. Finally, disposal is very easy: just ball it up and place it in the plastic recycling bin. Simple, ecological and convenient, innovation is now even more sustainable!





# From electrician to marketer! - The five “W”s

Federico Mai: *Marketing Communication Account - LP Division*

Products, technical specifications, performance, functions and examples of applications are all essential knowledge for electrical installers. It is, however, equally clear that in an ever-more competitive market such as today's, it is more important than ever to acquire skills in non-technical fields in order to differentiate yourself from competitors and thus increase turnover. For this reason, you will find a small list of tips in this section which we think will help you to better understand marketing and communications theory and practice and apply them to your work. These things often make the difference when approaching a customer (as services, products and prices offered are often very similar), stimulating the creation of new ideas and solutions or simply helping get past the questions “Where do we start?” or “How do we do this?”.

## The 5 W's rule, or how to avoid “blank page syndrome”

The Five W's rule is the golden rule of journalistic style in the English-speaking world.

The 5 W's are:

- WHO
- WHAT
- WHEN
- WHERE
- WHY

The 5 W's must be considered essential points which must be present in the lead of an article as he is the answers to the questions which the reader will certainly ask as he is reading it.



The rule is therefore a reminder which facilitates gathering ideas and ensures essential information is not forgotten. It is proving to be even more useful and relevant above all with new media, when concise information is sent quickly in an e-mail, SMS or tweet, or when the psychological block known as “blank page syndrome” sets in.

Clearly, depending on the situation, other information can be added or that which is not essential or relevant can be removed. For example, when describing an event, we are generally answering the question HOW; on the other hand, in a crime story, saying WHY is mainly the job of the police, and the journalist will report this at a later date, if and when the investigation has been successful.

The usefulness of this rule is therefore the ability to summarise the important information as much as possible in a concise and pithy manner; longer texts can use it as an outline to be followed when creating the document. In a school environment, for example, it is not uncommon for teachers to recommend their pupils start with this simple information when writing their essays.

The 5 W's rule was invented in the United States in the 19th century, probably due to two factors: the size of the country and the invention of the telegraph.

Even back then there were local and national newspapers; as the latter had to report news from all around the country, relying on ordinary mail would have meant only being able to publish stories a week or so after they happened.

The telegraph was therefore a necessary and essential tool for a national daily, but the cost of the service was very high at first. As telegrams were charged by the word, people quickly learned to save on the length of messages. Correspondents learned to report the news in very little space, communicating only the most important things.

The 5 W's rule could also work as a check in the beginning: if a message contained the answers to the 5 W's, it could be sent to the newspaper or magazine.

# Connect the boxes

## Train your brain

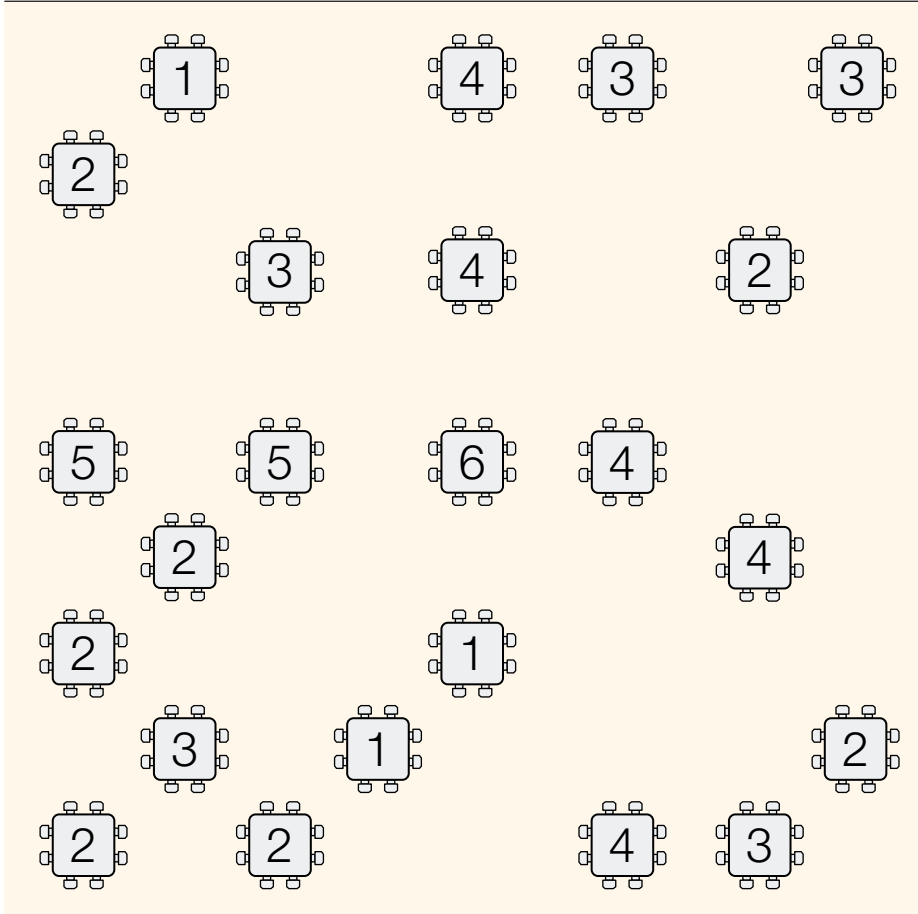

### Task

You must complete an electrical system by connecting junction boxes with cable conduits.

An electrician has already installed all the junction boxes on the wall and laid down the required connections, but then he left the job unfinished without explanation.

Your task is therefore to connect all of the boxes indicated.

### Instructions

- Each box must be connected to the others and the number of connections must correspond to that indicated on the box.
- Two different boxes can be connected with each other, but without exceeding two connections.
- Connections can be made either horizontally or vertically. Cross-connections are not allowed.
- There is only one correct solution and can be found purely by logical reasoning. No specific technical skills are required.

## You can tell a country by its socket

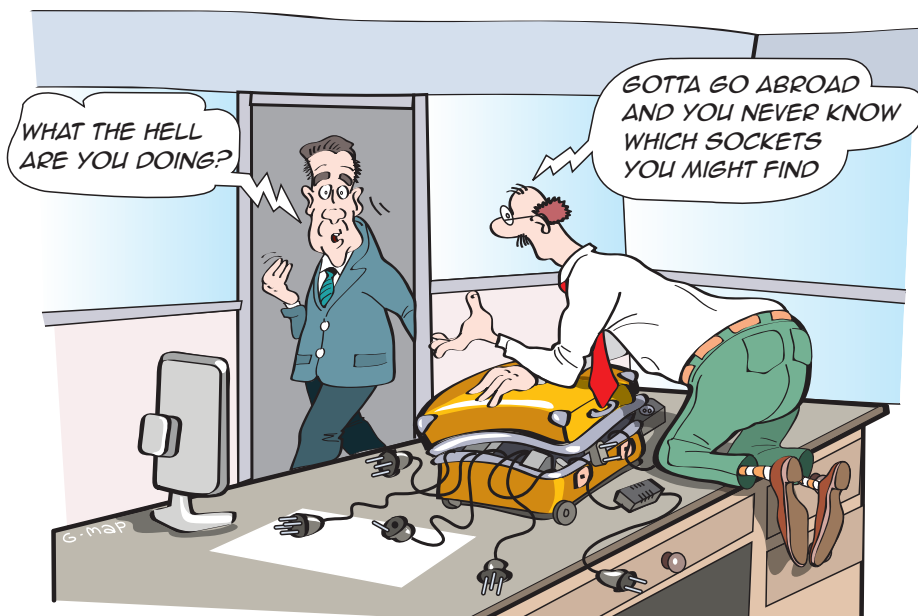

The solutions to Connect the boxes

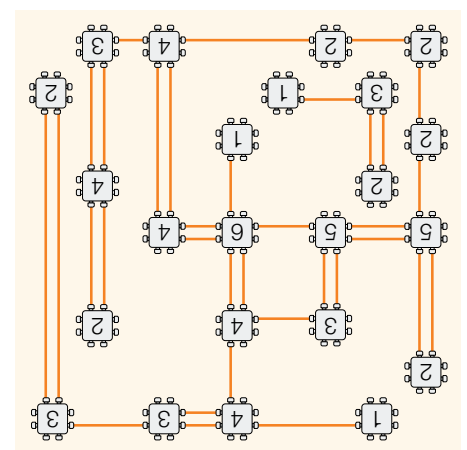



Taking sub-metering to the next level?

Absolutely.



ABB's MID-approved EQ meters offer the same quality as revenue meters, approved meters and verified meters. EQ meters are certified and have verified meter accuracy, which is a critical factor in establishing fairness in cost allocation and distribution among tenants. Many EQ meters are also delivered directly from our factory with first time verification. ABB's EQ meters are high-performance, modular DIN rail-mounted electricity meters that are safe, easy to install and can be integrated with existing and future electrical installations. EQ meters are designed to fulfill any type of sub-metering requirement. [www.abb.com/lowvoltage](http://www.abb.com/lowvoltage)

Power and productivity  
for a better world™







## CMS Current Measurement System. A new level of efficiency and availability.

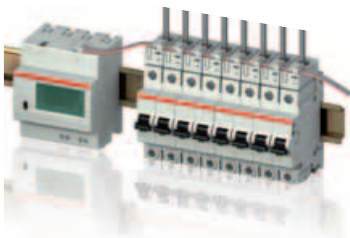

To minimize energy and downtime costs, CMS offers an unique and highly efficient branch monitoring solution. The ultra-compact CMS sensors can be easily integrated in existing and new installations within power distribution units. This provides an unprecedented transparency of the consumption which increases the energy efficiency and service continuity of the plants. [www.abb.com/lowvoltage](http://www.abb.com/lowvoltage)