

# Softstarters

Type PSS

Type PST/PSTB - New range

*New*

Catalogue 1SFC132001C0201, March 2003



1SFC13201 6F0201

**ABB**



**Industrial<sup>IT</sup>**  
enabled™

## Control<sup>IT</sup> Softstarters

### Automation Technologies

The Automation Technologies division serves customers in the automotive, chemicals, consumer, electronics, life sciences, manufacturing, marine, metals, minerals, paper, petroleum, turbocharging and utility industries.

Besides strong domain knowledge of the industries we serve, our offer includes Industrial IT-based measurement, control, instrumentation, drives, motors, power electronics, robots, software and a broad range of low-voltage products. Much of this is sold through external channel partners such as distributors, system integrators, contractors and original equipment manufacturers.

### Industrial<sup>IT</sup> for Softstarters

Due to ABB's broad program of product standardization, today Industrial<sup>IT</sup> components are the 'building blocks' of larger solutions, incorporating functionalities that will allow seamless integration in real-time automation and information systems.

At the product level, ABB's Industrial<sup>IT</sup> enabled symbol ensures that all the products can operate together perfectly. All product information pertaining to these products is available in electronic format, based on Aspect Object™ technology. The Industrial<sup>IT</sup> commitment from ABB ensures that every product is equipped with the tools necessary to install, operate and maintain it efficiently throughout the product life cycle.

ABB's Softstarters are Industrial<sup>IT</sup> enabled products which bear the Industrial<sup>IT</sup> symbol. According to the softstarter function they are grouped into the product suite 'Control<sup>IT</sup>'. Our customers can find all product related documentation such as brochures, catalogues, certificates and drawings, directly at [www.abb.com/lowvoltage](http://www.abb.com/lowvoltage).

## Softstarters

From the moment the first electrical motors appeared, engineers have been searching a way to avoid electrical and mechanical problems that occur using Direct-on-Line and Star-Delta starters. ABB has been producing softstarters since the beginning of the 1980's. The valuable experience gained since the early 80's has been incorporated into the design of today's product ranges. With the latest series named PST, ABB has taken a significant step further in soft starting technology. Matching modern power electronics with smart circuitry and software, the new PST softstarter offers superior electronic control of the current and voltage during motor start-up, in addition to several new design features.



## The solution to both mechanical and electrical problems

AC motors, "the workhorse of the industry", that are used to drive fans, crushers, agitators, pumps, conveyors etc., are unnecessarily causing unwanted load peaks day in and day out in production plants all over the world. These violent starts cause damage in several ways. Among them are:

- Electrical problems due to voltage and current transients arising from Direct-on-Line or Star-Delta starts. Such transients may overload the local supply network and cause unacceptable voltage variations that interfere with other electrical equipment connected to the network.
- Mechanical problems that address the entire drive chain, from motor to driven equipment, to severe stress.
- Operational problems, such as pressure surges in pipelines, damage to products on conveyor belts and uncomfortable escalator rides.

The financial consequences are considerable: every technical problem and every breakdown, costs money – in terms of repairs as well as lost production.

The easy solution to all of these problems is to install an ABB Softstarter type PSS or PST. With ABB Softstarters, it is possible to start and stop smoothly while keeping mechanical and electrical stresses to a minimum.

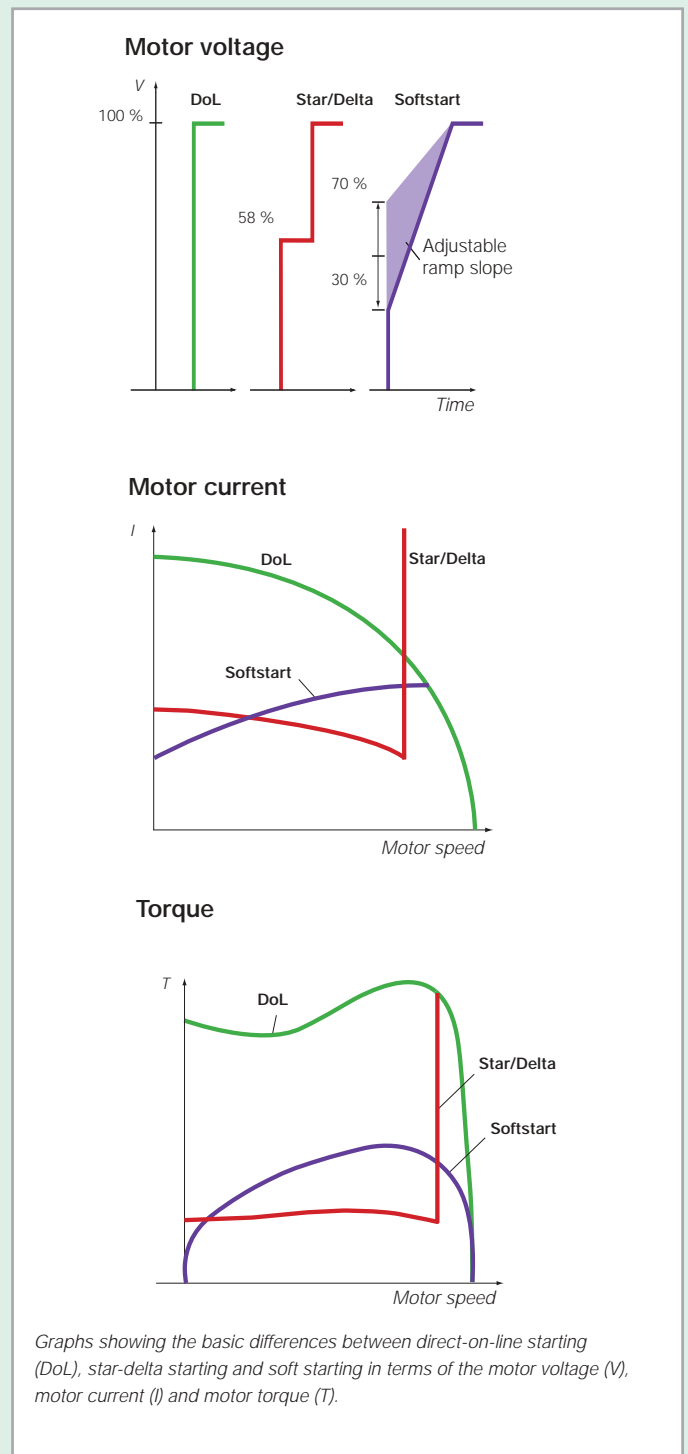

# Softstarters – the complete range

ABB offers three types of softstarters to cover every customer need from 3 A to 1810 A. The overview table at the very bottom of this page shows the main characteristics of the different types. For more specific technical details and ordering data, see the following pages.

**PSS03...25** The compact range covers motor currents from 3 to 25 A and has the following advantages:

- **Compact:** As a result, there is room for more products on a given mounting surface.
- **Easy to install:** The device is snapped onto a DIN mounting rail. Clear instructions are provided on the front.

**PSS18...300** The flexible range for motor currents from 18 to 515 A offers a solution possible to adapt to almost any application:

- **Flexible:** With two connection possibilities, either in line with the motor or inside the motor delta. Can also be equipped with current limit.
- **Easy to set up:** With just three clearly labeled rotary switches on the front of the unit it is possible to adjust the PSS Soft-starter for a wide range of applications.
- **Solid state electrical circuit:** This ensures the highest reliability and reduces maintenance to a minimum, even in applications with frequent starts and stops.

**PST30...PSTB1050** The new PST Softstarter range covers motor currents from 30 to 1810 A and offers you many advanced Softstarter functionalities:

- **Advanced integrated protections:** For the motor; integrated electronic overload relay, phase monitoring relays, high current and PTC protection. For the Softstarter; advanced thyristor protection.
- **Flexible bus communication system:** By using the ABB FieldBusPlug (FBP), you can decide at any time which bus system to select within the ABB FBP range. The interface between the PST Softstarter and the ABB FBP is always the same, independent of size and delivery date.
- **LCD display:** With 10 languages, a menu system similar to your mobile phone, preprogrammed application settings and automatic status and event logging, it couldn't be easier to set up and operate!
- **Programmable signal relays:** gives you several possibilities for signalling warnings, faults and other events.

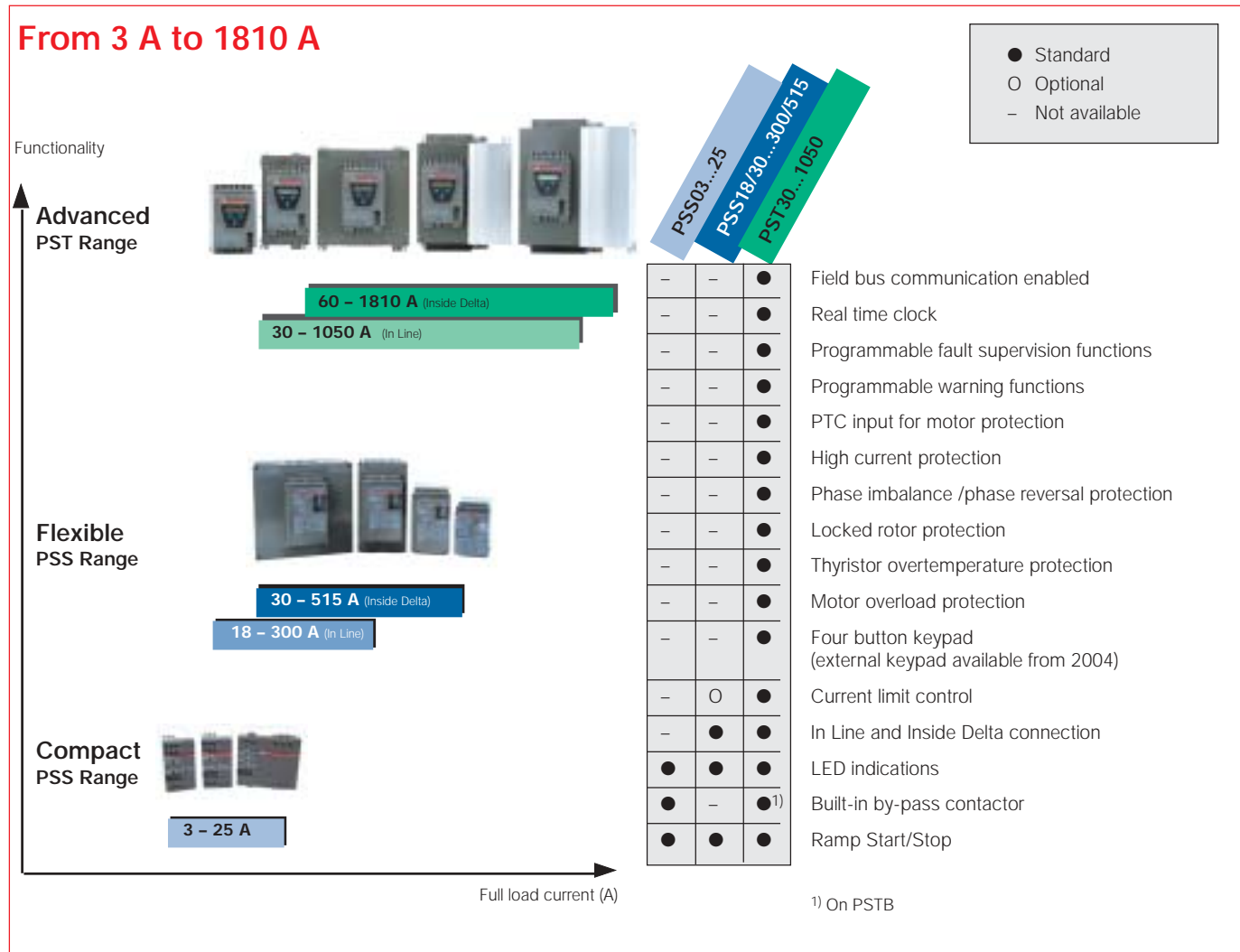

# Index

ControlIT Softstarters/Automation Technologies,  
IndustrialIT for Softstarters. 2

The solution to both mechanical and electrical problems 3

Softstarters –the complete range 4



## Overview – Softstarters type PSS 6

Softstarters type PSS03...PSS25  
Description & Ordering 8  
Technical data 13



Softstarters type PSS18/30...PSS300/515  
Description 9  
Ordering 10  
Accessories for PSS18/30...PSS300/515 12  
Technical data 13



## Overview – Softstarters type PST/PSTB 16

Softstarters type PST30 ...PSTB1050  
Description 18  
Ordering 20  
Accessories for PST30...PSTB1050 22  
FBP FieldBusPlug 23  
Technical data 26

Dimensions 30

Circuit diagrams 32

Wall mounting instruction 34

Some information about the catalogue:

### Ordering details:

When placing an order please give either the "Type" or the "Order code". Please note that for some of the products you need to fill in some additional code letters/code numbers to define the complete Type/Order code.

### Packing:

All softstarters and most of the accessories are delivered in an individual packing. Some of the accessories are packed together in batches of "n" pieces (see ordering "Packing pieces"). For these items, please order the total amount corresponding to a multiple of the number in the packing. Example: If two in the packing, then please order minimum two, four, six etc.

*Note: Each "Type" or "Order code" always corresponds to only one piece.*

The products described in this catalogue are subject to change (design, dimensions, technical data, etc) without prior notice.

# Softstarters, type PSS



PSS03, PSS12



PSS25



PSS18/30...PSS44/76

Normal start, 400 V

In Line connected

Inside Delta connected

	PSS03 ... PSS25			PSS18/30 ... PSS44/76			
kW	1.1 kW	5.5 kW	11 kW	7.5 kW	15 kW	18.5 kW	22 kW
kW	-	-	-	15 kW	25 kW	30 kW	37 kW
Type	PSS03	PSS12	PSS25	PSS18/30	PSS30/52	PSS37/64	PSS44/76
400 V	●	●	●	●	●	●	●
480 V	●	●	●	●	●	●	●
690 V	-	-	-	●	●	●	●
Rated current $I_e$ , A	3.5	12	25	18	30	37	44

## Fuse protection 400 V, 65 kA

Bussmann Type	170M1359	170M1363	170M1364	170M1364	170M1366	170M1368	170M1369
---------------	----------	----------	----------	----------	----------	----------	----------

## Switch fuse

Type	OS160RD0380
------	-------------

## Line contactor

Type	A9	A12	A26	A26	A30	A40	A50
------	----	-----	-----	-----	-----	-----	-----

## Thermal overload relay

Type	TA25DU	TA42DU	TA75DU
------	--------	--------	--------

## Current transformers

Type	-	-	-	PSCT-60 2 turns	PSCT-40 1 turn	PSCT-50 1 turn	PSCT-60 1 turn
------	---	---	---	--------------------	-------------------	-------------------	-------------------

## By-pass contactor

Type	-	-	-	A9	A16	A26	A26
------	---	---	---	----	-----	-----	-----

### How to select correct size

By using the guide below, you can quickly select a suitable softstarter for the most common applications.

If a more precise selection is required, you can use Prosoft, a selection software available at [www.abb.com/lowvoltage](http://www.abb.com/lowvoltage).

### Quick guide for selection

Normal start Class 10	Heavy duty start Class 30
<b>Typical applications</b> <ul style="list-style-type: none"> <li>● Bow thruster</li> <li>● Compressor</li> <li>● Elevator</li> <li>● Centrifugal pump</li> <li>● Conveyor belt (short)</li> <li>● Escalator</li> </ul>	<b>Typical applications</b> <ul style="list-style-type: none"> <li>● Centrifugal fan</li> <li>● Crusher</li> <li>● Mixer</li> <li>● Conveyor belt (long)</li> <li>● Mill</li> <li>● Stirrer</li> </ul>
<b>Standard selection</b> Type PSS: <b>Size according to the rated motor power.</b>	<b>Standard selection</b> Type PSS: <b>One size larger than the rated motor power.</b>
<p><b>!</b> If more than 10 starts /h Select <b>one</b> size larger than the standard selection.</p>	



1SFT98889-037

PSS50/85...PSS72/124



1SFT98889-038

PSS85/147... PSS142/245



1SFT98889-004

PSS175/300...PSS300/515

**PSS50/85 ... PSS72/124**

**PSS85/147... PSS142/245**

**PSS175/300 ... PSS300/515**

25 kW	30 kW	37 kW	45 kW	55 kW	75 kW	90 kW	132 kW	160 kW
45 kW	55 kW	59 kW	75 kW	90 kW	132 kW	160 kW	220 kW	257 kW
PSS50/85	PSS60/105	PSS72/124	PSS85/147	PSS105/181	PSS142/245	PSS175/300	PSS250/430	PSS300/515
●	●	●	●	●	●	●	●	●
●	●	●	●	●	●	●	●	●
●	●	●	●	●	●	●	●	●
50	60	72	85	105	142	175	250	300

**Fuse protection 400 V, 65 kA**

170M1369	170M1370	170M1371	170M1371	170M1372	170M3020	170M3021	170M4016	170M4017
----------	----------	----------	----------	----------	----------	----------	----------	----------

**Switch fuse**

OS160RD0380	—————	OESA250R03D80	—————	OESA400R03D80
-------------	-------	---------------	-------	---------------

**Line contactor**

A50	A63	A75	A95	A110	A145	A185	A260	A300
-----	-----	-----	-----	------	------	------	------	------

**Thermal overload relay**

TA75DU	—————	TA110DU	—————	TA200DU	—————	TA450DU
--------	-------	---------	-------	---------	-------	---------

**Current transformers**

PSCT-75 1 turn	—————	PSCT-100 1 turn	PSCT-125 1 turn	PSCT-150 1 turn	PSCT-200 1 turn	PSCT-250 1 turn	PSCT-400 1 turn	—————
-------------------	-------	--------------------	--------------------	--------------------	--------------------	--------------------	--------------------	-------

**By-pass contactor**

A30	A40	A50	A50	A63	A75	A110	A145	A210
-----	-----	-----	-----	-----	-----	------	------	------

# PSS03 ... PSS25

## For normal starts

### Application

The softstarter types **PSS03 ... PSS25** are compact solutions for small motors. It is easy to install and to adjust as access for connections and adjustments is from the front. The unit is for DIN-rail mounting.

### Description

- Current ratings 3, 12 and 25 A
- Main voltage levels 230, 400, 480 - 500 and 600 V
- Control voltage range 24-110 V AC/DC and 110-480 V AC
- Settings for Start ramp, Stop ramp and Initial Voltage
- For mounting on 35 mm DIN-rail
- Built-in by-pass contacts

### Operator panels

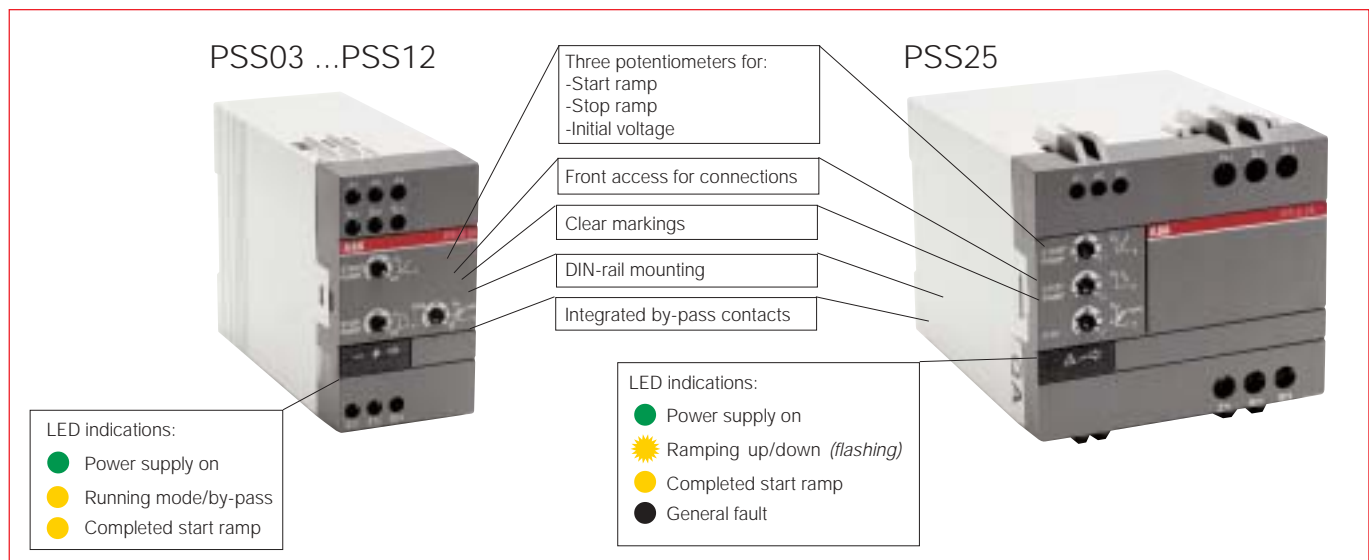
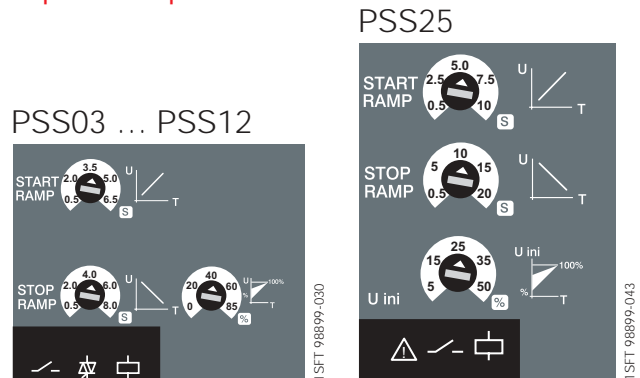

### Ordering details

#### 230 – 600 V

##### Motor power

230 V	400 V	500 V	600 V	Rated motor current, $I_e$ A	Type <sup>1)</sup>	Order code	Weight kg
$P_e$ kW	$P_e$ kW	$P_e$ kW	$P_e$ kW				
0.75	-	-	-	3.5	PSS03-220B	1SFA 891 001 R2209	0.27
3.0	-	-	-	12	PSS12-220B	1SFA 891 002 R2209	0.27
6.5	-	-	-	25	PSS25-220B	1SFA 891 003 R2209	0.60
-	1.1	-	-	3.5	PSS03-400B	1SFA 891 001 R4009	0.27
-	5.5	-	-	12	PSS12-400B	1SFA 891 002 R4009	0.27
-	11.0	-	-	25	PSS25-400B	1SFA 891 003 R4009	0.60
-	-	1.5	-	3.5	PSS03-480B	1SFA 891 001 R4809	0.27
-	-	5.5	-	12	PSS12-480B	1SFA 891 002 R4809	0.27
-	-	15.0	-	25	PSS25-480B	1SFA 891 003 R4809	0.60
-	-	-	7.5	12	PSS12-600B	1SFA 891 002 R6009	0.27
-	-	-	18.5	25	PSS25-600B	1SFA 891 003 R6009	0.60

##### <sup>1)</sup> Control voltage, $U_c$

Type	V, AC/DC	V, AC
220B	24-110	110-230
400B	24-110	110-400
480B	24-110	110-500
600B	24-110	110-500

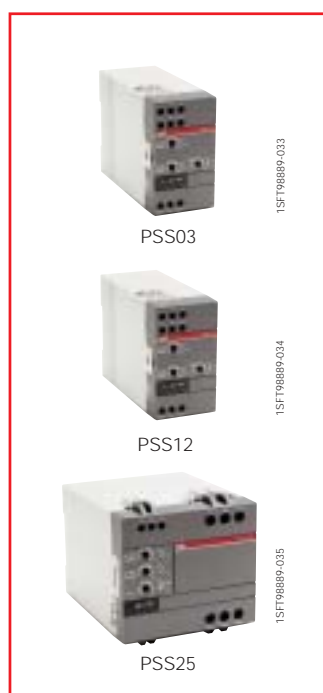

# PSS18/30 ... PSS300/515

For normal starts

## Application

The softstarter range **PSS18/30 ... PSS300/515** is a very flexible solution suitable for most applications and for replacements of Star-Delta starters. Since the unit can be connected inside the motor delta (compare the connection for standard Star-Delta starters), the current through the softstarter is reduced by 42 %. It will then be possible, for example, to run a 100 A motor using a 58 A PSS Softstarter.

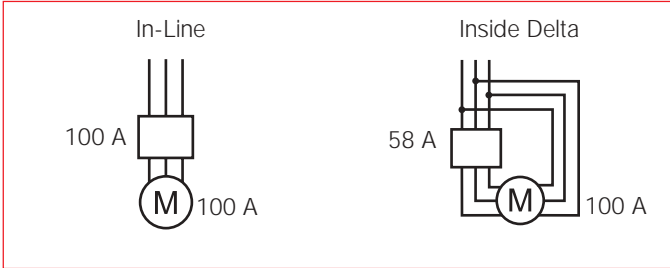

In-Line and Inside Delta connection of PSS18/30 ... PSS300/515

The PSS Softstarter can be selected according to the rated motor power in **normal duty** applications like pumps, compressors, elevators, escalators, short conveyor belts and bow thrusters.

For **heavy duty** applications like centrifugal fans, crushers, mixers, stirrers and long conveyor belts, we recommend you to select a one size larger softstarter than the rated motor power.

See also quick guide for selection, page 6

## Operator panel

PSS18/30 ... PSS300/515

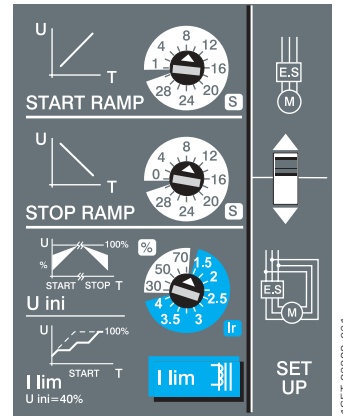

## Description

- Wide main voltage range 208 - 690 V AC
- Supply voltage range 110-120 V AC and 220-240 V AC
- Current ratings 18 ... 300 A (In Line) and 30 ... 515 A (Inside Delta)
- Same unit can be used for both In Line and Inside Delta connection
- Start ramp, Stop ramp and Initial voltage included
- Current limit function as option
- Solid state electrical circuit
- Designed for continuous operation without by-pass
- 15 % overcurrent capability during continuous run (10 % for PSS300)
- Accessories for connection and installation available: See the ordering pages

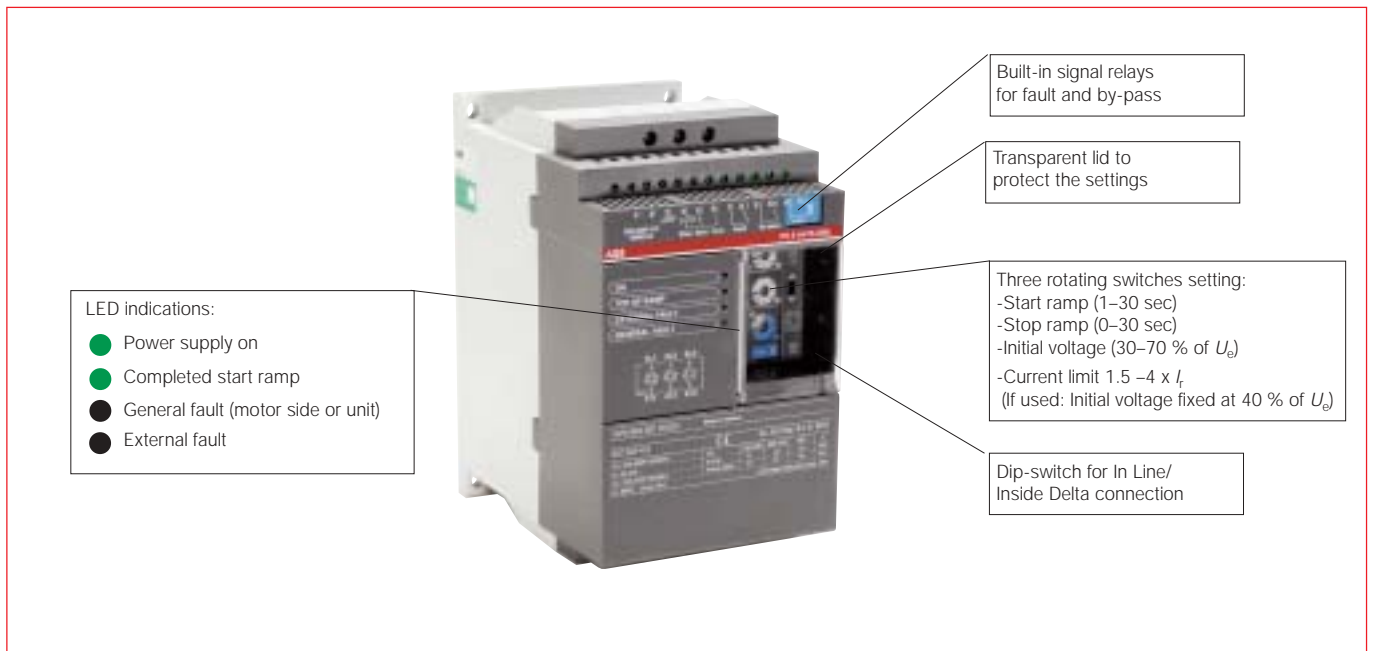

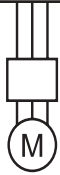

# PSS18/30 ... PSS300/515

For normal starts. In-Line

## Ordering details. In-Line

**How to select correct size for heavy duty starts**

See the quick guide on page 6.



1SFT98889-026

PSS18/30-500 ... 44/76-500



1SFT98889-037

PSS50/85-500 ... 72/124-500  
PSS18/30-690 ... 72/124-690



1SFT98889-038

PSS85/147-500 ... 142/245-500  
PSS85/147-690 ... 142/245-690



1SFT98800-004

PSS175/300-500 ... 300/515-500  
PSS175/300-690 ... 300/515-690

### 230 – 500 V

#### Motor power

400 V $P_e$ kW	500 V $P_e$ kW	690 V $P_e$ kW	Rated motor current, $I_e$ A	Type <sup>1)</sup>	Order code <sup>2)</sup>	Weight kg
7.5	11	-	18	PSS18/30-500□	1SFA 892 001 R▽00▽	2.30
15	18.5	-	30	PSS30/52-500□	1SFA 892 002 R▽00▽	2.30
18.5	22	-	37	PSS37/64-500□	1SFA 892 003 R▽00▽	2.30
22	25	-	44	PSS44/76-500□	1SFA 892 004 R▽00▽	2.30
25	30	-	50	PSS50/85-500□	1SFA 892 005 R▽00▽	3.60
30	37	-	60	PSS60/105-500□	1SFA 892 006 R▽00▽	3.80
37	45	-	72	PSS72/124-500□	1SFA 892 007 R▽00▽	3.80
45	55	-	85	PSS85/147-500□	1SFA 892 008 R▽00▽	8.60
55	75	-	105	PSS105/181-500□	1SFA 892 009 R▽00▽	10.40
75	90	-	142	PSS142/245-500□	1SFA 892 010 R▽00▽	10.40
90	110	-	175	PSS175/300-500□	1SFA 892 011 R▽00▽	20.50
132	160	-	250	PSS250/430-500□	1SFA 892 013 R▽00▽	22.00
160	200	-	300	PSS300/515-500□	1SFA 892 014 R▽00▽	22.00

### 400 – 690 V

#### Motor power

400 V $P_e$ kW	500 V $P_e$ kW	690 V $P_e$ kW	Rated motor current, $I_e$ A	Type <sup>1)</sup>	Order code <sup>2)</sup>	Weight kg
7.5	11	15	18	PSS18/30-690□	1SFA 893 001 R▽00▽	2.30
15	18.5	25	30	PSS30/52-690□	1SFA 893 002 R▽00▽	2.30
18.5	22	30	37	PSS37/64-690□	1SFA 893 003 R▽00▽	2.30
22	25	37	44	PSS44/76-690□	1SFA 893 004 R▽00▽	2.30
25	30	45	50	PSS50/85-690□	1SFA 893 005 R▽00▽	3.60
30	37	55	60	PSS60/105-690□	1SFA 893 006 R▽00▽	3.80
37	45	59	72	PSS72/124-690□	1SFA 893 007 R▽00▽	3.80
45	55	75	85	PSS85/147-690□	1SFA 893 008 R▽00▽	8.60
55	75	90	105	PSS105/181-690□	1SFA 893 009 R▽00▽	10.40
75	90	132	142	PSS142/245-690□	1SFA 893 010 R▽00▽	10.40
90	110	160	175	PSS175/300-690□	1SFA 893 011 R▽00▽	20.50
132	160	220	250	PSS250/430-690□	1SFA 893 013 R▽00▽	22.00
160	200	257	300	PSS300/515-690□	1SFA 893 014 R▽00▽	22.00

<sup>1)</sup> Add code letter in Type for:

- Supply voltage,  $U_s$**
- F = 110-120 V, 50/60 Hz
  - L = 220-240 V, 50/60 Hz

**Fault signal relay**

- no code letter = NO
- C = NC

<sup>2)</sup> Add code number in Order code for:

- Supply voltage,  $U_s$**
- ▽ 1 = 110-120 V, 50/60 Hz
  - ▽ 2 = 220-240 V, 50/60 Hz

**Fault signal relay**

- ▽ 1 = NO
- ▽ 2 = NC

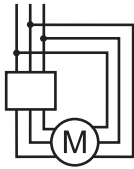

# PSS18/30 ... PSS300/515

For normal starts. Inside Delta

## Ordering details. Inside Delta

**How to select correct size for heavy duty starts**

See the quick guide on page 6.



PSS18/30-500 ... 44/76-500

1SFT988B9-036



PSS50/85-500 ... 72/124-500  
PSS18/30-690 ... 72/124-690

1SFT988B9-037



PSS85/147-500 ... 142/245-500  
PSS85/147-690 ... 142/245-690

1SFT988B9-038



PSS175/300-500 ... 300/515-500  
PSS175/300-690 ... 300/515-690

1SFT988C0-004

### 230 – 500 V

#### Motor power

400 V $P_e$ kW	500 V $P_e$ kW	690 V $P_e$ kW	Rated motor current, $I_e$ A	Type <sup>*)</sup>	Order code <sup>**)</sup>	Weight kg
15	18.5	-	30	PSS18/30-500□■	1SFA 892 001 R▽00▼	2.30
25	30	-	52	PSS30/52-500□■	1SFA 892 002 R▽00▼	2.30
30	37	-	64	PSS37/64-500□■	1SFA 892 003 R▽00▼	2.30
37	45	-	76	PSS44/76-500□■	1SFA 892 004 R▽00▼	2.30
45	55	-	85	PSS50/85-500□■	1SFA 892 005 R▽00▼	3.60
55	75	-	105	PSS60/105-500□■	1SFA 892 006 R▽00▼	3.80
59	80	-	124	PSS72/124-500□■	1SFA 892 007 R▽00▼	3.80
75	90	-	147	PSS85/147-500□■	1SFA 892 008 R▽00▼	8.60
90	110	-	181	PSS105/181-500□■	1SFA 892 009 R▽00▼	10.40
132	160	-	245	PSS142/245-500□■	1SFA 892 010 R▽00▼	10.40
160	200	-	300	PSS175/300-500□■	1SFA 892 011 R▽00▼	20.50
220	295	-	430	PSS250/430-500□■	1SFA 892 013 R▽00▼	22.00
257	355	-	515	PSS300/515-500□■	1SFA 892 014 R▽00▼	22.00

### 400 – 690 V

#### Motor power

400 V $P_e$ kW	500 V $P_e$ kW	690 V $P_e$ kW	Rated motor current, $I_e$ A	Type <sup>*)</sup>	Order code <sup>**)</sup>	Weight kg
15	18.5	25	30	PSS18/30-690□■	1SFA 893 001 R▽00▼	2.30
25	30	45	52	PSS30/52-690□■	1SFA 893 002 R▽00▼	2.30
30	37	55	64	PSS37/64-690□■	1SFA 893 003 R▽00▼	2.30
37	45	59	76	PSS44/76-690□■	1SFA 893 004 R▽00▼	2.30
45	55	75	85	PSS50/85-690□■	1SFA 893 005 R▽00▼	3.60
55	75	90	105	PSS60/105-690□■	1SFA 893 006 R▽00▼	3.80
59	80	110	124	PSS72/124-690□■	1SFA 893 007 R▽00▼	3.80
75	90	132	147	PSS85/147-690□■	1SFA 893 008 R▽00▼	8.60
90	110	160	181	PSS105/181-690□■	1SFA 893 009 R▽00▼	10.40
132	160	220	245	PSS142/245-690□■	1SFA 893 010 R▽00▼	10.40
160	200	257	300	PSS175/300-690□■	1SFA 893 011 R▽00▼	20.50
220	295	400	430	PSS250/430-690□■	1SFA 893 013 R▽00▼	22.00
257	355	500	515	PSS300/515-690□■	1SFA 893 014 R▽00▼	22.00

<sup>\*)</sup> Add code letter in Type for:

Supply voltage,  $U_s$

- F = 110-120 V, 50/60 Hz
- L = 220-240 V, 50/60 Hz

Fault signal relay

- no code letter = NO
- C = NC

<sup>\*\*)</sup> Add code number in Order code for:

Supply voltage,  $U_s$

- ▼ 1 = 110-120 V, 50/60 Hz
- ▽ 2 = 220-240 V, 50/60 Hz

Fault signal relay

- ▽ 1 = NO
- ▼ 2 = NC

# Accessories for PSS18/30 ... PSS300/515

## Ordering details

### Current transformer for current limit function

To be connected to terminals 11 and 12 on the softstarter.  
The setting range (1.5 – 4) corresponds to a multiple of the transformer ratio.  
Technical data below shows transformer ratio and number of turns for the primary winding.  
You can also use your own current transformer with corresponding transformer ratio and with minimum 1 VA.

For softstarter type	Transformer ratio, Number of turns	Type	Order code	Pack <sup>ing</sup>	Weight
				piece	kg 1 piece
PSS18/30	60/1 – 2 turns	PSCT-60	1SFA 899 001 R1060	1	0.30
PSS30/52	60/1 – 1 turn	PSCT-40	1SFA 899 001 R1040	1	0.30
PSS37/64	60/1 – 1 turn	PSCT-50	1SFA 899 001 R1050	1	0.30
PSS44/76	60/1 – 1 turn	PSCT-60	1SFA 899 001 R1060	1	0.30
PSS50/85	75/1 – 1 turn	PSCT-75	1SFA 899 001 R1075	1	0.30
PSS60/105	75/1 – 1 turn	PSCT-75	1SFA 899 001 R1075	1	0.30
PSS72/124	100/1 – 1 turn	PSCT-100	1SFA 899 001 R1100	1	0.25
PSS85/147	125/1 – 1 turn	PSCT-125	1SFA 899 001 R1125	1	0.25
PSS105/181	150/1 – 1 turn	PSCT-150	1SFA 899 001 R1150	1	0.25
PSS142/245	200/1 – 1 turn	PSCT-200	1SFA 899 001 R1200	1	0.25
PSS175/300	250/1 – 1 turn	PSCT-250	1SFA 899 001 R1250	1	0.25
PSS250/430	400/1 – 1 turn	PSCT-400	1SFA 899 001 R1400	1	0.25
PSS300/515	400/1 – 1 turn	PSCT-400	1SFA 899 001 R1400	1	0.25

### Cable connectors for Cu cables

For softstarter type	Wire range mm <sup>2</sup>	Tightening torque max. Nm	Type	Order code	Pack <sup>ing</sup>	Weight
					piece	kg 1 piece
PSS85/147...142/245	6-120	16	-	1SDA 023 354 R0001	3	0.20
PSS85/147...142/245	2x(50-120)	16	LZ185-2C/120	1SFN 074 709 R1000	3	0.30
PSS175/300...300/515	16-240	25	-	1SDA 023 368 R0001	3	0.40

### Cable connectors for Al and Cu cables

For softstarter type	Wire range mm <sup>2</sup>	Tightening torque max. Nm	Type	Order code	Pack <sup>ing</sup>	Weight
					piece	kg 1 piece
PSS85/147...142/245	35-95	13.5	-	1SDA 023 356 R0001	3	0.10
PSS85/147...142/245	25-150	31	-	1SDA 023 357 R0001	3	0.10
PSS175/300...300/515	120-240	43	-	1SDA 023 370 R0001	3	0.10

### Terminal shrouds

For softstarter type	Suitable for	Type	Order code	Pack <sup>ing</sup>	Weight
				piece	kg 1 piece
PSS85/147...142/245	Cable connectors	LT185-AC	1SFN 124 701 R1000	2	0.10
PSS85/147...142/245	Compression lugs	LT185-AL	1SFN 124 703 R1000	2	0.10
PSS175/300...300/515	Cable connectors	LT300-AC	1SFN 125 101 R1000	2	0.20
PSS175/300...300/515	Compression lugs	LT300-AL	1SFN 125 103 R1000	2	0.20

### Terminal nut washer

For softstarter type	Type	Order code	Pack <sup>ing</sup>	Weight
			piece	kg 1 piece
PSS85/147...142/245	LE185	1SFN 074 716 R1000	2	0.20
PSS175/300...300/515	LE300	1SFN 075 116 R1000	2	0.30

### Terminal enlargements

For softstarter type	Wire range mm <sup>2</sup>	Type	Order code	Pack <sup>ing</sup>	Weight
				piece	kg 1 piece
PSS18/30-500 ...44/76-500	1x6...35 2x6...16	PSLW-44	1SFA 899 002 R1044	1	0.10
PSS50/85-500...72/124-500					
PSS18/30-690 ... 72/124-690	1x10...50 2x10...25	PSLW-72	1SFA 899 002 R1072	1	0.15
PSS85/147...142/245		LW185	1SFA 074 707 R1000	1	0.25
PSS175/300...300/515		LW300	1SFA 075 107 R1000	1	0.40



# PSS03 ... PSS25, and PSS18/30 ... PSS300/515

## Technical data

		PSS03...PSS12	PSS25	PSS18/30...PSS300/515
Rated insulation voltage, $U_i$	V	630	630	690
Rated operational voltage, $U_e$	V	220 – 230 400 – 415 480 – 500 600	220 – 230 400 – 415 480 – 500 600	208 – 690
Starting capacity at max. rated current, $I_e$		5 x $I_e$ for 5 sec	5 x $I_e$ for 5 sec	4 x $I_e$ for 10 sec
Number of starts per hour		6 <sup>2)</sup>	6 <sup>2)</sup>	30 <sup>5)</sup>
Overload capability	class	10	10	10
Service factor	%	100	100	115 (PSS18/30...250/430) 110 (PSS300/515)
<b>Ambient temperature</b>				
During operation	°C	-20 – +50	-20 – +50	-25 – +60 <sup>1)</sup>
During storage	°C	-40 – +70	-40 – +70	-40 – +70
<b>Altitudes</b>				
Maximum altitude	m	4000 <sup>6)</sup>	4000 <sup>6)</sup>	4000 <sup>6)</sup>
<b>Degree of protection</b>				
Main circuit		IP 20	IP 20	IP 20 (PSS18/30-500...44/76-500) IP 10 (PSS50/85 500...72/124-500) IP 10 (PSS18/30-690...72/124-690) IP 00 (PSS85/147...300/515)
Supply and control circuit		IP 20	IP 20	IP 20
<b>Settings</b>				
Ramp time during start	s	0.5 – 6.5 ± 15%	0.5 – 10 ± 10%	1 – 30
Ramp time during stop	s	0.5 – 8 ± 25%	0.5 – 20 ± 10%	0 – 30
Initial voltage during start	%	0 – 85 ± 15%	0.5 – 50 ± 5%	30 – 70
Current limit function	x CT-ratio	–	–	1.5 ... 4 <sup>3)</sup>
<b>Switch for</b>				
Inside Delta connection	ON/OFF	No	No	Yes
<b>Signal relay</b>				
By-pass signal		No <sup>4)</sup>	No <sup>4)</sup>	Yes
Fault signal		No	No	Yes (NO or NC)
Rated operational voltage, $U_e$	V	–	–	250
Rated thermal current, $I_{th}$	A	–	–	5
Rated operational current $I_e$ at AC-15 ( $U_e=250$ V)	A	–	–	1.5
<b>Signal indication LED</b>				
Ready to start/stand by	ON	Green	Green	Green
Ramping up/down		Yellow	Yellow (flashing)	–
Completed start ramp	T.O.R.	Yellow	Yellow	Green
General fault		–	Red	Red
External fault		–	–	Red

1) Above 40 °C, up to max 60 °C, reduce the rated current with 0.8 % per °C.

2) When more than 6 starts per hour are required, contact your sales office.

3) Only if current transformer is connected (accessory).

4) The unit has built in by-pass contacts (AC-53b).

5) Valid for 50 % on time and 50 % off time. 3.5 x  $I_e$  for 7 sec., if other data is required, contact your sales office.

6) When used at high altitudes above 1000 meters up to 4000 meters you need to derate rated current using the following formula.

$$[ \% \text{ of } I_e = 100 - \frac{x - 1000}{150} ]$$

x = actual altitude for the softstarter

# PSS03 ... PSS25, and PSS18/30 ... PSS300/515

## Technical data

### Cross section of connection cables PSS03 ... PSS25 and PSS18/30 ... PSS300/515

Type PSS		03... 12	25	18/30-500 ... 44/76-500	50/85-500 ... 72/124-500 18/30-690 ... 72/124-690	85/147-500 ... 142/245-500 85/147-690 ... 142/245-690	175/300 ... 300/515-500 175/300 ... 300/515-690
<b>Main circuit</b>							
Connection clamp							
Solid/Stranded	1 x mm <sup>2</sup>	2.5	10	2.5 – 16	6 – 50	See accessories	See accessories
Solid/Stranded	2 x mm <sup>2</sup>	2.5	6	2.5 – 16	6 – 25	See accessories	See accessories
Tightening torque (recommended)		Nm	0.5	2	2.6	4.5	See accessories
Connection bar							
Width and thickness		mm	–	–	–	17.5 x 5	20 x 5
Hole diameter		mm	–	–	–	8.5	10.2
Tightening torque (recommended)		Nm	–	–	–	9	18
<b>Supply and control circuit</b>							
Connection clamp							
Solid/Stranded	1 x mm <sup>2</sup>	2.5	2.5	2.5	2.5	2.5	2.5
Solid/Stranded	2 x mm <sup>2</sup>	2.5	–	–	–	–	–
Tightening torque (recommended)		Nm	0.5	0.5	0.5	0.5	0.5

### Size related technical data PSS03 ... PSS25 and PSS18/30 ... PSS300/515

For Softstarter Size	Recommended ABB Overload protection Type	Current range A	Max power loss at max I <sub>e</sub> W	Max fuse rating main circuit <sup>1)</sup>			Ferraz fuses circuit		Power requirements of supply VA	
				Bussman fuses			A			Type
				A	Type	Holder	A	Type		
PSS03	TA 25 DU	2.2–3.1	–	16	170M1359	170H1007			2	
PSS12	TA 25 DU	10–14	–	40	170M1363	170H1007			2	
PSS25	TA 25 DU	18–25	–	50	170M1364	170H1007			5	
PSS18/30	TA 25 DU	6–18	65	50	170M1364	170H1007	63	6.6 URB 000 D08 V 0063	9	
PSS30/52	TA 25 DU	10–30	100	80	170M1366	170H1007	100	6.6 URB 000 D08 V 0100	9	
PSS37/64	TA 42 DU	22–37	120	125	170M1368	170H1007	160	6.6 URB 000 D08 V 0160	9	
PSS44/76	TA 75 DU	29–44	142	160	170M1369	170H1007	200	6.6 URD 30 D08 A 0200	9	
PSS50/85	TA 75 DU	29–50	160	160	170M1369	170H1007	200	6.6 URD 30 D08 A 0200	10	
PSS60/105	TA 75 DU	29–60	190	200	170M1370	170H1007	250	6.6 URD 30 D08 A 0250	10	
PSS72/124	TA 75 DU	45–72	226	250	170M1371	170H1007	315	6.6 URD 30 D08 A 0315	10	
PSS85/147	TA 110 DU	65–85	291	315	170M1372	170H1007	400	6.6 URD 30 D08 A 0400	36	
PSS105/181	TA 110 DU	65–105	351	400	170M3019	170H3004	400	6.6 URD 30 D08 A 0400	36	
PSS142/245	TA 200 DU	100–142	462	450	170M3020	170H3004	500	6.6 URD 30 D08 A 0500	36	
PSS175/300	TA 200 DU	100–175	590	500	170M3021	170H3004	530	6.6 URD 30 D08 A 0550	65	
PSS250/430	TA 450 DU	130–250	815	700	170M4017	170H3004	630	6.6 URD 31 D08 A 0630	65	
PSS300/515	TA 450 DU	130–300	965	900	170M5015	170H3004	900	6.6 URD 32 D11 A 0900	65	

<sup>1)</sup> For the supply circuit 6 A delayed, for MCB use C characteristics.



# Softstarters, type PST/PSTB



PST30 ... PST72



PST85 ... PST142

Normal start, 400 V

In Line connected

Inside Delta connected

	PST30 ... PST72						PST85 ... PST142		
kW	15 kW	18.5 kW	22 kW	25 kW	30 kW	37 kW	45 kW	55 kW	75 kW
kW	25 kW	30 kW	37 kW	45 kW	55 kW	59 kW	75 kW	90 kW	132 kW
Type	PST30	PST37	PST44	PST50	PST60	PST72	PST85	PST105	PST142
400 V	●	●	●	●	●	●	●	●	●
500 V	●	●	●	●	●	●	●	●	●
690 V	●	●	●	●	●	●	●	●	●
Rated current $I_e$ , A	30	37	44	50	60	72	85	105	142

## Fuse protection 400 V, 65 kA

Bussmann Type

170M1366 170M1368 170M1369 170M1369 170M1370 170M1371 170M1372 170M3019 170M3020

## Switch fuse

Type

OS160RD0380

OESA250R03D80

## Line contactor

Type

A30 A40 A50 A50 A63 A75 A95 A110 A145

## By-pass contactor

Type

A16 A26 A26 A30 A40 A50 A50 A63 A75

### How to select correct size

By using the guide below, you can quickly select a suitable softstarter for the most common applications.

If a more precise selection is required, you can use Prosoft, a selection software available at [www.abb.com/lowvoltage](http://www.abb.com/lowvoltage).

### Quick guide for selection

#### Normal start Class 10

##### Typical applications

- Bow thruster
- Centrifugal pump
- Compressor
- Conveyor belt (short)
- Elevator
- Escalator

##### Standard selection

Type PST: **Size according to the rated motor power.**

#### Heavy duty start Class 30

##### Typical applications

- Centrifugal fan
- Conveyor belt (long)
- Crusher
- Mill
- Mixer
- Stirrer

##### Standard selection

Type PST: **One size larger than the rated motor power.**



**If more than 10 starts /h**

Select **one** size larger than the standard selection.



1SFC132018F0201

PST175 ... PST300



1SFC132018F0201

PSTB370 ... PSTB470



1SFC132014F0201

PSTB570 ... PSTB1050

PST175 ... PST300				PSTB370 ... PSTB470		PSTB570 ... PSTB1050			
90 kW	110 kW	132 kW	160 kW	200 kW	250 kW	315 kW	400 kW	450 kW	560 kW
160 kW	184 kW	220 kW	257 kW	355 kW	450 kW	475 kW	670 kW	780 kW	875 kW
PST175	PST210	PST250	PST300	PSTB370	PSTB470	PSTB570	PSTB720	PSTB840	PSTB1050
●	●	●	●	●	●	●	●	●	●
●	●	●	●	●	●	●	●	●	●
●	●	●	●	●	●	●	●	●	●
175	210	250	300	370	470	570	720	840	1050

### Fuse protection 400 V, 65 kA Bussmann type

170M3021	170M5012	170M5013	170M5015	170M5013	170M5015	170M6015	170M5018	170M6018	170M6020 <sup>2)</sup>
----------	----------	----------	----------	----------	----------	----------	----------	----------	------------------------

### Switch fuse

OESA250R03D80	OESA400R03D80	—————	OESA630R03D80	—————	OESA800R03D80 <sup>1)</sup>	1)
---------------	---------------	-------	---------------	-------	-----------------------------	----

### Line contactor

A185	A210	A260	A300	AF400	AF460	AF580	AF750	–	–
------	------	------	------	-------	-------	-------	-------	---	---

### By-pass contactor

A110	A145	A145	A210	Built-in	Built-in	Built-in	Built-in	Built-in	Built-in
------	------	------	------	----------	----------	----------	----------	----------	----------

<sup>1)</sup> PSTB840 and PSTB1050: Switch fuse not available, use fuseholder, see page 29.

<sup>2)</sup> PST1050-690-70 has 170M6019

# PST30 ... 300 and PSTB370 ... 1050

## Application and description

### Application

The PST range is a microprocessor based softstarter designed with the latest technology for soft start and soft stop of motors. The PST Softstarter has several advanced motor protection features as standard. The four button keypad and the logic structure of the menu make the installation, commissioning and operation easy. It is possible to choose between 10 different languages.

The PST Softstarter can be used with or without a by-pass contactor except for the larger sizes PSTB370 ... PSTB1050 where the by-pass contactor is already built-in.

The PST Softstarter can be selected according to the rated motor power in **normal duty** applications like pumps, compressors, elevators, escalators, short conveyor belts and bow thrusters.

For **heavy duty** applications like centrifugal fans, crushers, mixers, mills, stirrers and long conveyor, belts we recommend you to select a one size larger softstarter than the rated motor power.

See also quick guide for selection, page 16

### Description

- Wide main voltage range 208 - 690 V AC
- Wide supply voltage range 100 – 250 V, 50/60 Hz
- Current ratings 30 to 1050 A (In Line) and 52 ... 1810 A (Inside Delta)
- Same unit can be used for both In Line and Inside Delta connection
- Premium adjustable Softstarter functions like start/stop ramp, kick start, jog, step down voltage and sequential starts.
- Current limit adjustable between  $2-5 \times I_e$
- Thermistor (PTC) supervision of motor winding
- Real time clock
- Logging of last 20 events with time marking
- Prepared for fieldbus communication
- Motor overload protection with simulated motor temperature from measured current. Select between 10A, 10, 20 and 30
- Locked rotor protection
- Motor underload protection
- Phase imbalance protection
- Phase reversal protection

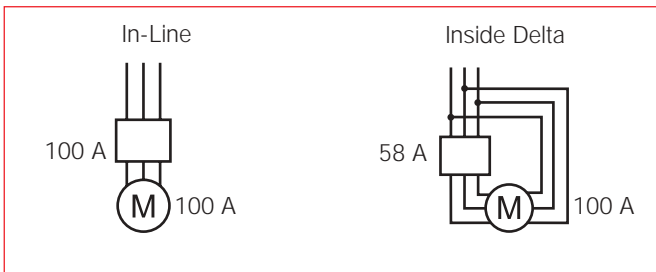

In-Line and Inside Delta connection of PST 30 ... 1050

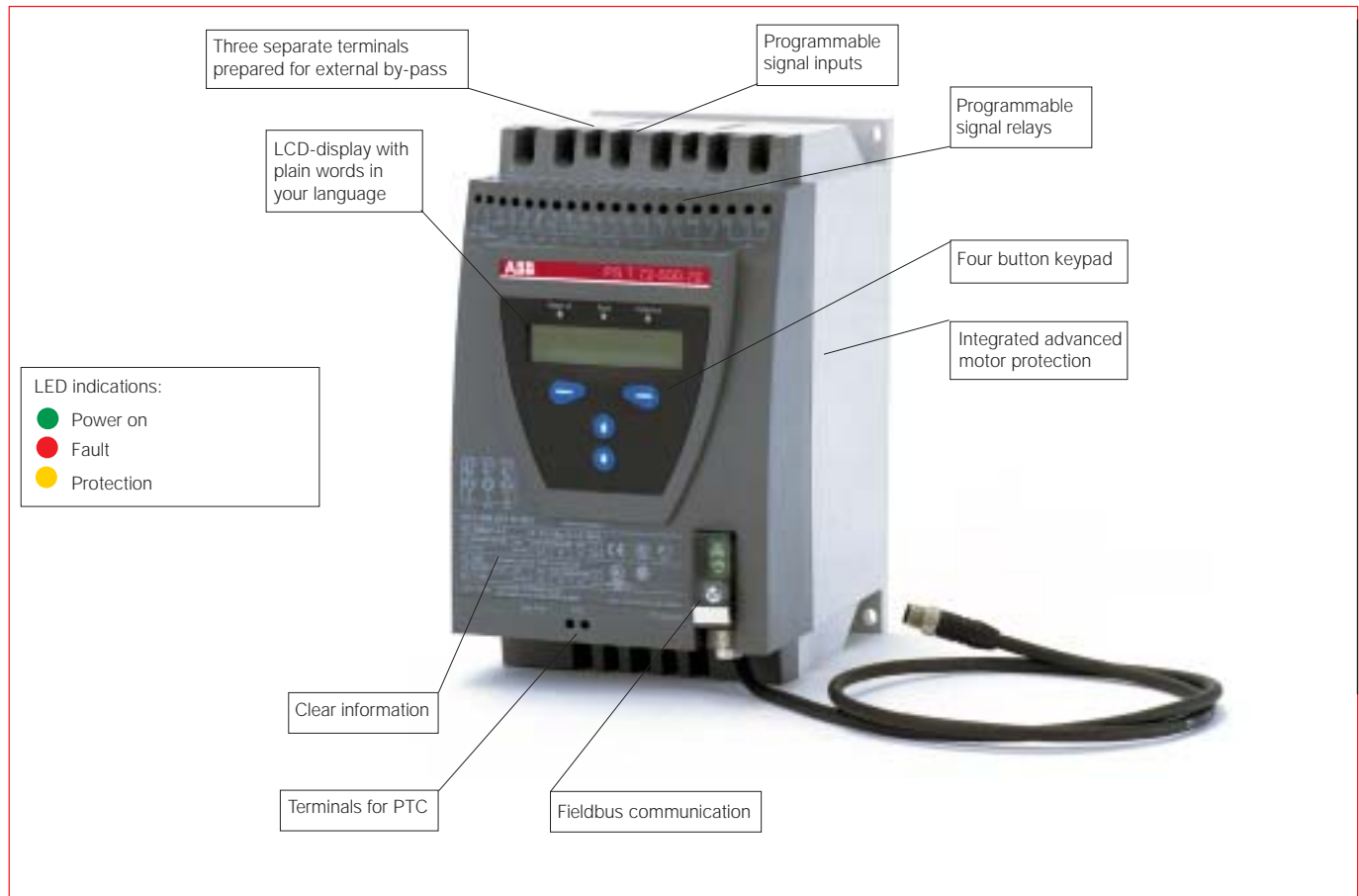

# PST30 ... 300 and PSTB370 ... 1050

## Functional description

### LCD display

The display of the PST gives you information presented in plain words - in required language. You can choose between 10 different languages including English, German, Italian, Chinese, Finnish, Swedish, French, Spanish, Dutch, and Portuguese. On the PST display, you get all the information you need to set up, adjust and trouble-shoot. This makes the PST extremely easy to handle and reduces the risk of misinterpretations.

At any time, you can read output current, output voltage, number of starts, total run time and motor temperature on the display. If a fault should occur, this is also indicated on the LCD. The fault messages are presented in clear text in the selected language.

### Four button keypad

The PST employs the same basic user concept as today's advanced mobile telephones. Using the four buttons on the keypad, you can easily adjust your own start and stop profile and motor protection functions for any type of application. There are standard settings for many common applications including pumps, conveyors, fans, mixers and compressors for quick and easy set up.

You can also set the advanced warning parameters to allow potential problems to be identified before real problems occur. A password protection function is available to prevent unauthorized changes to the programming.

### Starting several motors

You can store as many as three different starting parameter sets for optimal sequence start of three different motors. You can use this function for two or three speed motors as well.

### Integrated advanced motor protection

Inside the PST Softstarter, you will find useful features for advanced motor and softstarter protection, including: programmable overload protection, high current, underload, phase imbalance, phase reversal, thyristor overload protection, and bypass monitoring to ensure proper by-pass operation

### Programmable signal relays

All PST units have three programmable signal relays where each relay can signal Run, Top of Ramp or Event. The Event setting can be used to signal protections, faults and warnings. The supervisory functions monitor not only software and critical softstarter functionality but also phase loss and out of frequency range.

### Integrated by-pass contactor

On the larger sizes (PSTB 370 ... PSTB1050), there is an ABB AF contactor integrated. This gives you advantages in terms of cost-saving, space saving and last but not least energy saving. With a by-pass contactor you can reduce the power losses during normal run by 90 % or more.

The smaller units, PST30 up to PST300, which are not equipped with a built-in by-pass contactor, have an extra set of three terminals on the line side. The terminals are marked B1, B2 and B3 and shall be used when connecting an external by-pass contactor. This will enable the integrated protection functions also when the softstarter is by-passed.



### Fieldbus communication

The PST Softstarter has a built-in interface on the front for connection of the ABB FieldBusPlug used for fieldbus communication. Through this interface it is possible to control the softstarter, achieve status information, up- and down load of parameters. The interface between the softstarter and the FieldBusPlug is always the same. Independently of PST Softstarter size or delivery date it is possible to connect to any fieldbus protocol later on since this is defined in the FieldBusPlug itself. As a start, AS-Interface, DeviceNet and Profibus DP are available. To connect the PST Softstarter to a fieldbus system you need the accessories described on page 23 to 25 as well as specific software for PLC set-up, which is available at [www.abb.com/lowvoltage](http://www.abb.com/lowvoltage) on the Softstarter pages.



PSTB1050 with integrated by-pass contactor.

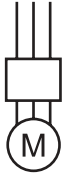

# PST30 ... 300 and PSTB370 ... 1050

For normal starts, class 10. In-Line

**How to select correct size for heavy duty starts**

See the quick guide on page 16.

## Ordering details In-Line

### PST30 ... PST300

#### 230 – 600 V

Supply voltage 100...250 V, 50/60 Hz

##### Motor power

400 V $P_e$ kW	500 V $P_e$ kW	690 V $P_e$ kW	Rated motor current, $I_e$ A	Type	Order code	Weight kg
15	18.5	-	30	PST30-600-70	1SFA 894 002 R7000	4.8
18.5	22	-	37	PST37-600-70	1SFA 894 003 R7000	4.8
22	25	-	44	PST44-600-70	1SFA 894 004 R7000	4.8
25	30	-	50	PST50-600-70	1SFA 894 005 R7000	4.8
30	37	-	60	PST60-600-70	1SFA 894 006 R7000	5.0
37	45	-	72	PST72-600-70	1SFA 894 007 R7000	5.0
45	55	-	85	PST85-600-70	1SFA 894 008 R7000	11.2
55	75	-	105	PST105-600-70	1SFA 894 009 R7000	13.0
75	90	-	142	PST142-600-70	1SFA 894 010 R7000	13.0
90	110	-	175	PST175-600-70	1SFA 894 011 R7000	21.5
110	132	-	210	PST210-600-70	1SFA 894 012 R7000	21.5
132	160	-	250	PST250-600-70	1SFA 894 013 R7000	23.0
160	200	-	300	PST300-600-70	1SFA 894 014 R7000	23.0

#### 400 – 690 V

Supply voltage 100...250 V, 50/60 Hz

##### Motor power

400 V $P_e$ kW	500 V $P_e$ kW	690 V $P_e$ kW	Rated motor current, $I_e$ A	Type	Order code	Weight kg
15	18.5	25	30	PST30-690-70	1SFA 895 002 R7000	4.8
18.5	22	30	37	PST37-690-70	1SFA 895 003 R7000	4.8
22	25	37	44	PST44-690-70	1SFA 895 004 R7000	4.8
25	30	45	50	PST50-690-70	1SFA 895 005 R7000	4.8
30	37	55	60	PST60-690-70	1SFA 895 006 R7000	5.0
37	45	59	72	PST72-690-70	1SFA 895 007 R7000	5.0
45	55	75	85	PST85-690-70	1SFA 895 008 R7000	11.2
55	75	90	105	PST105-690-70	1SFA 895 009 R7000	13.0
75	90	132	142	PST142-690-70	1SFA 895 010 R7000	13.0
90	110	160	175	PST175-690-70	1SFA 895 011 R7000	21.5
110	132	184	210	PST210-690-70	1SFA 895 012 R7000	21.5
132	160	220	250	PST250-690-70	1SFA 895 013 R7000	23.0
160	200	257	300	PST300-690-70	1SFA 895 014 R7000	23.0

### PSTB370 ... PSTB1050 with integrated by-pass

#### 230 – 600 V

Supply voltage 100...250 V, 50/60 Hz

##### Motor power

400 V $P_e$ kW	500 V $P_e$ kW	690 V $P_e$ kW	Rated motor current, $I_e$ A	Type	Order code	Weight kg
200	250	-	370	PSTB370-600-70	1SFA 894 015 R7000	31.0
250	315	-	470	PSTB470-600-70	1SFA 894 016 R7000	31.0
315	400	-	570	PSTB570-600-70	1SFA 894 017 R7000	52.0
400	500	-	720	PSTB720-600-70	1SFA 894 018 R7000	55.0
450	560	-	840	PSTB840-600-70	1SFA 894 019 R7000	60.0
560	730	-	1050	PSTB1050-600-70	1SFA 894 020 R7000	60.0

#### 400 – 690 V

Supply voltage 100...250 V, 50/60 Hz

##### Motor power

400 V $P_e$ kW	500 V $P_e$ kW	690 V $P_e$ kW	Rated motor current, $I_e$ A	Type	Order code	Weight kg
200	250	355	370	PSTB370-690-70	1SFA 895 015 R7000	31.0
250	315	450	470	PSTB470-690-70	1SFA 895 016 R7000	31.0
315	400	560	570	PSTB570-690-70	1SFA 895 017 R7000	52.0
400	500	710	720	PSTB720-690-70	1SFA 895 018 R7000	55.0
450	560	800	840	PSTB840-690-70	1SFA 895 019 R7000	60.0
560	730	965	1050	PSTB1050-690-70	1SFA 895 020 R7000	60.0



PST30...PST72

1SFC132017F0201



PST85...PST142

1SFC132018F0201



PST175...PST300

1SFC132015F0201



PSTB370...PSTB470

1SFC132018F0201



PSTB570...PSTB1050

1SFC132014F0201

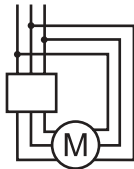

# PST30 ... 300 and PSTB370 ... 1050

For normal starts, class 10. Inside Delta

## Ordering details Inside Delta

**How to select correct size for heavy duty starts**

See the quick guide on page 16.

### PST30 ... PST300

#### 230 – 600 V

Supply voltage 100...250 V, 50/60 Hz

##### Motor power

400 V $P_e$ kW	500 V $P_e$ kW	690 V $P_e$ kW	Rated motor current, $I_e$ A	Type	Order code	Weight kg
25	30	-	52	PST30-600-70	1SFA 894 002 R7000	4.8
30	37	-	64	PST37-600-70	1SFA 894 003 R7000	4.8
37	45	-	76	PST44-600-70	1SFA 894 004 R7000	4.8
45	55	-	85	PST50-600-70	1SFA 894 005 R7000	4.8
55	75	-	105	PST60-600-70	1SFA 894 006 R7000	5.0
59	80	-	124	PST72-600-70	1SFA 894 007 R7000	5.0
75	90	-	147	PST85-600-70	1SFA 894 008 R7000	11.2
90	110	-	181	PST105-600-70	1SFA 894 009 R7000	13.0
132	160	-	245	PST142-600-70	1SFA 894 010 R7000	13.0
160	200	-	300	PST175-600-70	1SFA 894 011 R7000	21.5
184	250	-	360	PST210-600-70	1SFA 894 012 R7000	21.5
220	295	-	430	PST250-600-70	1SFA 894 013 R7000	23.0
257	355	-	515	PST300-600-70	1SFA 894 014 R7000	23.0

#### 400 – 690 V

Supply voltage 100...250 V, 50/60 Hz

##### Motor power

400 V $P_e$ kW	500 V $P_e$ kW	690 V $P_e$ kW	Rated motor current, $I_e$ A	Type	Order code	Weight kg
25	30	45	52	PST30-690-70	1SFA 895 002 R7000	4.8
30	37	55	64	PST37-690-70	1SFA 895 003 R7000	4.8
37	45	59	76	PST44-690-70	1SFA 895 004 R7000	4.8
45	55	75	90	PST50-690-70	1SFA 895 005 R7000	4.8
55	75	90	105	PST60-690-70	1SFA 895 006 R7000	5.0
59	80	110	124	PST72-690-70	1SFA 895 007 R7000	5.0
75	90	132	147	PST85-690-70	1SFA 895 008 R7000	11.2
90	110	160	181	PST105-690-70	1SFA 895 009 R7000	13.0
132	160	220	245	PST142-690-70	1SFA 895 010 R7000	13.0
160	200	257	300	PST175-690-70	1SFA 895 011 R7000	21.5
184	250	315	360	PST210-690-70	1SFA 895 012 R7000	21.5
220	295	400	430	PST250-690-70	1SFA 895 013 R7000	23.0
257	355	500	515	PST300-690-70	1SFA 895 014 R7000	23.0

### PSTB370...PSTB1050 with integrated by-pass

#### 230 – 600 V

Supply voltage 100...250 V, 50/60 Hz

##### Motor power

400 V $P_e$ kW	500 V $P_e$ kW	690 V $P_e$ kW	Rated motor current, $I_e$ A	Type	Order code	Weight kg
355	450	-	640	PSTB370-600-70	1SFA 894 015 R7000	31.0
450	600	-	814	PSTB470-600-70	1SFA 894 016 R7000	31.0
475	625	-	987	PSTB570-600-70	1SFA 894 017 R7000	52.0
670	880	-	1247	PSTB720-600-70	1SFA 894 018 R7000	55.0
780	1000	-	1455	PSTB840-600-70	1SFA 894 019 R7000	60.0
875	1150	-	1810	PSTB1050-600-70	1SFA 894 020 R7000	60.0

#### 400 – 690 V

Supply voltage 100...250 V, 50/60 Hz

##### Motor power

400 V $P_e$ kW	500 V $P_e$ kW	690 V $P_e$ kW	Rated motor current, $I_e$ A	Type	Order code	Weight kg
355	450	600	640	PSTB370-690-70	1SFA 895 015 R7000	31.0
450	600	800	814	PSTB470-690-70	1SFA 895 016 R7000	31.0
475	625	860	987	PSTB570-690-70	1SFA 895 017 R7000	52.0
670	880	1200	1247	PSTB720-690-70	1SFA 895 018 R7000	55.0
780	1000	1400	1455	PSTB840-690-70	1SFA 895 019 R7000	60.0
875	1150	1590	1810	PSTB1050-690-70	1SFA 895 020 R7000	60.0



PST30...PST72

1SFC132017F0201



PST85...PST142

1SFC132013F0201



PST175...PST300

1SFC132015F0201



PSTB370...PSTB470

1SFC132018F0201



PSTB570...PSTB1050

1SFC132014F0201

# Accessories for PST30 ... 300 and PSTB370 ... 1050

## Ordering details

### Cable connectors for Al and Cu cables

For PST85...300 you need 9 pieces if also using the terminals B1, B2, B3 for external by-pass contactor.

For softstarter type	Wire range mm <sup>2</sup>	Tightening torque max. Nm	Type	Order code	Pack <sup>ing</sup> piece	Weight kg 1 piece
PST85 ...142	6-120	16	-	1SDA 023 354 R0001	3	0.20
PST85 ...142	2 x (50-120)	16	LZ185-2C/120	1SFN 074 709 R1000	3	0.30
PST175 ...300	16-240	25	-	1SDA 023 368 R0001	3	0.40

### Cable connectors for Al and Cu cables

For PST85...300 you need 9 pieces if also using the terminals B1, B2, B3 for external by-pass contactor.

For softstarter type	Wire range mm <sup>2</sup>	Tightening torque max. Nm	Type	Order code	Pack <sup>ing</sup> piece	Weight kg 1 piece
PST85 ...142	35-95	13.5	-	1SDA 023 356 R0001	3	0.10
PST85 ...142	25-150	31	-	1SDA 023 357 R0001	3	0.10
PST175 ...300	120-240	43	-	1SDA 023 370 R0001	3	0.10

### Terminal extensions

For softstarter type	Dimensions hole ø mm <sup>2</sup>	bar mm	Type	Order code	Pack <sup>ing</sup> pieces	Weight kg 1 piece
PST85...142	8.5	17.5 x 5	LX185	1SFN 074 710 R1000	1	0.250
PST175...300	10.5	17.5 x 5	LX300	1SFN 075 110 R1000	1	0.350
PSTB370...470	10.5	25 x 5	LX400	1SFN 075 710 R1000	1	0.500
PSTB570...1050	13	40 x 6	LX750	1SFN 076 110 R1000	1	0.850

### Terminal enlargements

For softstarter type	Dimensions hole ø mm <sup>2</sup>	bar mm	Type	Order code	Pack <sup>ing</sup> pieces	Weight kg 1 piece
PST30...72	6.5	15 x 3	LW110	1SFN 074 307 R1000	1	0.100
PST85...142	10.5	17.5 x 5	LW185	1SFN 074 707 R1000	1	0.250
PST175...300	10.5	20 x 5	LW300	1SFN 075 107 R1000	1	0.450
PSTB370...470	10.5	25 x 5	LW460	1SFN 075 707 R1000	1	0.730
PSTB570...1050	13	40 x 6	LW750	1SFN 076 107 R1000	1	1.230

### Terminal nut washer

For softstarter type	Type	Order code	Pack <sup>ing</sup> piece	Weight kg 1 piece
PST85/147...142/245	LE185	1SFN 074 716 R1000	2	0.20
PST175/300...300/515	LE300	1SFN 075 116 R1000	2	0.30

### Terminal shrouds

For softstarter type	Req. qty	Type	Order code	Pack <sup>ing</sup> pieces	Weight kg 1 piece
PST85...142	1 pcs and	LT185-AC	1SFN 124 701 R1000	2	0.050
	1 pcs	LT460-AC	1SFN 125 701 R1000	2	0.100
PST85...142	1 pcs and	LT185-AL	1SFN 124 703 R1000	2	0.220
	1 pcs	LT460-AL	1SFN 125 703 R1000	2	0.800
PST175...300	3 pcs	LT300-AC	1SFN 125 101 R1000	2	0.070
PST175...300	3 pcs	LT300-AL	1SFN 125 103 R1000	2	0.280
PSTB370...470	2 pcs	LT460-AC	1SFN 125 701 R1000	2	0.100
PSTB370...470	2 pcs	LT460-AL	1SFN 125 703 R1000	2	0.800
PSTB570...1050	2 pcs	LT750-AC	1SFN 126 101 R1000	2	0.120
PSTB570...1050	2 pcs	LT750-AL	1SFN 126 103 R1000	2	0.825

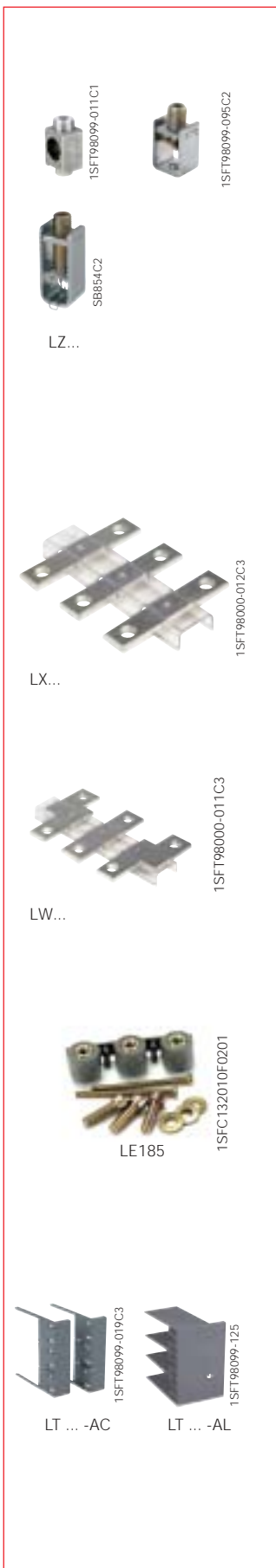



# FBP FieldBusPlug

## AS-Interface Fieldbus Connectors and Accessories



### AS-Interface FieldBusPlug Performance

Ready-made AS-Interface Slave fieldbus interface with various cable lengths.

- Applicable on all FBP motor starters and devices with max. 4 input signals and 3 output signals
- Degree of protection IP65, diagnostic LED

Designation FieldBusPlug	Cable length	Type	Order code	Pack <sup>ing</sup> pieces	Weight kg 1 piece
AS-Interface Performance	0.25 m	ASP22-FBP.025	1SAJ 220 000 R0003	1	0.09
AS-Interface Performance	0.50 m	ASP22-FBP.050	1SAJ 220 000 R0005	1	0.10
AS-Interface Performance	1.00 m	ASP22-FBP.100	1SAJ 220 000 R0010	1	0.13
AS-Interface Performance	5.00 m	ASP22-FBP.500	1SAJ 220 000 R0050	1	0.36

### Accessories for AS-Interface Bus Connection

#### AS-Interface Round Cable for Bus Junctions

Ready-made bus cable with an M12 connector and an open cable end.

- Application on bus junctions such as e.g. AS-Interface couplers or devices with an integrated AS-i interface

Designation	Cable length	Type	Order code	Pack <sup>ing</sup> pieces	Weight kg 1 piece
AS-Interface Round Cable with female connector	0.30 m	ASF11-FBP.030	1SAJ 922 002 R0003	1	0.04
AS-Interface Round Cable with male connector	0.30 m	ASM11-FBP.030	1SAJ 922 003 R0003	1	0.04

#### AS-Interface Round Cable for Bus Extension

Ready-made bus cable with M12 male and female connectors

Designation	Cable length	Type	Order code	Pack <sup>ing</sup> pieces	Weight kg 1 piece
AS-Interface Extension Cable	1.00 m	ASX11-FBP.100	1SAJ 922 001 R0010	1	0.08
AS-Interface Extension Cable	3.00 m	ASX11-FBP.300	1SAJ 922 001 R0030	1	0.20
AS-Interface Extension Cable	5.00 m	ASX11-FBP.500	1SAJ 922 001 R0050	1	0.31
AS-Interface Extension Cable	100 m	ASC11-FBP.999	1SAJ 922 004 R1000	1	5.60

#### AS-Interface Round Cable and Accessories for Bus Extension Bus cable and coupling accessories

Designation	Type	Order code	Pack <sup>ing</sup> pieces	Weight kg 1 piece
AS-Interface Round Cable, male conn.	ASM11-FBP.0	1SAJ 922 005 R0001	5	0.15
AS-Interface Round Cable, female conn.	ASF11-FBP.0	1SAJ 922 006 R0001	5	0.15
AS-Interface Flat-Cable Branch Circuit with M12 socket	AST11-FBP.0	1SAJ 922 007 R0001	1	0.15

#### AS-Interface Addressing Device, Power Unit, miscellaneous accessories

Designation FieldBusPlug	Type	Order code	Pack <sup>ing</sup> pieces	Weight kg 1 piece
AS-Interface Addr. Device, including plug-in power unit	ASA21-FBP.0	1SAJ 922 010 R0001	1	0.56
Power Unit PS 24V/5A, adjustable	Systron PS24/5	2 423 416 01	1	0.58
Address Signs for FieldBusPlug	CAL11-FBP.0	1SAJ 929 005 R0001	400	0.15



# FBP FieldBusPlug

## DeviceNet Fieldbus Connectors and Accessories

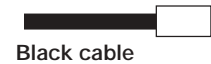

### DeviceNet FieldBusPlug

Ready-made DeviceNet fieldbus interface with various cable lengths.

- Applicable on all FBP motor starters and other devices
- Degree of protection IP65, diagnostic LED

Designation	Cable length	Type	Order code	Pack <sup>ing</sup> pieces	Weight kg 1 piece
DeviceNet FieldBusPlug					
DeviceNet	0.25 m	DNP21-FBP.025	1SAJ 230 000 R0003	1	0.09
DeviceNet	0.50 m	DNP21-FBP.050	1SAJ 230 000 R0005	1	0.10
DeviceNet	1.00 m	DNP21-FBP.100	1SAJ 230 000 R0010	1	0.13
DeviceNet	5.00 m	DNP21-FBP.500	1SAJ 230 000 R0050	1	0.36

### Accessories for the DeviceNet Bus Connector

#### DeviceNet round cable for bus junctions

Ready-made bus cable with an M12 connector and an open cable end.

- Application on bus junctions such as e.g. DeviceNet couplers or devices with an integrated DeviceNet interface

Designation	Cable length	Type	Order code	Pack <sup>ing</sup> pieces	Weight kg 1 piece
DeviceNet Round Cable with female connector	0.50 m	DNF11-FBP.050	1SAJ 923 002 R0005	1	0.04
DeviceNet Round Cable with male connector	0.50 m	DNM11-FBP.050	1SAJ 923 003 R0005	1	0.04

#### DeviceNet Round Cable for Bus Extension

Ready-made bus cable with M12 male and female connectors

Designation	Cable length	Type	Order code	Pack <sup>ing</sup> pieces	Weight kg 1 piece
DeviceNet Extension Cable	1.00 m	DNX11-FBP.100	1SAJ 923 001 R0010	1	0.08
DeviceNet Extension Cable	3.00 m	DNX11-FBP.300	1SAJ 923 001 R0030	1	0.20
DeviceNet Extension Cable	5.00 m	DNX11-FBP.500	1SAJ 923 001 R0050	1	0.31
Device Net Round Cable	100 m	DNC11-FBP.999	1SAJ 923 004 R0001	1	5.6

#### DeviceNet Round Cable and Accessories for Bus Extension Bus cable and coupling accessories

Designation	Cable length	Type	Order code	Pack <sup>ing</sup> pieces	Weight kg 1 piece
Device Net Round Cable Male Connector		DNM11-FBP.0	1SAJ 923 005 R0001	5	0.15
Device Net Round Cable Female Connector		DNF11-FBP.0	1SAJ 923 006 R0001	5	0.15

#### Termination Resistor, Power Unit, Miscellaneous Accessories

Designation	Type	Order code	Pack <sup>ing</sup> pieces	Weight kg 1 piece
Device Net Termination Resistor, 120 Ohm	DNR11-FBP.120	1SAJ 923 007 R0001	1	0.02
Power Unit PS 24 V/5 A, adjustable	Systron PS24/5	2 423 416 01	1	0.58

#### To connect the PST Softstarter to a DeviceNet fieldbus system...

you need specific software for PLC set-up, (EDS file) which is available at [www.abb.com/lowvoltage](http://www.abb.com/lowvoltage) on the Softstarter pages. Look under the documentation-link named Software. If you need help or advice, please contact your local ABB office.



# FBP FieldBusPlug

## Profibus DP Fieldbus Connectors and Accessories

Lilac cable

### Profibus DP FieldBusPlug

Ready-made Profibus DP fieldbus interface with various cable lengths.

- Applicable on all FBP motor starters and other devices
- Degree of protection IP65, diagnostic LED

Designation	Cable length	Type	Order code	Pack <sup>ing</sup> pieces	Weight kg
Profibus DP-FBP	0.25 m	PDP21-FBP.025	1SAJ 240 000 R0003	1	0.09
Profibus DP-FBP	0.50 m	PDP21-FBP.050	1SAJ 240 000 R0005	1	0.10
Profibus DP-FBP	1.00 m	PDP21-FBP.100	1SAJ 240 000 R0010	1	0.13
Profibus DP-FBP	5.00 m	PDP21-FBP.500	1SAJ 240 000 R0050	1	0.36

### Accessories for the Profibus DP Bus Connector

#### Profibus DP Round Cable for Bus Junctions

Ready-made bus cable with an M12 connector and an open cable end.

- Application on bus junctions such as e.g. Profibus DB couplers or devices with an integrated Profibus DB interface

Designation	Cable length	Type	Order code	Pack <sup>ing</sup> pieces	Weight kg
Profibus DP Round Cable with female connector	0.50 m	PDF11-FBP.050	1SAJ 924 002 R0005	1	0.04
Profibus DP Round Cable with male connector	0.50 m	PDM11-FBP.050	1SAJ 924 003 R0005	1	0.04

#### Profibus DP Round Cable for Bus Extension

Ready-made bus cable with M12 male and female connectors

Designation	Cable length	Type	Order code	Pack <sup>ing</sup> pieces	Weight kg
Profibus DP Extension Cable	1.00 m	PDX11-FBP.100	1SAJ 924 001 R0010	1	0.08
Profibus DP Extension Cable	3.00 m	PDX11-FBP.300	1SAJ 924 001 R0030	1	0.20
Profibus DP Extension Cable	5.00 m	PDX11-FBP.500	1SAJ 924 001 R0050	1	0.31
Profibus DP Extension Cable	100 m	PDX11-FBP.500	1SAJ 924 001 R1000	1	5.60

#### Profibus DP Accessories for Bus Extension

Designation	Type	Order code	Pack <sup>ing</sup> pieces	Weight kg
Profibus DP Male Connector	PDM11-FBP.0	1SAJ 924 005 R0001	5	0.03
Profibus DP Female Connector	PDF11-FBP.0	1SAJ 924 006 R0001	5	0.03

#### Profibus DP Termination Resistor, Miscellaneous Accessories

Designation	Type	Order code	Pack <sup>ing</sup> pieces	Weight kg
Profibus DP Termination resistor, 120 ohm	PDR11-FBP.120	1SAJ 925 005 R0001	1	0.02

#### To connect the PST Softstarter to a Profibus DP fieldbus system...

you need specific software for PLC set-up, (GSD file) which is available at [www.abb.com/lowvoltage](http://www.abb.com/lowvoltage) on the Softstarter pages. Look under the documentation-link named Software. If you need help or advice, please contact your local ABB office.



# PST30 ... 300 and PSTB370 ... 1050

## Technical data/Settings

	PST30 ... 300	PSTB370 ... 1050		PST30 ... 300	PSTB370 ... 1050	
<b>Rated insulation voltage <math>U_i</math></b>	690 V	690 V	<b>Control circuit /Hardware inputs</b>	Internal 24 V DC (10 mA closed)	Yes	Yes
<b>Rated operational voltage <math>U_e</math></b>	208 ... 690 V	208 ... 690 V		Start / Stop inputs	Yes	Yes
<b>Starting capacity</b> at max rated current $I_r$	3 x $I_r$ for 15 sec.	3 x $I_r$ for 15 sec.	Two extra programmable inputs <i>(Each input can be programmed to be Non or Reset or Enable or Jog or DOL- On or Start motor 2 (or 3)).</i>	Yes	Yes	
<b>Number of starts per hour</b>	30 <sup>1)</sup>	10 <sup>1)</sup>	<b>Signal indication LED's</b>			
<b>Overload capability</b> Overload Class	10	10	Power on – Green	Yes	Yes	
<b>Service factor</b>	115 %	115 % (PSTB370... PSTB840) 100 % (PSTB1050)	Fault - Red	Yes	Yes	
<b>Ambient temperature</b> During operation	±0 ... +50 °C <sup>2)</sup>	±0 ... +50 °C <sup>2)</sup>	Protection - Yellow	Yes	Yes	
During storage	-25... +70 °C	-25... +70 °C	<b>Protections</b>			
<b>Altitudes</b> Maximum altitude	4000 m <sup>3)</sup>	4000 m <sup>3)</sup>	Electronic overload	Yes	Yes	
<b>Degree of protection</b> Main circuit	IP10 (PST30 ... 72) IP00 (PST85 ... 300)	IP00 (all)	Adjustable tripping classes - Class 10 A, 10, 20 and 30	Yes	Yes	
Supply and Control circuit	IP20	IP20	Dual ramp (separate overload function for start and run)	Yes	Yes	
<b>Main circuit</b> Built in By-pass contactor	No	Yes	PTC connection	Yes	Yes	
Cooling system - Fan cooled <i>(thermostat controlled)</i>	Yes	Yes	Locked rotor protection	Yes	Yes	
<b>Supply circuit</b> Supply voltage – one range	100 ... 250 V, 50/60 Hz +10 %/-15 %	100 ... 250 V 50/60 Hz +10 %/-15 %	Underload protection	Yes	Yes	
<b>HMI for settings</b> <i>(Human Machine Interface)</i> 20 segment display	Yes	Yes	Phase imbalance	Yes	Yes	
Keypad with two selection keys and two navigating keys	Yes	Yes	High current (8 x $I_e$ )	Yes	Yes	
Plain text in 10 languages <i>(English, German, Italian, Chinese, Finnish, Swedish, French, Spanish, Dutch and Portuguese)</i>	Yes	Yes	Phase reversal protection	Yes	Yes	
<b>Signal relays</b> Number of programmable signal relays <i>(Each relay can be programmed to be Run, By-pass or Event signal)</i>	3	3	<b>Warnings (pre-warning)</b>			
K4 – Default as Run signal	Yes	Yes	High current	Yes	Yes	
K5 – Default as By-pass signal	Yes	Yes	Low current (underload)	Yes	Yes	
K6 – Default as Event signal	Yes	Yes	Overload trip	Yes	Yes	
Rated operational voltage $U_e$	250 V	250 V	Overtemp. thyristors (SCR)	Yes	Yes	
Rated thermal current $I_{th}$	5 A	5 A	<b>Start of several motors</b> Possible to set up and start three different motors	Yes	Yes	
Rated operational current $I_e$ at AC-15 ( $U_e = 250$ V)	1.5 A	1.5 A	<b>Field bus connection</b> Connection for ABB FielBusPlug	Yes	Yes	
			AS-Interface (option cable)	Yes	Yes	
			DeviceNet (option cable)	Yes	Yes	
			Profibus DP (option cable)	Yes	Yes	

<sup>1)</sup> Valid for 50 % on time and 50 % off time, with 3.5 x  $I_e$  for 7 seconds. If other data is required, please contact your sales office

<sup>2)</sup> Above 40 °C up to max. 50 °C reduce the rated current with 0.8 % per °C.

<sup>3)</sup> When used at high altitudes above 1000 meters up to 4000 meters you need to derate rated current using the following formula.

$$[\% \text{ of } I_e = 100 - \frac{x - 1000}{150}]$$

x = actual altitude for the softstarter

## Major possible settings and the displayed text and the set default values

Description	Text on display (Eng)	Values on display	Default value
Setting current for overload, locked rotor etc.	Setting $I_e$	9,0 ... 1380 A divided into 19 overlapping ranges.	See table, page 29
Time for start ramp	Start Ramp	1 ... 30 s, 1 ... 120 s (Range depends on Start Range)	10 s
Time for stop ramp	Stop Ramp	0 ... 30 s, 0 ... 120 s (Range depends on Stop Range)	0 s
Initial voltage for start ramp	Init Volt	30 ... 70 %	30 %
End voltage for stop ramp	End Volt	30 ... 70 %	30 %
Step down voltage	Step Down	30 ... 100 %	100 %
Level of the current limit.	Current Lim	2,0 ... 5,0 x $I_e$	4,0 x $I_e$
Selection of Kick start	Kick Start	Yes, No	No
Level of Kick start if selected	Kick Level	50 ... 100 %	50 %
Time for Kick start if selected	Kick Time	0,1 ... 1,5 s	0,2

cont.

# PST30 ... 300 and PSTB370 ... 1050

## Technical data/Settings

Cont. Major possible settings and the displayed text and the set default values

Description	Text on display (Eng)	Values on display	Default value
Selectable range for start ramp	Start Range	1 ... 30 s, 1...120 s	1 ... 30 s
Selectable range for stop ramp	Stop Range	0 ... 30 s, 0 ... 120 s	0 ... 30 s
Overload protection	Overload	No, Normal, Dual	Normal
Overload Class	OL Class	10A, 10, 20, 30	10
Overload Class, Dual type, Start Class	OL Class S	10A, 10, 20, 30	10
Overload Class, Dual type, Run Class	OL Class R	10A, 10, 20, 30	10
Type of operation for overload protection	OL Op	Stop-M, Stop-A, Ind	Stop-M
Locked rotor protection	Locked Rotor	Yes, No	No
Trip level for locked rotor protection	Lock R Lev	3,0 ... 8,0 x $I_e$	4,0 x $I_e$
Trip time for locked rotor protection	Lock R Time	0,2 ... 10 s	1,0 s
Type of operation for locked rotor protection	Lock R Op	Stop-M, Stop-A, Ind	Stop-M
Underload protection	Underload	Yes, No	No
Trip level for Underload protection	Underl Lev	0,4 ... 0,8 x $I_e$	0,8 x $I_e$
Trip time for Underload protection	Underl Time	1...30 s	10 s
Type of operation for Underload protection	Underl Op	Stop-M, Stop-A, Ind	Stop-M
Phase imbalance protection	Phase Imb	Yes, No	No
Trip level for phase imbalance protection	Ph Imb Lev	10...80 %	80 %
Type of operation for phase imbalance protection	Ph Imb Op	Stop-M, Stop-A, Ind	Stop-M
High current protection	High I	Yes, No	No
Type of operation for high current protection	High I Op	Stop-M, Stop-A, Ind	Stop-M
Phase reversal protection	Phase Rev	Yes, No	No
Type of operation for phase reversal protection	Ph Rev Op	Stop-M, Stop-A, Ind	Stop-M
PTC protection	PTC	Yes, No	No
Type of operation for PTC protection	PTC Op	Stop-M, Stop-A	Stop-M
An external Bypass contactor is used	Ext ByPass	Yes, No	No
High current warning	Warn I=High	Yes, No	No
Trip level for high current warning	Wa I=H Lev	0,5 ... 5,0 x $I_e$	1,2 x $I_e$
Low current warning	Warn I=Low	Yes, No	No
Trip level for low current warning	Wa I=L Lev	0,4 ... 1,0 x $I_e$	0,5 x $I_e$
Overload warning	Warn OL	Yes, No	No
Trip level for overload warning	Wa OL Lev	40...99 %	90 %
Thyristor overload warning	Warn SCR OL	Yes, No	Yes
Type of operation for phase loss fault	Ph Loss Op	Stop-M, Stop-A	Stop-M
Type of operation for by-pass fault	BP Fault Op	Stop-M, Stop-A, Ind	Stop-M
Type of operation for fieldbus fault	FB Fault Op	Stop-M, Stop-A	Stop-M
Type of operation for frequency fault	Freq F Op	Stop-M, Stop-A	Stop-M
Type of operation for heat sink over temperature fault	HS Temp Op	Stop-M, Stop-A	Stop-M
Type of operation for thyristor short circuit fault	SCR SC Op	Stop-M, Stop-A	Stop-M
Function of programmable input In_0	In0	None, Reset, Enable, Jog, DOL, Start 2	Reset
Function of programmable input In_1	In1	None, Reset, Enable, Jog, DOL, Start 3	Reset
Function of programmable relay output K4	Relay K4	Run, TOR, Event	Run
Function of programmable relay output K5	Relay K5	Run, TOR, Event	TOR
Function of programmable relay output K6	Relay K6	Run, TOR, Event	Event
Control of the softstarter with fieldbus	Fieldb Ctrl	Yes, No	No
Number of sequences for sequence start.	No of Seq	No, 2, 3	No
1 <sup>st</sup> sequence, time for start ramp	Start Ramp1	1...30 s, 1...120 s (Range depends on Start Range)	10 s
1 <sup>st</sup> sequence, initial voltage for start ramp	Init Volt1	30...70 %	30 %
1 <sup>st</sup> sequence, current limit	Curr Lim1	2,0 ... 5,0 x $I_e$	4,0 x $I_e$
1 <sup>st</sup> sequence, setting current	1st Set Ie	9,0 ... 1380 A divided into 19 overlapping ranges	See table, page 29
2 <sup>nd</sup> sequence, time for start ramp	Start Ramp2	1...30 s, 1...120 s (Range depends on Start Range)	10 s
2 <sup>nd</sup> sequence, initial voltage for start ramp	Init Volt2	30...70 %	30 %
2 <sup>nd</sup> sequence, current limit	Curr Lim2	2,0 ... 5,0 x $I_e$	4,0 x $I_e$
2 <sup>nd</sup> sequence, setting current	2nd Set Ie	9,0 ... 1380 A divided into 19 overlapping ranges	See table, page 29
3 <sup>rd</sup> sequence, time for start ramp	Start Ramp3	1...30 s, 1...120 s (Range depends on Start Range)	10 s
3 <sup>rd</sup> sequence, initial voltage for start ramp	Init Volt3	30 ... 70 %	30 %
3 <sup>rd</sup> sequence, current limit	Curr Lim3	2,0 ... 5,0 x $I_e$	4,0 x $I_e$
3 <sup>rd</sup> sequence, setting current	3rd Set Ie	9,0 ... 1380 A divided into 19 overlapping ranges	See table, page 29
Language to use on display	Language	US/UK, FI, SE, PT, NL, IT, FR, ES, DE, CN	US/UK
Time for display automatic turn off	LCD Auto Off	1 ... 255 min	15 min
Password for display	Password	No, 1 ... 255	1
Type of date presentation	Date Type	ISO, CE, US	ISO
Year	Date Year	2001...2060	Individual
Month	Date Month	1 ...12	Individual
Day	Date Day	1 ... 31	Individual
Hour	Time Hour	0 ... 23	Individual
Minutes	Time Min	0 ... 59	Individual

# PST30 ... 300 and PSTB370 ... 1050

## Technical data/Settings

### Tripping curves for the integrated electronic overload

All units have an integrated electronic overload possible to set on four different tripping classes. Below you find a curve for each tripping class in cold state.

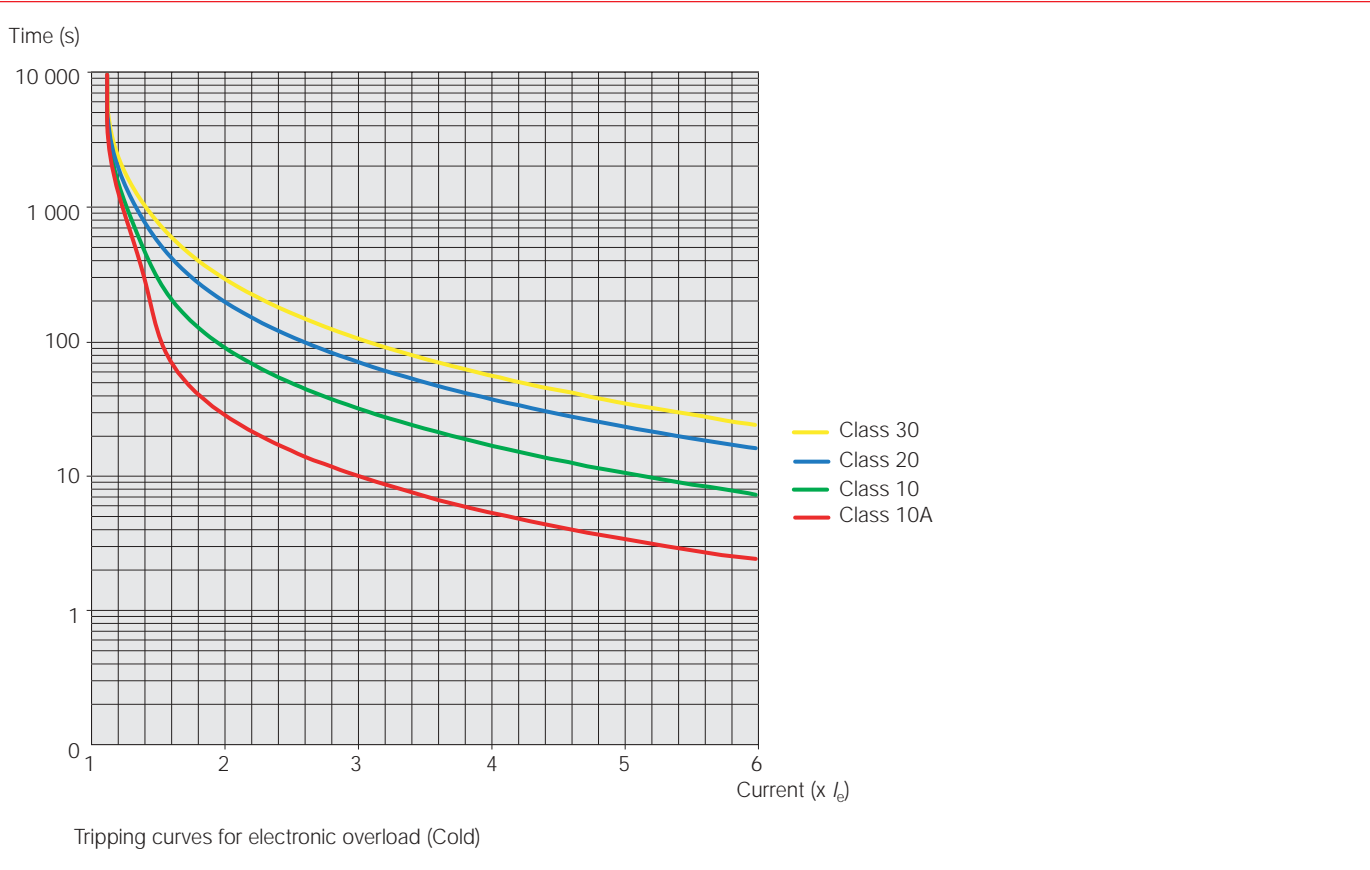

### ABB FieldBusPlug

#### Controlling possibilities when using different field buses

	AS-Interface	DeviceNet	Profibus DP
Simple control (start/stop etc)	X	X	X
Complete control	-	X	X
Simple status information	X	X	X
Detailed status information	-	X	X
Possibilities to write parameters	-	X	X
Possibilities to read parameters	-	X	-

For more detailed information, please see the Installation and Commissioning manual available at [www.abb.com/lowvoltage](http://www.abb.com/lowvoltage) on the Softstarter pages.

# PST30 ... 300 and PSTB370 ... 1050

## Technical data/Settings

### Cross section of connectable cables

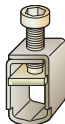
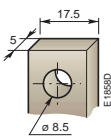
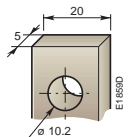
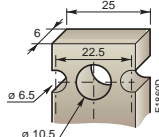
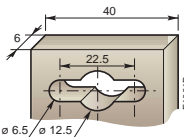
		Type of softstarter				
		PST30 ... 72	PST85 ... 142	PST175 ... 300	PSTB370 ... 470	PSTB570 ... 1050
<b>Main circuit</b>						
Available terminals:	L1, L2, L3	Yes	Yes	Yes	Yes	Yes
	T1, T2, T3	Yes	Yes	Yes	Yes	Yes
(For external by-pass):	B1, B2, B3	Yes	Yes	Yes	No	No
Connection clamp						
						
	Solid/Stranded	1 x mm <sup>2</sup>	10 ... 95	See accessories	See accessories	-
	Solid/Stranded	1 x mm <sup>2</sup>	6 ... 35	See accessories	See accessories	-
	Tightening torque (recommended), Nm		6.0	See accessories	See accessories	-
Connection bar						
No						
	Width and thickness	mm	-			
	Hole diameter	mm	-			
	Tightening torque (recommended), Nm	-	9	18	40	49
<b>Supply and control circuit</b>						
Connection clamp		Yes	Yes	Yes	Yes	Yes
	Solid/Stranded	1 x mm <sup>2</sup>	2.5	2.5	2.5	2.5
	Solid/Stranded	1 x mm <sup>2</sup>	1.5	1.5	1.5	1.5
	Tightening torque (recommended), Nm	0.5	0.5	0.5	0.5	0.5

### Fuse ratings and power losses

For softstarter	Recommended ABB Overload protection Type	Current range A	Max power loss at rated I <sub>e</sub> W	Maximum fuse ratings - main circuit <sup>1)</sup>				Power requirements supply circuit	
				Bussmann fuses			Ferraz fuses		VA/VA pull in
				A	Type	Holder	A	Type	
<b>PST</b>									
PST30	Integrated	9...35	100	80	170M1366	170H1007	100	6,6 URB 000 D08V 0100	5
PST37	Integrated	12...46	120	125	170M1368	170H1007	160	6,6 URB 000 D08V 0160	5
PST44	Integrated	15...58	140	160	170M1369	170H1007	200	6,6 URD 30 D08A 0200	5
PST50	Integrated	15...58	160	160	170M1369	170H1007	200	6,6 URD 30 D08A 0200	5
PST60	Integrated	18...69	190	200	170M1370	170H1007	250	6,6 URD 30 D08A 0250	5
PST72	Integrated	23...86	230	250	170M1371	170H1007	315	6,6 URD 30 D08A 0315	5
PST85	Integrated	30...115	270	315	170M1372	170H1007	400	6,6 URD 30 D08A 0400	10
PST105	Integrated	38...144	325	400	170M3019	170H3004	400	6,6 URD 30 D08A 0400	10
PST142	Integrated	45...173	435	450	170M3020	170H3004	500	6,6 URD 30 D08A 0500	10
PST175	Integrated	60...230	540	500	170M3021	170H3004	550	6,6 URD 30 D08A 0550	15
PST210	Integrated	75...288	645	630	170M5012	170H3004	630	6,6 URD 31 D08A 0630	15
PST250	Integrated	75...288	765	700	170M5013	170H3004	630	6,6 URD 31 D08A 0630	15
PST300	Integrated	90...345	920	900	170M5015	170H3004	900	6,6 URD 31 D11A 0900	15
<b>PSTB 500V</b>									
PSTB370	Integrated	120...460	90	700	170M5013	170H3004	630	6,6 URD 31 D08A 0630	20/480
PSTB470	Integrated	150...575	110	900	170M5015	170H3004	900	6,6 URD 31 D11A 0900	20/480
PSTB570	Integrated	180...690	105	900	170M5015	170H3004	900	6,6 URD 31 D11A 0900	25/900
PSTB720	Integrated	225...863	110	1250	170M5018	170H3004	1250	6,6 URD 33 D11A 1250	25/860
PSTB840	Integrated	300...1160	170	1500	170M5018	170H3004	1600	6,6 URD 33 D11A 1250	25/860
PSTB1050	Integrated	360...1380	170	1800	170M6020	170H3004	2000	6,6 URD 33 PLAF 2000	25/860
<b>PSTB 690V</b>									
PSTB370	Integrated	120...460	90	700	170M5013	170H3004	630	6,6 URD 31 D08A 0630	20/480
PSTB470	Integrated	150...575	110	900	170M5015	170H3004	900	6,6 URD 31 D11A 0900	20/480
PSTB570	Integrated	180...690	105	900	170M5015	170H3004	900	6,6 URD 31 D11A 0900	25/900
PSTB720	Integrated	225...863	110	1250	170M6018	170H3004	1250	6,6 URD 33 D11A 1250	25/860
PSTB840	Integrated	300...1150	170	1500	170M6018	170H3004	1600	6,6 URD 33 TTFA 1600	25/860
PSTB1050	Integrated	360...1380	170	1600	170M6019	170H3004	1600	6,6 URD 33 TTFA 1600	25/860

<sup>1)</sup> For the supply circuit 6A delayed, for MCB use C characteristics.

# PSS03 ... PSS300/515

## Dimensions

### PSS03, PSS12

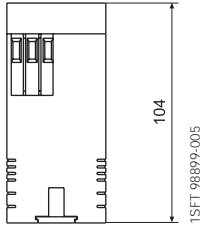

Depth from DIN rail 101 mm

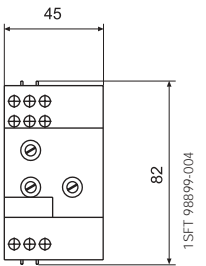

### PSS25

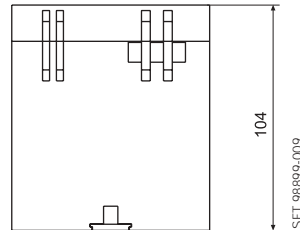

Depth from DIN rail 101 mm

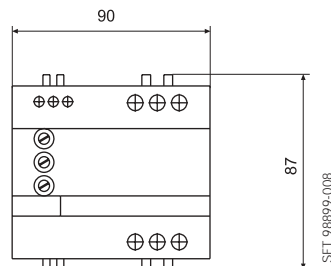

### PSS18/30-500 ... 44/76-500

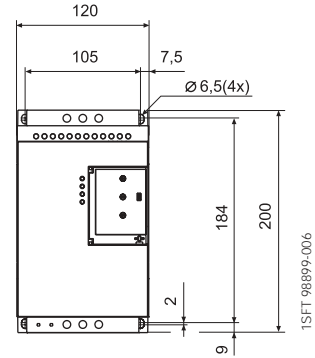
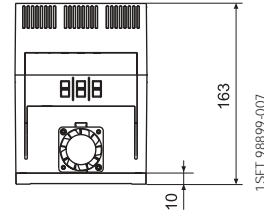

### PSS50/85-500 ... 72/124-500 PSS18/30-690 ... 72/124-690

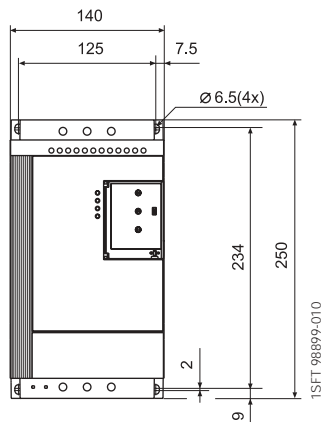
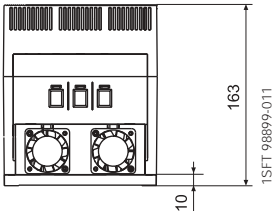

### PSS85/147-500 ... 142/245-500 PSS85/147-690 ... 142/245-690

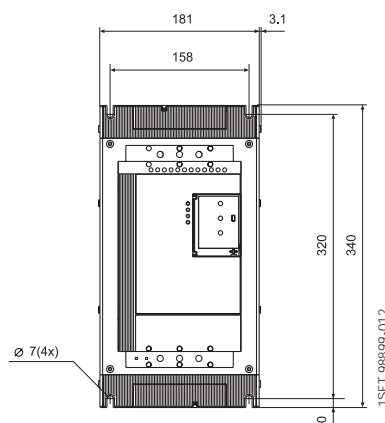
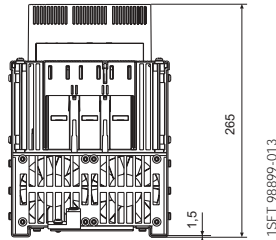

### PSS 175/300-500 ... 300/515-500 PSS 175/300-690 ... 300/515-690

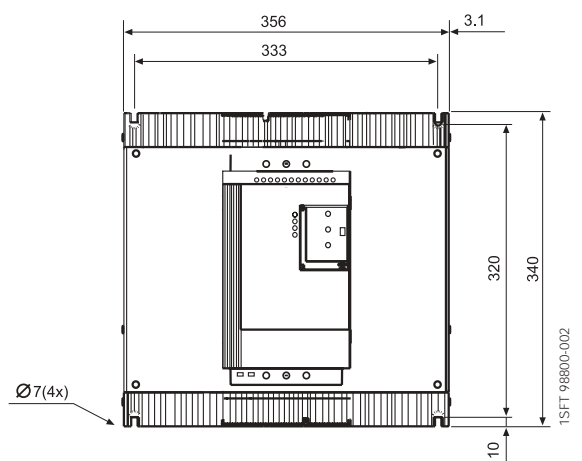
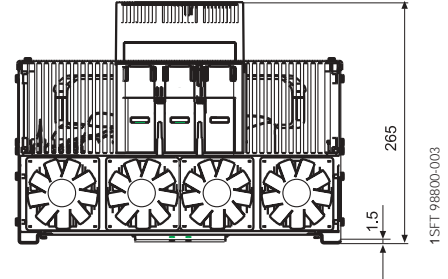

# PST30 ... 300 and PSTB370 ... 1050

## Dimensions

PST30 ... 72

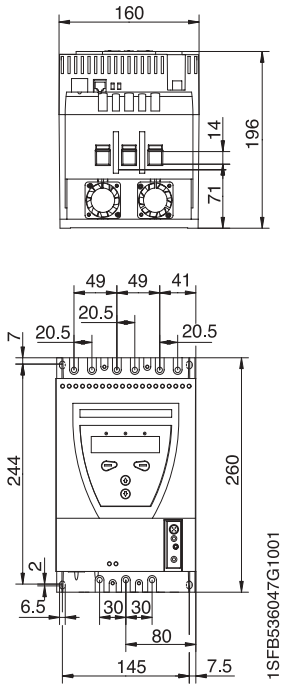

PST85 ...142

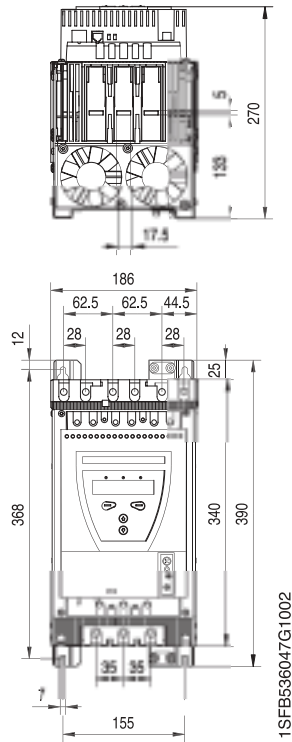

PST175 ... 300

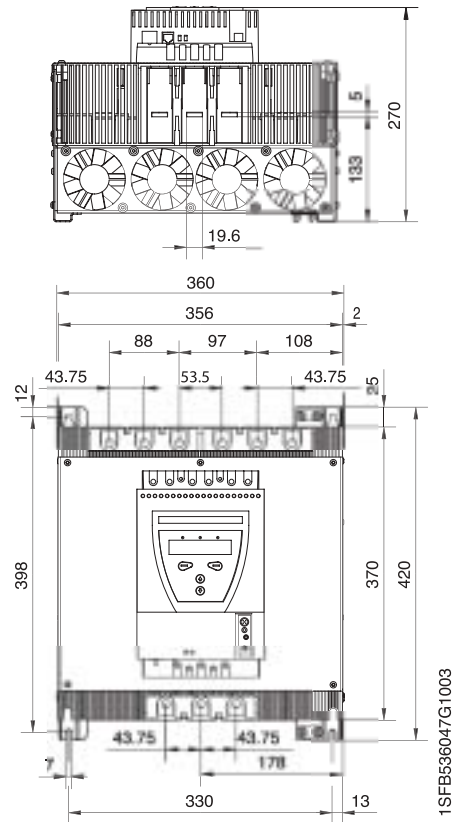

PSTB370 ... 470

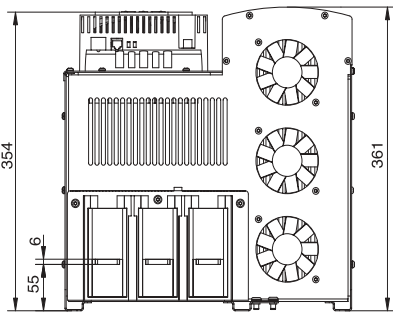

PSTB570 ... 1050

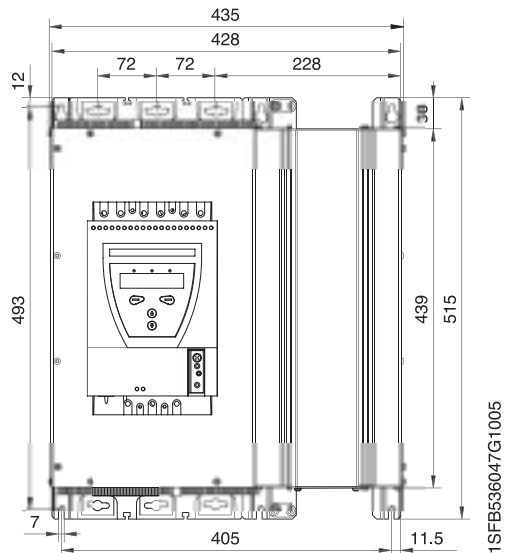
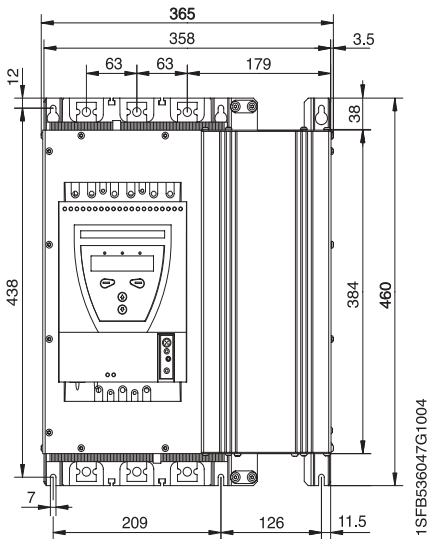
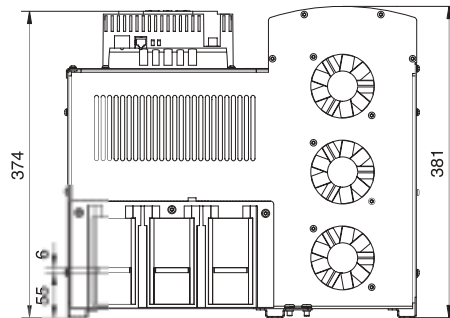

# PSS03 ... PSS300/515

## Circuit diagrams

### PSS03...25

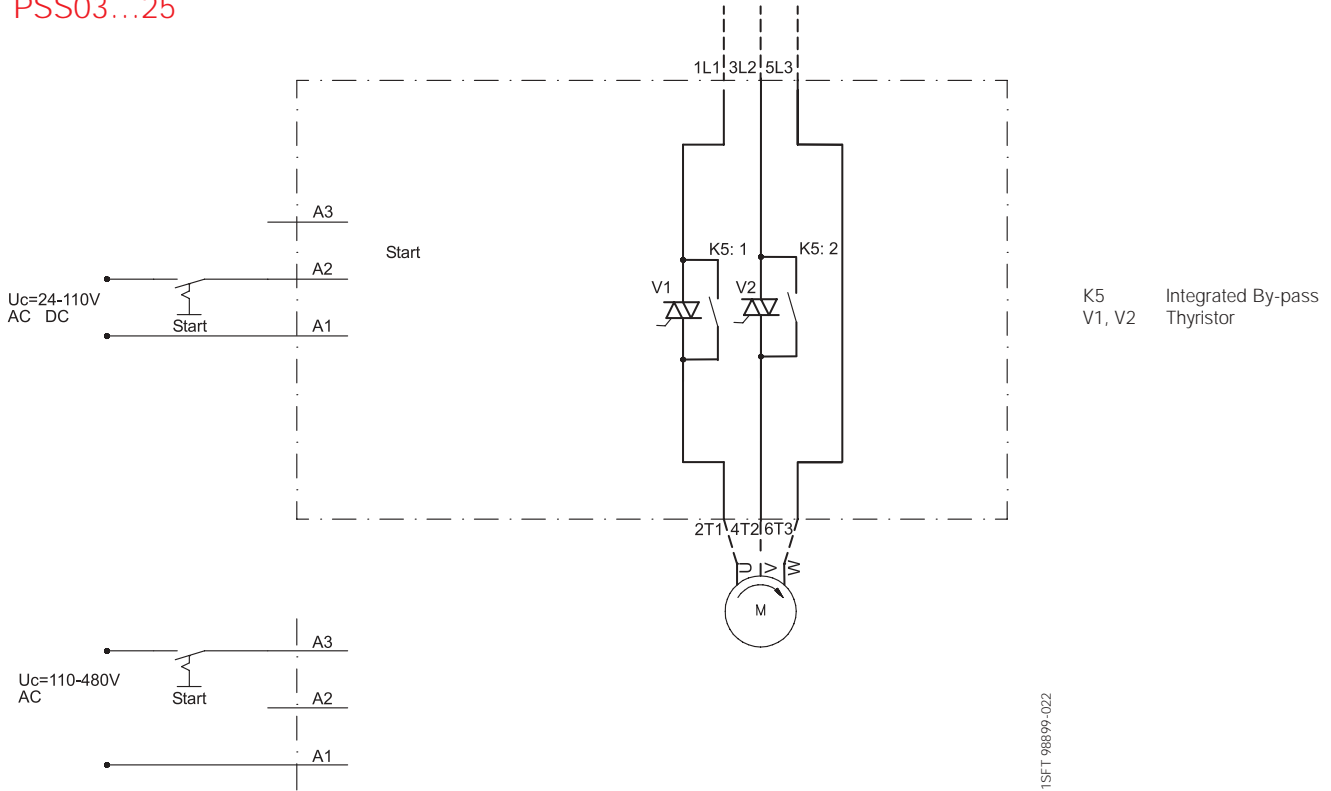

### PS S18/30...300/515

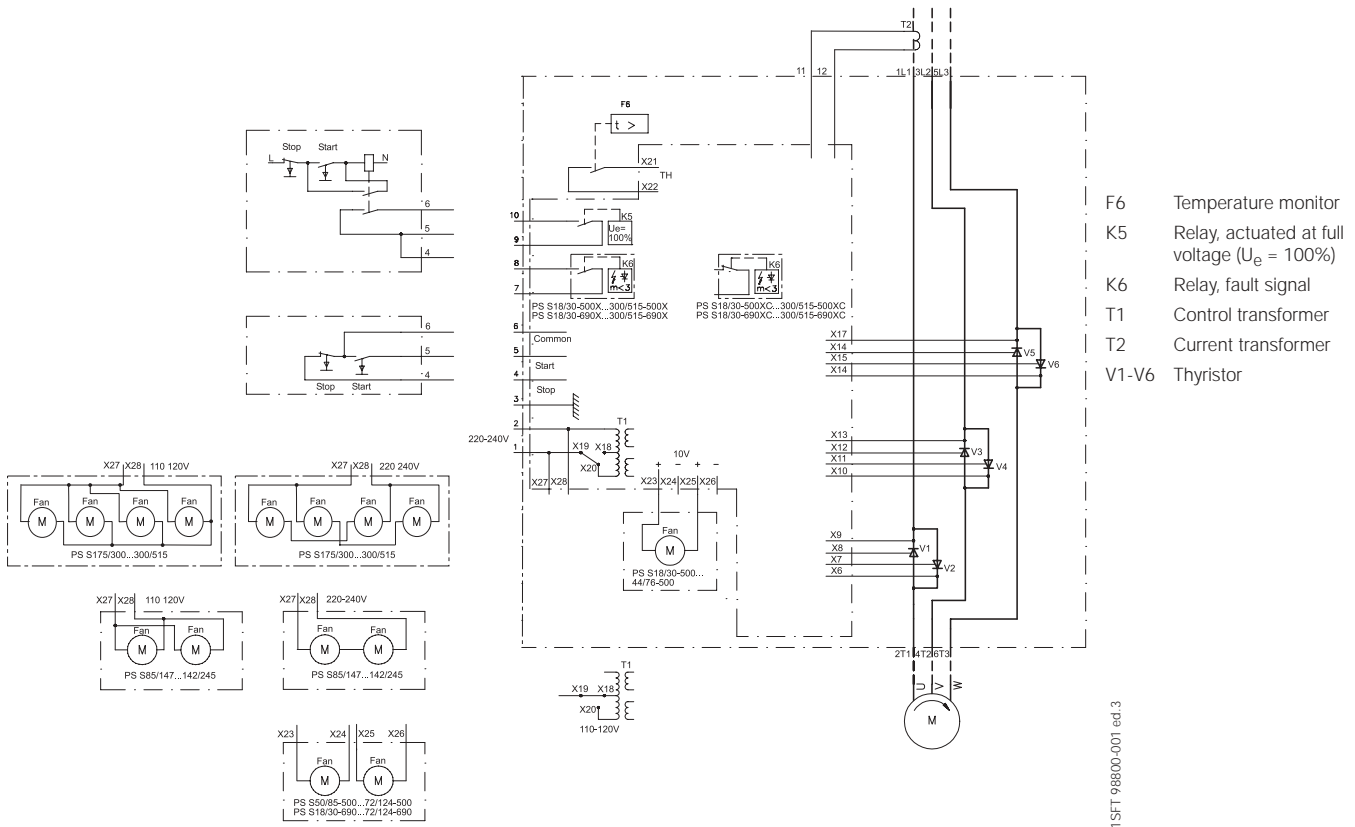

# PST30 ... 300 and PSTB370 ... 1050

## Circuit diagrams

### PST30...300

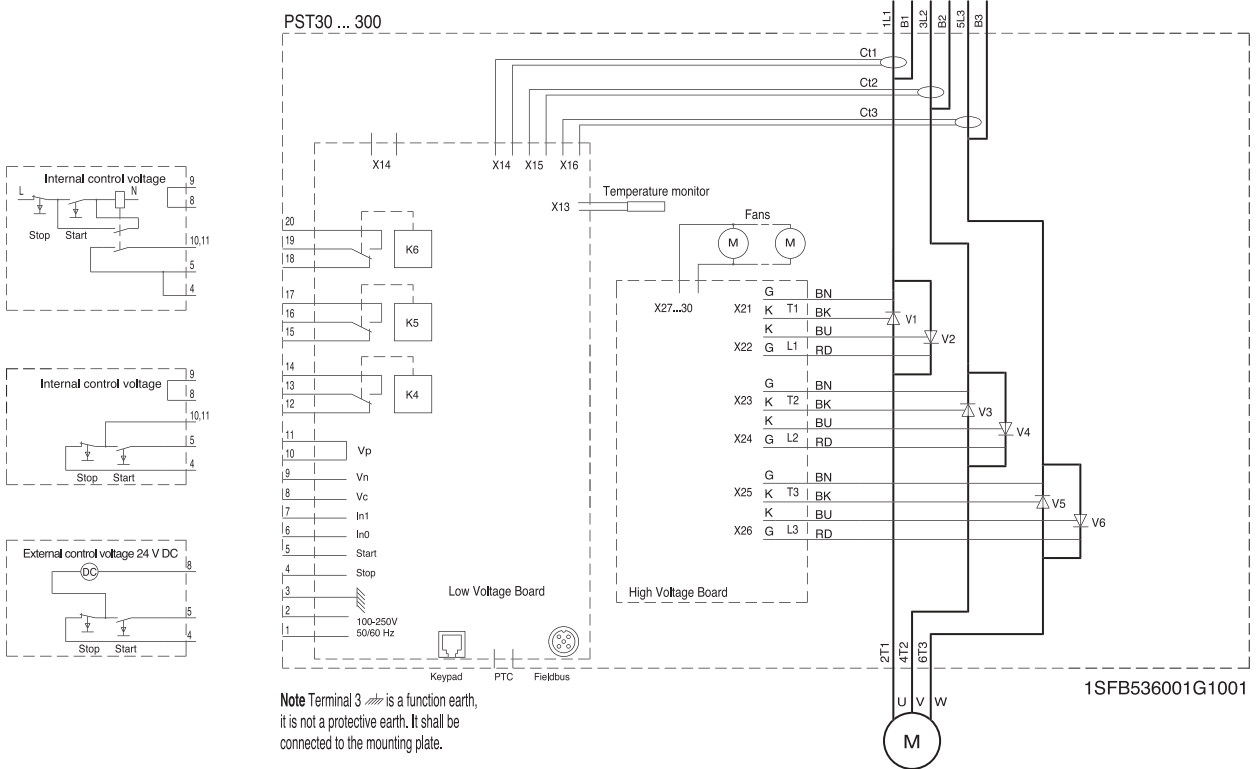

### PSTB370...1050

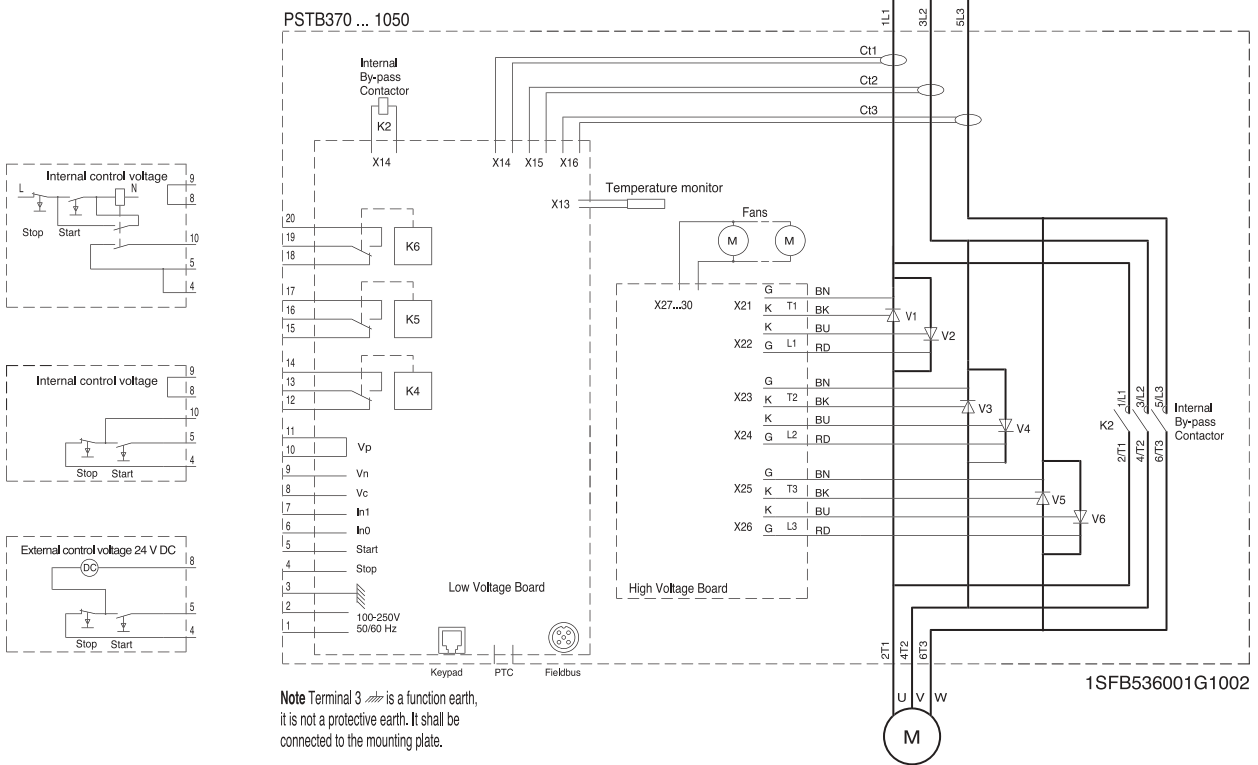

# PSS ... PST ... PSTB

## Wall mounting instruction

### Minimum distance to wall/front

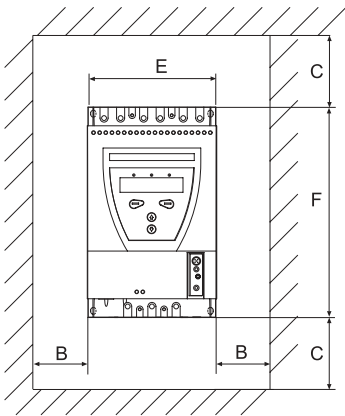
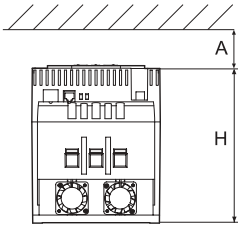

Softstarter type	Dimensions					
	A	B	C	E	F	H
<b>PSS_-500 for 500 V</b>						
PSS18/30 ... 44/76	20	10	100	120	200	163
PSS50/85 ... 72/124	20	10	100	140	250	163
PSS85/147 ... 142/245	20	10	100	181	340	265
PSS175/300 ... 300/515	20	10	100	356	340	265
<b>PSS_-690 for 690 V</b>						
PSS18/30 ... 72/124	20	10	100	140	250	163
PSS85/147 ... 142/245	20	10	100	181	340	265
PSS175/300 ... 300/515	20	10	100	356	340	265
<b>PST - all</b>						
PST30 ... 72	20	10	100	160	260	196
PST85 ... 300	20	10	100	186	390	270
PST175 ... 300	20	10	100	360	420	270
<b>PSTB - all</b>						
PSTB370 ... 470	20	15	150	365	460	361
PSTB570 ... 1050	20	15	150	435	515	381



