

Electronic timer relay CT-MVS

Multifunction timer relay with potential dependent control input

Data sheet

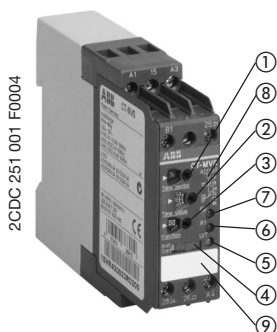

CT-MVS

- ① Time ranges - setting to the max. value of the time range
- ② Direct reading scale to set time value within chosen range
- ③ Selection of function
- ④ Change-over switch to set 2nd c/o contact as an instantaneous contact
- ⑤ U/T: green LED - supply voltage flashes whilst timing, glows steadily after timing
- ⑥ R1: red LED - output relay 1 energized
- ⑦ R2: red LED - output relay 2 energized
- ⑧ Circuit diagram
- ⑨ Marker label

Features

- 8 functions
- 10 time ranges from 0.05 s - 300 h in one unit
- Potential dependent control input
- 2 c/o contacts
- 2nd c/o contact selectable as instantaneous contact
- 3 LEDs for status indication

Approvals   (pending),  ¹⁾

Ordering data

Type	Supply voltage	Order Code
CT-MVS	24 V / 42-48 V AC/DC, 110-240 V AC	1SVR 430 023 R0200

Application

The multifunction timer relay CM-MVS is suited especially for service and maintenance tasks. If needed, it can replace a number of devices with different functions, voltage and time ranges.

Operating mode

The CM-MVS features 8 different functions, which can be selected by the front-face rotary switch ③, on which every function is shown with a characteristic, international sign, eg.  for ON-delay.

The 10 time ranges from 0.05 s - 300 h can also be selected by another front-face rotary switch ①. The desired time value is set by the front-face potentiometer with a direct reading scale ②. The green LED ⑤ flashes whilst timing.

Function diagrams

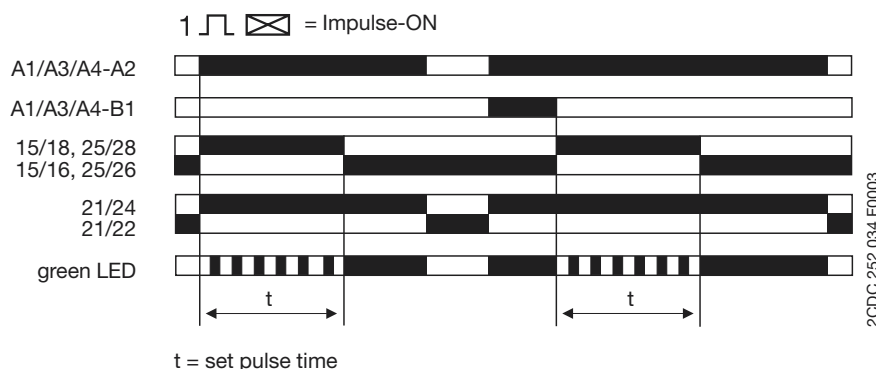
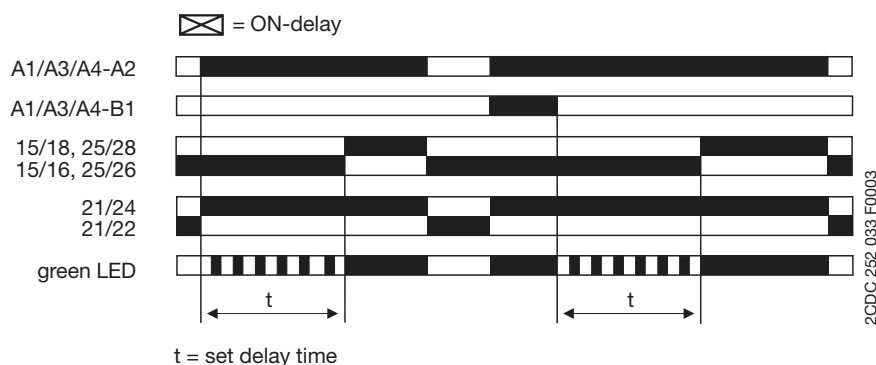

¹⁾ C-Tick (Australia, Newzealand)

Electronic timer relay CT-MVS

Multifunction timer relay with potential dependent control input

Data sheet

Function diagrams (continued)

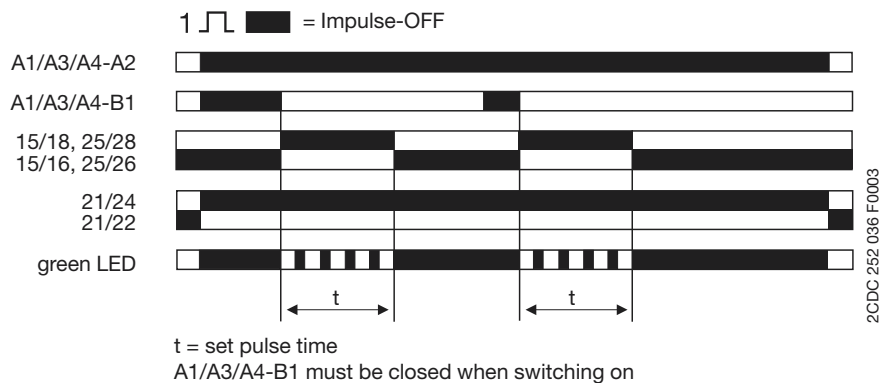
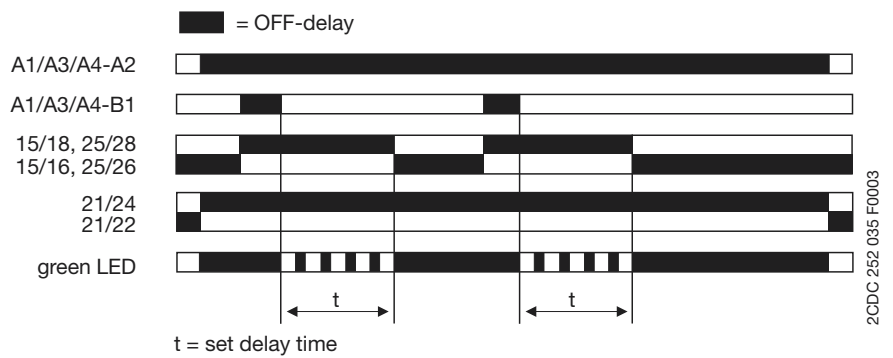
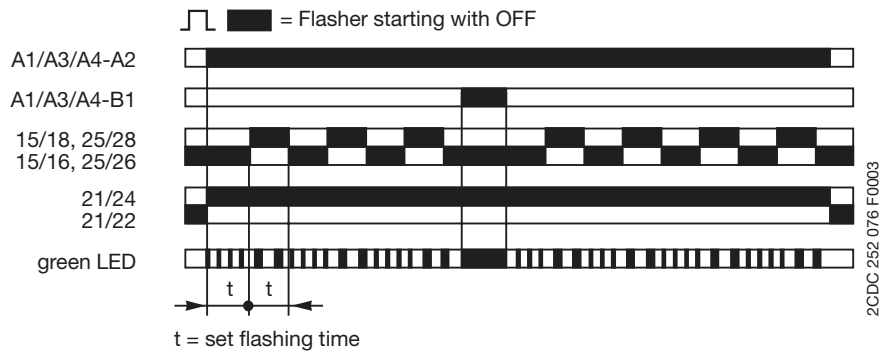
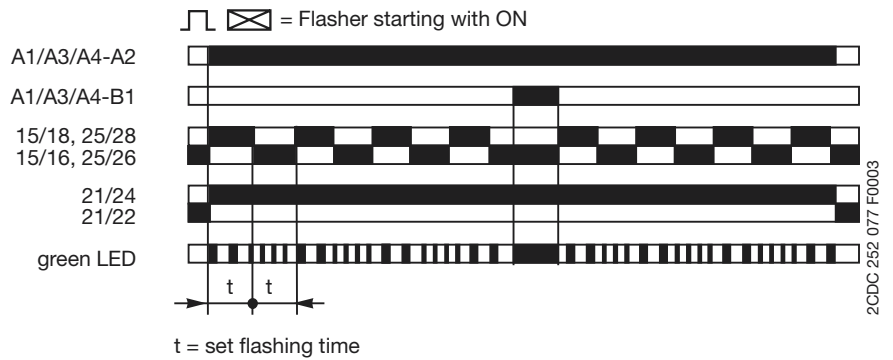

Electronic timer relay CT-MVS

Multifunction timer relay with potential dependent control input

Data sheet

Technical data

Input circuit		
Supply voltage - power consumption	A1-A2	110-240 V AC approx. 2-3 VA
	A3-A2	24 V AC/DC approx. 0,5 VA/W
	A4-A2	42-48 V AC/DC approx. 1.8 VA/W
Tolerance of supply voltage		-15 % ... +10 %
Supply voltage frequency	AC version	50 / 60 Hz
	AC/DC version	DC or 50/60 Hz
Control inputs	A1/A3/A4-B1	external time start
Control voltage of control inputs		supply voltage
Minimum control pulse length		20 ms
Maximum cable length of control inputs		50 m
Duty time		100 %
Timing circuit		
Time ranges 0,05 s - 300 h		1) 0.05-1 s 2) 0.15-3 s 3) 0.5-10 s 4) 1.5-30 s 5) 5-100 s 6) 15-300 s 7) 1.5-30 min 8) 15-300 min 9) 1.5-30 h 10) 15-300 h
Recovery time		< 50 ms
Repeat accuracy (constant parameters)		< 0.2 %
Timing error within the tolerance of supply voltage		< 0.008 % / % Δ U
Timing error within temperature range		< 0.07 % / °C
Display of operational states		
Supply voltage / timer		U/T: green LED steady / flashing while timing
1. output relay energized		R1: red LED
2. output relay energized		R2: red LED
Output circuits		15-16/18, 25(21)-26(22)/28(24)
Number of contacts		Relays, 2 c/o (2nd c/o selectable as instantaneous contact)
Contact material		AgCdo
Rated voltage	acc. to VDE 0110, IEC 60947-1	250 V
Maximum switching voltage		250 V AC, 250 V DC
Rated switching current acc. to IEC 60947-5-1	AC12 (resistive) 230 V	4 A
	AC15 (inductiv) 230 V	3 A
	DC12 (resistive) 24 V	4 A
	DC13 (inductiv) 24 V	2 A
Maximum life	mechanical	30 x 10 ⁶ switching cycles
	electrical (AC12, 230 V, 4 A)	0.1 x 10 ⁶ switching cycles
Short-circuit proof, maximum fuse rating	n/c	10 A fast operating class gL
	n/o	10 A fast operating class gL
General data		
Width of the enclosure		22.5 mm
Wire size		2 x 2.5 mm ² (2 x 14 AWG) stranded with wire end ferrule
Weight		approx. 150 g / 5.25 oz
Mounting position		any
Degree of protection	enclosure / terminals	IP 50 / IP 20
Temperature range	operation	-20 °C ... +60 °C
	storage	-40 °C ... +85 °C
Mounting		DIN rail (EN 50022)

Electronic timer relay CT-MVS

Multifunction timer relay with potential dependent control input

Data sheet

Technical data (continued)

Standards / directives			
Product standard	IEC 61812-1, EN 61812-1		
Electromagnetic compatibility	93/68/EWG		
EMC-test	acc. to EN 61000-6-2		
	acc. to EN 61000-6-4		
ESD	acc. to IEC 61000-4-2, EN 61000-4-2	level 3	6 kV / 8 kV
HF radiation resistance	acc. to IEC 61000-4-3, EN 61000-4-3	level 3	10 V/m
Burst	acc. to IEC 61000-4-4, EN 61000-4-4	level 3	2 kV / 5 kHz
Surge	acc. to IEC 61000-4-5, EN 61000-4-5	level 3	2 kV L-L
HF line emission	acc. to IEC 61000-4-6, EN 61000-4-6	level 3	10 V
Low voltage directive	93/68/EWG		
Operational reliability	acc. to IEC 68-2-6	4 G	
Mechanical shock resistance	acc. to IEC 68-2-6	6 G	
Isolation data			
Rated isolation voltage between supply-, control- and output circuit	acc. to VDE 0110, IEC 60947-1	supply up to 240 V:	300 V
		supply up to 440 V:	500 V
Rated impulse withstand voltage between all isolated circuits	4 kV / 1.2-50 μ s		
	acc. to VDE 0110, IEC 664		
Test voltage between all isolated circuits	2.5 kV, 50 Hz, 1 min		
Pollution category	acc. to VDE 0110, IEC 664 / IEC 255-5	III/C	
Oversoltage category	acc. to VDE 0110, IEC 664 / IEC 255-5	III/C	
Environmental tests	acc. to IEC 68-2-30		
	24 h cycle, 55 °C, 93 % rel. 96 h		

Load limit curves

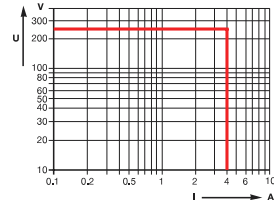

AC load (resistive)

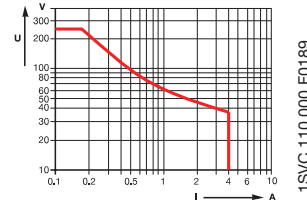

DC load (resistive)

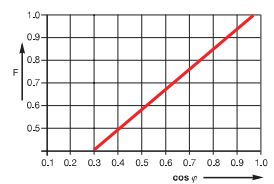

Reduction factor F for inductive AC load

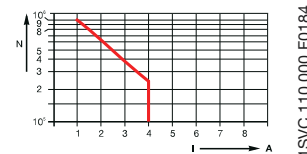

Contact life / number of operations N
220 V 50 Hz 1 AC, 360 operations/h

Dimensions

in mm





ABB STOTZ-KONTAKT GmbH

Eppelheimer Straße 82 69123 Heidelberg, Germany

Postfach 10 16 80 69006 Heidelberg, Germany

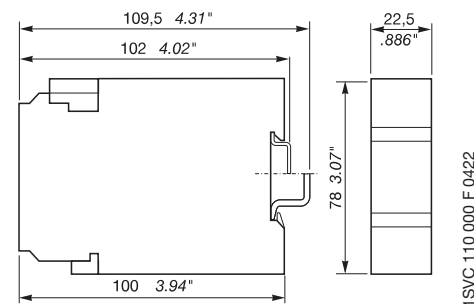
Internet <http://www.abb.de/ssst>

E-Mail desst.info@de.abb.com