

---

## Low Voltage

General Performance

IE2 high efficiency cast iron motors

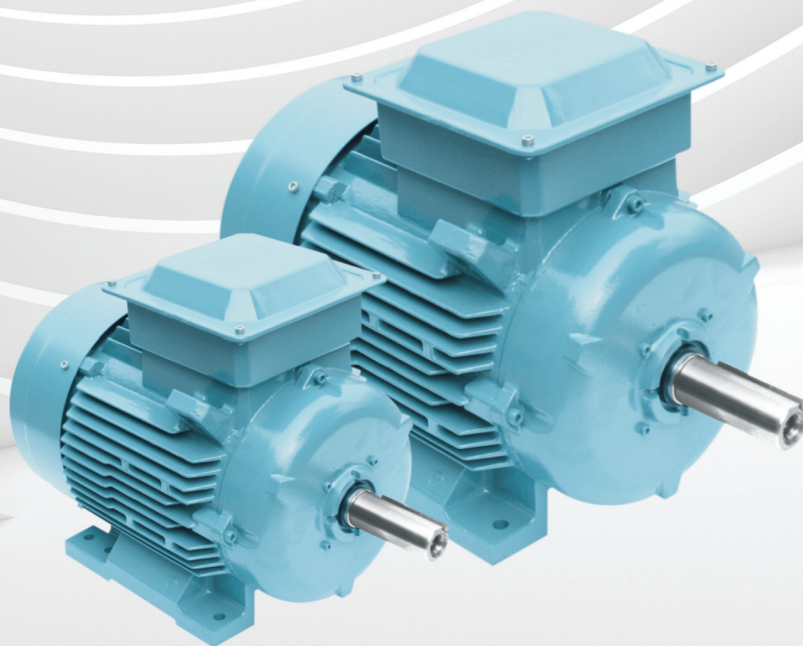

---

**ABB offers a comprehensive range of reliable and high efficiency motors. ABB's general performance IE2 efficiency motors are best suited for applications where simplicity and off-the-shelf availability are paramount.**

---

# General performance IE2 high efficiency cast iron motors Sizes 71 to 355

- 04 - 07**      **Technical data**
- 08**            **Dimension drawings**
- 09 - 11**      **General performance motors  
in brief**

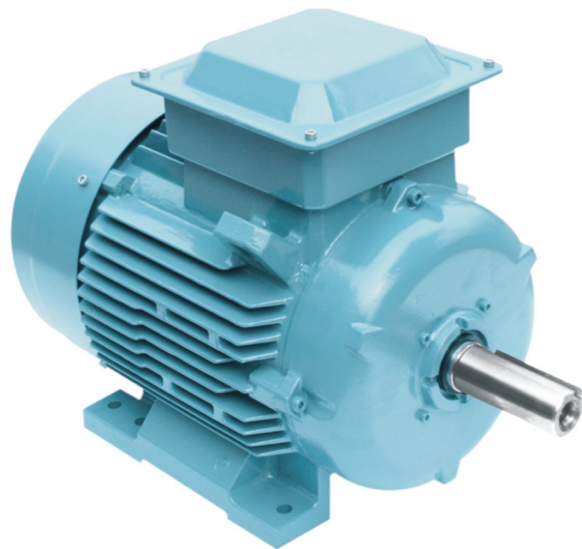

## Technical data

IE2 high efficiency cast iron motors

Technical data for totally enclosed squirrel cage three phase induction motors

IP 55 - IC 411 - Insulation class F, temperature rise class B, IE2 efficiency class according to IEC 60034-30-1:2014, IS 12615:2018

2-Pole, TEFC, 415V, 50Hz, IP55, IC411, Ambt. 50 deg, Rise Class B (70 deg)

Output KW	Frame Size	Speed r/min	Efficiency			Power factor cos $\phi$	Current		Torque			Moment of inertia J=1/4GD <sup>2</sup> kgm <sup>2</sup>	Weight kg
			Full load 100%	3/4 load 75%	1/2 load 50%		I <sub>n</sub> , A	I <sub>s</sub> /I <sub>n</sub>	T <sub>n</sub> Nm	T <sub>s</sub> /T <sub>n</sub>	T <sub>b</sub> /T <sub>n</sub>		
3000 r/min = 2 poles		415V, 50Hz											
0.37	M2BAX71MA2	2760	72.2	72.9	70.3	0.79	0.90	5.0	1.3	2.0	2.4	0.00033	9
0.55	M2BAX71MB2	2785	74.8	75.5	73.0	0.79	1.30	5.0	1.9	2.2	2.7	0.00041	10
0.75	M2BAX80MA2	2820	77.4	78.0	75.7	0.79	1.70	6.0	2.5	2.3	2.8	0.00067	13
1.1	M2BAX80MB2	2840	79.6	80.0	77.9	0.77	2.5	6.0	3.7	2.5	3.0	0.00088	14
1.5	M2BAX90SA2	2875	81.3	82.0	80.3	0.83	3.1	6.0	5.0	2.3	3.0	0.00208	20
2.2	M2BAX90LA2	2878	83.2	84.0	82.6	0.84	4.4	7.0	7.3	2.5	3.1	0.00274	23
3.7	M2BAX100LC2	2890	85.5	85.8	84.3	0.87	6.9	7.0	12.2	3.0	3.8	0.00561	34
5.5	M2BAX132SA2	2915	87.0	87.8	86.7	0.84	10.5	7.0	18.0	2.0	3.4	0.01170	54
7.5	M2BAX132SB2	2910	88.1	89.0	88.7	0.86	13.8	7.0	24.6	2.1	3.5	0.01320	58
9.3	M2BAX160MLJ2	2925	88.8	89.1	87.6	0.87	16.7	7.0	30.3	2.1	3.0	0.038	102
11	M2BAX160MLA2	2925	89.4	89.7	88.2	0.85	20.1	7.0	35.9	2.1	2.9	0.0415	105
15	M2BAX160MLB2	2928	90.3	90.7	90.0	0.87	26.5	7.0	48.9	2.1	3.0	0.0544	120
18.5	M2BAX160MLC2	2928	90.9	91.2	90.4	0.87	32.4	7.0	60.3	2.3	3.0	0.0581	131
22	M2BAX180MLA2	2932	91.3	91.7	91.0	0.88	38.0	7.0	71.6	2.6	3.2	0.0679	152
30	M2BAX200MLA2	2935	92.0	92.4	91.5	0.88	51.5	7.0	97.6	2.2	3.2	0.1077	198
37	M2BAX200MLB2	2950	92.5	92.8	91.7	0.87	64.0	7.0	119.7	3.0	3.8	0.1332	232
45	M2BAX225SMA2	2960	92.9	92.6	92.0	0.88	77.0	7.0	145.1	2.2	3.0	0.2443	295
55	M2BAX250SMA2	2965	93.2	93.8	92.8	0.89	92.0	7.0	177.1	2.5	3.0	0.316	344
75	M2BAX280SA2	2977	93.8	93.8	92.8	0.86	130.0	7.0	241.0	2.2	3.1	0.8	573
90	M2BAX280SMB2	2976	94.1	94.1	93.1	0.89	150.0	7.0	289.0	2.5	2.9	0.9	619
110	M2BAX315SMA2	2982	94.3	94.3	93.3	0.88	185.0	7.0	352.0	2.0	3.0	1.2	819
132	M2BAX315SMB2	2982	94.6	94.6	93.6	0.88	220.0	7.0	423.0	2.2	3.5	1.4	880
160	M2BAX315SMC2	2981	94.8	94.8	93.8	0.89	265.0	7.0	513.0	2.1	3.5	1.7	972
200	M2BAX315MLA2	2981	95.0	95.0	94.0	0.88	332.0	7.0	641.0	2.6	3.2	2.1	1120
250	M2BAX355SMA2	2983	95.0	95.0	94.0	0.86	425.0	7.0	800.0	2.2	3.5	2.7	1381
315	M2BAX355SMB2	2980	95.0	95.0	94.0	0.86	536.0	7.0	1009.0	2.2	3.5	3.4	1524
355	M2BAX355SMC2	2982	95.0	95.0	94.0	0.88	591.0	7.0	1137.0	2.8	3.2	3.6	1598
375	E2BA355MLD2	2982	95.0	95.0	94.0	0.90	610.0	7.0	1201.0	1.6	3.1	6.525	2070

Efficiency values are measured according to IEC 60034-2-1; 2007, IS 15999(Part2 Sec1):2011  
Please note that the values are not comparable without knowing the testing method. ABB has calculated the efficiency values according to indirect method, stray load losses (additional losses) determined from measuring.

I<sub>s</sub> / I<sub>n</sub> = Starting current  
T<sub>s</sub> / T<sub>n</sub> = Locked rotor torque  
T<sub>b</sub> / T<sub>n</sub> = Breakdown

## Technical data

IE2 high efficiency cast iron motors

Technical data for totally enclosed squirrel cage three phase induction motors

IP 55 - IC 411 - Insulation class F, temperature rise class B, IE2 efficiency class according to IEC 60034-30-1:2014, IS 12615:2018

4-Pole, TEFC, 415V, 50Hz, IP55, IC411, Ambt. 50 deg, Rise Class B (70 deg)

Output KW	Frame Size	Speed r/min	Efficiency			Power factor cos $\phi$	Current		Torque			Moment of inertia J=1/4GD <sup>2</sup> kgm <sup>2</sup>	Weight kg
			Full load 100%	3/4 load 75%	1/2 load 50%		I <sub>n</sub> , A	I <sub>s</sub> /I <sub>n</sub>	T <sub>n</sub> Nm	T <sub>s</sub> /T <sub>n</sub>	T <sub>b</sub> /T <sub>n</sub>		
1500 r/min = 4 poles			415V, 50Hz										
0.37	M2BAX71MB4	1395	72.7	72.0	67.0	0.65	1.10	5.0	2.5	1.9	2.2	0.00076	10
0.55	M2BAX80MA4	1415	77.1	76.0	71.0	0.71	1.40	5.0	3.7	2.2	2.8	0.00156	15
0.75	M2BAX80MB4	1425	79.6	78.5	74.3	0.67	1.97	6.0	5.0	3.0	3.5	0.00247	17
1.1	M2BAX90SA4	1430	81.4	80.6	76.8	0.74	2.55	6.0	7.3	3.0	3.5	0.00372	21
1.5	M2BAX90LA4	1430	82.8	82.2	79.4	0.73	3.47	6.0	10.0	3.0	3.5	0.00462	23
2.2	M2BAX100LA4	1435	84.3	84.2	82.1	0.76	4.8	7.0	14.6	2.6	3.3	0.00759	31
3.7	M2BAX112MA4	1435	86.3	86.9	85.9	0.80	7.5	7.0	24.6	2.8	3.3	0.01200	41
5.5	M2BAX132SA4	1450	87.7	88.4	87.6	0.79	11.1	6.0	36.2	1.7	2.8	0.02570	57
7.5	M2BAX132MA4	1455	88.7	89.2	88.3	0.77	15.3	6.0	49.2	1.7	3.0	0.03200	68
9.3	M2BAX160MLJ4	1455	89.3	89.8	88.0	0.81	17.9	7.0	61.0	2.0	2.9	0.0738	107
11	M2BAX160MLA4	1455	89.8	90.4	89.4	0.81	21.0	7.0	72.2	2.1	2.9	0.084	115
15	M2BAX160MLB4	1460	90.6	91.2	90.2	0.81	28.4	7.0	98.0	2.5	3.0	0.1025	134
18.5	M2BAX180MLA4	1457	91.2	91.8	90.9	0.81	35.0	7.0	121.2	2.7	3.5	0.1217	155
22	M2BAX180MLB4	1460	91.6	92.1	91.2	0.80	42.0	7.0	143.8	2.4	3.2	0.1396	171
30	M2BAX200MLA4	1474	92.3	92.5	91.8	0.81	55.5	7.0	194.3	2.5	3.1	0.2572	229
37	M2BAX225SMA4	1475	92.7	93.1	92.2	0.84	66.5	6.5	239.4	2.1	2.7	0.3605	267
45	M2BAX225SMB4	1478	93.1	93.5	92.6	0.83	81.5	7.0	290.6	2.2	2.9	0.4314	304
55	M2BAX250SMA4	1478	93.5	93.7	92.9	0.85	96.8	7.0	355.2	2.7	3.0	0.5331	342
75	M2BAX280SA4	1483	94.0	94.0	93.0	0.83	134.0	7.0	481.0	2.7	3.0	1.25	554
90	M2BAX280SMB4	1483	94.2	94.2	93.2	0.84	158.0	7.0	580.0	2.6	3.0	1.5	616
110	M2BAX315SMA4	1487	94.5	94.5	93.5	0.85	190.0	7.0	706.0	2.2	2.9	2.3	849
132	M2BAX315SMB4	1487	94.7	94.7	93.7	0.85	228.0	7.0	848.0	2.3	3.1	2.6	905
160	M2BAX315SMC4	1487	94.9	94.9	93.9	0.84	278.0	7.0	1027.0	2.4	3.0	2.9	958
200	M2BAX315MLA4	1487	95.1	95.1	94.1	0.85	345.0	7.0	1284.0	2.4	3.0	3.5	1108
250	M2BAX355SMA4	1487	95.1	95.1	94.1	0.85	430.0	7.0	1605.0	1.9	3.1	5.4	1473
315	M2BAX355SMB4	1486	95.1	95.1	94.1	0.85	544.0	7.0	2024.0	2.4	3.0	6.9	1730
355	M2BAX355SMC4	1487	95.1	95.1	94.1	0.86	605.0	7.0	2280.0	2.4	3.0	7.2	1730
400	E2BA355MLB4H	1486	95.1	95.1	94.1	0.86	680.0	7.0	2570.0	2.3	2.8	11.065	2430

Efficiency values are measured according to IEC 60034-2-1; 2007, IS 15999(Part2 Sec1):2011  
 Please note that the values are not comparable without knowing the testing method. ABB has calculated the efficiency values according to indirect method, stray load losses (additional losses) determined from measuring.

I<sub>s</sub> / I<sub>n</sub> = Starting current  
 T<sub>s</sub> / T<sub>n</sub> = Locked rotor torque  
 T<sub>b</sub> / T<sub>n</sub> = Breakdown

## Technical data

IE2 high efficiency cast iron motors

Technical data for totally enclosed squirrel cage three phase induction motors

IP 55 - IC 411 - Insulation class F, temperature rise class B, IE2 efficiency class according to IEC 60034-30-1:2014, IS 12615:2018

6-Pole, TEFC, 415V, 50Hz, IP55, IC411, Ambt. 50 deg, Rise Class B (70 deg)

Output KW	Frame Size	Speed r/min	Efficiency			Power factor cos $\phi$	Current		Torque			Moment of inertia J=1/4GD <sup>2</sup> kgm <sup>2</sup>	Weight kg
			Full load 100%	3/4 load 75%	1/2 load 50%		I <sub>n</sub> , A	I <sub>s</sub> /I <sub>n</sub>	T <sub>n</sub> Nm	T <sub>s</sub> /T <sub>n</sub>	T <sub>b</sub> /T <sub>n</sub>		
1000 r/min = 6 poles		415V, 50Hz											
0.37	M2BAX80MA6	910	69.0	68.1	63.1	0.62	1.20	4.0	3.9	2.0	2.4	0.00173	13
0.55	M2BAX80MB6	910	73.1	72.8	69.2	0.66	1.60	4.0	5.8	2.1	2.5	0.00274	15
0.75	M2BAX90SA6	945	75.9	74.3	69.2	0.62	2.2	4.5	7.6	2.4	3.2	0.00438	21
1.1	M2BAX90LA6	935	78.1	77.3	73.3	0.63	3.1	4.5	11.2	2.3	2.9	0.00507	24
1.5	M2BAX100LA6	945	79.8	79.7	77.0	0.67	3.9	4.5	15.2	1.8	2.3	0.00795	31
2.2	M2BAX112MA6	950	81.8	81.7	79.0	0.68	5.5	5.0	22.1	1.8	2.6	0.01160	40
3.7	M2BAX132SB6	960	84.3	84.7	83.4	0.71	8.6	5.0	36.8	1.5	2.3	0.02830	60
5.5	M2BAX132MB6	965	86.0	86.0	84.2	0.70	12.7	5.0	54.4	1.5	2.8	0.03970	77
7.5	M2BAX160MLA6	957	87.2	88.0	86.8	0.77	15.6	6.5	74.8	1.7	2.6	0.089	122
9.3	M2BAX160MLJ6	965	88.0	88.6	87.8	0.77	19.1	6.5	92.0	2.0	2.8	0.119	141
11	M2BAX160MLB6	965	88.7	89.2	88.5	0.75	23.0	7.0	108.8	2.1	2.8	0.1293	147
15	M2BAX180MLA6	970	89.7	90.1	89.4	0.76	30.5	7.0	147.6	2.0	3.0	0.1522	173
18.5	M2BAX200MLA6	965	90.4	90.8	90.0	0.77	37.0	6.0	183.0	1.5	2.5	0.198	190
22	M2BAX200MLB6	970	90.9	91.2	90.6	0.77	43.7	6.0	216.5	1.5	2.5	0.2384	212
30	M2BAX225SMA6	981	91.7	92.0	91.2	0.82	55.8	6.5	291.9	2.1	2.8	0.5687	284
37	M2BAX250SMA6	981	92.2	92.4	91.9	0.81	68.9	6.0	360.0	2.0	2.6	0.8042	337
45	M2BAX280SA6	990	92.7	92.7	90.7	0.78	87.0	7.0	434.0	2.4	2.7	1.85	535
55	M2BAX280SB6	990	93.1	93.1	91.1	0.81	102.0	7.0	531.0	2.5	2.7	2.2	582
75	M2BAX315SMA6	993	93.7	93.7	91.7	0.78	143.0	7.0	721.0	2.5	3.0	3.2	789
90	M2BAX315SMB6	993	94.0	94.0	92.0	0.81	165.0	7.0	865.0	2.7	3.0	4.1	879
110	M2BAX315SMC6	992	94.3	94.3	92.3	0.80	203.0	7.0	1059.0	2.6	3.0	4.9	957
132	M2BAX315MLA6	990	94.6	94.6	92.6	0.81	241.0	7.0	1273.0	2.7	3.0	5.8	1091
160	M2BAX355SMA6	993	94.8	94.8	92.8	0.80	292.0	7.0	1539.0	2.3	2.6	7.3	1370
200	M2BAX355SMB6	992	95.0	95.0	93.0	0.81	360.0	7.0	1925.0	2.2	2.6	9.7	1518
250	M2BAX355SMC6	991	95.0	95.0	93.0	0.83	442.0	7.0	2409.0	2.8	3.0	11.3	1675
275	E2BA355MLB6K	990	95.0	95.0	93.0	0.82	491.0	7.0	2653.0	2.5	2.8	15.06	2040
315	E2BA355MLB6	990	95.0	95.0	93.0	0.84	549.0	7.0	3039.0	2.3	2.8	15.06	2250
355	E2BA355MLB6H**	990	95.0	95.0	93.0	0.84	619.0	7.0	3424.0	1.3	2.7	15.975	2250

\*\* Temp. Rise Class F

Efficiency values are measured according to IEC 60034-2-1; 2007, IS 15999(Part2 Sec1):2011  
Please note that the values are not comparable without knowing the testing method. ABB has calculated the efficiency values according to indirect method, stray load losses (additional losses) determined from measuring.

I<sub>s</sub> / I<sub>n</sub> = Starting current  
T<sub>s</sub> / T<sub>n</sub> = Locked rotor torque  
T<sub>b</sub> / T<sub>n</sub> = Breakdown

## Technical data

IE2 high efficiency cast iron motors

Technical data for totally enclosed squirrel cage three phase induction motors

IP 55 - IC 411 - Insulation class F, temperature rise class B, IE2 efficiency class according to IEC 60034-30-1:2014, IS 12615:2018  
 8-Pole, TEFC, 415V, 50Hz, IP55, IC411, Ambt. 50 deg, Rise Class B (70 deg)

Output KW	Frame Size	Speed r/min	Efficiency			Power factor cos $\phi$	Current		Torque			Moment of inertia J=1/4GD <sup>2</sup> kgm <sup>2</sup>	Weight kg
			Full load 100%	3/4 load 75%	1/2 load 50%		I <sub>n</sub> , A	I <sub>s</sub> /I <sub>n</sub>	T <sub>n</sub> Nm	T <sub>s</sub> /T <sub>n</sub>	T <sub>b</sub> /T <sub>n</sub>		
750 r/min = 8 poles		415V, 50Hz											
0.12	M2BAX71MB8	680	39.8	34	24.9	0.60	0.70	3.0	1.7	2.6	2.7	0.0011	11
0.18	M2BAX80MA8	700	45.9	40.7	29.8	0.61	0.90	3.0	2.5	2.5	2.8	0.0019	15
0.25	M2BAX80MB8	690	50.6	46.8	38.2	0.62	1.10	3.0	3.5	2.3	2.4	0.0024	16
0.37	M2BAX90SA8	690	56.1	53	43.9	0.61	1.5	3.0	5.1	2.0	2.4	0.0044	22
0.55	M2BAX90LA8	680	61.7	61.1	55.8	0.62	2.0	3.0	7.7	1.7	1.9	0.0049	24
0.75	M2BAX100LA8	710	66.2	62.1	54.1	0.61	2.6	4.0	10.1	2.0	2.5	0.0072	30
1.1	M2BAX100LB8	695	70.8	70.6	66.2	0.64	3.4	4.0	15.1	2.0	2.2	0.0087	32
1.5	M2BAX112MA8	680	74.1	74.1	72.8	0.70	4.0	4.0	21.1	1.7	2	0.0118	40
2.2	M2BAX132SA8	710	77.6	76.2	72	0.65	6.1	4.5	29.6	1.5	2.3	0.0334	69
3.7	M2BAX160MLA8	715	81.4	81.4	80.4	0.64	9.8	5.0	49.4	1.5	2.3	0.0590	100
5.5	M2BAX160MLB8	720	83.8	83.8	82.8	0.66	13.8	5.0	73.0	1.5	2.3	0.0940	127
7.5	M2BAX160MLC8	720	85.3	85.3	83.3	0.64	19.0	5.0	99.5	1.5	2.3	0.1170	143
9.3	M2BAX180MLA8	720	86.3	86.3	83.6	0.61	24.6	5.0	123.4	1.7	2.6	0.1470	166
11	M2BAX180MLB8	720	86.9	86.9	84.5	0.68	26.0	5.0	145.9	1.5	2.2	0.2020	200
15	M2BAX200MLA8	725	88	88	85.8	0.68	35.0	5.0	197.6	1.4	2.1	0.2720	235
18.5	M2BAX225SMA8	735	88.6	88.6	87.6	0.73	40.0	5.0	240.4	2.1	2.3	0.4950	254
22	M2BAX225SMB8	735	89.1	89.1	88.1	0.75	45.7	5.0	285.9	1.9	2.2	0.5870	286
30	M2BAX250SMA8	735	89.8	89.8	88.8	0.74	62.8	5.0	389.8	1.9	2.2	0.8620	348
37	M2BAX280SA8	740	90.3	90.3	88.3	0.73	78.0	7.0	477.0	1.8	3	1.8500	558
45	M2BAX280SB8	742	90.7	90.7	88.7	0.77	90.0	7.0	579.0	1.8	3	2.2000	598
55	M2BAX315SMA8	743	91	91	89	0.75	112.0	7.0	707.0	1.7	2.8	3.2000	792
75	M2BAX315SMB8	742	91.6	91.6	89.6	0.78	146.0	7.0	965.0	1.7	2.8	4.1000	880
90	M2BAX315SMC8	742	91.9	91.9	89.9	0.78	175.0	7.0	1158.0	1.8	2.8	4.9000	959
110	M2BAX315MLA8	743	92.3	92.3	90.3	0.80	207.0	7.0	1414.0	1.8	2.8	5.8000	1091
132	M2BAX355SMA8	745	92.6	92.6	90.6	0.76	260.0	7.0	1692.0	1.6	2.8	7.9000	1413
160	M2BAX355SMB8	744	93	93	91	0.76	315.0	7.0	2054.0	1.76	2.85	9.7000	1574
200	M2BAX355SMC8	745	93.5	93.5	91	0.78	382.0	7.0	2563.0	1.76	2.84	11.3000	1600
225	E2BA355MLB8H	740	93.5	93.5	91.5	0.77	434.8	7.0	2904.0	1.7	2.6	16.0500	2100
250	E2BA355MLB8k**	740	93.5	93.5	91.5	0.81	460.0	7.0	3226.0	1.6	2.6	16.5000	2225

\*\* Temp. Rise Class F

Efficiency values are measured according to IEC 60034-2-1; 2007,IS 15999(Part2 Sec1):2011  
 Please note that the values are not comparable without knowing the testing method. ABB has calculated the efficiency values according to indirect method, stray load losses (additional losses) determined from measuring.

I<sub>s</sub> / I<sub>n</sub> = Starting current  
 T<sub>s</sub> / T<sub>n</sub> = Locked rotor torque  
 T<sub>b</sub> / T<sub>n</sub> = Breakdown

## Dimension drawings

General performance IE2 high efficiency cast iron motors Sizes 71 - 355

Foot-mounted motor IM1001, B3

Flange-mounted motor IM 3001, B5

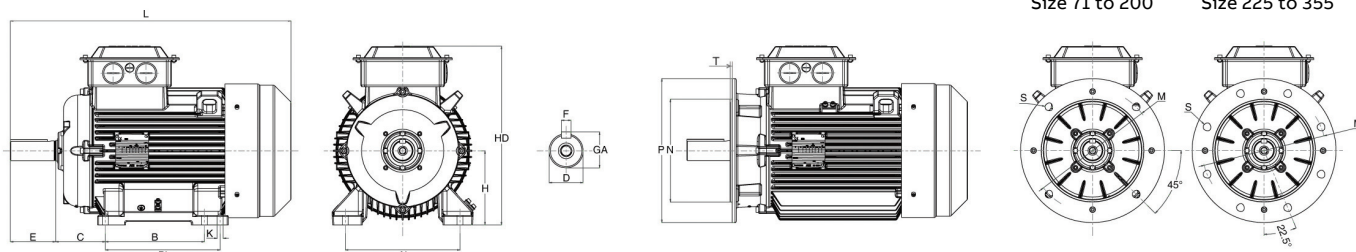

Motor Size	D Poles		GA Poles		F Poles		E Poles		L max Poles		A	B	B'	C	HD	K	H	M	N	P	S	T
	2	4-8	2	4-8	2	4-8	2	4-8	2	4-8												
<b>General performance cast iron motors</b>																						
71M	14	14	16.0	16.0	5	5	30	30	257	257	112	90	-	45	175	7	71	130	110	160	10	3.5
80M	19	19	21.5	21.5	6	6	40	40	309	309	125	100	-	50	192	10	80	165	130	200	12	3.5
90SL	24	24	27.0	27.0	8	8	50	50	351	351 <sup>5)</sup>	140	100	125	56	217	10	90	165	130	200	12	3.5
100L	28	28	31.0	31.0	8	8	60	60	376	376	160	140	-	63	240	12	100	215	180	250	15	4.0
112M	28	28	31.0	31.0	8	8	60	60	411	411	190	140	-	70	252	12	112	215	180	250	15	4.0
132SM	38	38	41.0	41.0	10	10	80	80	521	521 <sup>6)</sup>	216	140	178	89	301	12	132	265	230	300	15	4.0
160	42	42	45.0	45.0	12	12	110	110	586	586 <sup>1),1)</sup>	254	210	254	108	414	14.5	160	300	250	350	19	5.0
180 <sup>7)</sup>	48	48	51.5	51.5	14	14	110	110	684	684 <sup>2)</sup>	279	241	279	121	434	14.5	180	300	250	350	19	5.0
200 <sup>8)</sup>	55	55	59.0	59.0	16	16	110	110	728	728 <sup>3)</sup>	318	267	305	133	474	18.5	200	350	300	400	19	5.0
225	55	60	59.0	64.0	16	18	110	140	854	854 <sup>4)</sup>	356	286	311	149	540	18.5	225	400	350	450	19	5.0
250	60	65	64.0	69.0	18	18	140	140	882	882	406	311	349	168	585	24	250	500	450	550	19	5.0
280S	65	75	69.0	79.5	18	20	140	140	982	982	457	368	-	190	775	24	280	500	450	550	19	5.0
280SM	65	75	69.0	79.5	18	20	140	140	1052	1052	457	368	419	190	775	24	280	500	450	550	19	5.0

Motor	D		GA		F		E		L Max		A	B	B'	C	HD	K	H	M	N	P	S	T
	2	4_8	2	4_8	2	4_8	2	4_8	2	4_8												
M2BAX 315SM	65	80	69.0	85.0	18	22	140	170	1216	1246	508	406	457	216	872	28	315	600	550	660	24	6.0
M2BAX 315ML	65	90	69.0	95.0	18	25	140	170	1326	1356	508	457	508	216	872	28	315	600	550	660	24	6.0
M2BAX 355SM	70	100	74.5	106.0	20	28	140	210	1399	1469	610	500	560	254	960	35	355	740	680	800	24	6.0
E2BA 355MLB8K	-	100	-	106.0	-	28	-	210	-	1680	610	560	630	254	965	28	355	740	680	800	24	6.0
E2BA 355MLB4H	-	100	-	106.0	-	28	-	210	-	1680	610	560	630	254	995	28	355	740	680	800	24	6.0
E2BA 355MLD2	75	-	79.5	-	20	-	140	-	1610	-	610	560	630	254	995	28	355	740	680	800	24	6.0
E2BA 355MLB6H	-	100	-	106.0	-	28	-	210	-	1680	610	560	630	254	995	28	355	740	680	800	24	6.0
E2BA355MLB6K	-	100	-	106.0	-	28	-	210	-	1574	610	560	630	254	965	28	355	740	680	800	24	6.0
E2BA 355MLB6	-	100	-	106.0	-	28	-	210	-	1680	610	560	630	254	995	28	355	740	680	800	24	6.0
E2BA355MLB8H	-	100	-	106.0	-	28	-	210	-	1574	610	560	630	254	965	28	355	740	680	800	24	6.0

Above table gives the main dimensions in mm.

- 1) M2BAX160MLC2, B4, J6 L = 626
- 1') M2BAX160MLB6 L = 646
- 2) M2BAX180MLB4, A6 L = 704
- 3) M2BAX200MLB2, A4, B6 L = 768
- 4) M2BAX225SMB4, A6 L = 884
- 5) M2BAX90SA2,SA4,SA6 L = 335
- 6) M2BAX132SA2,B2,SA4,SB6 L = 479
- 7) M2BAX180MLB8 refer GAD
- 8) M2BAX200MLA8 refer GAD

## Motors in brief

General performance IE2 high efficiency cast iron motors in brief

Size	71	80	90	100	112	132	
<b>Stator</b>	Material	Cast Iron Grade 150:ISO 185					
	Paint colour shade	Munsell blue 8B 4.5/3.25 / NCS 4822 B05G					
	Surface Treatment	C3 medium according to ISO / EN 12944-5					
<b>Feet</b>	Integrated with stator						
	Material	Cast iron grade 150 : ISO 185					
<b>Bearing end shields</b>	Material	Cast iron grade 150 : ISO 185					
	Paint colour shade	Munsell blue 8B 4.5/3.25/NCS 4822 B05G					
	Surface Treatment	C3 medium according to ISO / EN 12944-5					
<b>Bearings</b>	D-end	6203-2Z/C3	6204-2Z/C3	6205-2Z/C3	6206-2Z/C3	6206-2Z/C3	6208-2Z/C3
	N-end	6202-2Z/C3	6203-2Z/C3	6204-2Z/C3	6205-2Z/C3	6205-2Z/C3	6208-2Z/C3
<b>Axially-locked</b>	Retaining Ring	As standard, locked at D-end					
<b>Bearing seals</b>	Axial seal as standard, radial on request						
<b>Lubrication</b>	Permanently lubricated shielded bearings						
<b>Rating plate</b>	Material	Aluminium					
<b>Terminal Box</b>	Frame material	Cast Iron, Integral to stator frame					
	Cover material	Sheet of steel, Cold rolled					
	Cover screws material	Steel 8.8					
<b>Connections</b>	Cable entries	2xM16	2xM25	2xM32			
	Cable Sizes	2Rx3Cx4mm <sup>2</sup>	2Rx3Cx6mm <sup>2</sup>	2Rx3Cx10mm <sup>2</sup>			
	Terminal Stud Size	M4	M4	M5			
	Terminals	Upto 2HP - STAR / 3 Leads > 2 HP - DELTA / 6 Leads, (Cable lugs not included)					
<b>Fan</b>	Material	Polypropylene, Reinforced with 20% glass fibre					
<b>Fan Cover</b>	Material	Sheet of steel, cold rolled					
	Paint Colour shade	Munsell blue 8B 4.5/3.25/NCS 4822 B05G					
	Surface Treatment	C3 medium according to ISO/EN 12944-5					
<b>Stator winding</b>	Material	Copper					
	Insulation	Insulation class F, Temperature rise class B unless otherwise stated					
	Winding protection	-					
<b>Rotor winding</b>	Material	Pressure diecast aluminum					
<b>Balancing method</b>	Half Key Balancing as Standard						
<b>Key ways</b>	Open Key Way						
<b>Enclosure</b>	IP 55, Higher protection on request						
<b>Cooling method</b>	IC 411						
<b>Drain holes</b>	Drain holes with closable plastic plugs, open on delivery						
<b>Lifting lugs</b>	Integrated with the stator						

## Motors in brief

General performance IE2 high efficiency cast iron motors

Size	160	180	200	225	250	
<b>Stator</b>	Material	Cast iron grade 200 : ISO 185				
	Paint colour shade	Munsell blue 8B 4.5/3.25 / NCS 4822 B05G				
	Surface Treatment	C3 medium according to ISO / EN 12944-5				
<b>Feet</b>		Integrated with stator				
	Material	Cast iron grade 200 : ISO 185				
<b>Bearing end shields</b>	Material	Cast iron grade 200 : ISO 185				
	Paint colour shade	Munsell blue 8B 4.5/3.25 / NCS 4822 B05G				
	Surface Treatment	Aliphatic polyurethane enamel paint_70µm				
<b>Bearings</b>	D-end	6209-2Z/C3	6310-2Z/C3	6312-2Z/C3	6313-2Z/C3	6315-2Z/C3
	N-end	6209-2Z/C3	6209-2Z/C3	6209-2Z/C3	6210-2Z/C3	6212-2Z/C3
<b>Axially-locked</b>	Inner Bearing Cover	As standard, locked at D-end				
<b>Bearing seals</b>	D-end	V-ring				
	N-end	V-ring				
<b>Lubrication</b>		Permanently lubricated shielded bearings				
<b>Terminal Box</b>	Material	Sheet of Steel, Cold Rolled				
	Surface	Treatment Similar to stator				
	Screws	Steel 8.8				
<b>Connections</b>	Cable Entries	2xM40, 1xM16			2xM50, 1xM16	
	Cable Sizes	2Rx3Cx70mm <sup>2</sup>			2Rx3Cx120mm <sup>2</sup>	
	Terminal Stud Size	M6			M10	
	Terminal Box	6 terminals for connection, Cable lugs not included				
<b>Fan</b>	Material	Polypropylene, Reinforced with 20% glass fibre				
<b>Fan Cover</b>	Material	Sheet of Steel, Cold Rolled				
	Paint colour shade	Munsell blue 8B 4.5/3.25 / NCS 4822 B05G				
	Surface Treatment	Similar to stator				
<b>Stator winding</b>	Material	Copper				
	Insulation	Insulation class F				
<b>Rotor winding</b>	Material	Diecast aluminum				
<b>Balancing method</b>		Half Key Balancing as standard				
<b>Key ways</b>		Open Key Way				
<b>Enclosure</b>		IP 55				
<b>Cooling method</b>		IC 411				
<b>Drain holes</b>		Drain holes with closable plastic plugs, open on delivery				
<b>Lifting lugs</b>		Integrated with the stator				

## Motors in brief

General performance IE2 high efficiency cast iron motors

Size		280 2-8 Pole	315 2 Pole	315 4-8 Pole	355 2 Pole	355 4-8 Pole
<b>Stator</b>	Material	Cast iron grade 150, IS:210 <sup>1)</sup>				
	Paint colour shade	Munsell blue 8B 4.5/3.25 / NCS 4822 B05G				
	Surface Treatment	C3 medium according to ISO / EN 12944-5				
<b>Feet</b>		Integrated with stator				
	Material	Cast iron grade 150, IS:210 <sup>1)</sup>				
<b>Bearing end shields</b>	Material	Cast iron grade 150, IS:210 <sup>1)</sup>				
	Paint colour shade	Munsell blue 8B 4.5/3.25 / NCS 4822 B05G				
	Surface Treatment	Aliphatic polyurethane paint ≥80µm				
<b>Bearings</b>	D-end	6316/C3	6316/C3	6319/C3	6319/C3 <sup>2)</sup>	6322/C3
	N-end	6316/C3	6316/C3	6316/C3	6319/C3 <sup>2)</sup>	6319/C3 <sup>2)</sup>
<b>Axially-locked</b>	Inner Bearing Cover	As standard, locked at D-end				
<b>Bearing seals</b>	D-end	Oil Seal ***				
	N-end	- ***				
<b>Lubrication</b>		Regreasable Bearings, Regreasing nipple M10X1				
<b>Terminal Box</b>	Material	Cast iron grade 150, IS:210 <sup>1)</sup>				
	Surface	Similar to stator				
	Screws	Steel				
<b>Connections</b>	Cable Entries	2 x 2" BSC <sup>3)</sup>		2 x 2-1/2" BSC* <sup>3)</sup>		
	Cable Sizes	280 : 2Rx3Cx185Sqmm Cu/Al Cable 315 : 2Rx3Cx240Sqmm Cu/Al Cable 355 : 2Rx3Cx240Sqmm Cu/Al Cable*				
	Terminal Stud Size	M12		M16 <sup>4)</sup>		
	Terminal Box	6 terminals for connection, (Cable lugs not included)				
	Fan	Material	Polypropylene, Reinforced with 20% glass fibre			Aluminium <sup>5)</sup>
<b>Fan Cover</b>	Material	Sheet of steel, Cold Rolled				
	Paint colour shade	Munsell blue 8B 4.5/3.25 / NCS 4822 B05G				
	Surface Treatment	Similar to stator				
<b>Stator winding</b>	Material	Copper				
	Insulation	Insulation class F				
<b>Rotor winding</b>	Material	Diecast aluminum				
<b>Balancing method</b>		Half Key Balancing as standarad				
<b>Key ways</b>		Open Key Way				
<b>Enclosure</b>		IP 55				
<b>Cooling method</b>		IC 411				
<b>Drain holes</b>		Drain holes with closable plastic plugs, open on delivery				
<b>Lifting lugs</b>		Bolted to the Stator				

\*Cable Size for 355MLD2, 355MLB6H & 355MLB4H will be 2Rx3Cx300 Sqmm Cu/Al , Threaded opening 2x3" BSC

For M2BAX series, following is applicable:

- 1) Cast Iron Grade 200, IS:210
- 2) Bearing Size: 6316/C3
- 3) Cable Entries for
  - 280 to 315 frame - 2xM63, 2xM20
  - 355 frame - 2xM75, 2xM20
- 4) Terminal Stud Size: M12
- 5) For all Frames,fan material is Polypropylene,Reinforced with 20% glass fibre.

\*\*\*Bearings Seals in M2BAX 280 to 355 frame is V-ring at DE and NDE side.

—  
**ABB India Limited**  
32, Industrial Area,  
N.I.T., Faridabad - 121 001  
Tel: +91 129 2448100

**[www.abb.co.in](http://www.abb.co.in)**

We reserve the right to make technical changes or modify the contents of this document without prior notice. With regard to purchase orders, the agreed particulars shall prevail. ABB does not accept any responsibility whatsoever for potential errors or possible lack of information in this document.  
We reserve all rights in this document and in the subject matter and illustrations contained therein. Any reproduction, disclosure to third parties or utilization of its content - in whole or in parts - is forbidden without ABB's prior written consent.



---

## **Low Voltage**

General Performance  
IE3 Premium efficiency  
cast iron motors

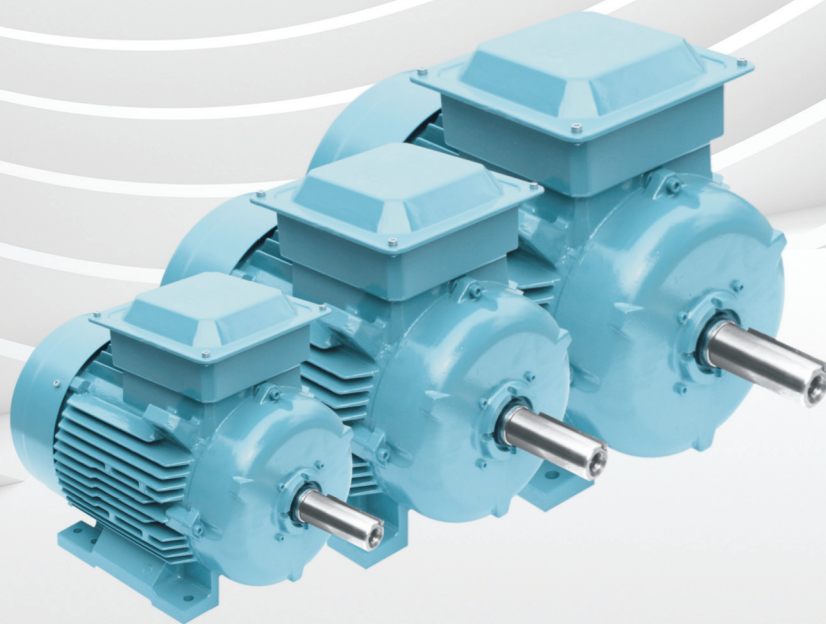

---

**ABB offers a comprehensive range of reliable and high efficiency motors. ABB's general performance IE3 efficiency motors are best suited for industries where quality, robustness and reliability are paramount.**

---

# General performance IE3 premium efficiency cast iron motors Sizes 71 to 355

- 04 - 07**      **Technical data**
- 08**            **Dimension drawings**
- 09 - 11**      **General performance motors  
in brief**

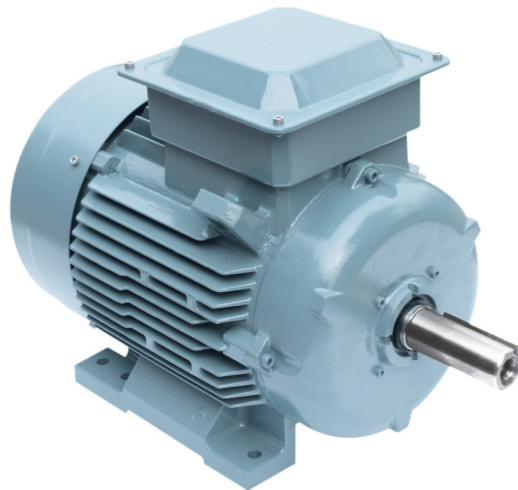

## Technical data

IE3 premium efficiency cast iron motors

Technical data for totally enclosed squirrel cage three phase induction motors

IP 55 - IC 411 - Insulation class F, temperature rise class B, IE3 efficiency class according to IEC 60034-30-1:2014, IS 12615:2018

2-Pole, TEFC, 415V, 50Hz, IP55, IC411, Ambt. 50 deg, Rise Class B (70 deg)

Output KW	Frame Size	Speed r/min	Efficiency			Power factor cos $\phi$	Current		Torque			Moment of inertia J=1/4GD <sup>2</sup> kgm <sup>2</sup>	Weight kg
			Full load 100%	3/4 load 75%	1/2 load 50%		I <sub>n</sub> , A	I <sub>s</sub> /I <sub>n</sub>	T <sub>n</sub> Nm	T <sub>s</sub> /T <sub>n</sub>	T <sub>b</sub> /T <sub>n</sub>		
3000 r/min = 2 poles			415V, 50Hz										
0.37	M2BAX71MC2	2790	75.5	75.4	72.7	0.72	0.95	5.5	1.3	2.1	2.5	0.00033	9
0.55	M2BAX71MB2	2782	78.1	78.4	76.4	0.73	1.35	5.5	1.9	2.1	2.6	0.00041	10
0.75	M2BAX80MC2	2870	80.7	80.0	76.7	0.76	1.7	6.5	2.5	2.8	3.6	0.00080	14
1.1	M2BAX80MD2	2865	82.7	83.3	81.9	0.80	2.3	7.0	3.7	2.8	3.6	0.00119	17
1.5	M2BAX90SB2	2882	84.2	84.6	83.0	0.83	3	6.0	5.0	2.7	3.3	0.00224	21
2.2	M2BAX90SLA2	2890	85.9	86.7	85.8	0.88	4.4	7.0	7.3	3.0	3.5	0.00304	25
3.7	M2BAX100LKB2	2900	87.8	88.1	86.8	0.85	6.9	7.7	12.2	3.5	3.9	0.00756	42
5.5	M2BAX132SMA2	2900	89.2	89.6	88.9	0.82	10.5	7.0	18.1	2.1	3.3	0.01625	69
7.5	M2BAX132SMB2	2905	90.1	90.5	89.7	0.82	14.2	6.5	24.7	2.2	3.5	0.01821	74
9.3	M2BAX160MLJ2	2935	90.7	90.8	89.7	0.86	16.6	7.7	30.3	2.5	3.5	0.053	115
11	M2BAX160MLA2	2935	91.2	91.5	90.8	0.87	19.2	7.7	35.8	2.4	3.2	0.057	118
15	M2BAX160MLB2	2940	91.9	92.1	91.3	0.86	26.5	7.7	48.7	2.9	4.0	0.063	126
18.5	M2BAX160MLC2	2950	92.4	92.9	92.5	0.90	33.0	7.7	59.9	3.0	3.9	0.076	144
22	M2BAX180MLA2	2950	92.7	93.2	92.7	0.88	37.7	7.7	71.2	2.6	3.3	0.110	181
30	M2BAX200MLA2	2950	93.3	93.6	93.2	0.89	51	7.7	97.1	2.4	2.9	0.182	230
37	M2BAX200MLB2	2955	93.7	94.1	93.6	0.88	62.7	7.7	119.6	2.8	3.4	0.222	257
45	M2BAX225SMA2	2965	94.0	94.1	93.3	0.86	77.7	7.7	144.9	2.8	3.4	0.296	287
55	M2BAX250SMA2	2965	94.3	94.3	93.5	0.87	93.5	7.0	177.2	2.7	3.1	0.426	344
75	M2BAX280SMB2	2978	94.7	94.7	93.7	0.85	129.0	7.7	240.0	2.1	2.8	0.900	627
90	M2BAX280SMC2	2975	95.0	95.0	94.0	0.88	150.0	7.7	289.0	2.0	2.8	0.990	649
110	M2BAX315SMB2	2982	95.2	95.2	94.2	0.87	185.0	7.7	352.0	1.9	2.8	1.300	845
132	M2BAX315SMC2	2982	95.4	95.4	94.4	0.87	220.0	7.7	423.0	2.0	2.8	1.500	901
160	M2BAX315SMD2	2983	95.6	95.6	94.6	0.88	265.0	7.7	512.0	2.2	2.8	1.700	968
200	M2BAX315MLA2	2984	95.8	95.8	94.8	0.86	338.0	7.7	640.0	2.6	3.0	2.100	1109
250	M2BAX355SMA2	2985	95.8	95.8	94.8	0.87	417.0	7.7	800.0	2.1	3.3	3.000	1492
315	M2BAX355SMB2	2980	95.8	95.8	94.8	0.87	525.0	7.7	1009.0	2.1	3.0	3.400	1576
355	M2BAX355SMC2	2984	95.8	95.8	94.8	0.87	593.0	7.7	1136.0	2.5	3.2	3.600	1745
375	E3BA355MLD2	2982	95.8	95.8	94.8	0.90	605.0	7.7	1201.0	1.6	3.1	6.520	2260

Efficiency values are measured according to IEC 60034-2-1; 2007, IS 15999(Part2/Sec1):2011  
Please note that the values are not comparable without knowing the testing method. ABB has calculated the efficiency values according to indirect method, stray load losses (additional losses) determined from measuring.

I<sub>s</sub> / I<sub>n</sub> = Starting current  
T<sub>s</sub> / T<sub>n</sub> = Locked rotor torque  
T<sub>b</sub> / T<sub>n</sub> = Breakdown

## Technical data

IE3 premium efficiency cast iron motors

Technical data for totally enclosed squirrel cage three phase induction motors

IP 55 - IC 411 - Insulation class F, temperature rise class B, IE3 efficiency class according to IEC 60034-30-1:2014, IS 12615:2018  
 4-Pole, TEFC, 415V, 50Hz, IP55, IC411, Ambt. 50 deg, Rise Class B (70 deg)

Output KW	Frame Size	Speed r/min	Efficiency			Power factor cos $\phi$	Current		Torque			Moment of inertia J=1/4GD <sup>2</sup> kgm <sup>2</sup>	Weight kg
			Full load 100%	3/4 load 75%	1/2 load 50%		I <sub>n</sub> , A	I <sub>s</sub> /I <sub>n</sub>	T <sub>n</sub> Nm	T <sub>s</sub> /T <sub>n</sub>	T <sub>b</sub> /T <sub>n</sub>		
1500 r/min = 4 poles			415V, 50Hz										
0.37	M2BAX71MLA4	1415	77.3	76.0	67.0	0.65	1.02	4.6	2.5	2.5	2.8	0.00098	12
0.55	M2BAX80MC4	1435	80.8	80.0	75.0	0.70	1.35	6.0	3.7	2.5	2.8	0.00195	17
0.75	M2BAX80MLA4	1445	82.5	81.1	77.1	0.70	2.05	4.5	5.0	3.5	3.9	0.00309	20
1.1	M2BAX90SB4	1435	84.1	83.7	81.0	0.70	2.60	6.0	7.3	3.0	3.7	0.00397	22
1.5	M2BAX90SLA4	1431	85.3	85.2	82.9	0.75	3.50	6.0	10.0	3.5	3.9	0.00486	25
2.2	M2BAX100LB4	1445	86.7	86.9	85.1	0.74	4.8	7.0	14.5	2.9	3.7	0.00919	34
3.7	M2BAX112MLA4	1450	88.4	88.5	87.0	0.76	7.7	7.5	24.4	3.3	3.9	0.01542	50
5.5	M2BAX132SMA4	1460	89.6	90.6	90.2	0.77	11.1	7.0	36.0	2.0	3.0	0.03505	72
7.5	M2BAX132MLA4	1462	90.4	90.9	90.3	0.75	15.4	7.0	48.8	2.1	3.2	0.04108	84
9.3	M2BAX160MLJ4	1470	91.0	90.9	89.5	0.77	18.5	7.5	60.4	2.7	3.5	0.105	130
11	M2BAX160MLA4	1470	91.4	91.5	90.5	0.78	21.6	7.5	71.5	2.6	3.2	0.11	134
15	M2BAX160MLB4	1470	92.1	92.2	91.3	0.80	28.8	7.5	97.4	2.6	3.4	0.135	159
18.5	M2BAX180MLA4	1475	92.6	93.0	92.5	0.80	34.7	7.5	119.8	2.5	3.3	0.219	192
22	M2BAX180MLB4	1475	93.0	93.5	93.0	0.79	41.5	7.5	142.4	2.9	3.5	0.243	205
30	M2BAX200MLA4	1480	93.6	93.8	93.2	0.83	54.0	7.5	193.6	2.9	3.3	0.385	259
37	M2ABX225SMA4	1480	93.9	94.2	93.8	0.80	68.5	7.5	238.8	2.8	3.2	0.427	274
45	M2BAX225SMB4	1480	94.2	94.6	94.3	0.81	82.5	7.5	290.4	2.5	3.1	0.525	307
55	M2BAX250SMA4	1482	94.6	94.7	94.1	0.82	99.0	7.5	354.4	2.6	3.0	0.694	358
75	M2BAX280SMB4	1485	95.0	95.0	94.0	0.83	133.0	7.7	482.0	2.3	2.8	1.38	597
90	M2BAX280SMC4	1485	95.2	95.2	94.2	0.83	159.0	7.7	579.0	2.5	2.9	1.73	659
110	M2BAX315SMB4	1489	95.4	95.4	94.4	0.82	196.0	7.7	705.0	2.1	3.0	2.43	881
132	M2BAX315SMC4	1488	95.6	95.6	94.6	0.85	226.0	7.7	847.0	2.2	2.9	2.9	955
160	M2BAX315SMD4	1488	95.8	95.8	94.8	0.84	276.0	7.7	1027.0	2.5	3.0	3.2	1000
200	M2BAX315MLB4	1488	96.0	96.0	95.0	0.84	343.0	7.7	1283.0	2.4	3.0	3.9	1153
250	M2BAX355SMA4	1491	96.0	96.0	95.0	0.83	435.0	7.7	1601.0	2.1	2.9	5.9	1534
315	M2BAX355SMB4	1491	96.0	96.0	95.0	0.83	548.0	7.7	2017.0	2.3	3.0	6.9	1685
355	M2BAX355SMC4	1486	96.0	96.0	95.0	0.84	612.0	7.7	2281.0	2.3	2.5	7.2	1730
400	E3BA355MLB4H	1486	96.0	96.0	95.0	0.86	674.0	7.7	2570.0	2.5	3.0	11.065	2430

Efficiency values are measured according to IEC 60034-2-1; 2007, IS 15999(Part2 Sec1):2011  
 Please note that the values are not comparable without knowing the testing method. ABB has calculated the efficiency values according to indirect method, stray load losses (additional losses) determined from measuring.

I<sub>s</sub> / I<sub>n</sub> = Starting current  
 T<sub>s</sub> / T<sub>n</sub> = Locked rotor torque  
 T<sub>b</sub> / T<sub>n</sub> = Breakdown

## Technical data

IE3 premium efficiency cast iron motors

Technical data for totally enclosed squirrel cage three phase induction motors

IP 55 - IC 411 - Insulation class F, temperature rise class B, IE3 efficiency class according to IEC 60034-30-1:2014, IS 12615:2018

6-Pole, TEFC, 415V, 50Hz, IP55, IC411, Ambt. 50 deg, Rise Class B (70 deg)

Output KW	Frame Size	Speed r/min	Efficiency			Power factor cos $\phi$	Current		Torque			Moment of inertia J=1/4GD <sup>2</sup> kgm <sup>2</sup>	Weight kg
			Full load 100%	3/4 load 75%	1/2 load 50%		I <sub>n</sub> , A	I <sub>s</sub> /I <sub>n</sub>	T <sub>n</sub> Nm	T <sub>s</sub> /T <sub>n</sub>	T <sub>b</sub> /T <sub>n</sub>		
1000 r/min = 6 poles			415V, 50Hz										
0.37	M2BAX80MC6	931	73.5	73.0	67.0	0.65	1.15	3.9	3.8	2.5	2.8	0.00220	15
0.55	M2BAX80MLA6	935	77.2	77.0	71.5	0.59	1.70	4.5	5.6	2.8	3.3	0.00349	19
0.75	M2BAX90SLA6	940	78.9	77.5	73.2	0.63	2.1	4.5	7.6	2.3	3.0	0.00487	25
1.1	M2BAX90LB6	945	81.0	79.7	75.4	0.61	3.1	4.5	11.1	3.0	3.6	0.00676	30
1.5	M2BAX100LKA6	954	82.5	82.6	80.2	0.67	3.8	4.5	15.0	2.2	2.4	0.00994	37
2.2	M2BAX112MLA6	952	84.3	84.4	82.5	0.66	5.5	5.0	22.1	1.9	2.7	0.01388	47
3.7	M2BAX132SMB6	960	86.5	87.0	86.0	0.68	8.8	5.0	36.8	1.6	2.7	0.03540	72
5.5	M2BAX132MLA6	965	88.0	88.3	87.3	0.68	12.7	5.0	54.4	1.6	2.8	0.05334	97
7.5	M2BAX160MLA6	965	89.1	90.2	90.0	0.72	16.2	6.5	74.2	1.8	3.1	0.089	119
9.3	M2BAX160MLJ6	970	89.8	90.3	89.7	0.70	20.6	6.5	91.5	1.9	3.1	0.128	153
11	M2BAX160MLB6	970	90.3	91.0	90.7	0.74	23.0	6.5	108.2	1.7	2.6	0.138	160
15	M2BAX180MLA6	972	91.2	91.6	91.0	0.72	31.8	6.0	147.3	1.8	2.8	0.212	190
18.5	M2BAX200MLA6	980	91.7	91.8	90.9	0.80	35.0	7.0	180.2	2.2	3.1	0.496	238
22	M2BAX200MLB6	986	92.2	92.2	91.1	0.79	42.3	7.5	213.0	2.3	3.4	0.585	263
30	M2BAX225SMA6	982	92.9	93.0	92.0	0.76	59.0	7.5	291.6	2.3	3.0	0.724	285
37	M2BAX250SMA6	985	93.3	93.7	93.4	0.80	69.3	7.0	358.6	2.1	2.5	1.3	379
45	M2BAX280SMB6	991	93.7	93.7	91.7	0.77	87.0	7.7	434.0	2.7	3.0	1.87	584
55	M2BAX280SMC6	993	94.1	94.1	92.1	0.80	102.0	7.7	529.0	2.8	3.0	2.57	640
75	M2BAX315SMB6	994	94.6	94.6	92.6	0.83	133.0	7.7	720.0	1.8	2.6	4.1	885
90	M2BAX315SMC6	994	94.9	94.9	92.9	0.82	160.0	7.7	865.0	2.0	3.0	4.6	967
110	M2BAX315SMD6	994	95.1	95.1	93.1	0.82	196.0	7.7	1057.0	2.2	3.0	4.9	1026
132	M2BAX315MLB6	995	95.4	95.4	93.4	0.81	238.0	7.7	1267.0	2.3	2.7	6.3	1196
160	M2BAX355SMA6	993	95.6	95.6	93.6	0.80	291.0	7.7	1539.0	2.5	2.6	7.9	1433
200	M2BAX355SMB6	993	95.8	95.8	93.8	0.79	367.0	7.7	1923.0	2.1	2.5	9.7	1597
250	M2BAX355SMC6	988	95.8	95.8	93.8	0.79	460.0	7.7	2416.0	3.0	3.1	11.3	1675
275	E3BA355MLB6K	990	95.8	95.8	93.8	0.84	475.0	7.7	2653.0	1.4	2.6	15.975	2250
315	E3BA355MLB6	990	95.8	95.8	93.8	0.84	545.0	7.7	3039.0	2.3	2.8	15.975	2250
355	E3BA355MLB6H**	990	95.8	95.8	93.8	0.84	614.0	7.7	3424.0	1.3	2.7	15.975	2250

\*\* Temp. Rise Class F

Efficiency values are measured according to IEC 60034-2-1; 2007, IS 15999(Part2 Sec1):2011  
Please note that the values are not comparable without knowing the testing method. ABB  
has calculated the efficiency values according to indirect method, stray load losses  
(additional losses) determined from measuring.

I<sub>s</sub> / I<sub>n</sub> = Starting current  
T<sub>s</sub> / T<sub>n</sub> = Locked rotor torque  
T<sub>b</sub> / T<sub>n</sub> = Breakdown

## Technical data

IE3 premium efficiency cast iron motors

Technical data for totally enclosed squirrel cage three phase induction motors

IP 55 - IC 411 - Insulation class F, temperature rise class B, IE3 efficiency class according to IEC 60034-30-1:2014, IS 12615:2018  
8-Pole, TEFC, 415V, 50Hz, IP55, IC411, Ambt. 50 deg, Rise Class B (70 deg)

Output KW	Frame Size	Speed r/min	Efficiency			Power factor cos $\phi$	Current		Torque			Moment of inertia J=1/4GD <sup>2</sup> kgm <sup>2</sup>	Weight kg
			Full load 100%	3/4 load 75%	1/2 load 50%		I <sub>n</sub> , A	I <sub>s</sub> /I <sub>n</sub>	T <sub>n</sub> Nm	T <sub>s</sub> /T <sub>n</sub>	T <sub>b</sub> /T <sub>n</sub>		
750 r/min = 8 poles			415V, 50Hz										
0.12	M2BAX71MB8	680	50.7	44.9	35.8	0.51	0.65	3.0	1.7	2.6	2.7	0.0011	12
0.18	M2BAX80MA8	700	58.7	53.5	42.6	0.56	0.76	3.0	2.5	2.5	2.8	0.0019	16
0.25	M2BAX80MB8	690	64.1	60.3	51.7	0.57	0.95	3.0	3.5	2.3	2.4	0.0024	17
0.37	M2BAX90SA8	697	69.3	66.2	57.1	0.55	1.35	4.5	5.1	2.2	2.6	0.0044	23
0.55	M2BAX90LA8	672	73	71	66	0.59	1.8	3.0	7.8	1.7	1.9	0.0075	30
0.75	M2BAX100LKA8	695	75	72.2	63.8	0.64	2.2	4.0	10.3	2.2	2.6	0.0096	35
1.1	M2BAX100LKB8	695	77.7	77.5	73.1	0.62	3.2	4.0	15.1	2.0	2.2	0.0113	38
1.5	M2BAX112MLA8	680	79.7	78.7	73.7	0.66	4.0	4.0	21.1	1.8	2.1	0.0146	47
2.2	M2BAX132SMA8	715	81.9	80.9	76.4	0.61	6.1	5.0	29.4	1.7	2.4	0.0362	81
3.7	M2BAX160MLA8	715	84.5	84.5	83.5	0.63	9.7	5.0	49.4	1.7	2.5	0.0689	107
5.5	M2BAX160MLB8	725	86.2	86.2	85.2	0.63	14.1	5.0	72.4	1.7	2.5	0.0940	127
7.5	M2BAX160MLC8	725	87.3	87.3	86.3	0.63	19.0	5.0	98.8	1.7	2.5	0.1230	150
9.3	M2BAX180MLA8	730	88.1	88.1	86.7	0.61	24.1	5.6	121.7	1.9	2.9	0.2140	208
11	M2BAX180MLB8	730	88.6	88.6	87.5	0.67	26.0	5.6	143.9	1.5	2.4	0.2280	216
15	M2BAX200MLA8	736	89.6	89.6	89.2	0.71	32.8	5.6	194.6	2.0	2.4	0.4960	238
18.5	M2BAX225SMA8	738	90.1	90.1	90.0	0.72	39.7	5.2	239.4	2.0	2.3	0.6570	271
22	M2BAX225SMB8	738	90.6	90.6	90.2	0.72	46.9	5.5	284.7	2.0	2.3	0.7240	290
30	M2BAX250SMA8	740	91.3	91.3	91.0	0.69	66.3	5.5	387.2	1.9	2.5	1.3000	379
37	M2BAX280SA8	741	91.8	91.8	89.8	0.72	78.0	7.7	477.0	1.8	3.0	1.8500	558
45	M2BAX280SB8	742	92.2	92.2	90.2	0.75	90.0	7.7	579.0	1.8	3.0	2.2000	598
55	M2BAX315SMA8	743	92.5	92.5	90.5	0.75	110.0	7.7	707.0	1.7	2.9	3.2000	792
75	M2BAX315SMB8	742	93.1	93.1	91.1	0.78	144.0	7.7	966.0	1.8	2.9	4.1000	880
90	M2BAX315SMC8	742	93.4	93.4	91.4	0.78	172.0	7.7	1159.0	1.8	2.9	4.9000	959
110	M2BAX315MLA8	743	93.7	93.7	91.7	0.8	204.0	7.7	1414.0	1.8	2.9	5.8000	1091
132	M2BAX355SMA8	745	94	94	92	0.75	260.0	7.7	1692.0	1.6	2.7	7.9000	1413
160	M2BAX355SMB8	744	94.3	94.3	92.3	0.75	315.0	7.7	2054.0	1.7	2.8	9.7000	1574
200	M2BAX355SMC8	745	94.6	94.6	92.6	0.77	382.0	7.7	2563.0	1.7	2.8	11.3000	1600
225	E3BA355MLB8H	740	94.6	94.6	92.6	0.77	429.7	7.0	2904.0	1.7	2.6	16.0500	2100
250	E3BA355MLB8k**	740	94.6	94.6	92.6	0.81	453.9	7.0	3226.0	1.6	2.6	16.5000	2225

\*\* Temp. Rise Class F

Efficiency values are measured according to IEC 60034-2-1; 2007,IS 15999(Part2 Sec1):2011  
Please note that the values are not comparable without knowing the testing method. ABB has calculated the efficiency values according to indirect method, stray load losses (additional losses) determined from measuring.

I<sub>s</sub> / I<sub>n</sub> = Starting current  
T<sub>s</sub> / T<sub>n</sub> = Locked rotor torque  
T<sub>b</sub> / T<sub>n</sub> = Breakdown

## Dimension drawings

### General performance IE3 premium efficiency cast iron motors

Foot-mounted motor IM1001, B3

Flange-mounted motor IM3001, B5

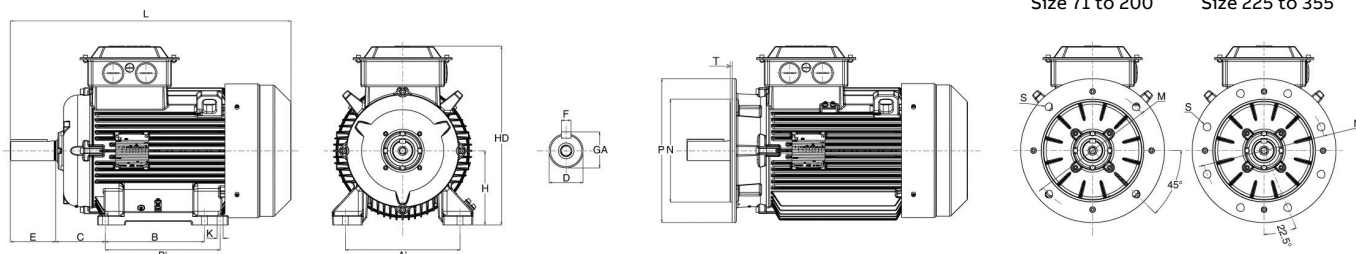

Motor Size	D Poles		GA Poles		F Poles		E Poles		L max Poles		A	B	B'	C	HD	K	H	M	N	P	S	T
	2	4-8	2	4-8	2	4-8	2	4-8	2	4-8												
<b>General performance cast iron motors</b>																						
71M	14	14	16.0	16.0	5	5	30	30	257	257 <sup>2)</sup>	112	90	-	45	175	7	71	130	110	160	10	3.5
80M	19	19	21.5	21.5	6	6	40	40	309	309	125	100	-	50	192	10	80	165	130	200	12	3.5
80ML	19	19	21.5	21.5	6	6	40	40	334	334	125	100	112	50	192	10	80	165	130	200	12	3.5
90S	24	24	27.0	27.0	8	8	50	50	335	335	140	100	-	56	217	10	90	165	130	200	12	3.5
90SL	24	24	27.0	27.0	8	8	50	50	351	351	140	100	125	56	217	10	90	165	130	200	12	3.5
90L	24	24	27.0	27.0	8	8	50	50	386	386	140	-	125	56	217	10	90	165	130	200	12	3.5
100L	28	28	31.0	31.0	8	8	60	60	376	376	160	140	-	63	240	12	100	215	180	250	15	4.0
100LK	28	28	31.0	31.0	8	8	60	60	410	410	160	140	160	63	240	12	100	215	180	250	15	4.0
112M	28	28	31.0	31.0	8	8	60	60	411	411	190	140	-	70	252	12	112	215	180	250	15	4.0
112ML	28	28	31.0	31.0	8	8	60	60	456	456	190	140	159	70	252	12	112	215	180	250	15	4.0
132SM	38	38	41.0	41.0	10	10	80	80	521	521	216	140	178	89	301	12	132	265	230	300	15	4.0
132ML	38	38	41.0	41.0	10	10	80	80	586	586	216	178	203	89	301	12	132	265	230	300	15	4.0
160ML	42	42	45.0	45.0	12	12	110	110	639 <sup>1)</sup>	639 <sup>1)</sup>	254	210	254	108	414	14.5	160	300	250	350	19	5.0
180ML	48	48	51.5	51.5	14	14	110	110	728	728	279	241	279	121	454	14.5	180	300	250	350	19	5.0
200ML	55	55	59.0	59.0	16	16	110	110	809	809	318	267	305	133	515	18.5	200	350	300	400	19	5.0
225SM	55	60	59.0	64.0	16	18	110	140	812	842	356	286	311	149	560	18.5	225	400	350	450	19	5.0
250SM	60	65	64.0	69.0	18	18	140	140	853	853	406	311	349	168	613	24	250	500	450	550	19	5.0
280S	65	75	69.0	79.5	18	20	140	140	982	982	457	368	-	190	775	24	280	500	450	550	19	5.0
280SM	65	75	69.0	79.5	18	20	140	140	1052	1052	457	368	419	190	775	24	280	500	450	550	19	5.0

Motor	D		GA		F		E		L Max		A	B	B'	C	HD	K	H	M	N	P	S	T
	2	4_8	2	4_8	2	4_8	2	4_8	2	4_8												
M2BAX 315SM	65	80	69.0	85.0	18	22	140	170	1216	1246	508	406	457	216	872	28	315	600	550	660	24	6.0
M2BAX 315ML	65	90	69.0	95.0	18	25	140	170	1326	1356	508	457	508	216	872	28	315	600	550	660	24	6.0
M2BAX 355SM	70	100	74.5	106.0	20	28	140	210	1399	1469	610	500	560	254	960	35	355	740	680	800	24	6.0
E3BA 355MLB8K	-	100	-	106.0	-	28	-	210	-	1680	610	560	630	254	965	28	355	740	680	800	24	6.0
E3BA 355MLB4H	-	100	-	106.0	-	28	-	210	-	1680	610	560	630	254	995	28	355	740	680	800	24	6.0
E3BA 355MLD2	75	-	79.5	-	20	-	140	-	1610	-	610	560	630	254	995	28	355	740	680	800	24	6.0
E3BA 355MLB6H	-	100	-	106.0	-	28	-	210	-	1680	610	560	630	254	995	28	355	740	680	800	24	6.0
E3BA 355MLB6/B6K	-	100	-	106.0	-	28	-	210	-	1680	610	560	630	254	965	28	355	740	680	800	24	6.0
E3BA355MLB8H	-	100	-	106.0	-	28	-	210	-	1574	610	560	630	254	965	28	355	740	680	800	24	6.0

Above table gives the main dimensions in mm.

1) M2BAX 160ML C2, B4, J6, B6: L = 696  
 2) M2BAX 71ML A4: L = 282

## Motors in brief

General performance IE3 premium efficiency cast iron motors in brief

Size	71	80	90	100	112	132	
<b>Stator</b>	Material	Cast Iron Grade 150:ISO 185					
	Paint colour shade	Munsell blue 8B 4.5/3.25 / NCS 4822 B05G					
	Surface Treatment	C3 medium according to ISO / EN 12944-5					
<b>Feet</b>		Integrated with stator					
	Material	Cast iron grade 150 : ISO 185					
<b>Bearing end shields</b>	Material	Cast iron grade 150 : ISO 185					
	Paint colour shade	Munsell blue 8B 4.5/3.25/NCS 4822 B05G					
	Surface Treatment	C3 medium according to ISO / EN 12944-5					
<b>Bearings</b>	D-end	6203-2Z/C3	6204-2Z/C3	6205-2Z/C3	6206-2Z/C3	6206-2Z/C3	6208-2Z/C3
	N-end	6202-2Z/C3	6203-2Z/C3	6204-2Z/C3	6205-2Z/C3	6205-2Z/C3	6208-2Z/C3
<b>Axially-locked</b>	Retaining Ring	As standard, locked at D-end					
<b>Bearing seals</b>		Axial seal as standard, radial on request					
<b>Lubrication</b>		Permanently lubricated shielded bearings					
<b>Rating plate</b>	Material	Aluminium					
<b>Terminal Box</b>	Frame material	Cast Iron, Integral to stator frame					
	Cover material	Sheet of steel, Cold rolled					
	Cover screws material	Steel 8.8					
<b>Connections</b>	Cable entries	2xM16	2xM25	2xM32			
	Cable Sizes	2Rx3Cx4mm <sup>2</sup>	2Rx3Cx6mm <sup>2</sup>	2Rx3Cx10mm <sup>2</sup>			
	Terminal Stud Size	M4	M4	M5			
	Terminals	Upto 2HP- STAR / 3 Leads > 2 HP- DELTA / 6 Leads (Cable lugs not included)					
<b>Fan</b>	Material	Polypropylene, Reinforced with 20% glass fibre					
<b>Fan Cover</b>	Material	Sheet of steel, cold rolled					
	Paint Colour shade	Munsell blue 8B 4.5/3.25/NCS 4822 B05G					
	Surface Treatment	C3 medium according to ISO/EN 12944-5					
<b>Stator winding</b>	Material	Copper					
	Insulation	Insulation class F, Temperature rise class B unless otherwise stated					
	Winding protection	-					
<b>Rotor winding</b>	Material	Pressure diecast aluminum					
<b>Balancing method</b>		Half Key Balancing as Standard					
<b>Key ways</b>		Open Key Way					
<b>Enclosure</b>		IP 55, Higher protection on request					
<b>Cooling method</b>		IC 411					
<b>Drain holes</b>		Drain holes with closable plastic plugs, open on delivery					
<b>Lifting lugs</b>		Integrated with the stator					

## Motors in brief

General performance IE3 premium efficiency cast iron motors in brief

Size		160	180	200	225	250
<b>Stator</b>	Material	Cast Iron Grade 200:ISO 185				
	Paint colour shade	Munsell blue 8B 4.5/3.25 / NCS 4822 B05G				
	Surface Treatment	C3 medium according to ISO / EN 12944-5				
<b>Feet</b>		Integrated with stator				
	Material	Cast iron grade 200 : ISO 185				
<b>Bearing end shields</b>	Material	Cast iron grade 200 : ISO 185				
	Paint colour shade	Munsell blue 8B 4.5/3.25/NCS 4822 B05G				
	Surface Treatment	C3 medium according to ISO / EN 12944-5				
<b>Bearings</b>	D-end	6209-2Z/C3	6310-2Z/C3	6312-2Z/C3	6313-2Z/C3	6315-2Z/C3
	N-end	6209-2Z/C3	6209-2Z/C3	6209-2Z/C3	6210-2Z/C3	6212-2Z/C3
<b>Axially-locked</b>	Inner Bearing Cover	As standard, locked at D-end				
<b>Bearing seals</b>		Axial seal standard, radial on request				
<b>Measuring nipple</b>		Not included				
<b>Lubrication</b>		Permanently lubricated shielded bearings				
<b>Rating plate</b>	Material	Aluminium				
<b>Terminal Box</b>	Frame material	Sheet of Steel, cold rolled				
	Cover material	Sheet of Steel, cold rolled				
	Cover screws material	Steel 8.8				
<b>Connections</b>	Cable entries	2xM40, 1xM16		2xM50, 1xM16		
	Cable Sizes	2Rx3Cx70mm <sup>2</sup>		2Rx3Cx120mm <sup>2</sup>		
	Terminal Stud Size	M6		M10		
	Terminals	6 terminals for connection, Cable lugs not included				
<b>Fan</b>	Material	Polypropylene, Reinforced with 20% glass fibre				
<b>Fan Cover</b>	Material	Sheet of steel, cold rolled				
	Paint Colour shade	Munsell blue 8B 4.5/3.25/NCS 4822 B05G				
	Surface Treatment	C3 medium according to ISO/EN 12944-5				
<b>Stator winding</b>	Material	Copper				
	Insulation	Insulation class F, Temperature rise class B unless otherwise stated.				
	Winding protection	-				
<b>Rotor winding</b>	Material	Pressure diecast aluminium				
<b>Balancing method</b>		Half Key Balancing as Standard				
<b>Key ways</b>		Open Key Way				
<b>Enclosure</b>		IP 55, Higher protection on request				
<b>Cooling method</b>		IC 411				
<b>Drain holes</b>		Drain holes with closable plastic plugs, open on delivery				
<b>Lifting lugs</b>		Integrated with the stator				

## Motors in brief

General performance IE3 premium efficiency cast iron motors in brief

Size		280 2-8 Pole	315 2 Pole	315 4-8 Pole	355 2 Pole	355 4-8 Pole
<b>Stator</b>	Material	Cast iron grade 150, IS:210 <sup>1)</sup>				
	Paint colour shade	Munsell blue 8B 4.5/3.25 / NCS 4822 B05G				
	Surface Treatment	C3 medium according to ISO / EN 12944-5				
<b>Feet</b>		Integrated with stator				
	Material	Cast iron grade 150, IS:210 <sup>1)</sup>				
<b>Bearing end shields</b>	Material	Cast iron grade 150, IS:210 <sup>1)</sup>				
	Paint colour shade	Munsell blue 8B 4.5/3.25 / NCS 4822 B05G				
	Surface Treatment	C3 medium according to ISO / EN 12944-5				
<b>Bearing</b>	D-end	6316/C3	6316/C3	6319/C3	6319/C3 <sup>2)</sup>	6322/C3
	N-end	6316/C3	6316/C3	6316/C3	6319/C3 <sup>2)</sup>	6319/C3 <sup>2)</sup>
<b>Axially-locked</b>	Inner Bearing Cover	As standard, locked at D-end				
<b>Lubrication</b>		Regreasable Bearings, Regreasing nipple M10X1				
<b>Measuring nipple</b>		-				
<b>Rating plate</b>	Material	Stainless Steel				
<b>Terminal Box</b>	Frame material	Cast iron grade 150, IS:210 <sup>1)</sup>				
	Cover Material	Cast iron grade 150, IS:210 <sup>1)</sup>				
	Screws	Steel				
<b>Connections</b>	Cable Entries	2 x 2" BSC <sup>3)</sup>		2 x 2-1/2" BSC* <sup>3)</sup>		
	Cable Sizes	280 : 2Rx3Cx185Sqmm Cu/Al Cable 315 : 2Rx3Cx240Sqmm Cu/Al Cable 355 : 2Rx3Cx240Sqmm Cu/Al Cable*				
	Terminal Stud Size	M12		M16 <sup>4)</sup>		
	Terminal Box	6 terminals for connection, Cable lugs not included				
	<b>Fan</b>	Material	Polypropylene, Reinforced Aluminium <sup>5)</sup> with 20% glass fibre			
<b>Fan Cover</b>	Material	Sheet of steel, Cold Rolled				
	Paint colour shade	Munsell blue 8B 4.5/3.25 / NCS 4822 B05G				
	Surface Treatment	C3 medium according to ISO / EN 12944-5				
<b>Stator winding</b>	Material	Copper				
	Insulation	Insulation class F, Temperature rise class B unless otherwise stated				
	Winding protection	-				
<b>Rotor winding</b>	Material	Pressure diecast aluminum				
<b>Balancing method</b>		Half Key Balancing as standarad				
<b>Key ways</b>		Open Key Way				
<b>Enclosure</b>		IP 55				
<b>Cooling method</b>		IC 411				
<b>Drain holes</b>		Drain holes with closable plastic plugs, open on delivery				
<b>Lifting lugs</b>		Bolted to the Stator				

\*Cable Size for 355MLD2, 355MLB6H & 355MLB4H will be 2Rx3Cx300 Sqmm Cu/Al , Threaded opening 2x3" BSC

For M2BAX series, following is applicable:

- 1) Cast Iron Grade 200, IS:210
  - 2) Bearing Size: 6316/C3
  - 3) Cable Entries for
    - 280 to 315 frame - 2xM63, 2xM20
    - 355 frame - 2xM75, 2xM20
  - 4) Terminal Stud Size: M12
  - 5) For all Frames,fan material is Polypropylene,Reinforced with 20% glass fibre.
- \*\*\*Bearings Seals in M2BAX 280 to 355 frame is V-ring at DE and NDE side.

---

**ABB India Limited**

32, Industrial Area,  
N.I.T., Faridabad - 121 001  
Tel: +91 129 2448100

**[www.abb.co.in](http://www.abb.co.in)**

We reserve the right to make technical changes or modify the contents of this document without prior notice. With regard to purchase orders, the agreed particulars shall prevail. ABB does not accept any responsibility whatsoever for potential errors or possible lack of information in this document.

We reserve all rights in this document and in the subject matter and illustrations contained therein. Any reproduction, disclosure to third parties or utilization of its content - in whole or in parts - is forbidden without ABB's prior written consent.



---

## Low Voltage

IE4 Super Premium Efficiency  
Cast iron motors



---

**With expertise and a comprehensive portfolio of products and life-cycle services, we help value-minded industrial customers improve their energy efficiency and productivity.**

---

# IE4 efficiency cast iron motors sizes 71 to 355

<b>04-05</b>	<b>International motor efficiency standards and regulations</b>	<b>13-14</b>	<b>Technical data general performance motors</b>
<b>06</b>	<b>Implementation of IS 12615</b>	<b>15</b>	<b>Technical data process performance motors</b>
<b>07</b>	<b>Motors with variable speed drives</b>	<b>16-17</b>	<b>Dimension drawings</b>
<b>08</b>	<b>Payback Calculations</b>	<b>18-20</b>	<b>Motors in brief</b>
<b>09</b>	<b>Mounting arrangements</b>	<b>21</b>	<b>Product note IE4 efficiency cast iron motors</b>
<b>10</b>	<b>General information on cooling</b>	<b>22</b>	<b>ABB Ability™ Smart Sensor</b>
<b>11</b>	<b>General information on degrees of protection &amp; Insulation</b>		
<b>12</b>	<b>General information on voltage and frequency</b>		

# International motor efficiency standards and regulations

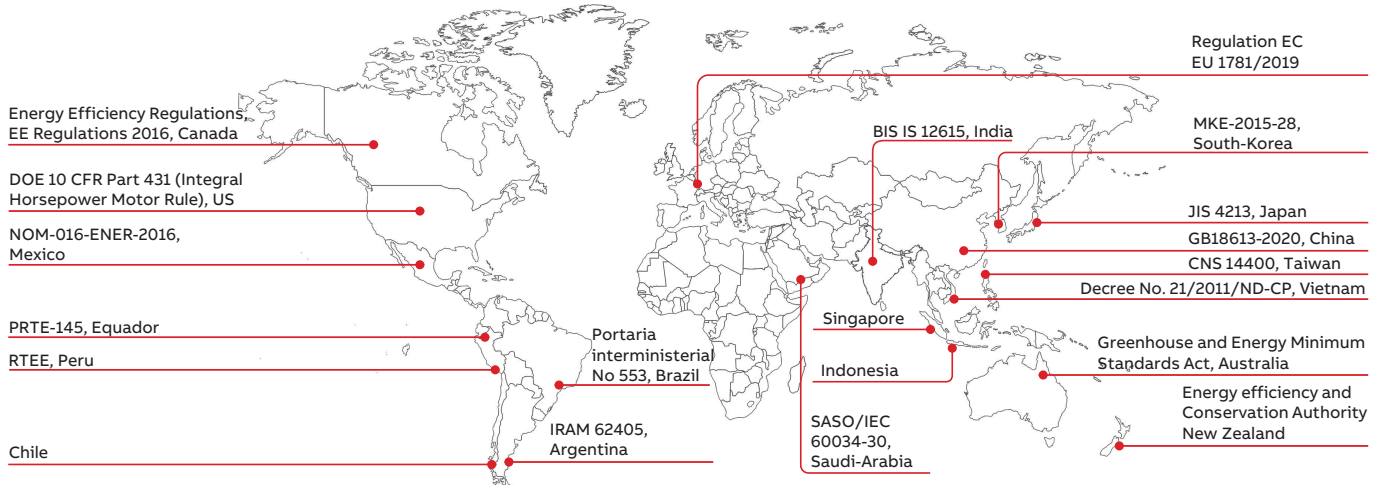

Since the validation of IEC 60034-30:2008 and its refined version IEC 60034-30-1:2014, a worldwide energy efficiency classification system has existed for low voltage three-phase asynchronous motors. These international standards have been created to enable and increase the level of harmonization in efficiency regulations around the world and to also cover motors for explosive atmospheres.

IEC 60034-30-1:2014 defines International Efficiency (IE) classes for single speed, three-phase, 50 Hz and 60 Hz induction motors. The efficiency levels defined in IEC 60034-30-1 are based on the test method specified in IEC 60034-2-1:2014. Both standards are part of an effort to unify motor testing procedures with CSA390-10 and IEEE 112 standards as well as efficiency and product labeling (IE) requirements to enable motor purchasers worldwide to easily recognize premium efficiency products.

To promote transparency in the market, IEC 60034-30-1 states that both the efficiency class and efficiency value must be shown on the motor rating plate and in product documentation. The documentation must clearly indicate the efficiency testing method used as different methods can produce differing results.

## Minimum energy performance standards

While the IEC as an international standardization organization sets guidelines for motor testing and efficiency classes, the organization does not regulate efficiency levels in countries. The biggest drivers for mandatory Minimum Energy Performance Standard (MEPS) levels for electric motors are global climate change, government targets to curb CO<sub>2</sub> emissions and rising electricity demand, especially in developing countries. The whole value chain, from manufacturer up to end user, must be aware of the legislation in order to meet local requirements, to save energy and reduce the carbon footprint.

Harmonized global standards and the increasing adoption of MEPS around the world are good news for all of us. However, it is important to remember that harmonization is an ongoing process. Even though MEPS are already in effect in several regions and countries, they are evolving and differ in terms of scope and requirements. At the same time, more countries are planning to adopt their own MEPS regulations. A view of existing and coming MEPS regulations in the world can be seen on the World map above.

To get the latest information please visit [new.abb.com/motors-generators/energy-efficiency](http://new.abb.com/motors-generators/energy-efficiency).

**IEC 60034-30-1:2014**

This standard defines four International Efficiency (IE) classes for single speed electric motors that are rated according to IEC 60034-1 or IEC 60079-0 (explosive atmospheres) and designed for operation on sinusoidal voltage.

- IE4 = Super premium efficiency
- IE3 = Premium efficiency, identical to the table in 10CFR431 ('NEMA Premium') in the USA and CSA C390-10:2015 for 60 Hz
- IE2 = High efficiency
- IE1 = Standard efficiency

IEC 60034-30-1 covers the power range from 0.12 kW up to 1000 kW. Most of the different technical constructions of electric motors are covered as long as they are rated for direct on-line operation. The coverage of the standard includes:

- Single speed electric motors (single and three-phase), 50 and 60 Hz
- 2, 4, 6 and 8 poles
- Rated output  $P_N$  from 0.12 kW to 1000 kW
- Rated voltage  $U_N$  above 50 V up to 1 kV
- Motors capable of continuous operation at their rated power with a temperature rise within the specified insulation temperature class
- Motors, marked with any ambient temperature within the range of  $-20\text{ }^\circ\text{C}$  to  $+60\text{ }^\circ\text{C}$
- Motors, marked with an altitude up to 4000 m above sea level

By comparing IEC 60034-30-1 to CSA C390-10:2015 and "10CFR431 Subpart B – Electric motors", it can be seen that the efficiency limits and tables are well aligned and their major difference is in the scope of the output power where CSA and 10CFR431 have a maximum power of 500 hp. There are also some minor differences in the scope of excluded motors.

Note: CFR is Code of Federal Regulations.

The following motors are excluded from IEC 60034-30-1:

- Single-speed motors with 10 or more poles or multi-speed motors
- Motors completely integrated into a machine (for example pump, fan or compressor) that cannot be tested separately from the machine
- Brake motors, when the brake cannot be dismantled or separately fed

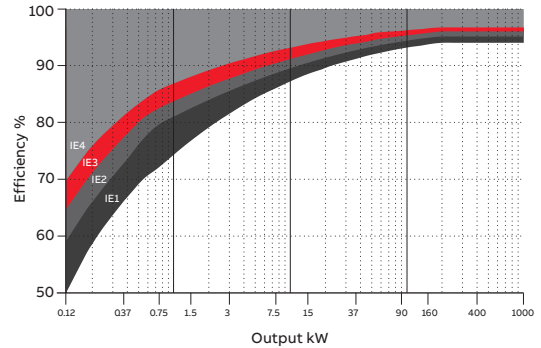

01

**ABB and efficiency standards**

ABB determines efficiency values according to IEC 60034-2-1 using the low uncertainty method (i.e. summation of losses), with additional load losses determined by the method of residual loss.

It is good to mention and emphasize that the IEC 60034-2-1 test method, which is known as an indirect method, is technically equivalent to the test methods in the standards CSA 390-10 and IEEE 112 Method B leading to the equivalent losses and thus efficiency values. Both test methods can be used by ABB and shall be used for both Canada and the US where IEC 60034-2-1 is not recognized yet.

As the world market leader, ABB offers the largest range of low voltage motors available. It has long advocated the need for efficiency in motors, and high efficiency products have formed the core of its portfolio for many years.

# Green Initiative by Implementation of IS 12615

Considering MEPS initiatives world wide and to reduce carbon foot print ,Government of India has released a Gazette for IS 12615 as mandatory requirement for Line Operated Three Phase a.c motors.



This initiative was taken considering Electric motors are the most important type of electric load in every industry. The motor driven systems account for about seventy percent of the energy consumed by the industry. There is a large potential for cost effective solution in the use of energy efficient motor systems by about 20-30%. Electric motor systems include a number of energy using products, such as motors, drives, pumps or fans, compressors, blowers and other machines. Energy efficient motors form a major component in contributing to the energy saving by way of increased efficiency of the product itself .

Acknowledging the need for energy saving in view of the energy scarcity, climate change mitigations and the potential that exists with energy efficient motors, Government of India by releasing Gazette withdraw lower efficiency classes and adopt higher efficiency class motors as per IS 12615 thus defining minimum efficiency performance standards IE2 level in country.

This standard covers the efficiency classes and performance specifications of single-speed line operated a.c. motors that are rated according to IS 15999 (Part 1)/IEC 60034-1, rated for operation on a sinusoidal voltage supply.

# ABB IEC Low Voltage motors with variable speed drives

Variable speed drives (VSD) provide significant benefits when used together with ABB IEC Low Voltage motors. The advantages include better process control and energy savings through a regulation of motor speed, and smooth starting with a reduced inrush current, reducing the stress on the equipment and supply network

Winding insulation, to ensure that motors operate reliably, the effects of non-sinusoidal output voltages from the converter must be taken into consideration when selecting the correct insulation system for the motor and output filters for the drive. The insulation and filters must be selected according below Table 1

to ensure trouble free operation of motors.

Winding Insulation and filters required	
$U_N \leq 500V$	Standard Insulation
$U_N \leq 600V$	Standard Insulation + dU/dt filters OR Special insulation (variant code 405)
$U_N \leq 690V$	Special Insulation (variant code 405) AND dU/dt-filters at converter output
$600V < U_N \leq 690V$ cable length > 150 m	Special Insulation (variant code 405)

**Table 1**

UN Rated motor terminal voltage

# Payback Calculations

Benefits of moving towards energy efficient motors can be examined when we are comparing same kW of motors with different efficiency level such as IE4, IE3 and IE2 efficiency level.

The same can be illustrated by considering 55KW, 4P, 50Hz motor

Efficiency value defined by Indian Standard for 55kw, 4Pole motor

IE2 – 93.5%, IE3 – 94.6%, IE4 – 95.7 %

Assumptions- Motor is running continuously for 24 hrs, 365 days operations ,while Per unit Electricity- Rs 10

Parameter	IE2	IE3	IE4
Rated Power (kW)	55	55	55
Full load efficiency	93.5%	94.6%	95.7%
Input Power(Rated KW/Eff.)	58.82	58.14	57.47
Operations(24*365)		8760	
Energy consumption per year (Input power*Operations)	515294	509302	503448
Energy Saving(kWh) IE2 to IE3 per year	515294 - 509302 = 5992		
Energy Saving(kWh) IE3 to IE4 per year	509302 - 503448 = 5854		
Energy Saving(kWh) IE4 to IE2 per year	515294 - 503448 = 11846		
Annual reduction in Energy bill from IE2 to IE3	5992*10 = 59,920 INR		
Annual reduction in Energy bill from IE3 to IE4	5854*10 = 58,540 INR		
Annual reduction in Energy bill from IE4 to IE2	11846*10 = 118,460 INR		

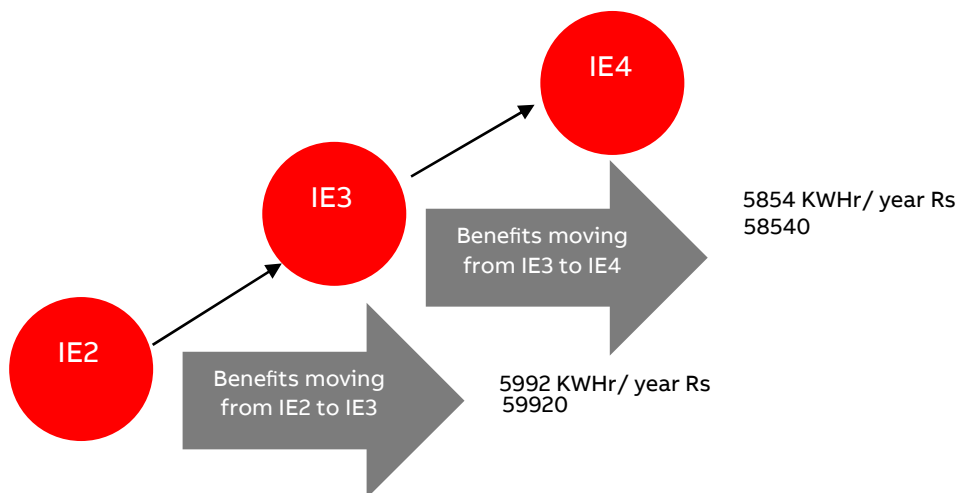

User get maximum benefit if they directly Opt for IE4 motors. To start with, one motor can start the movement

# Mounting arrangements

## Foot-mounted motor

Code I / code II

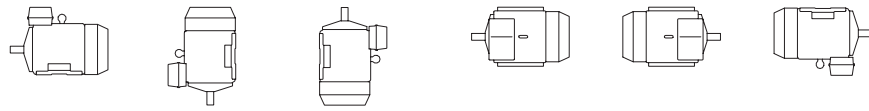

IM B3	IM V5	IM V6	IM B6	IM B7	IM B8
IM 1001	IM 1011	IM 1031	IM 1051	IM 1061	IM 1071

Product code pos. 12

A: foot-mounted, term. box top  
 R: foot-mounted, term. box RHS  
 L: foot-mounted, term. box LHS

## Flange-mounted motor, large flange

Code I / code II

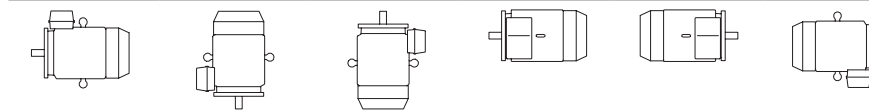

IM B5	IM V1	IM V3	*)	*)	*)
IM 3001	IM 3011	IM 3031	IM 3051	IM 3061	IM 3071

Product code pos. 12

B: flange mounted, large flange

## Flange-mounted motor, small flange

Code I / code II

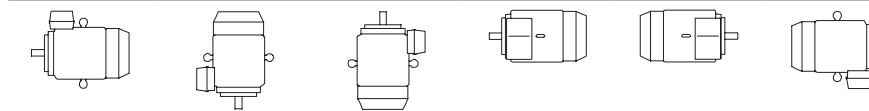

IM B14	IM V18	IM V19	*)	*)	*)
IM 3601	IM 3611	IM 3631	IM 3651	IM 3661	IM 3671

Product code pos. 12

C: flange mounted, small flange

## Foot- and flange-mounted motor with feet, large flange

Code I / code II

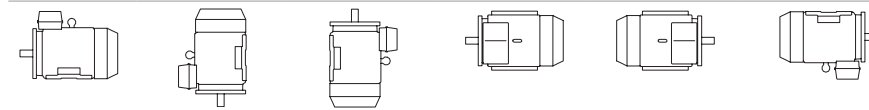

IM B35	IM V15	IM V35	*)	*)	*)
IM 2001	IM 2011	IM 2031	IM 2051	IM 2061	IM 2071

Product code pos. 12

H: foot/flange-mounted, term. box top  
 S: foot/flange-mounted, term. box RHS  
 T: foot/flange-mounted, term. box LHS

## Foot- and flange-mounted motor with feet, small flange

Code I / code II

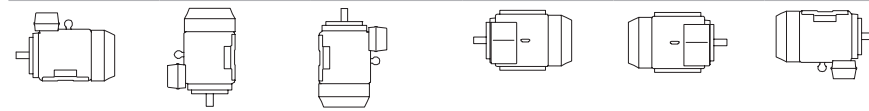

IM B34	IM V17				
IM 2101	IM 2111	IM 2131	IM 2151	IM 2161	IM 2171

Product code pos. 12

J: foot/flange-mounted, small flange

## Foot-mounted motor, shaft with free extensions

Code I / code II

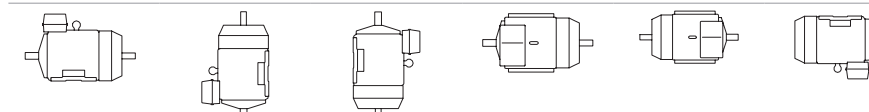

IM 1002	IM 1012	IM 1032	IM 1052	IM 1062	IM 1072
---------	---------	---------	---------	---------	---------

Product code pos. 12

\*) Not stated in IEC 60034-7.

Note: If the motor is mounted shaft upwards, take measures to prevent water or any other liquid from running down the shaft into the motor.

# General information

## Cooling

Designation system concerning methods of cooling refers to standard IS 6362 / IEC 60034-6.

### Explanation of the product code

International Cooling	Circuit arrangement	Primary coolant	Method of movement of primary coolant	Secondary coolant	Method of movement of secondary coolant
IC	4	(A)	1	(A)	6
	1	2	3	4	5

#### Position 1

0:	Free circulation (open circuit)
4:	Frame surface cooled

#### Position 2

A:	For air (omitted for simplified designation)
----	----------------------------------------------

#### Position 3

0:	Free convection
1:	Self-circulation
6:	Machine-mounted independent component

#### Position 4

A:	For air (omitted for simplified designation)
W:	For water

#### Position 5

0:	Free convection
1:	Self-circulation
6:	Machine-mounted independent component
8:	Relative displacement

# General information

## Degrees of protection & Insulation

Classification of degrees of protection provided by enclosures of rotating machines are refers to:

- Standard IS/IEC 60034-5 for IP code

### IP protection

Protection of persons against getting in contact with (or approaching) live parts and against contact with moving parts inside the enclosure. Also protection of the machine against ingress of solid foreign objects. Protection of machines against the harmful effects due to the ingress of water.

#### Explanation of the IP code

Ingress protection	Degree of protection to persons and to parts of the motors inside the enclosure	Degree of protection provided by the enclosure with respect to harmful effects due to ingress of water
IP	5	5
	1	2

#### Position 1

2:	Motors protected against solid objects greater than 12 mm
4:	Motors protected against solid objects greater than 1 mm
5:	Dust-protected motors
6:	Dust-tight motors

#### Position 2

3:	Motors protected against spraying water
4:	Motors protected against splashing water
5:	Motors protected against water jets
6:	Motors protected against heavy seas

ABB uses class F insulation, which, with temperature rise B, is the most common requirement among industry today.

The use of class F insulation with class B temperature rise gives ABB products a 25 °C safety margin. This can be used to increase the loading for limited periods, to operate at higher ambient temperatures or altitudes, or with greater voltage and frequency tolerances. It can also be used to extend insulation. For instance, a 10 K temperature reduction will extend the insulation life.

### Thermal class 130 (B)

- Nominal ambient temperature 50 °C
- Max permissible temperature rise 70 K
- Hot spot temperature margin 10 K

### Thermal class 155 (F)

- Nominal ambient temperature 50 °C
- Max permissible temperature rise 95 K
- Hot spot temperature margin 10 K

### Thermal class 180 (H)

- Nominal ambient temperature 50 °C
- Max permissible temperature rise 120 K
- Hot spot temperature margin 10 K

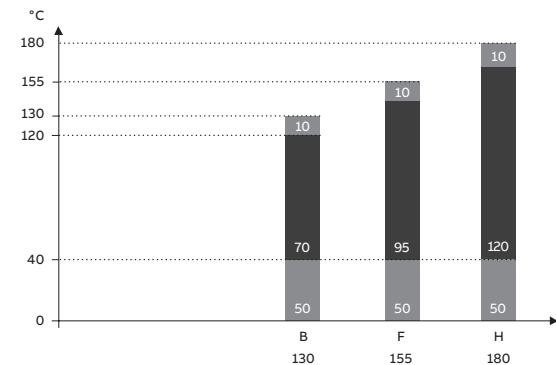

# General information

## Voltage and frequency

—  
01 Voltage and frequency  
deviation in zones A  
and B

The impact on temperature rise caused by voltage and frequency fluctuation is defined in IEC 60034-1. The standard divides the combinations into two zones, A and B. Zone A is the combination of voltage deviation of  $\pm 5\%$  and frequency deviation of  $\pm 2\%$ . Zone B is the combination of voltage deviation of  $\pm 10\%$  and frequency deviation of  $\pm 3\%$ . This is illustrated in figure below.

Motors are capable of supplying the rated torque in both zones A and B, but the temperature rise will be higher than at rated voltage and frequency. Motors can be run in zone B only for a short period of time.

### Key

X axis	frequency p.u.
Y axis	voltage p.u.
1	zone A
2	zone B (outside zone A)
3	rating point

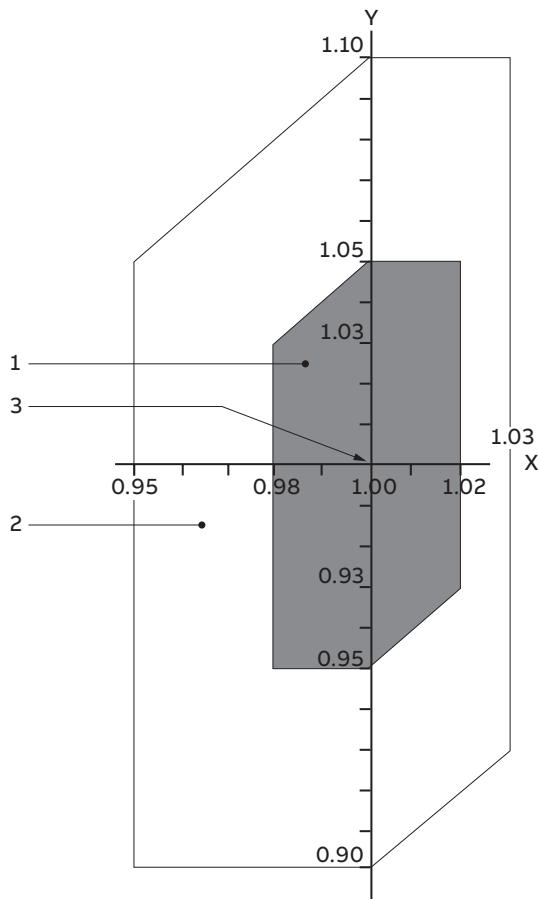

—  
01

## Technical data

### IE4 cast iron 415V, 50Hz motors, 3000, 1500 & 1000 r/min

IP 55 - IC 411 - Insulation class F, temperature rise class B  
IE4 efficiency class according to IEC 60034-30-1:2014, IS 12615:2018

Output KW	Frame Size	Speed r/min	Efficiency			Power factor cos $\phi$	Current		Torque			Moment of inertia $J=1/4GD^2$ kgm <sup>2</sup>	Weight kg
			Full load 100%	3/4 load 75%	1/2 load 50%		$I_n$ , A	$I_s/I_n$	$T_n$ Nm	$T_s/T_n$	$T_b/T_n$		
		415V, 50Hz											
3000 r/min													
0.37	M2BAX71MA2	2820	78.1	79.2	78.7	0.85	0.92	5	1.27	2.1	2.5	0.00035	9
0.55	M2BAX71MB2	2835	81.5	83	81.9	0.86	1.30	5	1.88	2.3	2.9	0.00047	10
0.75	M2BAX80MA2	2880	83.5	83.9	82.9	0.86	1.74	6.5	2.49	2.6	2.8	0.00117	15
1.1	M2BAX80MB2	2875	85.2	86.3	85.8	0.86	2.50	7	3.62	2.8	3.5	0.00145	17
1.5	M2BAX90SLA2	2880	86.5	87.1	86.2	0.86	3.20	7	4.97	2.9	3.5	0.00253	25
2.2	M2BAX90SLB2	2880	88	89.1	88.6	0.88	4.20	7.2	7.27	2.9	3.5	0.00346	30
3.7	M2BAX100LA2	2900	89.7	90.5	89.9	0.88	7.30	7.7	12.18	2.9	3.6	0.00606	41
5.5	M2BAX132SA2	2940	90.9	90.9	89.6	0.84	10.90	7	18.11	2.6	3.5	0.0197	66
7.5	M2BAX132SB2	2945	91.7	92.1	91.3	0.87	14.40	7.6	24.7	2.8	3.5	0.0248	73
9.3	M2BAX160MLJ2	2938	92.2	92.3	91.4	0.87	16.20	7.70	30.2	2.0	3.1	0.044	120
11	M2BAX160MLA2	2945	92.6	92.6	91.8	0.89	18.80	7.70	35.7	2.5	3.4	0.055	132
15	M2BAX160MLB2	2938	93.3	93.6	93.1	0.89	25.30	8.00	48.7	2.1	2.9	0.054	134
18.5	M2BAX160MLC2	2945	93.7	93.9	93.5	0.89	31.10	8.50	60.0	2.6	3.5	0.068	155
22	M2BAX180MLA2	2948	94.0	94.3	93.9	0.89	36.80	7.70	71.2	2.0	3.3	0.103	195
30	M2BAX200MLA2	2955	94.5	94.6	94.1	0.88	50.60	7.00	97.0	2.0	3.0	0.180	250
37	M2BAX200MLB2	2960	94.8	95.2	94.7	0.86	62.80	7.70	119.6	2.2	3.4	0.212	276
45	M2BAX225SMA2	2960	95.0	95.2	94.5	0.88	75.00	7.50	145.2	2.7	3.0	0.342	368
55	M2BAX250SMA2	2961	95.3	95.4	94.8	0.88	91.50	7.00	177.4	1.9	3.0	0.647	472

Output KW	Frame Size	Speed r/min	Efficiency			Power factor cos $\phi$	Current		Torque			Moment of inertia $J=1/4GD^2$ kgm <sup>2</sup>	Weight kg
			Full load 100%	3/4 load 75%	1/2 load 50%		$I_n$ , A	$I_s/I_n$	$T_n$ Nm	$T_s/T_n$	$T_b/T_n$		
		415V, 50Hz											
1500 r/min													
0.25	M2BAX71MA4	1440	77.9	77.7	75	0.75	0.66	5.5	1.65	2.4	3.3	0.00112	10
0.37	M2BAX71MLA4	1430	81.1	83.5	81.2	0.81	0.93	4.5	2.44	2.4	2.9	0.00153	13
0.55	M2BAX80MA4	1460	83.9	84.1	82.1	0.78	1.29	6.7	3.6	2.5	3	0.0024	17
0.75	M2BAX80MLA4	1455	85.7	85.6	83.8	0.76	1.90	6.5	4.92	2.5	3.5	0.00308	20
1.1	M2BAX90SLA4	1450	87.2	87.6	86.2	0.78	2.60	6.5	7.24	2.8	3.5	0.00526	27
1.5	M2BAX90SLB4	1455	88.2	88.5	86.9	0.77	3.56	6.8	9.88	2.8	3.5	0.00628	30
2.2	M2BAX100LA4	1455	89.5	90.3	89.7	0.8	4.80	6.7	14.34	2.4	3.1	0.012	41
3.7	M2BAX112MLA4	1460	90.9	91.4	90.6	0.79	8.10	6.5	24.1	2.4	3.5	0.0221	59
5.5	M2BAX132SA4	1475	91.9	92	91	0.79	11.70	8	35.61	2.8	3.5	0.0434	74
7.5	M2BAX132SMA4	1465	92.6	93.2	92.6	0.83	15.20	6.5	48.69	2.5	3.1	0.0573	93
9.3	M2BAX160MLJ4	1475	93.0	93.1	92.2	0.78	18.00	8.00	60.2	2.5	3.2	0.088	131
11	M2BAX160MLA4	1475	93.3	93.3	92.4	0.78	21.10	8.00	71.2	2.7	3.4	0.094	138
15	M2BAX160MLB4	1475	93.9	94.0	93.1	0.78	29.00	7.50	97.1	2.6	2.9	0.121	170
18.5	M2BAX180MLA4	1478	94.2	94.4	94.0	0.80	34.20	7.50	120.0	2.6	2.8	0.228	222
22	M2BAX180MLB4	1478	94.5	94.8	94.5	0.81	40.40	7.50	142.2	2.6	2.9	0.240	232
30	M2BAX200MLA4	1478	94.9	95.0	94.8	0.82	53.80	7.80	194.0	2.5	2.8	0.428	322
37	M2BAX225SMA4	1478	95.2	95.5	95.3	0.82	66.10	8.00	239.0	2.8	3.4	0.547	373
45	M2BAX225SMB4	1480	95.4	95.6	95.3	0.82	80.00	8.00	290.4	2.7	3.4	0.547	377
55	M2BAX250SMA4	1480	95.7	95.7	95.3	0.83	97.20	7.50	355.0	2.4	3.1	0.910	443

Note : All performance figures are subject to IS tolerances

$I_s / I_n$  = Starting current  
 $T_s / T_n$  = Locked rotor torque  
 $T_b / T_n$  = Breakdown

## Technical data

### IE4 cast iron 415V, 50Hz motors, 3000, 1500 & 1000 r/min

IP 55 - IC 411 - Insulation class F, temperature rise class B  
IE4 efficiency class according to IEC 60034-30-1:2014, IS 12615:2018

Output KW	Frame Size	Speed r/min	Efficiency			Power factor cos $\phi$	Current		Torque			Moment of inertia $J=1/4GD^2$ kgm <sup>2</sup>	Weight kg
			Full load 100%	3/4 load 75%	1/2 load 50%		$I_n$ , A	$I_s/I_n$	$T_n$ Nm	$T_s/T_n$	$T_b/T_n$		
1000 r/min		415V, 50Hz											
0.18	M2BAX71MA6	920	70.1	71	68.8	0.70	0.65	3.5	1.86	2.1	2.3	0.00103	10
0.25	M2BAX71MLA6	935	74.1	73.8	70.4	0.71	0.81	3.9	2.54	2.5	2.9	0.0014	12
0.37	M2BAX80MA6	945	78	78.6	76.3	0.7	1.20	3.9	3.72	1.9	2.5	0.00226	16
0.55	M2BAX80MLA6	950	80.9	81.9	80.7	0.74	1.46	3.8	5.52	1.9	2.1	0.00322	20
0.75	M2BAX90SLA6	950	82.7	83.9	83.2	0.75	1.90	4.6	7.54	1.7	2.6	0.0043	25
1.1	M2BAX90SLB6	960	84.5	84.8	83.2	0.7	2.90	5.2	11.06	2.1	2.9	0.00612	29
1.5	M2BAX100LA6	975	85.9	85.4	82.8	0.7	3.90	6.7	14.75	2.6	3.5	0.0138	43
2.2	M2BAX112MA6	965	87.4	87.6	86.2	0.71	5.60	5.4	21.55	2	2.9	0.0161	47
3.7	M2BAX132SA6	980	89.3	89.4	87.3	0.67	8.80	5.4	36.02	2.1	2.6	0.0436	74
5.5	M2BAX132SMA6	980	90.5	90.8	89.5	0.7	12.80	6.3	53.49	2.2	2.7	0.057	94
7.5	M2BAX160MLA6	975	91.3	91.4	90.4	0.74	15.70	7.00	73.5	1.9	2.7	0.109	144
9.3	M2BAX160MLJ6	976	91.9	92.1	91.2	0.74	19.00	7.00	91.0	1.9	2.8	0.118	147
11	M2BAX160MLB6	976	92.3	92.4	91.6	0.74	23.00	7.00	107.7	2.1	2.8	0.304	172
15	M2BAX180MLA6	977	92.9	93.3	92.8	0.75	30.50	7.00	146.6	1.9	2.8	0.207	195
18.5	M2BAX200MLA6	985	93.4	93.5	92.8	0.77	35.70	7.80	179.4	2.4	3.0	0.397	227
22	M2BAX200MLB6	986	93.7	93.8	93.2	0.78	42.30	8.00	213.1	2.4	3.1	0.490	269
30	M2BAX225SMA6	986	94.2	94.4	94.0	0.79	56.00	7.50	290.6	2.6	3.0	0.807	350
37	M2BAX250SMA6	983	94.5	94.7	94.1	0.79	70.80	7.50	359.0	2.6	3.2	1.680	467

Note : All performance figures are subject to IS tolerances

Efficiency values are given according to IEC 60034-30-1: 2014.  
Please note that the values are not comparable without knowing the testing method.

ABB has calculated the efficiency values according to indirect method, stray load losses (additional losses) determined from measuring.

$I_s / I_n$  = Starting current  
 $T_s / T_n$  = Locked rotor torque  
 $T_b / T_n$  = Breakdown

## Technical data

Process performance IE4 efficiency cast iron motors

415V, 50Hz motors, 3000, 1500 & 1000 r/min

IIP55 - IC 411 - Insulation class F, Ambient 50°C (Temp. rise class B, 70°C), S1 Duty

IE4 efficiency class according to IS 12615:2018, IEC 60034-30-1, 2014, 415V ± 10%, 50 ± 5% Hz, Combined Variation of ± 10%

Output KW	Motor type	Product code	Speed r/min	Efficiency			Power factor			Current		Torque (Nm)			Moment of inertia J=1/4GD <sup>2</sup> kgm <sup>2</sup>	Weight kg	Sound pressure level LPA (dB)
				FL 100%	FL 75%	FL 50%	100%	75%	50%	I <sub>n</sub> , A	I <sub>s</sub> /I <sub>n</sub>	T <sub>n</sub>	T <sub>s</sub> /T <sub>n</sub>	T <sub>max</sub> /T <sub>n</sub>			
2 Pole, 3000 r/min																	
75	M3BP 280SMB 2	3GBP281220-ADM	2981	95.6	95.6	94.6	0.86	0.81	0.73	127	8.9	240	2.6	3.1	0.9	665	90
90	M3BP 280SMC 2	3GBP281230-ADM	2982	95.8	95.8	94.8	0.87	0.83	0.75	150	8.9	288	2.8	3.3	1.2	725	90
110	M3BP 315SMB 2	3GBP311220-ADM	2984	96.0	96.0	95.0	0.86	0.82	0.75	185	8.9	352	2.0	2.8	1.4	940	90
132	M3BP 315SMC 2	3GBP311230-ADM	2985	96.2	96.2	95.2	0.87	0.81	0.75	220	8.9	422	2.6	3.0	1.7	1025	90
160	M3BP 315MLA 2	3GBP311410-ADM	2985	96.3	96.3	95.3	0.88	0.83	0.78	263	8.9	512	2.4	2.9	2.1	1190	90
200	M3BP 315MLB 2	3GBP311420-ADM	2985	96.5	96.5	95.5	0.87	0.85	0.80	332	8.9	640	2.4	2.9	2.2	1220	90
200	M3BP 355SMA 2	3GBP351210-ADM	2985	96.5	96.5	95.5	0.87	0.85	0.80	332	8.9	640	2.4	3.3	3.0	1600	90
250	M3BP 315LKB 2	3GBP311820-ADM	2985	96.5	96.5	95.5	0.87	0.84	0.80	414	8.9	800	2.6	2.9	2.9	1540	90
250	M3BP 355SMB 2	3GBP351220-ADM	2985	96.5	96.5	95.5	0.87	0.84	0.80	414	8.9	800	2.5	3.2	3.4	1680	90
315	M3BP 355SMC 2	3GBP351230-ADM	2985	96.5	96.5	95.5	0.86	0.82	0.76	528	8.9	1008	2.5	3.0	3.6	1750	90
355	M3BP 355MLA 2	3GBP351410-ADM	2985	96.5	96.5	95.5	0.87	0.84	0.79	589	8.9	1136	2.5	2.8	4.1	2000	90
4 Pole, 1500 r/min																	
75	M3BP 280SMC 4	3GBP282230-ADM	1488	96.0	96.0	95.0	0.83	0.78	0.65	131	8.9	481	2.8	3.0	1.85	725	85
90	M3BP 280MLA 4	3GBP282410-ADM	1489	96.1	96.1	95.1	0.82	0.80	0.70	157	8.9	577	2.8	3.2	2.3	840	85
110	M3BP 315SMC 4	3GBP312230-ADM	1491	96.3	96.3	95.3	0.82	0.75	0.68	194	8.9	704	2.6	3.1	2.9	1000	85
132	M3BP 315SMD 4	3GBP312240-ADM	1491	96.4	96.4	95.4	0.82	0.75	0.65	233	8.9	845	2.7	3.4	3.2	1065	85
160	M3BP 315MLB 4	3GBP312420-ADM	1490	96.6	96.6	95.6	0.84	0.80	0.70	274	8.9	1025	2.9	3.1	3.9	1220	85
200	M3BP 315LKB 4	3GBP312820-ADM	1491	96.7	96.7	95.7	0.84	0.79	0.70	343	8.9	1281	2.7	3.1	5.0	1520	85
200	M3BP 355SMA 4	3GBP352210-ADM	1491	96.7	96.7	95.7	0.84	0.79	0.70	343	8.9	1281	2.3	2.9	5.9	1610	85
250	M3BP 315LKC 4	3GBP312830-ADM	1491	96.7	96.7	95.7	0.83	0.80	0.70	434	8.9	1601	2.5	3.2	5.5	1600	85
250	M3BP 355SMB 4	3GBP352220-ADM	1492	96.7	96.7	95.7	0.83	0.80	0.70	434	8.9	1600	2.7	3.1	6.9	1780	85
315	M3BP 355SMC 4	3GBP352230-ADM	1492	96.7	96.7	95.7	0.83	0.78	0.69	546	8.9	2016	2.9	3.1	7.2	1820	85
355	M3BP 355MLA 4	3GBP352410-ADM	1492	96.7	96.7	95.7	0.83	0.79	0.70	615	8.9	2272	2.9	3.1	8.4	2140	85
6 Pole, 1000 r/min																	
45	M3BP 280SMB 6	3GBP283220-ADM	991	94.8	94.8	92.8	0.83	0.78	0.68	80	8.3	434	2.5	2.8	2.2	680	85
55	M3BP 280SMC 6	3GBP283230-ADM	991	95.1	95.1	93.1	0.83	0.77	0.70	97	8.3	530	2.6	2.8	2.9	725	85
75	M3BP 315SMC 6	3GBP313230-ADM	994	95.4	95.4	93.4	0.80	0.75	0.68	137	8.9	720	2.4	3.0	4.9	1000	85
90	M3BP 315SMD 6	3GBP313240-ADM	994	95.6	95.6	93.6	0.78	0.72	0.61	168	8.9	865	2.6	3.0	4.9	1040	85
110	M3BP 315MLB 6	3GBP313420-ADM	994	95.8	95.8	93.8	0.80	0.75	0.65	200	8.9	1057	2.5	2.9	6.3	1200	85
132	M3BP 315LKA 6	3GBP313810-ADM	994	96.0	96.0	94.0	0.80	0.75	0.64	239	8.9	1268	2.6	2.9	7.3	1410	85
160	M3BP 315LKC 6	3GBP313830-ADM	994	96.2	96.2	94.2	0.80	0.73	0.62	289	8.9	1537	2.7	3.0	9.2	1600	85
160	M3BP 355SMB 6	3GBP353220-ADM	995	96.2	96.2	94.2	0.80	0.75	0.63	289	8.9	1536	2.2	2.9	9.7	1680	85
200	M3BP 355SMC 6	3GBP353230-ADM	995	96.6	96.6	94.6	0.81	0.75	0.64	356	8.9	1919	2.5	3.0	11.3	1820	85
250	M3BP 355MLB 6	3GBP353420-ADM	995	96.6	96.6	94.6	0.80	0.75	0.65	450	8.9	2399	2.5	2.9	13.5	2180	85
315	M3BP 355LKA 6	3GBP353810-ADM	995	96.6	96.6	94.6	0.80	0.75	0.65	567	8.9	3023	2.5	2.8	15.5	2500	85
355	M3BP 355LKB 6	3GBP353820-ADM	995	96.6	96.6	94.6	0.78	0.70	0.60	655	8.9	3407	2.7	3.0	16.5	2600	85

Note: 1. All performance figures are subject to IEC/IS tolerances.  
 2. Max. load GD<sup>2</sup> has been calculated assuming load torque is proportional to square of speed.  
 3. Higher kw can be offered on demand

I<sub>n</sub> = Nominal or rated current  
 T<sub>n</sub> = Nominal or rated torque in Nm  
 T<sub>max</sub> = Maximum torque  
 I<sub>s</sub> = Starting current  
 T<sub>s</sub> = Starting Torque

## Dimension drawings

Super Premium Cast iron IE4 energy efficient motors

Foot-mounted motor IM1001, B3 and Flange-mounted motor IM 3001, B5

Size 71 to 132

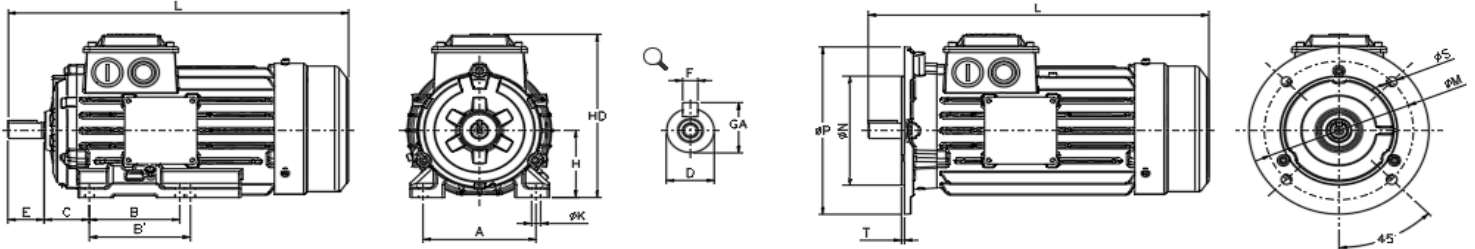

Size 160 to 250

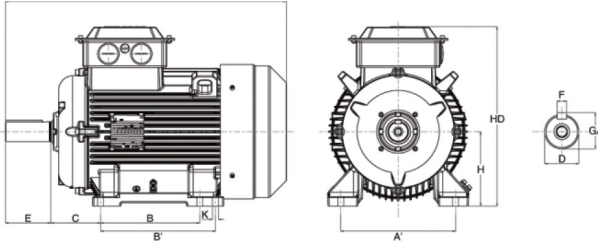

Size 160 to 200

Size 225 to 250

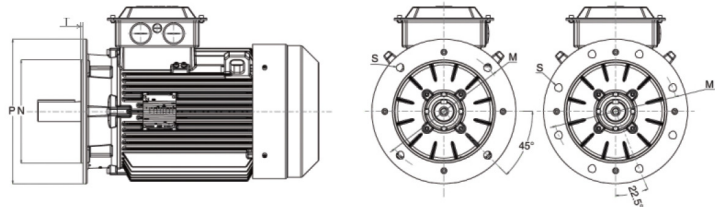

Motor Size	D Pole		GA Pole		F Pole		E Pole		Lmax Pole		A	B	B'	C	HD	K	H	M	N	P	S	T
	2	4-6	2	4-6	2	4-6	2	4-6	2	4-6												
General performance cast iron motors																						
71	14	14	16	16	5	5	30	30	272	272	112	90	-	45	175	7	71	130	110	160	10	3.5
71									322	322		90	-									
80	19	19	21.5	21.5	6	6	40	40	327	327	125	100	-	50	191	10	80	165	130	200	12	3.5
80ML									377	377	125	100	112									
90SL	24	24	27	27	8	8	50	50	405	405	140	100	125	56	217	10	90	165	130	200	12	3.5
90L									430	430	140	-	125									
100L	28	28	31	31	8	8	60	60	464	464	160	112	-	63	242	12	100	215	180	250	15	4
100LK									504	504	160	112	140									
112M	28	28	31	31	8	8	60	60	415	415	190	140	-	70	263	12	112	215	180	250	15	4
112ML									480	480	190	140	159									
132S	38	38	41	41	10	10	80	80	515	515	216	140	-	89	307	12	132	265	230	300	15	4
132SM									610	610	216	140	178									
160ML	42	42	45	45	12	12	110	110	696 <sup>1</sup>	696 <sup>1</sup>	254	210	254	108	414	15	160	300	250	350	19	5
180ML	48	48	51.5	51.5	14	14	110	110	798	798	279	241	279	121	454	15	180	300	250	350	19	5
200ML	55	55	59	59	16	16	110	110	809 <sup>2</sup>	809 <sup>2</sup>	318	267	305	113	515	19	200	350	300	400	19	5
225SM	55	60	59	64	16	18	110	140	942	972	356	286	311	149	560	19	225	400	350	450	19	5
250SM	60	65	64	69	18	18	140	140	913	913	406	311	349	168	613	24	250	500	450	550	19	5

Above table gives the main dimensions in mm.

- 1) M2BAX 160ML C2, B4, B6: L = 746
- 2) M2BAX 200ML B2, A4, B6 = 899

## Dimension drawings

Process performance IE4 efficiency cast iron motors

Foot-mounted motor IM1001, B3 and Flange-mounted motor IM 3001, B5

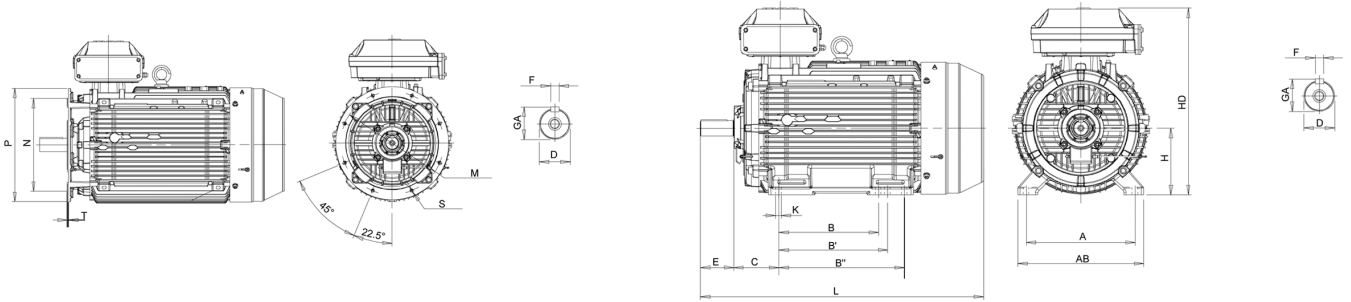

Motor Size	D Poles		GA Poles		F Poles		E Poles		L max Poles		A	B	B'	B''	C	HD	K	H	M	N	P	S	T
	2	4-6	2	4-6	2	4-6	2	4-6	2	4-6													

### Process performance cast iron motors

280	65	75	69	79.5	18	20	140	140	1088	1088	457	368	419	-	190	762	24	280	500	450	550	19	5
280ML	65	75	69	79.5	18	20	140	140	1189	1189	457	419	457	-	190	785	24	280	500	450	550	19	5
315SM	65	80	69	85	18	22	140	170	1174	1204	508	406	457	-	216	852	28	315	600	550	660	24	6
315ML	65	90	69	95	18	25	140	170	1285	1315	508	457	508	-	216	852	28	315	600	550	660	24	6
315LK	65	90	69	95	18	25	140	170	1491	1521	508	508	560	710	216	880	28	315	600	550	660	24	6
355SM	70	100	74.5	106	20	28	140	210	1409	1479	610	500	560	-	254	958	35	355	740	680	800	24	6
355ML	70	100	74.5	106	20	28	140	210	1514	1584	610	560	630	-	254	958	35	355	740	680	800	24	6
355LK	70	100	74.5	106	20	28	140	210	1764	1834	610	630	710	900	254	958	35	355	740	680	800	24	6

Above table gives the main dimensions in mm.

## Motors in brief

Super Premium Cast iron IE4 energy efficient motors 71-132

Size		71	80	90	100	112	132
<b>Stator</b>	Material	Cast Iron Grade 150:ISO 185					
	Paint colour shade	Munsell blue 8B 4.5/3.25 / NCS 4822 B05G					
	Surface Treatment	C3 medium according to ISO / EN 12944-5					
<b>Feet</b>		Integrated with stator					
	Material	Cast iron grade 150 : ISO 185					
<b>Bearing end shields</b>	Material	Cast iron grade 200 : ISO 185					
	Paint colour shade	Munsell blue 8B 4.5/3.25/NCS 4822 B05G					
	Surface Treatment	C3 medium according to ISO / EN 12944-5					
<b>Bearings</b>	D-end	6203-2Z/C3	6204-2Z/C3	6205-2Z/C3	6206-2Z/C3	6207-2Z/C3	6208-2Z/C3
	N-end	6202-2Z/C3	6204-2Z/C3	6205-2Z/C3	6206-2Z/C3	6206-2Z/C3	6208-2Z/C3
<b>Axially-locked</b>	Retaining Ring	As standard, locked at D-end					
<b>Bearing seals</b>		Axial seal as standard, radial on request					
<b>Lubrication</b>		Permanently lubricated shielded bearings					
<b>Rating plate</b>	Material	Aluminium					
<b>Terminal Box</b>	Frame material	Cast Iron, Integral to stator frame					
	Cover material	Sheet of steel, Cold rolled					
	Cover screws material	Steel 8.8					
<b>Connections</b>	Cable entries	2xM16	2xM25	2xM32			
	Cable Sizes	2Rx3Cx4mm <sup>2</sup>	2Rx3Cx6mm <sup>2</sup>	2Rx3Cx10mm <sup>2</sup>			
	Terminal Stud Size	M4	M4	M5			
	Terminals	Upto 2HP- STAR / 3 Leads > 2 HP- DELTA / 6 Leads (Cable lugs not included)					
<b>Fan</b>	Material	Polypropylene, Reinforced with 20% glass fibre					
<b>Fan Cover</b>	Material	Sheet of steel, cold rolled					
	Paint Colour shade	Munsell blue 8B 4.5/3.25/NCS 4822 B05G					
	Surface Treatment	C3 medium according to ISO/EN 12944-5					
<b>Stator winding</b>	Material	Copper					
	Insulation	Insulation class F, Temperature rise class B unless otherwise stated					
	Winding protection	3PTC thermistors as a option					
<b>Rotor winding</b>	Material	Pressure diecast aluminum					
<b>Balancing method</b>		Half Key Balancing as Standard					
<b>Key way</b>		Open Key Way					
<b>Enclosure</b>		IP 55, Higher protection on request					
<b>Cooling method</b>		IC 411					
<b>Drain holes</b>		Drain holes with closable plastic plugs, open on delivery					
<b>Lifting lugs</b>		Integrated with the stator					

## Motors in brief

Super Premium Cast iron IE4 energy efficient motors 160 - 250

Output		160	180	200	225	250
<b>Stator</b>	Material	Cast Iron Grade 200:ISO 185				
	Paint colour shade	Munsell blue 8B 4.5/3.25 / NCS 4822 B05G				
	Surface Treatment	C3 medium according to ISO / EN 12944-5				
<b>Bearing end shields</b>	Material	Cast iron grade 200 : ISO 185				
	Paint colour shade	Munsell blue 8B 4.5/3.25/NCS 4822 B05G				
	Surface Treatment	C3 medium according to ISO / EN 12944-5				
<b>Bearings</b>	D-end	6309-2Z/C3	6310-2Z/C3	6312-2Z/C3	6313-2Z/C3	6315-2Z/C3
	N-end	6209-2Z/C3	6209-2Z/C3	6209-2Z/C3	6210-2Z/C3	6212-2Z/C3
<b>Axially-locked</b>	Inner Bearing Cover	<b>As standard, locked at D-end</b>				
<b>Bearing seals</b>		Axial seal standard, radial on request				
<b>Lubrication</b>		Permanently lubricated shielded bearings				
<b>Measuring nipple</b>		Not included				
<b>Rating plate</b>	Material	Aluminium				
<b>Terminal Box</b>	Frame material	Sheet of Steel, cold rolled				
	Cover material	Sheet of Steel, cold rolled				
	Cover screws material	Steel 8.8				
<b>Connections</b>	Cable entries	2xM40, 1xM16		2xM50, 1xM16		
	Terminals	6 terminals of connection (Cable lugs not included)				
	Cable gland	Suitable opening in terminal box, cable glands as option				
<b>Fan</b>	Material	Polypropylene, Reinforced with 20% glass fibre				
<b>Fan Cover</b>	Material	Sheet of steel, cold rolled				
	Paint Colour shade	Munsell blue 8B 4.5/3.25/NCS 4822 B05G				
	Surface Treatment	C3 medium according to ISO/EN 12944-5				
<b>Stator winding</b>	Material	Copper				
	Insulation	Insulation class F, Temperature rise class B unless otherwise stated.				
	Winding protection	<b>3 PTC thermistors as option</b>				
<b>Rotor winding</b>	Material	Pressure diecast aluminium				
<b>Balancing method</b>		Half Key Balancing as Standard				
<b>Key way</b>		Open Key Way				
<b>Enclosure</b>		IP 55, Higher protection on request				
<b>Cooling method</b>		IC 411				

## Motors in brief

Process performance IE4 efficiency cast iron motors  
sizes 280 - 355

Output		280	315	355	
<b>Stator and end shields</b>	Material	Cast Iron			
	Paint colour shade	Munsell blue 8B 4.5/3.25			
	Corrosion class	C3 (medium)			
<b>Feet</b>	Material	Integrated cast iron feet			
<b>Bearings</b>	D-end	2-pole	6316/C3	6316/C3	6316M/C3
		4-12-pole	6316/C3	6319/C3	6322/C3
	N-end	2-pole	6316/C3	6316/C3	6316M/C3
		4-12-pole	6316/C3	6316/C3	6316/C3
<b>Axially-locked bearings</b>		Locked at D-end			
<b>Bearing seals</b>	D-end	V-ring or labyrinth seal			
	N-end	V-ring or labyrinth seal			
<b>Lubrication</b>		Regreaseable bearings, regreasing nipples M10x1			
<b>Measuring nipple for condition monitoring of the bearings</b>		Included			
<b>Rating plate</b>	Material	Stainless steel			
<b>Terminal box</b>	Frame and cover	Cast iron		Cover steel	
	Corrosion class	C3 (medium)		Steel	
	Cover screws	Zinc-electroplated steel			
<b>Connections</b>	Cable entries	2-4-pole	2xM63+2xM20	2xM63, 2xØ48-60+2xM20	2xØ48-60, 60-80, 2xM20
		6-8-pole			2xØ32-49, 48-60, 2M20
	See section Standard terminal box for detailed information.				
	Terminals	6 terminals of connection (Cable lugs not included)			
	Cable gland	Suitable opening in terminal box, cable glands as option			
<b>Fan</b>	Material	Glass-fiber reinforced polypropylene			
<b>Fan Cover</b>	Material	Sheet			
	Paint Colour shade	Munsell blue 8B 4.5/3.25			
	Corrosion class	C3 (medium)			
<b>Stator winding</b>	Material	Copper			
	Insulation	Insulation class F, Temperature rise class B unless otherwise stated.			
	Winding protection	3 PTC thermistors, 155 °C			
<b>Rotor winding</b>	Material	Pressure diecast aluminium			
<b>Balancing method</b>		Half key balancing			
<b>Key ways</b>		Open key way			
<b>Drain holes</b>		Drain holes with closable plastic plugs, open on delivery			
<b>Enclosure</b>		IP 55			
<b>Cooling method</b>		IC 411			

# Product note

## IE4 efficiency cast iron motors, sizes 71 - 450



ABB is the first Global motor manufacturer with Make in India initiative to launch entire range of low voltage IE4 range based on induction technology. The motors cover 0.18 - 1000 kW . frame sizes 71 - 450. They are available for 415 V, 50 Hz and 440/460 V, 60 Hz in 2-, 4- and 6-pole versions.

IE4 motors meet the energy efficiency requirements defined in IEC Technical Specification IEC/TS 60034-31 and draft IEC standard 60034-30 edition 2.

### Platform

ABB's IE4 motors are based on the robust and well-proven induction platform. They have the same mechanical design as the other ABB high efficiency motors, and they meet IE4 requirements without using permanent magnets.

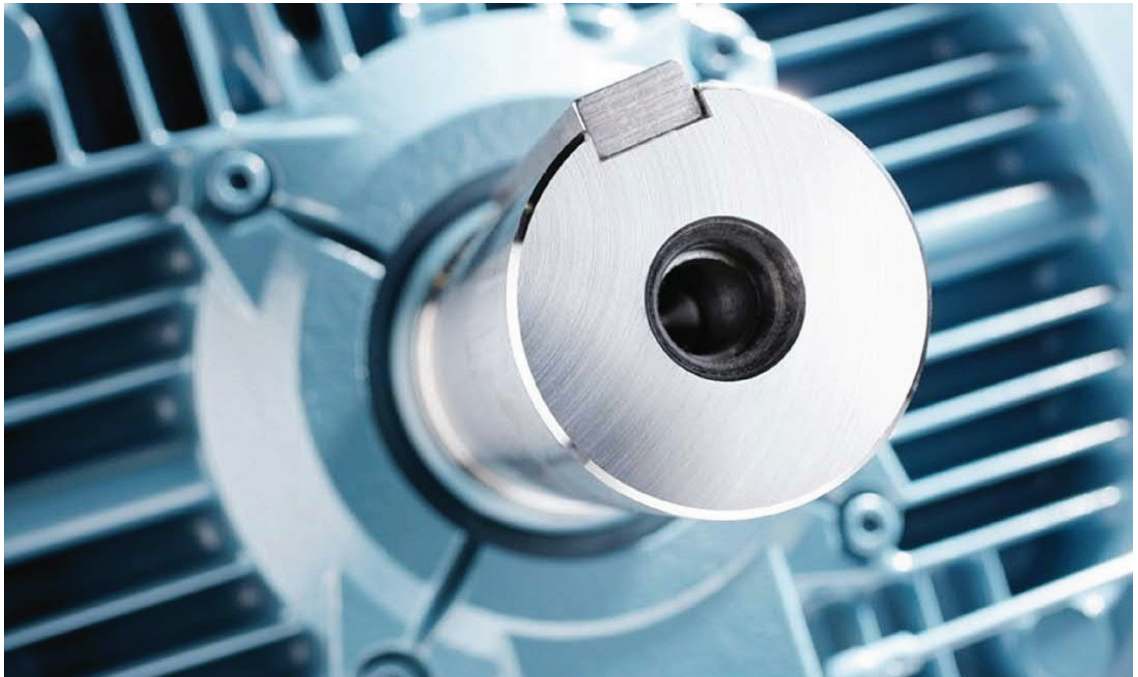
### Benefits

IE4 motors deliver the highest efficiency currently available in the market, enabling motor users to maximize energy

savings. As a result they are especially suited for applications with high operating hours.

By using an IE4 motor in place of a lower efficiency product it is possible to achieve a significant efficiency improvement, which will produce substantial energy savings over the motor's lifetime.

At the same time, the reduction in energy consumption means that overall carbon dioxide emissions are decreased – a factor which will help plants to meet their environmental commitments.

A further benefit of higher efficiency is cooler running, which means that these motors operate even more reliably than less efficient alternatives. The combination of high efficiency and reliability enables motor users to optimize the cost of motor ownership.

# ABB Ability™ Smart Sensor

## Condition monitoring solution for low voltage motors

ABB Ability™ Smart Sensor is a condition monitoring solution that makes predictive maintenance possible for almost all low voltage motors. By monitoring and analyzing data on motor operating parameters, it enables motor users to optimize their maintenance. The solution helps to reduce downtime by as much as 70 percent, extend motor lifetimes by up to 30 percent and reduce energy consumption by up to 10%.

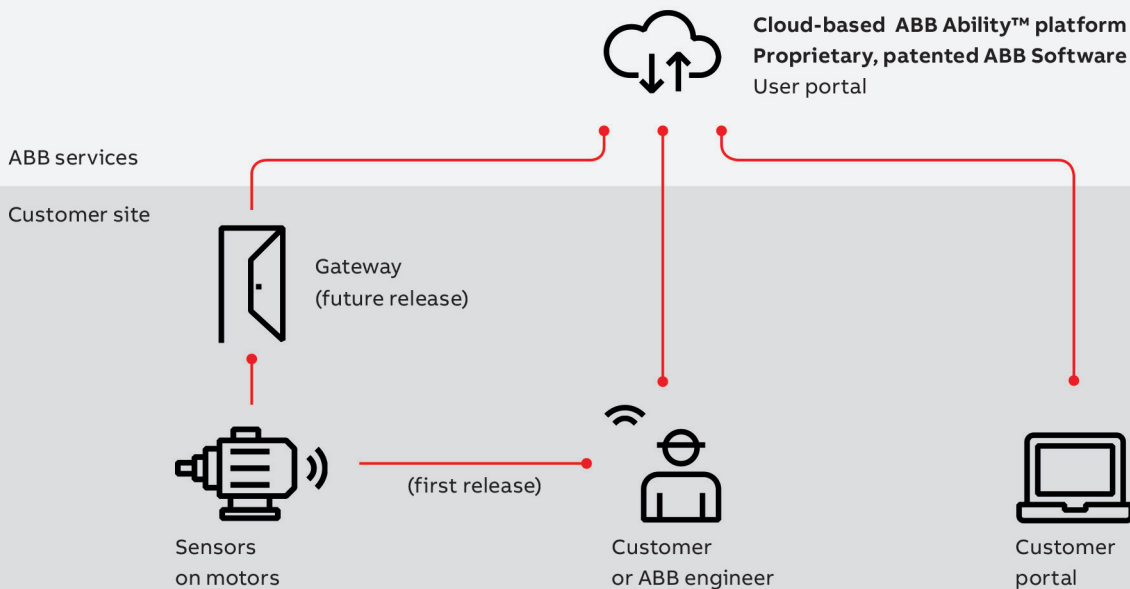
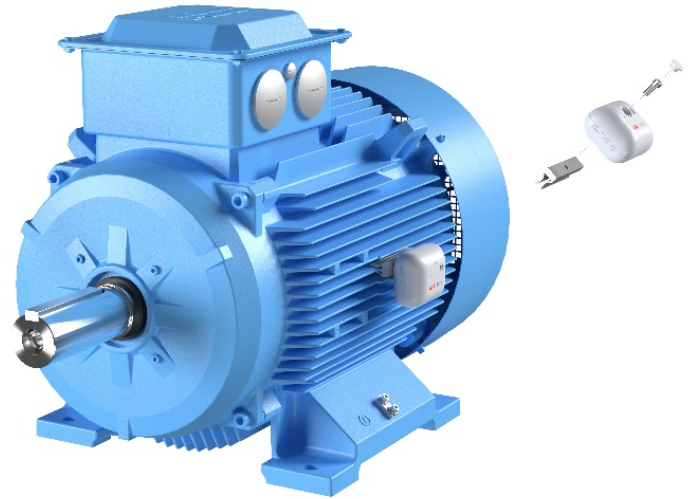

ABB's condition monitoring solution for LV motors. The ABB Ability™ Smart Sensor transmits data via a smartphone (first release) or gateway to a secure cloud service. Algorithms in the cloud analyze the data and convert it into meaningful information, which is then sent to the user's smartphone and customer portal.

For more information please visit:  
[www.abb.com/smartsensor](http://www.abb.com/smartsensor)  
 or contact [contact.center@in.abb.com](mailto:contact.center@in.abb.com)



—  
**ABB India Limited**  
32, Industrial Area,  
N.I.T., Faridabad - 121 001  
Tel: +91 129 2448100

**[www.abb.co.in](http://www.abb.co.in)**

We reserve the right to make technical changes or modify the contents of this document without prior notice. With regard to purchase orders, the agreed particulars shall prevail. ABB does not accept any responsibility whatsoever for potential errors or possible lack of information in this document.

We reserve all rights in this document and in the subject matter and illustrations contained therein. Any reproduction, disclosure to third parties or utilization of its content - in whole or in parts - is forbidden without ABB's prior written consent.



---

## **Low Voltage**

General Performance

High efficiency aluminum motors

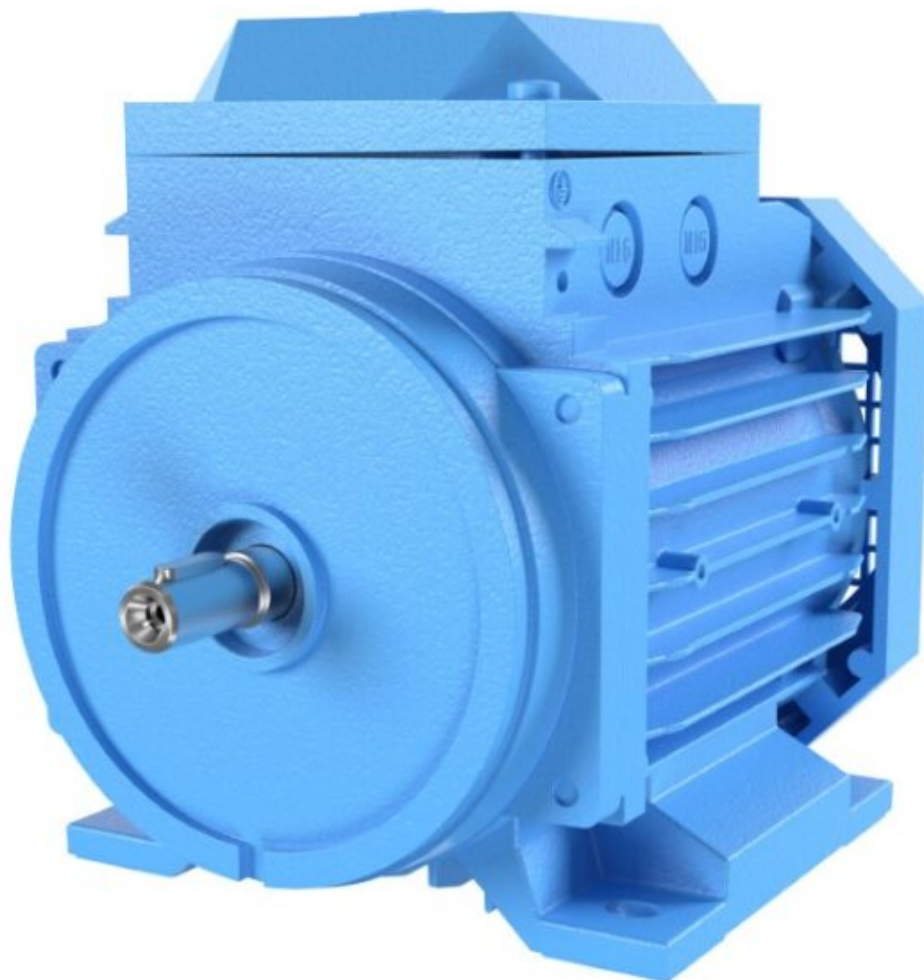

---

**ABB offers a comprehensive range of reliable and high efficiency motors. ABB's general performance IE2, IE3 efficiency motors are best suited for applications where simplicity and off-the-shelf availability are paramount.**

---

# General performance IE2, IE3 high efficiency aluminum motors Sizes 71 to 90

<b>04</b>	<b>Product Note</b>
<b>05 - 06</b>	<b>Technical data</b>
<b>07</b>	<b>Dimension drawings</b>
<b>08</b>	<b>General performance motors in brief</b>
<b>09</b>	<b>Application note</b>

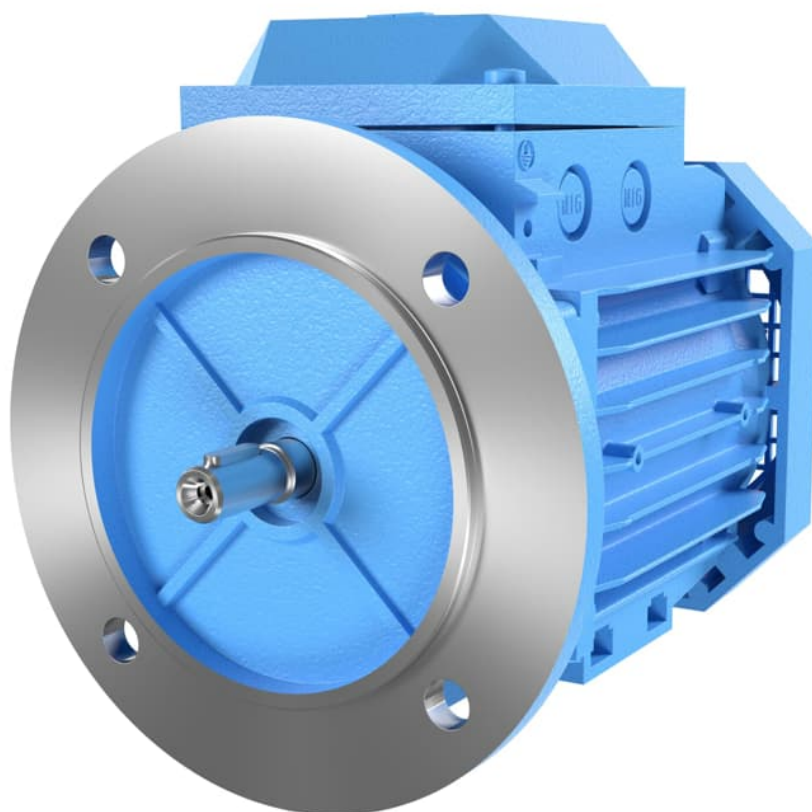

# IEC Low Voltage Aluminum Motors

## Flexible, light and corrosion resistant

ABB's 'made in India' Aluminum motors are optimally tailored for a range of applications, including machine tools, food & beverage, and HVAC systems. Crafted with precision, these motors are engineered to meet demands of applications with low weight and corrosion-resistant equipment. They stand for a seamless blend of energy efficiency and unwavering reliability, catering to the demands of diverse industries.

Available in IE2 & IE3 efficiency classes,  
71-90 framesize with output ranging from 0.18 - 2.2kW.

### Key Features



#### Reliable

Better heat dissipation, makes it more reliable for longer life



#### Better Finish

High pressure die-casted components (HPDC) for precise finish



#### Durable

Shot blasted aluminum components & C3 corrosion class painting system



#### Flexible

Due to low weight, used in machineries to add flexibility to the system



#### Circularity

Aluminum a highly sustainable 'green' metal, can be recycled after end of the life

## Technical data

IE2 high efficiency aluminum motors

Technical data for totally enclosed squirrel cage three phase induction motors

IP 55 - IC 411 - Insulation class F, temperature rise class B, IE2 efficiency class according to IEC 60034-30-1:2014, IS 12615:2018  
TEFC, 415V, 50Hz, IP55, IC411, Ambt. 50 deg, Rise Class B (70 deg)

Output KW	Frame Size	Speed r/min	Efficiency			Power factor cos $\phi$	Current		Torque			Moment of inertia $J=1/4GD^2$ kgm <sup>2</sup>	Weight kg
			Full load 100%	3/4 load 75%	1/2 load 50%		$I_n$ , A	$I_s/I_n$	$T_n$ Nm	$T_s/T_n$	$T_b/T_n$		
3000 r/min = 2 poles			415V, 50Hz										
0.37	M2AAX71MA2	2760	72.2	72.9	70.3	0.79	0.90	5.0	1.3	2.0	2.4	0.00033	5
0.55	M2AAX71MB2	2785	74.8	75.5	73.0	0.79	1.30	5.0	1.9	2.2	2.7	0.00041	6
0.75	M2AAX80MA2	2820	77.4	78.0	75.7	0.79	1.70	6.0	2.5	2.3	2.8	0.00067	9
1.1	M2AAX80MB2	2840	79.6	80.0	77.9	0.77	2.5	6.0	3.7	2.5	3.0	0.00088	10
1.5	M2AAX90SA2	2875	81.3	82.0	80.3	0.83	3.1	6.0	5.0	2.3	3.0	0.00208	13
2.2	M2AAX90LA2	2878	83.2	84.0	82.6	0.84	4.4	7.0	7.3	2.5	3.1	0.00274	16

Output KW	Frame Size	Speed r/min	Efficiency			Power factor cos $\phi$	Current		Torque			Moment of inertia $J=1/4GD^2$ kgm <sup>2</sup>	Weight kg
			Full load 100%	3/4 load 75%	1/2 load 50%		$I_n$ , A	$I_s/I_n$	$T_n$ Nm	$T_s/T_n$	$T_b/T_n$		
1500 r/min = 4 poles			415V, 50Hz										
0.25	M2AAX71MA4	1395	68.5	67.5	62.1	0.65	0.9	5.0	1.7	1.9	2.2	0.00059	5
0.37	M2AAX71MB4	1395	72.7	72.0	67.0	0.65	1.10	5.0	2.5	1.9	2.2	0.00076	6
0.55	M2AAX80MA4	1415	77.1	76.0	71.0	0.71	1.40	5.0	3.7	2.2	2.8	0.00156	8
0.75	M2AAX80MB4	1425	79.6	78.5	74.3	0.67	1.97	6.0	5.0	3.0	3.5	0.00247	12
1.1	M2AAX90SA4	1430	81.4	80.6	76.8	0.74	2.55	6.0	7.3	3.0	3.5	0.00372	14
1.5	M2AAX90LA4	1430	82.8	82.2	79.4	0.73	3.47	6.0	10.0	3.0	3.5	0.00462	16

Output KW	Frame Size	Speed r/min	Efficiency			Power factor cos $\phi$	Current		Torque			Moment of inertia $J=1/4GD^2$ kgm <sup>2</sup>	Weight kg
			Full load 100%	3/4 load 75%	1/2 load 50%		$I_n$ , A	$I_s/I_n$	$T_n$ Nm	$T_s/T_n$	$T_b/T_n$		
1000 r/min = 6 poles			415V, 50Hz										
0.18	M2AAX71MA6	900	56.6	54.6	47.6	0.62	0.64	3.5	1.9	2.0	2.1	0.00082	5
0.25	M2AAX71MB6	900	61.6	61.3	55.8	0.62	1.00	3.5	2.65	2.0	2.1	0.00105	6
0.37	M2AAX80MA6	910	69.0	68.1	63.1	0.62	1.20	4.0	3.9	2.0	2.4	0.00173	9
0.55	M2AAX80MB6	910	73.1	72.8	69.2	0.66	1.60	4.0	5.8	2.1	2.5	0.00274	10
0.75	M2AAX90SA6	945	75.9	74.3	69.2	0.62	2.2	4.5	7.6	2.4	3.2	0.00438	14
1.1	M2AAX90LA6	935	78.1	77.3	73.3	0.63	3.1	4.5	11.2	2.3	2.9	0.00507	17

Efficiency values are measured according to IEC 60034-2-1; 2007, IS 15999(Part2 Sec1):2011  
Please note that the values are not comparable without knowing the testing method. ABB has calculated the efficiency values according to indirect method, stray load losses (additional losses) determined from measuring.

$I_s / I_n$  = Starting current  
 $T_s / T_n$  = Locked rotor torque  
 $T_b / T_n$  = Breakdown

## Technical data

IE3 premium efficiency aluminum motors

Technical data for totally enclosed squirrel cage three phase induction motors

IP 55 - IC 411 - Insulation class F, temperature rise class B, IE3 efficiency class according to IEC 60034-30-1:2014, IS 12615:2018

TEFC, 415V, 50Hz, IP55, IC411, Ambt. 50 deg, Rise Class B (70 deg)

Output KW	Frame Size	Speed r/min	Efficiency			Power factor cos $\phi$	Current		Torque			Moment of inertia J=1/4GD <sup>2</sup> kgm <sup>2</sup>	Weight kg
			Full load 100%	3/4 load 75%	1/2 load 50%		I <sub>n</sub> , A	I <sub>s</sub> /I <sub>n</sub>	T <sub>n</sub> Nm	T <sub>s</sub> /T <sub>n</sub>	T <sub>b</sub> /T <sub>n</sub>		
		3000 r/min = 2 poles		415V, 50Hz									
0.37	M2AAX71MC2	2790	75.5	75.4	72.7	0.72	0.95	5.5	1.3	2.1	2.5	0.00033	5
0.55	M2AAX71MB2	2782	78.1	78.4	76.4	0.73	1.35	5.5	1.9	2.1	2.6	0.00041	6
0.75	M2AAX80MC2	2870	80.7	80.0	76.7	0.76	1.7	6.5	2.5	2.8	3.6	0.00080	9
1.1	M2AAX80MD2	2865	82.7	83.3	81.9	0.80	2.3	7.0	3.7	2.8	3.6	0.00119	11
1.5	M2AAX90SB2	2882	84.2	84.6	83.0	0.83	3	6.0	5.0	2.7	3.3	0.00224	15
2.2	M2AAX90LB2	2890	85.9	86.7	85.8	0.88	4.4	7.0	7.3	3.0	3.5	0.00304	18

Output KW	Frame Size	Speed r/min	Efficiency			Power factor cos $\phi$	Current		Torque			Moment of inertia J=1/4GD <sup>2</sup> kgm <sup>2</sup>	Weight kg
			Full load 100%	3/4 load 75%	1/2 load 50%		I <sub>n</sub> , A	I <sub>s</sub> /I <sub>n</sub>	T <sub>n</sub> Nm	T <sub>s</sub> /T <sub>n</sub>	T <sub>b</sub> /T <sub>n</sub>		
		1500 r/min = 4 poles		415V, 50Hz									
0.25	M2AAX71MD4	1415	73.5	70.4	63.9	0.64	0.72	4.6	1.68	2.3	2.5	0.00075	7
0.37	M2AAX71MC4	1415	77.3	76.0	67.0	0.65	1.02	4.6	2.5	2.5	2.8	0.00098	8
0.55	M2AAX80MC4	1435	80.8	80.0	75.0	0.70	1.35	6.0	3.7	2.5	2.8	0.00195	11
0.75	M2AAX80MD4	1445	82.5	81.1	77.1	0.70	2.05	4.5	5.0	3.5	3.9	0.00309	14
1.1	M2AAX90SB4	1435	84.1	83.7	81.0	0.70	2.60	6.0	7.3	3.0	3.7	0.00397	15
1.5	M2AAX90LB4	1431	85.3	85.2	82.9	0.75	3.50	6.0	10.0	3.5	3.9	0.00486	18

Output KW	Frame Size	Speed r/min	Efficiency			Power factor cos $\phi$	Current		Torque			Moment of inertia J=1/4GD <sup>2</sup> kgm <sup>2</sup>	Weight kg
			Full load 100%	3/4 load 75%	1/2 load 50%		I <sub>n</sub> , A	I <sub>s</sub> /I <sub>n</sub>	T <sub>n</sub> Nm	T <sub>s</sub> /T <sub>n</sub>	T <sub>b</sub> /T <sub>n</sub>		
		1000 r/min = 6 poles		415V, 50Hz									
0.18	M2AAX71MC6	931	63.9	60.9	55.0	0.65	0.70	3.3	1.85	2.3	2.6	0.00103	6
0.25	M2AAX71MD6	931	68.6	65.6	59.3	0.65	0.82	3.6	2.56	2.5	2.8	0.00140	8
0.37	M2AAX80MC6	931	73.5	73.0	67.0	0.65	1.15	3.9	3.8	2.5	2.8	0.00220	10
0.55	M2AAX80MD6	935	77.2	77.0	71.5	0.59	1.70	4.5	5.6	2.8	3.3	0.00349	13
0.75	M2AAX90SB6	940	78.9	77.5	73.2	0.63	2.1	4.5	7.6	2.3	3.0	0.00487	18
1.1	M2AAX90LB6	945	81.0	79.7	75.4	0.61	3.1	4.5	11.1	3.0	3.6	0.00676	21

Efficiency values are measured according to IEC 60034-2-1; 2007, IS 15999(Part2/Sec1):2011  
Please note that the values are not comparable without knowing the testing method. ABB has calculated the efficiency values according to indirect method, stray load losses (additional losses) determined from measuring.

I<sub>s</sub> / I<sub>n</sub> = Starting current  
T<sub>s</sub> / T<sub>n</sub> = Locked rotor torque  
T<sub>b</sub> / T<sub>n</sub> = Breakdown

## Dimension drawings

General performance IE2, IE3 high efficiency aluminum motors Sizes 71 - 90

Foot-mounted motor IM1001, B3

Flange-mounted motor IM 3001, B5

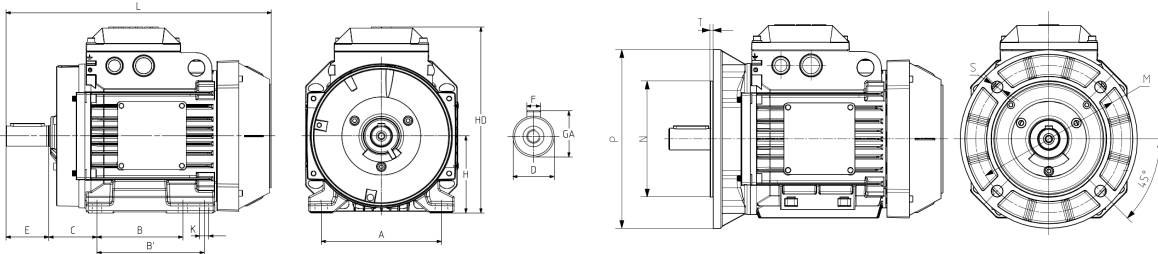

Motor Size	D Poles		GA Poles		F Poles		E Poles		L max Poles		A	B	B'	C	HD	K	H	M	N	P	S	T
	2	4-8	2	4-8	2	4-8	2	4-8	2	4-8												
<b>General performance aluminum motors</b>																						
71M	14	14	16.0	16.0	5	5	30	30	257	257 <sup>1)</sup>	112	90	-	45	180	7	71	130	110	160	10	3.5
80M	19	19	21.5	21.5	6	6	40	40	266	266 <sup>2)</sup>	125	100	-	50	194	10	80	165	130	200	12	3.5
90SL	24	24	27	27.0	8	8	50	50	309	309 <sup>3)</sup>	140	100	125	56	218	10	90	165	130	200	12	3.5

1) IE3: M2AAX71C4,D6 L=270  
 2) IE2: M2AAX80B4,B6, IE3: M2AAX80D2,C4,D6 L=294  
 IE3: M2AAX80D4 L=304  
 3) IE2: M2AAX90LA4B4,LA6, IE3:M2AAX90LB2,LB4,SB6 L=331  
 IE3: M2AAX90LB6 L=349

Above table gives the main dimensions in mm.

For detail dimensions, refer to respective GAD

## Motors in brief

General performance IE2, IE3 high efficiency aluminum motors in brief

Size	71	80	90	
<b>Stator</b>	Material	Die-cast aluminum alloy		
	Paint colour shade	Munsell blue 8B 4.5/3.25 / NCS 4822 B05G		
	Surface Treatment	C3 medium according to ISO / EN 12944-5		
<b>Feet</b>	Integrated with stator			
	Material	Die-cast aluminum alloy		
<b>Bearing end shields</b>	Material	Die-cast aluminum alloy		
	Paint colour shade	Munsell blue 8B 4.5/3.25/NCS 4822 B05G		
	Surface Treatment	C3 medium according to ISO / EN 12944-5		
<b>Bearings</b>	D-end	6203-2Z/C3	6204-2Z/C3	6205-2Z/C3
	N-end	6202-2Z/C3	6203-2Z/C3	6204-2Z/C3
<b>Axially-locked</b>	locked at D-end	With retaining ring	With bearing cover	
<b>Bearing seals</b>	Axial seal as standard, radial on request			
<b>Lubrication</b>	Permanently lubricated shielded bearings			
<b>Rating plate</b>	Material	Aluminum		
<b>Terminal Box</b>	Frame material	Die-cast aluminum alloy		
	Cover material	Die-cast aluminum alloy		
	Cover screws material	Self tapping screws 8.8		
<b>Connections</b>	Cable entries	2xM20	1xM20, 1xM25	
	Cable Sizes	4mm <sup>2</sup>		
	Terminal Stud Size	M4		
	Terminals	Upto 2HP - STAR / 3 Leads > 2 HP - DELTA / 6 Leads, (Cable lugs not included)		
<b>Fan</b>	Material	Polypropylene, Reinforced with glass fibre		
	Material	Polypropylene, Reinforced with glass fibre		
<b>Fan Cover</b>	Paint Colour shade	Munsell blue 8B 4.5/3.25/NCS 4822 B05G		
	Material	Copper		
<b>Stator winding</b>	Insulation	Insulation class F, Temperature rise class B unless otherwise stated		
	Winding protection	Available as option		
	Material	Pressure diecast aluminum		
<b>Balancing method</b>	Half Key Balancing as Standard			
<b>Key ways</b>	Closed Key Way			
<b>Enclosure</b>	IP 55, Higher protection on request			
<b>Cooling method</b>	IC 411			
<b>Drain holes</b>	Drain holes with closable plastic plugs, open on delivery			
<b>Lifting lugs</b>	Integrated with the stator			

## Application note

Aluminum motors are used for various applications where low weight is preferred. Aluminum has reduced weight due to its relatively low density. Also due to its anti corrosive properties & better finishing, these motors are preferred in applications like Food and Beverage that require clean environment. Better heat dissipation of Aluminum motors make it more reliable for longer operations.

With more than 130 years of manufacturing experience we make sure the motors we supply will continue to operate reliably well into the future. ABB has been manufacturing Aluminum motors globally and catering to various segments since decades.

ABB Aluminum motors are highly acclaimed in the market due to its high performance and ensuring a reliable service over the lifetime. These motors are highly efficient for energy cost savings, as well as competitive delivery times.

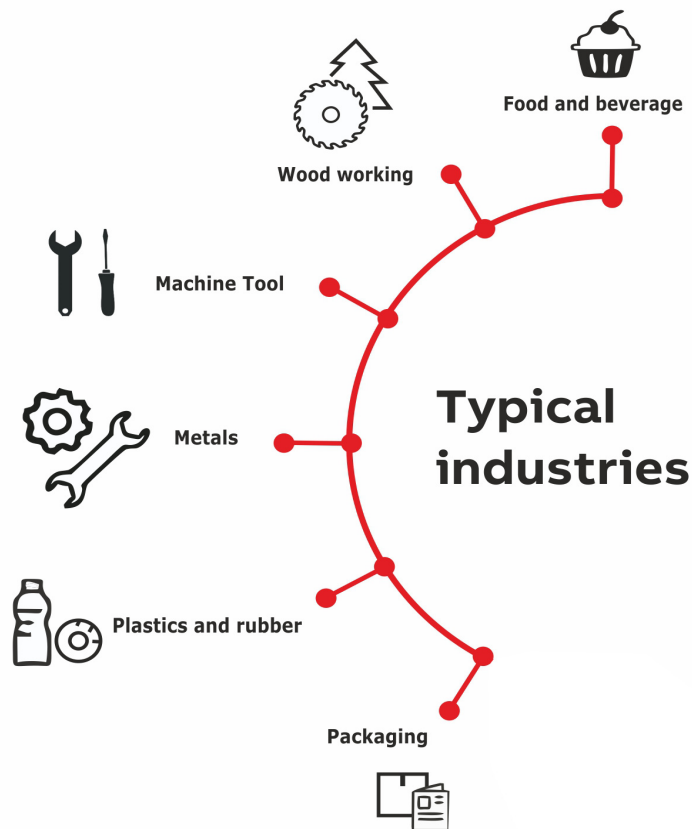







—  
**ABB India Limited**

32, Industrial Area,  
N.I.T., Faridabad - 121 001  
Tel: +91 129 2448100

**[www.abb.co.in](http://www.abb.co.in)**

We reserve the right to make technical changes or modify the contents of this document without prior notice. With regard to purchase orders, the agreed particulars shall prevail. ABB does not accept any responsibility whatsoever for potential errors or possible lack of information in this document.

We reserve all rights in this document and in the subject matter and illustrations contained therein. Any reproduction, disclosure to third parties or utilization of its content - in whole or in parts - is forbidden without ABB's prior written consent.



---

## **LOW VOLTAGE**

Process performance high  
output cast iron motors

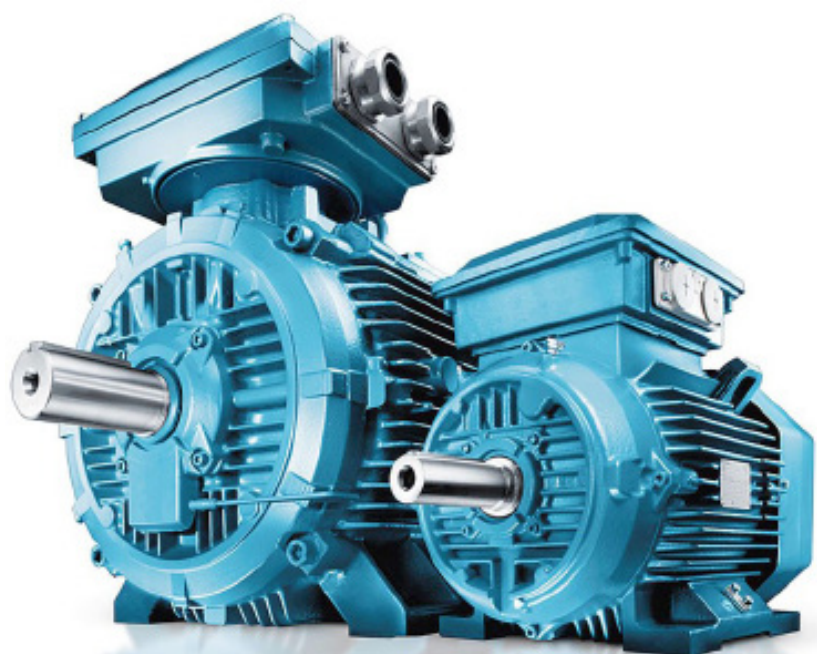

—  
**With expertise and a comprehensive portfolio of products and life-cycle services, we help value-minded industrial customers improve their energy efficiency and productivity.**

---

## **Table of contents**

<b>004</b>	<b>Process Performance</b>
<b>005</b>	<b>Technical Data</b>
<b>006</b>	<b>Dimension Drawings</b>
<b>007</b>	<b>Motors in brief</b>
<b>008</b>	<b>Dimensions and mounting</b>

# Process performance cast iron motors

High output induction motors are high quality products designed for durability in the most demanding environments and tough applications. They are ideally suited to process industries and heavy duty applications – sectors like mining, cement and paper - where motors have to meet high requirements for reliability, availability and efficiency in harsh conditions.

### New improved design

M3BP High output process performance motors in frame sizes 280,315 & 355. The new motors have improved electrical design to meet the requirements.

The new motors are compact and have improved lifting possibilities. The motor frames are also available for smart sensor.

Process performance cast iron motors, M3BP	Value
Frame sizes	280,315 & 355
Pole numbers	2,4,6
Product type	M3BP
Availability	Production

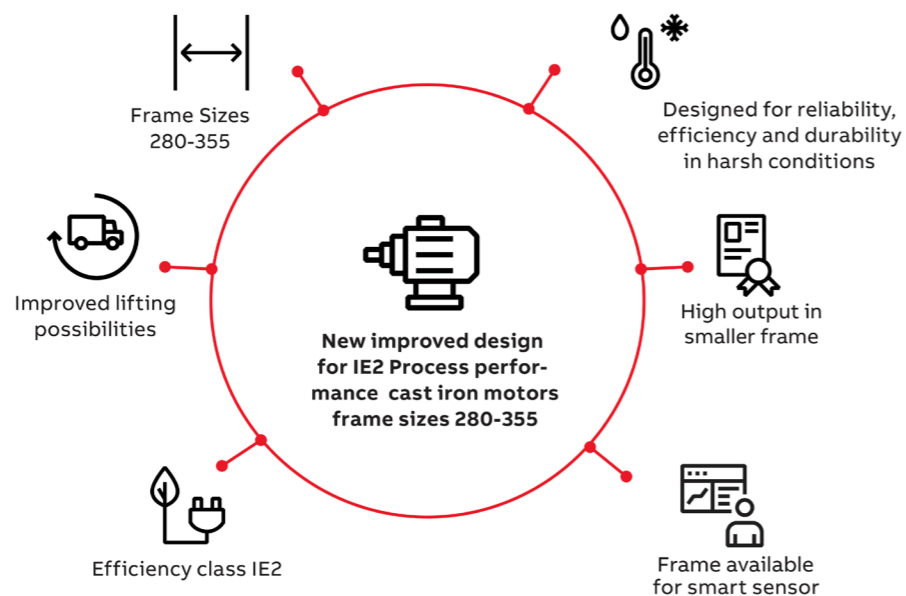

# Technical data

IP55 - IC 411 - Insulation class F, Ambient 45°C (Temp rise class B, 75°C), S1 Duty, IE2 efficiency class according to IS 12615:2018, IEC 60034-30-1, 2014, 415V ± 10%, 50 ± 5% Hz, Combined Variation 10% (absolute)

### 2 Pole, 3000 rev/min.

Out put (kW)	Motor Type	Product Code	Speed (r/min)	Efficiency			Power factor			Current		Torque			Moment of inertia J = 1/4 GD2 (kgm2)	Weight	Sound pressure level LPA (dB)
				FL 100%	FL 75%	FL 50%	100%	75%	50%	In (A)	Is/In (%)	Tn	Ts/Tn	Tmax/Tn			
110	M3BP 280SMC 2	3GBP2 81230-ADG	2980	95.0	95.0	94.0	0.88	<b>0.86</b>	0.82	183	7.0	<b>352</b>	2.5	3.2	1.1	725	90
132	M3BP 280MLA 2	3GBP2 81410-ADG	2978	95.2	95.2	94.2	0.88	<b>0.86</b>	0.82	219	7.0	<b>423</b>	2.7	3.2	1.4	840	90
160	M3BP 280MLB 2	3GBP2 81420-ADG	2978	95.4	95.4	94.4	0.89	<b>0.86</b>	0.83	262	7.0	<b>513</b>	3.0	3.2	1.5	890	90
250	M3BP 315LKA 2	3GBP3 11810-ADG	2982	95.5	95.5	94.5	0.88	<b>0.86</b>	0.82	414	7.0	<b>801</b>	3.0	3.2	2.7	1440	90
315	M3BP 315LKC 2	3GBP3 11830-ADG	2983	95.5	95.5	94.5	0.88	<b>0.86</b>	0.81	521	7.0	<b>1008</b>	3.4	3.4	3.3	1630	90
400	M3BP 355MLA 2	3GBP3 51410-ADG	2984	95.5	95.5	94.5	0.85	<b>0.83</b>	0.77	685	7.0	<b>1280</b>	2.4	3.0	4.1	2000	90
450	M3BP 355MLB 2	3GBP3 51420-ADG	2985	95.5	95.5	94.5	0.88	<b>0.85</b>	0.80	745	7.0	<b>1440</b>	2.3	3.5	4.3	2080	90
500	M3BP 355LKA 2	3GBP3 51810-ADG	2983	95.5	95.5	94.5	0.89	<b>0.86</b>	0.80	818	7.0	<b>1601</b>	2.2	4.0	4.8	2320	90
560	M3BP 355LKB 2	3GBP3 51820-ADG	2984	95.5	95.5	94.5	0.88	<b>0.85</b>	0.80	927	7.0	<b>1792</b>	2.3	4.2	5.2	2460	90

### 4 Pole, 1500 rev/min.

110	M3BP 280SMC 4	3GBP282230-ADG	1486	95.1	95.1	94.1	0.85	<b>0.81</b>	0.72	189	7.0	<b>707</b>	3.2	3.2	1.9	725	85
132	M3BP 280MLA 4	3GBP282410-ADG	1485	95.3	95.3	94.3	0.85	<b>0.81</b>	0.73	227	7.0	<b>848</b>	2.9	3.0	2.3	840	85
160	M3BP 280MLB 4	3GBP282420-ADG	1485	95.5	95.5	94.5	0.84	<b>0.79</b>	0.70	278	7.0	<b>1029</b>	3.1	3.1	2.5	890	85
250	M3BP 315LKA 4	3GBP312810-ADG	1488	95.5	95.5	94.5	0.84	<b>0.80</b>	0.72	434	7.0	<b>1604</b>	2.7	3.1	4.4	1410	85
280	M3BP 315LKB 4	3GBP312820-ADG	1488	95.5	95.5	94.5	0.86	<b>0.83</b>	0.75	474	7.0	<b>1797</b>	2.8	3.3	5.0	1520	85
315	M3BP 315LKC 4	3GBP312830-ADG	1489	95.5	95.5	94.5	0.85	<b>0.82</b>	0.72	540	7.0	<b>2020</b>	2.8	3.4	5.5	1600	85
400	M3BP 355MLA 4	3GBP352410-ADG	1490	95.5	95.5	94.5	0.83	<b>0.80</b>	0.70	702	7.0	<b>2563</b>	2.4	2.7	8.4	2140	85
450	M3BP 355MLB 4	3GBP352420-ADG	1491	95.5	95.5	94.5	0.83	<b>0.80</b>	0.69	790	7.0	<b>2882</b>	2.4	3.0	8.4	2140	85
500	M3BP 355LKA 4	3GBP352810-ADG	1491	95.5	95.5	94.5	0.84	<b>0.80</b>	0.70	867	7.0	<b>3202</b>	2.1	3.2	10.0	2500	85

### 6 Pole, 1000 rev/min.

75	M3BP 280SMC 6	3GBP283230-ADG	991	94.3	94.3	93.3	0.83	<b>0.80</b>	0.72	133	7.0	<b>723</b>	3.0	2.9	2.8	725	85
90	M3BP 280MLA 6	3GBP283410-ADG	990	94.1	94.1	93.1	0.79	<b>0.74</b>	0.64	168	7.0	<b>868</b>	2.6	2.7	3.1	840	85
110	M3BP 280MLB 6	3GBP283420-ADG	991	94.4	94.4	93.4	0.80	<b>0.75</b>	0.65	203	7.0	<b>1060</b>	2.9	2.8	4.1	890	85
160	M3BP 315LKA 6	3GBP313810-ADG	992	95.3	95.3	94.3	0.82	<b>0.77</b>	0.67	285	7.0	<b>1540</b>	2.8	3.0	7.3	1410	85
180	M3BP 315LKB 6	3GBP313820-ADG	992	95.4	95.4	94.4	0.82	<b>0.78</b>	0.68	320	7.0	<b>1733</b>	2.9	3.1	8.3	1520	85
200	M3BP 315LKC 6	3GBP313830-ADG	990	95.5	95.5	94.5	0.84	<b>0.81</b>	0.73	347	7.0	<b>1929</b>	2.7	2.8	9.2	1600	85
355	M3BP 355LKA 6	3GBP353810-ADG	993	95.5	95.5	94.5	0.79	<b>0.73</b>	0.62	655	7.0	<b>3414</b>	2.8	3.0	15.5	2500	85
400	M3BP 355LKB 6	3GBP353820-ADG	993	95.5	95.5	94.5	0.81	<b>0.75</b>	0.62	719	7.0	<b>3846</b>	2.6	2.8	16.5	2600	85

\* 2 pole - Unidirection Fan from 200kW to 560kW - Direction of rotation must be stated when ordering, see variant codes 044 and 045.  
**In** = Nominal or rated current      **Is** = Starting current      **Note:** 1. All performance figures are subject to IEC/IS tolerances.  
**Tn** = Nominal or rated torque in Nm      **Ts** = Starting Torque      2. For Higher Ambient requirement contact sales team  
**Tmax** = Maximum torque

## Dimensions drawings

### Process performance IE2 efficiency cast iron motors

Foot-mounted motor IM1001, B3 and Flange-mounted motor IM 3001, B5

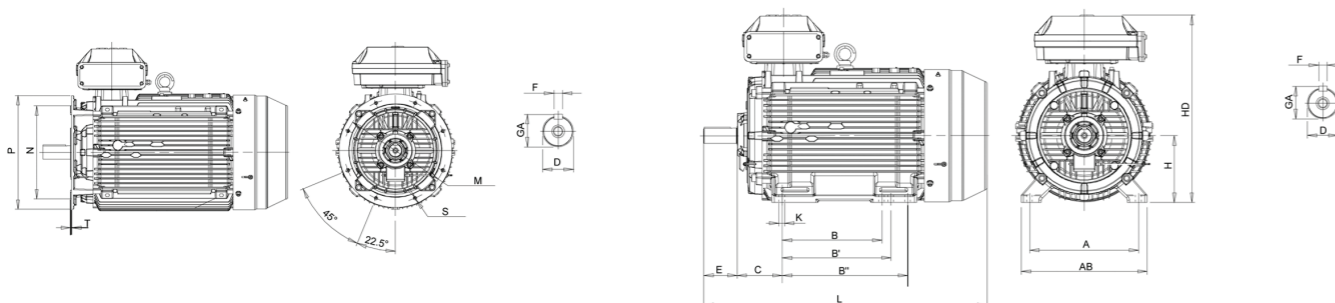

Motor size	D		GA		F		F		L MAX		A	B	B1	C	HD	K	H	M	N	P	S
	2	4-8	2	4-8	2	4-8	2	4-8	2	4-8											
280SM_	65	75	69	79.5	18	20	140	140	1053	1054	457	368	419	190	785	24	280	500	450	550	19
280ML_	65	75	69	79.5	18	20	140	140	1189	1189	457	368	419	190	785	24	280	500	450	550	19
315 SA	65	80	69	85	18	22	140	170	1088	1118	508	406	--	216	845	28	315	600	550	660	24
315 SM_	65	80	69	85	18	22	140	170	1190	1220	508	406	457	216	845	28	315	600	550	660	24
315 ML_	65	90	69	95	18	25	140	170	1285	1315	508	457	508	216	852	30	315	600	550	660	24
315 LK_	65	90	69	95	18	25	140	170	1491	1521	508	457	508	216	880	30	315	600	550	660	24
355 SM_	70	100	74.5	106	20	28	140	210	1409	1479	610	500	560	254	958	35	355	740	680	800	24
355 ML_	70	100	74.5	106	20	28	140	210	1514	1584	610	560	630	254	958	35	355	740	680	800	24
355 LK_	70	100	74.5	106	20	28	140	210	1764	1834	610	710	900	254	958	35	355	740	680	800	24

## Motors in brief

### Process performance cast iron motors M3BP 280-355 High output

Output	280	315	355		
Stator and end shields	Material	Cast iron			
	Paint colour shade	Munshell blue 8B 4.5/3.25			
	Corrosion class	C3 (medium)			
Feet	Material	Integrated cast iron feet			
Bearings	D-End	2-pole	6316/C3	6316/C3	6316M/C3
		4-6 pole	6316/C3	6319/C3	6322/C3
	N-End	2-pole	6316/C3	6316/C3	6316M/C3
		4-6 pole	6316/C3	6316/C3	6316/C3
Axially-locked bearings	Locked at D-end				
Bearing seals	D-End	V-ring or labrinth seal			
	N-End	V-ring or labrinth seal			
Lubrication	Regreasable bearings, regreasing nipples M10 x 1				
Measuring nipple for condition monitoring of the bearings	Included				
Rating plate	Material	Stainless steel			
Terminal box	Frame and cover	Cast iron	Cover steel		
	Corrosion class	C3 (medium)	Steel		
	Cover screws	Zinc-electroplated steel			
Connections	Cable entries	Refer cable details below			
	Terminals	6 terminals of connection (Cable lugs not included)			
	Cable gland	Suitable opening in terminal box, cable glands as option			
Fan	Material	Glass-fiber reinforced polypropylene			
Fan cover	Material	Sheet			
	Paint colour shade	Munshell blue 8B 4.5/3.25			
	Corrosion class	C3 Medium			
Stator winding	Material	Copper			
	Insulation	Insulation class F, temperature rise class B unless otherwise stated			
	Winding protection	3 PTC thermistors, 155°C			
Rotor winding	Material	Pressure diecast aluminium			
Balancing method	Half key balancing				
Key ways	Open key-way				
Drain holes	Drain holes with closable plastic plugs, open on delivery				
Enclosure	IP 55				
Cooling method	IC 411				

#### Cable Details

Rating kW	Maximum Cable Size	Conduit Size	Terminal; Box Type
110	2Rx3Cx240sqmm	2xM63x1.5	370*
132-160	2Rx3Cx240sqmm	2xM63x1.5	370*
250-280	2Rx3Cx240sqmm	2xM63x1.5	750*
315-560	4Rx3Cx240sqmm	4xM63x1.5	750*

\* With adaptor for Cable Entry

CONDITION MONITORING FOR LOW VOLTAGE MOTORS

# Motors that let you know when it's time for service

Monitoring and maintenance of low voltage motors installed across a plant is time consuming and expensive

Failures or oversized motors add unnecessary costs

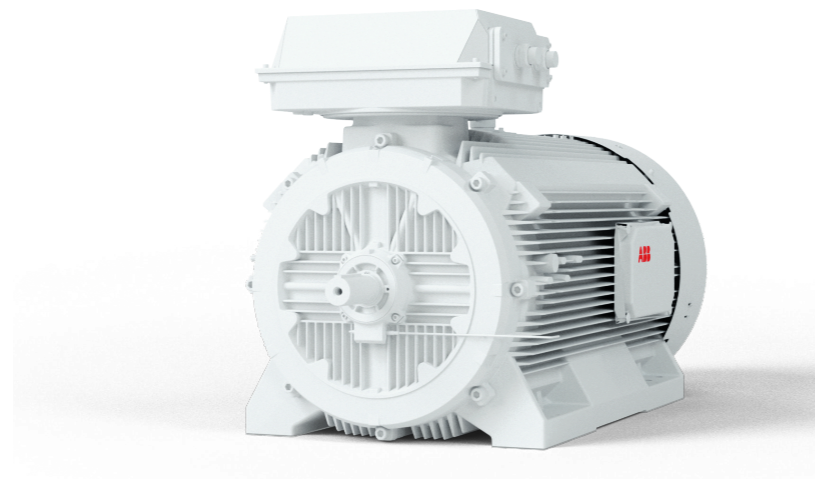

**Many parts of the plant operate in "yesterday's world"**

Nothing being sent, nothing being received. No value added from smart services.

**Industrie 2.0**

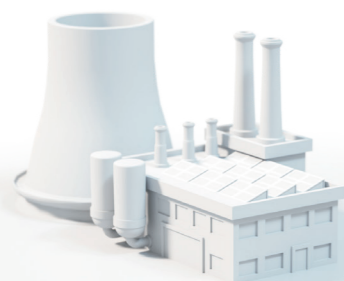

**Industrie 4.0**

Tomorrow's factory is smart, because it communicates



It gathers and shares data

**Now millions of motors will become smart**

Making intelligent services real for electric motors!



**ABB Ability™ Smart Sensor**

The gateway to tomorrow's smart factory

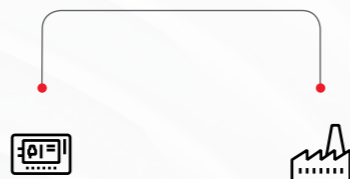

# Your advantages Simply attached directly to the motor

The ABB Ability™ Smart Sensor sends key operating data to the cloud

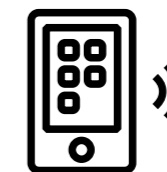

**Motors let you know when it's time for service**

ABB Ability™ Smart Sensor collects condition and performance data frequently



**User-friendly information**



**with reports, performance charts and graphs**



Measured and analysed data provides recommendations on how to optimize operations

**For millions of motors predictive maintenance becomes reality**

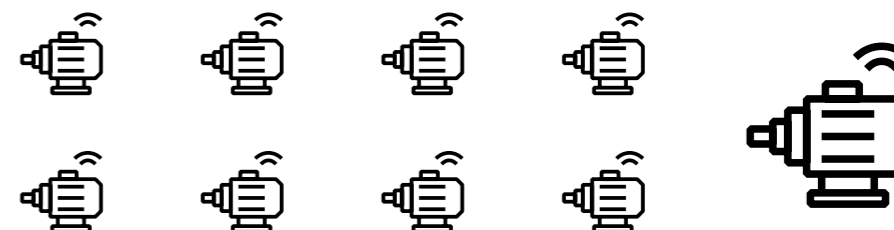





---

**ABB India Limited**

32, Industrial Area,  
N.I.T., Faridabad - 121 001  
Tel: +91 129 2448100

**[www.abb.co.in](http://www.abb.co.in)**

We reserve the right to make technical changes or modify the contents of this document without prior notice. With regard to purchase orders, the agreed particulars shall prevail. ABB does not accept any responsibility whatsoever for potential errors or possible lack of information in this document.

We reserve all rights in this document and in the subject matter and illustrations contained therein. Any reproduction, disclosure to third parties or utilization of its content - in whole or in parts - is forbidden without ABB's prior written consent.

---

## **Low Voltage**

Flameproof motors for explosive gas atmospheres



---

**With expertise, and a comprehensive portfolio of products and life-cycle services, we help value-minded industrial customers improve their energy efficiency and productivity.**

---

# Low voltage flameproof motors for explosive atmospheres

<b>04 - 05</b>	<b>General information</b>
<b>06 - 12</b>	<b>Technical data</b>
<b>13</b>	<b>Dimension drawings</b>
<b>14 - 15</b>	<b>Motors in brief</b>



# General Information

## Introduction

The use of electrical motors in potentially explosive atmospheres is quite frequent these days. These motors have to be constructed in such a way that there is no risk of an explosion. An Explosion occurs when the following situations occur:

- presence of potentially explosive atmosphere
- existence of a source of ignition
- possibility of transmission of the explosion

## Classification of Hazardous Environment

According to IS: 5572, Hazardous areas are classified in the following ways depending on the degree of probability of the presence of hazardous atmosphere.

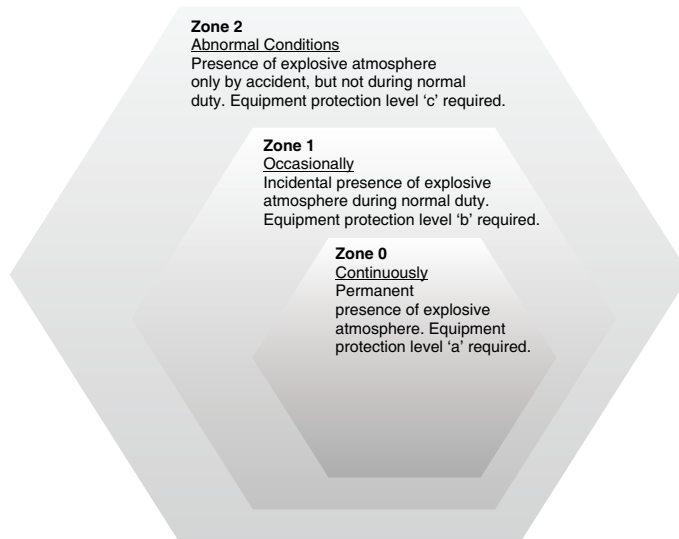

Zone Criteria presence of gas

Zone 0 Continuously or very long period

Zone 1 Present in normal operations

Zone 2 Unlikely, but if present, only for a short time

In Zone 0, no electrical motors can be installed. Most common motor for Zone 1 is the flameproof design, but it can also be used in Zone 2.

## Application Groups

Depending on the intended use, explosion-proof electrical operating equipment is divided into two major groups:

Group I Equipment for coal mines (only specially designed motors for mines can be used)

Group II Electrical equipment for use other than mines (surface industry)

Group II motors with flameproof enclosures are still further divided into gas groups:

II A ~120 gases and vapors, e.g. butane / petroleum / propane

II B ~30 gases and vapors, e.g. ethylene / dimethyl ether

II C limited number of gases and vapors, e.g. hydrogen  $H_2$  / acetylene  $C_2H_2$  / carbon disulfide  $CS_2$

### Temperature Classes

Combustible gas or vapour and explosion-protected electrical equipment are divided into temperature of the gas up to T6 with regard to the ignition temperature of the gas or vapour and the maximum surface temperature of the component.

Temperature class	Ignition temperature for the gas / vapour °C	Maximum permitted temperature of electrical equipment °C
T1	>450	450
T2	>300 <450	300
T3	>200 <300	200
T4	>135 <200	135
T5	>100 <135	100
T6	>85 <100	85

### Flame proof motors, type "db"

ABB motors of flame proof design (type M2JAP) are TEFC, 3 phase squirrel cage induction motor (as per IS/IEC 60079-1:2014) for operation in hazardous location classified as Zone 1 and Zone 2 areas as per IS:5572

The motor enclosure has been designed in such a way that no internal explosion can be transmitted to the explosive atmosphere surrounding the machine. The enclosure must withstand, without damage, any pressure levels caused by an internal explosion, the shape, length and gap of part assembly joints at shaft opening, cable entries, etc., shall be designed to allow for throttling and cooling of hot gases escaping outside. The standard emphasise the impact of an explosive atmosphere (for instance, explosion pressure) over constructional requirements of such apparatus.

Range: 0.18 kW to 55 kW

Frame: M2JAP 80 to 250 frame

Pole: 2 to 8 Pole

### Features

- H Motors suitable for high ambient temperature 45°C.
- H Keeps an explosion which takes place inside the enclosure from propagating through gaps to the ambient.
- H Withstands the explosion pressure created inside the enclosures.
- H Benefits when dealing with special operating modes such as heavy starts and special applications.
- H All surface temperatures are selected to comply with the temperature class.
- H Suitability for use in temperature classes T1 to T4.
- H Can be used both in Zone 1 and Zone 2.

## Technical data for Ex db IIB/IIC T4 Gb

IE2 Ex db cast iron motors, 3000 r/min

IP 55 - IC 411 - Insulation class F, temperature rise class B, Amb. 45 deg,

IE2 efficiency class according to IEC 60034-30-1:2014

Output KW	Motor Type	Product code	Speed r/min	Efficiency			Power factor cos $\phi$	Current		Torque			Moment of inertia $J=1/4GD^2$ kgm <sup>2</sup>	Weight kg
				Full load 100%	3/4 load 75%	1/2 load 50%		$I_n$ , A	$I_s/I_n$	$T_n$ Nm	$T_s/T_n$	$T_b/T_n$		
3000 r/min = 2 poles			415V, 50Hz											
0.75	M2JAP80MB2	3GJA081320-CIN	2900	77.4	75.4	70.3	0.68	2.2	6.5	2.47	3.7	4.5	0.00082	45
1.1	M2JAP80MC2	3GJA081330-CIN	2880	81.8	81.6	79.1	0.77	2.33	7.7	3.63	3.7	3.7	0.00101	47
1.5	M2JAP90SLB2	3GJA091020-CIN	2905	83.4	83.6	81.7	0.86	2.84	7.5	4.92	2.9	3	0.00254	55
2.2	M2JAP90SLC2	3GJA091030-CIN	2878	83.2	83.9	82.3	0.87	4.3	6.5	7.3	2.6	3.1	0.0028	56
3.7	M2JAP100LC2	3GJA101530-CIN	2920	85.5	85.1	83	0.87	6.7	9	12.2	3	3.6	0.00728	75
5.5	M2JAP132SMB2	3GJA131220-CIN	2875	87	87.2	85.8	0.86	9.56	7.5	18.13	2.7	2.9	0.0128	102
7.5	M2JAP132SMC2	3GJA131230-CIN	2890	88.1	88.3	87	0.87	13.3	8.4	24.74	2.6	4.1	0.0136	104
9.3	M2JAP160MLJ2	3GJA161490-CIN	2931	88.9	89	87.9	0.89	16.4	7.1	30.3	2.8	3.4	0.043	213
11	M2JAP160MLA2	3GJA161410-CIN	2936	89.4	89.6	88.4	0.84	20.5	7.1	35.8	2.8	3.4	0.043	213
15	M2JAP160MLB2	3GJA161420-CIN	2934	90.6	90.6	89.5	0.86	27.5	7.6	48.8	3.1	3.6	0.052	222
18.5	M2JAP160MLC2	3GJA161430-CIN	2939	91.7	92.1	91.5	0.89	31.9	7.9	60.15	3.4	3.6	0.062	233
22	M2JAP180MLA2	3GJA181410-CIN	2943	92	92.4	92	0.89	38	7.4	71.3	2.7	3.5	0.089	265
30	M2JAP200MLA2	3GJA201410-CIN	2958	92.8	93.3	93	0.87	52.3	7.5	97.1	2.6	3.5	0.15	310
37	M2JAP200MLC2	3GJA201430-CIN	2958	93.6	93.9	93.4	0.88	63.1	8	119	2.5	3.3	0.19	340
45	M2JAP225SMB2	3GJA221220-CIN	2970	93.9	94	93.1	0.86	78.1	7.6	145	2.6	3.2	0.26	400
55	M2JAP250SMA2	3GJA251210-CIN	2977	94.2	94.2	93.2	0.86	94	7.7	176.7	2.2	3.3	0.49	460

Efficiency values are measured according to IEC 60034-2-1; 2007, IS 15999(Part 2 Sec 1):2011  
Please note that the values are not comparable without knowing the testing method. ABB has calculated the efficiency values according to indirect method, stray load losses (additional losses) determined from measuring.

$I_s / I_n$  = Starting current  
 $T_s / T_n$  = Locked rotor torque  
 $T_b / T_n$  = Breakdown

## Technical data for Ex db IIB/IIC T4 Gb

IE2 Ex db cast iron motors, 1500 r/min

IP 55 - IC 411 - Insulation class F, temperature rise class B, Amb. 45 deg,

IE2 efficiency class according to IEC 60034-30-1:2014

Output KW	Motor Type	Product code	Speed r/min	Efficiency			Power factor cos $\phi$	Current		Torque			Moment of inertia J=1/4GD <sup>2</sup> kgm <sup>2</sup>	Weight kg
				Full load 100%	3/4 load 75%	1/2 load 50%		I <sub>n</sub> , A	I <sub>s</sub> /I <sub>n</sub>	T <sub>n</sub> Nm	T <sub>s</sub> /T <sub>n</sub>	T <sub>b</sub> /T <sub>n</sub>		
1500 r/min = 4 poles				415V, 50Hz										
0.55	M2JAP80MA4	3GJA082310-CIN	1445	77.1	75.9	70.9	0.66	1.52	6.4	3.62	3.6	3.7	0.00237	49
0.75	M2JAP80MD4	3GJA082340-CIN	1435	79.6	79	75.7	0.72	1.86	6	4.98	3.6	3.7	0.00287	40
1.1	M2JAP90SLB4	3GJA092020-CIN	1430	81.4	81.7	79.2	0.78	2.34	7.5	7.2	3.9	4.2	0.0039	55
1.5	M2JAP90SLD4	3GJA092040-CIN	1432	82.8	83	80.7	0.78	3.3	6.7	10	3.2	3.5	0.00437	58
2.2	M2JAP100LC4	3GJA102530-CIN	1450	84.3	83.7	80.3	0.75	4.98	7.8	14.5	3.5	4.3	0.00831	69
3.7	M2JAP112MB4	3GJA112320-CIN	1445	86.3	87.1	86.6	0.74	7.6	7	24.33	2.7	3.4	0.0188	81
5.5	M2JAP132SMB4	3GJA132220-CIN	1460	88.3	88.3	86.6	0.79	11.3	7.1	35.9	2.5	3.4	0.0296	107
7.5	M2JAP132SMC4	3GJA132230-CIN	1460	89	89.3	88	0.78	14.3	7.6	49.3	2.2	3.4	0.0327	110
9.3	M2JAP160MLJ4	3GJA162490-CIN	1460	89.3	89.8	89.3	0.81	17.9	8	60.83	2.7	3.4	0.088	232
11	M2JAP160MLC4	3GJA162430-CIN	1465	90.6	90.7	89.6	0.8	21.3	8.5	71.4	3.2	3.9	0.096	232
15	M2JAP160MLE4	3GJA162450-CIN	1470	91.5	91.8	91.1	0.82	27.8	8.2	97.52	3.2	3.5	0.13	255
18.5	M2JAP180MLA4	3GJA182410-CIN	1476	91.8	92.1	91.3	0.81	36	7.5	119.7	2.7	3.3	0.19	277
22	M2JAP180MLB4	3GJA182420-CIN	1476	92.2	92.3	91.4	0.8	41.7	8.2	142	3	3.6	0.23	296
30	M2JAP200MLB4	3GJA202420-CIN	1473	92.5	93.1	92.9	0.83	53.6	7	194	2.6	2.8	0.34	340
37	M2JAP225SMB4	3GJA222220-CIN	1482	93.6	93.5	92.4	0.83	67.2	7.6	238	3.1	3.2	0.42	390
45	M2JAP225SMC4	3GJA222230-CIN	1479	93.8	94.1	93.6	0.85	79.6	7	291	2.8	2.9	0.49	425
55	M2JAP250SMA4	3GJA252210-CIN	1480	94.5	94.8	94.4	0.83	98.8	7.5	355	2.7	3.3	0.72	415

Efficiency values are measured according to IEC 60034-2-1; 2007, IS 15999(Part2 Sec1):2011  
 Please note that the values are not comparable without knowing the testing method. ABB has calculated the efficiency values according to indirect method, stray load losses (additional losses) determined from measuring.

I<sub>s</sub> / I<sub>n</sub> = Starting current  
 T<sub>s</sub> / T<sub>n</sub> = Locked rotor torque  
 T<sub>b</sub> / T<sub>n</sub> = Breakdown

## Technical data for Ex db IIB/IIC T4 Gb

IE2 Ex db cast iron motors, 1000 r/min

IP 55 - IC 411 - Insulation class F, temperature rise class B, Amb. 45 deg,

IE2 efficiency class according to IEC 60034-30-1:2014

Output KW	Motor Type	Product code	Speed r/min	Efficiency			Power factor cos $\phi$	Current		Torque			Moment of inertia J=1/4GD <sup>2</sup> kgm <sup>2</sup>	Weight kg
				Full load 100%	3/4 load 75%	1/2 load 50%		I <sub>n</sub> , A	I <sub>s</sub> /I <sub>n</sub>	T <sub>n</sub> Nm	T <sub>s</sub> /T <sub>n</sub>	T <sub>b</sub> /T <sub>n</sub>		
1000 r/min = 6 poles			415V, 50Hz											
0.25	M2JAP80MJ6	3GJA083390-CIN	941	61.6	58.9	50.9	0.6	0.79	2.6	2.52	1.6	2.1	0.0019	44
0.37	M2JAP80MA6	3GJA083310-CIN	930	67.6	67.4	62.8	0.65	1.11	4.3	3.8	2.5	2.7	0.00187	44
0.55	M2JAP80MB6	3GJA083320-CIN	925	73.1	73.9	70	0.69	1.53	3.9	5.6	2	2.4	0.00239	46
0.75	M2JAP90SLC6	3GJA093030-CIN	942	75.9	75.2	69.8	0.62	2.22	4	7.46	2.9	3.1	0.00392	56
1.1	M2JAP90SLE6	3GJA093050-CIN	940	78.2	78.1	74.5	0.64	2.9	3.9	11.1	2.1	2.5	0.006	59
1.5	M2JAP100L6	3GJA103500-CIN	955	81.4	81.5	79.3	0.68	3.72	4.4	15.04	1.6	2.9	0.00873	67
2.2	M2JAP112MC6	3GJA113330-CIN	952	84.2	85.5	84.9	0.7	5.1	4	22.1	1.3	1.9	0.0196	82
3.7	M2JAP132SMJ6	3GJA133290-CIN	960	84.3	84.3	81	0.69	8.8	7	36.8	1.6	2.2	0.0299	106
5.5	M2JAP132SMF6	3GJA133260-CIN	965	86	85.9	83.9	0.76	11.3	5.8	54.0	1.7	2.5	0.084	106
7.5	M2JAP160MLA6	3GJA163410-CIN	967	87.8	88.3	87.6	0.77	15.4	6.9	74.03	1.9	3.2	0.126	253
9.3	M2JAP160MLJ6	3GJA163490-CIN	970	88.1	88.4	87.2	0.77	21.6	7.4	92	2.6	3.5	0.116	253
11	M2JAP160MLB6	3GJA163420-CIN	974	90.1	90.7	89.8	0.79	21.6	7.4	108	2.5	3.9	0.126	253
15	M2JAP180MLB6	3GJA183420-CIN	975	89.8	90.3	89.3	0.8	29.3	7.2	147	2	3.3	0.25	304
18.5	M2JAP200MLA6	3GJA203410-CIN	984	91	91.2	90.2	0.8	35.6	6.7	180	2.6	3.3	0.37	300
22	M2JAP200MLB6	3GJA203420-CIN	984	91.6	91.8	91	0.81	42.3	7.0	213	2.9	3.3	0.43	320
30	M2JAP225SMB6	3GJA223220-CIN	986	92.2	92.4	91.6	0.81	57.3	7.8	291	3	3.2	0.64	385
37	M2JAP250SMA6	3GJA253210-CIN	991	92.2	92.5	91.8	0.81	68.9	6.7	357	2.8	3.3	1.16	455

Efficiency values are measured according to IEC 60034-2-1; 2007, IS 15999(Part 2 Sec 1):2011  
Please note that the values are not comparable without knowing the testing method. ABB has calculated the efficiency values according to indirect method, stray load losses (additional losses) determined from measuring.

I<sub>s</sub> / I<sub>n</sub> = Starting current  
T<sub>s</sub> / T<sub>n</sub> = Locked rotor torque  
T<sub>b</sub> / T<sub>n</sub> = Breakdown

## Technical data for Ex db IIB/IIC T4 Gb

### IE2 Ex db cast iron motors, 750 r/min

IP 55 - IC 411 - Insulation class F, temperature rise class B, Amb. 45 deg,  
IE2 efficiency class according to IEC 60034-30-1:2014

Output KW	Motor Type	Product code	Speed r/min	Efficiency			Power factor cos $\phi$	Current		Torque			Moment of inertia J=1/4GD <sup>2</sup> kgm <sup>2</sup>	Weight kg
				Full load 100%	3/4 load 75%	1/2 load 50%		I <sub>n</sub> , A	I <sub>s</sub> /I <sub>n</sub>	T <sub>n</sub> Nm	T <sub>s</sub> /T <sub>n</sub>	T <sub>b</sub> /T <sub>n</sub>		
750 r/min = 8 poles			415V, 50Hz											
0.18	M2JAP80MA8	3GJA084310-CIN	685	45.9	44.5	36.8	0.57	0.72	3	2.5	2.1	2.6	0.0019	45
0.25	M2JAP80MB8	3GJA084320-CIN	690	50.6	50.4	44.6	0.59	0.97	3.1	3.47	2.1	2.4	0.0024	46
0.37	M2JAP90SLB8	3GJA094020-CIN	710	56.1	53.9	46.1	0.54	1.5	3	4.9	2	2.4	0.0044	55
0.55	M2JAP90SLC8	3GJA094030-CIN	680	61.7	62.6	58	0.57	2.11	2.7	7.72	1.6	1.9	0.0049	56
0.75	M2JAP100LA8	3GJA104510-CIN	710	72.5	70.9	65.7	0.56	2.56	3.7	10	1.9	2.8	0.0072	64
1.1	M2JAP100LB8	3GJA104520-CIN	705	74.9	74.5	70.8	0.61	3.18	3.5	14.8	1.7	2.4	0.00871	67
1.5	M2JAP112MC8	3GJA114330-CIN	713	79.6	80.7	79.7	0.63	4.1	3.8	20.1	1.4	2.2	0.0198	81
2.2	M2JAP132SMA8	3GJA134210-CIN	720	77.6	76.5	73	0.59	6.69	4.8	29.1	1.7	3	0.0299	106
3.7	M2JAP160MLJ8	3GJA164490-CIN	723	81.4	81.4	79.5	0.67	9.5	6	48.8	1.7	2.7	0.133	251
5.5	M2JAP160MLB8	3GJA164420-CIN	725	86.3	86.5	85	0.69	13.6	6.1	72.5	2	3.4	0.133	251
7.5	M2JAP160MLC8	3GJA164430-CIN	721	85.3	85.3	83.5	0.67	19	6	99.4	1.8	3.1	0.133	251
9.3	M2JAP180MLJ8	3GJA184490-CIN	725	86.3	86.3	83.6	0.62	21.6	5.9	122.5	2.1	2.9	0.226	298
11	M2JAP180MLB8	3GJA184420-CIN	725	88.4	88.4	86.9	0.7	25.3	6.1	145	2.2	3.3	0.245	298
15	M2JAP200MLA8	3GJA204410-CIN	735	90	89.4	88.3	0.77	30.2	7.2	195	2.4	3.5	0.45	315
18.5	M2JAP225SMA8	3GJA224210-CIN	735	90	90.1	88.7	0.72	40.2	6.1	240	1.9	3.3	0.61	370
22	M2JAP225SMB8	3GJA224220-CIN	733	90.7	91	90.1	0.75	45	6.8	287	2.1	3.1	0.68	350
30	M2JAP250SMA8	3GJA254210-CIN	736	91.7	91.9	90.9	0.77	60	7	389	2.2	3.1	1.25	420

Efficiency values are measured according to IEC 60034-2-1; 2007, IS 15999(Part2 Sec1):2011  
Please note that the values are not comparable without knowing the testing method. ABB has calculated the efficiency values according to indirect method, stray load losses (additional losses) determined from measuring.

I<sub>s</sub> / I<sub>n</sub> = Starting current  
T<sub>s</sub> / T<sub>n</sub> = Locked rotor torque  
T<sub>b</sub> / T<sub>n</sub> = Breakdown

## Technical data for Ex db IIB/IIC T4 Gb

IE3 Ex db cast iron motors, 3000 r/min

IP 55 - IC 411 - Insulation class F, temperature rise class B, Amb. 45 deg,  
IE3 efficiency class according to IEC 60034-30-1:2014

Output KW	Motor Type	Product code	Speed r/min	Efficiency			Power factor cos $\phi$	Current		Torque			Moment of inertia $J=1/4GD^2$ kgm <sup>2</sup>	Weight kg
				Full load 100%	3/4 load 75%	1/2 load 50%		$I_n$ , A	$I_s/I_n$	$T_n$ Nm	$T_s/T_n$	$T_b/T_n$		
3000 r/min = 2 poles			415V, 50Hz											
0.75	M2JAP80MD2	3GJA081340-DIN	2872	80.7	81.6	80.3	0.86	1.58	7.6	2.5	3.3	4	0.0012	49
1.1	M2JAP80MG2	3GJA081370-DIN	2870	82.7	83.2	81.9	0.84	2.31	7.4	3.65	3.3	3.8	0.00121	49
1.5	M2JAP90SLB2	3GJA091020-DIN	2897	84.2	85.8	85.2	0.89	2.83	8	4.94	3.5	3.9	0.0031	60
2.2	M2JAP90LC2	3GJA091530-DIN	2908	85.9	86.4	85.1	0.89	3.9	8.4	7.27	3.4	3.8	0.0044	63
3.7	M2JAP100LKB2	3GJA101820-DIN	2900	87.8	87.6	87	0.89	6.6	8.5	12.2	2.7	2.9	0.0086	75
5.5	M2JAP132SMF2	3GJA131260-DIN	2909	90.8	91.4	90.8	0.9	9.3	7.8	18.2	2.6	3.6	0.0218	124
7.5	M2JAP132SMG2	3GJA131270-DIN	2914	91.6	92.3	92.1	0.9	12.6	8	24.7	2.8	3.7	0.0218	124
9.3	M2JAP160MLJ2	3GJA161490-DIN	2946	90.7	91	90.2	0.9	15.9	7.7	30.14	2.7	3.7	0.0513	213
11	M2JAP160MLA2	3GJA161410-DIN	2946	91.2	91.8	91.3	0.9	18.8	7.7	35.52	2.8	3.9	0.057	225
15	M2JAP160MLB2	3GJA161420-DIN	2960	91.9	92	91.4	0.86	26.2	8.7	48.54	3.1	4.1	0.063	232
18.5	M2JAP160MLC2	3GJA161430-DIN	2952	92.4	92.9	92.3	0.89	31.1	9.6	59.74	3.6	4.2	0.076	246
22	M2JAP180MLA2	3GJA181410-DIN	2959	92.7	93.1	92.5	0.89	36.7	8.4	71	3.6	4.1	0.11	282
30	M2JAP200MLA2	3GJA201410-DIN	2961	93.3	93.6	93.3	0.87	51.1	8.1	96.8	2.8	3.3	0.182	332
37	M2JAP200MLB2	3GJA201420-DIN	2963	93.7	94.1	93.9	0.88	62.1	8.8	119.37	3.3	3.6	0.222	359
45	M2JAP225SMA2	3GJA221210-DIN	2970	94	93.9	92.9	0.85	78.3	7.7	144.69	2.7	3.3	0.296	405
55	M2JAP250SMA2	3GJA251210-DIN	2970	94.3	94.1	93.5	0.89	92.1	7.3	177	2.5	3.1	0.426	470

Efficiency values are measured according to IEC 60034-2-1; 2007, IS 15999(Part2 Sec1):2011  
Please note that the values are not comparable without knowing the testing method. ABB has  
calculated the efficiency values according to indirect method, stray load losses (additional losses)  
determined from measuring.

$I_s / I_n$  = Starting current  
 $T_s / T_n$  = Locked rotor torque  
 $T_b / T_n$  = Breakdown

## Technical data for Ex db IIB/IIC T4 Gb

IE3 Ex db cast iron motors, 1500 r/min

IP 55 - IC 411 - Insulation class F, temperature rise class B, Amb. 45 deg,  
IE3 efficiency class according to IEC 60034-30-1:2014

Output KW	Motor Type	Product code	Speed r/min	Efficiency			Power factor cos $\phi$	Current		Torque			Moment of inertia J=1/4GD <sup>2</sup> kgm <sup>2</sup>	Weight kg
				Full load 100%	3/4 load 75%	1/2 load 50%		I <sub>n</sub> , A	I <sub>s</sub> /I <sub>n</sub>	T <sub>n</sub> Nm	T <sub>s</sub> /T <sub>n</sub>	T <sub>b</sub> /T <sub>n</sub>		
1500 r/min = 4 poles				415V, 50Hz										
0.55	M2JAP80MLD4	3GJA082440-DIN	1444	83.3	84.1	83	0.79	1.16	6.6	3.6	2.9	3.5	0.0028	49
0.75	M2JAP80MLG4	3GJA082470-DIN	1445	82.5	82.5	79.9	0.77	1.72	7	4.94	2.8	3.4	0.0033	50
1.1	M2JAP90SLC4	3GJA092030-DIN	1440	84.1	83.9	81.7	0.78	2.34	7.6	7.25	3.9	4.2	0.0067	61
1.5	M2JAP90LD4	3GJA092540-DIN	1446	85.3	86.0	85.0	0.76	3.1	8.2	9.95	3.6	4.8	0.0072	62
2.2	M2JAP100LKA4	3GJA102810-DIN	1455	86.7	86.9	85.5	0.84	4.22	8	14.4	3.5	4.3	0.0146	79
3.7	M2JAP112MF4	3GJA112360-DIN	1458	88.4	88.7	87.8	0.76	7.7	7.9	24.2	2.6	3.3	0.0188	81
5.5	M2JAP132SMF4	3GJA132260-DIN	1462	89.6	89.9	88.8	0.82	10.6	7.3	35.79	2.1	3.4	0.0401	119
7.5	M2JAP132SMG4	3GJA132270-DIN	1460	90.4	90.9	90.2	0.82	14.4	7.3	49	2.2	3.3	0.0401	119
9.3	M2JAP160MLJ4	3GJA162490-DIN	1470	91	90.6	89.1	0.81	17.9	8.2	60.4	2.7	3.4	0.0992	240
11	M2JAP160MLA4	3GJA162410-DIN	1479	91.4	91.6	90.7	0.81	20.5	8.2	71.2	2.9	3.6	0.11	240
15	M2JAP160MLB4	3GJA162420-DIN	1478	92.1	92.1	91.1	0.81	27.3	8.8	96.87	3.3	4	0.135	259
18.5	M2JAP180MLA4	3GJA182410-DIN	1482	92.6	93.1	92.6	0.82	34.6	7.8	119.17	2.8	3	0.219	291
22	M2JAP180MLB4	3GJA182420-DIN	1482	93	93.6	93.4	0.8	41.3	8	142	3	3.3	0.217	296
30	M2JAP200MLA4	3GJA202410-DIN	1485	93.6	93.8	93.1	0.83	53.6	7.5	193	2.9	3.5	0.385	360
37	M2JAP225SMA4	3GJA222210-DIN	1483	93.9	93.9	93.4	0.81	67.7	7.6	238.38	3.4	3.4	0.427	394
45	M2JAP225SMB4	3GJA222220-DIN	1483	94.2	94.3	93.8	0.82	81	8.6	290	3.5	3.8	0.525	431
55	M2JAP250SMA4	3GJA252210-DIN	1484	94.6	94.5	93.7	0.82	98.6	7.5	354	3.2	3.6	0.694	442

Efficiency values are measured according to IEC 60034-2-1; 2007, IS 15999(Part2 Sec1):2011  
Please note that the values are not comparable without knowing the testing method. ABB has calculated the efficiency values according to indirect method, stray load losses (additional losses) determined from measuring.

I<sub>s</sub> / I<sub>n</sub> = Starting current  
T<sub>s</sub> / T<sub>n</sub> = Locked rotor torque  
T<sub>b</sub> / T<sub>n</sub> = Breakdown

## Technical data for Ex db IIB/IIC T4 Gb

IE3 Ex db cast iron motors, 1000 r/min

IP 55 - IC 411 - Insulation class F, temperature rise class B, Amb. 45 deg,  
IE3 efficiency class according to IEC 60034-30-1:2014

Output KW	Motor Type	Product code	Speed r/min	Efficiency			Power factor cos $\phi$	Current		Torque			Moment of inertia $J=1/4GD^2$ kgm <sup>2</sup>	Weight kg
				Full load 100%	3/4 load 75%	1/2 load 50%		$I_n$ , A	$I_s/I_n$	$T_n$ Nm	$T_s/T_n$	$T_b/T_n$		
1000 r/min = 6 poles				415V, 50Hz										
0.25	M2JAP80MA6	3GJA083310-DIN	941	72.6	70.7	65	0.6	0.79	2.6	2.52	1.5	2.1	0.0019	44
0.37	M2JAP80MD6	3GJA083340-DIN	935	74.4	74.7	71.6	0.68	1	4.7	3.75	3	3.5	0.0028	47
0.55	M2JAP80MLG6	3GJA083470-DIN	941	80.6	80.7	78.6	0.6	1.58	4.6	5.6	2	2.4	0.0044	51
0.75	M2JAP90SLD6	3GJA093040-DIN	945	78.9	79.8	78.2	0.73	1.7	4.7	7.57	2.3	3	0.0056	58
1.1	M2JAP90LF6	3GJA093560-DIN	949	81	82.4	81.8	0.73	2.5	5	11.1	2.3	3.1	0.0068	61
1.5	M2JAP100LE6	3GJA103550-DIN	963	82.5	82.7	80.8	0.65	3.8	5.7	14.9	3	3.7	0.012	74
2.2	M2JAP112MJ6	3GJA113390-DIN	964	84.3	84.2	82	0.66	5.3	6.2	21.8	2.5	3.6	0.0196	82
3.7	M2JAP132SMJ6	3GJA133290-DIN	975	86.5	86.7	86	0.68	8.8	7.5	36.2	1.9	2.7	0.0416	106
5.5	M2JAP132SMH6	3GJA133280-DIN	968	88	88.6	88	0.63	13.5	5.2	54.1	2	2.9	0.0654	118
7.5	M2JAP160MLA6	3GJA163410-DIN	976	89.1	89.7	89.4	0.76	15.4	6.1	73.1	1.5	3.3	0.089	225
9.3	M2JAP160MLJ6	3GJA163490-DIN	970	89.8	90.1	89.3	0.77	18.7	7.1	92	2.1	3	0.128	259
11	M2JAP160MLB6	3GJA163420-DIN	977	90.3	91	90.6	0.77	22	6.9	107.29	1.8	3.4	0.138	259
15	M2JAP180MLA6	3GJA183410-DIN	980	91.2	91.7	91.1	0.77	29.6	5.5	146	1.7	2.9	0.212	288
18.5	M2JAP200MLA6	3GJA203410-DIN	990	91.7	91.8	90.9	0.81	34.5	7.8	178.6	2.8	3.5	0.496	340
22	M2JAP200MLB6	3GJA203420-DIN	990	92.2	92.2	91	0.79	41.9	7.8	212.2	2.9	3.8	0.585	367
30	M2JAP225SMA6	3GJA223210-DIN	989	92.9	92.6	91	0.73	61.8	8	290	3.1	3.7	0.724	419
37	M2JAP250SMA6	3GJA253210-DIN	990	93.3	93.6	93.2	0.79	69.8	7	357	2.6	3.4	1.3	503

Efficiency values are measured according to IEC 60034-2-1; 2007, IS 15999(Part2 Sec1):2011  
Please note that the values are not comparable without knowing the testing method. ABB has  
calculated the efficiency values according to indirect method, stray load losses (additional losses)  
determined from measuring.

$I_s / I_n$  = Starting current  
 $T_s / T_n$  = Locked rotor torque  
 $T_b / T_n$  = Breakdown

## Dimension drawings

Flameproof motors, Ex db, Sizes 80 - 250

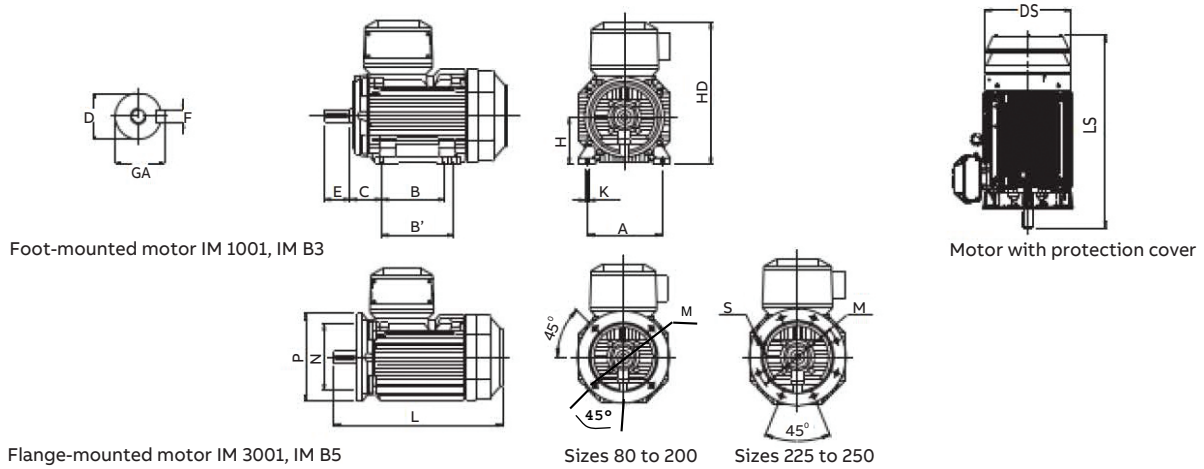

Foot-mounted motor IM 1001, IM B3

Motor with protection cover

Flange-mounted motor IM 3001, IM B5

Sizes 80 to 200

Sizes 225 to 250

Flameproof motors Ex db, foot-mounted IM 1001 / IM B3, flange-mounted IM 3001 / IM B5.

Motor size	IM 1001, IM B3 AND IM 3001, IM B5										IM 1001, IM B3					IM 3001, IM B5					Protective roof				
	D poles		GA poles		F poles		E poles		L max poles		O <sup>1)</sup>	A	B	B'	C	HD	K	H	M	N	P	S	DS	LS poles	
	2	4-8	2	4-8	2	4-8	2	4-8	2	4-8													2	4-8	
80	19	19	21.5	21.5	6	6	40	40	409	409	20	125	100	112	50	296	10	80	165	130	200	12	157	444	444
90	24	24	27	27	8	8	50	50	440	440	20	140	100	125	56	315	10	90	165	130	200	12	185	475	475
100	28	28	31	31	8	8	60	60	501	501	25	160	140	160	63	343	12	100	215	180	250	14.5	200	536	536
112	28	28	31	31	8	8	60	60	485	485	25	190	140	-	70	355	12	112	215	180	250	14.5	213	526	526
132	38	38	41	41	10	10	80	80	531 <sup>(3)</sup>	531 <sup>(3)</sup>	30	216	140	178	89	392	12	132	265	230	300	14.5	274	582	582
132 <sup>2)</sup>	38	38	41	41	10	10	80	80	576	576	30	216	140	178	89	392	12	132	265	230	300	14.5	274	627	627
160	42	42	45	45	12	12	110	110	808	808	45	254	210	254	108	495	14.5	160	300	250	350	18.5	328	852	852
180	48	48	51.5	51.5	14	14	110	110	826	826	50	279	241	279	121	535	14.5	180	300	250	350	18.5	359	876	876
200	55	55	59	59	16	16	110	110	774	774	70	318	267	305	133	616	18.5	200	350	300	400	18.5	414	844	844
200 <sup>2)</sup>	55	55	59	59	16	16	110	110	824	824	70	318	267	305	133	616	18.5	200	350	300	400	18.5	414	844	844
225	55	60	59	64	16	18	110	140	841	871	80	356	286	311	149	663	18.5	225	400	350	450	18.5	462	921	951
225 <sup>2)</sup>	55	60	59	64	16	18	110	140	871	901	80	356	286	311	149	663	18.5	225	400	350	450	18.5	462	921	951
250	60	65	64	69	18	18	140	140	875	875	90	406	311	349	168	726	24	250	500	450	550	18.5	506	965	965
250 <sup>2)</sup>	60	65	64	69	18	18	140	140	895	895	90	406	311	349	168	726	24	250	500	450	550	18.5	506	965	965

<sup>1)</sup> Required distance from fan cover air inlet to obstacle behind motor

<sup>2)</sup> For IE3 version

<sup>3)</sup> 576 for M2JAP132SMF6

### Available B14 alternatives

Flange size	Motor Size	Flange dimension			
		P	M	N	S
Ft100	80	120	100	80	M6
Ft115	90	140	115	95	M8
Ft130	100/112	160	130	110	M8
Ft165	132	200	165	130	M10

Above table gives the main dimensions in mm

## Motors in brief

Flameproof motors Ex db, Sizes 80-180

Motor size		80	90	100	112	132	160	180
Stator	Material	Cast iron, EN-GJL-200 or better						
	Paint color shade	Blue, Munsell 8B 4.5/3.25						
	Corrosion class	C3						
Feet		Cast iron, EN-GJL-200 or better, integrated with stator						
Bearing end shields	Material	Cast iron, EN-GJL-200 or better						
	Paint colour shade	Blue, Munsell 8B 4.5/3.25						
	Corrosion class	C3						
Bearings	D-end 2-8 poles	6205-2Z/C3	6205-2Z/C3	6206-2Z/C3	6206-2Z/C3	6208-2Z/C3	6309-2Z/C3	6310-2Z/C3
	N-end 2-8 poles	6204-2Z/C3	6204-2Z/C3	6205-2Z/C3	6206-2Z/C3	6208-2Z/C3	6309-2Z/C3	6310-2Z/C3
Axially locked bearings	Bearing cover	As standard, locked at D-end						
Bearing seals		Gamma ring						
Lubrication		Permanent grease lubrication						
SPM nipples		-						As option
Rating plate	Material	Stainless steel						
Terminal box	Frame material	Cast iron, EN-GJL-200 or better						
	Cover material	Cast iron, EN-GJL-200 or better						
	Cover screws material	Steel 8.8, zinc electroplated and chromated						
Connections	Cable entries	1 x M25		2 x M32		2 x M40		
	Terminals	6 terminals for connection with cable lugs (not included)						
Fan	Material	Polypropylene. Reinforced with glass fibre.						
Fan cover	Material	Steel						
	Paint color shade	Munsell blue 8B 4.5/3.25						
	Corrosion class	C3						
Stator winding	Material	Copper						
	Insulation	Insulation class F						
	Winding protection	3 pcs thermistors as option						
Rotor winding	Material	Pressure die-cast aluminum						
Balancing		Half-key balancing						
Keyway		Closed						
Heating elements	On request	25 W						
Drain holes		-						Optional
External earthing bolt		As standard						
Enclosure		IP 55						
Cooling method		IC 411						

## Motors in brief

Flameproof motors Ex db, Sizes 200-250

Motor size		200	225	250
Stator	Material	Cast iron, EN-GJL-200 or better		
	Paint color shade	Munsell blue 8B 4.5/3.25		
	Corrosion class	C3		
Feet	Material	Cast iron, EN-GJL-200 or better, integrated with stator		
Bearing end shields	Material	Cast iron, EN-GJL-200 or better		
	Paint colour shade	Blue, Munsell 8B 4.5/3.25		
	Corrosion class	C3		
Bearings	D-end 2-8 pole	6312-2Z/C3	6313-2Z/C3	6315-2Z/C3
	N-end 2-8 pole	6310-2Z/C3	6312-2Z/C3	6313-2Z/C3
Axially locked bearing covers	Bearing cover bearings	As standard, locked at D-end		
Bearing seals		Gamma ring		
Lubrication		Permanent grease lubrication		
SPM nipples		As option		
Rating plate	Material	Stainless steel		
Terminal box	Frame material	Cast iron, EN-GJL-200 or better		
	Cover material	Cast iron, EN-GJL-200 or better		
	Cover screws material	Steel 8.8, zinc electroplated and chromated		
Connections	Cable-entries	2 x M50		
	Terminals	6 terminals for connection with cable lugs (not included)		
Fan	Material	Polypropylene. Reinforced with glass fibre.		
Fan cover	Material	Steel		
	Paint color shade	Munsell blue 8B 4.5/3.25		
	Corrosion class	C3		
Stator winding	Material	Copper		
	Insulation	Insulation class F		
	Winding protection	3 pcs thermistors as option		
Rotor winding	Material	Pressure die-cast aluminum		
Balancing		Half key balancing		
Keyway		Closed		
Heating elements	On request	25 W	60 W	
Drain holes		Optional		
External earthing bolt		As standard		
Enclosure		IP 55		
Cooling method		IC 411		

---

**ABB India Limited**

32, Industrial Area,  
N.I.T., Faridabad - 121 001  
Tel: +91 129 2448100

**[www.abb.co.in](http://www.abb.co.in)**

We reserve the right to make technical changes or modify the contents of this document without prior notice. With regard to purchase orders, the agreed particulars shall prevail. ABB does not accept any responsibility whatsoever for potential errors or possible lack of information in this document.

We reserve all rights in this document and in the subject matter and illustrations contained therein. Any reproduction, disclosure to third parties or utilization of its content - in whole or in parts - is forbidden without ABB's prior written consent.

06/2022



---

## Low Voltage

Smoke Extraction

IE2, IE3 efficiency cast iron motors

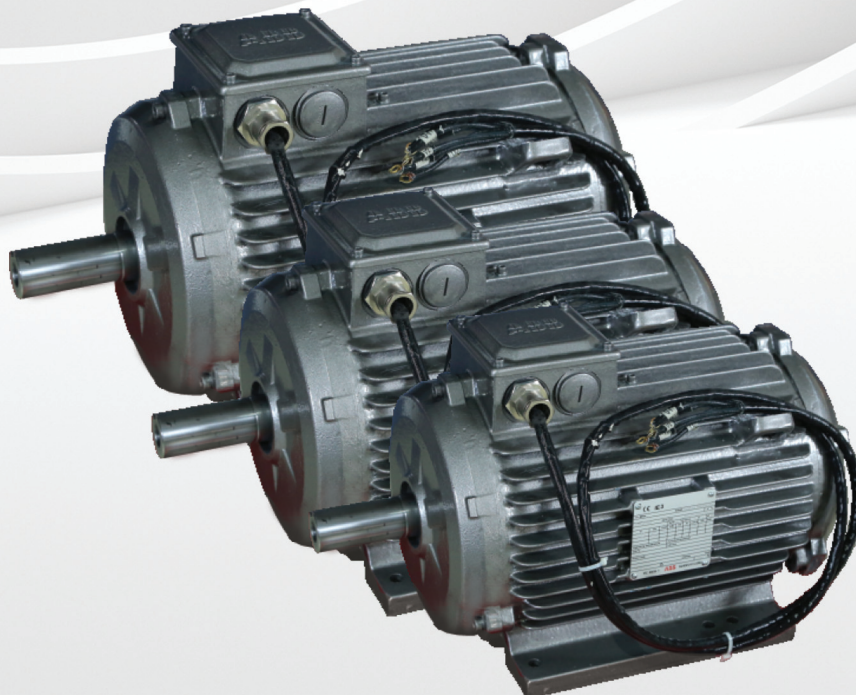

---

**ABB's smoke extraction motors comply with the global standards and offer maximum performance in both normal operation and emergency conditions. Designed and certified for direct online starting, the IE2 and IE3 smoke extraction motors meet all challenging demands of end users and serial OEMs.**

---

# Smoke extraction IE2, IE3 efficiency motors

## Frame sizes 71 to 250

- 04-07**      **Technical data IE2, IE3  
Cast iron motors**
- 08**         **Dimension drawings IE2, IE3  
Cast iron motors**
- 09-10**     **General performance motors  
in brief - Cast iron motors**
- 11**         **ABB Ability™ Smart Sensor**



---

### Outstanding features

- IE2 and IE3 efficiency motors, complying with Indian efficiency standard
- High Reliability
- Available in TEFC and TEAO
- Insulation Class H & VPI by default
- Following Operating temperature and functioning period available
  - 250°C for 120 min
  - 300°C for 60 min
  - 300°C for 120 min
- Motors are tested and certified by external agency as per BS EN 12101-3:2002

## Technical data

Smoke extraction IE2 efficiency cast iron motors

Technical data for totally enclosed squirrel cage three phase induction motors

IP 55 - IC 418 & IC 411 - Insulation class H, temperature rise class F  
IE2 efficiency class according to IS 12615:2018

Output KW	Frame Size	Speed r/min	Efficiency			Power factor cos $\phi$	Current		Torque			Moment of inertia J=1/4GD <sup>2</sup> kgm <sup>2</sup>	Weight kg
			Full load 100%	3/4 load 75%	1/2 load 50%		I <sub>n</sub> , A	I <sub>s</sub> /I <sub>n</sub>	T <sub>n</sub> ,Nm	T <sub>s</sub> /T <sub>n</sub>	T <sub>b</sub> /T <sub>n</sub>		
		3000 r/min	415V, 50Hz										
0.37	S2BAX71MA2	2760	72.2	72.9	70.3	0.79	0.90	5.0	1.3	2.0	2.4	0.00033	9
0.55	S2BAX71MB2	2785	74.8	75.5	73	0.79	1.30	5.0	1.9	2.2	2.7	0.00041	10
0.75	S2BAX80MA2	2820	77.4	78.0	75.7	0.79	1.70	6.0	2.5	2.3	2.8	0.00067	13
1.1	S2BAX80MB2	2840	79.6	80.0	77.9	0.77	2.5	6.0	3.7	2.5	3.0	0.00088	14
1.5	S2BAX90SA2	2875	81.3	82.0	80.3	0.83	3.1	6.0	5.0	2.3	3.0	0.00208	20
2.2	S2BAX90LA2	2878	83.2	84.0	82.6	0.84	4.4	7.0	7.3	2.5	3.1	0.00274	23
3.7	S2BAX100LC2	2890	85.5	85.8	84.3	0.87	6.9	7.0	12.2	3.0	3.8	0.00561	34
5.5	S2BAX132SA2	2915	87.0	87.8	86.7	0.84	10.5	7.0	18.0	2.0	3.4	0.01170	54
7.5	S2BAX132SB2	2910	88.1	89.0	88.7	0.86	13.8	7.0	24.6	2.1	3.5	0.01320	58
9.3	S2BAX160MLJ2	2925	88.8	89.1	87.6	0.87	16.7	7.0	30.3	2.1	3.0	0.038	102
11	S2BAX160MLA2	2925	89.4	89.7	88.2	0.88	19.6	7.0	35.9	3.1	2.9	0.0415	105
15	S2BAX160MLB2	2928	90.3	90.7	90.0	0.87	26.5	7.0	48.9	2.1	3.0	0.0544	120
18.5	S2BAX160MLC2	2928	90.9	91.2	90.4	0.87	32.4	7.0	60.3	2.3	3.0	0.0581	131
22	S2BAX180MLA2	2932	91.3	91.7	91.0	0.88	38.0	7.0	71.6	2.6	3.2	0.0679	152
30	S2BAX200MLA2	2935	92.0	92.4	91.5	0.88	51.5	7.0	97.6	2.2	3.2	0.1077	198
37	S2BAX200MLB2	2950	92.5	92.8	91.7	0.87	64.0	7.0	119.7	3.0	3.8	0.1332	232
45	S2BAX225SMA2	2960	92.9	92.6	92.0	0.88	77.0	7.0	145.1	2.2	3.0	0.2443	295
55	S2BAX250SMA2	2965	93.2	93.8	92.8	0.89	92.0	7.0	177.1	2.5	3.0	0.316	344

Output KW	Frame Size	Speed r/min	Efficiency			Power factor cos $\phi$	Current		Torque			Moment of inertia J=1/4GD <sup>2</sup> kgm <sup>2</sup>	Weight kg
			Full load 100%	3/4 load 75%	1/2 load 50%		I <sub>n</sub> , A	I <sub>s</sub> /I <sub>n</sub>	T <sub>n</sub> ,Nm	T <sub>s</sub> /T <sub>n</sub>	T <sub>b</sub> /T <sub>n</sub>		
		1500 r/min	415V, 50Hz										
0.37	S2BAX71MB4	1395	72.7	72.0	68.0	0.65	1.10	5.0	2.5	1.9	2.2	0.00076	10
0.55	S2BAX80MA4	1415	77.1	76.0	71.0	0.71	1.40	5.0	3.7	2.2	2.8	0.00156	15
0.75	S2BAX80MB4	1425	79.6	78.5	74.3	0.67	1.97	6.0	5.0	3.0	3.5	0.00247	17
1.1	S2BAX90SA4	1430	81.4	80.6	76.8	0.74	2.55	6.0	7.3	3.0	3.5	0.00372	21
1.5	S2BAX90LA4	1430	82.8	82.2	79.4	0.73	3.47	6.0	10.0	3.0	3.5	0.00462	23
2.2	S2BAX100LA4	1435	84.3	84.2	82.1	0.76	4.8	7.0	14.6	2.6	3.3	0.00759	31
3.7	S2BAX112MA4	1435	86.3	86.9	85.9	0.80	7.5	7.0	24.6	2.8	3.3	0.01200	41
5.5	S2BAX132SA4	1450	87.7	88.4	87.6	0.79	11.1	6.0	36.2	1.7	2.8	0.02570	57
7.5	S2BAX132MA4	1455	88.7	89.2	88.3	0.77	15.3	6.0	49.2	1.7	3.0	0.03200	68
9.3	S2BAX160MLJ4	1455	89.3	89.8	88.0	0.81	17.9	7.0	61.0	2.0	2.9	0.0738	107
11	S2BAX160MLA4	1455	89.8	90.4	89.4	0.81	21.0	7.0	72.2	2.1	2.9	0.084	115
15	S2BAX160MLB4	1460	90.6	91.2	90.2	0.81	28.4	7.0	98.0	2.5	3.0	0.1025	134
18.5	S2BAX180MLA4	1457	91.2	91.8	90.9	0.81	35.0	7.0	121.2	2.7	3.5	0.1217	155
22	S2BAX180MLB4	1460	91.6	92.1	91.2	0.80	42.0	7.0	143.8	2.4	3.2	0.1396	171
30	S2BAX200MLA4	1474	92.3	92.5	91.8	0.81	55.5	7.0	194.3	2.5	3.1	0.2572	229
37	S2BAX225SMA4	1475	92.7	93.1	92.2	0.84	66.5	6.5	239.4	2.1	2.7	0.3605	267
45	S2BAX225SMB4	1478	93.1	93.5	92.6	0.83	81.5	7.0	290.6	2.2	2.9	0.4314	304
55	S2BAX250SMA4	1478	93.5	93.7	92.9	0.85	96.8	7.0	355.2	2.7	3.0	0.5331	342

## Technical data

Smoke extraction IE2 efficiency cast iron motors

Technical data for totally enclosed squirrel cage three phase induction motors

IP 55 - IC 418 & IC 411 - Insulation class H, temperature rise class F  
IE2 efficiency class according to IS 12615:2018

Output KW	Frame Size	Speed r/min	Efficiency			Power factor cos $\phi$	Current		Torque			Moment of inertia J=1/4GD <sup>2</sup> kgm <sup>2</sup>	Weight kg
			Full load 100%	3/4 load 75%	1/2 load 50%		I <sub>n</sub> , A	I <sub>s</sub> /I <sub>n</sub>	T <sub>n</sub> ,Nm	T <sub>s</sub> /T <sub>n</sub>	T <sub>b</sub> /T <sub>n</sub>		
		1000 r/min	415V, 50Hz										
0.37	S2BAX80MA6	910	69.0	68.1	63.1	0.62	1.20	4.0	3.9	2.0	2.4	0.00173	13
0.55	S2BAX80MB6	910	73.1	72.8	69.2	0.66	1.60	4.0	5.8	2.1	2.5	0.00274	15
0.75	S2BAX90SA6	945	75.9	74.3	69.2	0.62	2.2	4.5	7.6	2.4	3.2	0.00438	21
1.1	S2BAX90LA6	935	78.1	77.3	73.3	0.63	3.1	4.5	11.2	2.3	2.9	0.00507	24
1.5	S2BAX100LA6	945	79.8	79.7	77.0	0.67	3.9	4.5	15.2	1.8	2.3	0.00795	31
2.2	S2BAX112MA6	950	81.8	81.7	79.0	0.68	5.5	5.0	22.1	1.8	2.6	0.01160	40
3.7	S2BAX132SB6	960	84.3	84.7	83.4	0.71	8.6	5.0	36.8	1.5	2.3	0.02830	60
5.5	S2BA132MB6	965	86.0	86.0	84.2	0.70	12.7	5.0	54.4	1.5	2.8	0.03970	77
7.5	S2BAX160MLA6	957	87.2	88.0	86.8	0.77	15.6	6.5	74.8	1.7	2.6	0.089	122
9.3	S2BAX160MLJ6	965	88.0	88.6	87.8	0.77	19.1	6.5	92.0	2.0	2.8	0.119	141
11	S2BAX160MLB6	965	88.7	89.2	88.5	0.75	23.0	7.0	108.8	2.1	2.8	0.1293	147
15	S2BAX180MLA6	970	89.7	90.1	89.4	0.76	30.5	7.0	147.6	2.0	3.0	0.1522	173
18.5	S2BAX200MLA6	965	90.4	90.8	90.0	0.77	37.0	6.0	183.0	1.5	2.5	0.198	190
22	S2BAX200MLB6	970	90.9	91.2	90.6	0.77	43.7	6.0	216.5	1.5	2.5	0.2384	212
30	S2BAX225SMA6	981	91.7	92.0	91.2	0.82	55.8	6.5	291.9	2.1	2.8	0.5687	284
37	S2BAX250SMA6	981	92.2	92.4	91.9	0.81	68.9	6.0	360.0	2.0	2.6	0.8042	337

Efficiency values are given according to IEC 60034-2-1: 2007, IS 15999-2-1.  
Please note that the values are not comparable without knowing the testing method.  
ABB has calculated the efficiency values according to indirect method, stray load losses (additional losses) determined from measuring.

I<sub>s</sub> / I<sub>n</sub> = Starting current  
T<sub>s</sub> / T<sub>n</sub> = Locked rotor torque  
T<sub>b</sub> / T<sub>n</sub> = Breakdown torque

Note : All performance figures are subject to IS tolerances

## Technical data

Smoke extraction IE3 efficiency cast iron motors

Technical data for totally enclosed squirrel cage three phase induction motors

IP 55 - IC 418 & IC 411 - Insulation class H, temperature rise class F  
IE3 efficiency class according to IS 12615:2018

Output KW	Frame Size	Speed r/min	Efficiency			Power factor cos $\phi$	Current		Torque			Moment of inertia J=1/4GD <sup>2</sup> kgm <sup>2</sup>	Weight kg
			Full load 100%	3/4 load 75%	1/2 load 50%		I <sub>n</sub> , A	I <sub>s</sub> /I <sub>n</sub>	T <sub>n</sub> ,Nm	T <sub>s</sub> /T <sub>n</sub>	T <sub>b</sub> /T <sub>n</sub>		
		3000 r/min	415V, 50Hz										
0.37	S3BAX71MC2	2790	75.5	75.4	72.7	0.72	0.95	5.5	1.3	2.1	2.5	0.00033	9
0.55	S3BAX71MB2	2782	78.1	78.4	76.4	0.73	1.35	5.5	1.9	2.1	2.6	0.00041	10
0.75	S3BAX80MC2	2870	80.7	80.0	76.7	0.76	1.7	6.5	2.5	2.8	3.6	0.00080	14
1.1	S3BAX80MD2	2865	82.7	83.3	81.9	0.80	2.3	7.0	3.7	2.8	3.6	0.00119	17
1.5	S3BAX90SB2	2882	84.2	84.6	83.0	0.83	3.0	6.0	5.0	2.7	3.3	0.00224	21
2.2	S3BAX90SLA2	2890	85.9	86.7	85.8	0.88	4.4	7.0	7.3	3.0	3.5	0.00304	25
3.7	S3BAX100LKB2	2900	87.8	88.1	86.8	0.85	6.9	7.7	12.2	3.5	3.9	0.00756	42
5.5	S3BAX132SMA2	2900	89.2	89.6	88.9	0.82	10.5	7.0	18.1	2.1	3.3	0.01625	69
7.5	S3BAX132SMB2	2905	90.1	90.5	89.7	0.82	14.2	6.5	24.7	2.2	3.5	0.01821	74
9.3	S3BAX160MLJ2	2935	90.7	90.8	89.7	0.86	16.6	7.7	30.3	2.5	3.5	0.053	115
11	S3BAX160MLA2	2935	91.2	91.5	90.8	0.87	19.2	7.7	35.8	2.4	3.2	0.057	118
15	S3BAX160MLB2	2940	91.9	92.1	91.3	0.86	26.5	7.7	48.7	2.9	4.0	0.063	126
18.5	S3BAX160MLC2	2950	92.4	92.9	92.5	0.90	33.0	7.7	59.9	3.0	3.9	0.076	144
22	S3BAX180MLA2	2950	92.7	93.2	92.7	0.88	37.7	7.7	71.2	2.6	3.3	0.110	181
30	S3BAX200MLA2	2950	93.3	93.6	93.2	0.89	51.0	7.7	97.1	2.4	2.9	0.182	230
37	S3BAX200MLB2	2955	93.7	94.1	93.6	0.88	62.7	7.7	119.6	2.8	3.4	0.222	257
45	S3BAX225SMA2	2965	94.0	94.1	93.3	0.86	77.7	7.7	144.9	2.8	3.4	0.296	287
55	S3BAX250SMA2	2965	94.3	94.3	93.5	0.87	93.5	7.0	177.2	2.7	3.1	0.426	344

Output KW	Frame Size	Speed r/min	Efficiency			Power factor cos $\phi$	Current		Torque			Moment of inertia J=1/4GD <sup>2</sup> kgm <sup>2</sup>	Weight kg
			Full load 100%	3/4 load 75%	1/2 load 50%		I <sub>n</sub> , A	I <sub>s</sub> /I <sub>n</sub>	T <sub>n</sub> ,Nm	T <sub>s</sub> /T <sub>n</sub>	T <sub>b</sub> /T <sub>n</sub>		
		1500 r/min	415V, 50Hz										
0.37	S3BAX71MLA4	1415	77.3	76.0	67.0	0.65	1.02	4.6	2.5	2.5	2.8	0.00098	12
0.55	S3BAX80MC4	1435	80.8	80.0	75.0	0.70	1.35	6.0	3.7	2.5	2.8	0.00195	17
0.75	S3BAX80MLA4	1445	82.5	81.1	77.1	0.70	2.05	4.5	5.0	3.5	3.9	0.00309	20
1.1	S3BAX90SB4	1435	84.1	83.7	81.0	0.70	2.60	6.0	7.3	3.0	3.7	0.00397	22
1.5	S3BAX90SLA4	1431	85.3	85.2	82.9	0.75	3.50	6.0	10.0	3.5	3.9	0.00486	25
2.2	S3BAX100LB4	1445	86.7	86.9	85.1	0.74	4.8	7.0	14.5	2.9	3.7	0.00919	34
3.7	S3BAX112MLA4	1450	88.4	88.5	87.0	0.76	7.7	7.5	24.4	3.3	3.9	0.01542	50
5.5	S3BAX132SMA4	1460	89.6	90.6	90.2	0.77	11.1	7.0	36.0	2.0	3.0	0.03505	72
7.5	S3BAX132MLA4	1462	90.4	90.9	90.3	0.75	15.4	7.0	48.8	2.1	3.2	0.04108	84
9.3	S3BAX160MLJ4	1470	91.0	90.9	89.5	0.77	18.5	7.5	60.4	2.7	3.5	0.105	130
11	S3BAX160MLA4	1470	91.4	91.5	90.5	0.78	21.6	7.5	71.5	2.6	3.2	0.11	134
15	S3BAX160MLB4	1470	92.1	92.2	91.3	0.80	28.8	7.5	97.4	2.6	3.4	0.135	159
18.5	S3BAX180MLA4	1475	92.6	93.0	92.5	0.80	34.7	7.5	119.8	2.5	3.3	0.219	192
22	S3BAX180MLB4	1475	93.0	93.5	93.0	0.79	41.5	7.5	142.4	2.9	3.5	0.243	205
30	S3BAX200MLA4	1480	93.6	93.8	93.2	0.83	54.0	7.5	193.6	2.9	3.3	0.385	259
37	S3BAX225SMA4	1480	93.9	94.2	93.8	0.80	68.5	7.5	238.8	2.8	3.2	0.427	274
45	S3BAX225SMB4	1480	94.2	94.6	94.3	0.81	82.5	7.5	290.4	2.5	3.1	0.525	307
55	M2BAX250SMA4	1482	94.6	94.7	94.1	0.82	99.0	7.5	354.4	2.6	3.0	0.694	358

## Technical data

Smoke extraction IE3 efficiency cast iron motors

Technical data for totally enclosed squirrel cage three phase induction motors

IP 55 - IC 418 & IC 411 - Insulation class H, temperature rise class F  
IE3 efficiency class according to IS 12615:2018

Output KW	Frame Size	Speed r/min	Efficiency			Power factor cos $\phi$	Current		Torque			Moment of inertia J=1/4GD <sup>2</sup> kgm <sup>2</sup>	Weight kg
			Full load 100%	3/4 load 75%	1/2 load 50%		I <sub>n</sub> , A	I <sub>s</sub> /I <sub>n</sub>	T <sub>n</sub> ,Nm	T <sub>s</sub> /T <sub>n</sub>	T <sub>b</sub> /T <sub>n</sub>		
1000 r/min		415V, 50Hz											
0.37	S3BAX80MC6	931	73.5	73.0	67.0	0.65	1.15	3.9	3.8	2.5	2.8	0.00220	15
0.55	S3BAX80MLA6	935	77.2	77.0	71.5	0.59	1.70	4.5	5.6	2.8	3.3	0.00349	19
0.75	S3BAX90SLA6	940	78.9	77.5	73.2	0.63	2.1	4.5	7.6	2.3	3.0	0.00487	25
1.1	S3BAX90LB6	945	81.0	79.7	75.4	0.61	3.1	4.5	11.1	3	3.6	0.00676	30
1.5	S3BAX100LKA6	954	82.5	82.6	80.2	0.67	3.8	4.5	15.0	2.2	2.4	0.00994	37
2.2	S3BAX112MLA6	952	84.3	84.4	82.5	0.66	5.5	5.0	22.1	1.9	2.7	0.01388	47
3.7	S3BAX132SMB6	960	86.5	87.0	86.0	0.68	8.8	5.0	36.8	1.6	2.7	0.03540	72
5.5	S3BAX132MLA6	965	88.0	88.3	87.3	0.68	12.7	5.0	54.4	1.6	2.8	0.05334	97
7.5	S3BAX160MLA6	965	89.1	90.2	90.0	0.72	16.2	6.5	74.2	1.8	3.1	0.089	119
9.3	S3BAX160MLJ6	970	89.8	90.3	89.7	0.70	20.6	6.5	91.5	1.9	3.1	0.128	153
11	S3BAX160MLB6	970	90.3	91.0	90.7	0.74	23.0	6.5	108.2	1.7	2.6	0.138	160
15	S3BAX180MLA6	972	91.2	91.6	91.0	0.72	31.8	6.0	147.3	1.8	2.8	0.212	190
18.5	S3BAX200MLA6	980	91.7	91.8	90.9	0.80	35.0	7.0	180.2	2.2	3.1	0.496	238
22	S3BAX200MLB6	986	92.2	92.2	91.1	0.79	42.3	7.5	213.0	2.3	3.4	0.585	263
30	S3BAX225SMA6	982	92.9	93.0	92.0	0.76	59.0	7.5	291.6	2.3	3.0	0.724	285
37	S3BAX250SMA6	985	93.3	93.7	93.4	0.80	69.3	7.0	358.6	2.1	2.5	1.3	379

Efficiency values are given according to IEC 60034-2-1: 2007, IS 15999-2-1.

Please note that the values are not comparable without knowing the testing method.

ABB has calculated the efficiency values according to indirect method, stray load losses (additional losses) determined from measuring.

I<sub>s</sub> / I<sub>n</sub> = Starting current

T<sub>s</sub> / T<sub>n</sub> = Locked rotor torque

T<sub>b</sub> / T<sub>n</sub> = Breakdown torque

Note : All performance figures are subject to IS tolerances

## Dimension drawings

Smoke extraction IE2, IE3 efficiency motors size 71-250

Foot-mounted motor IM1001, B3 (TEAO)

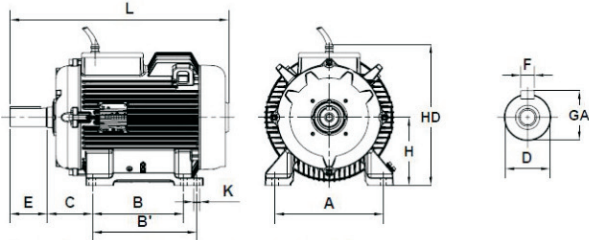

Flange mounted motor IM3001, B5 (TEAO)

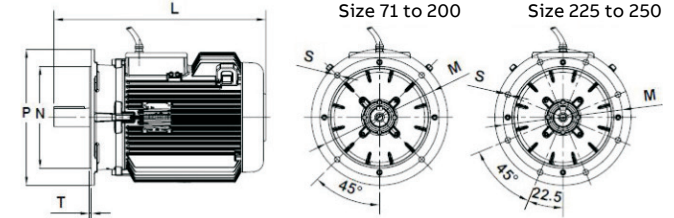

Foot-mounted motor IM1001, B3 (TEFC)

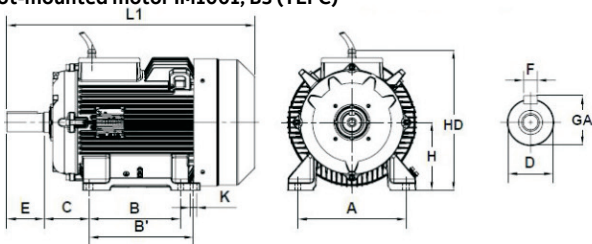

Flange mounted motor IM3001, B5 (TEFC)

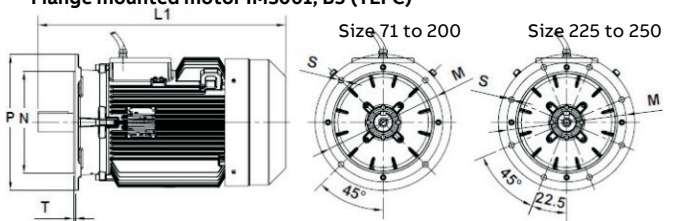

Motor size	L (TEAO)				L1 (TEFC)				HD												
	D	GA	F	E	IE2	IE3	IE2	IE3	A	B	B'	C	IE2	IE3	K	H	M	N	P	S	T
71M	14	16	5	30	-	222	-	257	112	90	-	45	175	7	71	130	110	160	10	3.5	
71ML	14	16	5	30	-	227	-	282	112	90	-	45	175	7	71	130	110	160	10	3.5	
80M	19	21.5	6	40	-	269	-	309	125	100	-	50	192	10	80	165	130	200	12	3.5	
80ML	19	21.5	6	40	-	294	-	334	125	100	112	50	192	10	80	165	130	200	12	3.5	
90S	24	27	8	50	-	292	-	335	140	100	-	56	217	10	90	165	130	200	12	3.5	
90SL	24	27	8	50	-	308	-	351	140	100	125	56	217	10	90	165	130	200	12	3.5	
90L	24	27	8	50	-	343	-	386	140	-	125	56	217	10	90	165	130	200	12	3.5	
100L	28	31	8	60	-	332	-	376	160	140	-	63	240	12	100	215	180	250	14.5	4	
100LK	28	31	8	60	-	366	-	410	160	140	160	63	240	12	100	215	180	250	14.5	4	
112M	28	31	8	60	367	-	411	-	190	140	-	70	252	12	112	215	180	250	14.5	4	
112ML	28	31	8	60	-	411	-	456	190	140	159	70	252	12	112	215	180	250	14.5	4	
132S	38	41	10	80	388	-	479	-	216	140	-	89	301	12	132	265	230	300	14.5	4	
132SM	38	41	10	80	-	430	-	521	216	140	178	89	301	12	132	265	230	300	14.5	4	
132ML	38	41	10	80	-	495	-	586	216	178	203	89	301	12	132	265	230	300	14.5	4	
160ML	42	45	12	110	522 <sup>1),1')</sup>	562 <sup>5)</sup>	586 <sup>1),1')</sup>	639 <sup>5)</sup>	254	210	254	108	365	14.5	160	300	250	350	19	5	
180ML	48	51.5	14	110	619 <sup>2)</sup>	642	683 <sup>2)</sup>	728	279	241	279	121	385	405	14.5	180	300	250	350	19	5
200ML	55	59	16	110	642 <sup>3)</sup>	695	728 <sup>3)</sup>	809	318	267	305	133	425	455	18.5	200	350	300	400	19	5
225SM 2P	55	59	16	110	735 <sup>4)</sup>	693	854 <sup>4)</sup>	812	356	286	311	149	480	500	18.5	225	400	350	450	19	5
225SM 4-8P	60	64	18	140	735 <sup>4)</sup>	723	854 <sup>4)</sup>	842	356	286	311	149	480	500	18.5	225	400	350	450	19	5
250SM 2P	60	64	18	140	747	776	882	853	406	311	349	168	525	553	24	250	500	450	550	19	5
250SM 4-8P	65	69	18	140	747	776	882	853	406	311	349	168	525	553	24	250	500	450	550	19	5

Above table gives the main dimensions in mm.

Frame size 71-132 flying leads outlet from side.

Ref.	Motor Size	L (TEAO)	L1 (TEFC)
1)	S2BAX160MLC2, B4, J6	562	626
1')	S2BAX160MLB6	582	646
2)	S2BAX180MLB4, A6	639	703
3)	S2BAX200MLB2, A4, B6	682	768
4)	S2BAX225SMB4, A6	765	884
5)	S3BAX160MLC2, B4, B6	590	696

## Motors in brief

Smoke extraction IE2, IE3 efficiency motors size 71-250

Size		71	80	90	100	112	132
<b>Stator</b>	Material	Cast Iron Grade 150:ISO 185					
	Paint colour shade	RAL 9007 (Grey Aluminium)					
	Corrosion class	C3 medium according to ISO/EN 12944-5					
<b>Feet</b>		Fixed feet					
	Material	Cast Iron Grade 150:ISO 185					
	Material	Cast Iron Grade 150:ISO 185					
<b>Bearing end shields</b>	Paint colour shade	RAL 9007 (Grey Aluminium)					
	Corrosion class	C3 medium according to ISO/EN 12944-5					
<b>Bearings</b>	D-end	6203-2Z/C3	6204-2Z/C3	6205-2Z/C3	6206-2Z/C3	6206-2Z/C3	6208-2Z/C3
	N-end	6202-2Z/C3	6203-2Z/C3	6204-2Z/C3	6205-2Z/C3	6205-2Z/C3	6208-2Z/C3
<b>Axially-locked</b>	Retaining Ring	<b>As standard, locked at D-end</b>					
<b>Bearing seals</b>		Axial seal as standard, radial on request					
<b>Lubrication</b>		Permanently lubricated shielded bearings					
<b>Measuring nipple</b>		Not included					
<b>Rating plate</b>	Material	Aluminium					
<b>Terminal Box</b>	Frame material	Cast Iron, Integral to stator frame					
	Cover material	Sheet of steel, Cold rolled					
	Cover screws material	Steel 8.8					
<b>Connections</b>	Terminals	Flying leads. Separate terminal box and plate as option					
	Cable gland	Suitable opening in terminal box, cable gland as an option					
<b>Fan</b>	Material	Without fan for TEAO. Metal fan for TEFC					
<b>Fan Cover</b>	Material	Without fan cover for TEAO. Sheet of Steel, cold rolled fan cover for TEFC.					
	Paint Colour shade	RAL 9007 (Grey Aluminium)					
	Surface Treatment	C3 medium according to ISO/EN 12944-5					
<b>Stator winding</b>	Material	Copper					
	Insulation	Insulation class H, Temperature rise class F, unless otherwise stated					
	Winding protection	VPI					
<b>Rotor winding</b>	Material	Pressure die cast Aluminium					
<b>Balancing method</b>		Half Key balancing as standard					
<b>Key ways</b>		Open Key Way					
<b>Enclosure</b>		IP 55					
<b>Cooling method</b>		IC 418 & IC 411.					

## Motors in brief

Smoke extraction IE2, IE3 efficiency motors size 71-250

Size		160	180	200	225	250
<b>Stator</b>	Material	Cast Iron Grade 200:ISO 185				
	Paint colour shade	RAL 9007 (Grey Aluminium)				
	Corrosion class	C3 medium according to ISO/EN 12944-5				
<b>Bearing end shields</b>	Material	Cast Iron Grade 200:ISO 185				
	Paint colour shade	RAL 9007 (Grey Aluminium)				
	Surface Treatment	C3 medium according to ISO / EN 12944-5				
<b>Bearings</b>	D-end	6209-2Z/C3	6310-2Z/C3	6312-2Z/C3	6313-2Z/C3	6315-2Z/C3
	N-end	6209-2Z/C3	6209-2Z/C3	6209-2Z/C3	6210-2Z/C3	6212-2Z/C3
<b>Axially-locked</b>	Inner Bearing Cover	As standard, locked at D-end				
<b>Bearing seals</b>		Axial seal standard, radial on request				
<b>Lubrication</b>		Permanently lubricated shielded bearings				
<b>Measuring nipple</b>		Not included				
<b>Rating plate</b>	Material	Aluminium				
<b>Terminal Box</b>	Box Material	Sheet of Steel, cold rolled				
	Cover material	Sheet of steel, Cold rolled				
	Cover screws material	Steel 8.8				
<b>Connections</b>	Terminals	Flying leads. Separate terminal box and plate as option				
	Cable gland	Suitable opening in terminal box, cable gland as an option				
<b>Fan</b>	Material	Without fan for TEAO. Metal fan for TEFC				
<b>Fan Cover</b>	Material	Without fan cover for TEAO. Sheet of Steel, cold rolled fan cover for TEFC				
	Paint Colour shade	RAL 9007 (Grey Aluminium)				
	Surface Treatment	C3 medium according to ISO/EN 12944-5				
<b>Stator winding</b>	Material	Copper				
	Insulation	Insulation class H, Temperature rise class F, unless otherwise stated				
	Winding protection	VPI				
<b>Rotor winding</b>	Material	Pressure die cast aluminium				
<b>Balancing method</b>		Half Key Balancing as Standard				
<b>Key ways</b>		Open Key Way				
<b>Enclosure</b>		IP 55				
<b>Cooling method</b>		IC 418 & IC 411				

# ABB Ability™ Smart Sensor

## Condition monitoring solution for low voltage motors

ABB Ability™ Smart Sensor is a condition monitoring solution that makes predictive maintenance possible for almost all low voltage motors. By monitoring and analyzing data on motor operating parameters, it enables motor users to optimize their maintenance. The solution helps to reduce downtime by as much as 70 percent, extend motor lifetimes by up to 30 percent and reduce energy consumption by up to 10%.

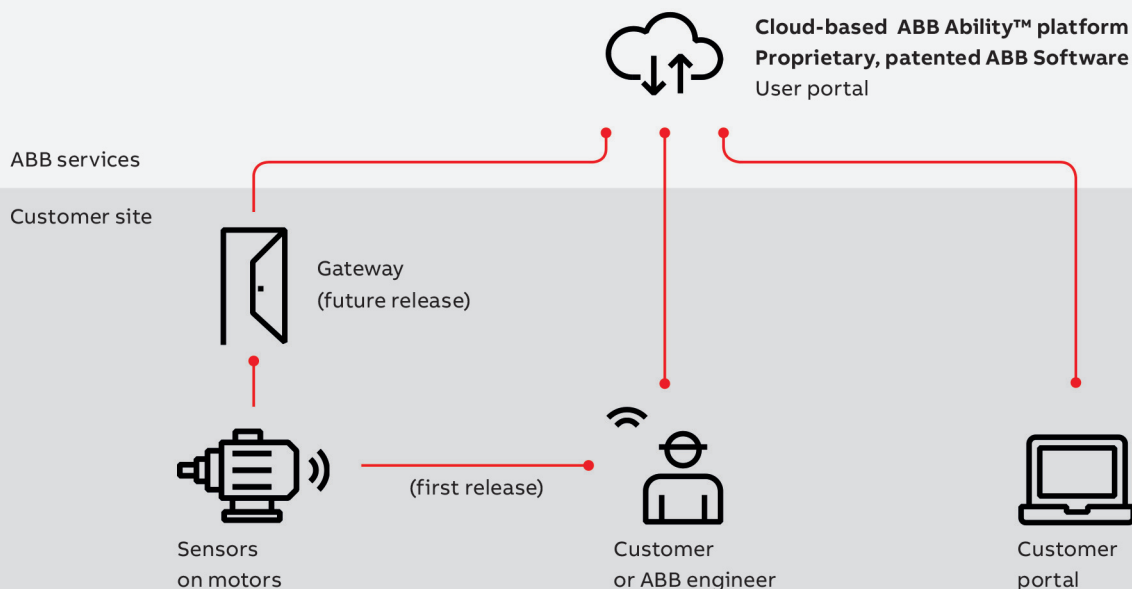

ABB's condition monitoring solution for LV motors. The ABB Ability™ Smart Sensor transmits data via a smartphone (first release) or gateway to a secure cloud service. Algorithms in the cloud analyze the data and convert it into meaningful information, which is then sent to the user's smartphone and customer portal.

For more information please visit:

[www.abb.com/smartsensor](http://www.abb.com/smartsensor)

or contact [contact.center@in.abb.com](mailto:contact.center@in.abb.com)



---

**ABB India Limited**

32, Industrial Area,  
N.I.T., Faridabad - 121 001  
Tel: +91 129 2448100

**[www.abb.co.in](http://www.abb.co.in)**

We reserve the right to make technical changes or modify the contents of this document without prior notice. With regard to purchase orders, the agreed particulars shall prevail. ABB does not accept any responsibility whatsoever for potential errors or possible lack of information in this document.

We reserve all rights in this document and in the subject matter and illustrations contained therein. Any reproduction, disclosure to third parties or utilization of its content - in whole or in parts - is forbidden without ABB's prior written consent.

