

IRB 260

The packing robot



The IRB 260 is designed and optimized primarily for packing applications. It is built to meet your reach and payload requirements whilst being small enough to fit into compact packing machines. Combined with ABB motion control and tracking performance, the robot is ideal in flexible packing systems.

Compact industrial packing robot

Designed for easy integration into packaging lines, the new machine has the ability to work close to base in order to minimize floor space. Low on weight and height, the IRB 260 fits easily into compact production cells. Speed, moreover, has been optimized for an 800x800x800 mm working envelope, making the new robot ideal for packing applications.

Running on 4-axes, it's not only dedicated to packing applications, but also ensures high throughput and flexible packing concepts. Like all ABB robots, IRB 260 can be combined with PickMaster, ABB's vision guided packaging software, and our IRC5 controller.

Accurate – consistent parts quality

The robot has best in class accuracy and superior ABB conveyor tracking performance resulting in excellent pick and place accuracy, both when working with fixed positions as well as on the fly.

Fast - short cycle times

Design, optimized for packing in combination with ABB unique motion control, ensures short cycle times.

Reliable - high production up time

The IRB 260 is based on IRB 2400, the world's most popular industrial robot, with a total of 14,000 installations.

Strong – maximized utilization

The robot is optimized for packing application and combines compactness and high speed with a 30 kg payload capacity.

Robust – harsh production environment

Durable in tough environments - offering a standard of IP67 protection.

Versatile – flexible integration and production

Low on weight and height, the robot easily fits into compact packing machines. With a work envelope optimized for packing applications, the robot becomes the natural choice for robot automation. The robot comes fully equipped with integrated air and signals all the way to the gripper. Combined with the ABB packaging software, PickMaster™, the robot is not only easy to integrate from a mechanical point of view but also extremely simple to program.

Specification

Robot version IRB	Reach (m)	Handling capacity (kg)	Load offset (mm)
IRB 260	1.56	30	300
Number of axes	4		
Protection	IP67		
Integrated signal supply	23 poles, 50V DC; 10 poles, 250V AC		
Integrated air supply	1/3 inch hose, max 8 bar		
Controller	IRC5 Single cabinet, IRC5 Dual Cabinet, IRC5 Panel Mounted		

Performance (according to ISO 9283)

	Position repeatability RP (mm)
IRB 260	0.1

Technical information

Physical

Dimensions robot base	723 x 600 mm
Total height	1493 mm
Robot weight	340 kg

Environment

Ambient temperature for robot unit	+5° C (41° F) to + 45° C (113° F)
Relative humidity	Max. 95%
Noise level	Max 70 dB (A)
Safety	Double circuits with supervisions, emergency stops and safety functions. 3-position enable device

Emission	EMC/EMI shielded
----------	------------------

Data and dimensions may be changed without notice.

IRB 260

Axis	Working range	Max velocity
Axis 1	+180° to -180°	153°/s
Axis 2	+85° to -28°	175°/s
Axis 3	+119° to -17°	153°/s
Axis 6	+400° to -400°	342°/s

IRB 260, working range

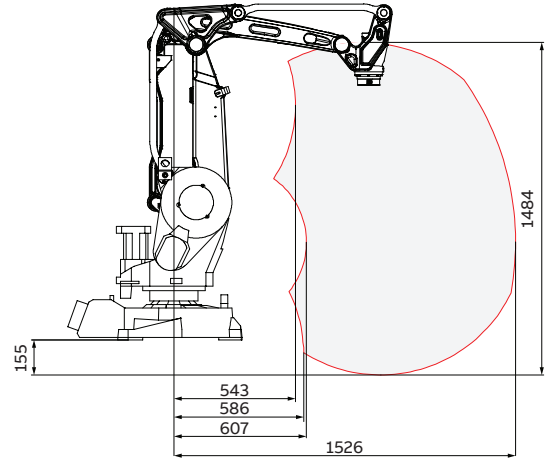

Park cycle

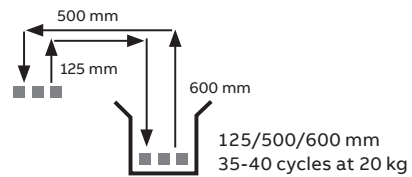

Park cycle

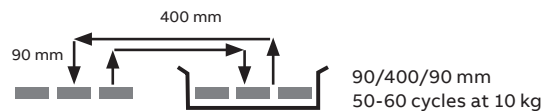

ABB AB Robotics
Hydrovägen 10 SE-721 36
Västerås, Sweden
Phone: +46 21325000

ABB Engineering (Shanghai) Ltd.
No. 4528, Kangxin Highway,
Pudong New District,
Shanghai, 201319, China
Phone: +86 21 6105 6666

We reserve the right to make technical changes or modify the contents of this document without prior notice. With regard to purchase orders, the agreed particulars shall prevail. ABB does not accept any responsibility whatsoever for potential errors or possible lack of information in this document.

We reserve all rights in this document and in the subject matter and illustrations contained therein. Any reproduction, disclosure to third parties or utilization of its contents – in whole or in parts – is forbidden without prior written consent of ABB. Copyright © 2018 ABB
All rights reserved