

Product Specification

IRB 6400R

3HAC 9040-1 / Rev 4
M2000



S4Cplus



140



2400



1400



840



4400



340



6400S



640



6400PE



6400R

The information in this document is subject to change without notice and should not be construed as a commitment by ABB Automation Technologies, Robotics. ABB Automation Technologies, Robotics assumes no responsibility for any errors that may appear in this document.

In no event shall ABB Automation Technologies, Robotics be liable for incidental or consequential damages arising from use of this document or of the software and hardware described in this document.

This document and parts thereof must not be reproduced or copied without ABB Automation Technologies, Robotics' written permission, and contents thereof must not be imparted to a third party nor be used for any unauthorized purpose. Contravention will be prosecuted.

Additional copies of this document may be obtained from ABB Automation Technologies, Robotics at its then current charge.

© Copyright 2001 ABB. All rights reserved.

Article number: 3HAC 9040-1/Rev. 4
Issue: M2000

ABB Automation Technologies
Robotics
SE-721 68 Västerås
Sweden

CONTENTS

	Page
1 Description	3
1.1 Structure.....	3
Different robot versions	4
Definition of version designation.....	4
1.2 Safety/Standards	6
1.3 Installation	8
Operating requirements.....	8
Mounting the manipulator.....	8
Load diagrams.....	10
Handling capacity for IRB 6400R /2.8-150 in press-tending application.....	13
Mounting equipment	15
Holes for mounting extra equipment	17
1.4 Maintenance and Troubleshooting	19
1.5 Robot Motion.....	20
Performance according to ISO 9283.....	21
Velocity	21
Resolution	21
1.6 Application Interface	22
Specification.....	22
1.7 Spotweld Base Harness and Spotweld Base Harness Extended.....	23
Specification.....	23
1.8 Upper Arm Harness	24
Specification.....	24
1.9 Dresspack examples	26
1.10 Servo Gun.....	27
2 Specification of Variants and Options	33
3 Accessories	43
4 Index	45

1 Description

1.1 Structure

IRB 6400R is a 6-axis industrial robot, designed specifically for manufacturing industries that use flexible robot-based automation. The robot has an open structure that is specially adapted for flexible use, and can communicate extensively with external systems.

The robots with Foundry protection are designed for harsh environment and have special surface treatment and paint for excellent corrosion protection. The connectors are designed for severe environment, and bearings, gears and other sensitive parts are high protected. The robots have the FoundryPlus protection which means that the whole manipulator is IP67 classified and steam washable.

The robot is equipped with the operating system BaseWare OS. BaseWare OS controls every aspect of the robot, like motion control, development and execution of application programs communication etc. See Product Specification S4Cplus.

For additional functionality, the robot can be equipped with optional software for application support - for example gluing and spot welding, communication features - network communication - and advanced functions such as multitasking, sensor control etc. For a complete description on optional software, see the Product Specification RobotWare Options.

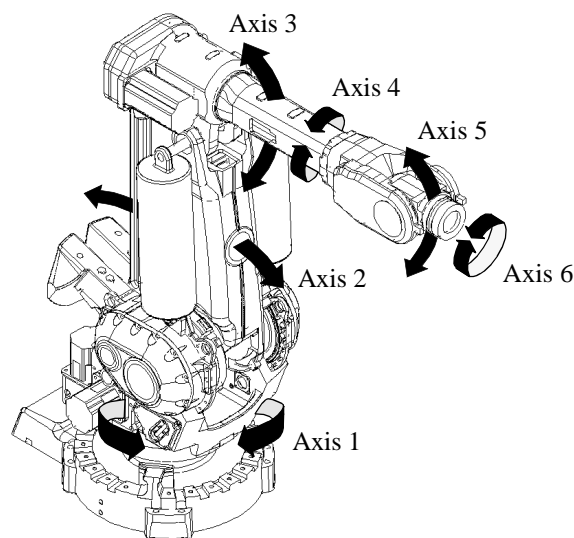

Figure 1 The IRB 6400R manipulator has 6 axes.

Description

Different robot versions

The IRB 6400R is available in several different versions. The following different robot types are available:

Standard:

IRB 6400R/2.5-120
IRB 6400R/2.5-150
IRB 6400R/2.5-200
IRB 6400R/2.8-150
IRB 6400R/2.8-200
IRB 6400R/3.0-100

Foundry:

IRB 6400RF/2.5-120
IRB 6400RF/2.5-150
IRB 6400RF/2.5-200
IRB 6400RF/2.8-150
IRB 6400RF/2.8-200
IRB 6400RF/3.0-100

Definition of version designation

IRB 6400R Mounting/ Reach - Handling capacity

	Prefix	Description
Mounting	-	Floor-mounted manipulator
Reach	x.x	Indicates the maximum reach at wrist centre (m)
Handling capacity	yyy	Indicates the maximum handling capacity (kg)
Application	F	Manipulator adapted for use in harsh environments (e.g. foundry)

Manipulator weight	IRB 6400R /2.5-120	2060 kg
	IRB 6400R /2.5-150	2060 kg
	IRB 6400R /2.5-200	2230 kg
	IRB 6400R /2.8-150	2240 kg
	IRB 6400R /2.8-200	2390 kg
	IRB 6400R /3.0-100	2250 kg

Airborne noise level:

The sound pressure level outside the working space < 70 dB (A) Leq (acc. to Machinery directive 98/37/EEC)

IRB 6400R /2.5-120, /2.5-150, /2.5-200, /2.8-150, /2.8-200 and /3.0-100

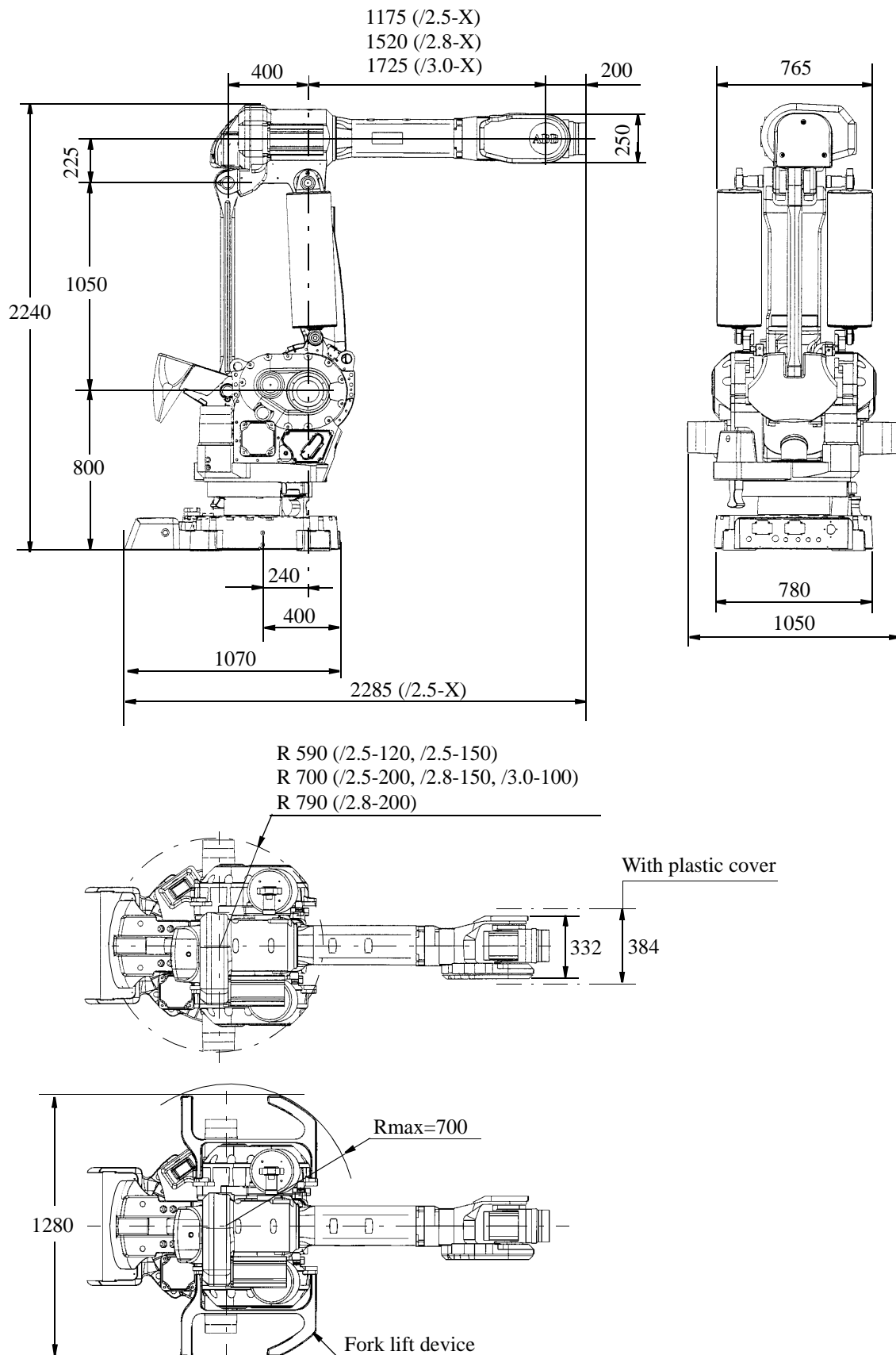

Figure 2 View of the manipulator from the side, rear and above (dimensions in mm).

1.2 Safety/Standards

The robot conforms to the following standards:

EN 292-1	Safety of machinery, terminology
EN 292-2	Safety of machinery, technical specifications
EN 954-1	Safety of machinery, safety related parts of control systems
EN 60204	Electrical equipment of industrial machines
IEC 204-1	Electrical equipment of industrial machines
ISO 10218, EN 775	Manipulating industrial robots, safety
ANSI/RIA 15.06/1999	Industrial robots, safety requirements
ISO 9409-1	Manipulating industrial robots, mechanical interface
ISO 9787	Manipulating industrial robots, coordinate systems and motions
IEC 529	Degrees of protection provided by enclosures
EN 50081-2	EMC, Generic emission
EN 50082-2	EMC, Generic immunity
ANSI/UL 1740-1996 (option)	Standard for Industrial Robots and Robotic Equipment
CAN/CSA Z 434-94 (option)	Industrial Robots and Robot Systems - General Safety Requirements

The robot complies fully with the health and safety standards specified in the EEC's Machinery Directives.

The robot is designed with absolute safety in mind. It has a dedicated safety system based on a two-channel circuit which is monitored continuously. If any component fails, the electrical power supplied to the motors shuts off and the brakes engage.

Safety category 3

Malfunction of a single component, such as a sticking relay, will be detected at the next MOTOR OFF/MOTOR ON operation. MOTOR ON is then prevented and the faulty section is indicated. This complies with category 3 of EN 954-1, Safety of machinery - safety related parts of control systems - Part 1.

Selecting the operating mode

The robot can be operated either manually or automatically. In manual mode, the robot can only be operated via the teach pendant, i.e. not by any external equipment.

Reduced speed

In manual mode, the speed is limited to a maximum of 250 mm/s (600 inch/min.). The speed limitation applies not only to the TCP (Tool Centre point), but to all parts of the robot. It is also possible to monitor the speed of equipment mounted on the robot.

Three position enabling device

The enabling device on the teach pendant must be used to move the robot when in

manual mode. The enabling device consists of a switch with three positions, meaning that all robot movements stop when either the enabling device is pushed fully in, or when it is released completely. This makes the robot safer to operate.

Safe manual movement

The robot is moved using a joystick instead of the operator having to look at the teach pendant to find the right key.

Over-speed protection

The speed of the robot is monitored by two independent computers.

Emergency stop

There is one emergency stop push button on the controller and another on the teach pendant. Additional emergency stop buttons can be connected to the robot's safety chain circuit.

Safeguarded space stop

The robot has a number of electrical inputs which can be used to connect external safety equipment, such as safety gates and light curtains. This allows the robot's safety functions to be activated both by peripheral equipment and by the robot itself.

Delayed safeguarded space stop

A delayed stop gives a smooth stop. The robot stops in the same way as at a normal program stop with no deviation from the programmed path. After approx. 1 second the power supplied to the motors shuts off.

Collision detection (option)

In case an unexpected mechanical disturbance like a collision, electrode stick etc appears, the robot will stop and slightly back off from its stop position.

Restricting the working space

The movement of each axis can be restricted using software limits.

There are safeguarded space stops for connection of limit switches to restrict the working space.

Axes 1-3 can also be restricted by means of mechanical stops.

Hold-to-run control

"Hold-to-run" means that you must depress the start button in order to move the robot. When the button is released the robot will stop. The hold-to-run function makes program testing safer.

Fire safety

Both the manipulator and control system comply with UL's (Underwriters Laboratory) tough requirements for fire safety.

Safety lamp (option)

As an option, the robot can be equipped with a safety lamp mounted on the manipulator. This is activated when the motors are in the MOTORS ON state.

1.3 Installation

All the versions of IRB 6400R are designed for floor mounting. Depending on the robot version an end effector of max. weight 100 to 200 kg, including payload, can be mounted on the mounting flange (axis 6). See Load diagrams on page 10.

Extra loads (valve packages, transformers) can be mounted on the upper arm. On all versions an extra load can also be mounted on the frame of axis 1. Holes for mounting extra equipment on page 17.

The working range of axes 1-3 can be limited by mechanical stops. Position switches can be supplied on axes 1-3 for position indication of the manipulator.

Operating requirements

Protection standards

Standard	Manipulator	IP54
	Wrist	IP55
Foundry	Manipulator	IP67
	Upper arm	IP67
	Wrist	IP67

Explosive environments

The robot must not be located or operated in an explosive environment.

Ambient temperature

Manipulator during operation	+5°C (41°F) to +50°C (122°F)
Complete robot during transportation and storage, for short periods (not exceeding 24 hours)	-25°C (13°F) to +55°C (131°F) up to +70°C (158°F)

Relative humidity

Complete robot during transportation and storage	Max. 95% at constant temperature
Complete robot during operation	Max. 95% at constant temperature

Mounting the manipulator

Maximum load in relation to the base coordinate system.

	Endurance load in operation	Max. load at emergency stop
Force xy	±14000 N	±38000 N
Force z	22000 ±8000 N	22000 ±19000 N
Torque xy	±34000 Nm	±61000 Nm
Torque z	±7000 Nm	±15000 Nm

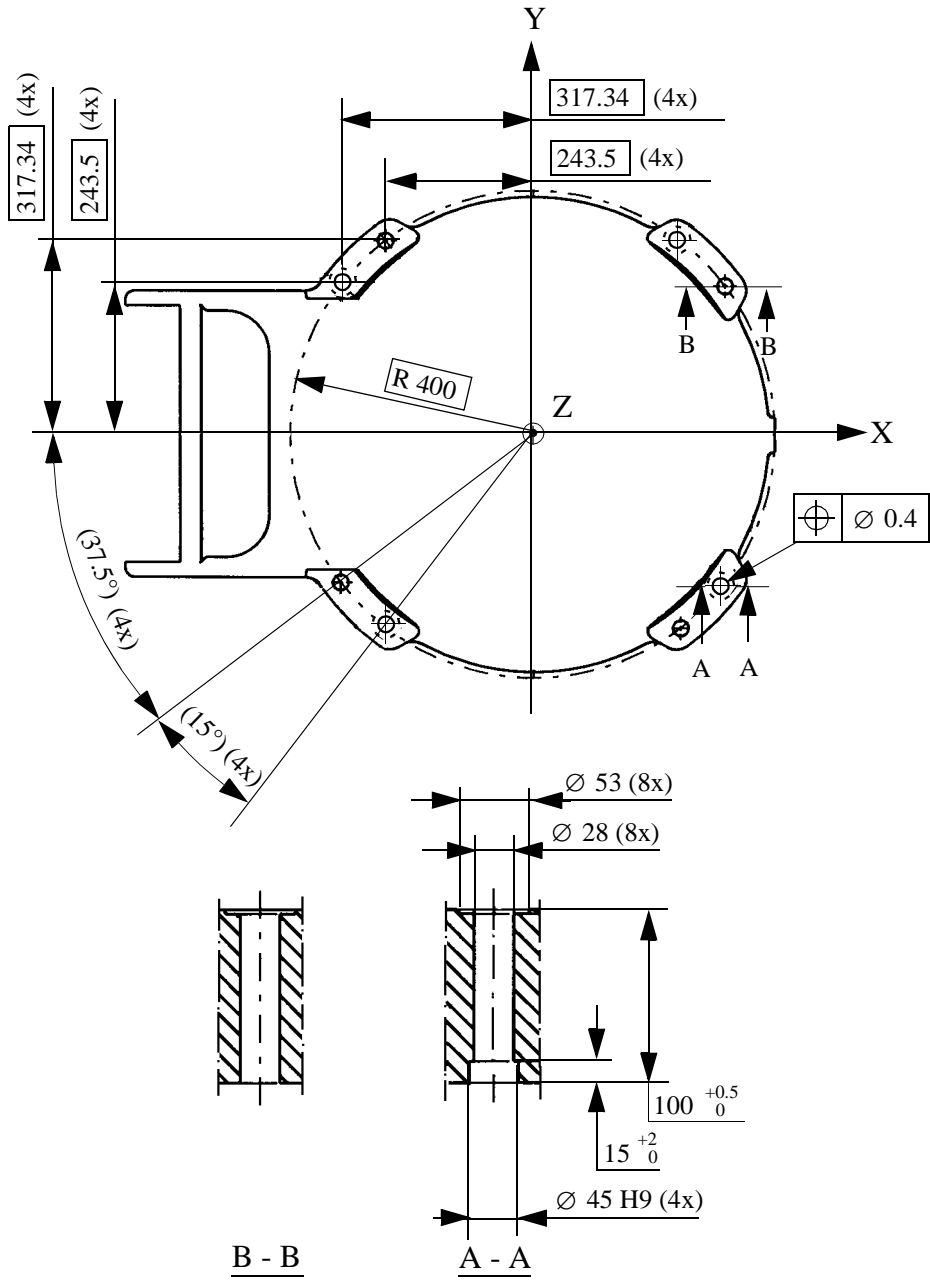

Figure 3 Hole configuration (dimensions in mm).

Description

Load diagrams

Load diagram for **IRB 6400R /2.5-120 and /3.0-100**

(The curve for 120 kg is not valid for /3.0-100, max. handling capacity limited to 100 kg).

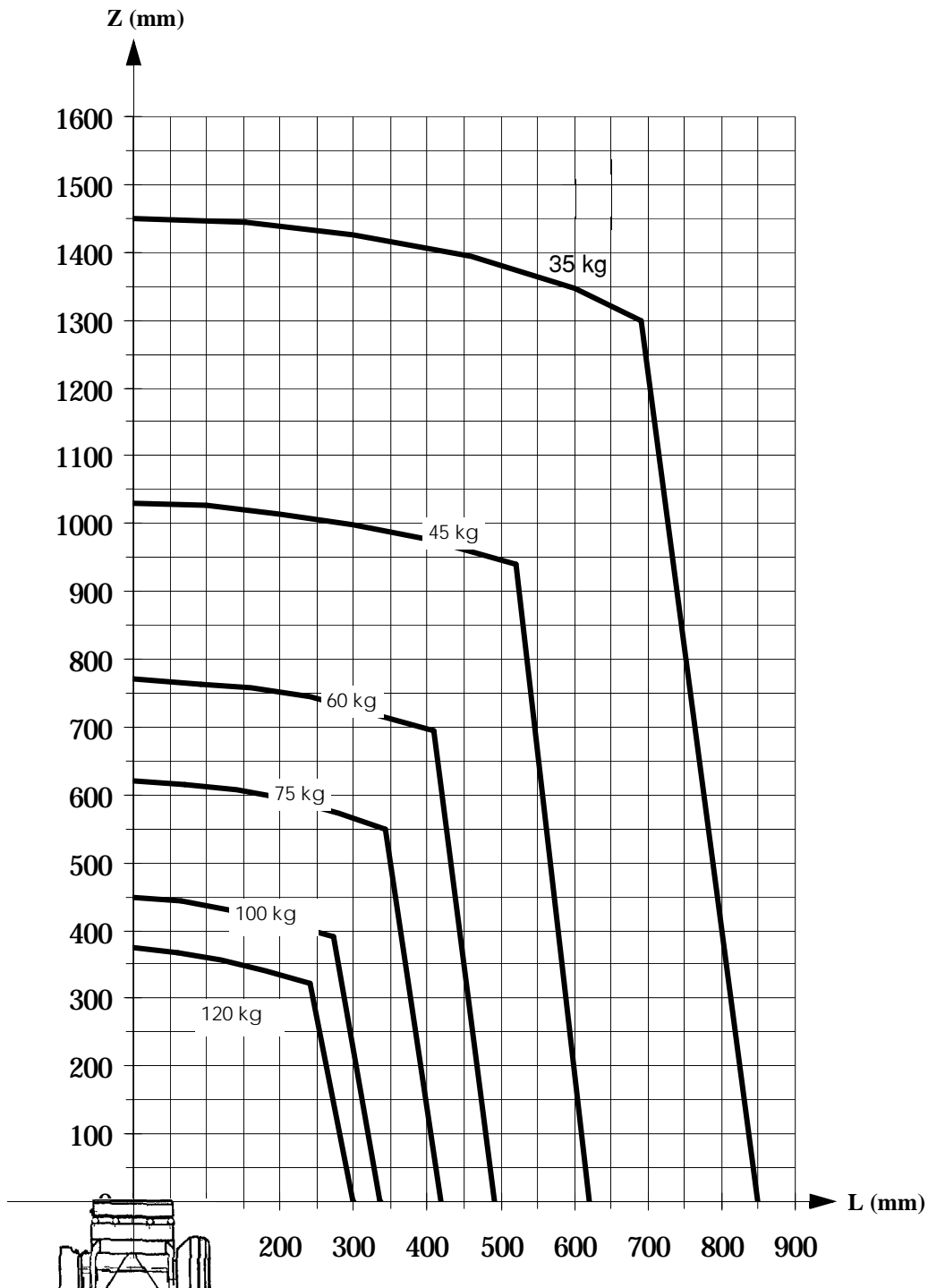

The load diagram is valid for $J_0 < 100 \text{ kgm}^2$.

J_0 = the maximum component (J_{X0} , J_{Y0} , J_{Z0}) of the moment of inertia of the handling weight at its centre of gravity.

Figure 4 Maximum weight permitted for load mounted on the mounting flange at different positions (centre of gravity).

Load diagram for IRB 6400R /2.5-150 and /2.8-150

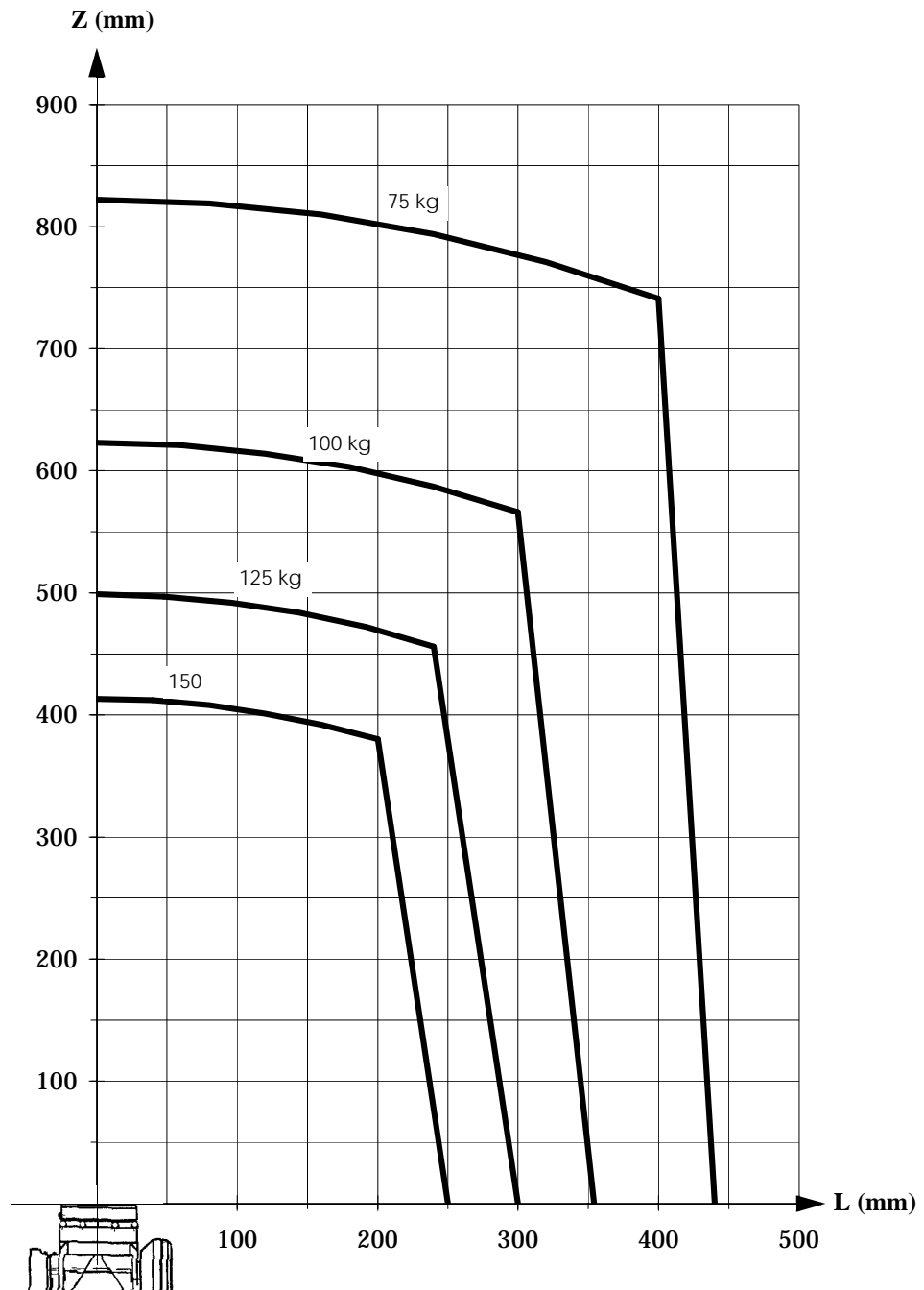

The load diagram is valid for $J_0 < 100 \text{ kgm}^2$.
 J_0 = the maximum component (J_{X0} , J_{Y0} , J_{Z0}) of the moment of inertia of the handling weight at its centre of gravity.

Figure 5 Maximum weight permitted for load mounted on the mounting flange at different positions (centre of gravity).

Description

Load diagram for IRB 6400R /2.5-200 and /2.8-200

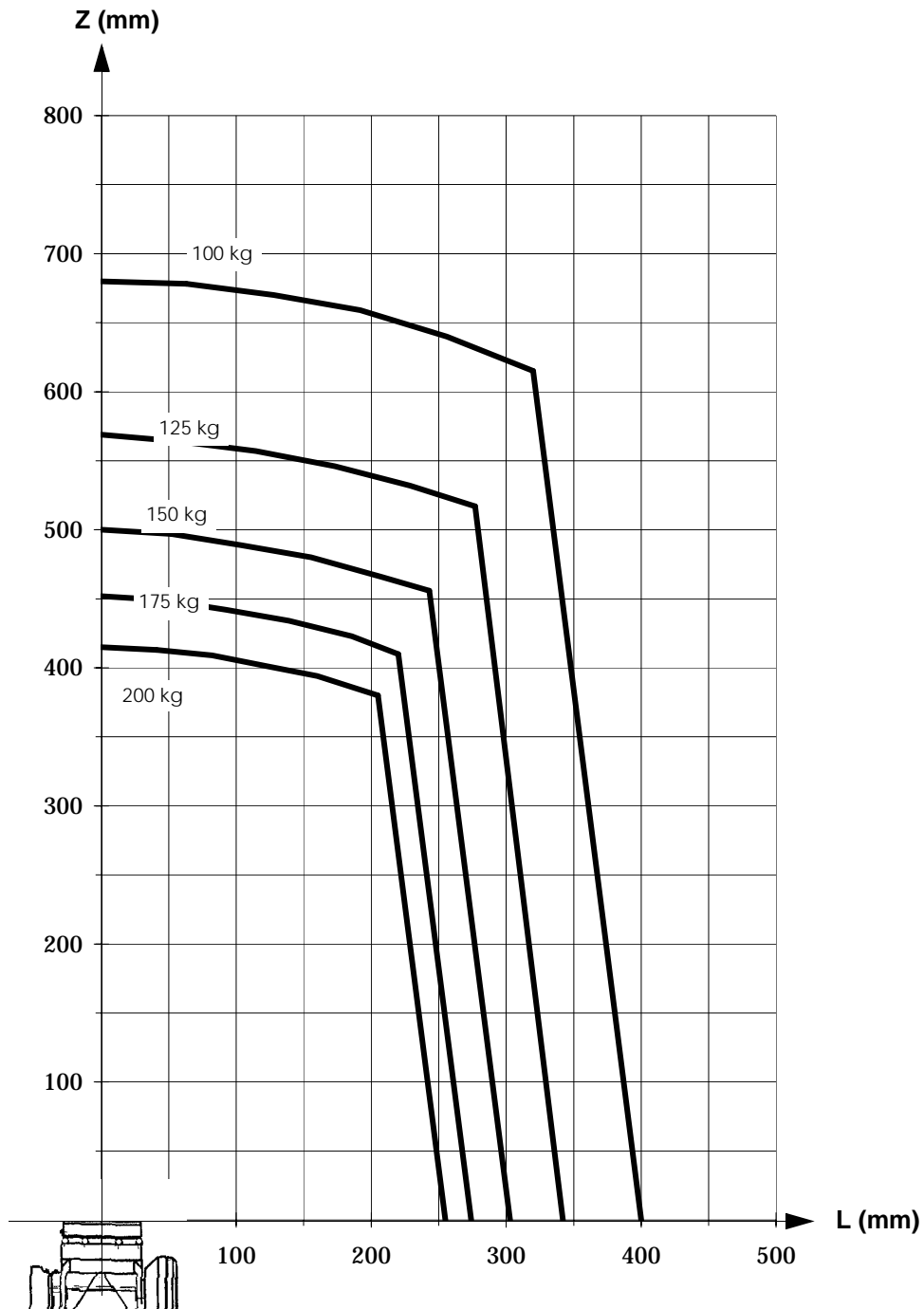

The load diagram is valid for $J_0 < 100 \text{ kgm}^2$.
 J_0 = the maximum component (J_{X0} , J_{Y0} , J_{Z0}) of the moment of inertia of the handling weight at its centre of gravity.

Figure 6 Maximum weight permitted for load mounted on the mounting flange at different positions (centre of gravity).

Handling capacity for IRB 6400R /2.8-150 in press-tending application

Note! Option 84-1, Cooling for axis 1 motor, must be installed.

The weight and dimensions of the part and gripper are limited by the maximum static torque and moment of inertia.

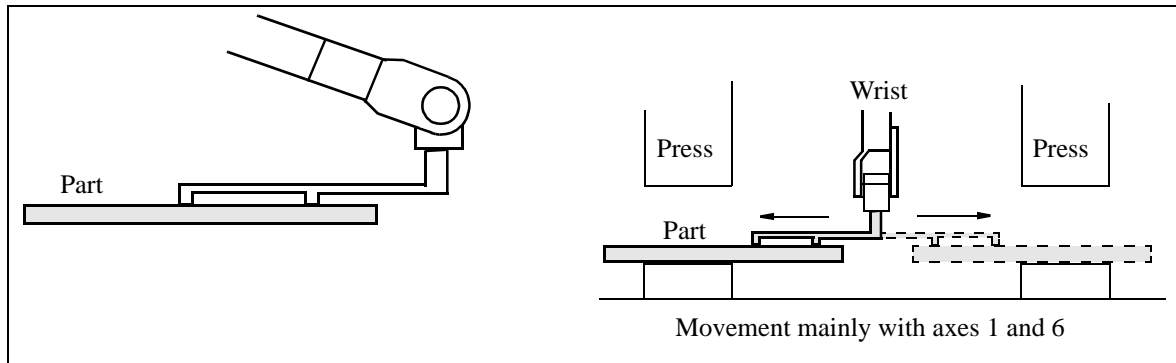

Figure 7 A-movement (inward movement).

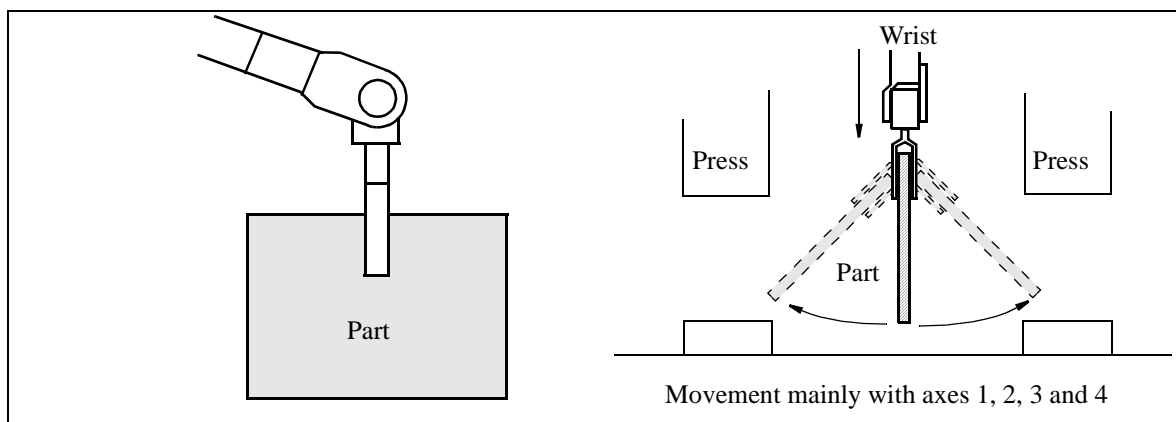

Figure 8 B-movement.

Static torque:	A-movement	Axis 5 $Ma_5 < 900 \text{ Nm}$
	B-movement	Axis 4 $Mb_4 < 900 \text{ Nm}$
Moment of inertia:	A-movement	Axis 5, $Ja_5 < 105 \text{ kgm}^2$
		Axis 6, $Ja_6 < 120 \text{ kgm}^2$
	B-movement	Axis 4, $Jb_4 < 105 \text{ kgm}^2$
		Axis 5, $Jb_5 < 120 \text{ kgm}^2$

Approximations of M and J can be calculated using the following formula:

$$Ma_5 = 9.81 \cdot (m_g \cdot r + m_p \cdot s) \quad (\text{Nm})$$

$$Mb_4 = 9.81 \cdot (m_g \cdot (r + 0.2) + m_p \cdot (s + 0.2)) \quad (\text{Nm})$$

$$Ja_5 = m_g / 12 \cdot c^2 + m_g \cdot r^2 + m_p / 12 \cdot a^2 + m_p \cdot s^2 \quad (\text{kgm}^2)$$

$$Ja_6 = m_g / 12 \cdot c^2 + m_g \cdot r^2 + m_p / 12 \cdot (a^2 + b^2) + m_p \cdot s^2 \quad (\text{kgm}^2)$$

$$Jb_4 = m_g / 12 \cdot c^2 + m_g \cdot (r + 0.2)^2 + m_p / 12 \cdot a^2 + m_p \cdot (s + 0.2)^2 \quad (\text{kgm}^2)$$

$$Jb_5 = m_g / 12 \cdot c^2 + m_g \cdot (r + 0.2)^2 + m_p / 12 \cdot (a^2 + b^2) + m_p \cdot (s + 0.2)^2 \quad (\text{kgm}^2)$$

m_g = weight of gripper (kg) m_p = weight of part (kg)

Distances a, b, c, r and s (m) are shown in Figure 9.

Description

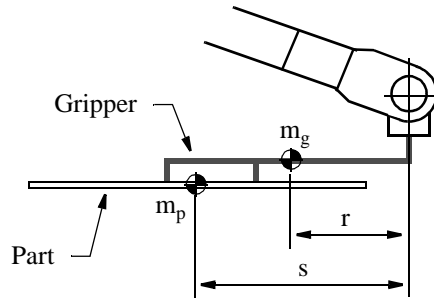

A-movement, gripper perpendicular to axis 6

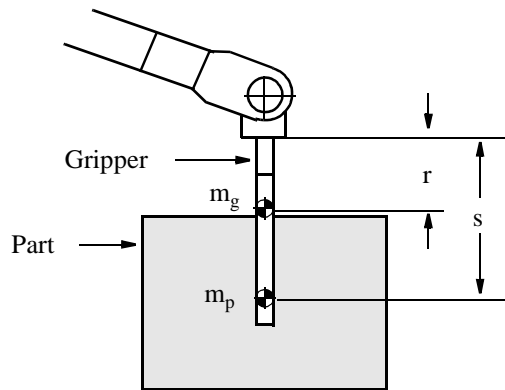

B-movement, gripper parallel to axis 6

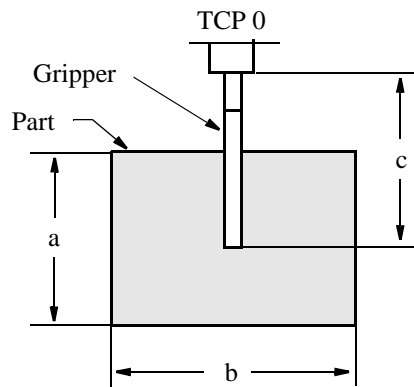

Dimensions of gripper and part

Figure 9 Distances r and s (m).

Mounting equipment

Extra loads can be mounted on the upper arm and the frame. Definitions of distances and masses are shown in Figure 10 and Figure 11.

The robot is supplied with holes for mounting extra equipment (see Figure 12).

Upper arm - Balancing unit type A

IRB 6400R /2.5-120, /2.5-150, /2.5-200, /2.8-150 and /2.8-200

Permitted extra load on upper arm plus the maximum handling weight (See Figure 10):

M1 ≤50 kg with distance a ≤500 mm, centre of gravity in axis 3 extension
or

M2 ≤50 kg with distance b ≤400 mm

or

M3 ≤15 kg with distance c ≥300 mm

If the handling weight is lower than the maximum weight, M1 alt. M2 can be increased as follows:

$(M1 \text{ alt. } M2 + \text{handling weight}) \leq (50 \text{ kg} + \text{max. handling weight})$.

For example, if the handling weight for 2.5-150 is only 120 kg, M2 can be 80 kg.

IRB 6400R /3.0-100

Permitted extra load on upper arm (See Figure 10):

M1 ≤50 kg with distance a ≤500 mm, centre of gravity in axis 3 extension
or

M2 ≤20 kg with distance b ≤400 mm

or

M3 ≤5 kg with distance c ≥300 mm

Upper arm - Balancing unit type B

IRB 6400R /2.5-120, /2.5-150, /2.5-200 and /2.8-150

Permitted extra load on upper arm plus the maximum handling weight (See Figure 10):

M1 ≤70-155 kg with distance a ≤ 500 mm, centre of gravity in axis 3 extension, see Note 1.

or

M2 ≤50 kg with distance b ≤400 mm, see Note 1.

or

M3 ≤15 kg with distance c ≥300 mm, see Note 1.

If the handling weight is lower than the maximum weight, M1 alt. M2 can be increased as follows:

$(M1 + \text{handling weight}) \leq (155 \text{ kg} + \text{max. handling weight})$.

$(M2 + \text{handling weight}) \leq (50 \text{ kg} + \text{max. handling weight})$.

For example, if the handling weight for 2.5-150 is only 120 kg, M2 can be 80 kg.

Note 1. Handling weight + extra load on upper arm must always be >70kg

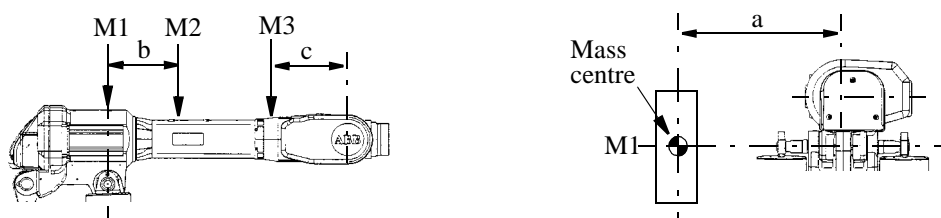

Figure 10 Permitted extra load on upper arm.

Description

Frame (Hip Load)

Permitted extra load on frame is $J_H = 120 \text{ kgm}^2$.

Recommended position (see Figure 11).

$$J_H = J_{H0} + M4 \cdot R^2$$

where J_{H0} is the moment of inertia of the equipment
 R is the radius (m) from the centre of axis 1
 $M4$ is the total mass (kg) of the equipment including bracket and harness ($\leq 320 \text{ kg}$)

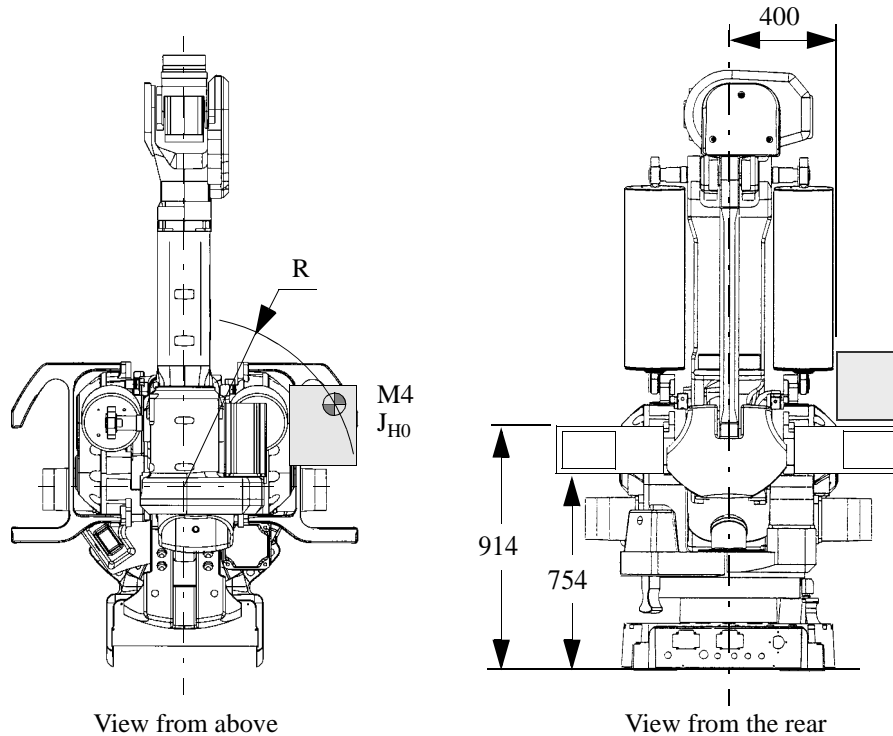

Figure 11 Extra load on frame of IRB 6400R (dimensions in mm).

Mounting of hip load

The extra load can be mounted either on the fork lift device or on the frame. Holes for mounting see Figure 13.

When mounting on the frame all the six holes (2x3, $\varnothing 18$) on one side must be used.

Holes for mounting extra equipment

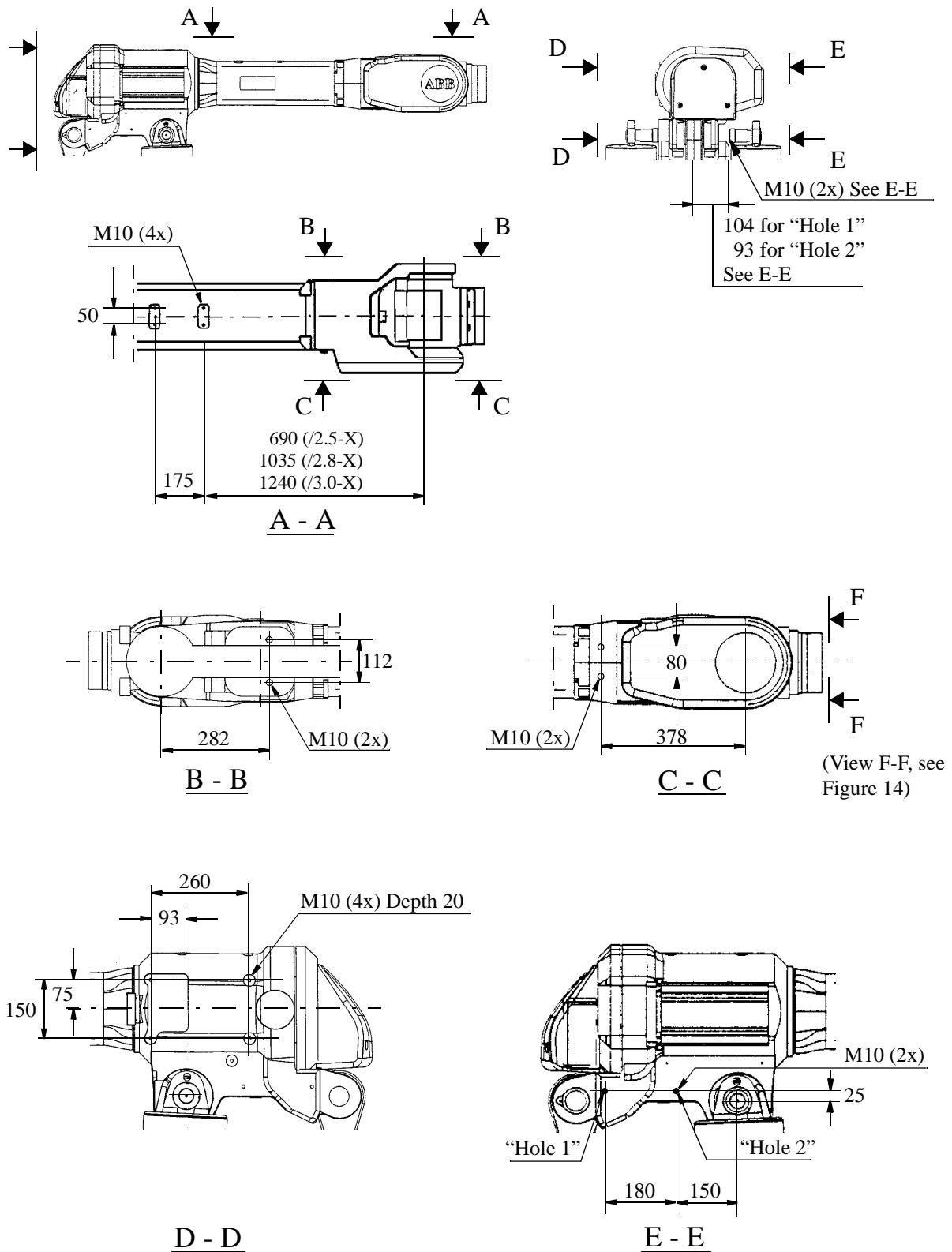

Figure 12 Holes for mounting extra equipment on the upper arm (dimensions in mm).

Description

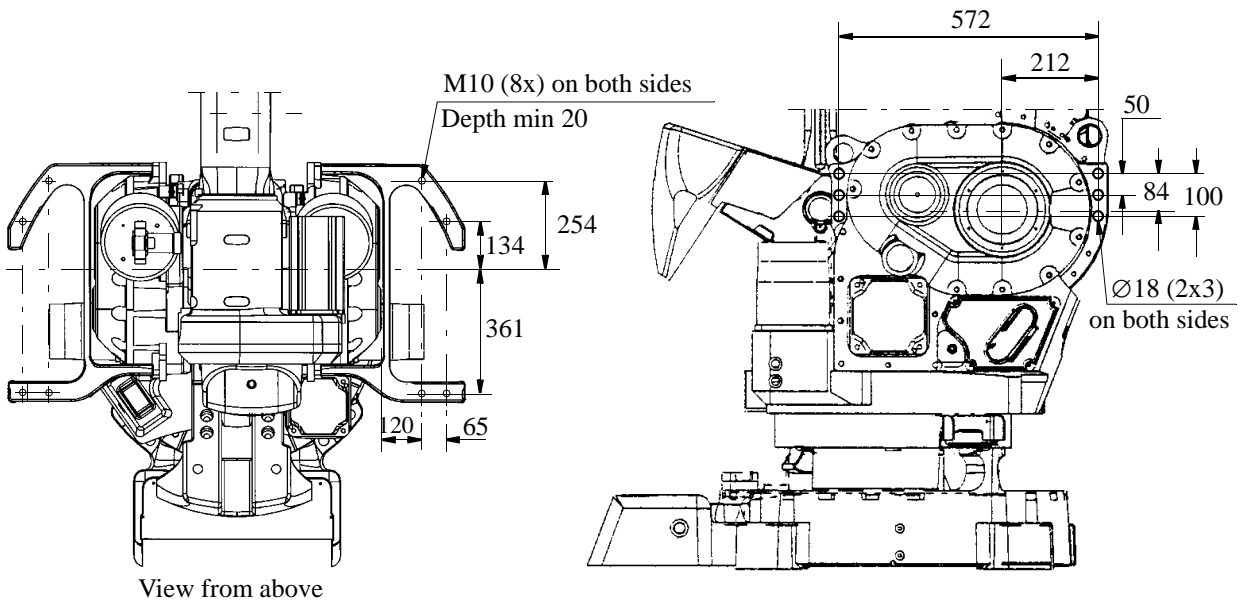

Figure 13 Holes for mounting of extra load on the fork lift device and the frame (dimensions in mm).

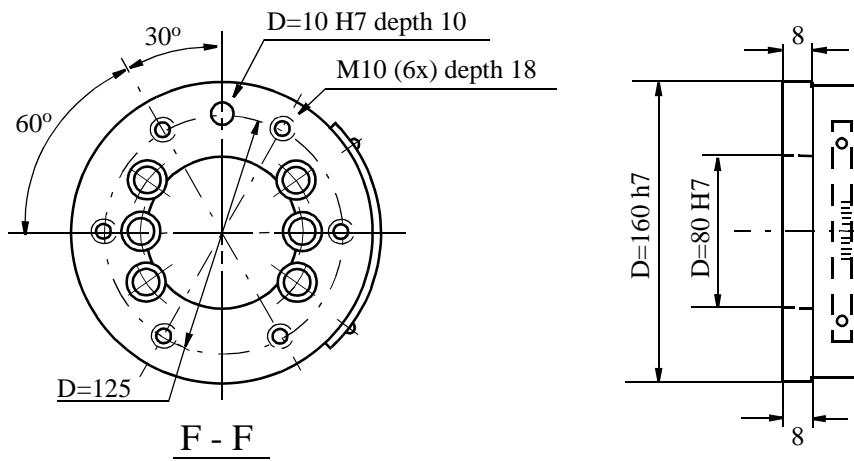

Figure 14 The mechanical interface (mounting flange) ISO 9409-1-A125 (dimensions in mm).

As an option there is an electrically insulated tool flange.
For more information see page 40 and Figure 28.

1.4 Maintenance and Troubleshooting

The robot requires only a minimum of maintenance during operation. It has been designed to make it as easy to service as possible:

- Maintenance-free AC motors are used.
- Liquid grease or oil is used for the gear boxes.
- The cabling is routed for longevity, and in the unlikely event of a failure, its modular design makes it easy to change.

The following maintenance is required:

- Changing filter for the transformer/drive unit cooling every year.
- Changing batteries every third year.

The maintenance intervals depends on the use of the robot. For detailed information on maintenance procedures, see Maintenance section in the Product Manual.

1.5 Robot Motion

Type of motion	Range of movement
Axis 1 Rotation motion	+180° to -180°
Axis 2 Arm motion	+85° to -70°
Axis 3 Arm motion	+110° to -28°
Axis 4 Wrist motion	+300° to -300°
Axis 5 Bend motion	+120° to -120°
Axis 6 Turn motion	+300° to -300°

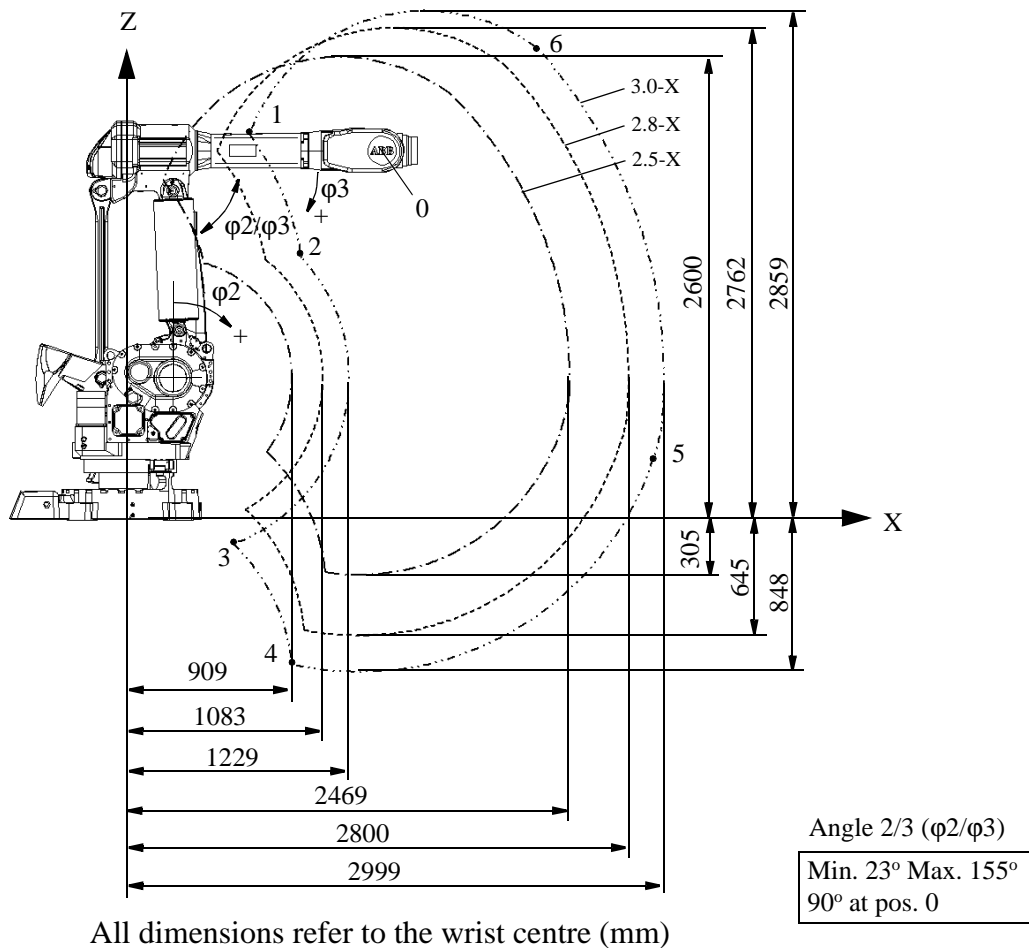

All dimensions refer to the wrist centre (mm)

Positions at wrist centre (mm)

Pos.	2.5		2.8-150 -200		3.0-100	
	-120	-150 -200	x	z	x	z
0	1415	2075	1760	2075	1965	2075
1	185	1909	490	2071	671	2168
2	415	1445	760	1463	964	1474
3	766	387	648	63	578	-130
4	1096	-290	978	-614	908	-806
5	2467	701	2791	583	2984	513
6	1804	2389	2108	2551	2289	2647

Angle φ2, φ3 (degrees)

pos.	axis 2 (φ2)	axis 3 (φ3)
0	0	0
1	-70	-28
2	-70	-3
3	43	110
4	85	110
5	85	20
6	37	-28

Figure 15 The extreme positions of the robot arm

Performance according to ISO 9283

At rated load and 1 m/s velocity on the inclined ISO test plane with all six robot axes in motion.

Unidirectional pose repeatability:

RP = 0.1 mm

Linear path accuracy:

AT = 1.6 - 2.1 mm

Linear path repeatability:

RT = 0.4 - 0.6 mm (IRB 6400R/2.5-120, 2.5-150, 2.8-150)

RT = 0.8 - 1.0 mm (Others)

Minimum positioning time, to within 0.4 mm of the position:

0.2 - 0.25 sec. (IRB 6400R/2.5-120, 2.5-150 on 35 mm linear path)

0.5 - 0.6 sec. (IRB 6400R/2.5-120, 2.5-150 on 350 mm linear path)

0.25 - 0.35 sec. (Others, on 35 mm linear path)

0.6 - 0.7 sec. (Others, on 350 mm linear path)

The above values are the range of average test-results from a number of robots. If guaranteed values are required, please contact your nearest ABB office.

Velocity

IRB 6400R versions: 2.5-120 2.5-150 2.8-200
 3.0-100 2.5-200
 2.8-150

Axis no.

1	110°/s	100°/s	90°/s
2	100°/s	90°/s	70°/s
3	100°/s	90°/s	70°/s
4	210°/s	120°/s	110°/s
5	150°/s	120°/s	110°/s
6	210°/s	190°/s	110°/s

There is a supervision function to prevent overheating in applications with intensive and frequent movements.

Resolution

Approx. 0.01° on each axis.

1.6 Application Interface

The robot can be supplied with integrated power, signals, customer buses, servo signals and air hose to the upper arm housing (options 218-8, 218-4 and 141-2/141-1) or power, signals, customer buses and air hose to the upper arm axis 4 (option 218-6).

Specification

Standard signals at upper arm housing and upper arm axis 4 (options 218-8 and 218-6)

Table 1

Type	Pcs	Area	Allowed capacity
Power (CP)	2 + 1 earth	1,0 mm ²	250 V AC, 8 A
Signals (CS)	10	0,24 mm ² (AWG 24)	50 V AC/DC, 250 mA
Cust.Bus* Power	2	0,24 mm ² (AWG 24)	50 V AC/DC, 2 A
Cust.Bus* Signals	4 + 1 shield**	0,24 mm ² (AWG 24)	50 V AC/DC, 250 mA
Air (CAIR)	1	13 mm inner dia.***	Max 10 bar

* CAN/DeviceNet or Profibus

** Only 2+1 shield are used for CAN/DeviceNet and Profibus

*** G1/2" - 14 outer thread

Servo Gun cabling (option 218-4)

Table 2

Type	Pcs	Area	Allowed capacity
Servo signals (CFB)	8	0,24 mm ² (AWG 24)	50 V AC/DC, 250 mA
Servo Power (CMP)	6 + 2 earth 4	1,5 mm ² 0,5 mm ²	250 V AC, 10 A* 250 V AC, 5 A

* Each phase RMS = 20 A, max. peak 26 A

Extended signals (options 141-2 or 141-1)

Table 3

Type	Pcs	Area	Allowed capacity
Power (CP)	4 + 2 earth	0,5 mm ²	250 V AC, 5 A
Signals (CS)	19	0,24 mm ² (AWG 24)	50 V AC/DC, 250 mA
Customer Bus*	8	0,24 mm ² (AWG 24)	50 V AC/DC, 250 mA
Air (CAIR)	1	13 mm inner dia.**	Max. 10 bar

* CAN/DeviceNet or Profibus

** M22 x 1,5 outer thread

1.7 Spotweld Base Harness and Spotweld Base Harness Extended

The robot can be supplied with an integrated spotweld base harness (option 359-1), or an integrated spotweld base harness extended (option 361-1).

The integrated spotweld base harness (hose fittings: G1/2"-14 outer thread) or the integrated spotweld base harness extended (hose fittings: M22 x 1,5 outer thread) is used to supply primary current and cooling water to the upper arm. Connections at the manipulator base and at the upper arm housing. For more information, see Figure 23 and Figure 24.

Specification

Spotweld base harness (option 359-1)

Table 4

Type	Pcs	Area	Allowed capacity
Power (WELD)	2 + 1 earth	25 mm ²	Max. aver. curr. 135 A*
Process (PROC 1-3)	3	13 mm inner dia.**	Max. 10 bar

- * at +20°C ambient temperature and 100 A at +50°C ambient temperature.
 Max. current 2,5 kA/1s, (short-circuit current) 1,5 kA/3s.
 Max. voltage 600 V, frequency 50-1000 Hz.
 ** G1/2" - 14 outer thread.

Spotweld base harness extended (option 361-1)

Table 5

Type	Pcs	Area	Allowed capacity
Power (WELD)	2 + 1 earth	25 mm ²	Max. aver. curr. 135 A*
Process (PROC 1-3)	3	13 mm inner dia.**	Max. 10 bar

- * at +20°C ambient temperature and 100 A at +50°C ambient temperature.
 Max. current 2,5 kA/1s, (short-circuit current) 1,5 kA/3s.
 Max. voltage 600 V, frequency 50-1000 Hz.
 ** M22 x 1,5 outer thread.

1.8 Upper Arm Harness

The upper arm harness is available for material handling (MH) application (for 2,5, 2,8 and 3,0 m manipulator) and spotwelding (SW) application (for 2,5 and 2,8 m manipulator).

The upper arm harness for material handling is available in two different variants:

- MH Standard (option 223-1)
- MH Extended (option 222-1)

The upper arm harness for spotwelding is available in four different variants:

- SW Pneumatic Standard (option 364-1)
- SW Pneumatic Extended (option 451-1)
- SW Servo Standard (option 366-1)
- SW Servo Extended (option 365-1)

Specification

MH Standard (option 223-1)

Table 6

Type	Pcs	Area	Allowed capacity
Power (CP)	2 + 1 earth	1,0 mm ²	250 V AC, 8 A
Signals (CS)	10	1,0 mm ²	50 V AC/DC, 250 mA*
Air (CAIR)	1	12,5 mm inner dia.**	Max 10 bar

* Max. allowed current due to less area in cables between base to axis 3.

** G1/2" - 14 outer thread.

MH Extended (option 222-1)

Table 7

Type	Pcs	Area	Allowed capacity
Power (CP)	6	1,0 mm ²	250 V AC, 5 A*
Signals (CS)	18 + 1 shield	1,0 mm ²	50 V AC/DC, 250 mA*
Air (CAIR)	1	12,5 mm inner dia.**	Max 10 bar

* Max. allowed current due to less area in cables between base to axis 3.

** M22 x 1,5 mm outer thread.

SW Pneumatic Standard (option 364-1)

Table 8

Type	Pcs	Area	Allowed capacity
Weld (WELD)	2 + 1 earth	25 mm ²	Max. aver. curr. 135 A***
Power (CP)	2 + 1 earth	1,0 mm ²	250 V AC, 8 A
Signals (CS)	10	1,0 mm ²	50 V AC/DC, 250 mA*
Air (CAIR)	1	12,5 mm inner dia.**	Max 10 bar
Process (PROC 1-3)	3	12,5 mm inner dia.**	Max 10 bar

* Max. allowed current due to less area in cables between base to axis 3.

** G1/2" - 14 outer thread.

*** At +20°C ambient temperature and 100 A at +50°C ambient temperature.
Max. current 2,5 kA/1s, (short-circuit current) 1,5 kA/3s.
Max. voltage 600 V, frequency 50-1000 Hz.

SW Servo Standard (option 366-1)

Additional to "SW Pneumatic Standard" (option 364-1)

Table 9

Type	Pcs	Area	Allowed capacity
Servo signals (CFB)	6	0,5 mm ²	50 V AC/DC, 250 mA*
Servo power (CMP)	10 +2 earth	1,0 mm ²	6+2 earth 250 V AC, 7 A** 4 250 V AC, 5 A

* Max. allowed current due to less area in cables between base to axis 3.

** Each phase RMS = 20 A

SW Pneumatic Extended (option 451-1)

Table 10

Type	Pcs	Area	Allowed capacity
Weld (WELD)	2 + 1 earth	25 mm ²	Max. aver. curr. 135 A***
Power (CP)	4 + 2earth	1,0 mm ²	250 V AC, 5 A
Signals (CS)	19	1,0 mm ²	50 V AC/DC, 250 mA*
Air (CAIR)	1	12,5 mm inner dia.**	Max 10 bar
Process (PROC 1-3)	3	12,5 mm inner dia.**	Max 10 bar

* Max. allowed current due to less area in cables between base to axis 3.

** M22 x 1,5 outer thread.

*** At +20°C ambient temperature and 100 A at +50°C ambient temperature.
Max. current 2,5 kA/1s, (short-circuit current) 1,5 kA/3s.
Max. voltage 600 V, frequency 50-1000 Hz.

Description

SW Servo Extended (option 365-1)

Additional to “SW Pneumatic Extended” (option 451-1)

Table 11

Type	Pcs	Area	Allowed capacity
Servo signals (CFB)	6	0,5 mm ²	50 V AC/DC, 250 mA*
Servo power (CMP)	10 +2 earth	1,0 mm ²	6+2 earth 250 V AC, 7 A** 4 250 V AC, 5 A

* Max. allowed current due to less area in cables between base to axis 3.

** Each phase RMS = 14 , max. peak 26 AA

1.9 Dresspack examples

The tables below (12-13) are examples showing which options are included in typical Dresspack solutions.

Table 12

Dresspack Option for	MH Standard	SW Pneumatic Standard	SW Servo Standard
Total IRB	16-2 or 16-1	16-2 or 16-1	16-2 or 16-1 + 93-1--4
Axes 1-3	218-8	218-8 + 359-1	218-8 + 359-1 + 218-4
Axes 3-6	223-1	364-1	366-1

Table 13

Dresspack Option for	MH Extended	SW Pneumatic Extended	SW Servo Extended
Total IRB	141-2 or 141-1	141-2 or 141-1	141-2 or 141-1 + 93-1--4
Axes 1-3	141-2 or 141-1	141-2/141-1 + 361-1	141-2 or 141-1 + 361-1 + 218-4
Axes 3-6	222-1	451-1	365-1

1.10 Servo Gun

The robot can be supplied with hardware and software for Stationary Gun, Robot Gun, Stationary and Robot Gun, Twin Stationary Guns, Stationary Gun and Track Motion or Robot Gun and Track Motion.

For configuration and specification of hardware and software respectively, see each section below.

1.10.1 Stationary Gun (SG)

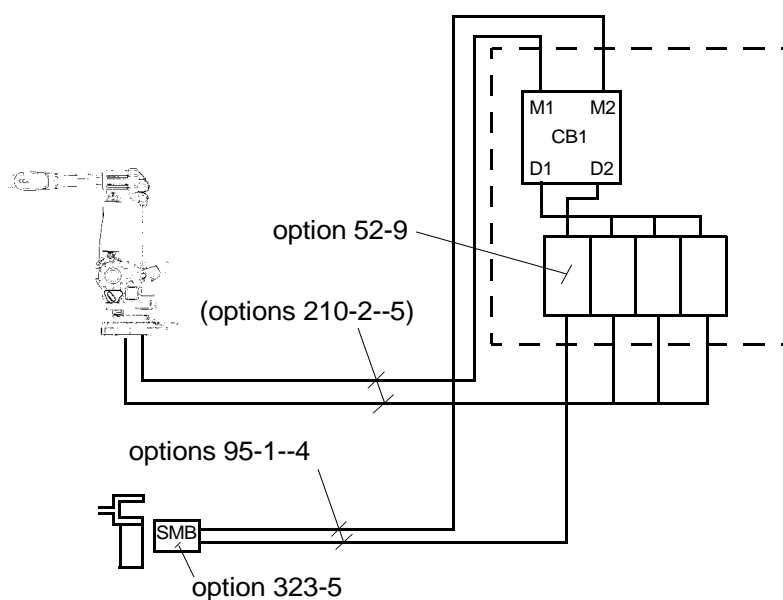

Figure 16 Configuration of Stationary Gun.

Options according to Table 14 are required to complete the deliver.
For further details see corresponding Product Specification.

Table 14

Option	Description	Product Spec.
52-9	Drive unit in control cabinet incl. cables to cabinet wall	S4Cplus
95-1--4	Cables (7-30m) between control cabinet and SG SMB box	IRB 6400R
323-5	SG Serial measurement box	S4Cplus
341-5	Software SpotWare Servo	RobotWare Options

Description

1.10.2 Robot Gun (RG)

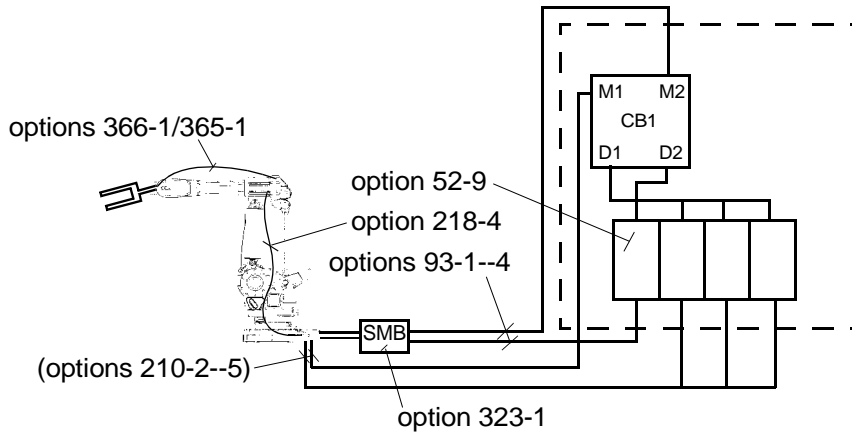

Figure 17 Configuration of Robot Gun.

Options according to Table 15 below are required to complete the delivery.
For further details see corresponding Product Specification.

Table 15

Option	Description	Product Spec.
52-9	Drive unit in control cabinet incl. cables to cabinet wall	S4Cplus
95-1--4	Cables (7-30m) between control cabinet and RG SMB box	IRB 6400R
218-4	Servo cable from robot foot to upper arm housing	IRB 6400R
366-1	Servo cable from upper arm housing to axis 6 (Std)	IRB 6400R
365-1	Extended servo cable from upper arm housing to axis 6	IRB 6400R
323-1	RG SMB box, bracket and cable SMB to robot foot	S4Cplus
341-5	Software SpotWare Servo	RobotWare Options

1.10.3 Stationary and Robot Gun (SG + RG)

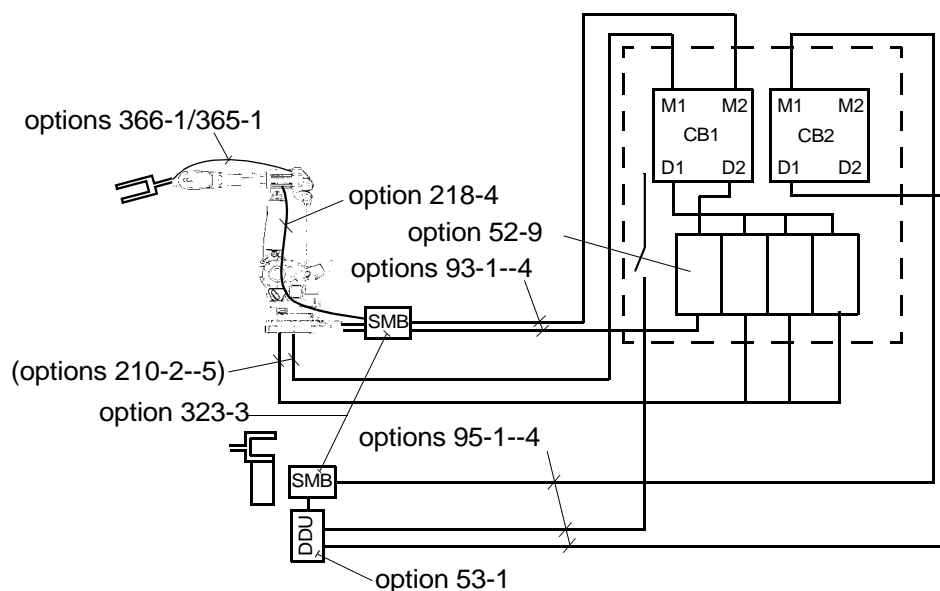

Figure 18 Configuration of Stationary and Robot Gun.

Options according to Table 16 below are required to complete the delivery.
For further details see corresponding Product Specification.

Table 16

Option	Description	Product Spec.
52-9	Drive unit in control cabinet incl. cables to cabinet wall	S4Cplus
93-1--4	Cables (7-30m) between control cabinet and RG SMB box	IRB 6400R
218-4	Servo cable from robot foot to upper arm housing	IRB 6400R
366-1	Servo cable from upper arm housing to axis 6 (Std)	IRB 6400R
365-1	Extended servo cable from upper arm housing to axis 6	IRB 6400R
323-3	RG SMB box, bracket, cable to robot foot and SG SMB box	S4Cplus
53-1	DDU in separate box and cable (1m) to SG SMB box	S4Cplus
95-1--4	Cables (7-30m) between control cabinet and SG SMB box	IRB 6400R
341-6	Software SpotWare Servo	RobotWare Options

Description

1.10.4 Twin Stationary Guns (SG + SG)

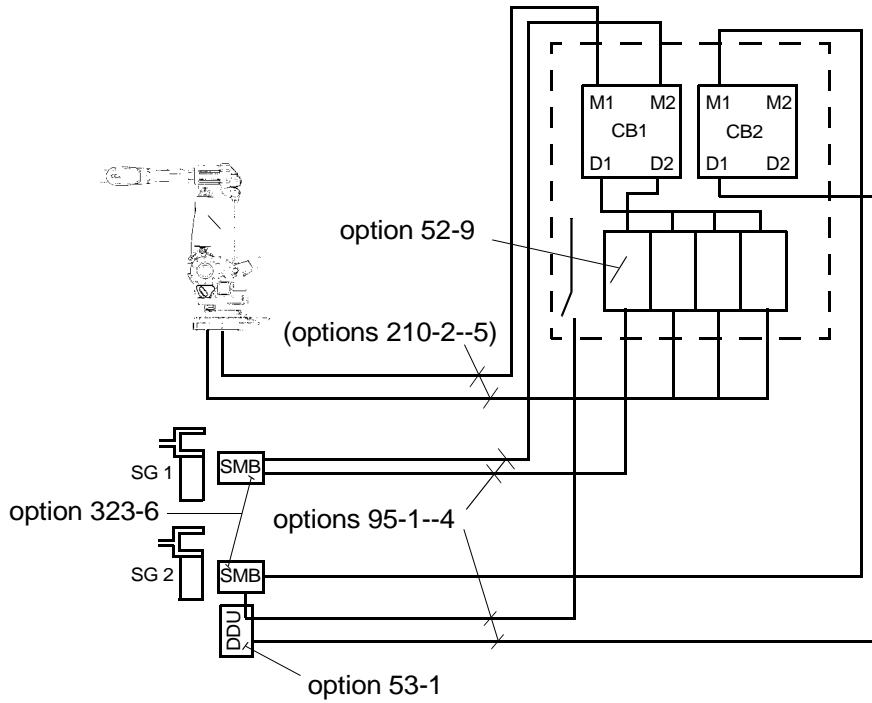

Figure 19 Configuration of Twin Stationary Guns.

Options according to Table 17 below are required to complete the delivery. For further details see corresponding Product Specification.

Table 17

Option	Description	Product Spec.
52-9	Drive unit in control cabinet incl. cables to cabinet wall	S4Cplus
95-1--4	Cables (7-30m) between control cabinet and SG1 SMB box, SG2 SMB box and SG2 DDU	IRB 6400R
323-6	SG1 SMB box and SG2 SMB box	S4Cplus
53-1	DDU in separate box and cable (1m) to SG2 SMB box	S4Cplus
341-5	Software SpotWare Servo	RobotWare Options

1.10.5 Stationary Gun and Track Motion (SG + TM)

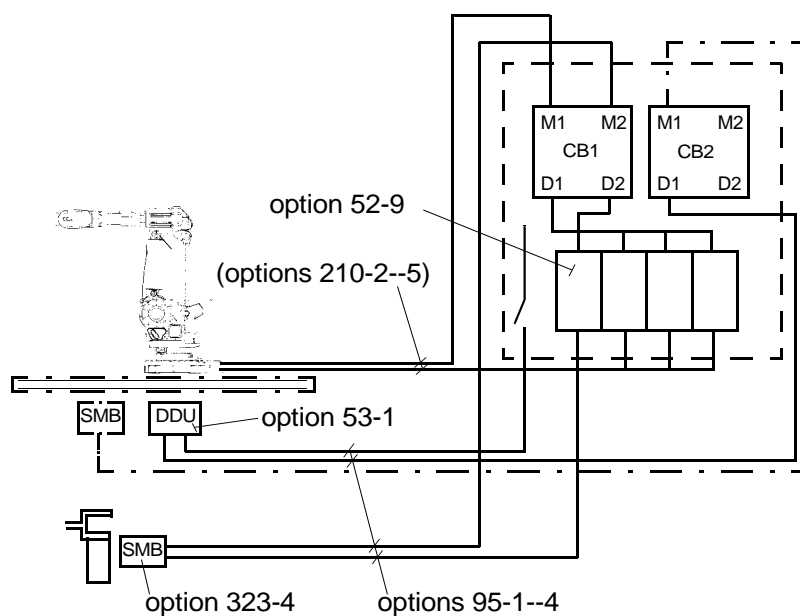

Figure 20 Configuration of Stationary Gun and Track Motion.

Options according to Table 18 below are required to complete the delivery.
For further details see corresponding Product Specification.

Note! Track Motion SMB box and cables to the control cabinet are included in the IRBT 6002/6003 delivery.

Table 18

Option	Description	Product Spec.
52-9	Drive unit in control cabinet incl. cables to cabinet wall	S4Cplus
95-1--4	Cables (7-30m) between control cabinet, SG SMB box and Track Motion DDU	IRB 6400R
323-4	SG SMB box	S4Cplus
53-1	Track Motion DDU in separate box	S4Cplus
341-5	Software SpotWare Servo	RobotWare Options

Description

1.10.6 Robot Gun and Track Motion (RG + TM)

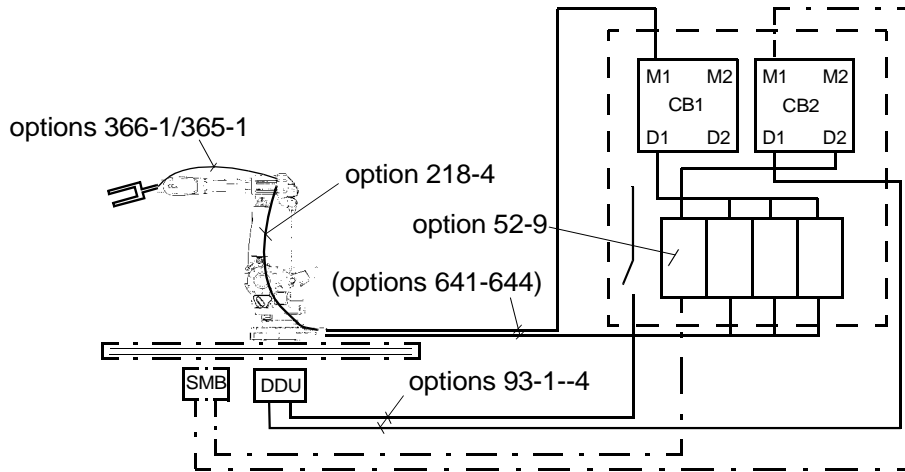

Figure 21 Configuration of Robot Gun and Track Motion.

Options according to Table 19 below are required to complete the delivery. For further details see corresponding Product Specification.

Note! Track Motion SMB box, cables to the control cabinet and cable between SMB and DDU are included in the IRBT 6002/6003 delivery.

Table 19

Option	Description	Product Spec.
52-9	Drive unit in control cabinet incl. cables to cabinet wall	S4Cplus
93-1--4 and 323-2	Cables (7-30m) between control cabinet and Track Motion DDU	IRB 6400R
218-4	Servo cable from robot foot to upper arm housing	IRB 6400R
366-1	Servo cable from upper arm housing to axis 6 (Std)	IRB 6400R
365-1	Extended servo cable from upper arm housing to axis 6	IRB 6400R
53-1	Track Motion DDU in separate box	S4Cplus
341-5	Software SpotWare Servo	RobotWare Options

2 Specification of Variants and Options

The different variants and options for the IRB 6400R are described below.
The same numbers are used here as in the Specification form. For controller options, see Product Specification S4Cplus, and for software options, see Product Specification RobotWare Options.

1 MANIPULATOR

VARIANTS

	Standard (requires option 287-4)	Foundry (requires option 287-3)
435-13	IRB 6400R/2.5-120	IRB 6400RF/2.5-120
435-14	IRB 6400R/2.5-150	IRB 6400RF/2.5-150
435-15	IRB 6400R/2.5-200	IRB 6400RF/2.5-200
435--21	IRB 6400R/2.8-150	IRB 6400RF/2.8-150
435-23	IRB 6400R/2.8-200	IRB 6400RF/2.8-200
435-26	IRB 6400R/3.0-100	IRB 6400RF/3.0-100

IRB 6400R/*Reach-Handling capacity*

Reach: Specifies the max. reach at the wrist centre.
Handling capacity: Specifies the max. handling capacity.

Manipulator colour

209-1 ABB standard
The manipulator is painted with ABB orange.

209-4--192 RAL code
The manipulator is painted with chosen RAL-colour.

Protection

287-4 Standard

287-3 Foundry
Robot adapted for foundry or other harsh environments.
The robot has the FoundryPlus protection which means that the whole manipulator is IP67 classified and steam washable. An excellent corrosion protection is obtained by a special coating. The connectors are designed for severe environment, and bearings, gears and other sensitive parts are high protected.
Only available colour is ABB orange Foundry.

145-1 Extra load upper arm
This option should be chosen if the weight of extra equipment on the upper arm exceeds 50 kg. (The manipulator is then equipped with different balancing cylinders for axis 2).
For more information, see Mounting equipment on page 15.
Not available for options 435-23, 435-26.

APPLICATION INTERFACE

Air supply and signals for extra equipment to upper arm

A hose for compressed air is integrated into the manipulator. There is an inlet at the base, see Figure 23, and an outlet on the upper arm housing or on the upper arm axis 4, see Figure 22.

Connection: G 1/2"-14 in the upper arm housing/upper arm and G 1/2"-14 at the base.

For connection of extra equipment on the manipulator, there are cables running parallel to the manipulator's cable harness with connectors on the upper arm axis 4 or on the upper arm housing. The connectors are:

- one FCI 12-pin UT071412 SH44N (CS)
- one FCI 4-pin UT07104 SH44N (CP)
- one fieldbus (opt. 053/054)

Customer connection sets for R2.CS, R2.CP, R3.CANBUS or R3.PBUS are available as options. More information in Product Manual IRB 6400R/Installation.

For connection of servo gun on the manipulator there are cables running in parallel to the manipulator's cable harness with connectors on the upper arm housing (only). The connectors are:

- one FCI 12-pin UT071412 SH44N (CMP)
- one FCI 12-pin UT071412 SH44N (CFB)

Air supply and extended signals for extra equipment to upper arm

A hose for compressed air is integrated into the manipulator. There is an inlet at the base, see Figure 23, and an outlet on the upper arm housing (only), see Figure 22.

Connection: M 22 x 1,5 mm, cone angle 24° (ISO 8434-1) both at the base and at the upper arm housing.

For connection of extra equipment which requires extended signals on the manipulator, there are cables running in parallel to the manipulator's cable harness with connectors on the upper arm housing (only). The connectors are:

- one FCI 19-pin MSK07C1419S (CS)
- one FCI 6-pin MSK07C106S (CP)
- one FCI 10-pin MSK07C1210S (opt. 17-1/17-4)

For connection of servo gun which requires extended signals on the manipulator there are cables running in parallel to the manipulator's cable harness with connectors on the upper arm housing (only). The connectors are:

- one FCI 12-pin UT071412SH44N (CMP)
- one FCI 12-pin UT071412SH44N (CFB)

Media outlet

- 218-8** At upper arm housing
For specification of connections, see Chapter 1.6, Table 1.
- 218-6** At upper arm axis 4
For specification of connections, see Chapter 1.6, Table 1.
- 218-4** Servo Gun cabling
For specification of connections, see Chapter 1.6, Table 2.

Extended signals with connection to

- 141-2 Manipulator** (Cables from robot base to axis 3)
The extended signals are connected directly to the manipulator base to one heavy duty industrial housing with three D-sub connector inserts, R1.CP/CS (see Figure 23).
The cables from the cabinet to the manipulator base are not supplied.
For specification of connections, see Chapter 1.6, Table 3.
- 141-1 Cabinet** (Cables from controller to axis 3)
The extended signals CP/CS comes from the cabinet, through cable glands, and are connected to the manipulator base.
The cables between the controller and R1.CP/CS are supplied.
For specification of connections, see Chapter 1.6, Table 3.

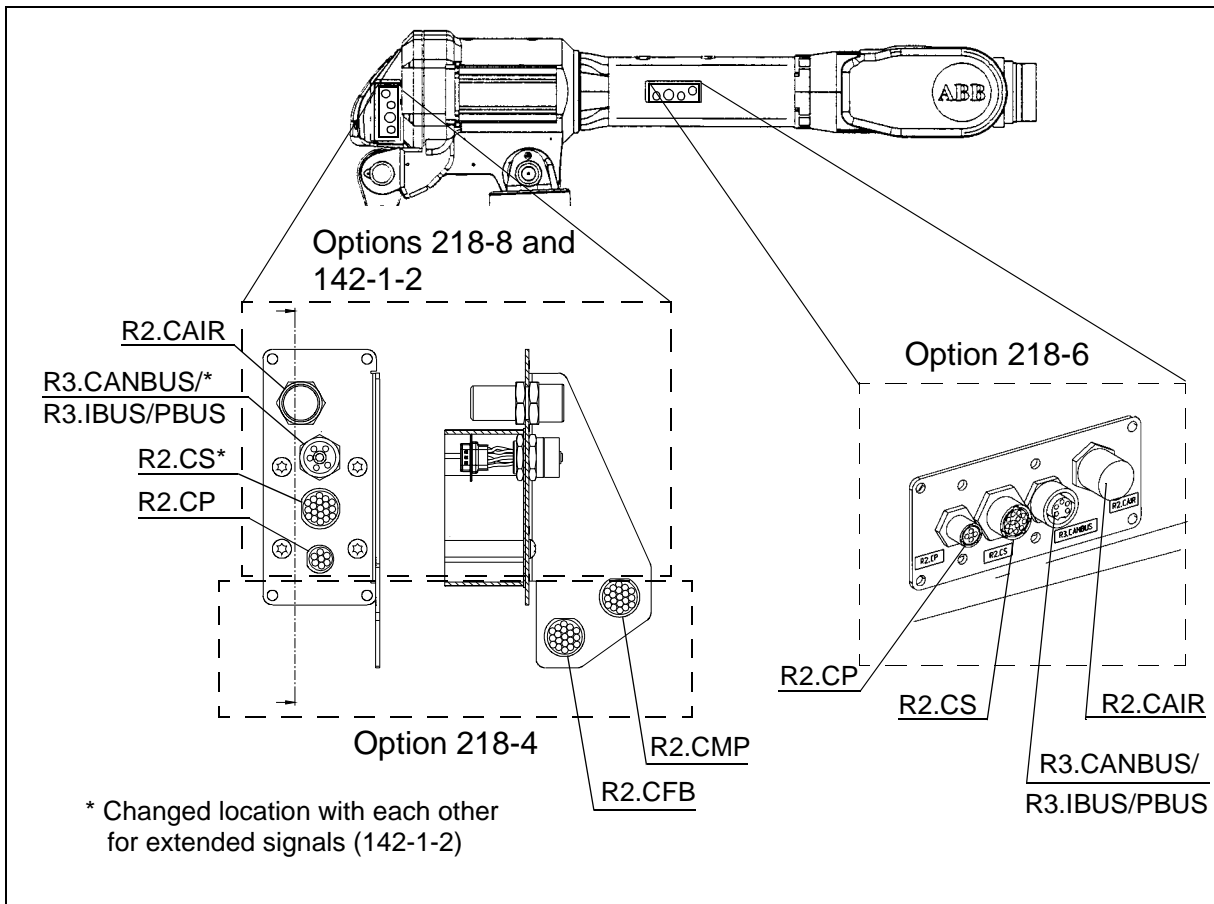

Figure 22 Location of customer connections on upper arm / armhouse.

Specification of Variants and Options

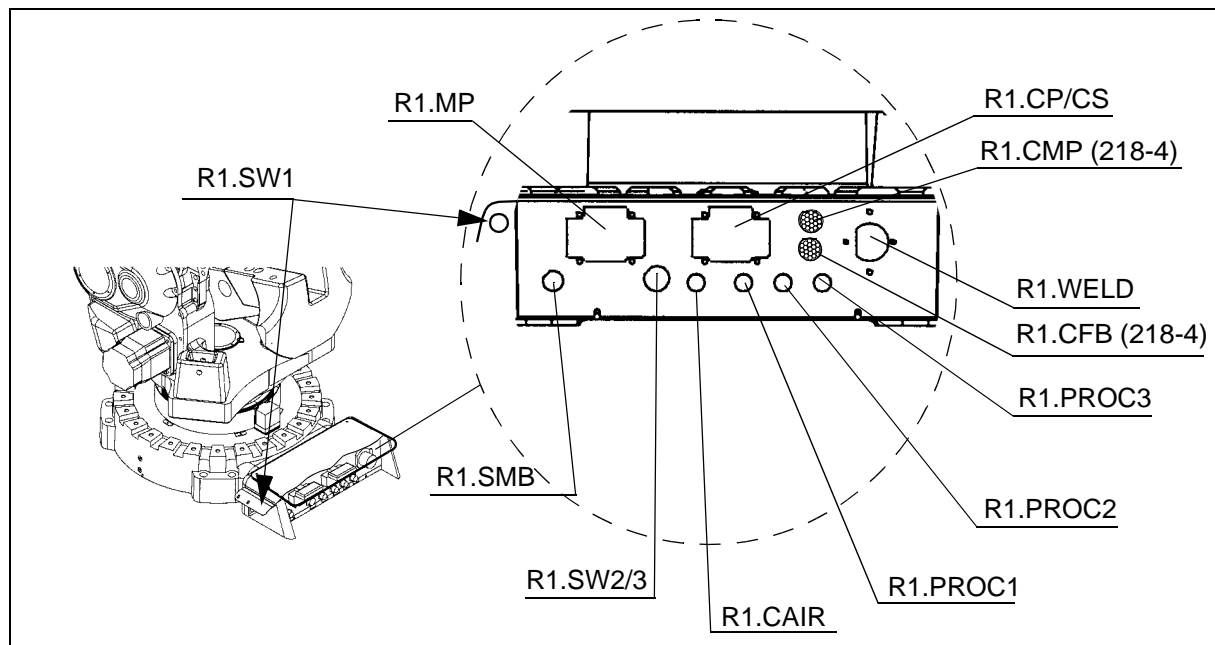

Figure 23 Location of customer connections on base.

Connection to

16-2 Manipulator

The signals are connected directly to the manipulator base to one heavy duty industrial housing with three D-sub connector inserts, R1.CP/CS (see Figure 23). The cables from the manipulator base are not supplied. (The foundry version, option 287-3, has a housing for extra harsh environment)

16-1 Cabinet

The signals CP/CS are connected to 12-pole screw terminals, Phoenix MSTB 2.5/12-ST-5.08, in the controller. The cable between R1.CP/CS and the controller is supplied.

Connectors type

Type of fieldbus connectors on the upper arm

17-1 Can/DeviceNet, R3.CANBUS

5-pin “Mini” style female connector with 7/8-16 UN-2A THD female connection thread. Meets ANSI/B93.55M-1981 design and intermateability requirements.

17-4 Profibus, R3.PBUS

9-pin connector with M23 connection thread.

Connection to cabinet (Cable lengths)

CanDeviceNet/Profibus/Robot ServoGun/Stational ServoGun

90-2/92-2/93-1/95-1	7m
90-3/92-3/93-2/95-2	15m
90-4/92-4/93-3/95-3	22m
90-5/92-5/93-4/95-4	30m

359-1 Spotweld Base Harness

Integrated spotweld base harness with primary current (R1.WELD) and media supplies (R1.PROC1-3), connected to the upper arm housing, see Figure 24 and to the manipulator base, see Figure 23.

The harness remains within the manipulator's max. radius envelope for axis 1.

Connection on the manipulator base: Current; Multi-Contact TSS+2/25

Water; G1/2"-14 outer thread, cone angle 60° (BSPP)

Connection on the upper arm housing: Current; Multi-Contact TSB+2/25

Water; G1/2"-14 outer thread, cone angle 60° (BSPP)

Customer connection sets for for R1.Weld and R2.Weld are available as options.

More information in Product Manual IRB 6400R/Installation.

This option is only available if option 218-8 is chosen.

This option is not available for option 287-3 Foundry, neither if option 361-1 nor 282-1 Process media conduit is chosen.

For specification of connections, see Chapter 1.7, Table 4.

361-1 Spotweld Base Harness Extended

Integrated spotweld base harness extended with primary current (R1.WELD) and media supplies (R1.PROC1-3). Connected to the upper arm housing, see Figure 24, and to the manipulator base, see Figure 23.

The harness remains within the manipulator's max. radius envelope for axis 1.

Connection on the manipulator base: Current; Multi-Contact TSS+2/25.

Media supplies fittings; M22 x 1,5 outer thread, cone angle 24° (ISO 8434-1).

Connection on the upper arm housing: Current; Multi-Contact TSB+2/25

Media supplies fittings; M22 x 1,5 outer thread, cone angle 24° (ISO 8434-1).

More information in Product Manual IRB 6400R/Installation.

This option is only available if option 141-2 or 141-1 is chosen.

This option is not available for option 287-3 Foundry, neither if option 359-1 Spotweld base harness nor option 282-1 Process media conduit is chosen.

For specification of connections, see Chapter 1.7, Table 5.

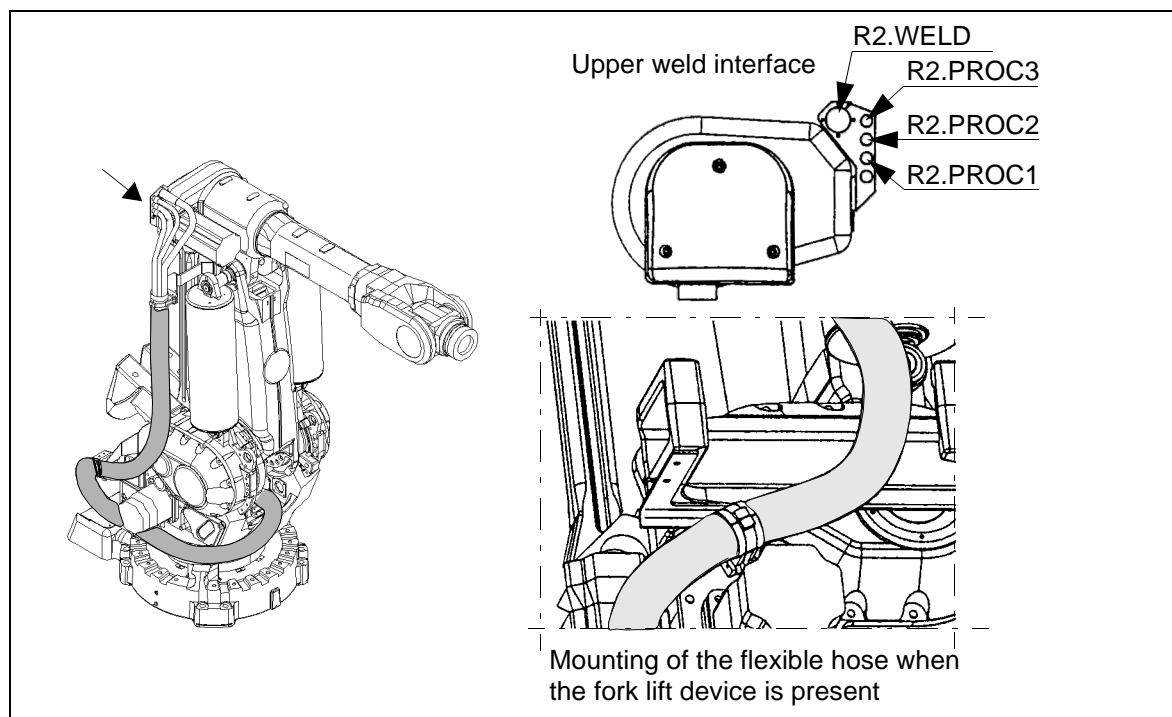

Figure 24 Mounted Spotweld base harness and Spotweld base harness extended.

Specification of Variants and Options

282-1 Process media conduit

An external flexible conduit for supplying process media from the base up to the upper arm housing. The flexible hose has the diameter of 80/67 mm. The harness remains within the manipulators max envelope for axis 1 of 530 mm. The flexible hose is attached to the base, frame and lower arm. See Figure 25.

The hoses/cables inside the conduit is to be designed by the user. Cable hose clamps in both ends. The clamps are included.

This option is not available if option 359-1 Spotweld Base Harness or option 361-1 Spotweld Base Harness Extended is chosen.

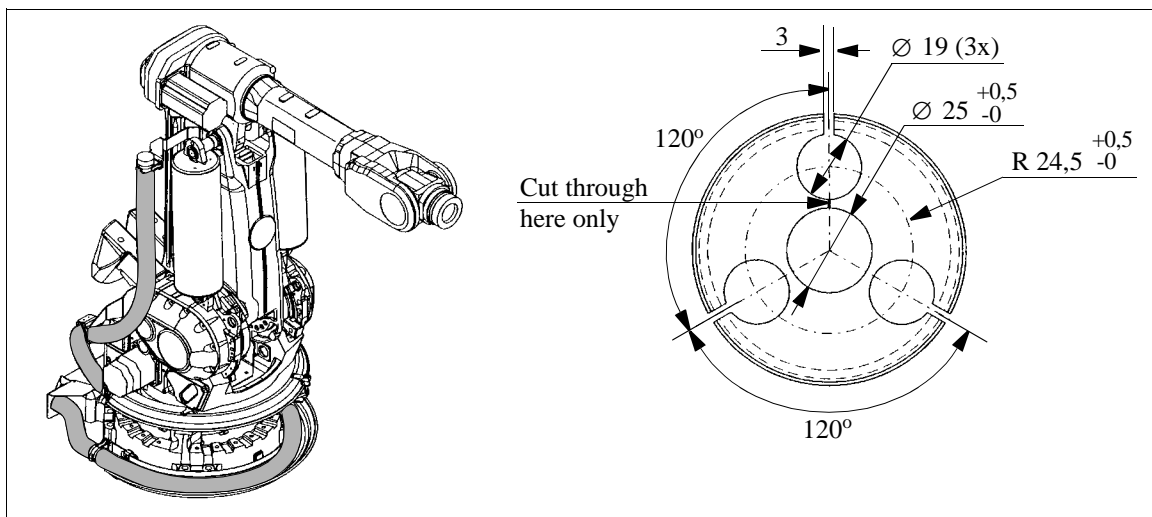

Figure 25 Mounted Process media conduit and cable hose clamp (dimensions in mm).

UPPER ARM HARNESS

The upper arm harness consists of cables and hoses inside a protective hose, see Figure 26. Cables, hoses and the protective hose are designed to follow the robot arm movements without causing any damages to the harness or to the manipulator arm. The hose package is adapted to the robot structure with special designed supports, clamps, brackets etc. The complete harness is tested and proven to be well suited for material handling as well as spotwelding applications with the same type of movements and very high requirements.

The cables and the hose package has a 800 mm free end at axis 6 for connection to a gripper or a transformer spotwelding gun. A tension arm unit keeps the hose package in the right position for any manipulator arm movement approved for the Dresspack. A protection kit consists of covers for the arm and the wrist and will prevent wear on the protective hose and on the arm itself.

For more information see Product Manual IRB 6400R, Installation and Maintenance.

223-1 MH Standard

For specification of connections for material handling with standard signals, see Chapter 1.8, Table 6.

222-1 MH Extended

For specification of connections for material handling with extended signals, see Chapter 1.8, Table 7.

364-1 SW Pneumatic Standard

For specification of connections for spotwelding with pneumatic gun and standard signals, see Chapter 1.8 Table 8.

451-1 SW Pneumatic Extended

For specification of connections for spotwelding with pneumatic gun and extended signals, see Chapter 1.8 Table 10.

366-1 SW Servo Standard

For specification of connections for spotwelding with servo gun and standard signals, see Chapter 1.8 Table 9.

365-1 SW Servo Extended

For specification of connections for spotwelding with servo gun and extended signals, see Chapter 1.8 Table 11.

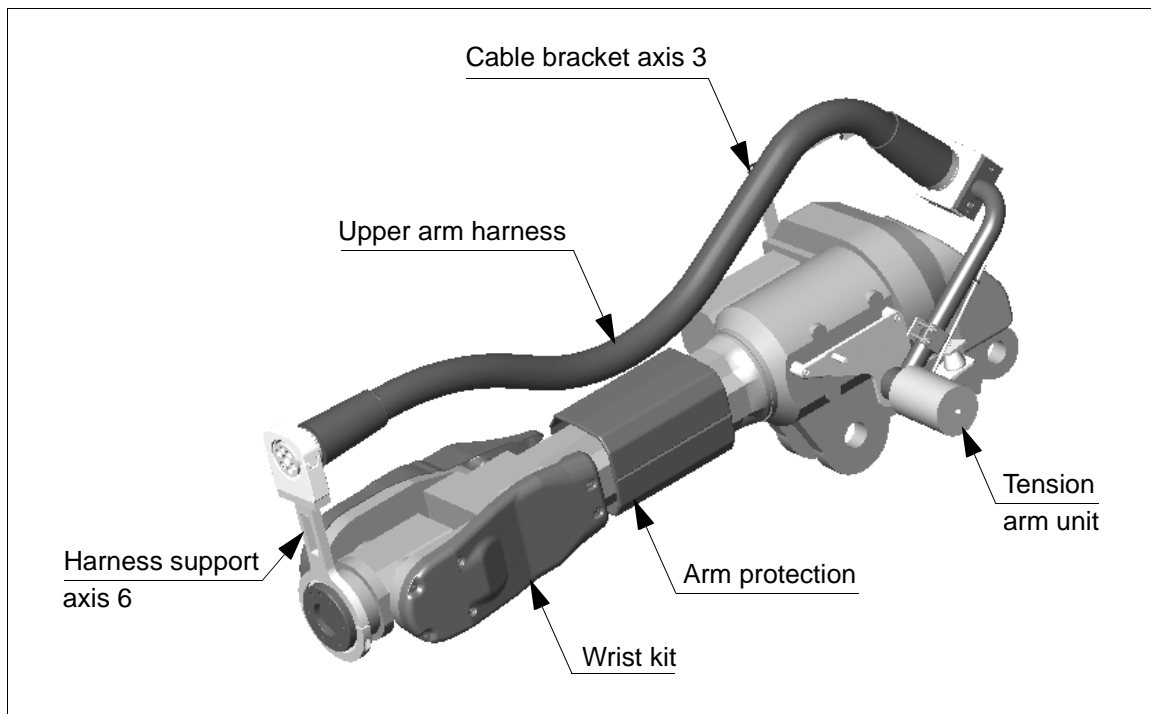

Figure 26 Principal drawing of mounted upper arm harness.

CONNECTOR KITS

Detached connectors are suitable to the connectors for the application interface, position switches and spotweld harness.

The kit consists of connectors, pins and sockets.

431-1 Upper arm

For the connectors on the upper arm housing, option 218-8 and upper arm axis 4, option 218-6.

239-1 On foot

For the application interface connectors on the foot with connection to manipulator, option 16-2 and media outlet at upper arm housing, option 218-8 or at upper arm axis 4, option 218-6.

Specification of Variants and Options

275-1 Position switches

For the position switches connectors on the base with connection to manipulator, option 271-2 and position switches.

362-1 SW harness

For the spotweld harness connectors on the base, option 359-1.

EQUIPMENT

213-1 Safety lamp

A safety lamp with an orange fixed light can be mounted on the manipulator. The lamp is active in MOTORS ON mode. The safety lamp is required on a UL/UR approved robot.

159-1 Fork lift device

Lifting device on the manipulator for fork-lift handling is mounted at delivery. Lifting eyes for use with an overhead crane are integrated as standard.

84-1 Cooling for axis 1 motor

Extra cooling of axis 1 motor is recommended in heavy duty application e.g. in press tending application.

This option is not available for option 287-3 Foundry.

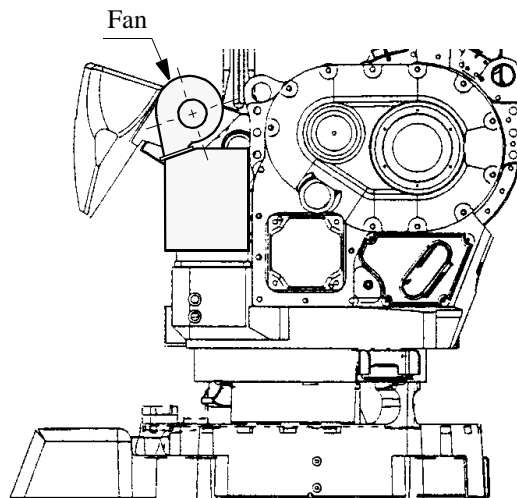

Figure 27 Location of the fan on the manipulator.

50-1 Brake release cover

Protective cover over push-buttons on brake release unit. Always included for Foundry versions.

184-1 Insulated flange

Electrically insulated tool flange. In case of an electrical fault in the spot welding equipment mounted on the tool flange, the tool flange withstands dangerous voltage (100V AC during 60 seconds or 300V AC during 10 seconds) in non water applications without passing it further to electronics in the robot and controller. See Figure 28.

Not available with option 287-3, Foundry.

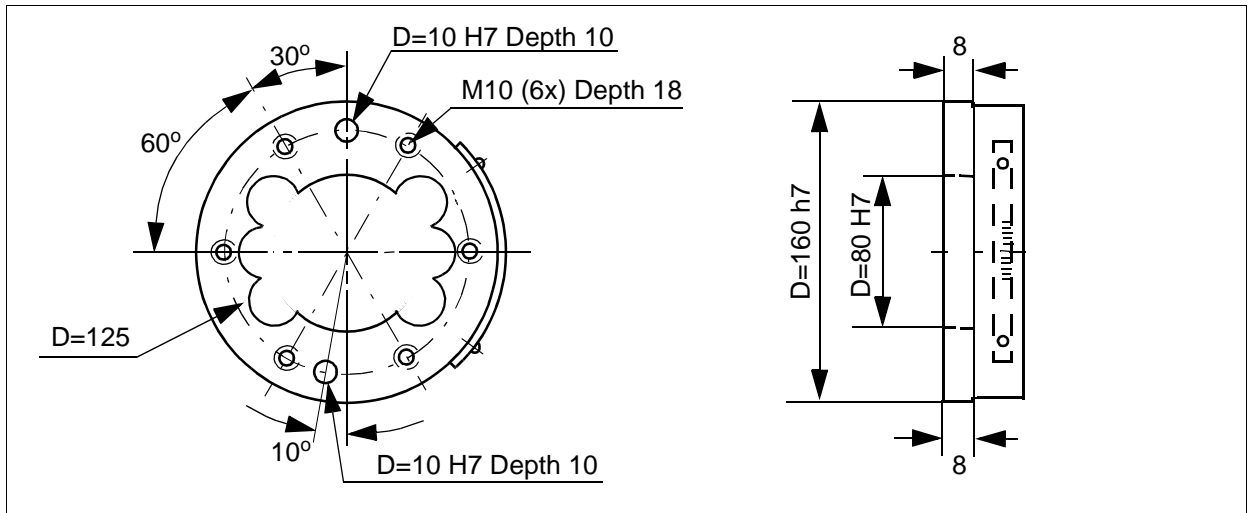

Figure 28 The mechanical interface of the insulated flange (dimensions in mm).

POSITION SWITCHES

Position switches indicating the position of the three main axes. Rails with separate adjustable cams are attached to the manipulator. The cams, which have to be adapted to the switch function by the user, can be mounted in any position in the working range for each switch. No machining operation of the cams is necessary for the adaption, simple hand tools can be used.

For axis 1 there are three position switch functions available. For axes 2 and 3 one position switch function each.

Each position switch function consists of two switches mechanically operated by separate cams. Each switch has one normal open and one normal closed contact.

See the exception for axis 1.

The design and components fulfill the demands to be used as safety switches.

This options may require external safety arrangements, e.g. light curtains, photocells or contact mats.

The switches can be connected either to the manipulator base (R1.SW1 and R1.SW2/3, see Figure 23), or to the controller. In the controller the signals are connected to screw terminal XT8 Phoenix MSTB 2.5/12-ST-5.08.

Switch type Balluff Multiple position switches BNS, according to EN 60947-5-1 and EN 60947-5-2.

Connection to

271-2 Manipulator

Connection on the manipulator base with one/two FCI 23-pin connector.

Customer connection sets for R1.SW1 and R1.SW2/3 are available as option.

More information in Product Manual IRB 6400R/Installation.

271-1 Cabinet

Connection on the cabinet wall. Position switch cables are included.

Position switches axis 1

25-2 One switch

Specification of Variants and Options

25-3 Three switches

Connection of signals axis 1 (cable lengths)

273-1 7m

273-2 15m

273-3 22m

273-4 30m

30-1 Position switches axis 2

Only available if option 218-8 or 218-6 is chosen.

Not available with option 287-3 (foundry).

33-1 Position switches axis 3

Only available if options 218-8 or 218-6, and 30-1 are chosen.

Not available with option 287-3 (foundry).

Connection of signals axes 2 and 3 (cable lengths)

274-1 7m

274-2 15m

274-3 22m

274-4 30m

WORKING RANGE LIMIT

To increase the safety of the robot, the working range of axes 1, 2 and 3 can be restricted by extra mechanical stops.

Axis 1

29-2 Stops which allow the working range to be restricted in increments of 7,5°.

29-1 Stops which allow the working range to be restricted in increments of 15°.

32-1 Axis 2

Six stops which allow the working range to be restricted in increments of 15° at both end positions. Each stop decreases the motion by 15°.

34-1 Axis 3

Six stops which allow the working range to be restricted in increments of 15° at both end positions. Each stop decreases the motion by 15°.

3 Accessories

There is a range of tools and equipment available, specially designed for the robot.

Basic software and software options for robot and PC

For more information, see Product Specification S4Cplus, and Product Specification RobotWare Options.

Robot Peripherals

- Track Motion
- Tool System
- Motor Units
- Spot welding system for transformer gun

Accessories

4 Index

A

accessories 43
air supply 34
application interface 22

B

brake release cover 40

C

Can/DeviceNet 36
colours 33
cooling device 4
cooling for axis 1 motor 40
customer connections 35, 36

D

dresspack examples 26

E

emergency stop 7
enabling device 6
equipment
 mounting 15
 permitted extra load 15
extra equipment
 connections 34

F

fan 40
fire safety 7
Foundry variants 33

H

hold-to-run control 7
humidity 8

I

installation 8
insulated flange 40

L

lifting device 40
load 8
load diagrams 10

M

maintenance 19
manipulator colour 33
mechanical interface 18
media outlet 35
motion 20
mounting
 extra equipment 15
 robot 8
mounting flange 18

N

noise level 4

O

operating requirements 8
options 33
overspeed protection 7

P

payload 8
performance 21
position switches 41
process media conduit 38
Profibus 36
protection standards 8

R

range of movement 20
reduced speed 6
repeatability 21
Robot Gun 28
Robot Gun and Track Motion 32
Robot Peripherals 43
robot versions 4

S

safeguarded space stop 7
 delayed 7

Index

- safety 6
- safety lamp 7, 40
- service 19
- Servo Gun 27
- signal connections 34
- signals 22
- space requirements 4
- Spotweld Harness 37
- standards 6
- Stationary and Robot Gun 29
- Stationary Gun 27
- Stationary Gun and Track Motion 31
- structure 3

T

- temperature 8
- troubleshooting 19
- Twin Stationary Guns 30

V

- variants 33

W

- weight 4
- working space
 - restricting 7, 8, 42