

# FurseWELD

## Cable to steel surface & pipe CS1 & CS2

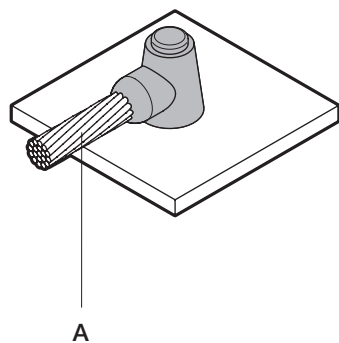

### Cable to steel surface & pipe CS1 - FurseWELD

Stranded / Solid Circular Conductor Size A (mm <sup>2</sup> )	Part No.		
	Powder Cartridge	Standard Mould	Handle Clamps
16	Use CS8		
25	Use CS8		
35	Use CS8		
8 mm ø	90P10	CS1-4-8SC	HCPK4
50	90P10	CS1-4-50-FU	HCPK4
10 mm ø	90P10	CS1-4-10SC	HCPK4
70	90P10	CS1-4-70	HCPK4
95	115P10	CS1-4-95	HCPK4
120	115P10	CS1-4-120	HCPK4
150	150P10	CS1-4-150	HCPK4
185	200P10	CS1-4-185	HCPK4
240	200P10	CS1-4-240	HCPK4
300	250P10	CS1-4-300	HCPK4

Special moulds for all FurseWELD products can be manufactured to meet specific customer applications on request

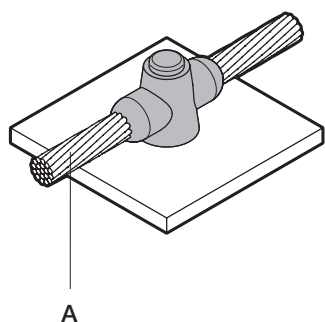

### Cable to steel surface & pipe CS2 - FurseWELD

Stranded / Solid Circular Conductor Size A (mm <sup>2</sup> )	Part No.		
	Powder Cartridge	Standard Mould	Handle Clamps
16	Use CS9		
25	Use CS9		
35	Use CS9		
8 mm ø	90P10	CS2-4-8SC	HCPK4
50	90P10	CS2-4-50	HCPK4
10 mm ø	115P10	CS2-4-10SC	HCPK4
70	115P10	CS2-4-70	HCPK4
95	115P10	CS2-4-95	HCPK4
120	150P10	CS2-4-120	HCPK4
150	200P10	CS2-4-150	HCPK4
185	250P10	CS2-4-185	HCPK4
240	2 x 150P10	CS2-5-240	HCPK5
300	2 x 200P10	CS2-5-300	HCPK5

Special moulds for all FurseWELD products can be manufactured to meet specific customer applications on request

# FurseWELD

## Cable to steel surface & pipe CS3 & CS7

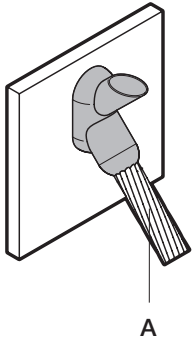

### Cable to steel surface & pipe CS3 - FurseWELD

Stranded / Solid Circular Conductor Size A (mm <sup>2</sup> )	Part No.				
	Powder Cartridge	Standard Mould	Handle Clamps	Mini Mould	Mini Handle Clamps
16 *	45P10	CS3-4-16	HCPK4	CS3-3-16	HCPK3
25	45P10	CS3-4-25	HCPK4	CS3-3-25	HCPK3
35	45P10	CS3-4-35	HCPK4	CS3-3-35	HCPK3
8 mm ø	65P10	CS3-4-8SC	HCPK4	CS3-3-8SC	HCPK3
50	65P10	CS3-4-50	HCPK4	CS3-3-50	HCPK3
10 mm ø	90P10	CS3-4-10SC	HCPK4	CS3-3-10SC	HCPK3
70	90P10	CS3-4-70	HCPK4	CS3-3-70	HCPK3
95	115P10	CS3-4-95	HCPK4	CS3-3-95	HCPK3
120	115P10	CS3-4-120	HCPK4	CS3-3-120	HCPK3
150	115P10	CS3-4-150	HCPK4	CS3-3-150	HCPK3
185	200P10	CS3-4-185	HCPK4	–	–
240	200P10	CS3-4-240	HCPK4	–	–
300	250P10	CS3-4-300	HCPK4	–	–

Special moulds for all FurseWELD products can be manufactured to meet specific customer applications on request  
 \*1 x S103 Sleeve required when joining conductors smaller than 16 mm<sup>2</sup>

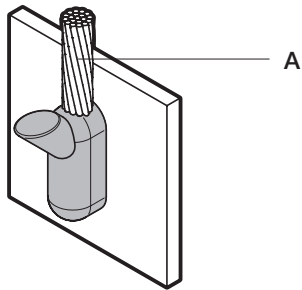

### Cable to steel surface & pipe CS7 - FurseWELD

Stranded / Solid Circular Conductor Size A (mm <sup>2</sup> )	Part No.				
	Powder Cartridge	Standard Mould	Handle Clamps	Mini Mould	Mini Handle Clamps
16 *	65P10	CS7-4-16	HCPK4	CS7-3-16	HCPK3
25	65P10	CS7-4-25	HCPK4	CS7-3-25	HCPK3
35	65P10	CS7-4-35	HCPK4	CS7-3-35	HCPK3
8 mm ø	90P10	CS7-4-8SC	HCPK4	CS7-3-8SC	HCPK3
50	90P10	CS7-4-50	HCPK4	CS7-3-50	HCPK3
10 mm ø	150P10	CS7-4-10SC	HCPK4	–	–
70	150P10	CS7-4-70	HCPK4	–	–
95	200P10	CS7-5-95	HCPK4	–	–
120	200P10	CS7-5-120	HCPK4	–	–
150	250P10	CS7-5-150	HCPK4	–	–
185	2 x 150P10	CS7-9-185	HCPK4	–	–
240	2 x 150P10	CS7-9-240	HCPK4	–	–
300	2 x 200P10	CS7-10-300	HCPK5	–	–

Special moulds for all FurseWELD products can be manufactured to meet specific customer applications on request  
 \*1 x S103 Sleeve required when joining conductors smaller than 16 mm<sup>2</sup>

# FurseWELD

## Cable to steel surface & pipe CS8 & CS9

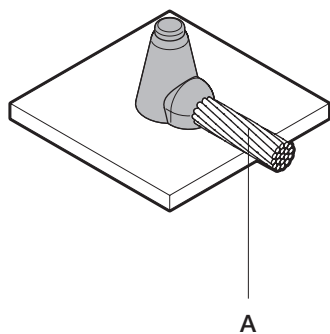

### Cable to steel surface & pipe CS8 - FurseWELD

Stranded / Solid Circular Conductor Size A (mm <sup>2</sup> )	Part No.		
	Powder Cartridge	Standard Mould	Handle Clamps
16 *	45P10	CS8-2-16	HCPK2
25	45P10	CS8-2-25	HCPK2
35	45P10	CS8-2-35	HCPK2
8 mm ø	45P10	CS8-2-8SC	HCPK2
50	45P10	CS8-2-50	HCPK2
10 mm ø	65P10	CS8-2-10SC	HCPK2
70	65P10	CS8-2-70	HCPK2
95	90P10	CS8-2-95	HCPK2
120	115P10	CS8-4-120	HCPK4
150	150P10	CS8-4-150	HCPK4
185	200P10	CS8-4-185	HCPK4
240	200P10	CS8-4-240	HCPK4
300	250P10	CS8-4-300	HCPK4

Special moulds for all FurseWELD products can be manufactured to meet specific customer applications on request  
 \*1 x S103 Sleeve required when joining conductors smaller than 16 mm<sup>2</sup>

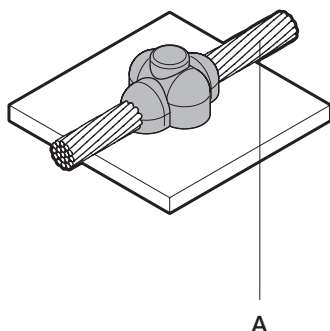

### Cable to steel surface & pipe CS9 - FurseWELD

Stranded / Solid Circular Conductor Size A (mm <sup>2</sup> )	Part No.		
	Powder Cartridge	Standard Mould	Handle Clamps
16 *	45P10	CS27-4-16	HCPK4
25	45P10	CS27-4-25	HCPK4
35	45P10	CS27-4-35	HCPK4
8 mm ø	65P10	CS27-4-8SC	HCPK4
50	65P10	CS27-4-50	HCPK4
10 mm ø	115P10	CS27-4-10SC	HCPK4
70	115P10	CS27-4-70	HCPK4
95	150P10	CS27-4-95	HCPK4
120	150P10	CS27-4-120	HCPK4
150	200P10	CS27-5-150	HCPK5
185	250P10	CS27-5-185	HCPK5
240	2 x 150P10	CS27-5-240	HCPK5
300	2 x 200P10	CS27-5-300	HCPK5

Special moulds for all FurseWELD products can be manufactured to meet specific customer applications on request  
 \*1 x S103 Sleeve required when joining conductors smaller than 16 mm<sup>2</sup>



# FurseWELD

## Cable to steel surface & pipe CS25 & CS27

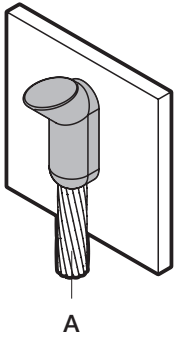

A

### Cable to steel surface & pipe CS25 - FurseWELD

Stranded / Solid Circular Conductor Size A (mm <sup>2</sup> )	Part No.				
	Powder Cartridge	Standard Mould	Handle Clamps	Mini Mould	Mini Handle Clamps
16 *	45P10	CS25-4-16	HCPK4	CS25-3-16	HCPK3
25	45P10	CS25-4-25	HCPK4	CS25-3-25	HCPK3
35	45P10	CS25-4-35	HCPK4	CS25-3-35	HCPK3
8 mm $\phi$	65P10	CS25-4-8SC	HCPK4	CS25-3-8SC	HCPK3
50	65P10	CS25-4-50	HCPK4	CS25-3-50	HCPK3
10 mm $\phi$	90P10	CS25-4-10SC	HCPK4	-	-
70	90P10	CS25-4-70	HCPK4	CS25-3-70	HCPK3
95	115P10	CS25-4-95	HCPK4	-	-
120	115P10	CS25-4-120	HCPK4	-	-
150	150P10	CS25-4-150	HCPK4	-	-
185	200P10	CS25-4-185	HCPK4	-	-
240	200P10	CS25-4-240	HCPK4	-	-
300	250P10	CS25-4-300	HCPK4	-	-

Special moulds for all FurseWELD products can be manufactured to meet specific customer applications on request  
 \*1 x S103 Sleeve required when joining conductors smaller than 16 mm<sup>2</sup>

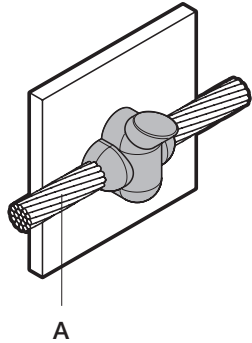

A

### Cable to steel surface & pipe CS27 - FurseWELD

Stranded / Solid Circular Conductor Size A (mm <sup>2</sup> )	Part No.		
	Powder Cartridge	Standard Mould	Handle Clamps
16 *	45P10	CS27-4-16	HCPK4
25	45P10	CS27-4-25	HCPK4
35	45P10	CS27-4-35	HCPK4
8 mm $\phi$	65P10	CS27-4-8SC	HCPK4
50	65P10	CS27-4-50	HCPK4
10 mm $\phi$	115P10	CS27-4-10SC	HCPK4
70	115P10	CS27-4-70	HCPK4
95	150P10	CS27-4-95	HCPK4
120	150P10	CS27-4-120	HCPK4
150	200P10	CS27-5-150	HCPK5
185	250P10	CS27-5-185	HCPK5
240	2 x 150P10	CS27-5-240	HCPK5
300	2 x 200P10	CS27-5-300	HCPK5

Special moulds for all FurseWELD products can be manufactured to meet specific customer applications on request  
 \*1 x S103 Sleeve required when joining conductors smaller than 16 mm<sup>2</sup>



# FurseWELD

## Cable to steel surface & pipe CS32

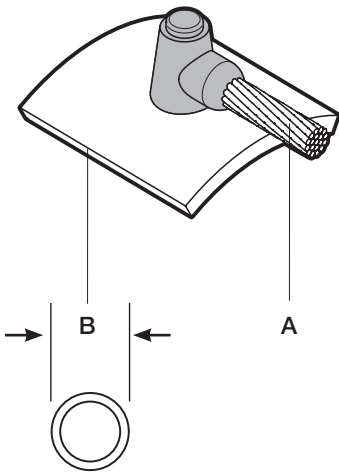

Cable to steel surface & pipe CS32 - FurseWELD

Stranded Conductor Size A (mm <sup>2</sup> )	Stranded Conductor Size B ø (mm)	Part No.			
		Powder Cartridge	Standard Mould	Handle Clamps	Sleeves
2.5	< 125	15P10	CS32-1-2.5-A	HCPK1	1 x S105
2.5	> 125	15P10	CS32-1-2.5-B	HCPK1	1 x S105
4	< 125	15P10	CS32-1-4-A	HCPK1	1 x S105
4	> 125	15P10	CS32-1-4-B	HCPK1	1 x S105
6	< 125	15P10	CS32-1-6-A	HCPK1	1 x S105
6	> 125	15P10	CS32-1-6-B	HCPK1	1 x S105
10	< 125	25P10	CS32-1-10-A	HCPK1	1 x S102
10	> 125	25P10	CS32-1-10-B	HCPK1	1 x S102
16	< 125	45P10	CS32-2-16-A	HCPK2	1 x S103
16	> 125	45P10	CS32-2-16-B	HCPK2	1 x S103
25	< 70	25P10	CS32-1-25-C	HCPK1	-
25	70-165	25P10	CS32-1-25-D	HCPK1	-
25	> 165	25P10	CS32-1-25-E	HCPK1	-
35	< 70	45P10	CS32-2-35-C	HCPK2	-
35	70-165	45P10	CS32-2-35-D	HCPK2	-
35	165-250	45P10	CS32-2-35-F	HCPK2	-
35	> 250	45P10	CS32-2-35-G	HCPK2	-
50	< 70	45P10	CS32-2-50-C	HCPK2	-
50	70-165	45P10	CS32-2-50-D	HCPK2	-
50	165-250	45P10	CS32-2-50-F	HCPK2	-
50	> 250	45P10	CS32-2-50-G	HCPK2	-
70	< 70	65P10	CS32-2-70-C	HCPK2	-
70	70-165	65P10	CS32-2-70-D	HCPK2	-
70	165-250	65P10	CS32-2-70-F	HCPK2	-
70	> 250	65P10	CS32-2-70-G	HCPK2	-

Special moulds for all FurseWELD products can be manufactured to meet specific customer applications on request



# FurseWELD

## Cable to steel surface & pipe CS34

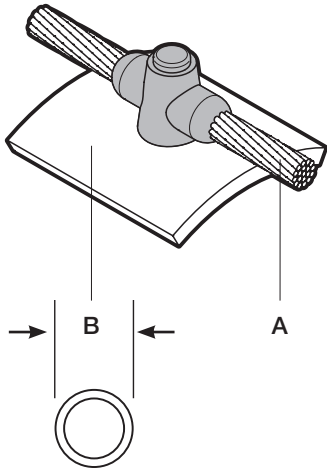

Cable to steel surface & pipe CS34 - FurseWELD

Stranded Conductor Size A (mm <sup>2</sup> )	Conductor Size B ø (mm)	Part No.			
		Powder Cartridge	Standard Mould	Handle Clamps	Sleeves
2.5	< 125	15P10	CS34-2-2.5-A	HCPK2	2 x S105
2.5	> 125	15P10	CS34-2-2.5-B	HCPK2	2 x S105
4	< 125	15P10	CS34-2-4-A	HCPK2	2 x S105
4	> 125	15P10	CS34-2-4-B	HCPK2	2 x S105
6	< 125	15P10	CS34-2-6-A	HCPK2	2 x S105
6	> 125	15P10	CS34-2-6-B	HCPK2	2 x S105
10	< 125	32P10	CS34-2-10-A	HCPK2	2 x S102
10	> 125	32P10	CS34-2-10-B	HCPK2	2 x S102
16	< 125	45P10	CS34-2-16-A	HCPK2	2 x S103
16	> 125	45P10	CS34-2-16-B	HCPK2	2 x S103
25	< 70	32P10	CS34-2-25-C	HCPK2	—
25	70-165	32P10	CS34-2-25-D	HCPK2	—
25	> 165	32P10	CS34-2-25-E	HCPK2	—
35	< 70	45P10	CS34-2-35-C	HCPK2	—
35	70-165	45P10	CS34-2-35-D	HCPK2	—
35	165-250	45P10	CS34-2-35-F	HCPK2	—
35	> 250	45P10	CS34-2-35-G	HCPK2	—
50	< 70	65P10	CS34-2-50-C	HCPK2	—
50	70-165	65P10	CS34-2-50-D	HCPK2	—
50	165-250	65P10	CS34-2-50-F	HCPK2	—
50	> 250	65P10	CS34-2-50-G	HCPK2	—

Special moulds for all FurseWELD products can be manufactured to meet specific customer applications on request

