



Product brochure

# Medium voltage AC drive ACS 6000, 3 – 27MW, up to 3.3 kV



# ACS 6000 – one of the world’s most successful MV multidrives

ABB’s ACS 6000 medium voltage drive provides the optimum solution for applications where high power and maximum reliability is required. Since its introduction, the ACS 6000 has gained an excellent reputation for high quality and reliability. As a result ABB has worldwide one of the largest installed bases of medium voltage multidrives incorporating the latest technology.

## Modular drive for demanding applications

ABB’s ACS 6000 is a modular drive designed for the most demanding single-motor or multi-motor applications. The optimum configuration for each application is reached by combining the modules with minimum engineering effort resulting in lower investment costs and a smaller footprint. It is available with five sizes of inverter modules (3, 5, 7, 9 and 11 MVA).

Several motors can be linked to the ACS 6000 via the common DC bus, enabling multi-machine operation with only one multidrive converter. A multidrive, common DC bus converter principle offers a solution with optimum efficiency.

## Worldwide references

Since its market introduction in 1999, the ACS 6000 has gained an excellent reputation for high quality and reliability.

To date, ABB has installed ACS 6000 medium voltage drives with a total rated power of more than 15,000 MVA.

The ACS 6000 medium voltage drive can be used in a wide range of industries.

## Fields of application

Industries	Applications
Cement, mining and minerals	Mine hoists, conveyors, crushers and mills
Chemical, oil and gas	Pumps, compressors, extruders, mixers and blowers
Marine	Main propulsion, thrusters, pumps and compressors
Metals	Rolling mills, coilers, pumps and fans
Pulp and paper	Fans, pumps, refiners and chippers
Power generation	Fans and pumps
Water	Pump applications, fresh water and waste water
Other applications	Test stands and wind tunnels

# Key features

The ACS 6000 medium voltage drive for speed and torque control of 3 – 27 MW induction or synchronous motors is a member of the ABB AC drives product family. It offers a number of unique key features.

## Powerful performance

Fast and accurate process control in combination with low energy consumption results in top performance. The motor control platform of the ACS 6000 is based on ABB's award-winning Direct Torque Control (DTC) technology. DTC provides the highest torque and speed performance ever achieved in medium voltage drives. As a result, control of the drive is immediate and smooth under all conditions.

## High efficiency and reliability

The ACS 6000 uses a power semiconductor known as IGCT (Integrated Gate Commutated Thyristor), which is an ideal switch for high-powered medium voltage applications. The use of IGCTs results in low parts count, providing an efficient and reliable drive.

## Key product features

- DTC control platform for exceptionally high torque and dynamic performance
- IGCT power semiconductors for high reliability and efficiency
- Line Supply Unit (LSU) for two-quadrant operation with a constant power factor of 0.96 over the whole speed range
- Active Rectifier Unit (ARU) for four-quadrant operation and reduced harmonics, adjustable power factor
- Common DC bus for single and multiple-motor operation and energy recuperation
- Modular design for optimum configurations

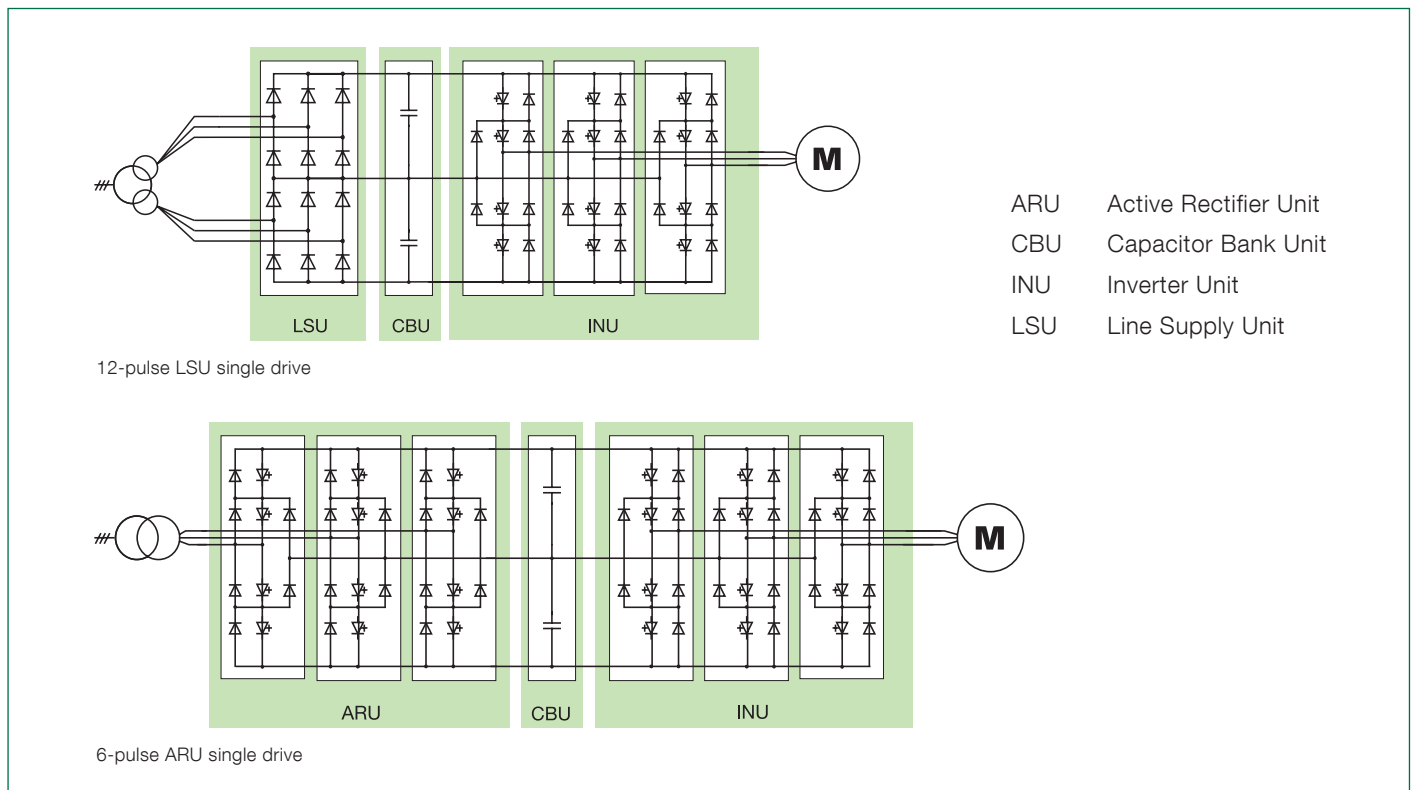

ACS 6000 inverter topology

### High availability

Maximum reliability and short repair time results in a drive with high availability.

### Optimized energy flow

The common DC bus allows several motors to be connected to the same DC bus, providing an optimized energy flow.

The braking energy generated in one motor can be transferred to other inverters via the common DC bus without power consumption from the supply network. Due to the near unity power factor throughout the whole speed range the energy efficiency is optimal.

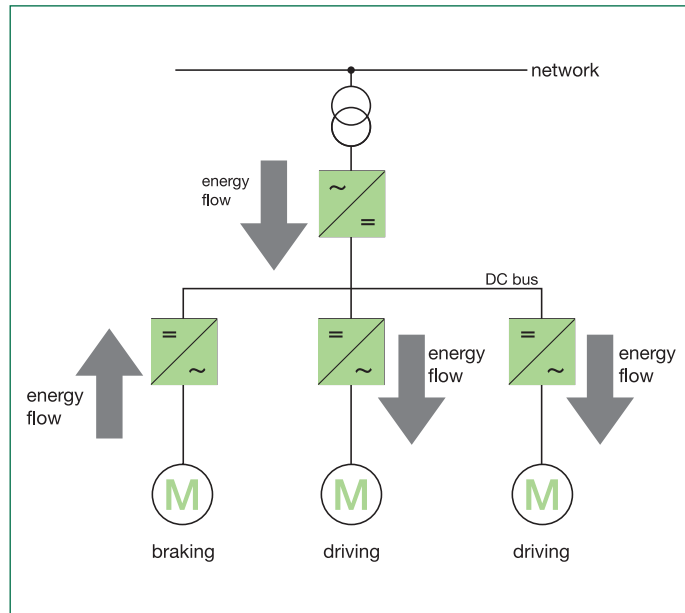

Optimized energy flow with common DC bus e.g. cold reversing steel mill

### ACS 6000 advantages

- High power and maximum reliability
- Smooth torque over the entire speed range
- Applications operate at optimum efficiency
- Compact and high power density
- Low noise and vibration levels
- Minimized energy consumption with common DC bus
- Regeneration of rotating energy

### Flexible

#### Optimum configuration

The modular design of the ACS 6000 allows the optimum configuration of any drive system. Each configuration, consisting of well-proven and certified modules, exactly fits the customer's requirements.

#### Smooth system integration

The ACS 6000 integrates easily into the industrial environment because it can be optimally configured for single-motor and multi-motor applications without additional control equipment. The high power density and compact design and the drive's communication abilities minimize the overall installation and operational costs. The drive can be connected to the network through one or several transformers depending on power and harmonics requirements. A transformerless solution is also available for certain applications.

# ACS 6000 water cooled

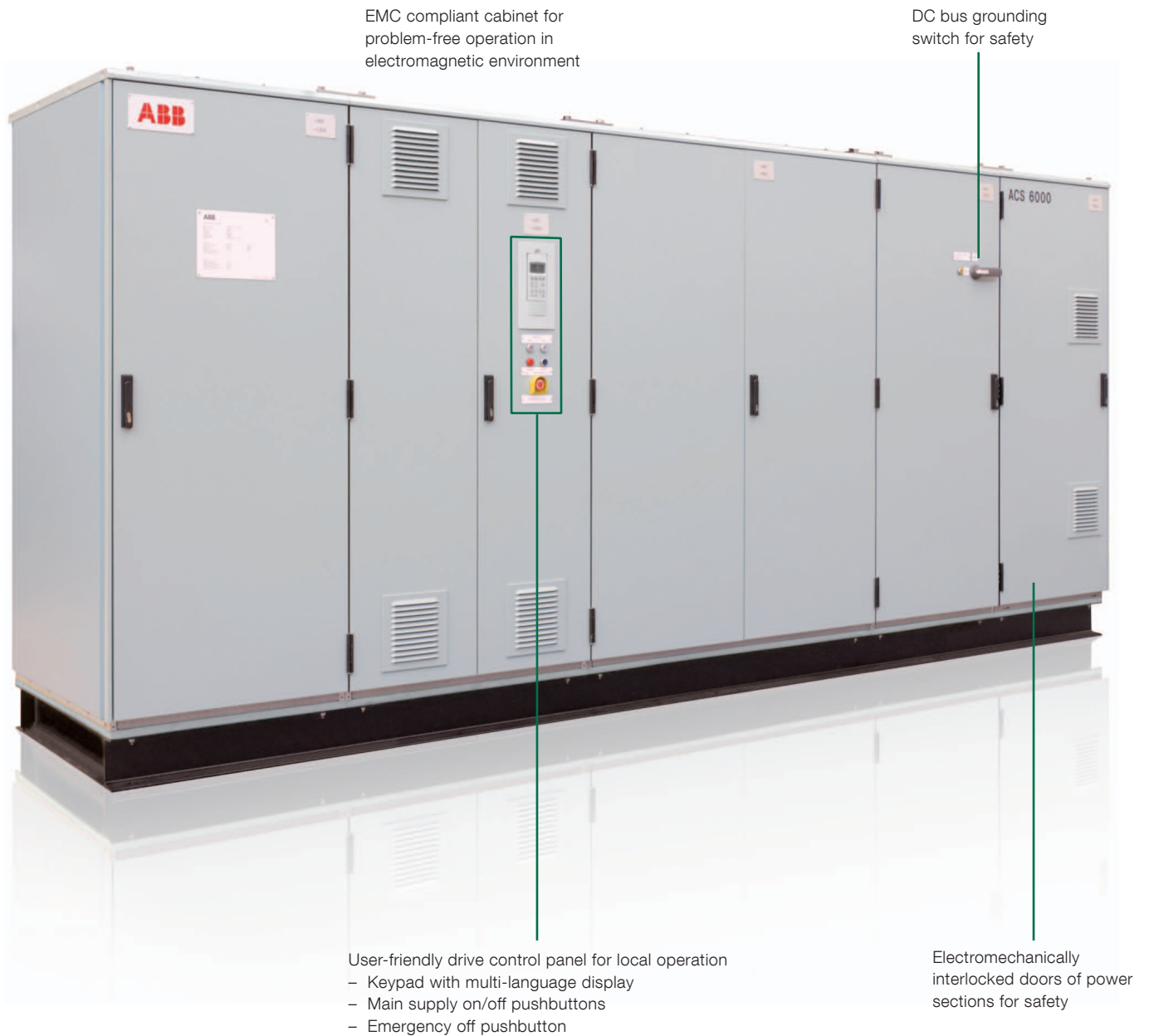

**Power Electronic Building Block (PEBB),**  
one phase leg of a three-level Voltage Source  
Inverter (VSI) topology to be configured to act  
as an AC to DC or DC to AC converter

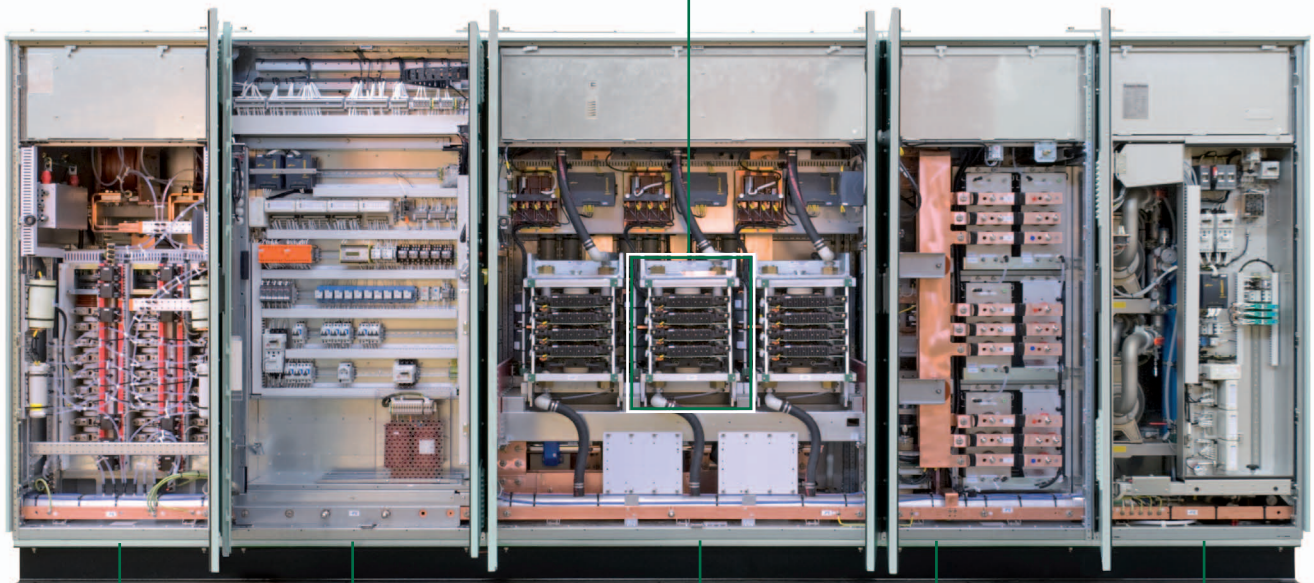
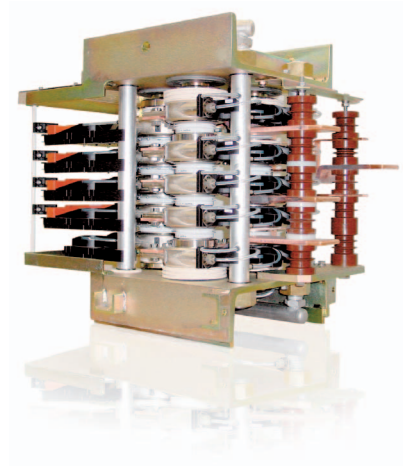

**Line Supply Unit (LSU)**  
Diode rectifier unit

**Terminal Unit (TEU) and  
Control Unit (COU)**  
Contains the power terminals  
and the control swing frame

**Inverter unit (INU)**  
Self-commutated, 6-pulse,  
3-level voltage source inverter  
with IGCT technology

**Capacitor Bank Unit (CBU)**  
DC capacitors for smoothing  
the intermediate DC voltage

**Water Cooling Unit (WCU)**  
Supplies the cooling system  
with deionized water for the  
main power components in  
LSU, INU and CBU

# Technology highlights

Reliability has been the main guiding principle of the research and development activities for ABB's medium voltage AC drives.



## Part count

The fewer the parts the higher the reliability. ABB uses high power semiconductor switching devices and a topology that brings down the part count to a minimum. This results in a reliable, compact and service-friendly drive.

## Fuseless design

The ACS 6000 medium voltage drive is designed to operate safely without fuses, resulting in less spare parts and better overall reliability. This allows fast startup after safety interruptions.

## Encoderless

Encoders are known to cause failures due to their exposed position on the motor. ABB's ACS 6000 medium voltage drive can operate without encoder, thereby reducing maintenance costs and ensuring high levels of availability.

## IGCT semiconductors

The ACS 6000 uses a power semiconductor known as IGCT (Integrated Gate Commutated Thyristor), which is an ideal switch for high-powered medium voltage applications. The use of IGCTs results in low parts count, providing an efficient and reliable drive.

## Low losses

The inherently low total losses of the IGCT require low cooling capacity and small cooling equipment.

## Control

The ACS drive control platform is based on ABB's award-winning Direct Torque Control (DTC), resulting in the highest torque and speed performance as well as lowest losses ever achieved in medium voltage drives. Control of the drive is immediate and smooth under all conditions and the audible noise in the motor is considerably reduced.

## What is Direct Torque Control?

DTC is a revolutionary motor control method for AC drives that allows accurate control of both motor speed and torque without pulse encoder feedback from the motor shaft. In DTC, stator flux and torque are used as primary control variables. The motor state calculations are updated 40,000 times a second (ie, every 25  $\mu$ s) in the advanced motor software model by the high-speed digital signal processor. Due to the continuous updating of the motor state and the comparison of the actual values to the reference values, every single switching in the inverter is determined separately. DTC ensures the absolute lowest losses by switching the power semiconductors only when necessary.

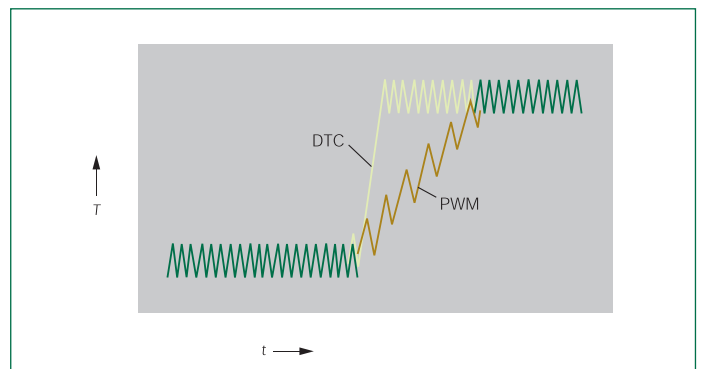

Typical torque (T) response of a DTC drive, compared with flux vector control with open loop Pulse Width Modulation (PWM)

## Fast response to mains fluctuations and process side changes

The exceptionally fast torque step response of the ACS 6000 means that it can respond to process and mains changes extremely fast. This enables easy handling of power-loss situations and sudden load changes.



### Common DC bus

The ACS 6000 modularity is based on the common DC bus converter principle, where several motors (synchronous and induction) can be connected to the same DC bus. With five sizes of inverter modules available (3, 5, 7, 9 and 11 MVA), the optimum configuration for a specific application can be reached by combining the modules with minimum engineering effort. By linking the modules in parallel, the power can be increased to 27 MVA.

Multidrive topologies with a common DC bus offer a solution with optimum efficiency. Energy regenerated from one section in braking mode can be directly used by another section via the DC bus without power consumption from the supply network.

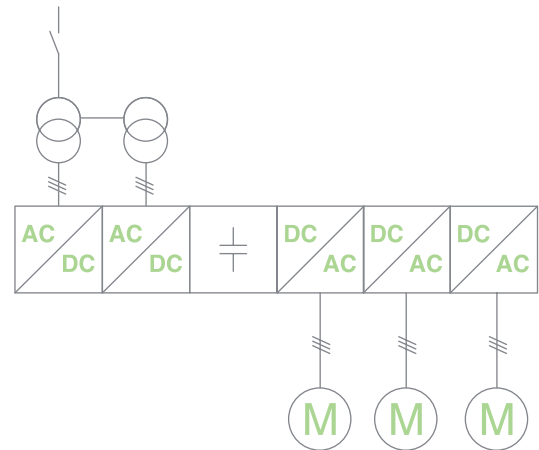

Diagram of common DC bus principle

### ACS 6000 modules

#### Active Rectifier Unit (ARU) , Inverter Unit (INU)

The Active Rectifier Unit (ARU) rectifies the AC line voltage and charges the DC link capacitors whereas the Inverter Unit (INU) inverts the DC voltage to the AC motor voltage.

The layout and equipment of the INU and the ARU are identical. They are self-commutated, 6-pulse, 3-level voltage source inverters, incorporating IGCT technology for a reliable, fuseless operation with a minimum number of drive components.

The ARU allows four-quadrant operation for regenerative braking, which reduces the overall energy consumption. It controls the power factor to unity in the whole operating range even at very low speeds. Optionally the ARU can be dimensioned to compensate reactive power generated by other loads connected to the same network.

#### Line Supply Unit (LSU)

The Line Supply Unit (LSU), designed for two-quadrant operation, maintains the power factor at 0.96 in the whole operating range.

Typically, the LSU is used for applications which only require two-quadrant operation. If short-term braking capability is needed, a Resistor Braking Unit with internal or external resistors can be installed.

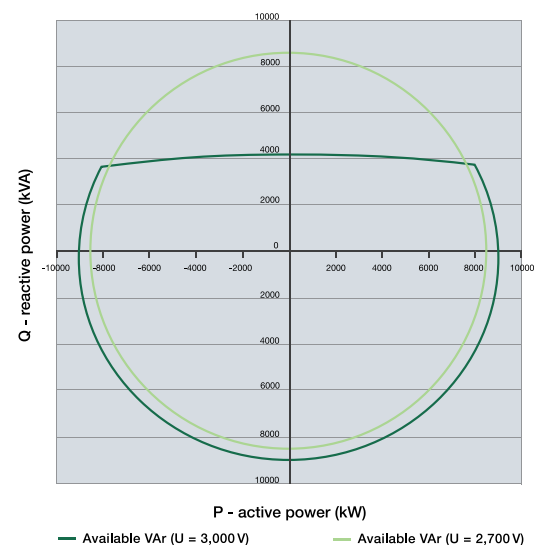

Principle diagram showing the available active and reactive power of the ARU

# Modular use, one design

The ACS 6000 is based on a modular product platform, expanding in line with customer's requirements.

The ACS 6000 is designed as a set of modules. The modules are arranged according to the required output power, motor configuration and process needs.

Depending on the application, the following three basic types of configurations are used:

### Single-motor drive configurations

For synchronous, induction and permanent magnet motors. Single-motor configurations are commonly used in applications which require large, independent and decentralized drives.

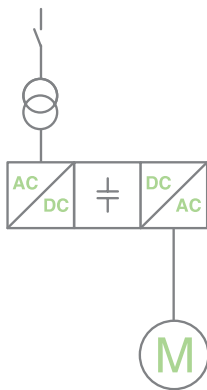

### Redundant drive configurations

For motors with two winding systems. Single drives can be configured to allow various schemes for redundancy offering greater availability of the drive system.

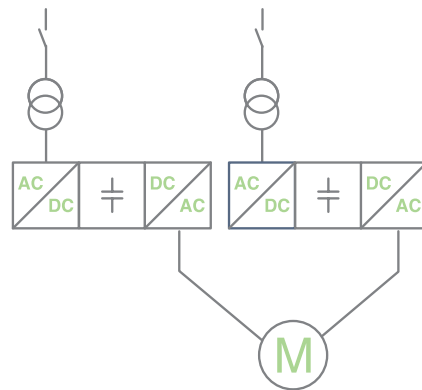

### Multi-motor drive configurations

For multiple synchronous or induction motors or a combination of both types. Up to five motors can be linked to a common DC bus, enabling multiple machine operation. Synchronous and/or induction motors, high or low power, any combination is possible in order to provide the optimum configuration.

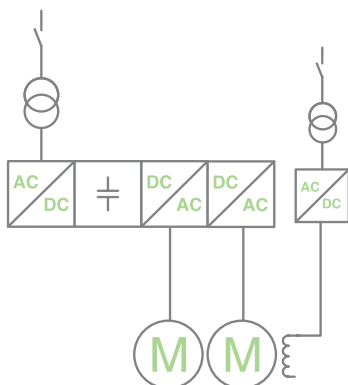

### Benefits of modularity

- Converter rating optimally adapted to customer requirements.
- Each configuration consists of well-proven modules, minimizing the risk of design errors even when extensive systems are engineered.
- The compact, standardized design and the integrated water-cooling system reduce space requirements and have positive impacts on room air conditioning.
- Multidrive topologies with common DC bus are available.
- Reduced installation and commissioning time.

# ACS 6000 for induction or synchronous motors

Depending on the power rating and the application characteristics, the ACS 6000 can be used with induction or synchronous motors.

## ACS 6000 for induction motors

Squirrel cage induction motors are the workhorses of the industry due to their versatility, reliability and simplicity. ABB's broad range of medium voltage AC induction motors includes ribbed cast iron fan cooled motors and modular type welded frame motors.

The ACS 6000 is typically used with induction motors for applications such as pumps, fans, compressors, conveyors, hoists, mills, crushers and propulsion systems.



## ACS 6000 for synchronous motors

Synchronous motors are typically considered for higher power ratings (e.g. above 8 MW to more than 100 MW). In addition to their high power capabilities, synchronous motors offer a wide field weakening range as well as the benefits of high efficiency and high performance.

The ACS 6000 synchronous drive is ideal for applications which require dynamic response and high torque, such as rolling mills and mine hoists and for high power applications, such as marine propulsion drives.

For special applications (e.g. low speed pumps) the ACS 6000 can be used with permanent magnet motors.



# System integration

The ACS 6000 medium voltage drive with its modular concept allows optimum integration into the customer's industrial environment.

The ACS 6000 can either be installed to control just one motor, or to control several motors with comprehensive control features, minimizing overall installation and operational costs. The drive can be supplied by one or several transformers depending on power and harmonics requirements. Even a transformerless solution is available for certain applications.

## Smooth integration into existing systems

### Commissioning

The ACS 6000 is easy to commission. In its multidrive configuration, the ACS 6000 is much faster to commission than the equivalent number of single drives.

### Control system

ABB offers an open communication strategy enabling connection to a PLC (Programmable Logic Controller) or a DCS (Distributed Control System). Fieldbus connectivity with a wide variety of protocols is available.

The ACS 6000 product family platform offers the possibility to monitor the transformers as well as the motors with the drive's control system.

## ACS 6000 system integration

- Low network harmonics
- High power factor in the whole operating range
- Optional reactive power (VAr) compensation
- Small footprint
- Fast commissioning
- EMC compliant

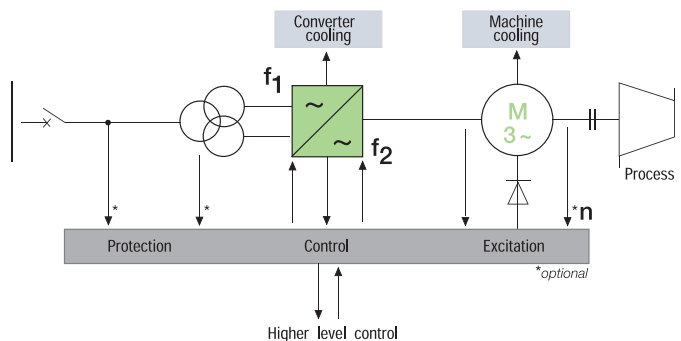

Scope of ACS 6000 system integration

## Applicable standards

The ACS 6000 meets the IEEE 519-1992 and IEC 61000-2-4 specifications for voltage and current harmonic distortion for virtually all installations. This eliminates the need for expensive harmonic filters and protects other electrical equipment from harmonic disturbances.

The ACS 6000 meets EN (IEC), CE, CSA and other standards to ensure smooth system integration worldwide.

# Monitoring and diagnostics

The ACS 6000 is available with an intelligent monitoring and diagnostics system, which allows secure access to the drive from any location in the world.



## Benefits

- Early detection to avoid costly repairs
- Reduction of process-critical faults
- Optimization of maintenance cost and schedule over the product life cycle
- Long-term statistics for optimization of process performance
- Easier root cause analysis – reduced Mean Time To Repair (MTTR)

DriveMonitor™ allows real-time access to the drive. It supports monitoring and diagnostics of ABB drives for new and existing installations.

The optional tool consists of a hardware module inside the drive, as well as a software layer that automatically collects and analyzes selected drive signals and parameters.

Long-term monitoring functions deliver important information on equipment status, maintenance tasks needed and possible performance improvements. As experts can gain access to the drive remotely, DriveMonitor™ also helps cut maintenance costs by reducing on-site work.

With extra diagnostic packages, DriveMonitor™ can also monitor other drive system components, such as main circuit breaker, transformer and the driven machine. Special packages related to the application, such as rolling mills, water pumps and compressors, can be integrated into the system.

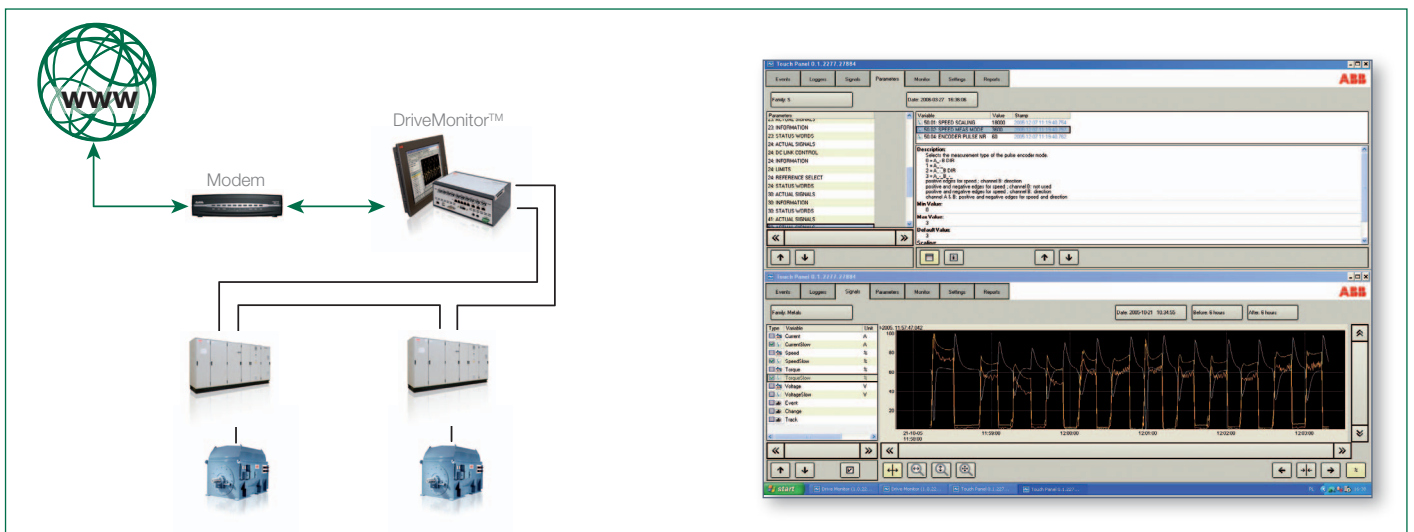

# Testing, service and support

The ACS 6000 is backed by unrivalled service and support from the customer's initial inquiry throughout the entire life cycle of the drive system.

## Testing

ABB is committed to ensuring the reliability of every drive it delivers. To verify that quality standards and customer requirements are fully met every component of a drive is subjected to thorough testing in ABB's modern test facilities.

### ACS 6000 single drive

Tests of the ACS 6000 single drive additionally include load and functional tests on the test field motor.

### ACS 6000 multidrive

The multidrive modules are tested separately one by one as well as in a line-up, where the control functionality of the entire drive system is tested.

### Extended testing

If required ABB also offers the possibility to perform extended testing in ABB's test facilities.

## Installation and commissioning

Proper installation and commissioning, done by qualified and certified commissioning engineers, will reduce start-up time, increase safety and reliability and decrease life-cycle costs. In addition, operators can be given practical training by experienced specialists on site.

## Life-cycle management

ABB's drive life-cycle management model maximizes the value of the equipment and maintenance investment by maintaining high availability, eliminating unplanned repair costs and extending the lifetime of the drive.

Life-cycle management includes:

- providing spare parts and expertise throughout the life cycle
- providing efficient product support and maintenance for improved reliability
- adding functionality to the initial product
- providing a smooth transition to a new technology at the end of the life cycle

## Training

ABB provides extensive training for its medium voltage drives. A range of training programs is offered from basic tutorials to programs tailored to the customer's specific needs.

## Global network, local presence

Aftersales service is an integral part of providing the customer with a reliable and efficient drive system. The ABB Group of companies operates in more than 100 countries and has a worldwide network of service operations.



## Services for ABB's medium voltage drives

- Supervision of installation and commissioning
- Training
- Remote diagnostics
- Customized maintenance contracts
- Local support
- 24 x 365 support line
- Spare parts and logistics network
- Worldwide service network

# Data sheet ACS 6000

Motor data			Converter	Converter data			
Voltage	Shaft power *		Type code	Power	Current	Length***	Weight ***
kV	kW	hp		kVA	A	mm	kg
<b>3,100 V - induction motors - single drives with LSU</b>							
3.1	4300	5800	ACS 6105-L12-1a5	5000	915	4400	3960
3.1	6000	8100	ACS 6107-L12-1a7	7000	1300	4900	4410
3.1	7700	10300	ACS 6109-L12-1a9	9000	1650	4900	4410
3.1	9400	12600	ACS 6114-L12-1a11**	11000	2050	5500	5500
3.1	12000	16100	ACS 6114-L12-2a7	14000	2600	7800	7020
3.1	15400	20600	ACS 6209-L12-2a9	18000	3300	9800	8820
3.1	18000	24100	ACS 6214-L12-2a11**	21000	4100	9800	9800
<b>3,300 V - induction motors - single drives with ARU</b>							
3.3	6000	8000	ACS 6107-A06-1a7	7000	1300	5600	5040
3.3	7700	10300	ACS 6109-A06-1a9	9000	1650	5600	5040
3.3	9400	12600	ACS 6109-A06-1a11**	11000	2050	5600	5600
3.3	12000	16100	ACS 6207-A12-2a7	14000	2600	9900	8910
3.3	15400	20600	ACS 6209-A12-2a9	18000	3300	10300	9270
3.3	18000	24100	ACS 6209-A12-2a11**	21000	4100	10300	10300
3.3	23200	31100	ACS 6309-A18-3a9	27000	4950	17200	15480
<b>3,100 V - synchronous motors - single drives with LSU</b>							
3.1	4800	6400	ACS 6105-L12-1s5	5000	915	5200	4680
3.1	6800	9100	ACS 6107-L12-1s7	7000	1300	5700	5130
3.1	8700	11700	ACS 6109-L12-1s9	9000	1650	5700	5130
3.1	10600	14200	ACS 6114-L12-1s11**	11000	2050	6300	6300
3.1	13500	18100	ACS 6114-L12-2s7	14000	2600	8600	7740
3.1	17400	23300	ACS 6209-L12-2s9	18000	3300	10600	9540
3.1	20300	27200	ACS 6214-L12-2s11**	21000	4100	10600	10600
<b>3,300 V - synchronous motors - single drives with ARU</b>							
3.3	6700	9000	ACS 6107-A06-1s7	7000	1300	6400	5760
3.3	8600	11500	ACS 6109-A06-1s9	9000	1650	6400	5760
3.3	10500	14100	ACS 6109-A06-1s11**	11000	2050	6400	6400
3.3	13400	18000	ACS 6207-A12-2s7	14000	2600	10700	9630
3.3	17200	23000	ACS 6209-A12-2s9	18000	3300	11100	9990
3.3	18000	24100	ACS 6209-A12-2s11**	21000	4100	11100	11100
3.3	25800	34600	ACS 6309-A18-3s9	27000	4950	18000	16200
<b>3,100V - synchronous and induction motors - multidrive examples</b>							
3.1	16500	22100	ACS 6209-L24-1s9-1a9-1a7-1a5-1a3	18000	3300	17100	15390
3.1	8800	11800	- induction motor drive	9000	1650		
3.1	7700	10300	- induction motor drive	9000	1650		
3.1	6000	8000	- induction motor drive	7000	1300		
3.1	4300	5800	- induction motor drive	5000	915		
3.1	2600	3500	- induction motor drive	3000	550		
3.1	17400	23300	ACS 6209-A12-1s9-1s9-1s7-1a5	18000	3300	18300	16470
3.1	10700	14300	- synchronous motor drive	11000	2050		
3.1	8800	11800	- synchronous motor drive	9000	1650		
3.1	6800	9100	- synchronous motor drive	7000	1300		
3.1	4300	5800	- induction motor drive	5000	915		
3.1	26100	35000	ACS 6309-A18-2s9-2s7-1a5	27000	4950	21300	19170
3.1	17600	23600	- synchronous motor drive	18000	3300		
3.1	12000	16100	- induction motor drive	14000	2600		
3.1	4300	5800	- induction motor drive	5000	915		

## Notes:

\* Indicative information: induction motor efficiency 97.5%, power factor 0.88;  
synchronous motor efficiency 97.5%, power factor 1.0.

\*\* 11 MVA INU power is subject to motor design.

\*\*\* Length and weight are approximate values.

# Data sheet ACS 6000

	Line Supply Unit (LSU)	Active Rectifier Unit (ARU)	Input Reactor Unit (Transformerless)
Output power range	Single INU: 3, 5, 7, 9, 11 MVA; Double INU: 14, 18, 22 MVA; Triple/quadruple INU: up to 30 MVA		Single INU: 3, 5, 7, 9 MVA
Main supply voltage (50/60 Hz)	2 x 1725 V (12p) <sup>1</sup> +10/-10% 2 x 1650 V (12p) <sup>2</sup> +15/-5%	3160 V (6p) 3000 V (6p)	3300 V (6p) 3300 V (6p)
Motor voltage (max.)	<sup>1</sup> 3100 V <sup>2</sup> 3000 V	3150 V	3000 V
Input power factor	0.96	1.0 (optional adjustable)	0.98 – 0.95
Output power factor	Induction motor: typically > 0.84; synchronous motor: 1		
Efficiency at rated load including all auxiliaries	> 98.5%	> 97.7%	> 98.5%
External cooling water	Inlet temperature: min. 10°C; max. 32°C (max. 42°C with derating) Pressure: 200 ... 500 kPa (pressure drop approx. 150 kPa)		

## Multidrive with 18 MVA ARU and 9, 7 and 5 MVA INUs

### Dimensions

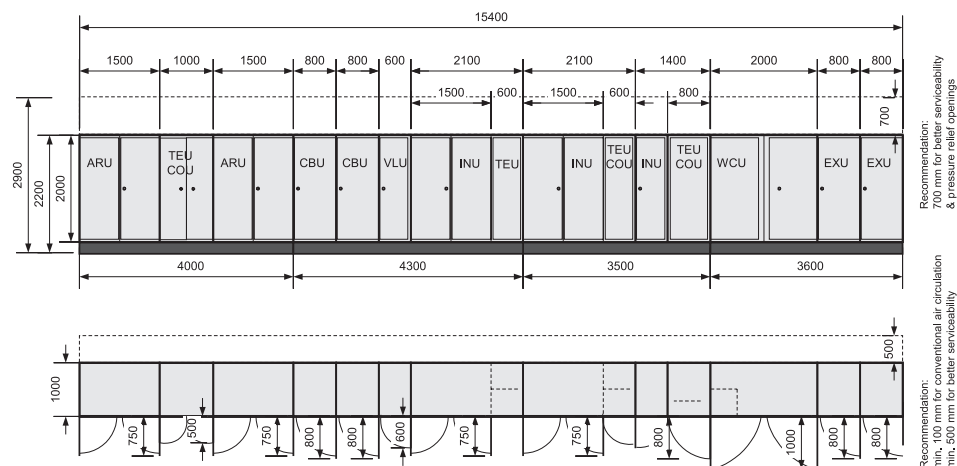

### Single line

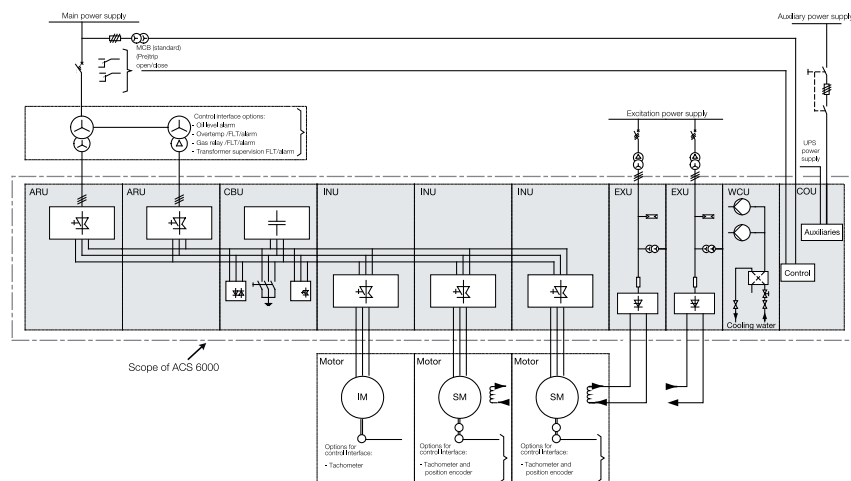

### Definitions

- ARU Active Rectifier Unit
- BCU Braking Chopper Unit
- CBU Capacitor Bank Unit
- COU Control Unit
- EXU Excitation Unit
- IFU Input Filter Unit
- INU Inverter Unit
- IRU Input Reactor Unit
- LSU Line Supply Unit
- RBU Resistor Braking Unit
- TEU Terminal Unit
- VLU Voltage Limiter Unit
- WCU Water Cooling Unit



# Data sheet ACS 6000

## General features

### Inverter type

Voltage Source Inverter Neutral-Point Clamped (VSI-NPC)

### Motors

Induction, synchronous and permanent magnet motors;  
3000 – 27000 kVA water cooled

### Standards

IEC 61800-4, IEC 60146, IEC 60721  
All common standards including EN, IEC, CE  
Marine standards optional

### Input

Medium voltage input transformer for 6, 12 or 24-pulse diode rectifier, 6-pulse ARU  
Variation:  $\pm 10\%$  of nominal voltage, down to  
–25% safe operation with derated output

### Auxiliary voltage

Common 400 – 690 VAC, 3-phase, 50 Hz/60 Hz

### UPS (Uninterruptible Power Supply)

If available, a UPS can be connected for control power supply, 110 – 240 VAC, single phase or 110/220 VDC. Alternatively the drive can be equipped with back-up capacitors (for short term control power-loss ride-through)

### Output frequency

0 to  $\pm 75$  Hz (higher on request)

### Rated output voltage

Standard: 3.0 – 3.3 kV  
Optional: 2.3 kV

### Ambient temperature

+5°C to 45°C (higher with derating)  
31°F to 113°F (higher with derating)

### Enclosure classes

Standard: IP32  
Optional: up to IP54

### Control interface (optional)

All common fieldbuses including Profibus, Modbus, DeviceNet, ABB Advant Fieldbus AF100, others

### Protective functions

Converter:  
Overcurrent, short circuit, earth fault, phase loss, overvoltage, undervoltage, overtemperature, output frequency, network disturbance, cooling supervision  
Motor:  
Overload, underload, stall protection

### Optional

- Motor supervision I/Os
  - Fault/alarm: overtemperature, vibration of bearings
  - PT 100: winding and bearing temperatures
- Transformer supervision I/Os
  - Fault/alarm: overtemperature, overcurrent
  - PT 100: winding temperatures
- Hardwired signals: drive control and drive status indication
  - References: start/stop, speed/torque, etc.
  - Actual feedbacks: ready/running, current/voltage/power, etc.
- Braking chopper
- Classified cabinets according IAC AFLR 20 kA 0.5 seconds

## Maritime properties

### Marine standards

IEC 60092, IEC 60721-3-6, IEC 60068-2-(1,2,6,30,52)  
CE marking according to EU directives

### Marine certification

Available for Lloyd's, DNV, ABS and others

### Braking

0.8 MW (resistor braking unit – internal resistor)  
2.3 MW (braking chopper unit – external resistor)

### Hardware

- Optional inverter output isolator
- Optional customer signal I/Os
- Varnished control boards

### Mechanics

- Vibration dampers
- Maritime handgrips for doors
- Anticondensation heaters
- Locking device for 90° open doors
- Flame-retardant properties
- Halogen-free wiring and cable ducts

### Redundancy

Various redundancy schemes  
(please contact ABB for further information)

# Contact us

**ABB Switzerland Ltd**  
**Medium Voltage Drives**  
CH-5300 Turgi  
Tel.: +41 58 589 27 95  
Fax: +41 58 589 29 84  
E-mail: [mvdrives@ch.abb.com](mailto:mvdrives@ch.abb.com)

[www.abb.com/drives](http://www.abb.com/drives)