

EntelliGuard® G Circuit Breaker Accessories

Ready To Close (RTC)

Introduction

Ready To Close (RTC):

Ready to close switch indicates the breaker readiness status. It indicates when the following conditions are met.

- The circuit breaker is open
- The closing springs are charged
- The circuit breaker is not locked/interlocked in open position
- There is no standing closing order
- There is no standing opening order

The indication can be known either through the trip unit or remotely. RTC thru trip unit is signal rated contact. RTC thru secondary disconnect can be power rated or signal rated. When RTC signal is used thru the secondary disconnect, it replaces the spring charge status contact.



Table 1. Catalog Numbers and Ratings:

RTC TO SD, Signal rated Contact:

			Cat No
AC Ratings	125Vac	0.1A	GRTC2
DC Ratings	30Vdc	0.1A	

	WARNING: Before installing any accessories, turn the breaker OFF, disconnect it from all voltage sources, and discharge the closing springs.
--	---

	AVERTISSEMENT: Avant d'installer tout accessoire, mettre le disjoncteur en position OFF, le déconnecter de toute tension d'alimentation, et décharger les ressorts d'armement
--	--

RTC TO SD, Power Rated Contact:

			Cat No
AC Ratings	125Vac	6A	GRTC1
	250Vac	6A	

RTC TO Trip Unit, Signal rated Contact

			Cat No
AC Ratings	125Vac	0.1A	GRTC3
DC Ratings	30Vdc	0.1A	

Use the following procedure to install the Ready To Close (RTC) accessory into the circuit breaker.

1. Verify that the rating on the Ready To Close (RTC) identification plate matches the voltage rating required for the application, as listed in Table 1.
2. Turn the breaker off and discharge the closing springs by depressing the OFF and ON buttons in the sequence OFF-ON-OFF. Verify that the breaker OFF-ON indicator shows OFF on a green background and that the charge indicator shows

DISCHARGE on a white background. If installing in a draw-out type breaker remove breaker from adaptor (cassette) before continuing.

3. Loosen the 6 screws on front cover (fascia) using a posidrive screw driver as shown in Fig 1.B Rotate the charging handle down and slide the front cover over the handle to remove the front cover as shown in Fig. 1.C.



Figure 1. (A) Front Cover (B) Screw Removal (C) Handle Rotation

4. Slide the RTC switch assembly over the mechanism side sheet and locate in the two locating holes as shown in fig 2.

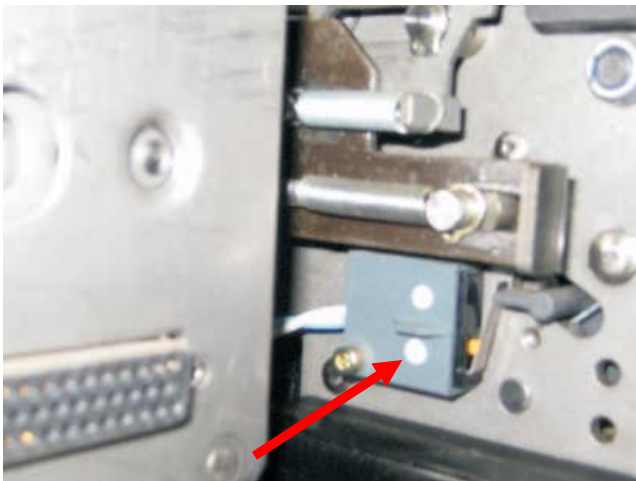

Figure 2. Assembly on mechanism

5. Assemble the screw with washer as shown in Fig. 3 Tighten the screw to torque 1.2Nm (0.9 ft-lbs).

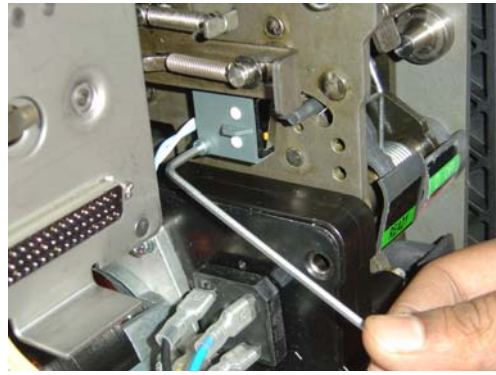

Figure 3. Screw assembly

6. When RTC thru trip unit is used, plug the connector from the RTC switch assembly to the connector marked as RTC from the harness of the trip unit as shown in Fig. 4.

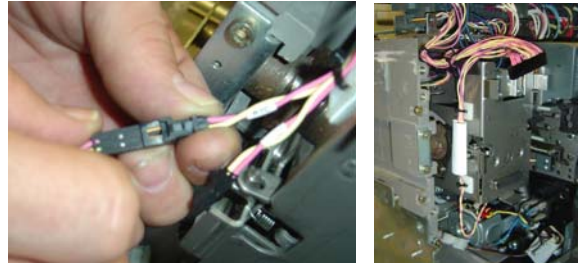

Figure 4. Connector Plug Assembly

7. If RTC is used thru the secondary disconnect, then first unplug the spring charge contact connector from motor as shown in Fig. 5



Figure 5. Unplug Spring Contact

7. Plug the connector from the RTC switch assembly with the plug marked as RTC as shown in fig 6.

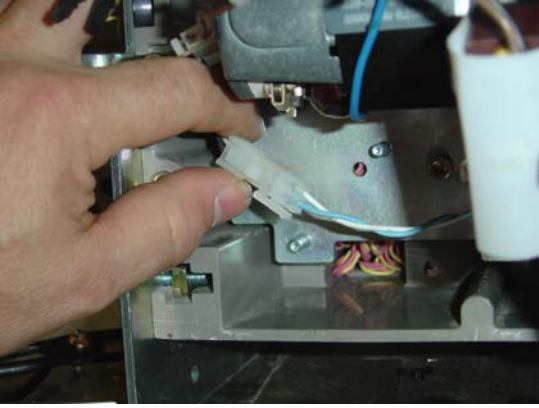

Figure 6. Connector Plug Assembly

8. To reinstall the cover, rotate the charging handle down and slide the front cover over the handle to assemble the front cover to housing as shown in Fig. 7.



Figure 7.

9. Ensure the fascia is aligned properly with the trip unit and the pad lock features of the breaker.

10. Fasten the 6 mounting screws of fascia with the housing using a pozidrive screwdriver. Apply torque of 6 Nm (4.42ft-lbs).

Reference:

Ready To Close (RTC) Connection Scheme:

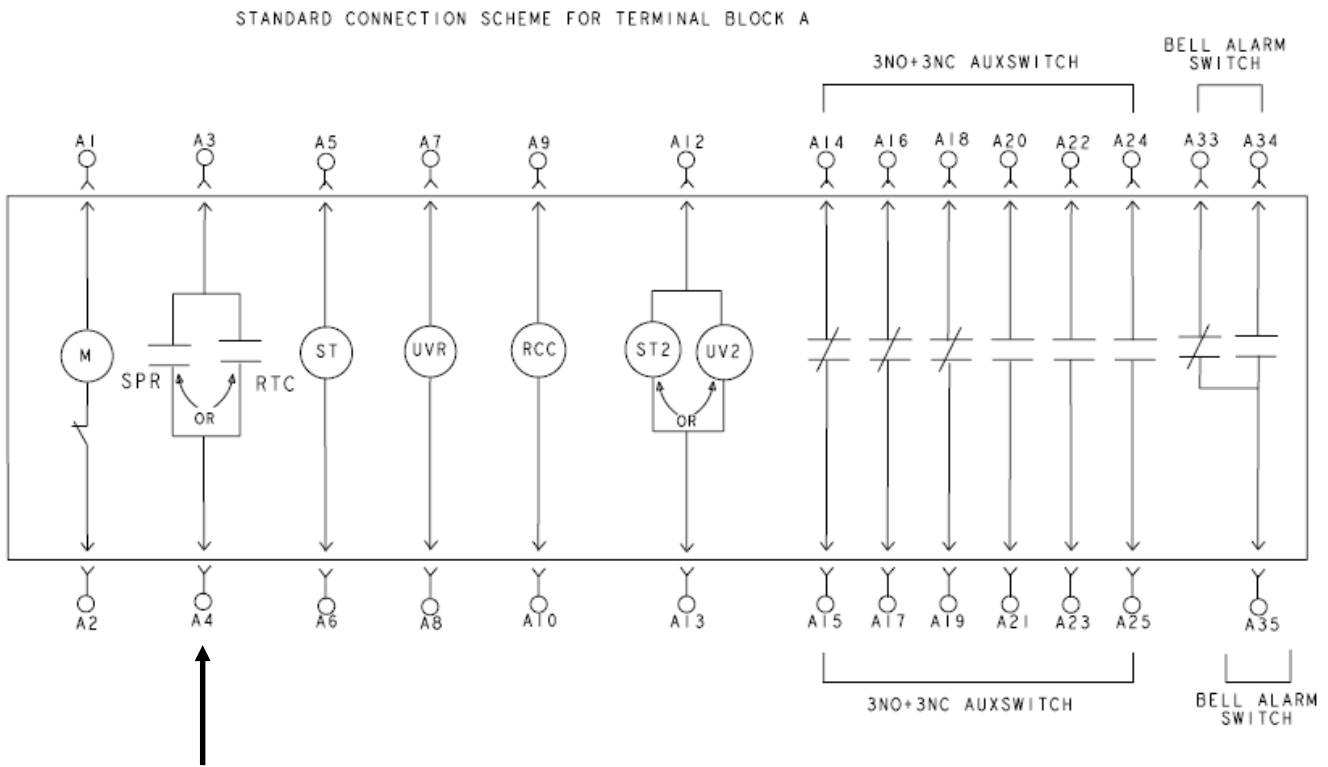

These instructions do not cover all details or variations in equipment nor do they provide for every possible contingency that may be met in connection with installation, operation, or maintenance. Should further information be desired or should particular problems arise that are not covered sufficiently for the purchaser's purposes, the matter should be referred to the ABB Inc.

—
ABB Inc.
 305 Gregson Drive
 Cary, NC 27511.
 electrification.us.abb.com

—
 We reserve the right to make technical changes or modify the contents of this document without prior notice. With regard to purchase orders, the agreed particulars shall prevail. ABB Inc. does not accept any responsibility whatsoever for potential errors or possible lack of information in this document.

We reserve all rights in this document and in the subject matter and illustrations contained therein. Any reproduction or utilization of its contents – in whole or in parts – is forbidden without prior written consent of ABB Inc.
 Copyright© 2019 ABB
 All rights reserved