

# **INSTRUCTION MANUAL**

**MAGNETIC FLOWMETERS**  
**10DX4311 Design Level A**  
**Sizes 6 through 12 Inches**

**COPA-XE™**  
**SERIES 4000 MAGNETIC FLOWMETER**



PN24760B

The following are trademarks of ABB Automation Inc.:

**COPA-XE™**

The following is a registered trademark of Du Pont:

**TEFLON®**  
**TEFZEL®**

The following is a trademark of Haynes International Incorporated:

**HASTELLOY™**

The following is a registered trademark of the HART Communication Foundation:

**HART®**

**WARNING** notices as used in this manual apply to hazards or unsafe practices which could result in personal injury or death.

**CAUTION** notices apply to hazards or unsafe practices which could result in property damage.

**NOTES** highlight procedures and contain information which assist the operator in understanding the information contained in this manual.

All software, including design, appearance, algorithms and source codes, is copyrighted by ABB Automation Inc. and is owned by ABB Automation Inc. or its suppliers.

**WARNING**

**POSSIBLE PROCESS UPSETS**

Maintenance must be performed only by qualified personnel and only after securing equipment controlled by this product. Adjusting or removing this product while it is in the system may upset the process being controlled. Some process upsets may cause injury or damage.

**NOTICE**

The information contained in this document is subject to change without notice.

ABB Automation Inc., its affiliates, employees, and agents, and the authors of and contributors to this publication specifically disclaim all liabilities and warranties, express and implied (including warranties of merchantability and fitness for a particular purpose), for the accuracy, currency, completeness, and/or reliability of the information contained herein and/or for the fitness for any particular use and/or for the performance of any material and/or equipment selected in whole or part with the user of/or in reliance upon information contained herein. Selection of materials and/or equipment is at the sole risk of the user of this publication.

This document contains proprietary information of ABB Automation Inc., and is issued in strict confidence. Its use, or reproduction for use, for the reverse engineering, development or manufacture of hardware or software described herein is prohibited. No part of this document may be photocopied or reproduced without the prior written consent of ABB Automation Inc.

## Table of Contents

<b>Safety Summary</b> . . . . .	<b>I</b>
<b>Read First</b> . . . . .	<b>III</b>
<b>1.0 Introduction</b> . . . . .	<b>1-1</b>
1.1 Operating Principle . . . . .	1-1
1.2 Construction . . . . .	1-1
1.3 Model Number Breakdown . . . . .	1-1
1.3.1 Model 10DX4311 . . . . .	1-2
<b>2.0 Assembly and Installation</b> . . . . .	<b>2-1</b>
2.1 Inspection of Primary . . . . .	2-1
2.2 Installation Requirements . . . . .	2-1
2.2.1 Installation of Primary . . . . .	2-3
2.2.1.1 Gaskets . . . . .	2-3
2.2.1.2 Protective Covers . . . . .	2-3
2.2.1.3 Torque Specifications . . . . .	2-3
2.2.2 Installation in Larger Pipelines . . . . .	2-4
2.3 Electrical Connection . . . . .	2-4
2.3.1 Grounding . . . . .	2-4
2.3.1.1 Grounding Type a) Pipeline . . . . .	2-5
2.3.1.2 Grounding Type b) Pipeline . . . . .	2-5
2.3.1.3 Grounding Type c) Pipeline . . . . .	2-5
2.3.2 Connection to Power Supply . . . . .	2-5
2.3.3 Connection of Input and Output Signals . . . . .	2-6
2.3.4 Conduit Seal & Pressure Relief . . . . .	2-6
2.3.5 Terminal Connection Diagram . . . . .	2-7
2.3.6 Connection Examples For Peripherals . . . . .	2-8
<b>3.0 Maintenance</b> . . . . .	<b>3-1</b>
3.1 Maintenance of Primary . . . . .	3-1
3.2 Maintenance of Converter . . . . .	3-1
3.2.1 General . . . . .	3-1
3.2.2 System Troubleshooting . . . . .	3-2
3.2.3 Static Test . . . . .	3-2
3.2.3.1 Magnet Coil Check . . . . .	3-2
3.2.3.2 Electrode Check . . . . .	3-3
3.2.4 Replacing Converter Electronics . . . . .	3-4
<b>4.0 Parts</b> . . . . .	<b>4-1</b>
4.1 Gaskets . . . . .	4-1
4.2 Grounding Rings . . . . .	4-2
4.3 Protector Plates . . . . .	4-3
4.4 Wiring Entry Seal Parts Kit . . . . .	4-3
4.5 Hardware . . . . .	4-2
4.6 Fuses . . . . .	4-3
4.7 Magnetic Programming Stick . . . . .	4-3
<b>5.0 Start-Up</b> . . . . .	<b>5-1</b>
5.1 Preliminary Check List . . . . .	5-1
5.2 Turn Power On . . . . .	5-1
5.3 Zero Check . . . . .	5-1
5.4 Detector - Empty Pipe . . . . .	5-1
5.5 EEPROM . . . . .	5-1

<b>6.0 Operation: Data Entry and Configuration</b> . . . . .	<b>6-1</b>
6.1 Display Indications . . . . .	6-1
6.2 Data Entry . . . . .	6-2
6.3 Instructions For Entering Data Into the Converter . . . . .	6-3
6.4 Menu Sequence . . . . .	6-4
6.5 Parameter Summary and Data Entry . . . . .	6-5
<b>7.0 Parameter Entry</b> . . . . .	<b>7-1</b>
7.1 Language Tabular Entry . . . . .	7-1
7.2 Submenu "Primary" . . . . .	7-1
7.2.1 Meter Size . . . . .	7-1
7.2.2 Span Cs 7.25 Hz . . . . .	7-1
7.2.3 Zero Cz 7.25 Hz . . . . .	7-2
7.2.4 Short Model Number . . . . .	7-2
7.2.5 Order Number . . . . .	7-2
7.3 Claibration Factor . . . . .	7-2
7.4 Range . . . . .	7-2
7.5 Pulse Factor . . . . .	7-2
7.6 Pulse Width . . . . .	7-3
7.7 Low Flow Cut-Off . . . . .	7-3
7.8 Damping . . . . .	7-4
7.9 Filter (Noise Rejection) . . . . .	7-4
7.10 Density . . . . .	7-4
7.11 System Zero . . . . .	7-4
7.12 Submenu unit . . . . .	7-5
7.12.1 Range Unit . . . . .	7-5
7.12.2 Totalizer Unit . . . . .	7-6
7.12.3 Freely Configurable Unit . . . . .	7-6
7.12.3.1 Unit Factor . . . . .	7-6
7.12.3.2 Unit designation . . . . .	7-6
7.12.3.3 Programmable Unit . . . . .	7-6
7.13 Submenu Alarm . . . . .	7-7
7.13.1 Error log . . . . .	7-7
7.13.2 MAX-Alarm . . . . .	7-7
7.13.3 MIN-Alarm . . . . .	7-8
7.14 Submenu "Prog. In/Output" . . . . .	7-8
7.14.1 Function of Input Terminals X1/G2 . . . . .	7-8
7.14.1.1 Zero Return . . . . .	7-8
7.14.1.2 Totalizer Reset . . . . .	7-8
7.14.1.3 Totalizer Stop . . . . .	7-8
7.14.1.4 No Function . . . . .	7-9
7.14.2 Function of Output Terminals P7/G2 . . . . .	7-9
7.14.2.1 No function . . . . .	7-9
7.14.2.2 F/R-Signal . . . . .	7-9
7.14.2.3 Empty Pipe . . . . .	7-9
7.14.2.4 General Alarm (Error 0 to 7) . . . . .	7-9
7.14.2.5 MAX/MIN-Alarm . . . . .	7-9
7.14.2.6 MIN-Alarm . . . . .	7-10
7.14.2.7 MAX-Alarm . . . . .	7-10
7.15 Submenu "Current Output" . . . . .	7-10
7.15.1 Current Output . . . . .	7-10
7.15.2 Iout At Alarm . . . . .	7-10

7.16 Submenu "Function Test" . . . . .	7-10
7.17 Submenu "Detector Empty Pipe" . . . . .	7-11
7.17.1 Detector On/Off . . . . .	7-11
7.17.2 Alarm Empty Pipe . . . . .	7-12
7.17.3 lout at Empty Pipe . . . . .	7-12
7.17.4 Threshold . . . . .	7-12
7.17.5 Adjustment "Detector Empty Pipe" . . . . .	7-12
7.18 Submenu Totalizer . . . . .	7-12
7.18.1 Forward or Reverse Flow, Totalizer Value Reset, Overflows, Presetting of Totalizer, etc . . . . .	7-12
7.18.2 Totalizer function . . . . .	7-13
7.18.2.1 Totalizer Function Standard . . . . .	7-13
7.18.2.2 Totalizer Function Differential Totalizer . . . . .	7-13
7.19 Submenu Display . . . . .	7-13
7.20 Submenu Operating Mode . . . . .	7-14
7.20.1 Operating Mode . . . . .	7-14
7.20.2 Flow Indication . . . . .	7-14
7.20.3 Flow Direction . . . . .	7-15
7.21 Load Data From External EEPROM . . . . .	7-15
7.22 Store Data In External EEPROM . . . . .	7-15
7.23 Software Version . . . . .	7-15
7.24 Service Code Number . . . . .	7-15
<b>8.0 Block Diagram . . . . .</b>	<b>8-1</b>
<b>9.0 Technical Data . . . . .</b>	<b>9-1</b>
9.1 Meter Size, Pressure Rating, Measuring Range and Flow Rate Nomograph . . . . .	9-1
9.1.1 Flow Rate Nomograph . . . . .	9-1
9.2 Primary Specifications . . . . .	9-2
9.2.1 Enclosure Classification . . . . .	9-2
9.2.2 Mechanical Pipeline Vibration Limits . . . . .	9-2
9.2.3 Explosion Protection . . . . .	9-2
9.3 Converter Specifications . . . . .	9-3
9.3.1 Flow Rate Range . . . . .	9-3
9.3.2 Accuracy . . . . .	9-3
9.3.3 Reproducibility . . . . .	9-3
9.3.4 Minimum Conductivity . . . . .	9-3
9.3.5 Response Time . . . . .	9-3
9.3.6 Power Supply . . . . .	9-3
9.3.7 Magnet Coil Supply . . . . .	9-3
9.3.8 Power Consumption . . . . .	9-3
9.3.9 Ambient Temperature . . . . .	9-4
9.3.10 Electrical Connections . . . . .	9-4
9.3.11 Parameter Entry . . . . .	9-4
9.3.12 Forward/Reverse Flow Measurement . . . . .	9-4
9.3.13 Display . . . . .	9-4
9.3.14 Data Security . . . . .	9-4
9.3.15 Separation of Input / Output . . . . .	9-4
9.3.16 Input / Output Signals . . . . .	9-4
9.3.16.1 Current Output . . . . .	9-4
9.3.16.2 Scaled Pulse Output . . . . .	9-4
9.3.16.3 Contact Output (option) . . . . .	9-5
9.3.16.4 Contact Input (option) . . . . .	9-5
9.3.16.5 Empty Pipe Signalling (option) . . . . .	9-5
9.3.16.6 HART-Protocol (option) . . . . .	9-5

9.3.16.6.1 HART Specifications . . . . .	9-6
9.3.16.6.2 Menu Selection . . . . .	9-6
9.3.16.6.3 Model 275 Menu Sequence . . . . .	9-7
9.3.17 Reference Conditions in Accordance With EN 2994 . . . . .	9-10
9.3.17.1 Fluid Temperature . . . . .	9-10
9.3.17.2 Ambient Temperature . . . . .	9-10
9.3.17.3 Power Supply . . . . .	9-10
9.3.17.4 Installation Conditions of Straight Pipe Section . . . . .	9-10
9.3.17.5 Warm-Up Time . . . . .	9-10
9.3.17.6 Analog Output Influence . . . . .	9-10

## **List of Figures**

Figure 1-1. Basic Magmeter Operating Principle . . . . .	1-1
Figure 2-1. Horizontal Installation . . . . .	2-1
Figure 2-2. Horizontal Mounting Frecautions . . . . .	2-1
Figure 2-3. Vertical Installation . . . . .	2-1
Figure 2-4. Siphon Arrangement . . . . .	2-2
Figure 2-5. Gravity-Feed Pipeline . . . . .	2-2
Figure 2-6. Meter Piping Requirements . . . . .	2-2
Figure 2-7. Contaminated Fluids . . . . .	2-2
Figure 2-8. Vibration Compensation . . . . .	2-3
Figure 2-9. Bolt Tightening Sequence . . . . .	2-3
Figure 2-10. Nomograph For Pressure Loss Calculation . . . . .	2-4
Figure 2-11. Outline Dimensions, ANSI Flanges, 6 through 12 Inches . . . . .	2-5
Figure 2-12. Outline Dimensions, DIN Flanges, 6 through 12 Inches . . . . .	2-6
Figure 2-13. Grounding Type A) Pipeline. . . . .	2-7
Figure 2-14. Grounding Type B) Pipeline . . . . .	2-7
Figure 2-15. Grounding Type C) Pipeline . . . . .	2-7
Figure 2-16. Terminal Housing . . . . .	2-8
Figure 2-17. Cable Entry With Water Trap . . . . .	2-8
Figure 2-18. Conduit Entry Seal Installation . . . . .	2-9
Figure 2-19. Terminal Connection Diagram . . . . .	2-10
Figure 2-20. Connection Examples For Peripherals . . . . .	2-11
Figure 2-21. Standard Interconnection Wiring Diagram . . . . .	2-12
Figure 2-22. Hazardous Area Wiring Diagram . . . . .	2-13
Figure 3-1. New EPROM Module . . . . .	3-2
Figure 3-2. Interface Connectors . . . . .	3-2
Figure 3-3. Electrode Pin Numbers . . . . .	3-3
Figure 3-4. I/O Connector Location . . . . .	3-4
Figure 3-5. Mounting Screws . . . . .	3-4
Figure 3-6. Power Connection . . . . .	3-4
Figure 6-1. Pushbuttons & Converter Display . . . . .	6-2
Figure 8-1. Block Diagram Of Copa-XE . . . . .	8-1
Figure 9-1. Flow Rate Nomograph DN3 To DN300 . . . . .	9-1
Figure 9-2. Fluid Temperature vs. Ambient Temperature . . . . .	9-2
Figure 9-3. Converter Display and Pushbuttons . . . . .	9-3
Figure 9-4. HART Protocol Communication . . . . .	9-6
Figure 9-5. Accuracy Under Reference Conditions . . . . .	9-10

---

## List of Tables

---

Table 2-1.	Torque Rates (DIN) . . . . .	2-3
Table 2-2.	Torque Rates (ANSI) . . . . .	2-4
Table 3-1.	Primary Coil Resistance . . . . .	3-3
Table 4-1.	Flange Gaskets for Meter Body . . . . .	4-1
Table 4-2.	Grounding Rings - Sizes 6 through 12 inches . . . . .	4-2
Table 4-3.	Protector Plates for Teflon & Tefzel Lined Meters - Sizes 6 through 12 inches . . . . .	4-3
Table 6-1.	Errors vs. Priority . . . . .	6-1
Table 9-1.	Meter Sizing & Ratings . . . . .	9-1
Table 9-2.	Pressure Ratings . . . . .	9-2
Table 9-3.	Temperature Ratings . . . . .	9-2
Table 9-4.	Maximum Cleaning Temperature . . . . .	9-2
Table 9-5.	Materials, Wetted Parts . . . . .	9-2
Table 9-6.	Materials, Non-wetted Parts . . . . .	9-3
Table 9-7.	Vacuum Limits . . . . .	9-3
Table 9-8.	Flow Unit Settings . . . . .	9-4
Table 9-9.	Totalizer Units . . . . .	9-4



## SAFETY SUMMARY

---

### GENERAL WARNINGS

#### POSSIBLE PROCESS UPSETS

Maintenance must be performed only by qualified personnel and only after securing equipment controlled by this product. Adjusting or removing this product while it is in the system may upset the process being controlled. Some process upsets may cause injury or damage.

#### RETURN OF EQUIPMENT

All Flowmeters and/or Signal Converters being returned to ABB Instrumentation for repair must be free of any hazardous materials (acids, alkalis, solvents, etc.). A Material Safety Data Sheet (MSDS) for all process liquids must accompany returned equipment. Contact ABB Instrumentation for authorization prior to returning equipment.

#### INSTRUCTION MANUALS

Do not install, maintain or operate this equipment without reading, understanding and following the proper ABB Instrumentation instructions and manuals, otherwise injury or damage may result.

#### ELECTRICAL SHOCK HAZARD

Equipment powered by AC line voltage presents a potential electric shock hazard to the user. Make certain that the system power is disconnected from the operating branch circuit before attempting electrical interconnections or service.

### SPECIFIC WARNINGS

**ELECTRICAL SHOCK HAZARD.** Equipment powered by an ac line voltage presents a potential electric shock hazard. Servicing of the Magnetic Flowmeter or Signal Converter should only be attempted by a qualified electronics technician. (pg. 3-1, 5-1)

Inside edges of the Converter housing casting may be very sharp! Use recommended tools, not fingers, to disconnect plugs from the connectors, otherwise injury might result! (pg. 3-2, 3-4)

**SPECIFIC  
CAUTIONS**

Some of the IC devices used in the signal converter are static sensitive and may be damaged by improper handling. When adjusting or servicing the signal converter, use of a grounded wrist strap is recommended to prevent inadvertant damage to the integral solid state circuitry. (pg. 3-1)

Use care when reconnecting the Converter coild and electrode interface connections to insure that the plugs are in proper alignment with the pins of the headers. If these connections do not mate correctly, the Signal Converter will be inoperable and could be damaged when power is applied. (pg. 3-4)

The "magnetic programming stick" is a very strong magnet. Avoid getting the magnet near any magnetic media (such as floppy disks) since inadvertant data loss may result. (pg. 6-2)

## **GÉNÉRAUX AVERTISSEMENTS**

**PROBLÈMES POTENTIELS.** La maintenance doit être réalisée par du personnel qualifié et seulement après avoir sécurisé les équipements contrôlés par ce produit. L'ajustement ou le démontage de ce produit lorsqu'il est lié au système peut entraîner des dysfonctionnements dans le procédé qu'il contrôle. Ces dysfonctionnements peuvent entraîner des blessures ou des dommages.

**RETOUR D'ÉQUIPEMENT.** Tout débitmètre et(ou) convertisseur retourné à ABB Instrumentation pour réparation doit être exempt de toute trace de produit dangereux (acide, base, solvant, ... ). Un certificat de sécurité matériel doit être joint pour tous les liquides utilisés dans le procédé. Contacter ABB Instrumentation pour autorisation avant renvoi du matériel.

**MANUEL DE MISE EN ROUTE.** Ne pas installer, maintenir ou utiliser cet équipement sans avoir lu, compris et suivi les instructions et manuels de ABB Instrumentation, dans le cas contraire il y a risque d'entraîner blessures ou dommages.

### **RISQUE DE CHOC ÉLECTRIQUE**

Les équipements alimentés en courant alternatif constituent un risque de choc électrique potentiel pour l'utilisateur. Assurez-vous que les câbles d'alimentation amont sont déconnectés avant de procéder à des branchements, des essais ou tests.

## **SPÉCIFIQUES AVERTISSEMENTS**

Risque de choc électrique. Les équipements alimentés en courant alternatif constituent un risque de choc électrique potentiel. La maintenance sur des équipements électromagnétiques ou des convertisseurs doit être effectuée par des techniciens qualifiés. (pg. 3-1, 5-1)

Les bords des boîtiers des convertisseurs sont coupants ! Utiliser les outils recommandés, pas les doigts, pour déconnecter les bornes des connecteurs, autrement vous pourriez vous blesser. (pg. 3-3, 3-4)

**SPÉCIFIQUES  
ATTENTIONS**

Certains Circuits Intégrés utilisés dans le convertisseur sont sensibles à l'électricité statique et peuvent être endommagés par une mauvaise manipulation. Pendant l'ajustement ou la maintenance d'un convertisseur, l'utilisation d'un bracelet antistatique est recommandé pour éviter la destruction par inadvertance d'un circuit intégré. (pg. 3-1)

Prenez garde en remontant les connexions des bobines et des électrodes à ce que les connecteurs soient bien alignés avec les broches des supports. Si ces connecteurs ne sont pas alignés correctement, le convertisseur ne fonctionnera pas et risque d'être endommagé à la mise sous tension. (pg. 3-4)

Le crayon magnétique contient un aimant très puissant. Eviter de le poser près d'un support d'informations magnétique (disquette, carte de crédit... par exemple ) car il pourrait en résulter des pertes de données sur ces supports. (pg. 6-2)

## READ FIRST

---

### WARNING

#### INSTRUCTION MANUALS

**Do not install, maintain, or operate this equipment without reading, understanding and following the proper ABB Instrumentation instructions and manuals, otherwise injury or damage may result.**

#### RETURN OF EQUIPMENT

**All Flowmeters and/or Signal Converters being returned to ABB Instrumentation for repair must be free of any hazardous materials (acids, alkalis, solvents, etc). A Material Safety Data Sheet (MSDS) for all process liquids must accompany returned equipment. Contact ABB Instrumentation for authorization prior to returning equipment.**

**Read these instructions before starting installation;  
save these instructions for future reference.**

The NEMA 4X rating applies to the meter body and electronics enclosure only. The following accessories (if supplied) may not meet NEMA 4X unless specifically ordered as NEMA 4X:

- meter flanges
- meter installation hardware: studs, nuts, bolts
- enclosure mounting hardware for pipe or wall mounting
- conduit hardware

This product is painted with a high performance epoxy paint. The corrosion protection provided by this finish is only effective if the finish is unbroken. It is the users' responsibility to "touch-up" any damage that has occurred to the finish during shipping or installation of the product. Special attention must be given to: meter flange bolting, pipe mounting of electronics, conduit entries and covers that are removed to facilitate installation or repair. For continued corrosion protection throughout the product life, it is the users' responsibility to maintain the product finish. Incidental scratches and other finish damage must be repaired and promptly re-painted with approved touch-up paint. Provide the model number and size of your product to the nearest ABB Instrumentation representative to obtain the correct touch-up paint.

# 1.0 INTRODUCTION

The ABB Instrumentation 10DX4311 magmeter is the ideal flowmeter to meter liquids with a specific minimum electrical conductivity. The flowmeter's accuracy, lack of moving parts and pressure loss and resistance to abrasion and chemical corrosion make it applicable to a variety of applications. The meter installs easily into an existing pipe line. For many years ABB Instrumentation magmeters have been successfully installed in and are the preferred meters in the chemical, pharmaceutical, food, municipal water and waste water industries.

## 1.1 Operating principle

The operating principle of the electromagnetic flowmeter is based on Faraday's law of magnetic induction which states that the voltage induced across any conductor as it moves at right angles through a magnetic field is proportional to the velocity of that conductor (see Figure 1-1 below).

The voltage induced within the fluid is picked up by two diametrically opposed mounted electrodes. The induced signal voltage ( $E_s$ ) is proportional to the magnetic flux density ( $B$ ), the distance between the electrodes ( $D$ ) and the average flow velocity ( $v$ ) of the fluid.

Since the flux density and the electrode spacing are constants, the flow signal is proportional to the average flow velocity of the fluid. Therefore, from the equation for the volumetric flow rate ( $q_v$ ), the flow signal is linearly proportional to the volumetric flow rate.

## 1.2 Construction

This compact design (COPA) is a special arrangement of the magmeter flowmetering system. The converter is integrally-mounted directly on the primary, thereby reducing installation costs.

## 1.3 Model Number Breakdown

The tables on the following pages show the details of the model number composition. Refer to the ABB Instrumentation data sheet or data tag on the equipment for the specific model number of the instrument supplied.

### 1.3.1 Model 10DX4311

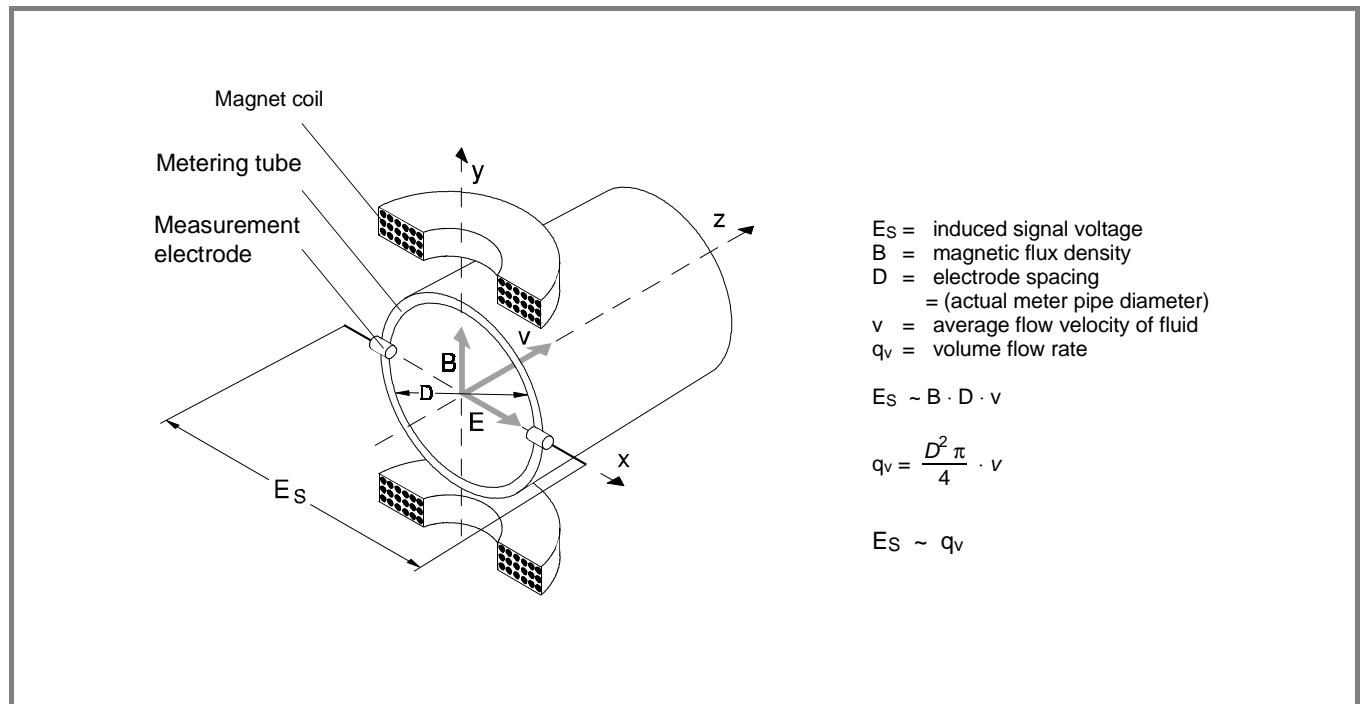

FIG. 1-1. BASIC MAGMETER OPERATING PRINCIPLE

**10DX4311 MAGNETIC FLOWMETER INSTRUCTION BULLETIN**

<b>Order Number</b>	<b>10DX4311</b>	<b>A</b>	-	-	-	-	-	-	-	-	<b>A</b>	-	-	<b>1</b>	-	<b>2</b>	<b>X</b>	<b>3</b>	<b>A</b>	-	-	-	
Conductivity ≥ 20 μS/cm																							
<b>Design Level</b>		<b>A</b>																					
<b>Meter Lay Length</b>																							
Short Form (WMAG)																							
Replacement for 10D1419 & 1465																							
Replacement for 10D1435																							
Other (Refer to Engineering)																							
<b>Liner Material</b>																							
Hard Rubber																							
Soft Natural Rubber (not presently available)																							
Polyurethane																							
PTFE Teflon																							
Neoprene																							
Rotomolded Tefzel																							
<b>Meter Size</b>																							
6 in. (150 mm)																							17
8 in. (200 mm)																							18
10 in. (250 mm)																							19
12 in. (300 mm)																							20
<b>Pressure Rating</b>																							
DIN PN 10																							C
DIN PN 16																							D
DIN PN 25																							E
DIN PN 40																							F
ANSI 150 lb																							P
ANSI 300 lb																							Q
<b>Flange Material</b>																							
Carbon Steel																							1
304 Stainless Steel																							2
<b>Flange Accessories</b>																							
None																							A
Protector Plates, 316 SS																							B
Protector Plates, HAST-C																							C
Protector Plates/Grounding Rings, 316 SS																							D
Protector Plates/Grounding Rings, HAST-C																							E
Grounding Rings, 316 SS																							F
Grounding Rings, HAST-C																							G
Grounding Rings, 304 SS																							H
<b>Electrode Type</b>																							
Flush																							2
Bullet Nose																							3
Flush (Tough Service - Liner Materials "D" or "L" only)																							7

1.3.1 Model 10DX4311 (Cont.)

<b>Order number</b>	10DX4311	A	-	-	-	-	-	-	-	A	-	-	1	-	2	X	3	A	-	-	-
<b>Measurement Electrode Material</b>																					
																					B
316 Stainless Steel																					C
Hastelloy B																					D
Hastelloy C																					E
Titanium																					F
Tantalum (Liner Materials "E" or "N" only)																					H
Platinum / Iridium (Liner Materials "E" or "N" only)																					L
Zirconium																					
<b>Grounding Electrodes</b>																					
None																					A
<b>Certification</b>																					
None																					A
Nonincendive for CI I, Div.2, Gp A,B,C & D: Outdoor Hazardous Locations, NEMA 4X. Dust-Ignitionproof CI II, Div 1, Gp E,F & G: Suitable for CI III, Div.1; Accidental Submergence, 33 ft H <sub>2</sub> O/48 Hr. (10m H <sub>2</sub> O/48 Hr) [Not currently available]																					R
Explosionproof for CI I, Div.1, Gp B,C & D; Dust-Ignitionproof CI II, Div.1, Gp E,F & G; Suitable for CI III, Div.1, Electrodes Intrinsically Safe for CI I, Div.1, Gp A,B,C & D - Outdoor Hazardous Location, NEMA 4X. Accidental Submergence, 33ft H <sub>2</sub> O/48 Hr (10m H <sub>2</sub> O/48 Hr) [Not Currently Available]																					L
<b>Enclosure Classification</b>																					
IEC529 IP65, NEMA 4X																					1
Accidental Submergence: 33 ft H <sub>2</sub> O/48 Hr (10m H <sub>2</sub> O/48 Hr), NEMA 4X (IEC 529 IP67)																					2
<b>Fluid Temperature Range</b>																					
Standard																					1
<b>Excitation Frequency / Line Frequency</b>																					
6 1/4 Hz / 50 Hz Line Frequency																					1
7 1/2 Hz / 60 Hz Line Frequency																					3
<b>Customer Information Language</b>																					
English																					2
<b>Software Level</b>																					
Current Generation																					X
<b>Pulse Output</b>																					
Opto-coupler																					3
<b>Measuring Mode</b>																					
Continuous flow measurement																					A
<b>Accessories</b>																					
None																					A
Empty pipe detection																					B
HART-Protocol																					C
Empty pipe detection + Hart-Protocol																					D
<b>Display Board Options</b>																					
Display illuminated																					B
No display board																					C
<b>Power Supply</b>																					
230/240 VAC; 50/60 Hz																					B
115/120 VAC; 50/60 Hz																					C
48 VAC; 50/60 Hz (not currently available)																					E
24 VAC; 50/60 Hz (not currently available)																					F
24 VDC																					H



## 2.0 ASSEMBLY AND INSTALLATION

### 2.1 Inspection

Before the magmeter is installed, both the primary and converter should be inspected for any damage which may have occurred during shipment. All damage claims should be reported to the shipping agent immediately and before installation of the flowmeter.

### 2.2 Installation Requirements

The electromagnetic flowmeter must be installed in such a way that the meter pipe is always totally filled with fluid and cannot run empty during the measuring procedure. A slight slope of approximately 3% is desirable for assuring this full-pipe condition (See FIGURE 2-1).

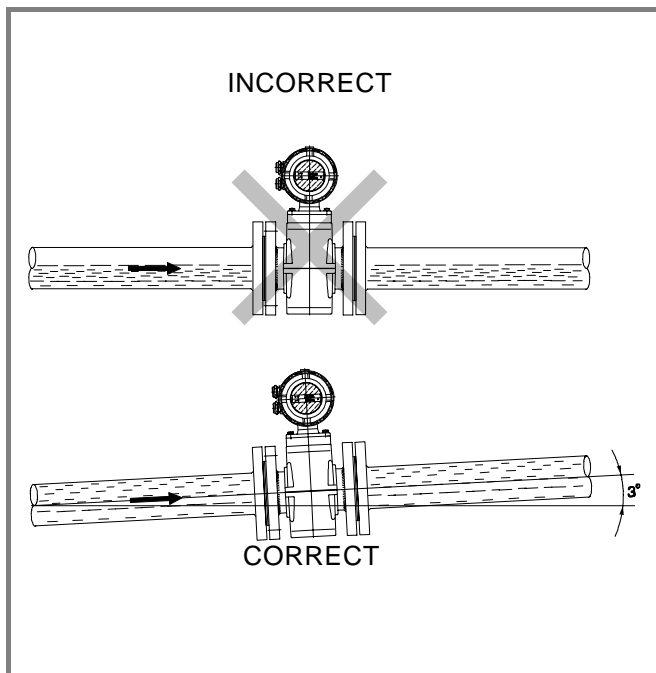

**FIGURE 2-1. HORIZONTAL INSTALLATION**

When installing the flowmeter in a horizontal pipe-line, make sure that an imaginary line (center line) connecting the two electrodes is horizontal so that any trapped gases or air pockets cannot touch the electrodes and cause errors in the flow reading. FIGURE 2-2 shows the desired position of the imaginary connecting line of the electrodes.

By loosening the two screws on the converter base flange, the converter head can be swiveled 90° for better visibility of the instrument's controls and display. Remember to retighten the screws after adjusting the converter head position.

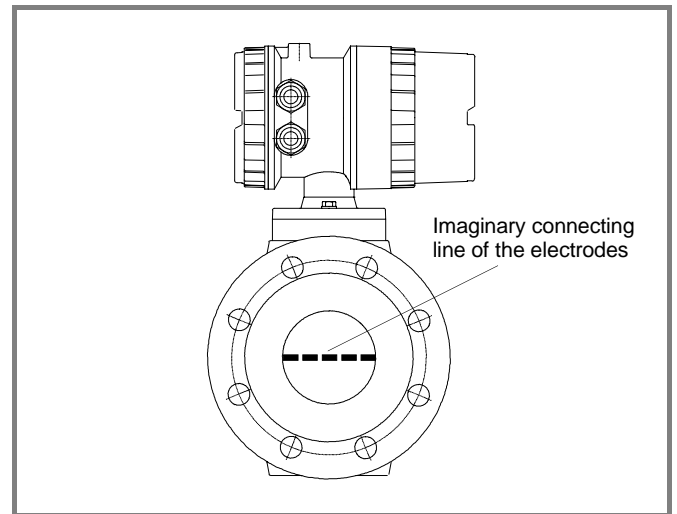

**FIGURE 2-2. HORIZONTAL MOUNTING PRECAUTIONS**

Installation in a vertical pipe line with fluid moving upward (FIGURE 2-3) is the ideal situation. Avoid installation in gravity-feed pipe lines because it has been found that gravity-feed installation does not guarantee a 100% filled meter pipe during measurement. Furthermore, a state of equilibrium can occur between rising gas and the downward flowing fluid.

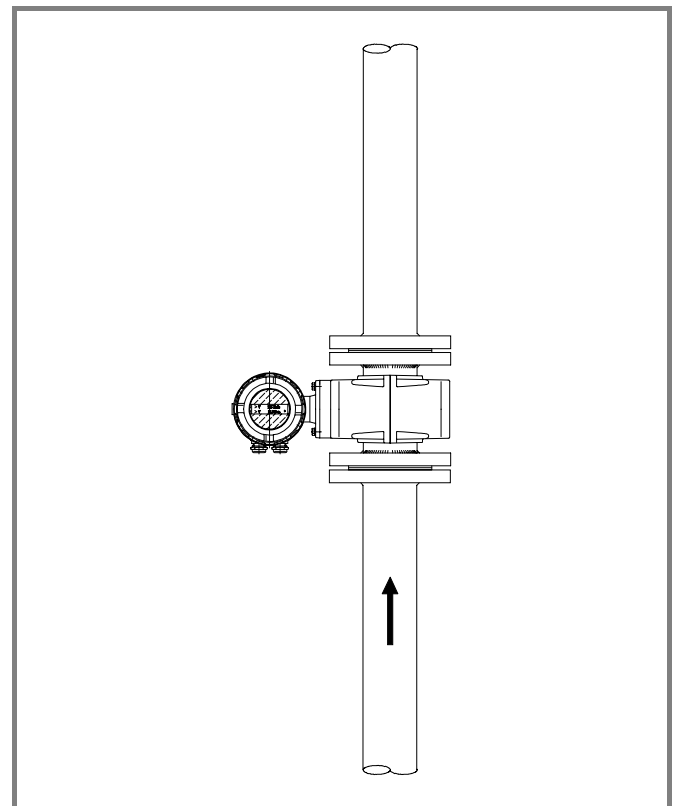

**FIGURE 2-3. VERTICAL INSTALLATION**

A siphon arrangement such as that shown in FIGURE 2-4 should be provided in open-ended systems. This insures that the flowmeter is completely filled with fluid during measurement.

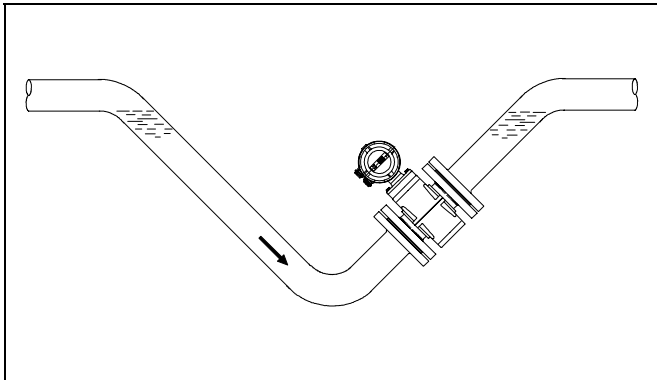

**FIGURE 2-4. SIPHON ARRANGEMENT**

With a free outflow pipe line (gravity feed pipe), the primary should not be installed at the highest point or in the outlet side of the pipeline. These locations may cause the meter to run empty and experience air pockets. See FIGURE 2-5 for correct and incorrect installation in this type of pipeline.

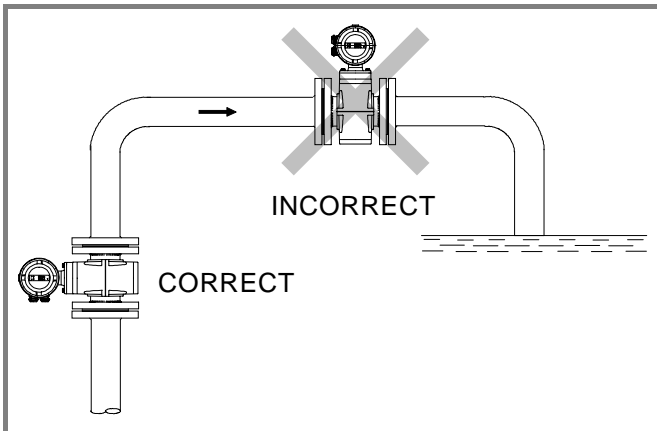
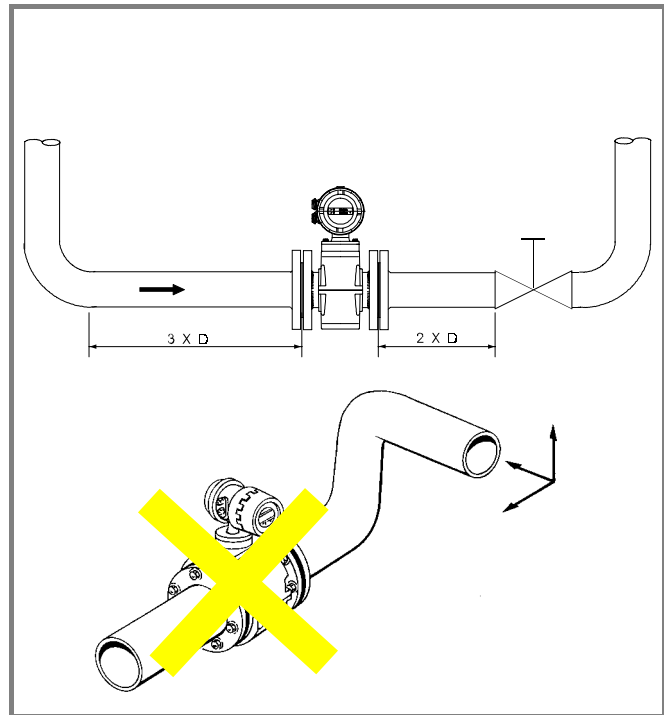

**FIGURE 2-5. GRAVITY-FEED PIPELINE**

The metering principle is independent of the flow profile, as long as standing eddies do not extend into the metering section. For example, the meter should not be installed immediately downstream of elbows, tangential flow entry or partially open butterfly valves. Butterfly or flap valves must be installed in such a manner that the flap does not extend into the primary.

If necessary, measures should be taken to normalize the flow profile. Practice has shown that a straight pipe run of length  $3 \times D$  installed upstream and  $2 \times D$  installed downstream of flowmeter (where  $D$  = nominal meter ID) is sufficient to normalize the flow profile. See FIGURE 2-6.

When using the magmeter as a reference flow standard, a  $10 \times D$  straight pipe run upstream and a  $5 \times D$  straight pipe run downstream of primary must be installed.



**FIGURE 2-6. METER PIPING REQUIREMENTS**

For highly contaminated liquids a by-pass as shown in FIGURE 2-7A is recommended. Version A allows cleaning of the flowmeter during operation.

In some cases the fluid's contamination deposits on the electrodes and causes the electrodes to become insulated from the fluid. In these situations, FIGURE 2-7B is recommended.

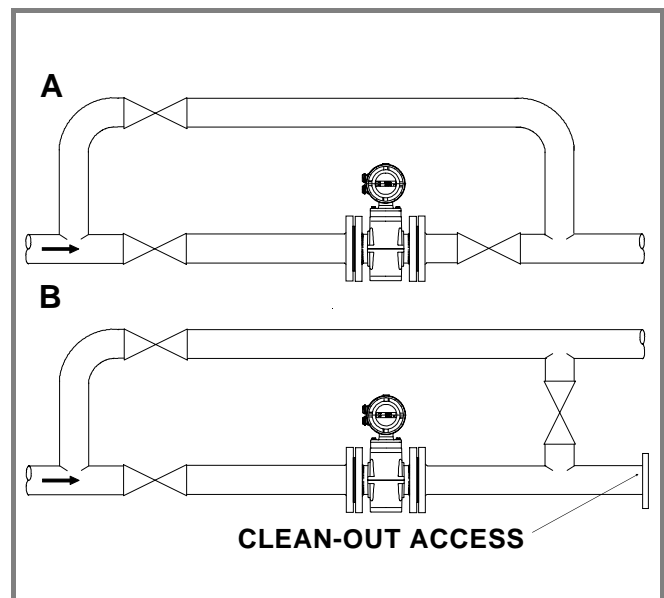

**FIGURE 2-7. CONTAMINATED FLUIDS**

If primaries are installed close to pumps or other devices that may cause vibration, the application of mechanical vibration dampening devices is recommended (FIGURE 2-8).

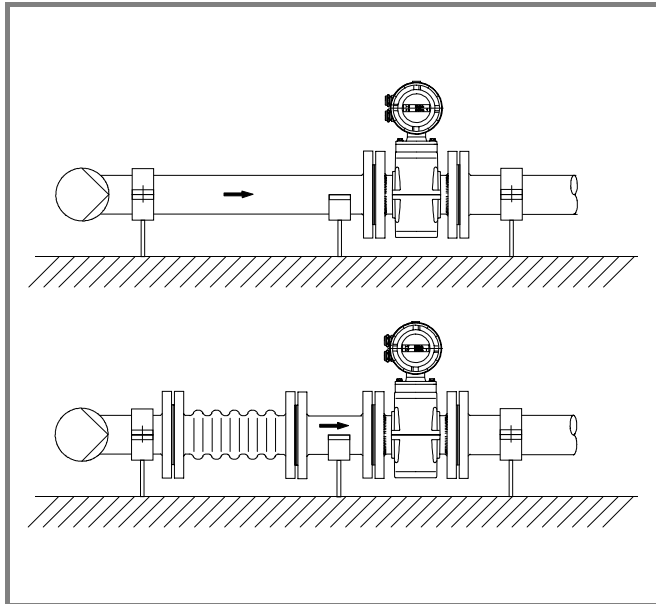

FIGURE 2-8. VIBRATION COMPENSATION

### 2.2.1 Installation of Primary

The electromagnetic flowmeter can be installed at any arbitrary location in the pipeline as long as the installation requirements of Section 2.2 are observed.

Select the installation site so that moisture cannot leak into the terminal or signal converter housing. Also make sure that gaskets are seated properly and to install the cover carefully after meter installation and start-up.

#### 2.2.1.1 Gaskets

Use only the gaskets supplied with the instrument. Using the proper gaskets and installing them correctly will avoid any possibility of leakage. Observe information given on page 4-1.

**NOTE**

**Do not use graphite gaskets.** Under certain conditions they may cause an electrically conductive layer to form on the inside wall of the meter, causing meter operation to degrade.

#### 2.2.1.2 Protective Covers

The protective covers provide protection for the liner. Keep the protective covers in place until the primary is actually ready for installation. Be careful not to damage the liner with the mating flanges to avoid potential leaks. The outline dimensions for specific

meters are shown in Technical Data section 10.0 on pages 10-7 & 10-8 .

### 2.2.1.3 Torque Specifications

To avoid localized stresses on the gaskets, tighten the flange bolts in a "star" pattern as shown in FIGURE 2-9 for 4-bolt and 8-bolt flanges. Use a similar method for 10 & 12-bolt flanges. It is recommended that the bolts and nuts be lubricated and tightened using a torque wrench. The bolts and nuts should be tightened to approximately 50% of the torque value during the first pass, to approximately 80% during the second pass and to the full torque during the third pass. The maximum torque rate values shown in TABLES 2-1 & 2-2 must **not** be exceeded.

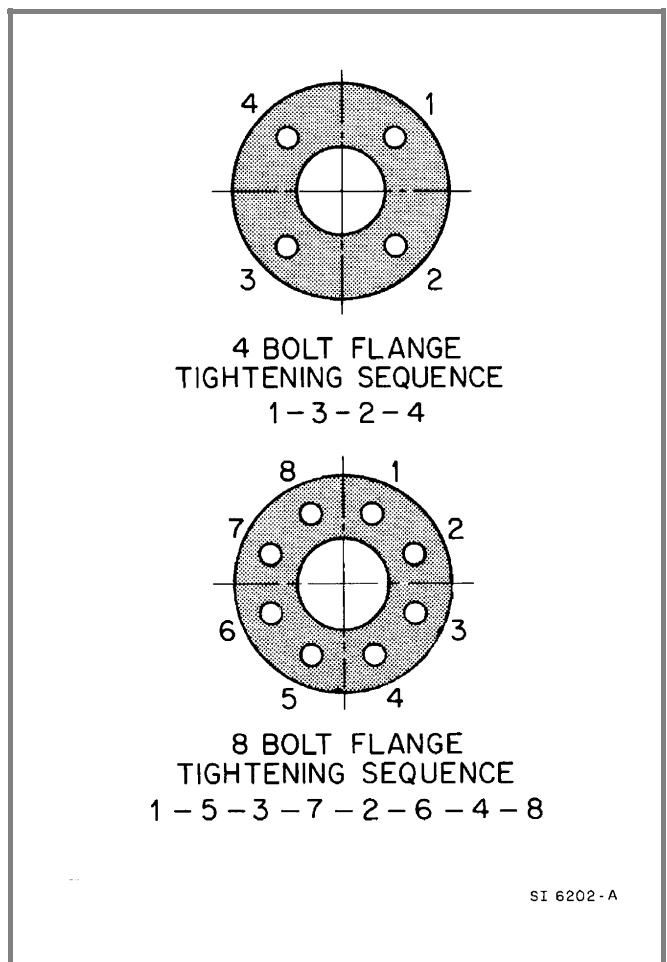

FIGURE 2-9. BOLT TIGHTENING SEQUENCE

TABLE 2-1 - Torque Recommendations (DIN)

Liner Material	Size		Bolt No. & Size	Max. Torque Rate		PN bar
	in.	mm		ft-lb	Nm	
PFA ≤ DN 250	6	150	8 x M20	60.8	82.5	16
	8	200	12 x M20	59.7	81.0	16
PTFE/ Hard rubber	10	250	12 x M24	88.5	120.0	16
	12	300	12 x M24	118.0	160.0	16

**TABLE 2-2- Torque Recommendations (ANSI)**

Liner Material	Size in. mm		ANSI Class 150		ANSI Class 300	
			Bolt No. & Size (in.)	Max. Torque Rate (ft-lb)	Bolt No. & Size (in.)	Max. Torque Rate (ft-lb)
PTFE / TEFZEL / Hard Rubber	6	150	8 x 3/4	60	12 x 3/4	40
	8	200	"	75	12 x 7/8	60
	10	250	12 x 7/8	70	16 x 1	65
	12	300	"	95	16 x 1 1/8	95

**2.2.2 Primary Outline Dimensions**

Outline dimensions of the flowmeter are given in Figures 2-11 & 2-12.

**NOTE**

When using grounding rings and gaskets, add 1/8 inch per end (1/4 inch total) to the overall meter installation length (dimension "L" in Figures 2-11 & 2-12) to allow for the added thickness of these items.

The installation site must be provided with a convenient source of power as specified for the Signal Converter. The power line should have a disconnect switch and a suitable fuse or circuit breaker as indicated in the interconnection diagrams shown in Figures 2-23 & 2-24.

**2.2.3 Installation in Larger Pipelines**

The primary can be fitted in pipelines of larger diameters using double flanged pipe reducers. The resulting pressure losses can be determined from the nomograph in FIGURE 2-10. The procedure to determine the pressure loss is as follows:

- 1) Calculate the diameter ratio d/D.
- 2) Determine the flow velocity v for the meter size and the flow rate

$$v = \frac{Q \text{ (instantaneous flow)}}{\text{meter constant}}$$

The flow velocity can also be determined from the flow rate nomograph in Figure 9-1.

- 3) Read the pressure loss from the intersection of the d/D ratio and the velocity curve in Figure 2-10.

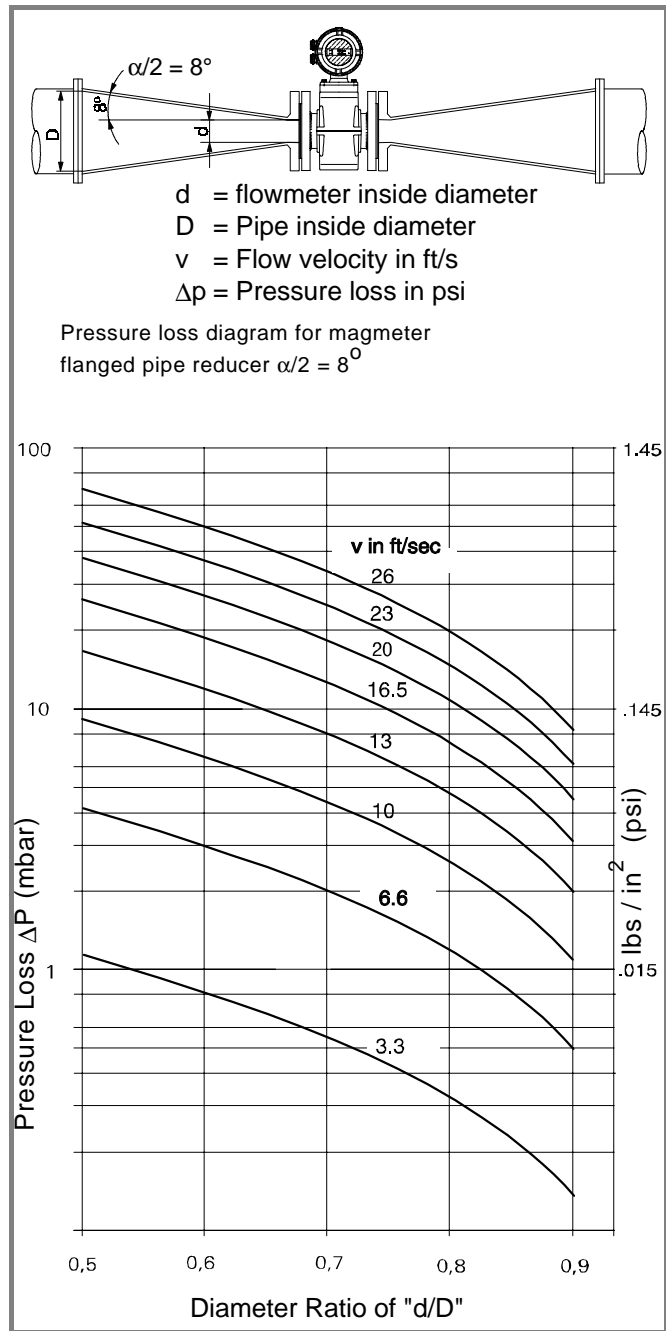

**FIGURE 2-10. NOMOGRAPH FOR PRESSURE LOSS CALCULATION**

**NOTES**

- 1) ALL DIMENSIONS ARE IN INCHES. DIMENSIONS IN PARENTHESIS [ ] ARE IN MILLIMETERS [mm].
- 2) DIMENSIONS ARE GUARANTEED ONLY IF THIS PRINT IS CERTIFIED.
- 3) THIS DRAWING IS A THIRD ANGLE PROJECTION AS SHOWN. 
- 4) FLANGE BOLT HOLES STRADDLE CENTERLINES
- 5) FLOW MUST BE IN SAME DIRECTION AS FLOW ARROW.
- 6) METER MUST BE COMPLETELY FILLED WITH LIQUID TO INSURE ACCURACY.
- 7) ALL DIMENSIONS SUBJECT TO MANUFACTURING TOLERANCES OF  $\pm 1/8(3)$ .

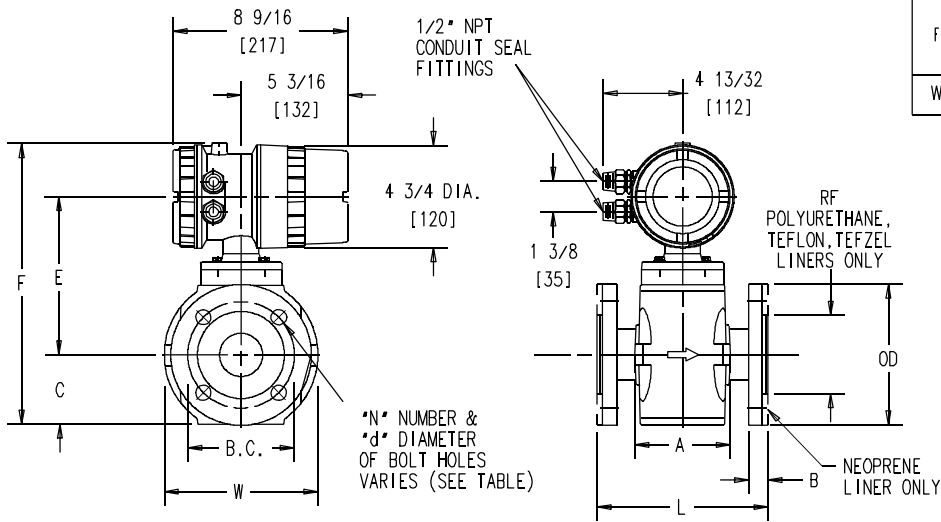

		OUTLINE DIMENSIONS inches (mm)							
DIM	SIZE	6 (150)		8 (200)		10 (250)		12 (300)	
	ANSI FLG CL	150	300	150	300	150	300	150	300
MODEL NO.									
L	10DX4311_D	11-13/16 (300)		13-25/32 (350)		17-23/32 (450)		19-11/16 (500)	
	10DX4311_E	17-23/32 (450)		19-11/16 (500)		21-21/32 (550)		24-13/32 (620)	
	10DX4311_F	NA		NA		NA		18 (457)	
LINER									
RF	NEOPRENE	NA	NA	NA	NA	NA	NA	NA	NA
RF	OTHERS	8-1/2 (216)		10-5/8 (270)		12-3/4 (324)		15 (381)	
B	POLY/NEOP	1-3/16 (30)	1-5/8 (41)	1-5/16 (33)	1-13/16 (46)	1-3/8 (35)	2-1/16 (52)	1-1/2 (38)	2-1/4 (57)
	TEFLON	1-1/8 (29)	1-9/16 (40)	1-9/32 (32)	1-25/32 (44)	1-3/8 (35)	2-1/16 (52)	1-1/2 (38)	2-1/4 (57)
	TEFZEL	1-1/8 (29)	1-9/16 (40)	1-1/4 (32)	1-3/4 (44)	1-5/16 (33)	2 (51)	1-25/64 (35)	2-9/64 (54)
d		7/8 (22)	7/8 (22)	7/8 (22)	1 (25)	1 (25)	1-1/8 (29)	1 (25)	1-1/8 (29)
N		8	12	8	12	12	16	12	16
BC		9-1/2 (241)	10-5/8 (270)	11-3/4 (298)	13 (330)	14-1/4 (362)	15-1/4 (387)	17 (432)	17-3/4 (451)
OD		11 (279)	12-1/2 (318)	13-1/2 (343)	15 (381)	16 (406)	17-1/2 (445)	19 (483)	20-1/2 (521)
A		6-11/16 (170)		7-11/16 (195)		9-27/32 (250)		9-27/32 (250)	
C		5-25/32 (147)		7-1/16 (179)		8-5/32 (207)		9-27/32 (250)	
E		9-7/8 (251)		11-3/32 (282)		12-3/16 (310)		13-7/8 (353)	
	DIV 1 ONLY	10-5/8 (270)		11-27/32 (301)		12-15/16 (329)		14-5/8 (372)	
F		18-5/32 (461)		20-19/32 (523)		22-25/32 (579)		26-3/16 (665)	
	DIV 1 ONLY	18-29/32 (480)		21-11/32 (542)		23-17/32 (598)		26-15/16 (684)	
W		12-3/16 (310)		14-3/8 (365)		16-25/32 (426)		20-5/64 (510)	

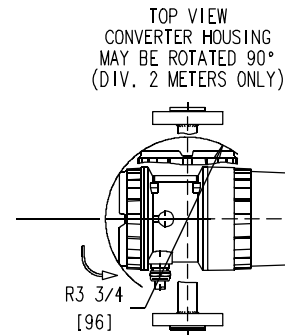

10d4207r1

**FIGURE 2-11. ANSI FLANGES, SIZES 6 THROUGH 12 INCHES**

OUTLINE DIMENSIONS inches (mm)															
DIM	SIZE DIN PN	6 (150)		8 (200)				10 (250)				12 (300)			
		10/16	25/40	10	16	25	40	10	16	25	40	10	16	25	40
MODEL NO.															
L	10DX43111.D	11-13/16 (300)		13-25/32 (350)				17-23/32 (450)				19-11/16 (500)			
L	10DX43111.E	17-23/32 (450)		19-11/16 (500)				21-21/32 (550)				24-13/32 (620)			
LINER															
RF	NEOPRENE	NA		NA				NA				NA			
RF	OTHERS	8-11/32 (212)	8-19/32 (218)	10-9/16 (268)	10-15/16 (278)	11-7/32 (285)		12-19/32 (320)	13-3/16 (335)	13-19/32 (345)		14-9/16 (370)	14-7/8 (378)	15-9/16 (395)	16-5/32 (410)
B	POLY/NEOP	1-3/16 (30)	1-5/8 (41)	1-3/8 (35)		1-7/8 (48)		1-7/16 (36)		2-1/8 (54)		1-1/2 (38)		2-1/4 (57)	
B	TEFL	1-1/8 (29)	1-9/16 (40)	1-9/32 (33)		1-25/32 (45)		1-3/8 (35)		2-1/16 (52)		1-1/2 (38)		2-1/4 (57)	
	TEFZ	1-1/8 (29)	1-9/16 (40)	1-1/4 (32)		1-3/4 (44)		1-5/16 (33)		2 (51)		1-25/64 (35)		2-9/64 (54)	
d		7/8 (22)	1-1/32 (26)	7/8 (22)	1-1/32 (26)	1-3/16 (30)		7/8 (22)	1-1/32 (26)	1-3/16 (30)	1-5/16 (33)	7/8 (22)	1-1/32 (26)	1-3/16 (30)	1-5/16 (33)
N		8		8		12		12				12			
BC		9-1/2 (240)	9-27/32 (250)	11-5/8 (295)	12-7/32 (310)	12-19/32 (320)		13-25/32 (350)	13-31/32 (355)	14-9/16 (370)	15-5/32 (385)	15-3/4 (400)	16-9/16 (410)	16-15/16 (430)	17-23/32 (450)
OD		11-7/32 (285)	11-13/16 (300)	13-3/8 (340)	14-3/16 (360)	14-3/4 (375)		15-9/16 (395)	15-15/16 (405)	16-23/32 (425)	17-23/32 (450)	17-17/32 (445)	18-1/8 (460)	19-3/32 (485)	20-9/32 (515)
A		6-11/16 (170)		7-11/16 (195)				9-27/32 (250)				9-27/32 (250)			
C		5-25/32 (147)		7-1/16 (179)				8-5/32 (207)				9-27/32 (250)			
E		9-7/8 (251)		11-3/32 (282)				12-3/16 (310)				13-7/8 (353)			
F		18-5/32 (461)		20-19/32 (523)				22-25/32 (579)				26-3/16 (665)			
W		12-3/16 (310)		14-3/8 (365)				16-25/32 (426)				20-5/64 (510)			

NOTES

- 1) ALL DIMENSIONS ARE IN INCHES. DIMENSIONS IN PARENTHESIS [ ] ARE IN MILLIMETERS (mm).
- 2) DIMENSIONS ARE GUARANTEED ONLY IF THIS PRINT IS CERTIFIED.
- 3) THIS DRAWING IS A THIRD ANGLE PROJECTION AS SHOWN.
- 4) FLANGE BOLT HOLES STRADDLE CENTERLINES
- 5) FLOW MUST BE IN SAME DIRECTION AS FLOW ARROW.
- 6) METER MUST BE COMPLETELY FILLED WITH LIQUID TO INSURE ACCURACY.
- 7) ALL DIMENSIONS SUBJECT TO MANUFACTURING TOLERANCES OF ±1/8(3).

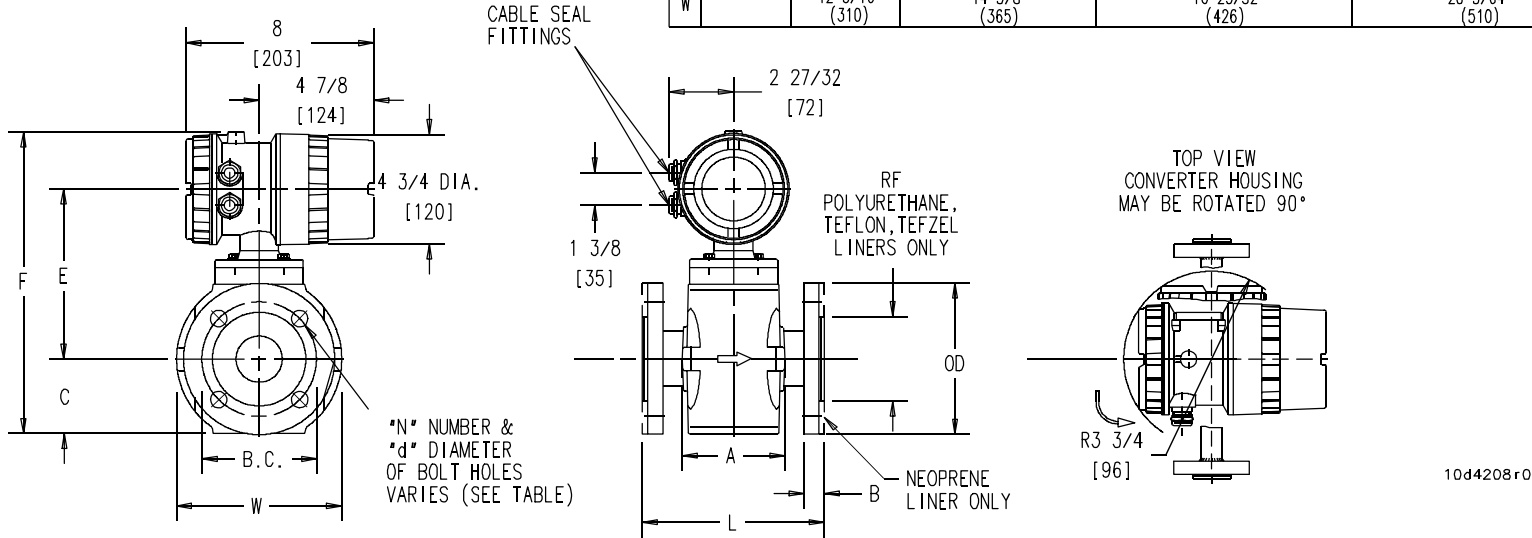

FIGURE 2-12. DIN FLANGES, SIZES 6 THROUGH 12 IN.

## 2.3 Electrical Connection

### 2.3.1 Grounding

Proper grounding of the electromagnetic flowmeter is important for correct functioning as well as for safety reasons.

For grounding purposes, an AWG#10 (or heavier) copper wire must be connected between one of the grounding screws (on either the flange or housing) to the protective ground. For accurate flow measurement fluid and pipeline should be at normal ground potential. Additional grounding by way of terminals is not necessary.

The following different type pipelines must be considered for proper grounding procedures:

- a) Metal pipe
- b) Metal pipe with loose flanges.
- c) Plastic, stoneware, or piping with insulating liner.

With design a) and b) fluid is in electrical contact with piping. With design c) fluid is not in electrical contact with piping system.

#### 2.3.1.1 Grounding Type a) Pipeline

Drill and tap one blind hole (M6 or 1/4" dia.) into the peripheral surface of pipeline flanges next to the grounding wire or grounding terminal of primary. With machine screw, spring and flat washers and an additional 10AWG grounding wire, connect primary with pipeline and protective ground potential as shown in FIGURE 2-13.

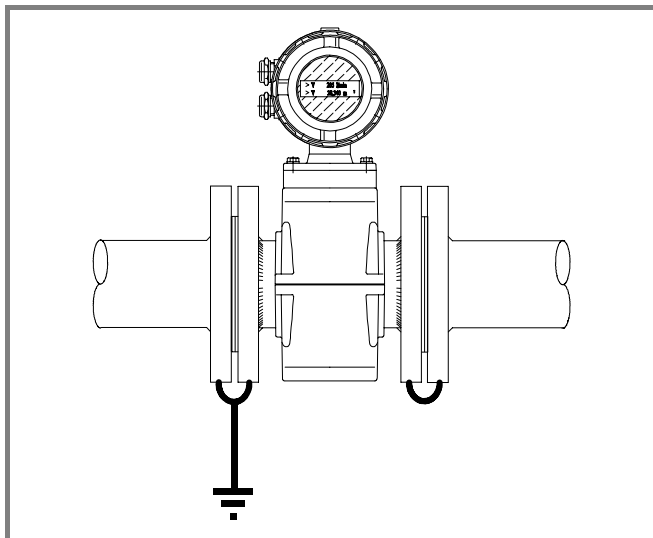

FIGURE 2-13.

#### 2.3.1.2 Grounding Type b) Pipeline

Weld stud (M6 or 1/4" dia.) upstream and downstream next to the grounding wire or grounding terminal of primary to the piping system.

With nuts, spring and flat washers and an additional 10AWG grounding wire, connect primary with pipeline and protective ground potential as shown in FIGURE 2-14.

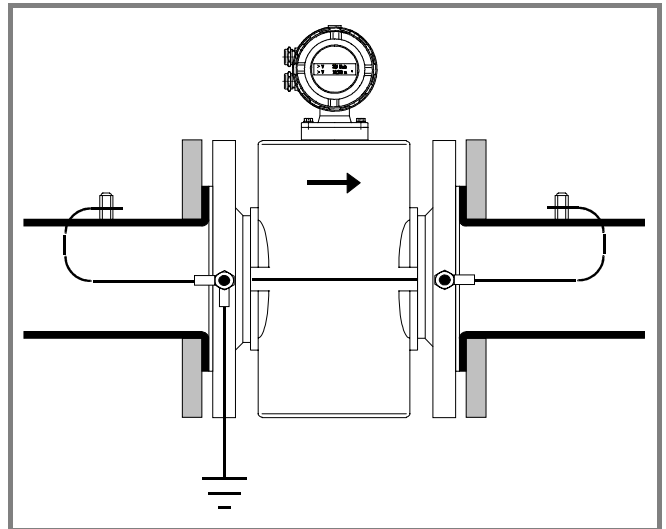

FIGURE 2-14

#### 2.3.1.3 Grounding Type c) Pipeline

Install grounding ring and primary in pipeline system. Place grounding ring upstream of primary with the lug protruding next to the grounding wire or grounding terminal of the primary.

With screws, nuts, washers and an additional 10AWG grounding wire, connect primary with grounding ring and protective grounding potential as shown in FIGURE 2-15.

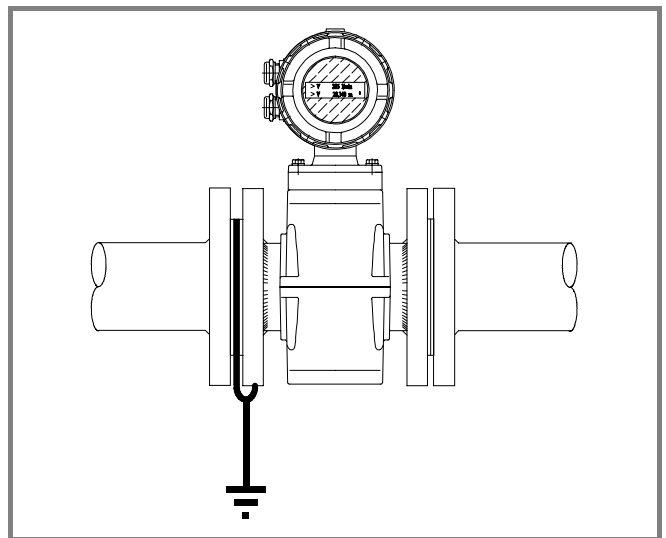

FIGURE 2-15.

### 2.3.2 Connection to Power Supply

**NOTE**

In accordance with the National Electrical Code (NEC) and to preserve the NEMA-4X rating, all electrical wiring to the Converter should be run in 1/2 in. NPT conduit. Conduit is **required** when equipment is used in hazardous locations.

Make certain the power supply voltage is the correct value according to information on the nameplate of the primary. Power supply connection terminals are identified differently depending on the specific model number of the meter. Connect power supply (depending on model) to terminals:

- L and N
- L+ and L-
- 1L1 and 1L2

Refer to terminal connection diagram FIGURE 2-19. When making power connections from the AC line, always use a fuse or circuit breaker as well as an ON/OFF switch. The fuse or circuit breaker rating must be within the capacity of the AC wiring used. The maximum power consumption of flowmeter including signal converter is <10 VA. Refer to grounding information presented in Section 2.3.1.

### 2.3.3 Connection of Input and Output Signals

The terminals for the input and output signals are located under the terminal housing cover opposite the electronics housing containing the digital display as shown in FIGURE 2-16. The electronic housing does not have to be opened in order to connect the leads. The 4-20mA current output is connected to the "+" & "-" terminals.

**NOTE**

In accordance with the National Electrical Code (NEC) and to preserve the NEMA-4X rating, all electrical wiring to the Converter should be run in 1/2 in. NPT conduit. Conduit is **required** when equipment is used in hazardous locations.

Terminals P7/G2 are available for contact output while terminals X1/G2 are available for contact input. Refer to terminal diagram Figure 2-19 and wiring diagrams Figures 2-21 & 2-22 for interconnection wiring.

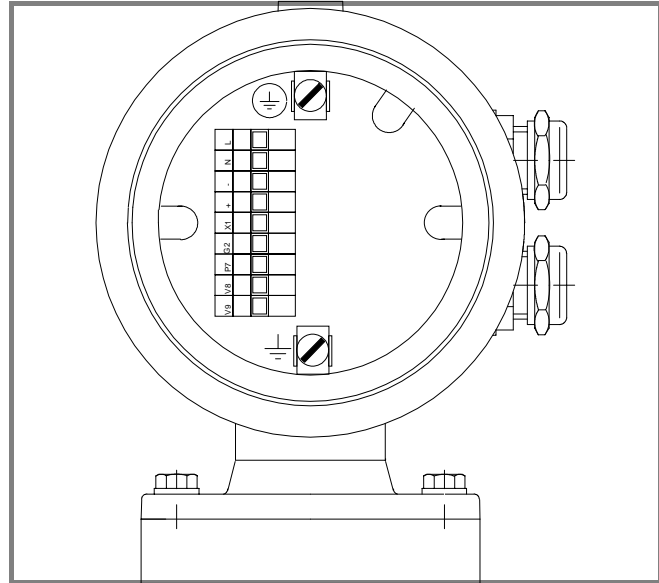

**FIGURE 2-16. TERMINAL HOUSING**

**NOTE**

When installing the power cable, it is recommended that any connections to the Primary be installed with a water trap as shown in FIGURE 2-17.

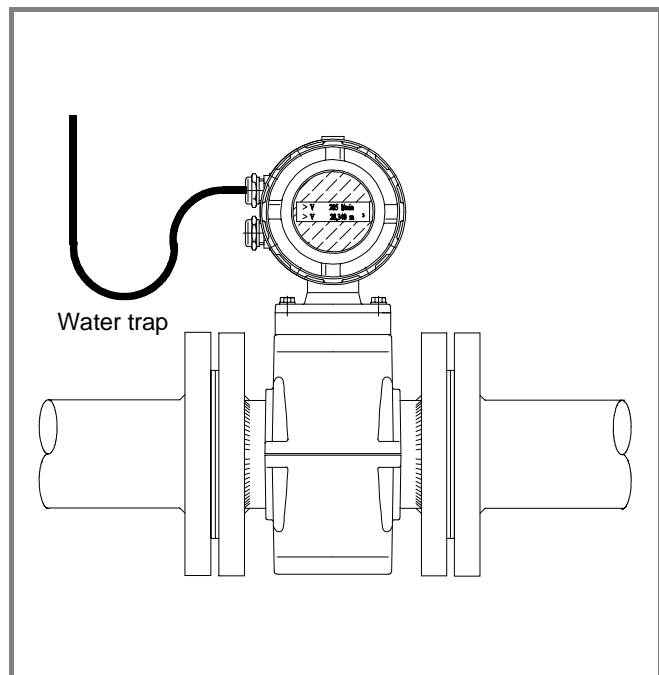
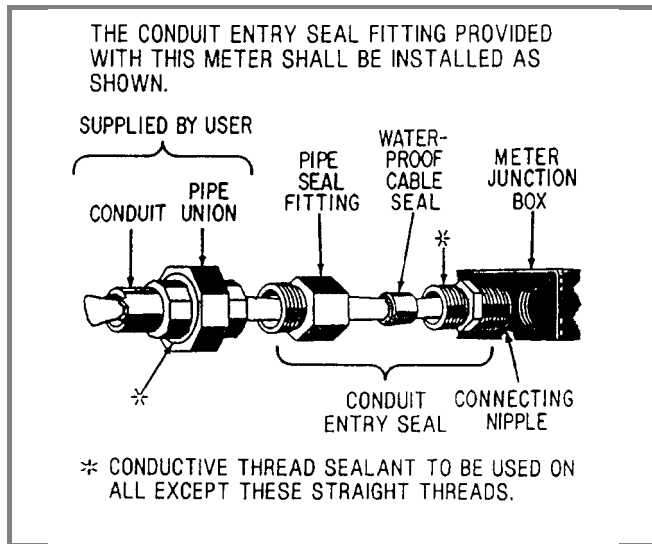

**FIGURE 2-15. CABLE ENTRY WITH WATER TRAP**



### 2.3.4 Conduit Entry Seal

The **conduit entry seal** will prevent the process liquid from entering the electrical conduit system. This seal consists of a conduit entry cable seal on the meter junction box. It is the user's responsibility to properly install the conduit entry cable seal fitting supplied with the Signal Converter interconnection cable. This will insure proper performance of this safety feature. Refer to Figure 2-18.



**FIGURE 2-18. CONDUIT ENTRY SEAL INSTALLATION**

### 2.3.5 Terminal Connection Diagram

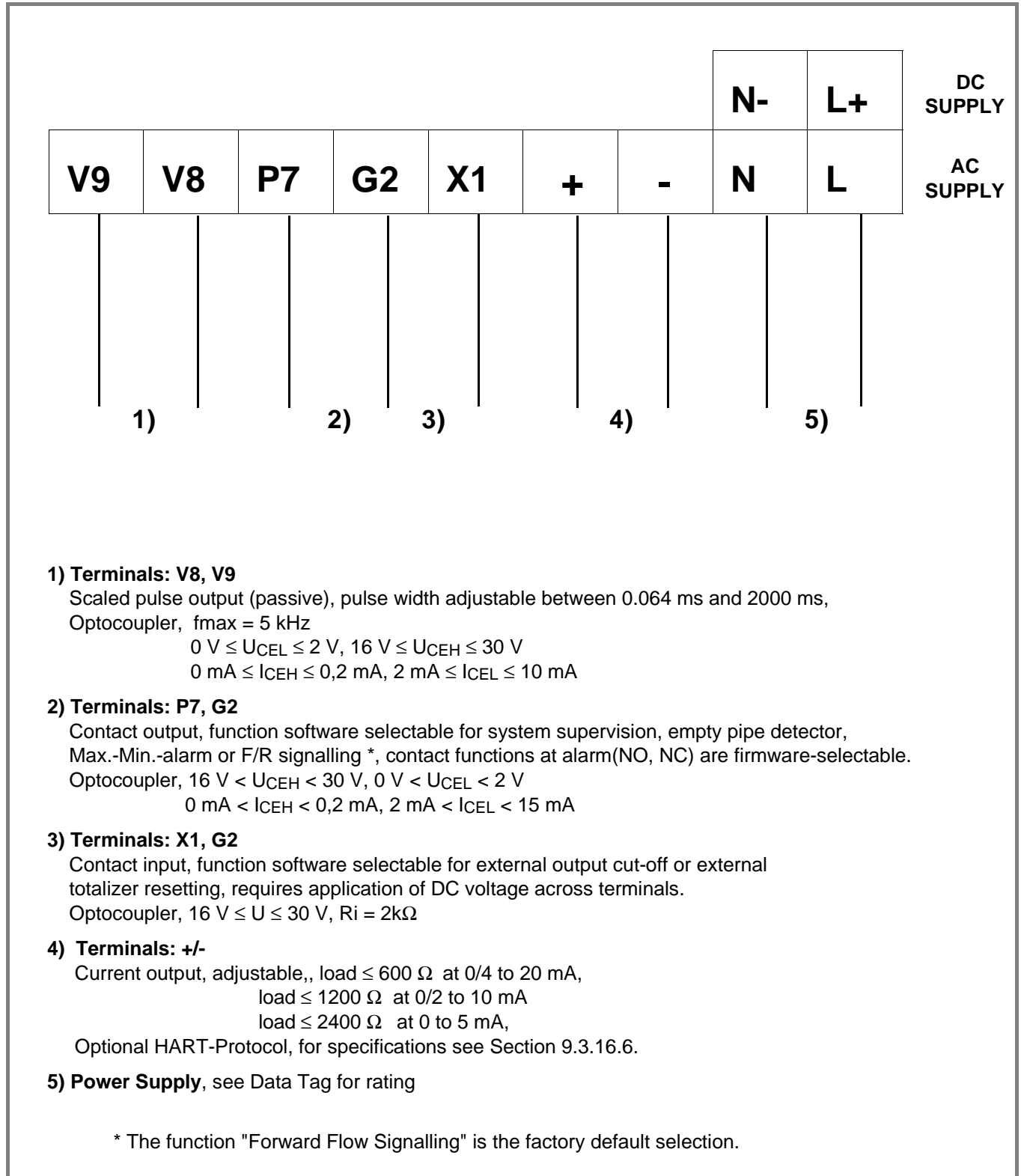

**FIGURE 2-19. TERMINAL CONNECTION DIAGRAM**

### 2.3.6 Connection Examples For Peripherals

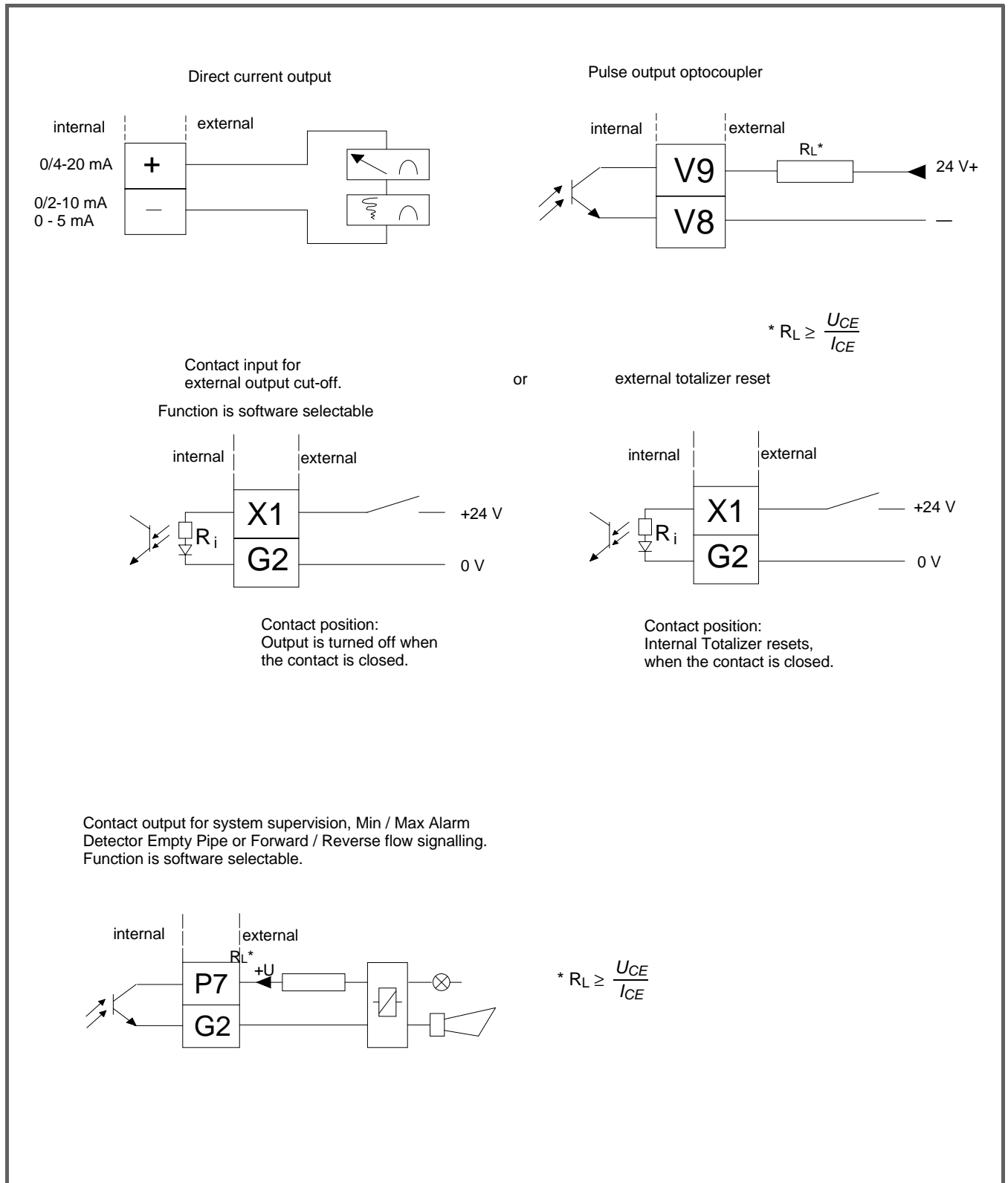
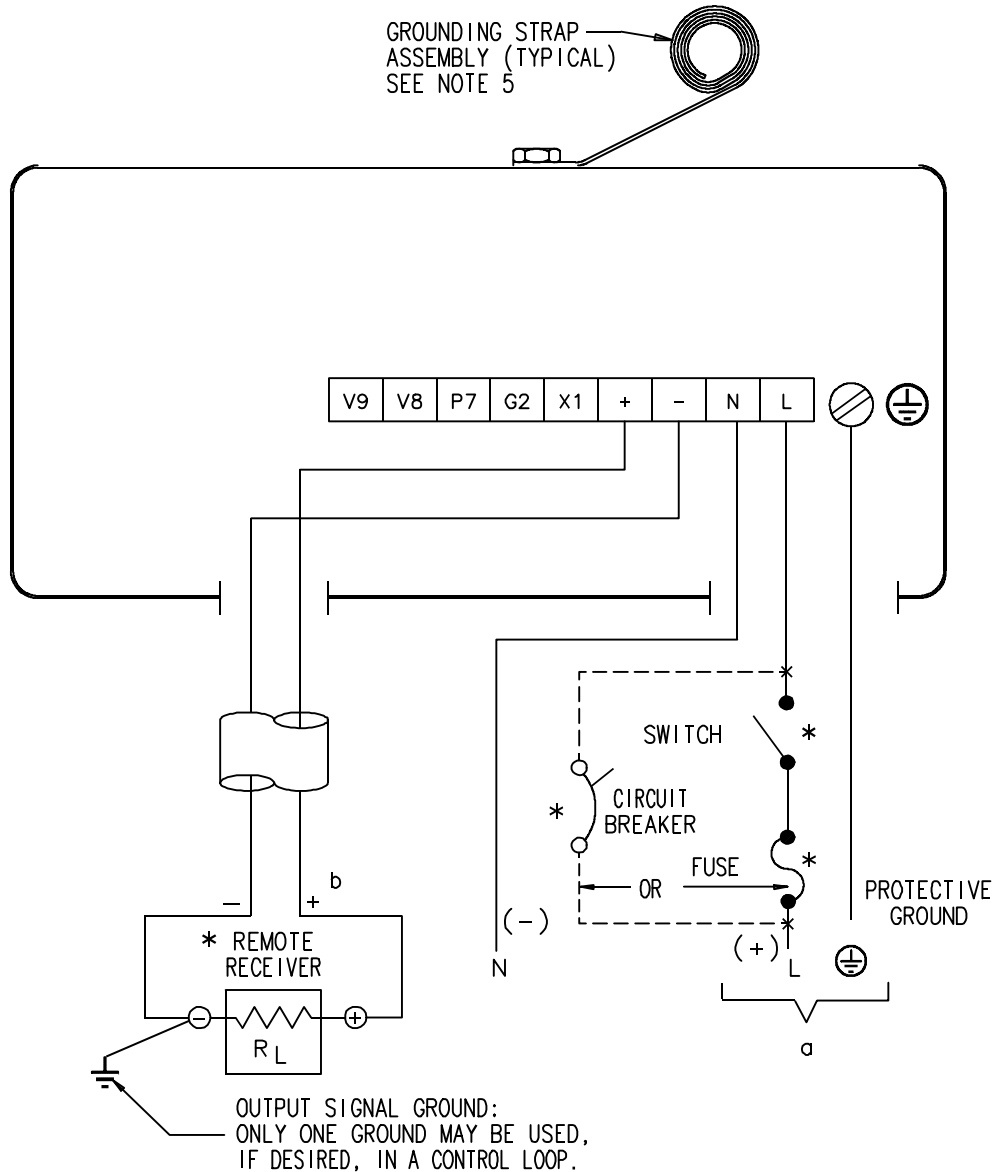

FIGURE 2-20. CONNECTION EXAMPLES FOR PERIPHERALS



1. \* INDICATES INTERFACE SUPPLIED BY CUSTOMER.
2. ALL WIRING FOR AMSI FLANGED METERS TO BE ENCLOSED IN METAL CONDUIT SUPPLIED BY CUSTOMER.
3. UNUSED CONNECTIONS MUST BE PLUGGED.
4. ALL CONDUIT CONNECTIONS ARE 1/2" NPT FOR ANSI & CABLE SEAL FOR DIN FLANGED METERS.
5. METER GROUNDING STRAPS ARE USED TO PREVENT STRAY ELECTRICAL CURRENTS FROM PASSING THROUGH THE METERED LIQUID. SEE INSTRUCTION BULLETIN FOR DETAILS.

### TERMINAL ASSIGNMENT TABLE

- a) POWER SUPPLY: 115/120 Vac, 50/60 Hz, 1 $\phi$ ; OR 24 Vdc  
(AS SPECIFIED ON DATA TAG)
- b) OUTPUT SIGNAL = 4-20 mA  
CURRENT OUTPUT R = <600 OHMS

50-1860r0

**FIGURE 2-21. STANDARD INTERCONNECTION WIRING DIAGRAM**

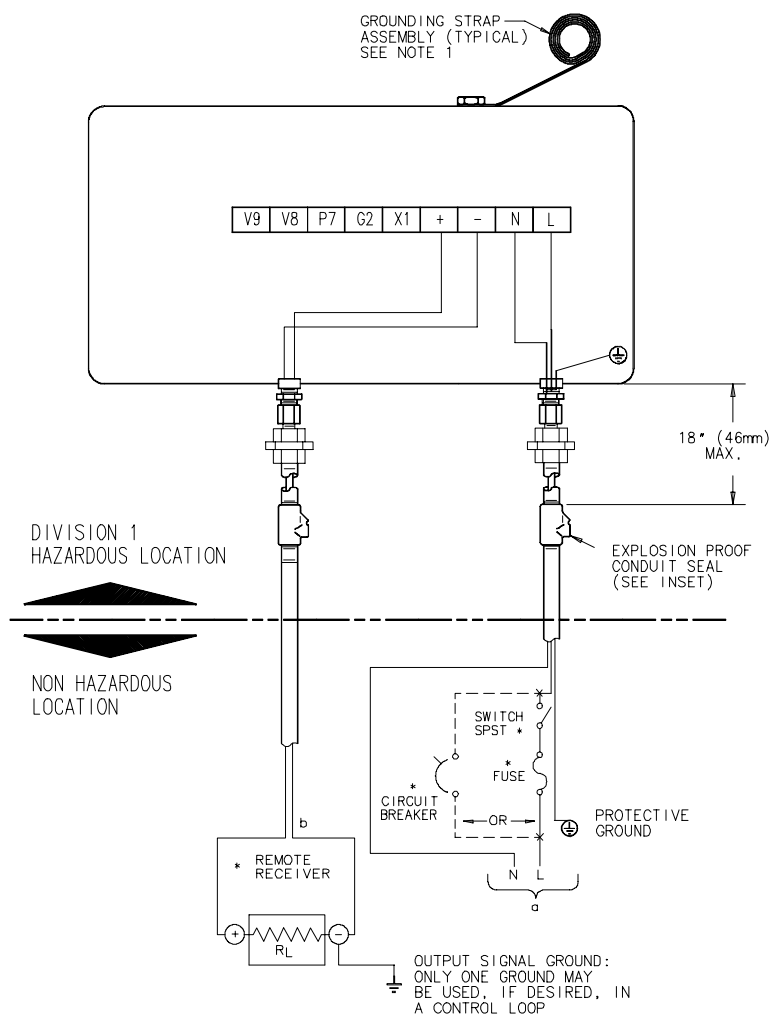

NOTES:

- \* INDICATES SUPPLIED BY CUSTOMER.
- 1. METER GROUNDING STRAPS ARE USED TO PREVENT STRAY ELECTRICAL CURRENTS FROM PASSING THRU THE METERED LIQUID. SEE INSTRUCTION BULLETIN FOR DETAILS.
- 2. UNUSED CONNECTIONS MUST BE PLUGGED TO MAINTAIN NEMA 4X RATING.
- 3. REMOTE RECEIVER LOAD AS FOLLOWS:  
RL = 0-750 OHMS
- 4. ALL MAGNETIC FLOWMETER SYSTEM WIRING TO BE ENCLOSED IN METAL CONDUIT.
- 5. TERMINAL ASSIGNMENT
  - a) POWER SUPPLY: 115/120 Vac, 50/60 Hz, 1 $\phi$ ; OR 24 Vdc (AS SPECIFIED ON DATA TAG)
  - b) OUTPUT SIGNAL = 4-20 mA  
CURRENT OUTPUT R = <600 OHMS

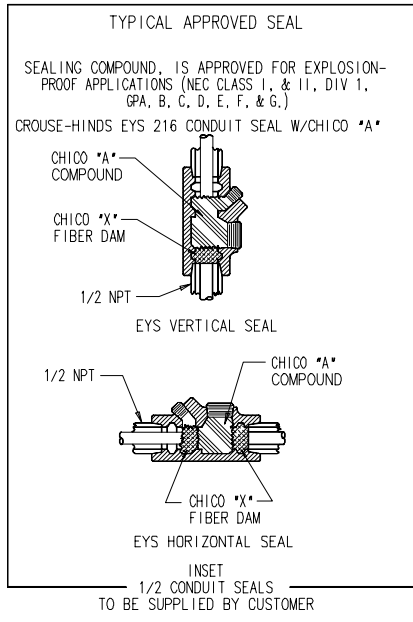

INSTALLATION REQUIREMENTS

NON HAZARDOUS LOCATIONS: WIRING SHALL COMPLY W/NATIONAL ELECTRICAL CODE & LOCAL ELECTRICAL CODE REQUIREMENTS

HAZARDOUS LOCATION: WIRING TO BE IN CONDUIT, BOXES, FITTINGS & SEALS TO COMPLY WITH ARTICLES 501, 502 OR 503, AS APPLICABLE, OF ANSI/NFPA 70 AND LOCAL ELECTRICAL CODE REQUIREMENTS

EQUIPMENT NOT SUPPLIED BY F & P (\*) TO BE LOCATED IN A NON-HAZARDOUS AREA UNLESS APPROVED FOR DIV. 1

50-1874r0

FIGURE 2-22. HAZARDOUS AREA WIRING DIAGRAM

## 3.0 MAINTENANCE

### 3.1 Maintenance of Primary

The 10DX4311 Primary is primarily a maintenance-free device and requires very little routine service. Once a year, the following items should be checked:

- Ambient conditions (ventilation, moisture)
- Sealing of flange connections
- Screw-type conduit fittings
- Cover screws
- Function of Power Supply
- Lightning Protection System
- Grounding connections

Electrode contamination of either an insulating or conductive nature may lead to different flow rate indication than expected and, consequently, the fluid flow will not be measured properly.

The primary electrodes will require cleaning if the flow rate indication on the converter's display varies while measuring a known constant volumetric flow.

#### WARNING

**All Flowmeters and/or Signal Converters being returned to ABB Instrumentation for repair must be free of any hazardous materials (acids, alkalis, solvents, etc). A Material Safety Data Sheet (MSDS) for all process liquids must accompany returned equipment. Contact ABB Instrumentation for authorization prior to returning equipment.**

### 3.2 Maintenance of Converter

#### 3.2.1 General

Except for an occasional performance verification check, there is no required routine maintenance for the Model 10DX4311. The Flowmeter body is of all welded construction. In the event a malfunction occurs in the primary, the meter body must be replaced. If supplied, the integrally mounted Signal Converter assembly is removable for maintenance or replacement purposes.

ABB Instrumentation offers a Repair/Exchange Program to facilitate replacement of a defective meter or converter. If the equipment is beyond the warranty limit, a fixed price will be charged under this program for replacement of defective equipment with appropriate credit issued when the repairable unit is received by ABB Instrumentation (charges prepaid).

The equipment available under this program is as follows:

- the complete Flowmeter with integrally mounted Signal Converter and installation hardware
- the Flowmeter, without the Signal Converter
- the Signal Converter assembly

#### CAUTION

**Some of the IC devices used in the signal converter are static sensitive and may be damaged by improper handling. When adjusting or servicing the signal converter, use of a grounded wrist strap is recommended to prevent inadvertent damage to the integral solid state circuitry.**

The signal converter uses complex electronic circuit components. Generally, due to the complexity of troubleshooting integrated circuit devices, maintenance beyond the assembly level is not recommended. Also, caution must be used when connecting test probes, as even a momentary accidental short circuit may damage or destroy an integrated circuit device. Therefore, only trained electronic technicians who are familiar with CMOS technology and have a background in logic and gating circuitry should be permitted to service this equipment.

In the event of a malfunction in the Signal Converter assembly, a replacement electronics assembly can be easily substituted for the defective assembly, thereby minimizing system down-time (see Section 3.2.4). Servicing by substitution of spare assemblies is generally more economical than stocking a large variety of IC chips, transistors, diodes, etc. Also, test equipment requirements and the level of technical expertise necessary are minimized. Should any doubt arise regarding the proper procedure for solving an existing problem, it is suggested that the user contact his local ABB Instrumentation service facility for technical assistance.

#### WARNING

**ELECTRICAL SHOCK HAZARD. Equipment powered by an ac line voltage presents a potential electric shock hazard. Servicing of the Magnetic Flowmeter or Signal Converter should only be attempted by a qualified electronics technician.**

When communicating with ABB Instrumentation regarding the replacement of a complete meter (with

integrally mounted Converter), the meter body, or the Signal Converter, it is important to refer to the complete instrument serial number to assure that the correct replacement will be supplied. The subject information is provided on the manufacturing specification sheet supplied with the Magnetic Flowmeter as well as on the instrument data tags.

### 3.2.2 System Troubleshooting

In the event faulty operation of the Magnetic Flowmeter is evident, the following procedure can be used as a guide to isolate the malfunctioning device to either the Flowmeter or the Signal Converter. A standard multimeter and an oscilloscope are suitable for making the test measurements.

1. If meter operation is suspect, proceed as follows:

- a) Remove front & rear access covers from the Converter housing by turning them counter-clockwise until they separate from the housing.
- b) Inspect for evidence of water entry in the connection box and Converter electronics compartment.

If there is any evidence of water entry, de-energize system at power source. Inspect conduit seals and cover gaskets for possible source of water entry. Replace the seals and/or gaskets if evidence of water entry is indicated. Allow interior of Converter housing to dry completely before restoring system power.

2. Possible causes of erroneous flow rate indication are:

- incorrect grounding
- excessive noise due to a heavy slurry process or a non-homogeneous process
- loose or intermittent wiring
- partially empty or empty meter pipe
- excess air entrained in process liquid

### 3.2.3 Static Test

If improper operation of the Magnetic Flowmeter is suspected, the following resistance measurements can be made to establish whether an electrical malfunction has occurred. A standard multimeter is suitable for making the resistance checks. These measurements can be made at the coil connector located on the top circuit board assembly of the converter electronics assembly.

**Note:** The illustrations of the Converter electronics show an earlier model of the electronics. Later versions have an EEPROM module located above the LCD display in the area indicated in FIGURE 3-1. This EEPROM is shown pictorially in FIGURES 6-1 AND 9-3.



**FIGURE 3-1. NEW EEPROM MODULE**

#### 3.2.3.1 Magnet Coil Check

There are two magnet coils in the meter that are connected in a series arrangement. The coil leads are brought up to a 2-pin connector on the top printed circuit board assembly in the Converter housing. To gain access to this board assembly, remove the Converter's front cover (display cover) by turning the cover counter-clockwise until it disengages from the housing. The coil-connection header is located on the right edge (when facing the display) of the top board assembly (refer to FIGURE 3-2).

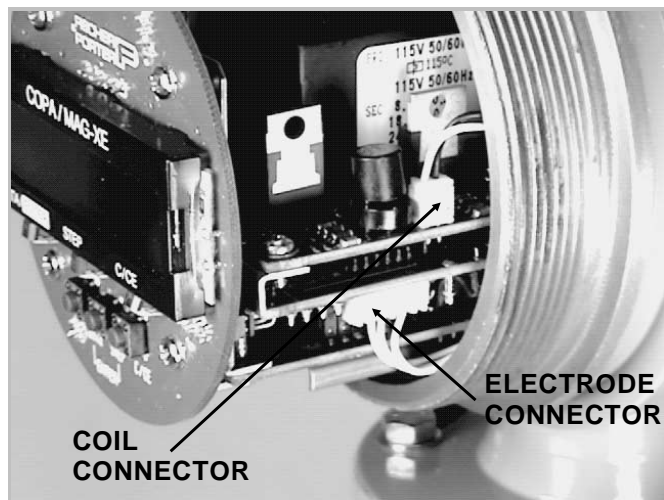

**FIGURE 3-2. INTERFACE CONNECTORS**

Before making resistance measurements, verify that the system power service has been de-energized. Remove the electronics housing cover to obtain access to the Primary board.

#### **WARNING**

Inside edges of the Converter housing casting may be very sharp! Use recommended tools, not fingers, to disconnect plugs from the connectors, otherwise injury may result!

- 1) Set the ohmmeter to its lowest range; e.g., R x 1.
- 2) Carefully disconnect the 2-terminal coil connector from the printed circuit board by using needle-nose pliers to grasp the sides of the plug and pulling the plug upward, away from the printed circuit board, and out of the receptacle.
- 3) Connect the ohmmeter test leads to the plug terminals inside the plug housing (not the header terminals on the board assembly). It may be necessary to insert small wires into the plug holes to insure reliable contact of the ohmmeter leads to the terminals. The value displayed should correspond to the value ( $\pm 20\%$ ) indicated in Table 3-1.

**TABLE 3-1. PRIMARY COIL RESISTANCE**

Meter Size		Total Coil Resistance
inch	mm	Ohms (nominal)
6	150	74
8	200	50
10	250	42
12	300	42

If proper coil resistance is measured, it can be assumed that the magnet coils are functional. If the reading is different from the values in Table 3-1, the Magnetic Flowmeter must be replaced.

- 4) Set the Ohmmeter to its highest range (R x 10,000) and measure from each coil-connection plug terminal to the converter body (case ground). The resistance reading should be infinite. If this measurement is less than 100K ohms, the meter is defective and must be replaced.

If all measurements appear normal, the coil connector may be reconnected (observe the proper plug orientation, the plug is mechanically "keyed" to the receptacle). After the coil connector is reconnected to the printed circuit board, replace the Converter housing cover and return the meter to service.

**3.2.3.2 Electrode Check**

The electrode check is essentially a resistance measurement that can be made to establish that a short (or high resistance leakage path) does not exist between one, or both, electrodes and the meter body.

Before proceeding, verify that system power has been de-energized. To perform this test, the meter must be removed from the pipeline and the meter liner "wiped" dry.

When the meter liner has been thoroughly dried, proceed as follows:

- 1) Remove cover from the Converter housing electronics compartment.
- 2) Place ohmmeter on highest available range (for example, R x 10,000).
- 3) Locate the 6-terminal electrode connector on the underside of the bottom printed circuit board assembly in the Converter electronics housing. FIGURE 3-2 shows the location of this connector. Carefully remove the connector from the printed circuit board by using needle-nose pliers to grasp the plug by its sides and pulling the plug out of the receptacle.
- 4) Connect the ohmmeter "minus" lead to an unpainted part of the Converter housing (ground) and the "plus" lead to plug connector pin 1. Plug pin numbers can be found marked on the circuit board next to the electrode connector receptacle as shown in FIGURE 3-3. The reading on the ohmmeter should be infinite. If any resistance is measured, the meter is defective and must be replaced.

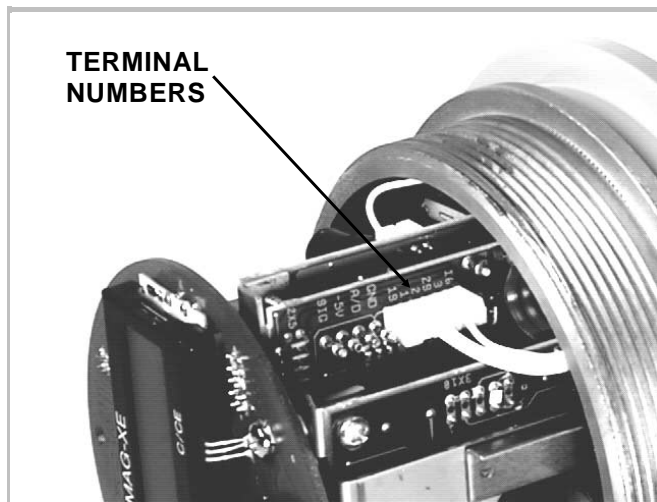

**FIGURE 3-3. ELECTRODE PIN NUMBERS**

- 5) Check the other electrode by connecting the ohmmeter "plus" lead to plug connector pin 2. This reading must also be infinite. If any resistance is measured, the meter is defective and must be replaced.



6) If measurement of both electrodes indicates an infinite resistance reading, the meter may then be returned to service. Reconnect the electrode connector (observe the proper plug orientation, the plug is mechanically aligned or "keyed" to the receptacle) and replace the Signal Converter cover. Return the meter to normal operation.

**CAUTION**

Use care when reconnecting the Converter coil and electrode interface connections to insure that the plugs are in proper alignment with the pins of the headers. If these connectors do not mate correctly, the Signal Converter will be inoperable and could be damaged when power is applied.

**3.2.4 Replacing Converter Electronics**

In the event it becomes necessary to replace the Converter electronics assembly or the power fuse, the following procedure may be used:

**WARNING**

Inside edges of the Converter housing casting may be very sharp! Use recommended tools, not fingers, to disconnect plugs from the connectors, otherwise injury may result!

- 1) Using needle-nose pliers, remove the coil and electrode connectors from the electronics assembly (see FIGURE 3-2).
- 2) Remove the I/O connector, shown in FIGURE 3-4, using needle-nose pliers.



**FIGURE 3-4. I/O CONNECTOR LOCATION**

3) Remove the two electronics assembly mounting screws to disconnect the electronics assembly from the converter housing (refer to FIGURE 3-5).

To protect against loss of the screws, the screws are "captured" and will remain in the mounting ears.

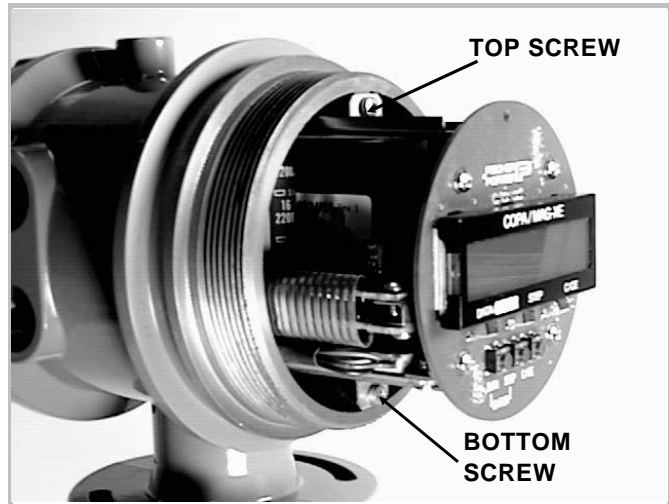

**FIGURE 3-5. MOUNTING SCREWS**

4) Carefully pull the electronics assembly forward until the power connector (shown in FIGURE 3-6) is visible.

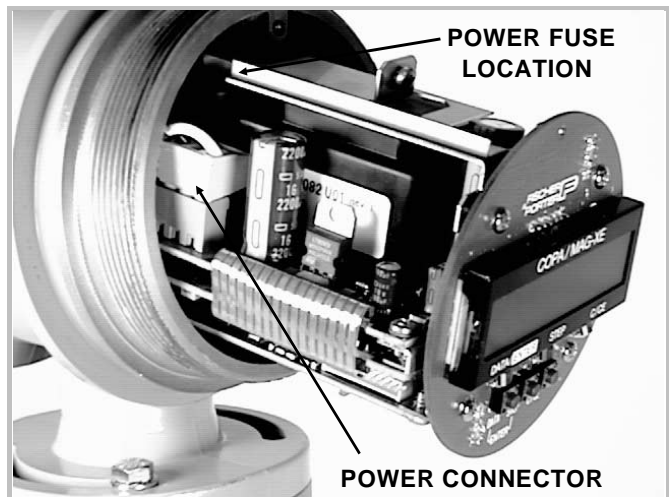

**FIGURE 3-6. POWER CONNECTION**

5) Hold the electronics assembly and use needle-nose pliers to carefully pull the power connector out of its housing.

6) Remove the electronics assembly from the Converter housing and replace the fuse (location shown in Figure 3-6).

7) If replacing the electronics assembly, remove the EEPROM module (See Figure 3-1) and reinstall it on the replacement electronics assembly. Go to "Load data from external EEPROM" menu and upload programmed data.

8) To reinstall the electronics assembly, reverse the above procedure.

## 4.0 PARTS

### 4.1 Gaskets

Some models of the flowmeter are supplied with gaskets. Potential leakage can only be avoided by using and correctly installing the gaskets supplied by ABB Instrumentation. For flowmeter models not supplied with gaskets, use commercially available gaskets that are appropriate for the application and are made of material consistent with the type of fluid and the process temperature (rubber, PTFE, etc.).

Two gaskets are required for each meter. If the meter has grounding rings, two additional gaskets are required for each meter.

When installing the gaskets, follow the procedures provided in Section 2.0.

**NOTE**

If it becomes necessary to repair the lining, the electrodes or the coils, it is recommended that the meter be returned to the factory that originally supplied the meter. Before returning the meter for repair, observe the "**WARNING**" instructions in Section 3.0.

**NOTE**

Polyurethane, neoprene & hard-rubber lined meters use neoprene gaskets. TEFLON & TEFZEL lined meters use TEFLON gaskets.

**TABLE 4-1. FLANGE GASKETS FOR METER BODY**

Meter Size		Flange Class	Liner Material		
Inches	mm		TEFLON / TEFZEL	Polyurethane	Neoprene / Hard Rubber
6	150	ANSI 150	333N811P30	333N811Q10	333C371Q10
		ANSI 300	333N801P30	333N801Q10	333C378Q10
8	200	ANSI 150	333N812P30	333N812Q10	333C372Q10
		ANSI 300	333N802P30	333N802Q10	333C379Q10
10	250	ANSI 150	333N807P30	333N807Q10	333C382Q10
		ANSI 300	333N821P30	333N821Q10	333C514Q10
12	300	ANSI 150	333N806Q10	333N806Q10	333C383Q10
		ANSI 300	333N803P30	333N803Q10	333C513Q10

### 4.2 Wiring Entry Seal Parts Kit

ANSI Flanges (Conduit Seal) - **P/N 699B390U02** (Provides seals for both entry ports)

DIN Flanges (Cable Seal) - **P/N D150A004U01** (Provides seals for one entry port only - 2 kits required)  
**P/N 1D150Z1053** (Dust Cover - 2 required)

### 4.3 Grounding Rings

Order number consists of one grounding ring and mounting screws. Order a quantity of two for each meter. Order by the referenced part number.

**TABLE 4-2. GROUNDING RINGS - SIZES 6 THROUGH 12 INCHES**

Meter size		Flange Rating ANSI Class 150	Flange Rating ANSI Class 300
		304 sst with <u>neoprene gasket</u>	304 sst with <u>neoprene gasket</u>
Inches	mm	Part Number	Part Number
6	150	644B009U01	644B009U23
8	200	644B009U03	644B009U25
10	250	644B009U69	644B009U71
12	300	644B009U70	644B009U72

Meter size		Flange Rating ANSI Class 150	Flange Rating ANSI Class 300
		304 sst with <u>TEFLON gasket</u>	304 sst with <u>TEFLON gasket</u>
Inches	mm	Part Number	Part Number
6	150	644B009U02	644B009U24
8	200	644B009U04	644B009U26
10	250	644B021U19	644B021U21
12	300	644B021U20	644B021U22

## 4.4 Protector Plates

**TABLE 4-3. PROTECTOR PLATES FOR TEFLON & TEFZEL LINED METERS - SIZES 6 THROUGH 12 INCHES**

Order number consists of two protector plates and mounting screws. **Grounding rings are not available for this application.** When ordering, specify **614B384U\_\_** and suffix from the table below.

Protector Plate Material	Meter Size Inches = (mm) =	Flange Rating ANSI Class 150				Flange Rating ANSI Class 300			
		6 (150)	8 (200)	10 (250)	12 (300)	6 (150)	8 (200)	10 (250)	12 (300)
316 sst	Suffix =	01	07	13	19	04	10	16	22
HAST "C"	Suffix =	02	08	14	20	05	11	17	23

## 4.5 Hardware

Screw, Base to Meter Body - **P/N 22J112AU20** (Qty. 2)  
 Washer, Base to Meter Body - **P/N 85A027CU20** (Qty. 2)  
 Cover O-Ring - **P/N 101A820U01** (Qty. 2)

## 4.6 Fuses

### 4.6.1 Power

115/120 VAC Model, 1/4 Amp 5 x 20mm Slo-Blo - **P/N D151B001U03**  
 230/240 VAC Model, 1/8 Amp 5 x 20mm Slo-Blo - **P/N D151B001U08**  
 24VDC Model, 1/2 Amp 5 x 20mm Slo-Blo - **P/N D151B025U05**

Refer to Section 3.2.4 and Figure 3-6 for fuse access and location.

### 4.6.2 Coil-Circuit Fuse

Type TR5, Slow-Blow, 160 mA **P/N 151B058U03**

## 4.7 Magnetic Programming Stick

Magnetic Stick - **P/N D614K001U01**

## 5.0 START UP

### 5.1 Preliminary Check List

Follow these start up instructions after completing the assembly and installation of the primary and converter:

- Check that the flow direction of the fluid agrees with the flow-direction arrow on the primary housing.
- Check that the flowmeter is properly grounded. See Section 2.3.1.
- Check that the interconnections agree with the interconnection diagram in Section 2.3.5.
- Check that the power supply agrees with the specifications on the nameplate.
- Check that the ambient conditions meet the conditions listed in Section 9 - Technical Data.

**WARNING**  
**Electrical Shock Hazard. Equipment powered by an AC line voltage presents a potential electric shock hazard. Servicing of the Magnetic Flowmeter or Signal Converter should only be attempted by a qualified electronics technician.**

### 5.2 Turn Power On

The display should become active and show information similar to that shown on page 6-1.

- Some parameters must be entered for proper system operation:
  - Enter the meter size stamped on the nameplate in the "Size" parameter.
  - The range is automatically set to 10 m/s. Enter the desired maximum forward and reverse flow values in the appropriate units.
  - Hydraulically ideal range end values are approximately 5-10 ft/sec (or 2-3 m/s).
  - Select the desired output current range in the "Submenu Current Output".
  - Set the number of pulses per unit, the pulse width and the Totalizer Submenu for the Passive Pulse Output.
- Check the system zero (Refer to Zero Check, Section 5.3).

### 5.3 Zero Check

The system zero must be set at the Converter. For this parameter, all flow activity through the flowmeter must be totally stopped. Make certain that the meter pipe of the primary is totally full of fluid. The zero can be set either manually or automatically at the Converter by accessing the parameter "System Zero". Select the menu parameter with the ENTER key and use the arrow keys to select either automatic or manual. Accept the selected parameter by pressing the ENTER key. During the automatic zero adjustment the 2nd line of the display on the converter counts from 255 to the actual zero value, after which the system zero adjustment cycle is ended. The automatic adjustment cycle takes approximately 20 seconds to complete. Refer to page 6-5.

### 5.4 Detector Empty Pipe (option)

The empty pipe module, when installed, should be adjusted at start up under actual conditions. Refer to Instructions on page 6-7.

### 5.5 EEPROM

All parameter values are stored in the main EEPROM located on the display board assembly. If replacing the electronics, remove the EEPROM from the original electronics and insert it into the replacement electronics. On power-up, all data should be accepted and need not be entered again. To insure this, perform a data "upload" using the "Load data from external EEPROM" menu (refer to Section 6.4).

**NOTE**  
 After all parameters have been set and entered they should be saved in the external EEPROM, refer to the "Store data in external EEPROM" menu command in Section 6.4 for more details.

If any menu parameter is ever changed from a previous value, it is always good practice to "download" the new data using the "store data in external EEPROM" menu to insure that the new data is retained in the event of a power loss.

## 6.0 OPERATION: DATA ENTRY & CONFIGURATION

### 6.1 Display Indications

Initially, after the power is first turned on, the converter model number is shown in the first line of the display and the revision level in the second line. Subsequently the actual process information is displayed.

The instantaneous flow rate direction (→F for forward flow or ←R for reverse flow) is displayed on the first line together with the flow value in percent or in direct reading units. The totalizer value for the existing flow direction, up to 7 digits, is displayed in the second line with its corresponding units.

The totalizer values displayed are always those actually measured in their appropriate units, regardless of the pulse factor selected. This display is designated as process information throughout the remainder of this manual.

The totalizer value in the other flow direction can be displayed by pressing the STEP or DATA pushbuttons.

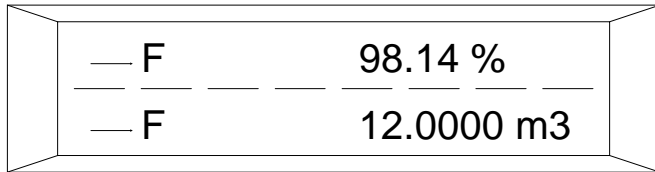

1st line Instantaneous forward flow rate

2nd line Reverse flow totalizer value

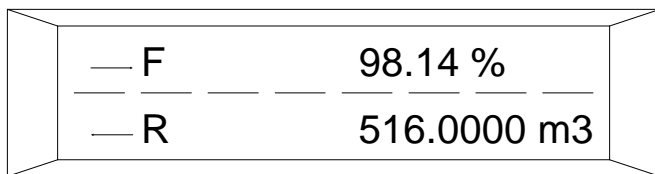

1st line Instantaneous forward flow rate

2nd line Reverse flow totalizer value (Multiplex operation)

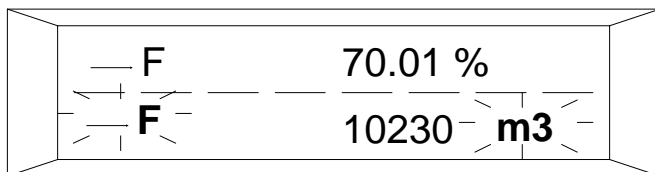

1st line Instantaneous forward flow rate

2nd line Totalizer overflow. > F and m<sup>3</sup> are blinking.

A totalizer overflow occurs whenever the totalizer value exceeds 9,999,999. When a value in either of the flow directions exceeds 9,999,999, the flow direction symbol (→F or ←R) and the units displayed in the 2nd line (e.g. m<sup>3</sup>) blink. The software can store up to 250 totalizer overflows. The overflow indication can be turned off by pressing ENTER independently for each flow direction (refer to section 6.17, page 6-11).

An error message will appear in the 1st line when an error condition is detected.

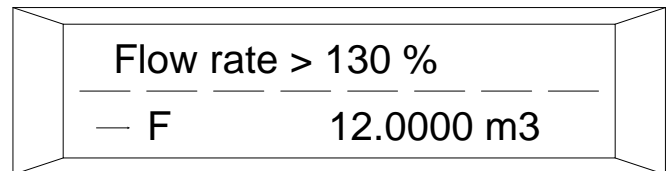

Display of the error message will alternate with the corresponding error code on the top line of the display. Only the error message with the highest priority is displayed in text, but codes of all encountered error conditions are displayed according to the table below).

**TABLE 6-1. ERRORS vs. PRIORITY**

Error code	Clear text / Cause
0	Empty pipe Pipe not completely full
1	A/D over load A/D-converter saturated
2	REF too low Pos. or neg. excitation too low
3	Flow rate 130 % Flow rate >130 %
4	External zero return Ext. zero return contact actuated
5	EEPROM defect Data in EEPROM corrupted
6	Totalizer Totalizer value corrupted
7	REFp too high Positive excitation too high
8	REFn too high Negative excitation too high

Additionally during an error condition an output from the alarm relay or optocoupler is generated and the current and frequency outputs are driven to 0 or 130% (except for Error 6).

## 6.2 Data Entry

Data is entered either by pressing the STEP $\uparrow$ , DATA $\downarrow$  and C/CE pushbuttons or by using a magnetic "programming stick" to activate magnetic sensors.

The cover must be removed from the housing to gain access to the STEP $\uparrow$ , DATA $\downarrow$  and C/CE pushbuttons on the converter but need not be removed when programming using the "magnetic stick".

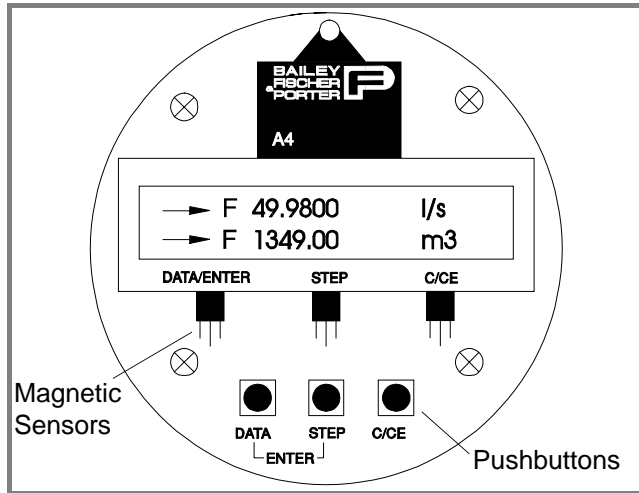



**FIGURE 6-1. PUSHBUTTONS & CONVERTER DISPLAY**



### CAUTION

The "magnetic programming stick" is a very strong magnet. Avoid getting the magnet near any magnetic media (such as floppy disks) since inadvertant data loss may result.

The converter remains active during data entry, i. e. the current and pulse outputs are a function of the actual instantaneous flow values. The functions of the pushbuttons are described below:

-  C/CE The C/CE pushbutton is used to toggle between the process mode and the menu.
-  STEP  $\uparrow$  The STEP pushbutton is one of two arrow buttons. **Pressing STEP pages through the menu in the forward direction.**
-  DATA  $\downarrow$  The DATA pushbutton is the other arrow button. **Pressing DATA pages through the menu in a reverse direction.**
- ENTER **Manual mode:** the ENTER function requires that both STEP and DATA pushbuttons be pressed simultaneously. The Program Protection can be turned on and off by pressing ENTER.

**Magnetic mode:** When using the optional "magnetic stick" for operation, the ENTER function is performed by holding the magnetic stick over the DATA/ENTER sensor for longer than 3 seconds. Acknowledgement is indicated by the display flashing.

-  STEP  $\uparrow$  Additionally, ENTER is used to gain access to the parameter to be changed and to store the new data selected or set in the parameter.
-  DATA  $\downarrow$  The ENTER function is only in effect for 10 seconds. If no entry is made during this 10 second period, ENTER must be pressed again.

There are two methods of data entry:

- Direct number entry
- Input from a table menu.

The previous value will be displayed on the converter after 20 seconds if no data is entered. After an additional 10 second period delay, the display reverts to indicating the process information.

### NOTE

During data entry the input values are checked for acceptability. If data is not acceptable, it is rejected and a message is generated indicating that the new data has not been accepted.

### 6.3 Instructions For Entering Data Into the Converter

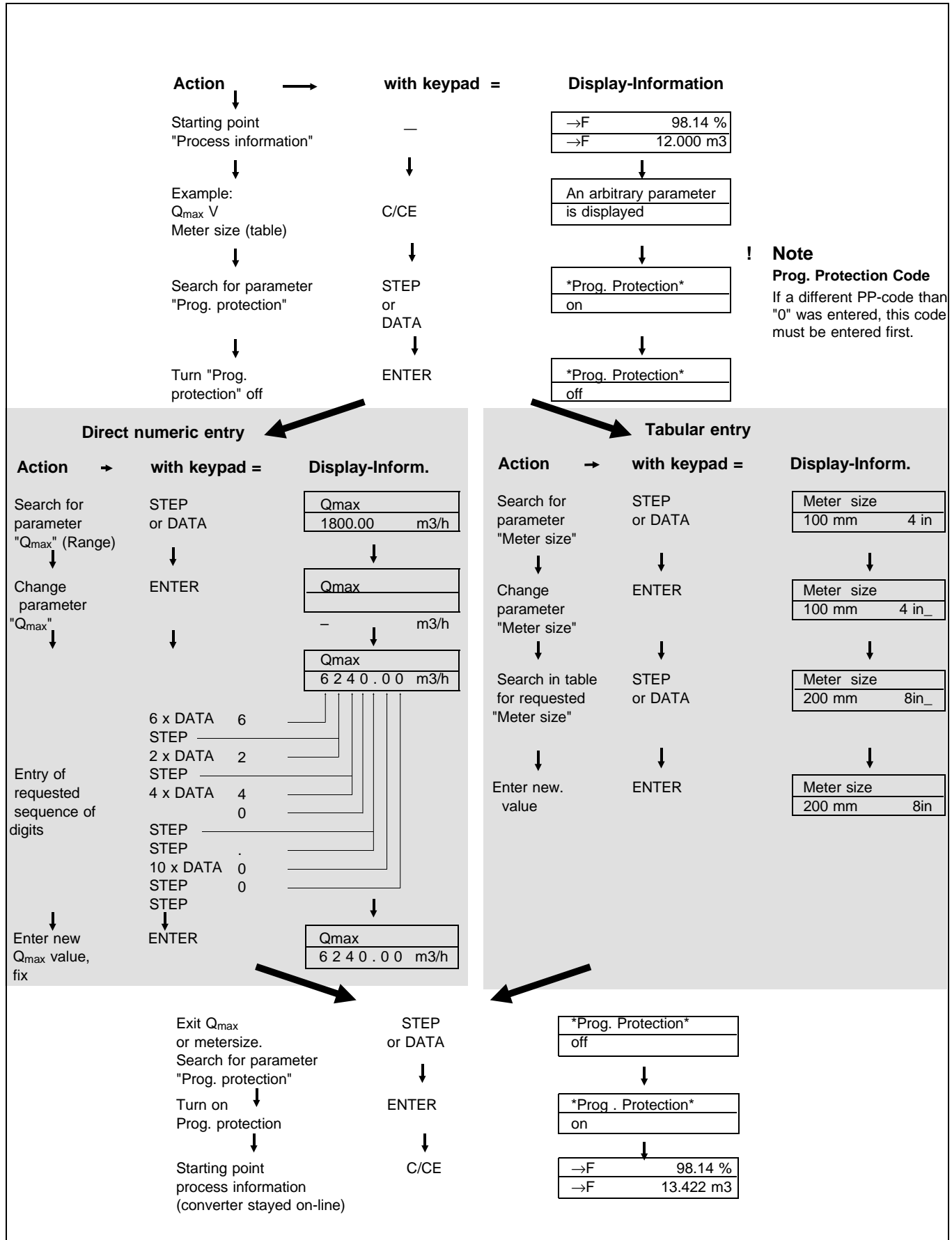



### 6.4 Menu Sequence

The listing below gives a general overview of the standard top-level display menu sequence when running firmware version A.28

The listing in Section 6.5 shows the standard display menu sequence and submenus using the **↑Step** button to move through the menu items. The first message displayed the first time the **C/CE** button is pressed after the converter is powered up is "**Prog. Protection ON**". Thereafter, pressing the **C/CE** button while the converter is in monitoring mode will display the parameter that was last exited. Program Protection may be turned "**off**" by pressing the **ENTER** function when the Prog. Protection menu is displayed. When the last menu item is reached, the firmware "wraps around" and scrolls to the first item on the menu once again.

The menu items in the first column are upper-level configuration mode functions. Submenu selections (shown indented in the second column) only appear if the associated upper level is selected by pressing the **ENTER** function. The allowable selections of sub-menu items which are selected by tabular means are shown in detail in Section 6.0

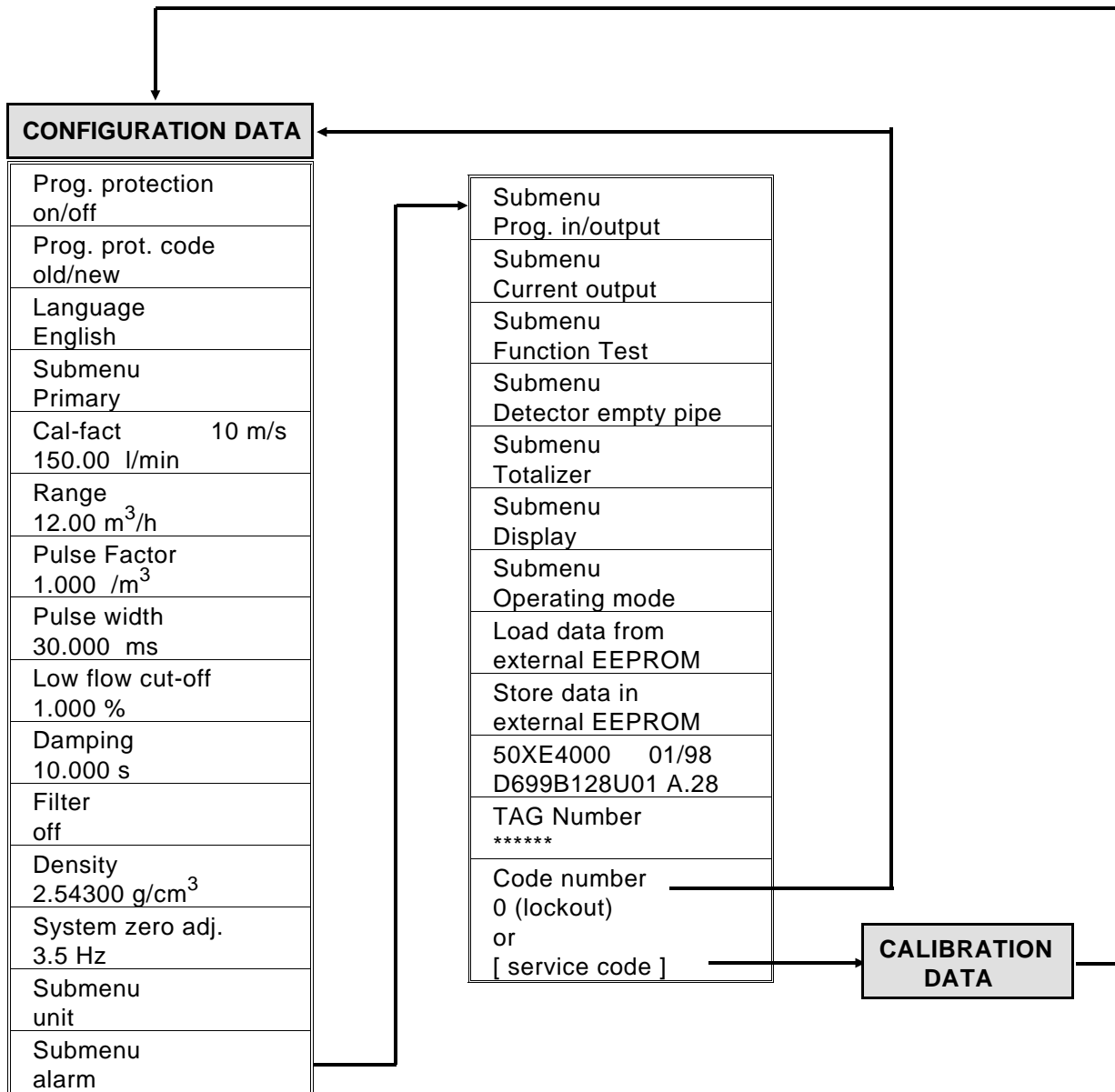

### 6.5 Parameter Summary and Data Entry

Submenu / Parameter	Entry mode	Description
<div style="border: 1px solid black; padding: 2px; width: fit-content;">Prog. Protection off</div>	tabular/numeric	Data entry is only possible by turning "Prog. Protection" off. When initially powered-up, "Prog. Protection" is "ON".
ENTER	<div style="border: 1px solid black; padding: 2px; width: fit-content;">Prog. Protection off</div>	on / off
	<div style="border: 1px solid black; padding: 2px; width: fit-content;">PP-code ? 0</div>	If a different program protection code (1-255) than "0" was entered (factory entry), this code must be entered first in order to turn off the program protection.
	<div style="border: 1px solid black; padding: 2px; width: fit-content;">Prog. Protection off</div>	Once Program Protection has been turned off, parameters may be changed.
<div style="border: 1px solid black; padding: 2px; width: fit-content;">Prog. Protection code</div>	numeric	After the Program Protection has been turned off the Program Protection code can be changed.
ENTER	<div style="border: 1px solid black; padding: 2px; width: fit-content;">Old PP-code ? 0</div>	Enter old Program Protection code. 0 = factory entry
	<div style="border: 1px solid black; padding: 2px; width: fit-content;">New PP-code: 0</div>	Enter new program protection code (0-255).
<div style="border: 1px solid black; padding: 2px; width: fit-content;">Language English</div>	tabular	German, English, French, Finnish, Spanish, Italian, Dutch, Danish, Swedish.
<div style="border: 1px solid black; padding: 2px; width: fit-content;">Submenu Primary</div>		
ENTER	<div style="border: 1px solid black; padding: 2px; width: fit-content;">Meter size 25 mm</div>	Read-only parameter. DN3 to DN100 (1/10 to 4 in.)
	<div style="border: 1px solid black; padding: 2px; width: fit-content;">Span Cs. 6.25 Hz 52.93%</div>	Read-only parameter.
	<div style="border: 1px solid black; padding: 2px; width: fit-content;">Zero Cz. 6.25 Hz 0.0142%</div>	Read-only parameter.
	<div style="border: 1px solid black; padding: 2px; width: fit-content;">Short model no. DX4000</div>	Read-only parameter.
	<div style="border: 1px solid black; padding: 2px; width: fit-content;">Order no. 97W87631</div>	Read-only parameter.

**10DX4311 MAGNETIC FLOWMETER INSTRUCTION MANUAL**

Submenu / Parameter	Entry mode	Description
<div style="border: 1px solid black; padding: 2px; width: fit-content;">                     Cal-fact    10 m/s                      150.00    l/min                 </div>	read-only	Automatic selection.
<div style="border: 1px solid black; padding: 2px; width: fit-content;">                     Range                      400.000    m3/h                 </div>	numeric	Measuring range for forward- and reverse flow Minimum allowable range adjustable between 0 - 1.6 ft/s (0 - 0.5 m/s). Maximum allowable range adjustable between 0 - 33 ft/s (0 - 10 m/s). Upper range limit is adjustable between 1.6 and 33 ft/s (0.5 and 10 m/s).
<div style="border: 1px solid black; padding: 2px; width: fit-content;">                     Pulse Factor                      1.0000    /m3                 </div>	numeric	For internal and external flow totalling, range 0.001- 1000 pulses per selected unit, maximum counting frequency 5 kHz.
<div style="border: 1px solid black; padding: 2px; width: fit-content;">                     Pulse width                      30.000 ms                 </div>	numeric	For external pulse output, range 0.1 ms - 2000 ms.
<div style="border: 1px solid black; padding: 2px; width: fit-content;">                     Low flow cut-off                      1.000 %                 </div>	numeric	Range 0 - 10 %, sets display and all outputs
<div style="border: 1px solid black; padding: 2px; width: fit-content;">                     Damping                      10.0000 s                 </div>	numeric	Range 0.5 - 99.9999 s, response time for 0 - 99 % flow change.
<div style="border: 1px solid black; padding: 2px; width: fit-content;">                     Filter                      on                 </div>	tabular	On/off. Defaults to "OFF". When noisy output signal is present turn noise reduction filter "ON" and select a damping time > 2.4 s.
<div style="border: 1px solid black; padding: 2px; width: fit-content;">                     Density                      2.54300    g/cm3                 </div>	numeric	Range 0.01 - 5 g/cm <sup>3</sup> . Determines flow rate for display and totalizing in g, kg, t, ton or pound.
<div style="border: 1px solid black; padding: 2px; width: fit-content;">                     System-zero Adjust                      3.5 Hz                 </div>	tabular	Zero check (required for use with older primaries).  Exit submenu.
<div style="border: 1px solid black; border-radius: 50%; width: 30px; height: 30px; display: flex; align-items: center; justify-content: center;">                     ENTER                 </div>	<div style="border: 1px solid black; padding: 2px; width: fit-content;">                     System-zero Adj.                      manual                 </div>	Manual value entry
	<div style="border: 1px solid black; padding: 2px; width: fit-content;">                     System-zero Adj.                      automatic                 </div>	Valve must be closed. There must be no fluid flow. Press ENTER to initiate the automatic adjustment.



10DX4311 MAGNETIC FLOWMETER INSTRUCTION MANUAL

Submenu / Parameter	Entry mode	Description
<div style="border: 1px solid black; padding: 2px; width: fit-content;">Submenu unit</div>	tabular/numeric	<div style="border: 1px solid black; border-radius: 50%; width: 20px; height: 20px; display: flex; align-items: center; justify-content: center; margin-bottom: 5px;">C/CE</div> Exit submenu
<div style="border: 1px solid black; border-radius: 50%; width: 20px; height: 20px; display: flex; align-items: center; justify-content: center; margin: 0 auto;">ENTER</div>	<div style="border: 1px solid black; padding: 2px; width: fit-content;">Range Unit l/s</div>	ml/s, ml/min, ml/h, Ml/h, Ml/min, Ml/day, lbs/s, lbs/min, lbs/h, uton/min, uton/h, uton/day, l/s, l/min, l/h, hl/s, hl/min, hl/h, m <sup>3</sup> /s, m <sup>3</sup> /min, m <sup>3</sup> /h, igps, igpm, igph, mgd, gpm, gph, bbl/s, bbl/min, bbl/h, bls/day, bls/min, bls/h, kg/s, kg/min, kg/h, t/s, t/min, t/h, g/s, g/min, g/h, kgal/s, kgal/min, kgal/h.
	<div style="border: 1px solid black; padding: 2px; width: fit-content;">Totalizer unit m3</div>	ml, l, hl, ical, gal, mgal, bbl, bls, kg, t, g, Ml, lb, uton, kgal.
	<div style="border: 1px solid black; padding: 2px; width: fit-content;">Unit factor 3785.41 Liter</div>	Freely configurable flow unit, referenced to Liter; Value is valid for the unit kgal (factory preset).
	<div style="border: 1px solid black; padding: 2px; width: fit-content;">Unit name kgal /s /min /h</div>	4-character designation of the selected flow unit.
	<div style="border: 1px solid black; padding: 2px; width: fit-content;">Prog. unit without density</div>	Prog. unit for mass flow (with density) or volumetric flow (without density)
<div style="border: 1px solid black; padding: 2px; width: fit-content;">Submenu alarm</div>	tabular/numeric	<div style="border: 1px solid black; border-radius: 50%; width: 20px; height: 20px; display: flex; align-items: center; justify-content: center; margin-bottom: 5px;">C/CE</div> Exit submenu.
<div style="border: 1px solid black; border-radius: 50%; width: 20px; height: 20px; display: flex; align-items: center; justify-content: center; margin: 0 auto;">ENTER</div>	<div style="border: 1px solid black; padding: 2px; width: fit-content;">Error log 0...3...</div>	Any errors encountered (Error 0-8) are stored in the Error Register. Erase error log by pressing ENTER.
	<div style="border: 1px solid black; padding: 2px; width: fit-content;">Max-Alarm 130 %</div>	Limit alarm, range 0 - 130 % of set range.
	<div style="border: 1px solid black; padding: 2px; width: fit-content;">Min-Alarm 10 %</div>	Limit alarm, range 0 - 130 % of set range.
<div style="border: 1px solid black; padding: 2px; width: fit-content;">Submenu Prog. in/output</div>	tabular	<div style="border: 1px solid black; border-radius: 50%; width: 20px; height: 20px; display: flex; align-items: center; justify-content: center; margin-bottom: 5px;">C/CE</div> Exit submenu.
<div style="border: 1px solid black; border-radius: 50%; width: 20px; height: 20px; display: flex; align-items: center; justify-content: center; margin: 0 auto;">ENTER</div>	<div style="border: 1px solid black; padding: 2px; width: fit-content;">function X1/G2 Zero return</div>	Programmable input. Selects function of X1 input terminal (G2 is common). Refer to Section 6.14.1 and Figure 3-13.
	<div style="border: 1px solid black; padding: 2px; width: fit-content;">function P7/G2 General alarm</div>	Programmable output. Selects function of P7 output terminal (G2 is common). Refer to Section 6.14.2 and Figure 3-13.

# 10DX4311 MAGNETIC FLOWMETER INSTRUCTION MANUAL

Submenu/Parameter	Entry mode	Description
<div style="border: 1px solid black; padding: 2px; margin-bottom: 10px;">                     Submenu ----- current output                 </div> <div style="text-align: center; margin-bottom: 10px;">                     ENTER                 </div>	<p style="text-align: center;">tabular</p> <div style="border: 1px solid black; padding: 2px; margin-bottom: 5px; text-align: center;">                     Current output ----- 0 - 20 mA                 </div> <div style="border: 1px solid black; padding: 2px; margin-bottom: 5px; text-align: center;">                     lout at alarm ----- 130 %                 </div>	<p style="text-align: center;">C/CE</p> <p>Exit submenu.</p> <p>Select current output 0-20 mA / 4-20 mA, 0-10 mA / 2-10 mA, 0-5 mA / 0-10, 10-20 mA / 4-12, 12-20 mA</p> <p>Select current output for error condition, 0/4 mA or 0/26 mA. For Error Code 3 "flow rate &gt; 130 %", current output is always 26 mA.</p>
<div style="border: 1px solid black; padding: 2px; margin-bottom: 10px;">                     Submenu ----- function test                 </div> <div style="text-align: center; margin-bottom: 10px;">                     ENTER                 </div>	<p style="text-align: center;">tabular/numeric</p> <div style="border: 1px solid black; padding: 2px; margin-bottom: 5px; text-align: center;">                     Function test ----- lout                 </div> <div style="border: 1px solid black; padding: 2px; margin-bottom: 5px; text-align: center;">                     Function test ----- NVRAM                 </div>	<p style="text-align: center;">C/CE</p> <p>Exit submenu.</p> <p>Function test current output, data entry in mA. Function test Fout, data entry in Hz.</p> <p>Function test int. assemblies, auto-test. NVRAM, EPROM, EEPROM. Additional functions: Alarm-contact, G2, P7-contact, switch S206, data link, display, external cut-off and totalizer reset</p>
<div style="border: 1px solid black; padding: 2px; margin-bottom: 10px;">                     Submenu ----- detector empty pipe                 </div> <div style="text-align: center; margin-bottom: 10px;">                     ENTER                 </div>	<p style="text-align: center;">tabular/numeric</p> <div style="border: 1px solid black; padding: 2px; margin-bottom: 5px; text-align: center;">                     * Error * ----- not available                 </div> <div style="border: 1px solid black; padding: 2px; margin-bottom: 5px; text-align: center;">                     Detector empty pipe ----- on                 </div> <div style="border: 1px solid black; padding: 2px; margin-bottom: 5px; text-align: center;">                     Alarm Empty Pipe ----- on                 </div> <div style="border: 1px solid black; padding: 2px; margin-bottom: 5px; text-align: center;">                     lout at Empty Pipe ----- 0%                 </div> <div style="border: 1px solid black; padding: 2px; margin-bottom: 5px; text-align: center;">                     Threshold ----- 2300 Hz                 </div> <div style="border: 1px solid black; padding: 2px; margin-bottom: 5px; text-align: center;">                     Adjustment ----- detector empty pipe                 </div>	<p style="text-align: center;">C/CE</p> <p>Exit submenu.</p> <p>Automatic identification, module not available.</p> <p>off = Detector inactive on = Empty pipe condition indicated in display and via contact.</p> <p>Activates or deactivates empty pipe alarm.</p> <p>Selects output current during empty pipe alarm (if enabled) - Selections: 0%, 3.8mA or 130%.</p> <p>Module available. Fill meter pipe with product. Set adjustment value to +2000 Hz. Drain meter pipe. Adjustment value must be above set threshold.</p>

Submenu/Parameter	Entry mode	Description
<div style="border: 1px solid black; padding: 2px; width: fit-content;">Submenu totalizer</div>	tabular/numeric	<div style="border: 1px solid black; border-radius: 50%; width: 30px; height: 30px; display: flex; align-items: center; justify-content: center; margin-bottom: 5px;">C/CE</div> Exit submenu.
<div style="border: 1px solid black; border-radius: 50%; width: 30px; height: 30px; display: flex; align-items: center; justify-content: center;">ENTER</div>	<div style="border: 1px solid black; padding: 2px; width: fit-content;">Totalizer — F reset</div>	The forward flow totalizer is reset by pressing ENTER. If overflow totalizer > 0, only overflow forward flow "→F" appears for reset.
	<div style="border: 1px solid black; padding: 2px; width: fit-content;">Totalizer — F 4697.00 m3</div>	Allows presetting of forward-flow Totalizer value. 2nd line of display shows the value entered.
	<div style="border: 1px solid black; padding: 2px; width: fit-content;">Overflow — F 250</div>	Shows Totalizer overflow value up to a maximum of 250. 1 overflow count = actual pulse counter value of > 9,999,999 Totalizer units. At each overflow, display is reset to 0 and overflow register is incremented
	<div style="border: 1px solid black; padding: 2px; width: fit-content;">Totalizer — R reset</div>	See forward-flow Totalizer.
	<div style="border: 1px solid black; padding: 2px; width: fit-content;">Totalizer — R 625.000 m3</div>	See forward-flow Totalizer.
	<div style="border: 1px solid black; padding: 2px; width: fit-content;">Overflow — R 004</div>	See forward-overflow counter.
	<div style="border: 1px solid black; padding: 2px; width: fit-content;">Totalizer function standard</div>	Standard = separate registration of forward and reverse flow volume by means of separate totalizers. Differential totalizer = forward and reverse flow volume are indicated in the display by one totalizer.
<div style="border: 1px solid black; padding: 2px; width: fit-content;">Submenu Display</div>	tabular	<div style="border: 1px solid black; border-radius: 50%; width: 30px; height: 30px; display: flex; align-items: center; justify-content: center; margin-bottom: 5px;">C/CE</div> Exit submenu
<div style="border: 1px solid black; border-radius: 50%; width: 30px; height: 30px; display: flex; align-items: center; justify-content: center;">ENTER</div>	<div style="border: 1px solid black; padding: 2px; width: fit-content;">1st line Q [%]</div>	Process indication: Different display outputs can be selected (separate for both display lines) for the process indication. For example Q [%], instantaneous flow in %, Q [engineering unit] instantaneous flow in engineering unit, Q [mA] instantaneous flow in mA [current output], F/R-flow, totalizer value of forward and reverse flow, tag number. Changeover to alternate process indication of 1 <sup>st</sup> display line occurs every 10 sec. if multiplex "ON" is selected.
	<div style="border: 1px solid black; padding: 2px; width: fit-content;">2nd line totalizer</div>	
	<div style="border: 1px solid black; padding: 2px; width: fit-content;">1st line multiplex off</div>	
	<div style="border: 1px solid black; padding: 2px; width: fit-content;">2nd line multiplex off</div>	

Submenu / Parameter	Entry mode	Description
<div style="border: 1px solid black; padding: 2px;">                     Submenu                      Operating mode                 </div>	tabular	 Exit submenu
		
<div style="border: 1px solid black; padding: 2px;">                     Operating mode                      standard                 </div>		Standard or Fast Standard = continuous flow measurement Fast = accelerated processing of measured values (short-time dispensing procedure or pulsating flow)
<div style="border: 1px solid black; padding: 2px;">                     Flow indication                      standard                 </div>		Change of flow direction: Standard or Opposite
<div style="border: 1px solid black; padding: 2px;">                     Flow direction                      forward/reverse                 </div>		Forward/Reverse or Forward Flow. Forward/reverse flow = measurement of both forward and reverse flow directions. Forward flow = measurement only of forward flow direction.
<div style="border: 1px solid black; padding: 2px;">                     load data from                      external EEPROM                 </div>	tabular	Allows restoring programmed data if converter replacement is necessary.
<div style="border: 1px solid black; padding: 2px;">                     store data in                      external EEPROM                 </div>	tabular	After start-up, the actual measurement parameters can be stored in the external EEPROM located on the Display Board Assembly.
<div style="border: 1px solid black; padding: 2px;">                     50XE4000 01/98                      D699B128U01 A.28                 </div>	read-only	Shows converter model number, firmware version number and date firmware was generated.
<div style="border: 1px solid black; padding: 2px;">                     Tag number                      FQ1000                 </div>	numeric	Allows input of a Tag number with a maximum of 16 digits.
<div style="border: 1px solid black; padding: 2px;">                     Code Number                 </div>	numeric	Only for use by ABB Instrumentation service personnel.

## 7.0 PARAMETER ENTRY

After power has been turned on, programming parameters may only be changed by turning program protection "OFF". There are two ways to turn off the program protection:

1. If program protection code (PP-code) is on "0" (factory default), the program protection is turned off by pressing ENTER key.
2. If a PP-code (1 to 255) other than "0" has been entered, this code must be entered in order to turn the program protection "OFF".

The PP-code can be changed after the program protection has been turned off.

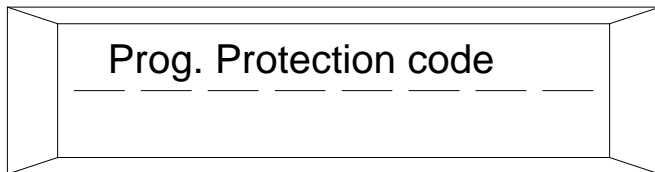

In order to be on the safe side when changing the PP-code the old PP-code must be entered after ENTER has been actuated.

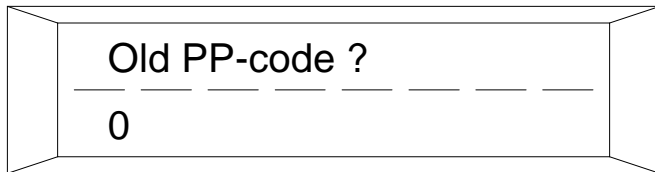

Press ENTER key after entry of old PP-code.

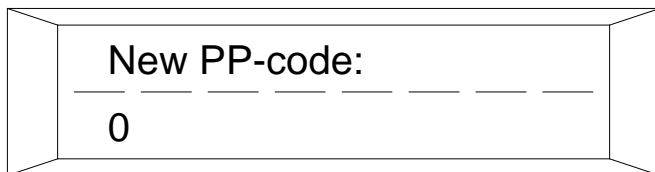

Now enter the new PP-code (0-255) and press ENTER key. The **new** PP-code is now valid to turn off the program protection.

If the PP-code is forgotten, entering the Service Code will reveal the Program Protection Code.

### NOTE

During data entry the input values are checked for acceptability. If data is not acceptable, it is rejected and a message is generated indicating that the new data has not been accepted.

### 7.1 Language Tabular Entry

The text in the display may be selected to read in nine different languages. The desired language can be selected with the arrow keys.

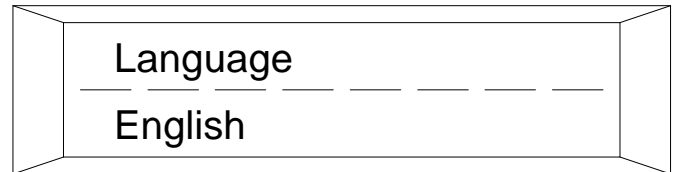

The following languages are available:

- German
- English
- French
- Italian
- Spanish
- Finnish
- Dutch
- Danish
- Swedish

### 7.2 Submenu Primary Read-only

This submenu contains information for the primary being used with the signal converter. These items are informational only and may not be changed (read-only). The indicated meter size determines the value shown in the **Cal -fact** display which follows the **Submenu Primary**.

#### 7.2.1 Meter Size

This display indicates the size of the meter's flowtube.

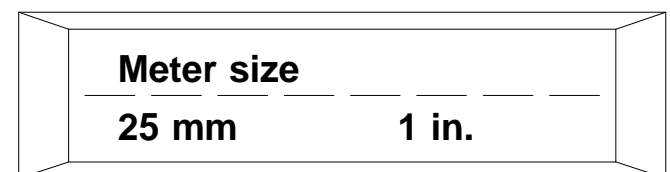

#### 7.2.2 Span Cs 7.25 Hz

The Span Cs display shows the relative span signal produced by the Primary. Cs is shown as a percentage of the nominal value that would be expected based on the level of coil excitation current applied. A typical display is shown below.



Span Cs 7.25 Hz
-----------------

52.35 %
---------

### 7.2.3 Zero Cz 7.25 Hz

The Zero Cz display is a measure of the zero offset produced by the Primary. A typical display is shown below. The Signal Converter uses both the Cs and Cz values to generate offset-free outputs normalized to the size of the Primary.

Zero Cz 7.25 Hz
-----------------

0.0212 %
----------

### 7.2.4 Short Model Number

The short model number display shows one of the generic Primary types intended for use with the M2 Signal Converter. This would also include the DM2 and DM3 series of meters.

Short model no.
-----------------

DX4000
--------

### 7.2.5 Order Number

The order number is the ABB Instrumentation serial number of the signal converter. This number is generated by the factory and is unique to the instrument.

Order no.
-----------

97W87631
----------

## 7.3 Calibration Factor

Cal-fact	10 m/s
----------	--------

150.00	l/min
--------	-------

In order for the converter to produce the proper flow rate output(s), calibration information from the associated flowmeter must be known. This information has been determined at the factory and is entered in the converter non-volatile memory as "Cal-Factor". The Cal-Factor is determined as the amount of flow necessary to produce a converter velocity signal of 10 meters/second. The flowmeter is factory calibrated so that the flow rate which produces this velocity is a fixed value ("constant meter factor per size") as a function of meter size.

The calibration factor is the base upon which the flow computer establishes maximum and minimum limits for range settings and outputs.

## 7.4 Range

### Numeric entry

A maximum flow rate range value can be entered between the limits of  $0.05 \times \text{Cal-factor}$  and  $1.0 \times \text{Cal-factor}$ .

Range	
-------	--

400.000	m3/h
---------	------

The selection is made with the STEP and DATA buttons. The unit is selected in Section 7.12.

For Totalizer operation, the set measuring range is checked by the computer as a function of **the pulse factor** (between 0.01 and 1000 pulses/unit), **the pulse width** (between 0.1 and 2000 ms), **the totalizer unit** (e.g. ml, l, m<sup>3</sup>) or **mass unit** (e.g. g, kg, t) with **the density correcting value**.

If one of these parameters is changed, the pulse width may be automatically recalculated to be a maximum of 50% of the period of the output frequency at 100% flow rate (duty-cycle [on/off ratio] = 50%) and following message is displayed.

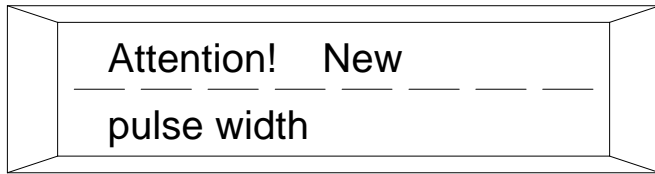

If the ratio of the output frequency is too low, the following message is displayed:

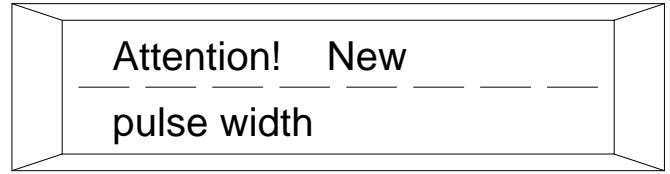

If the ratio of the output frequency is too low, the following message is displayed:

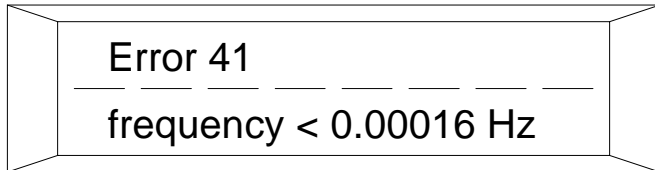

If the ratio of the output frequency is too high, the following message is displayed:

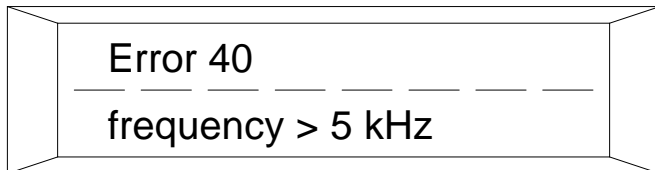
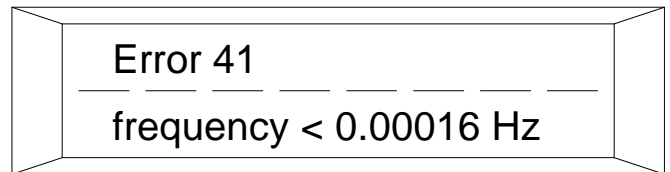

### 7.5 Pulse factor Numeric entry

The pulse factor is the number of pulses for one flow rate unit for the pulse output and the internal totalization and applies to forward as well as reverse flow.

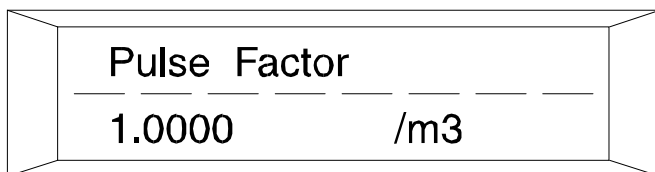

When the pulse factor is changed the totalizer value remains in the correct unit as selected per section 7.12.2 .

The pulse factor can be selected between 0.001 and 1000 pulses/unit. The selected pulse factor is checked by the computer as a function of **the pulse factor** (between 0.01 and 1000 pulses/unit), **the pulse width** (between 0.1 and 2000 ms), **the totalizer unit** (e.g. ml, l, m<sup>3</sup>) or **mass unit** (e.g. g, kg, t) with **the density correcting value**. If one of these parameters is changed, the pulse width may be automatically recalculated to be a maximum of 50% of the period of the output frequency at 100 % flow rate (duty-cycle [on/off ratio] = 50%) and following message is displayed.

### 7.6 Pulse Width Numeric entry

The pulse width (pulse duration) for the scaled pulse output can be selected between 0.1 and 2000 ms. For technical reasons the actual pulse width in the converter is always a multiple of 0.05 ms. The selected pulse width must be short enough to avoid pulses overlapping at the maximum output frequency (maximum flow 130 % = 7.5 kHz) but long enough to guarantee activation of the pulse counter being used.

#### Example:

Flow range = 100 l/min (Q<sub>max</sub> = 100 % range end value)

Totalizer = 1 pulse/l

$$f = \frac{100 \text{ pulses/min}}{60 \text{ s}} = 1.666 \text{ Hz}$$

#### At 30% overrange:

$$f = 1.666 \text{ Hz} \cdot 1.3 = 2.166 \text{ Hz } (^1/s)$$

#### At 50% duty-cycle (on time = off time)

$$\text{Pulse width } t_p = \frac{1}{2.166 \text{ s}^{-1}} \cdot 0.5 = 230 \text{ ms}$$

A value of < 230 ms can be set here. **Mechanical counters require a pulse width of ≥ 30 ms.**

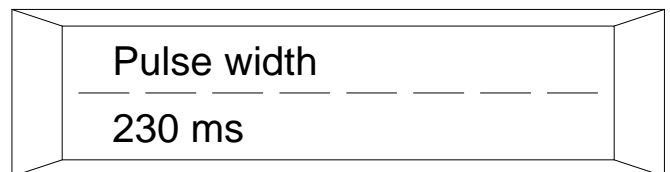

The computer automatically checks the set pulse width. The pulse width may be 80% of the output frequency at 130% of flow rate. If this limit is exceeded,

the new value will not be accepted and following error message is displayed:

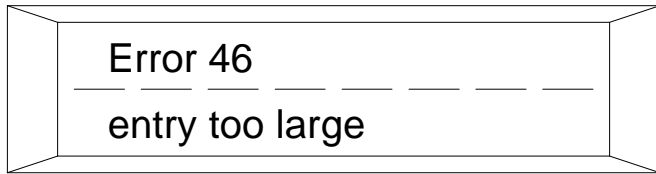

### 7.7 Low Flow Cut-Off Numeric Entry

The low flow cut-off can be selected between 0 and 10.0 % of the range end value.

Flows less than the cut-off value are not totalized. The current and pulse outputs are set to zero.

The switching threshold for the low flow cut-off has 1% hysteresis.

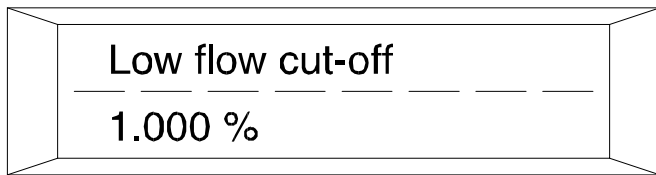

### 7.8 Damping Numeric Entry

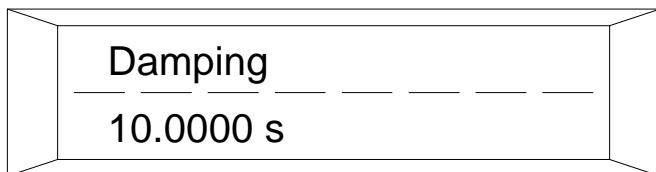

The damping value can be selected between 0.5 and 99.99 seconds. The value represents the response time for a 0 - 99 % step flow rate change.

### 7.9 Filter (Noise Rejection) Tabular Entry

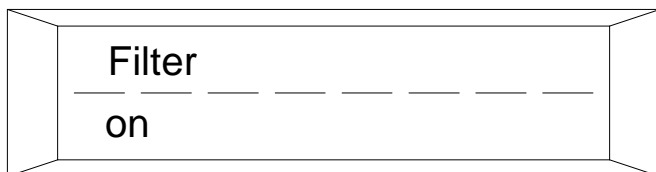

A digital filter (noise reduction algorithm) is available in the converter when pulsating flow or especially noisy signals are encountered. The digital filter improves the displayed instantaneous flow values and provides a

steady current output. With the filter turned on, the damping value may be reduced. The response time of the converter will not be influenced.

With one of the arrow keys the filter is turned on and is accepted by pressing the ENTER key. The filter is only active when the selected damping time is > 2.4 s.

### Noise Reduction Example

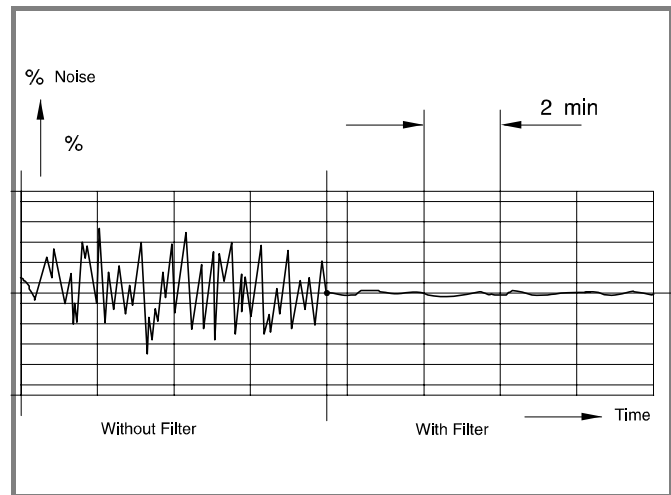

COMPARISON OF THE CONVERTER OUTPUT SIGNAL WITH AND WITHOUT NOISE REDUCTION FILTER.

### 7.10 Density Numeric entry

When the flow is totalized in gravimetric units g, kg, t, pound or USton, a density value can be entered for the calculation. The translation conversion to mass flow is settable between 0.01 and 5.00000 g/cm<sup>3</sup>. Changing the density value generates a recalculation of Range and Range DN values.

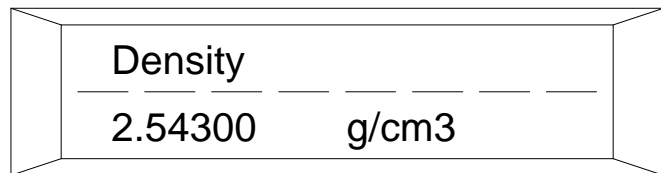

### 7.11 System Zero Numeric Entry

A zero check should be made after start up. In order to do this properly, there must be **absolutely no flow** through the meter. The zero adjust procedure can be initiated at the converter. Automatic or manual setting modes are possible.

Select parameter "System-zero Adj." and press the ENTER key.

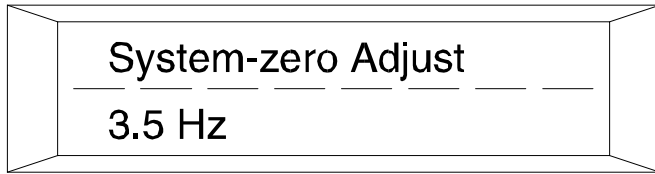

The STEP and DATA keys are used to toggle between the automatic and manual modes.

Pressing ENTER initiates the automatic zero adjustment. A countdown from 255 towards 0 on the display is repeated four times. The zero value determined by the converter must be within  $\pm 500$  Hz ( $\pm 5\%$  of Range DN). If the zero value is not within these limits no adjustment takes place. The value determined by the converter is displayed in the 2nd line of the display. Pressing the C/CE key sets the zero value to 0 Hz.

### 7.12 Submenu Unit

This submenu allows selection of units for the following parameters:

- $Q_{max}$  Engineering unit
- Totalizer Engineering unit
- Engineering unit with unit factor freely configurable
- Unit identification freely configurable
- Prog. unit with/without correcting of density

The last three parameters refer to a freely configurable unit. This function replaces the previously available fixed "kgal" unit.

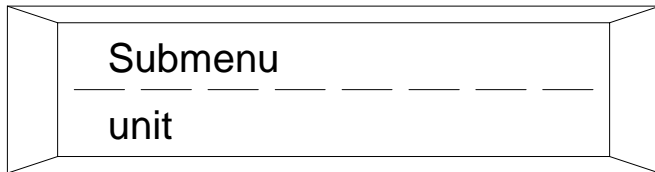

### 7.12.1 Range Unit Tabular Entry

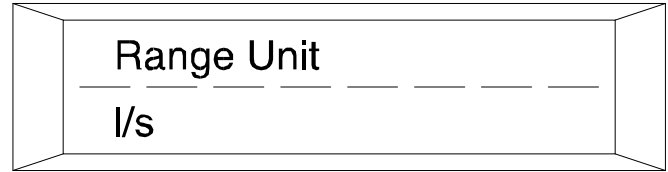

The listed units in the table below can be set with the STEP and DATA buttons and are accepted by pressing ENTER. Some units may not be available if the HART Protocol option is selected (Refer to Table 2-3)

Unit	
Liter	l/s l/min l/h
Hectoliter	hl/s hl/min hl/h
Cubicmeter	m <sup>3</sup> /s m <sup>3</sup> /min m <sup>3</sup> /h
Imperial-gallon per	igps igpm igph
U.S.-million-gallon per	mgd
U.S.gallon per	gpm gph
Barrel-Brewery [31 gallons]	bbbl/s bbbl/min bbbl/h
Barrel- Petro chemistry [42 gallons]	bls/day bls/min bls/h
Kilogram	kg/s kg/min kg/h
Ton (metric)	t/s t/min t/h
Gram	g/s g/min g/h
Milliliter	ml/s ml/min ml/h
Megaliter	MI/min MI/h MI/day
Pound (454 g)	lb/s lb/min lb/h
US-Ton	uton/min uton/h uton/day

The unit refers to  $Q_{max}$  DN,  $Q_{max}$  forward flow,  $Q_{max}$  reverse flow and the instantaneous value display if these are displayed with engineering unit.

### 7.12.2 Totalizer Unit Tabular Entry

The units listed below are available for the flow Totalizer. They can be selected with the DATA and STEP buttons. The units can be different from those selected for the flow modes. The engineering unit is accepted by pressing ENTER.

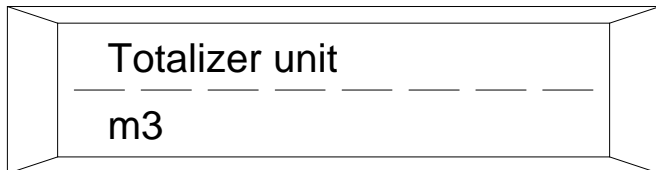

**Units:** ml, MI, lb, uton, kgal, l, hl, m<sup>3</sup>, igal, gal, mgal, bbl, bls, kg, t, g.

The selected engineering totalizer unit is checked by the computer as a function of **flow rate range**, the **pulse factor** (between 0.01 and 1000 pulses/unit), the **pulse width** (between 0.1 and 2000 ms) and with the **density correcting value** when a mass unit (e.g. g, kg, t) has been selected. If one of these parameters is changed, the pulse width may be automatically recalculated to be a maximum of 50% of the period of the output frequency at 100% flow rate (duty-cycle [on/off ratio] = 50%) and following message is displayed.

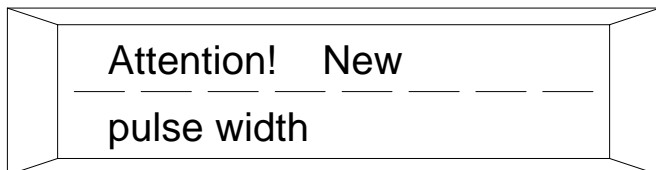

If the ratio with the output frequency is too high, following message is displayed:

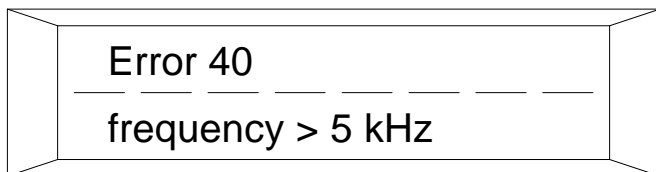

If the ratio with the output frequency is too low, following message is displayed:

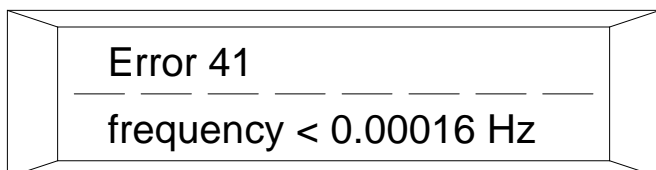

### 7.12.3 Freely Configurable Unit

This function enables configuration of any engineering unit in the converter. The following three parameters are available for this function :

- a) Unit factor
- b) Unit identification
- c) Prog. unit with / without density

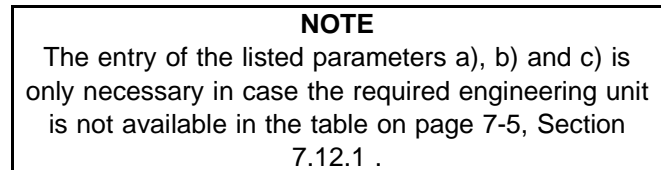

#### 7.12.3.1 Unit Factor Numeric entry

This parameter indicates the factor of the new unit with respect to one liter. The default entry is kgal=3785.41 Liter.

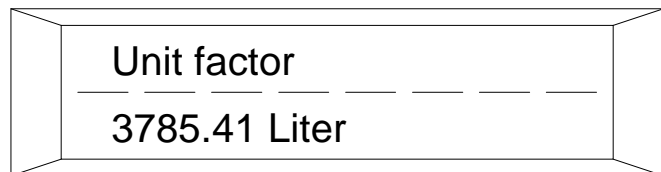

#### 7.12.3.2 Unit Designation Tabular entry

The selection is made with the STEP and DATA buttons. With DATA or the down-arrow key (↓) the alphabet is paged forward, first the lower-case letters appear and then the capital letters. The STEP or the up-arrow key (↑), controls the position and shifts the cursor to the next character position for entry. A maximum of four characters is available.

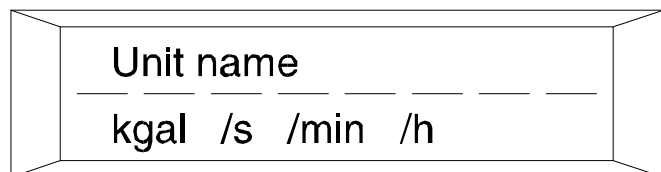

The units of time /s, /min and /h may be assigned to the engineering unit.

#### 7.12.3.3 Programmable Unit Tabular entry

This function determines whether the newly entered engineering unit is a mass unit (with density) or a

volumetric unit (without density). If density was selected, also refer to section 7.10.

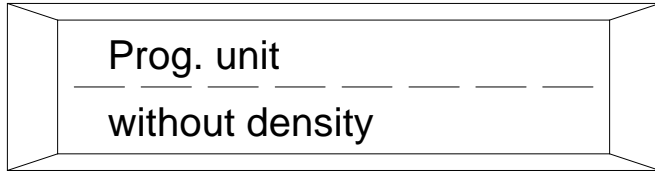

### 7.13 Submenu Alarm Tabular entry

After pressing ENTER the functions listed in this submenu can be selected with the STEP and DATA buttons.

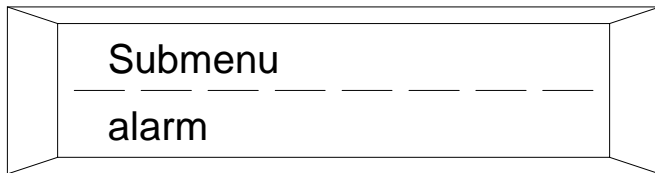

**Error register** (See Section 7.13.1)  
**MAX-Alarm** (See Section 7.13.2)  
**MIN-Alarm** (See Section 7.13.3)

#### 7.13.1 Error Log

Any errors that may have occurred (Error 0 to Error 8) are stored in this register. All detected errors remain stored until the register is manually reset (by pressing ENTER or by way of data link).

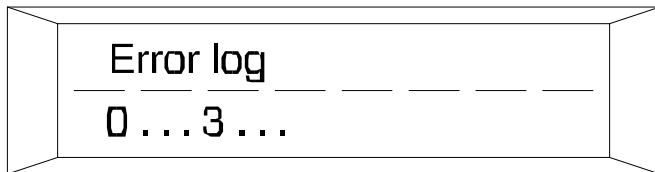

In the example shown, error 0 (empty pipe) and error 3 (flow rate > 130 %) have occurred since the last reset.

After pressing ENTER, the following is displayed:

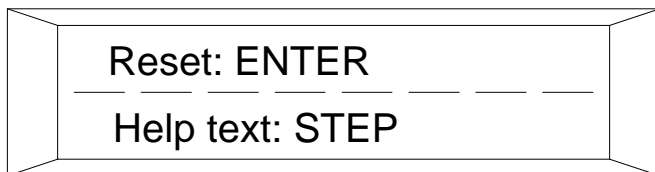

After pressing ENTER again the error register is deleted:

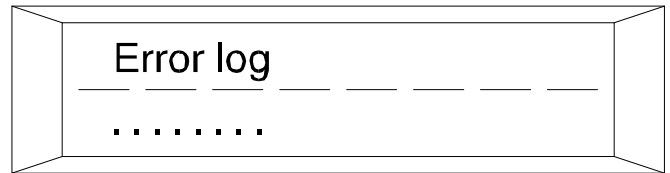

If ENTER is pressed again, the description for each error is displayed:

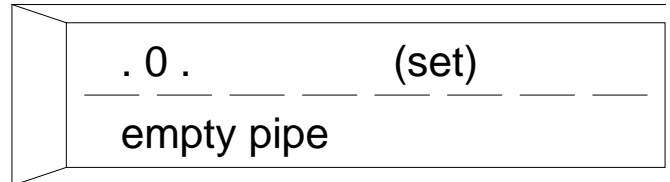

Error 0 = empty pipe.

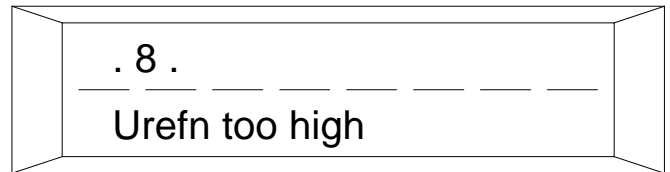

Error 8 = negative reference voltage is too high

Pressing C/CE exits the help text information.

#### 7.13.2 MAX-Alarm Numerical entry

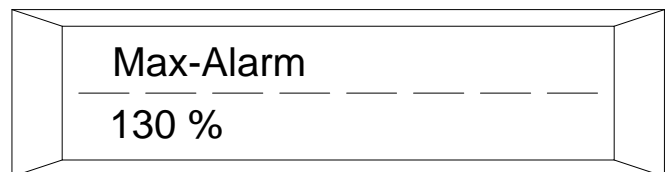

The limit of the MAX-Alarm value can be entered in 1% increments from 0% - 130%. This value is valid for both forward and reverse flow.

When the MAX-alarm value is exceeded, the alarm contacts will be actuated. This condition is also indicated on the display by means of a flashing upward-pointing arrow.

For example:

MAX-Alarm limit value = 110 %

At flow > 110 % a flashing arrow (pointing upward) appears in 1st line of the display in the position shown on the sample display.

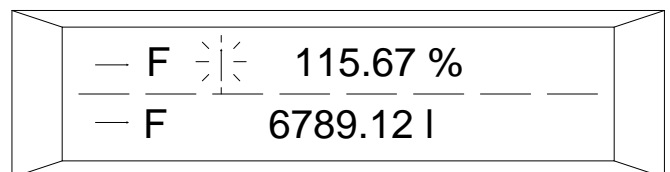

### 7.13.3 MIN-Alarm Numerical entry

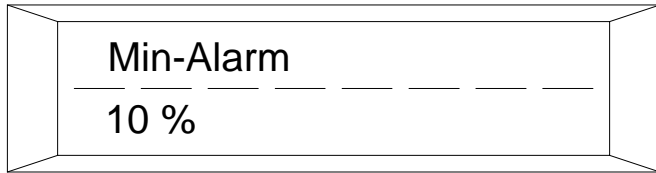

The limit of required MIN-Alarm value can be entered in increments of 1% from 0% - 130% . This value is valid for forward and reverse flow.

**NOTE**  
Switching thresholds for the MAX- and MIN-Alarms are provided with 1% hysteresis.

If a MIN-alarm occurs, the alarm contacts will be activated when the flow is less than the MIN-Alarm value. The alarm condition is also indicated on the display by means of a downward pointing flashing arrow.

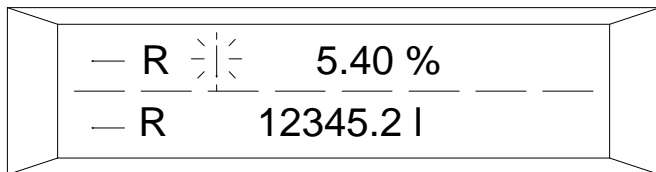

For example:  
MIN-Alarm limit value = 10 %  
At flow < 10 % a blinking arrow (pointing down) after flow direction indication appears in 1st line of the display.

### 7.14 Submenu Prog. In/Output Tabular Entry

This submenu permits configuration of the solid state contacts available at terminals X1 and P7 (circuit common is terminal G2 for both) to perform various selected functions. When configuration items have been selected as desired, they must be saved using the **Store Data in EXT EEPROM** menu selection, otherwise the configuration will be lost in the event of a power interruption.

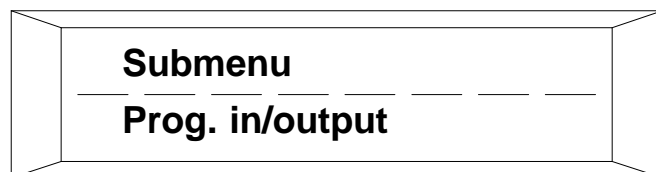

### 7.14.1 Function of Input Terminals X1/G2

The available selections for programmable input terminals **X1/G2** are:

- Zero return
- Totalizer reset
- Totalizer stop
- No function

The following is a more detailed description of the function of the available selections. Refer to Figure 3-13 for typical X1/G2 terminal wiring.

Press **ENTER** and the  $\uparrow$ **Step** button to toggle through the available parameters. Press **ENTER** to make a selection.

#### 7.14.1.1 Zero Return

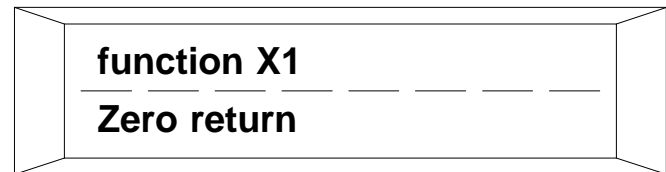

When a DC voltage is applied via a contact closure between terminals X1 & G2, all outputs will go to zero. This feature is useful when the liquid in the meter empties after the flow rate ceases.

#### 7.14.1.2 Totalizer Reset

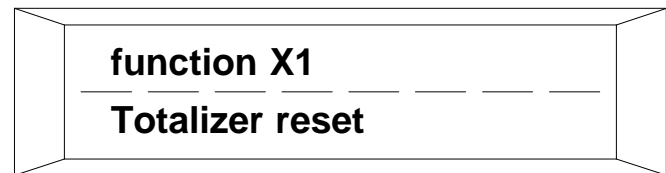

When a DC voltage is applied between terminals X1 & G2, the totalizer will reset to zero and a "Totalizer reset" message appears on the display as long as the voltage is maintained.

#### 7.14.1.3 Totalizer Stop

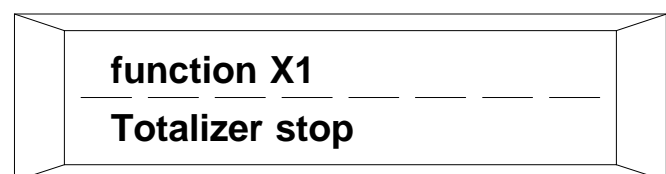

When a DC voltage is applied between terminals X1 & G2, the totalizer stops counting as long as the voltage

is maintained. If the display is configured to display the totalizer value, the totalizer's last value alternates with a "Totalizer stop" message as long as the totalizer is in the "stop" mode.

**7.14.1.4 No Function**

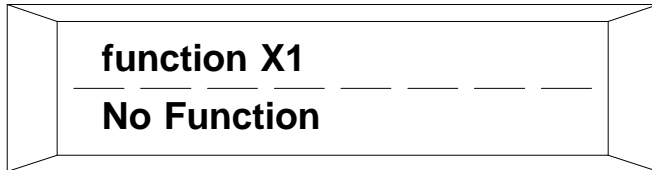

No function is assigned to terminal X1.

**7.14.2 Function of Output Terminals P7/G2**

The available selections for programmable output terminals **P7/G2** are:

- No function
- F/R-Signal
- Empty pipe (normally open or closed)
- General alarm (normally open or closed)
- MAX/MIN alarm (normally open or closed)
- Min. alarm (normally open or closed)
- Max. alarm (normally open or closed)

Normally open or normally closed contact states are indicated on the display as follows:

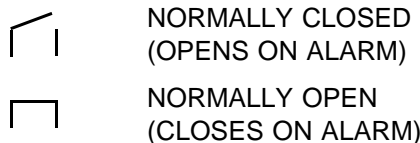

**7.14.2.1 No Function**

If module "No function" has been selected there is no signalling via terminals P7 & G2.

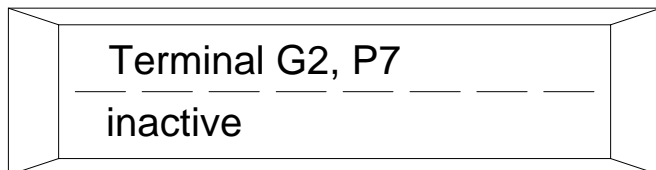

**7.14.2.2 F/R-Signal**  
**Tabular entry**

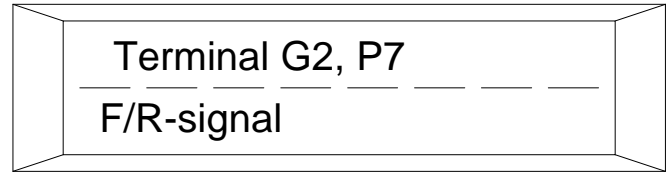

Forward and reverse flow is indicated in the display by direction arrows and through contact output P7 & G2.

**7.14.2.3 Empty Pipe**  
**Tabular entry**

With "Detector empty pipe" module installed, an empty pipe condition, with "Detector empty pipe" function enabled, will force the current output to the "no flow" condition and stop the Totalizer. The alarm output is activated and the message "Empty pipe" and "Error 0" appear on the display.

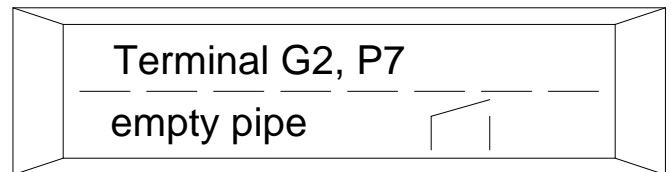

**7.14.2.4 General Alarm (error 0 to 8)**  
**Tabular entry**

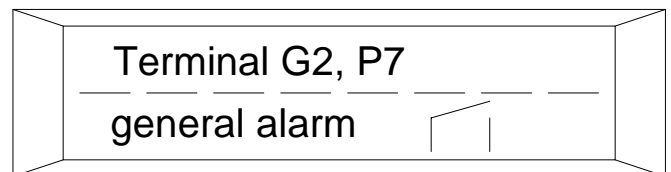

Any error that occurs (Error 0 to 8) will activate terminals P7 & G2. If an error occurs, the contacts of terminals P7 & G2 open.

**7.14.2.5 MAX/MIN-Alarm**  
**Tabular entry**

When the MAX/MIN-Alarm is desired at the P7 & G2 terminals, signalling occurs when the flow is above or below the MAX-Alarm and MIN-Alarm values respectively.

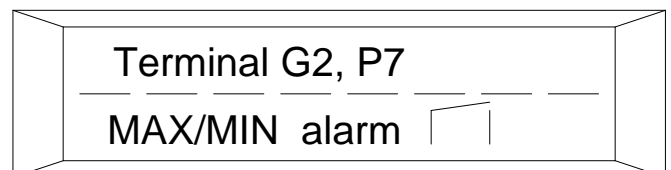



This alarm may also be configured to provide an indication of when the flow is between MIN and MAX alarm values. Setting the MIN-Alarm larger than the MAX-Alarm will provide a signal on the display as well as the P7 & G2 contacts as long as the flow is between the range settings. For example, setting the MIN-Alarm to 80% and the MAX-Alarm to 20% gives the action shown below:

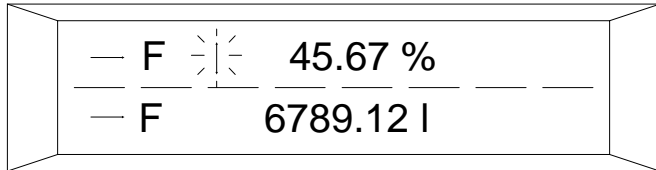

MAX-Alarm = 20 %  
 MIN-Alarm = 80 %  
 Flashing double arrow indicates flow between 20% and 80 %.

**7.14.2.6 MIN. Alarm**  
**Tabular entry**

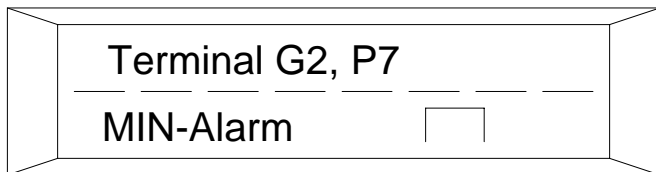

If it is desired for the terminals to signal a low-flow condition, select the MIN-alarm function must be selected for P7 & G2. The display shows the contacts **closing** for an alarm condition

For setting of the MIN alarm value, refer to Section 7.13.3.

**7.14.2.7 MAX. Alarm**  
**Tabular entry**

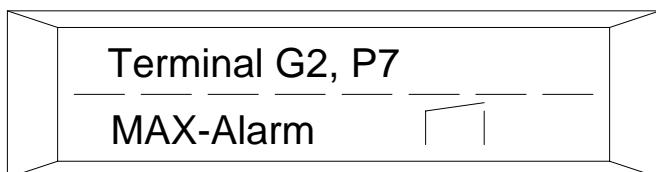

Selecting this mode will activate the output contacts if the MAX alarm value is exceeded. Contacts are shown **opening** for the alarm condition.

For setting of the MAX alarm value, refer to Section 7.13.2.

**7.15 Submenu Current Output**

The following parameters are set in the current output submenu:

- Current output
- I<sub>out</sub> at alarm.

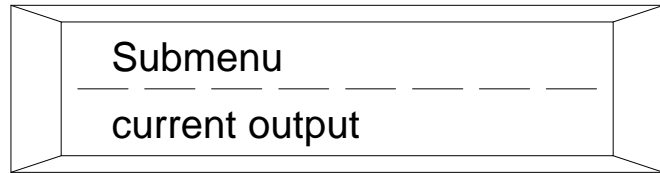

**7.15.1 Current output**  
**Tabular entry**

The following output ranges are available and can be selected with the STEP and DATA buttons.

Current output	
0-20 mA	0-5 mA
4-20 mA	0-10, 10-20 mA
0-10 mA	4-12, 12-20 mA
2-10 mA	

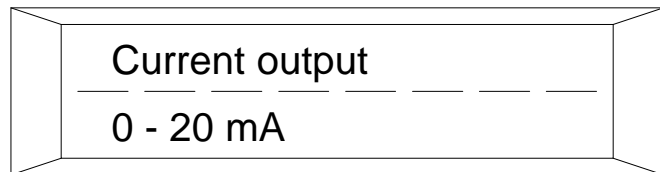

**7.15.2 I<sub>out</sub> at Alarm**  
**Tabular entry**

When an error condition is detected by the converter three things happen:

- an alarm contact output is activated
- an error message appears in the display
- the current output is set to a specified value

One of two values can be selected for the alarm current output, 0% and 130% of the Range Max. current value. For Error code 3 (flow rate > 130%), the current output is set to 130 % of the Range Max. current.

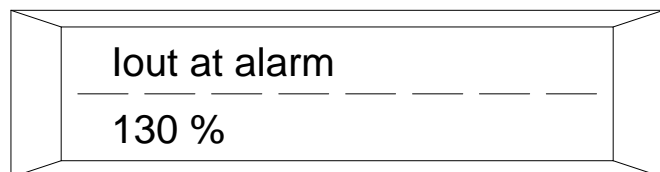

**7.16 Submenu Function Test**  
**Numeric entry only I<sub>out</sub> and F<sub>out</sub>**

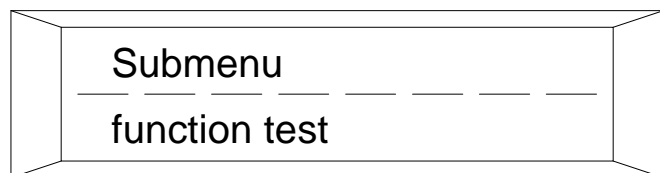

The functional test submenu provides several test functions which can be used to test the instrument independent of the instantaneous flow rate. These test functions are the following:

**I<sub>Out</sub>, NVRAM, EPROM, EEPROM, alarm contact, F/R contact, switch S206, data link, F<sub>Out</sub>, display, external zero return, totalizer reset.**

**During the functional test the converter is off-line** (current and pulse output are no longer related to the flow). The individual test routines may be selected with STEP and DATA button.

**The functional test is ended by pressing the C/CE button.**

Select **I<sub>Out</sub>**, press ENTER and enter the desired value in mA. Check entered value at terminals + and – with a digital voltmeter or with the process instruments connected to the output.

**NOTE**

The converter does not automatically return to data logging mode. To close the function press the C/CE button.

Select **NV-RAM** and press ENTER. The converter automatically tests its NV-RAM and displays its diagnosis.

Select **EPROM** and press ENTER. The converter automatically tests its **EPROM** and displays its diagnosis.

Select **EEPROM** and press ENTER. The converter automatically tests its **EEPROM** and displays its diagnosis .

Select **G2/P7 contact** and press ENTER. The contact can be turned on and off with STEP or DATA. Check with an ohmmeter across terminals P7 & G2.

Select **S206** and press ENTER. Actuate switch S206 (switch is located on the digital pc-board ). The converter displays on/off.

**Data Link Test (for factory use only).**

Select **F<sub>Out</sub>** press ENTER and enter the desired value in Hz. Check the entered value at the terminals V8 and V9.

When a positive frequency value is entered (flow rate 100% = 10 kHz), the Totalizer pulses for forward flow can be checked (note Totalizer setting; pulse factor, pulse width and Totalizer units) at terminals V8-V9. When a negative frequency value is entered (with minus sign), the totalizer pulses for reverse flow can be checked at terminals V8-V9.

Select **Display** and press ENTER. The converter writes the numbers 0 - 9 and the letters A - F in the 1st and 2nd line of the display. With that the control of the dot matrix is checked.

Select **External zero return** and press ENTER. Place a jumper across terminals X1 and G2. The converter indicates on/off.

Select **Totalizer reset** and press ENTER. Place a jumper across terminls G2 and X1. The converter indicates on/off.

**NOTE**

The converter does not automatically return to data logging mode. To close the function press the C/CE button.

**7.17 Submenu "Detector empty pipe"**

The submenu "Detector empty pipe" contains all setting programs for this option.

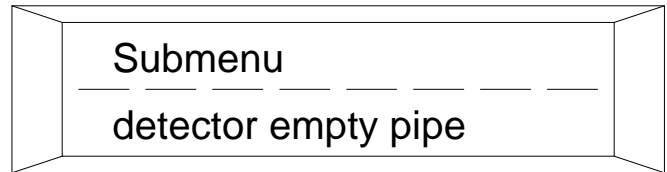

If this option is not installed in the converter, the following message is displayed:

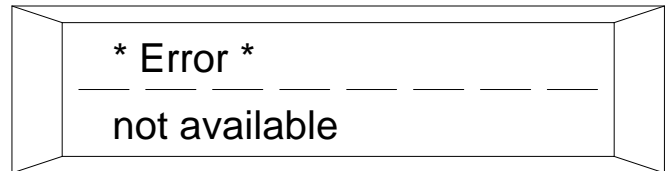

**7.17.1 Detector on/off  
Tabular entry**

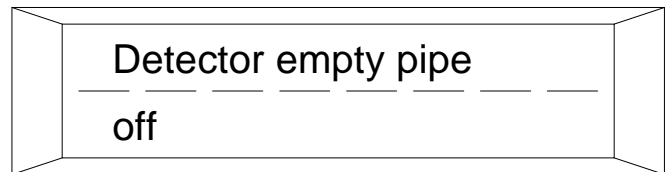

Use STEP and DATA buttons to select the on or off mode for the empty pipe detector.

An empty pipe condition with the detector empty pipe "on", will cause the current output to be set to the value selected in the "Iout at Empty Pipe" menu and the will suspend the counting of the totalizer. If enabled in the "Alarm Empty Pipe " menu below, the alarm output is actuated and the message "Empty pipe" and "Error 0" appears in the display. When the detector is in the **on** mode and the alarm is disabled with an empty pipe condition, the detector must be adjusted to the prevailing conditions, i.e. must be ad-

justed at a full pipe condition. Select parameter "Adjustment detector empty pipe " in Section 7.17.5.

### 7.17.2 Alarm Empty Pipe Tabular Entry

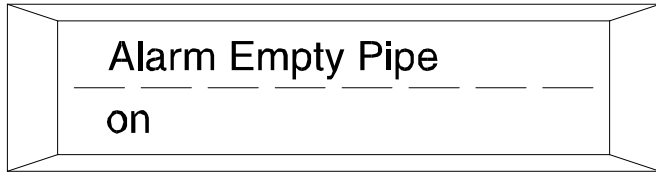

This menu parameter allows the empty pipe detector to be enabled or disabled by selecting **on** or **off** from the menu.

### 7.17.3 Iout at Empty Pipe Tabular

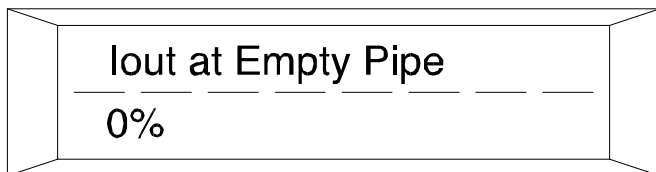

This menu selects the desired output current value if an empty pipe detector alarm condition is detected. Selection parameters are 0% of Range, 130% of Range or 3.8 mA.

### 7.17.4 Threshold Numeric entry

The sensitivity is set by changing the threshold.

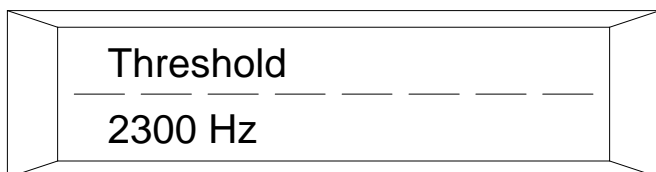

If with empty pipe condition the value 2300 Hz is not exceeded, the threshold can be reduced to 2200 Hz.

### 7.17.5 Adjustment Detector Empty Pipe - Numeric entry

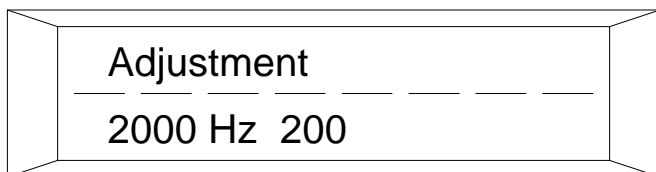

The adjustment value is displayed in the 2nd line. The pipe line must be full. With with the STEP or DATA button set adjustment value to +2000 Hz ± 25 Hz.

Now drain the pipe and note the value. The value must be above the set threshold.

**NOTE**  
For proper function of "Detector empty pipe" the minimum conductivity of the fluid must be 20 μS/cm.

### 7.18 Submenu Totalizer

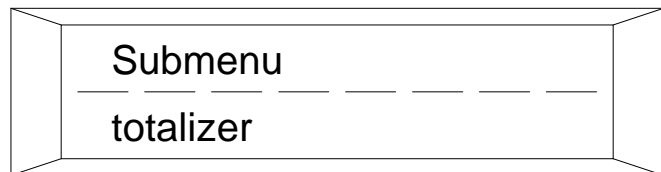

This submenu contains the following functions:

- Totalizer value forward or reverse flow and reset of overflows (Refer to Section 7.19.1)
- Totalizer functions (Refer to Section 7.19.2)
- Multiplex display (Refer to Section 7.19.3)

#### 7.18.1 Totalizer Value Reset,Overflows, Presetting of Totalizer and Tabular/Numeric entry

The Totalizers and overflow registers for each flow direction can be individually reset by pressing ENTER. First the overflow registers are reset (if available) and, after pressing ENTER again, the Totalizers are also reset. If the Totalizers have overflowed, the flow direction arrow and the units in the display will be flashing. The software allows up to 250 overflows of the internal Totalizer. At an overflow (Totalizer value > 10,000,000 units), the Totalizer will be reset and the overflow Totalizer will be incremented by one. If more than 250 overflows are counted, the message "Overflows > 250" appears in the display.

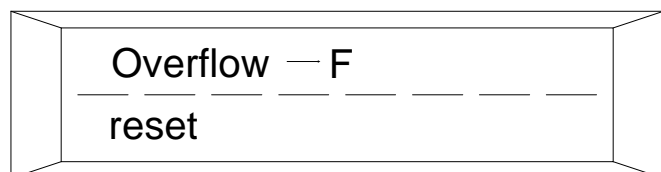
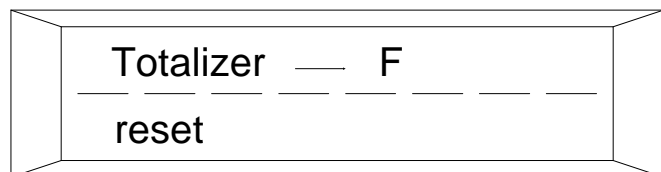

The Totalizer for "Forward flow" direction can be preset to an arbitrary value. If the converter is replaced, the new converter can be preset with the old converter's Totalizer value. Initiate the parameter (Total-

izer >F/<R) with the arrow keys. The 2nd line of the display shows the present Totalizer value. After pressing ENTER, the previous Totalizer value may be entered and, by pressing ENTER again, will be accepted by the electronics.

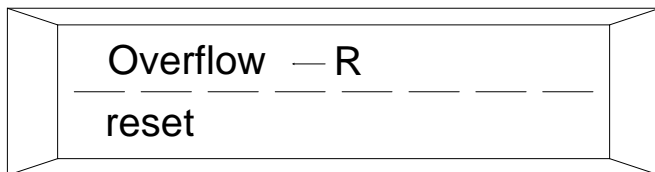
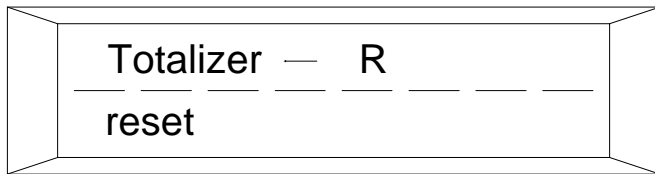
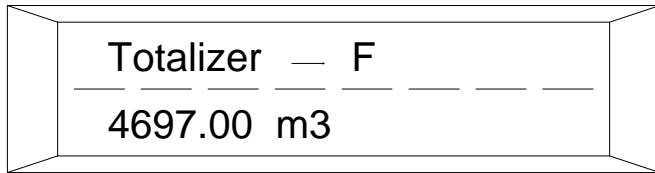

The Totalizer for "Reverse flow" direction can also be preset, for entry see "Totalizer forward" flow direction.

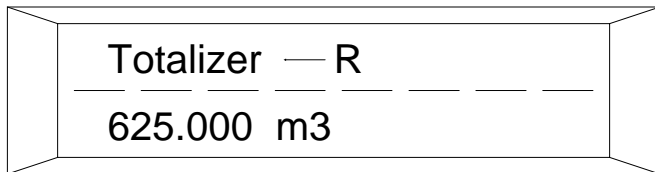

**Example calculation for overflow**

Overflow 012		
12 x	10,000,000	units
=	120,000,000	units
+	23,455	actual totalizer value
	120,023,455	units

**Max. Totalizer value**

250 x	10,000,000	units
=	2,500,000,000	units

If the function "External totalizer reset" is selected, the totalizer and overflow values are reset via contacts X1 & G2. The following message is then displayed:

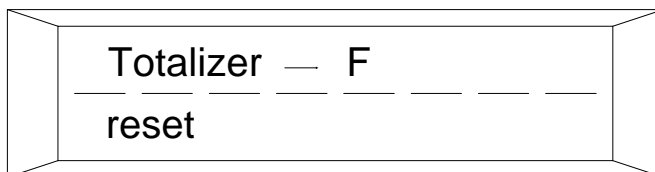

**7.18.2 Totalizer Function Tabular Entry**

Two operating modes are possible with the flow totalizer:

- Standard totalizer
- Differential totalizer.

**7.18.2.1 Totalizer Function Standard**

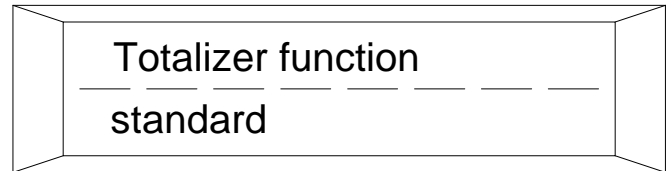

The "Totalizer Function Standard" integrates the flow rate pulse for forward or reverse flow in two different totalizers. If only the forward flow direction is selected, only the forward flow Totalizer counts. The selection is made with the STEP and DATA buttons and will be accepted with ENTER.

**7.18.2.2 Totalizer Function Differential Totalizer**

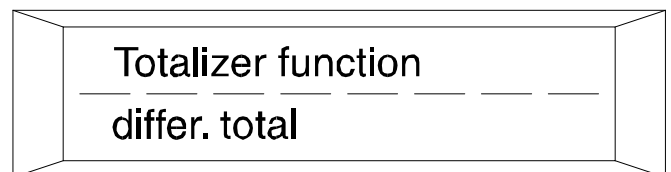

For differential totalization of both flow directions only one common internal totalizer is available. During forward flow, the Totalizer value is incremented. During reverse flow, the Totalizer value is decremented. The passive pulse output is not affected by this setting.

**7.19 Submenu Display Tabular Entry**

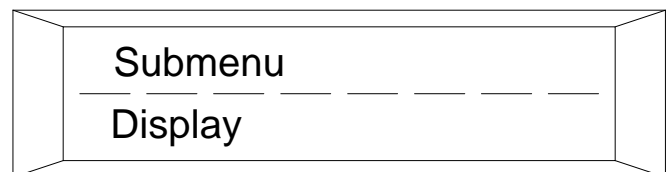

The Submenu Display parameters can be configured by selecting the appropriate parameters listed below and entering the desired information. The display may be configured so that any available information may be placed on either first or second line of the display.

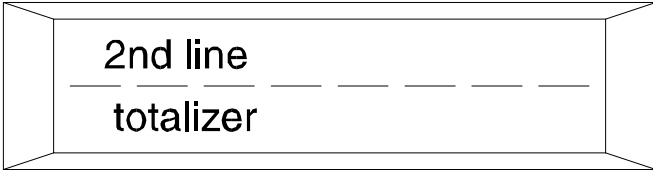
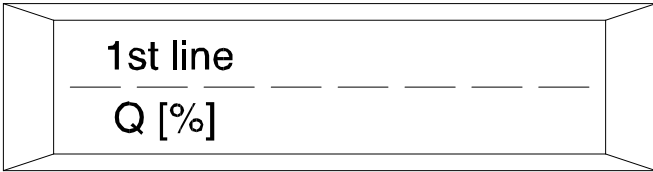

In addition, a **multiplex feature** is available which can alternate any of two sets of parameters on either line of the display. This feature can be activated by turning ON the line(s) of the display desired for multiplexing and then selecting the desired parameter to be shown. The display will alternate between the display value and the multiplex value approximately every 7 seconds.

Press ENTER at the Submenu Display and press the STEP or DATA buttons until the following screen appears:

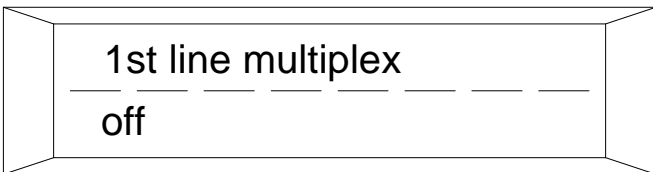

Press ENTER and the following parameters may be selected for the first line of the display by pressing the STEP or DATA buttons:

- **off**
- **Q [Bargraph]** - left to right graphic representation of flow rate as a percentage of range, with numeric percentage to the right of the bar graph
- **TAG number**
- **Totalizer - ←R** totalized flow for reverse direction only
- **Totalizer - →F** totalized flow for forward direction only
- **Totalizer** - totalized flow for the direction currently indicated on the flow rate display
- **Q [mA]** - flow rate expressed as the number of mA present at the + and – analog output terminals
- **Q [unit]** - flow rate in actual selected units
- **Q [%]** - flow rate as a percentage of range setting

If desired, a multiplexed parameter for the second display line can also be chosen from the above list by selecting from the "2nd line multiplex" menu.

## 7.20 Submenu Operating Mode Tabular Entry

This submenu enables selection of several operating parameters

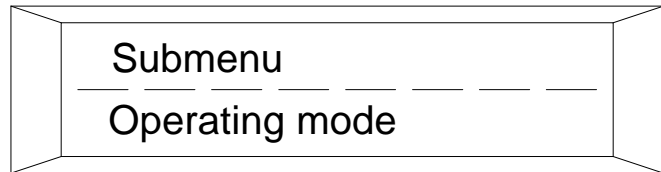

### 7.20.1 Operating Mode Tabular Entry

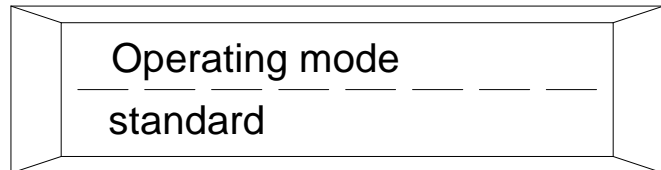

Selection of one of the two operating modes can be made using the arrow keys.

Select "**Standard**" operating mode for continuous flow measurement.

Select "**Fast**" operating mode for short-time dispensing < 3 sec. and for piston pump operations, when the converter is equipped with a higher excitation frequency .

In the "**Fast**" operating mode an improved reproducibility during a shorter measuring time is achieved by more rapid data update.

Pressing the ENTER key accepts the entry.

### 7.20.2 Flow Indication Tabular entry

The arrow on the primary indicates the flow direction

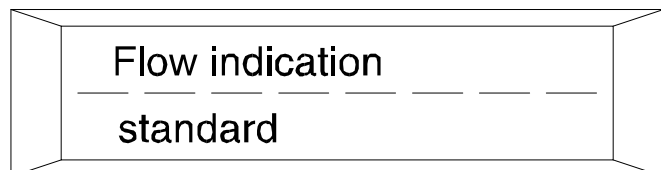

and defines the meter's forward-flow direction. If the forward direction is displayed when the flow is in the reverse direction, the direction may be interchanged using the Flow Indication selection (shown above) by selecting "Opposite".

With one of the arrow keys select the appropriate entry and press ENTER to accept.

### 7.20.3 Flow Direction Tabular Entry

This menu allows flow to be indicated in either forward and reverse directions or in the forward direction only.

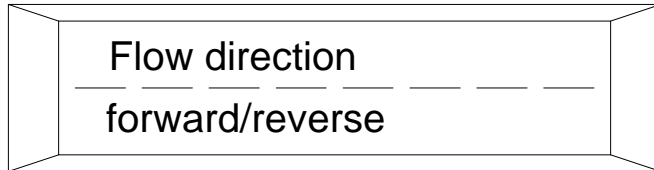

After pressing ENTER at the Submenu Operating Mode, scroll to the Flow Direction menu using either the STEP or DATA buttons.

Pressing ENTER allows changing of the "Flow Direction" setting by using the STEP or DATA buttons.

### 7.21 Load Data From External EEPROM

Allows restoring programmed data if converter replacement is necessary.



### 7.22 Store Data In External EEPROM

After start-up, the actual measurement parameters can be stored in the external EEPROM located on the Display Board Assembly.



### 7.23 Software Version

The model number is displayed on the first line of the display and the revision level of the software is displayed on the second line.

This is a read-only parameter and cannot be changed. A typical display is shown below.

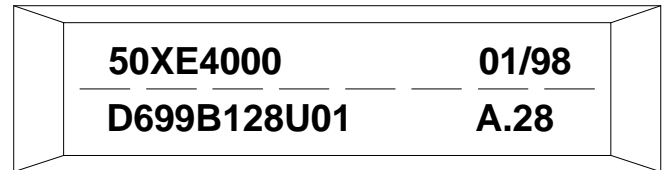

### 7.24 Service Code Number Numeric entry

The code number parameter provides a means to access the calibration parameters. Available for use only by ABB Instrumentation Service personnel.

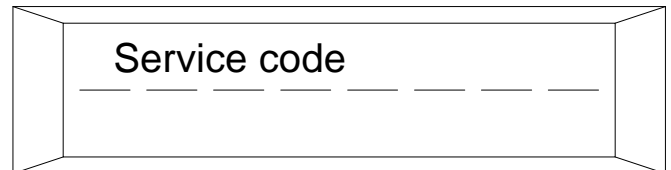

In the event the Program Protection code is forgotten, entry of the Service Code will reveal the number.

## 8.0 BLOCK DIAGRAM

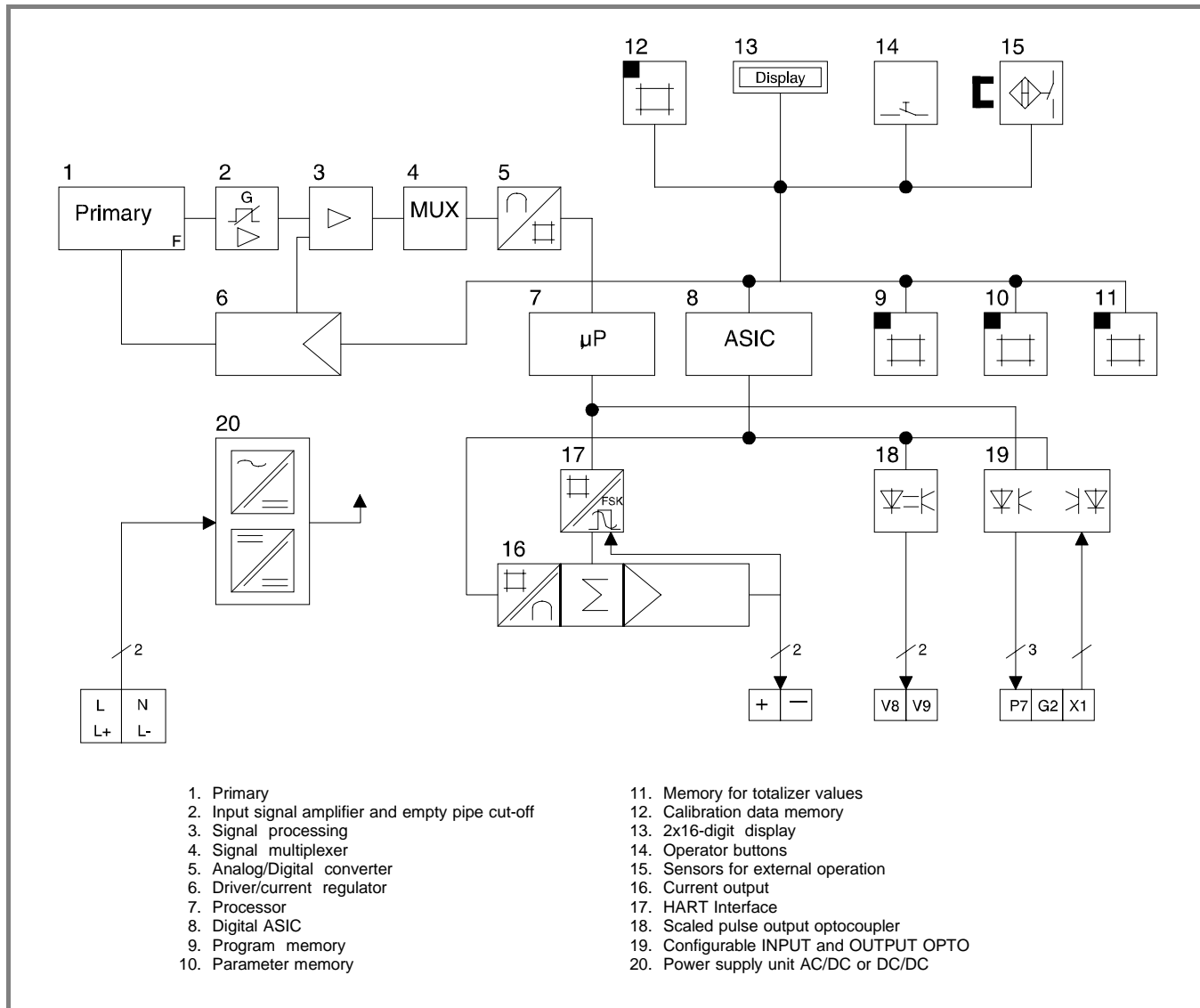

FIGURE 8-1. BLOCK DIAGRAM OF COPA-XE

## 9.0 TECHNICAL DATA

### 9.1 Meter Size, Pressure Rating, Measuring Range and Flow Rate Nomograph

**Table 9-1**

Meter Size		Min. Meas. Range flow velocity = 0 to 1.64 ft/s GPM	Max. Meas. Range flow velocity = 0 to 32.8 ft/s GPM
in.	DN		
6	150	0 to 52.8	0 to 1,057
8	200	0 to 133	0 to 2641
10	250	0 to 238	0 to 4755
12	300	0 to 397	0 to 7925
		0 to 538	0 to 10567

#### 9.1.1 Flow Rate Nomograph

The volumetric flow rate is a function of the flow velocity and the meter size of the flowmeter. The flow rate nomograph (FIGURE 9-1) indicates the flow rate range available for a specific instrument size and which size is best suited for a particular flow rate .

Note that the nomograph shows a larger range of sizes than is presently available.

#### Example:

Flow volume= 7 m<sup>3</sup>/h (maximum value= end of flow rate range). Suitable are primaries of sizes DN 20 to DN 65 for a flow velocity from 0.5 to 10 m/s.

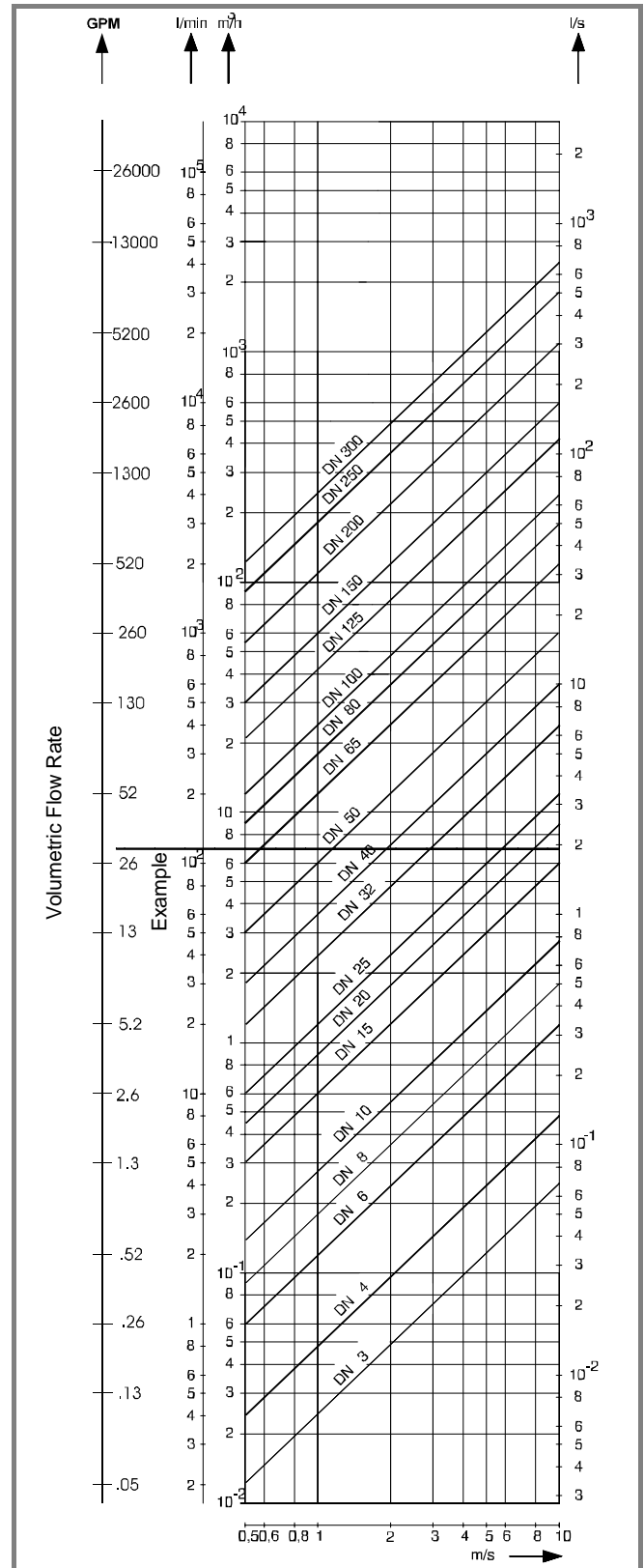

**FIGURE 9-1. FLOW RATE NOMOGRAPH - DN3 TO DN300**



## 9.2 Primary Specifications

**Table 9-2 Maximum Pressure Ratings**

FLANGE CLASS	FLANGE MAT'L	TEMPERATURE				
		≤ 100°F (38°C)	≤ 175°F (80°C)	≤ 190°F (88°C)	≤ 266°F (130°C)	≤ 356°F (180°C)
ANSI 150	Carbon Steel	285 (1.96)	260 (1.79)	255 (1.76)	235 (1.62)	215 (1.48)
	Stainless Steel	275 (1.90)	245 (1.69)	240 (1.65)	215 (1.48)	190 (1.31)
ANSI 300	Carbon Steel	740 (5.10)	690 (4.76)	680 (4.69)	660 (4.55)	640 (4.41)
	Stainless Steel	720 (4.96)	630 (4.34)	615 (4.24)	555 (3.83)	495 (3.41)
DIN PN6	Carbon Steel	87 (0.60)	87 (0.60)	87 (0.60)	86 (0.59)	82 (0.57)
	Stainless Steel	84 (0.58)	82 (0.57)	82 (0.57)	79 (0.54)	73 (0.5)
DIN PN10	Carbon Steel	145 (1.00)	145 (1.00)	145 (1.00)	145 (1.00)	145 (1.00)
	Stainless Steel	140 (0.97)	137 (0.94)	137 (0.94)	133 (0.92)	128 (0.88)
DIN PN16	Carbon Steel	232 (1.60)	232 (1.60)	232 (1.60)	232 (1.60)	232 (1.60)
	Stainless Steel	224 (1.54)	219 (1.51)	218 (1.50)	212 (1.46)	205 (1.41)
DIN PN25	Carbon Steel	362 (2.50)	362 (2.50)	362 (2.50)	362 (2.50)	362 (2.50)
	Stainless Steel	352 (2.43)	331 (2.28)	327 (2.25)	304 (2.10)	280 (1.93)
DIN PN40	Carbon Steel	580 (4.00)	580 (4.00)	580 (4.00)	580 (4.00)	580 (4.00)
	Stainless Steel	564 (3.89)	530 (3.65)	525 (3.62)	488 (3.36)	449 (3.10)

**Table 9-3 Temperature Ratings**

Liner material	Process Temperature	
	Min.	Max.
Hard rubber/ Soft rubber/Linatex	-13°F (- 25°C)	175°F (80°C)
Neoprene/ Polyurethane		190°F (88°C)
Teflon (PTFE) Tefzel (ETFE)		266°F (130°C)

### Temperature diagram

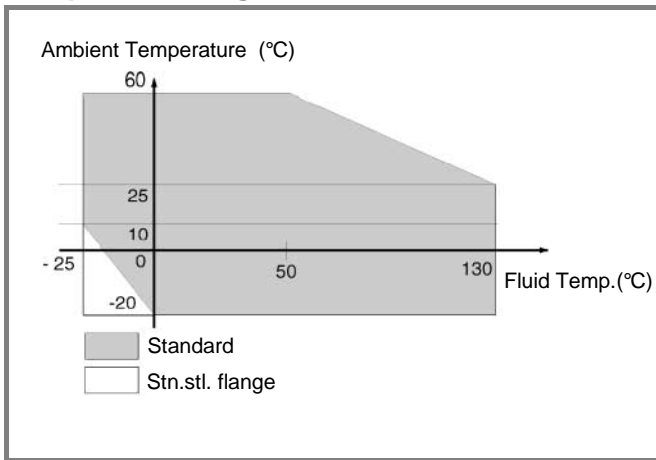

**FIGURE 9-2. FLUID TEMPERATURE vs. AMBIENT TEMPERATURE**

**Table 9-4 Maximum Cleaning Temperature**

CIP (cleaning in place)	Liner material	T <sub>max</sub>		t <sub>max</sub> Minutes	T <sub>Amb.</sub>	
		°F	°C		°F	°C
with steam	PTFE/ETFE	302	150	60	77	25
with liquid	PTFE/ETFE	302	150	60	77	25

If ambient temperature is > 25 °C, deduct difference of max. cleaning temperature. T<sub>max</sub> - Δ °C. Δ °C = (T<sub>Amb.</sub> - 25 °C)

### 9.2.1 Enclosure classification

NEMA 4X

### 9.2.2 Mechanical pipeline vibration limits

Max. allowable = 1.5G @ (10 – 150 Hz)

### 9.2.3 Explosion protection

Refer to Section 1.3 - Model Number Breakdown.

**Table 9-5 Materials, Wetted parts**

Parts	Standard	Others
<b>Liner material</b>	PTFE, ETFE, Hard rubber, Soft rubber, Neoprene, Polyurethane	-
<b>Electrode for liner material</b> - Hard rubber, Soft rubber	316 Stainless Steel	Hast. B-2, Hast. C-4, Titanium, Tantalum, Platinum-Iridium
- PTFE, ETFE	Hast.-C-4	316 Stainless Steel Hast. B-2 Titanium, Tantalum Platinum-Iridium
<b>Grounding ring</b>	316 Stainless Steel	upon request
<b>Protective flange</b>	316 Stainless Steel	upon request

**Table 9-6 Materials, Non-wetted parts**

Parts	½ in. to 4 in. (15 to 100 mm)
Housing	Two-part housing cast aluminum, painted, paint 60 µm thick, agate gray, RAL 7038
Terminal box	Cast aluminum, painted, paint 60 µm thick Frame: sky blue, RAL 5015 Lid: agate gray, RAL 7038
Meter pipe	304 Stainless Steel

**Table 9-7 Vacuum Limits**

Meter Size	Liner Material	Temperature		
		68°F (20°C)	212°F (100°C)	266°F (130°C)
6 - 12 in. (150 - 300 mm)	Teflon/Tefzel	3.0 psia	5.8 psia	6.7 psia
	Neoprene, Polyurethane,	Full vacuum to 190°F (88°C)		
	Hard rubber, Soft rubber	Full vacuum to 175°F (80°C)		

## 9.3 Converter Specifications

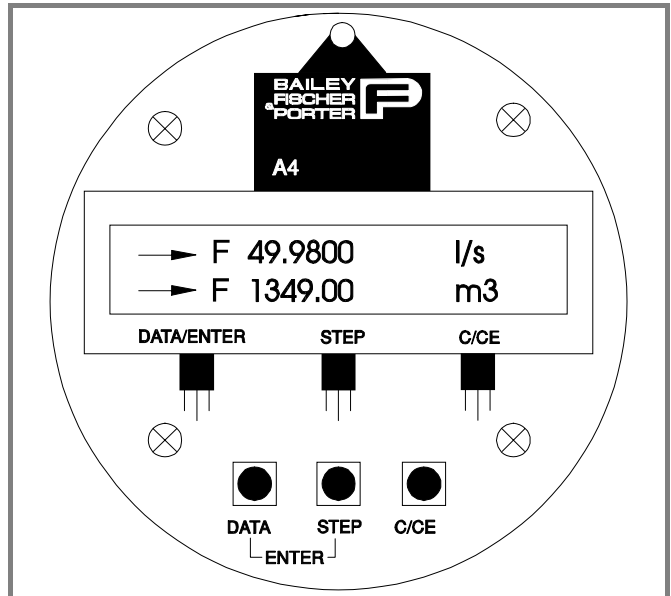

**FIGURE 9-3. CONVERTER DISPLAY AND PUSHBUTTONS**

### 9.3.1 Flow Rate Range

Continually adjustable between 0.5 and 10 m/s

### 9.3.2 Accuracy

$Q \geq 0.05 \times Q_{\max DN}$ :  $\pm 0.5$  % of rate  
 $Q < 0.05 \times Q_{\max DN}$ :  $\pm 0.00025 \times Q_{\max DN}$

### 9.3.3 Reproducibility

$\leq 0.15$  % of flow rate.

### 9.3.4 Minimum Conductivity

5 µS/cm (Contact factory for conductivities < 20 µS/cm)

### 9.3.5 Response Time

As a step function 0-99 %  $\geq 1$  s at 6 1/4, 7 1/2 Hz excitation

### 9.3.6 Power Supply

24/48/115/230 VAC, -15/+10 %, 50/60 Hz  $\pm 6$  %  
 24VDC  $\pm 30$  %, residual ripple  $\leq 5$  %

### 9.3.7 Magnet Coil Supply

Pulsed-DC excitation  
 6 1/4, 7 1/2 Hz from Converter (50/60 Hz supply)  
 Coil Current: 100 mA  
 Power to coils:  $\leq 1.3$  Watts

### 9.3.8 Power Consumption

$\leq 10$  VA (Primary and Converter)

### 9.3.9 Ambient Temperature

-20 to +60 °C (-4 to +140 °F) see temperature diagram page 9-2

### 9.3.10 Electrical Connections

- Cage-clamp terminals for wiring,
- 1/2 in. NPT internally threaded conduit fittings.

### 9.3.11 Parameter Entry

Parameter entry is possible with closed (using magnetic stick) or opened instrument.

### 9.3.12 Forward/Reverse Flow Measurement

An arrow in the display indicates the flow direction, and an optocoupler contact provides an external indication of flow direction. Signalling takes place at forward flow.

### 9.3.13 Display

LCD dot matrix display, 2 lines x16 digits. The internal flow totalizer integrates in both forward and reverse flow directions and in 15 different units. The flow volume display may be in percent or 42 different units.

For better readability, the converter housing may be rotated 90° and the display can be placed in three different positions in 90° increments.

The units listed below are set by means of the arrow buttons. The unit refers to  $Q_{maxDN}$ ,  $Q_{max}$  forward and reverse flow and to the flow volume indication, if these are displayed in engineering units.

**Table 9-8 Flow Unit Settings**

Unit Abbreviation / Description	Time Units *				with HART
	/S	/M	/H	/D	
l, liter	◆	◆	◆		◆
ml, milliliter, .001 liters	◆	◆	◆		
hl, hectoliter, 100 liters	◆	◆	◆		
Ml, megaliters, 1,000,000 l		◆	◆	◆	
m <sup>3</sup> , cubic meters	◆	◆	◆	◆	◆
igal, imperial gallon	◆	◆	◆	◆	◆
gal, US gallon		◆	◆		◆
mgal, million US gallons				◆	
bbl, brewery barrel, 31 gal.	◆	◆	◆		◆
bls, petroleum barrel, 42 gal		◆	◆	◆	
gram	◆	◆	◆		◆
kg, kilogram, 1000 grams	◆	◆	◆		◆
t, metric ton, 2000 kg		◆	◆	◆	◆
lb, US pound	◆	◆	◆		◆
uton, US ton, 2000 pounds		◆	◆	◆	
configurable unit **	◆	◆	◆	◆	◆

\* Where: /S = per second  
 /M = per minute  
 /H = per hour  
 /D = per day

**Table 9-9. Totalizer Units**

Unit Abbreviation / Description	with HART
l, liter	◆
ml, milliliter, .001 liters	
hl, hectoliter, 100 liters	
Ml, megaliters, 1,000,000 l	
m <sup>3</sup> , cubic meters	◆
igal, imperial gallon	◆
gal, US gallon	◆
mgal, million US gallons	
bbl, brewery barrel, 31 gal.	◆
bls, petroleum barrel, 42 gal	
gram	◆
kg, kilogram, 1000 grams	◆
t, metric ton, 2000 kg	◆
lb, US pound	◆
uton, US ton, 2000 pounds	
configurable unit **	◆

\*\* Name & volume may be configured by the user. Volume can be 0.001 to 4,999,999 liters. Default unit is "kgal", 1000 US gallons.

### 9.3.14 Data Security

If the power supply should fail, all data is stored in a NV-RAM for a period of more than 10 years without requiring external power. Additional data security is offered by an external serial EEPROM located in the converter for exchange or storage of process information.

### 9.3.15 Separation of Input / Output

Current and pulse output are galvanically isolated from the input circuit and from one another.

### 9.3.16 Input / Output Signals

#### 9.3.16.1 Current Output

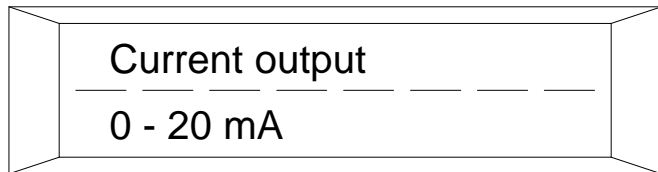

**Selectable:**

- 0/4-20 mA, load ≤ 600 Ω;
- 0/2-10 mA, load ≤ 1200 Ω;
- 0-5 mA, load ≤ 2400 Ω

**Terminals: +/-**

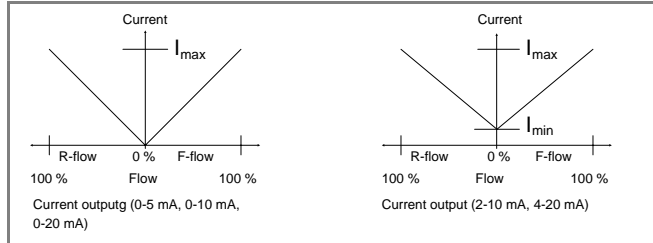
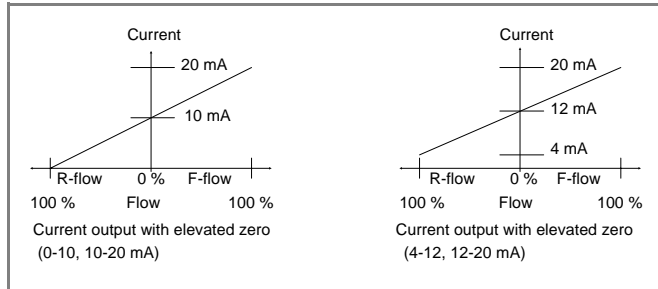

**9.3.16.2 Scaled Pulse Output**

Maximum scaled pulse output frequency is 5 kHz. The pulse multiplication factor may be set between 0.001 and 1000. The pulse width is adjustable from 0.064 ms to 2000 ms.

Optocoupler **Terminals V8, V9,**

$0\text{ V} \leq U_{CEL} \leq 2\text{ V}$ ,  $16\text{ V} \leq U_{CEH} \leq 30\text{ V}$

$0\text{ mA} \leq I_{CEH} \leq 0,2\text{ mA}$ ,  $2\text{ mA} \leq I_{CEL} \leq 250\text{ mA}$

**9.3.16.3 Contact Output (option)**

The following functions are selectable via the software:

- **System Supervision** opened or closed at alarm <sup>1)</sup>
- **Empty Pipe** opened or closed at alarm
- **Forward/Reverse Flow** - closed for forward flow
- **Limit Alarm** opened or closed at alarm
- **Optocoupler, terminals G2 & P7**  
 $16\text{V} < U_{CEH} < 30\text{V}$ ,  $0\text{V} < U_{CEL} < 2\text{V}$   
 $0\text{mA} < I_{CEH} < 0.2\text{mA}$ ,  $2\text{mA} < I_{CEL} < 15\text{mA}$

<sup>1)</sup> Contact functions (normally closed, normally open) are software selectable.

**9.3.16.4 Contact Input (option)**

The following functions are software selectable:

- **External Output Cut-off** - All output signals are turned off if pipe is empty.
- **External Totalizer Reset** - The internal Totalizer value can be reset via an external contact closure.
- **Optocoupler, Terminals G2 & X1**  
 $16\text{V} < U < 30\text{V}$ ,  $R_i = 2\text{k}\Omega$

**9.3.16.5 Empty Pipe Signalling (option)**

By using the optional "automatic empty pipe cut-off", an "Empty Pipe" condition is detected and signalled. Contact output opens for an alarm condition.

During this condition, the current output is forced to 0% or 130% of the limiting current value and the Totalizer will stop incrementing.

Conductivity  $\geq 20\ \mu\text{S}/\text{cm}$ , size  $\geq 15\text{mm}$

**9.3.16.6 HART-Protocol (option)**

**Part Number CD699B143U01, Rev. X.17** is the **HART<sup>®</sup> PROTOCOL** firmware.

The optional HART<sup>®</sup> protocol system, when supplied, permits simultaneous 4-20 mA and digital signal transmission on the same 2-wire cable. With this protocol, process parameters such as instantaneous flow rate and cumulative total flow, or operating conditions such as alarm values, can be monitored or altered by an external "smart " device, e.g., a host computer. This interface allows the Converter's data base to be uploaded into the host computer. Operating parameters which would only be changeable at the Converter can be scanned and remotely reconfigured.

Software and hardware are optionally available to implement a HART<sup>®</sup> Protocol information exchange between the converter and a HART<sup>®</sup> Protocol master device. This data link permits continuous monitoring of process variable and totalized flows and provides for configuration of the following:

- Values and units for range
- Pulse factor and units for totalizers as well as reset capability
- Damping, noise reduction, low flow cutoff value
- Empty pipe detector setup
- Alarm fail safe condition
- Converter tag name and record information
- Calibration of the analog (4 - 20 mA) output

The following parameters may be displayed but not configured:

- Meter size and calibration factor
- Instrument model type and manufacturer (ABB Instrumentation)
- Totalizer overflow values

Refer to the HART<sup>®</sup> Model 275 Communicator Instruction Bulletin for detailed information regarding application of HART<sup>®</sup> Protocol.

**Transmission mode**

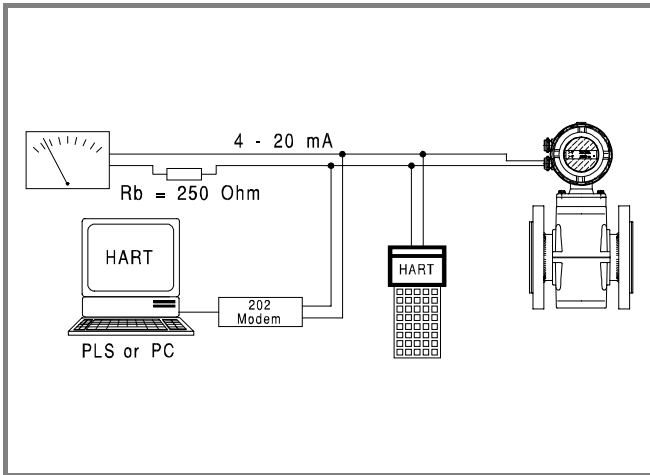

**FIGURE 9-4. HART PROTOCOL COMMUNICATION**

When implementing the HART<sup>®</sup> protocol, the control computer is the master and the field transmitter the slave. In addition to this primary master a second master (such as the Model 275 Hand-Held Communicator) can become active.

The digital communication occurs through use of an alternating voltage superimposed on the current output which does not affect any other instruments connected to this current output. This option is only available on the "+/-" output terminals with a 4-20 mA output current. FSK current modulation is superimposed on the 4–20 mA current output at 1200 baud in accordance with the Bell 202 standard. Maximum signal amplitude is 1.2 mA p-p.

**NOTE**

The "SERVICE" sub-menu developed for the 275 Communicator contains features intended to be used only by Bailey-Fischer & Porter service personnel. Many of the functions shown are intentionally undocumented in the Instruction Bulletin. Modifying these functions without thoroughly understanding them can cause the flow measuring system to become inoperative or inaccurate.

It is also recommended that the "Meter Size" and "USL" (upper sensor limit/meter capacity) parameters not be changed using the Communicator. If changed, errors could develop later, especially after a power interruption.

When using the HART firmware, some flow and totalizer units are no longer available. Refer to Tables 9-8 & 9-9 for units available with the HART firmware.

**9.3.16.6.1 HART Specifications**

**Load, Current Output**

Min.: >250 Ω, max. < 600 Ω

**Cable**

AWG 24 twisted

**Maximum Cable Length**

1500 meters (approx. 4900 feet)

**Baud Rate**

1200 Baud

Logical 1: 1200 Hz

Logical 0: 2200 Hz

**9.3.16.6.2 Menu Selection**

A submenu entitled **Submenu Data Link** appears between the Standard firmware's **Current Output** and **Function Test** submenus. Its contents are as follows:

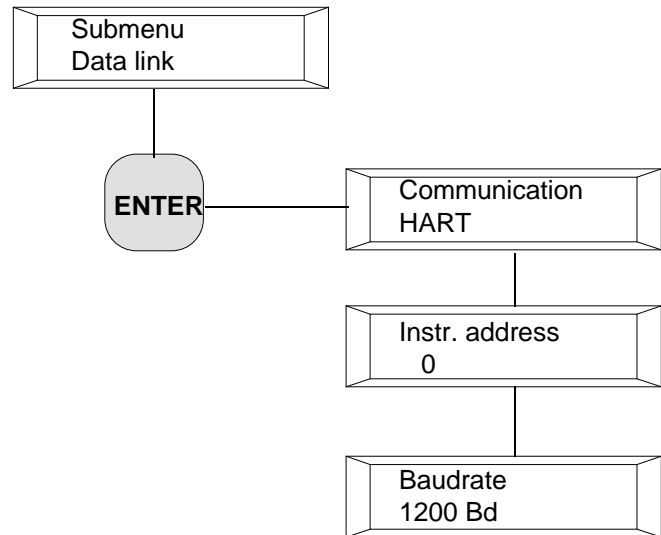

Special HART<sup>®</sup> features are now available which were previously not available, these include:

- A function test for the modem which superimposes either 2200 Hz or 1200 Hz signals on the analog output
- A function test that displays the HART<sup>®</sup> command received from a master device

### **9.3.16.6.3 Model 275 Menu Sequence**

The Model 275 Hand-Held HART Communicator menu sequence is shown on the following pages for reference.

ONLINE

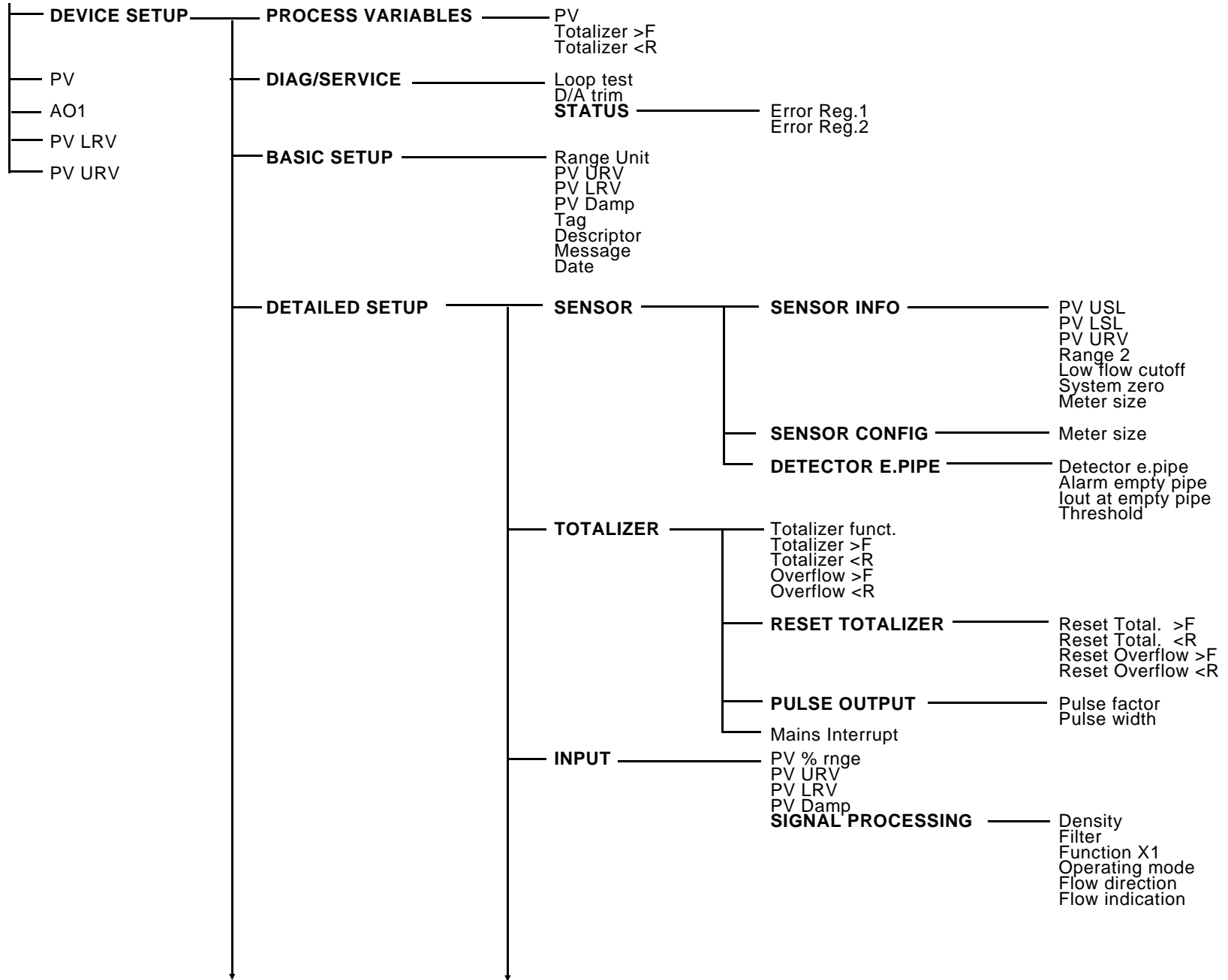

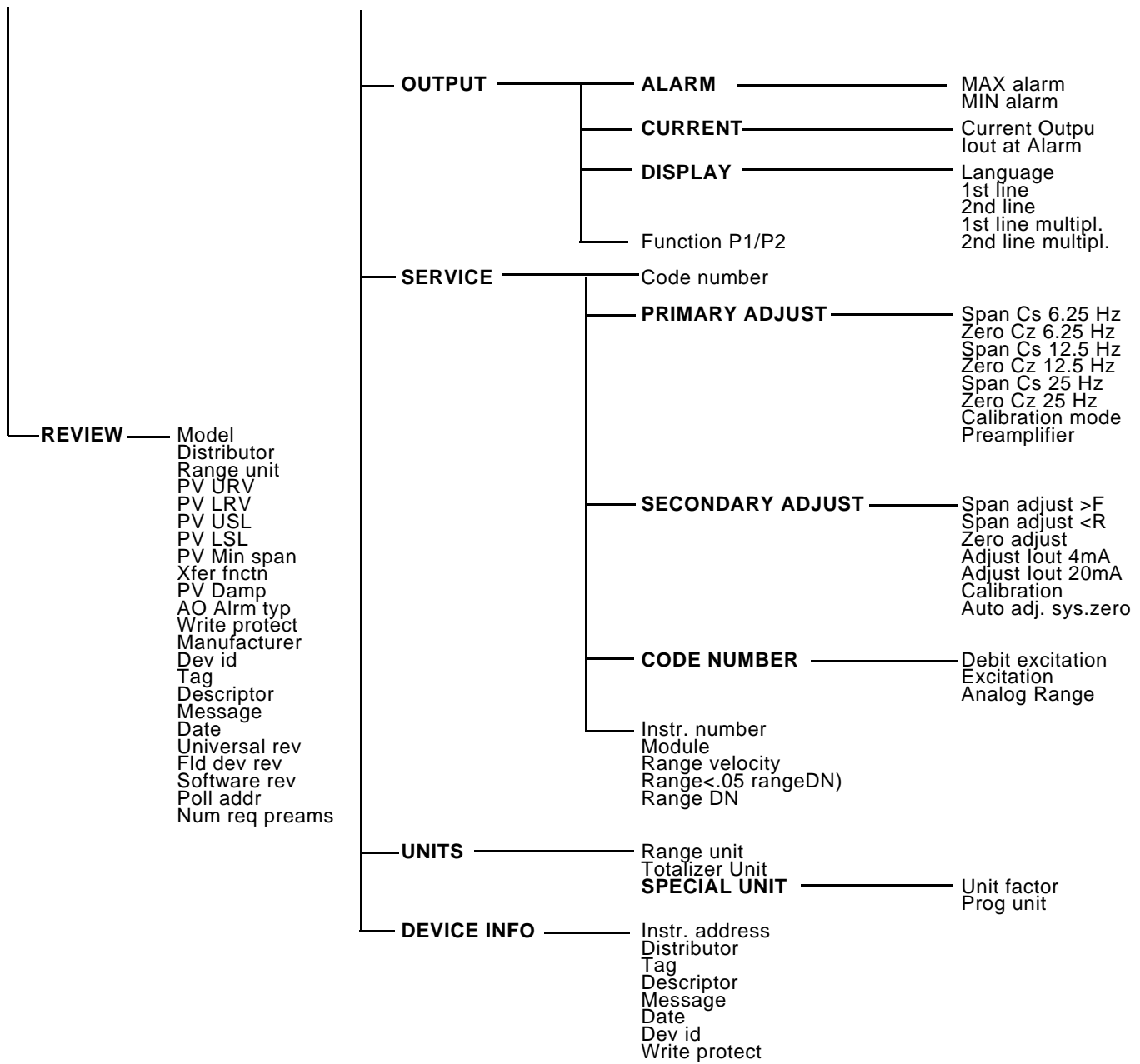



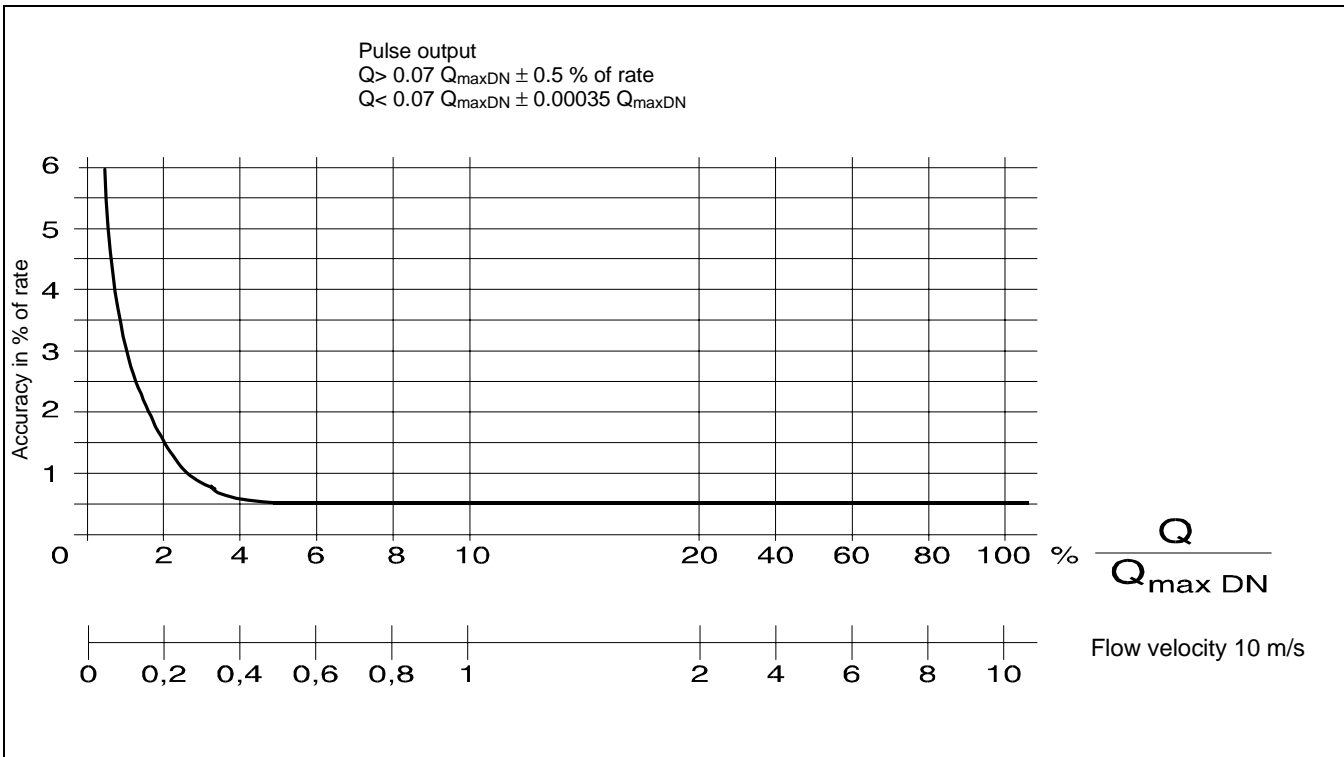

FIGURE 9-5. ACCURACY UNDER REFERENCE CONDITIONS

**9.3.17 Reference Conditions in Accordance with EN 29104**

Refer to FIGURE 9-5.

**9.3.17.1 Fluid Temperature**

$20\text{ }^{\circ}\text{C} \pm 2\text{ }^{\circ}\text{C}$

**9.3.17.2 Ambient Temperature**

$20\text{ }^{\circ}\text{C} \pm 2\text{ }^{\circ}\text{C}$

**9.3.17.3 Power Supply**

Rated voltage according to nameplate  $\pm 1\%$

**9.3.17.4 Installation Conditions of Straight Pipe Section**

Upstream of primary  $> 10 \times \text{DN}$

Downstream of primary  $> 5 \times \text{DN}$

where DN = nominal meter size

**9.3.17.5 Warm-Up Time**

30 minutes

**9.3.17.6 Analog Output Influence**

Same as pulse output but with additional  $\pm 0.1\%$  of span.



## DOCUMENTATION QUESTIONNAIRE

Your answers to the questions below and other comments assist us in publishing better documentation. If an answer requires explanation please use the space provided. All comments and suggestions become the property of ABB Automation Inc.

1. Title of Document? IB 10DX4311A, Sizes 6" to 12" PN24760B

2. Does this document meet your needs? \_\_\_\_\_

3. Is the information:

Easily understandable? \_\_\_\_\_

\_\_\_\_\_

\_\_\_\_\_

Properly organized? \_\_\_\_\_

\_\_\_\_\_

Complete? \_\_\_\_\_

\_\_\_\_\_

\_\_\_\_\_

Sufficiently illustrated? \_\_\_\_\_

\_\_\_\_\_

\_\_\_\_\_

### OTHER COMMENTS

(Please include page and/or figure number.)

\_\_\_\_\_

\_\_\_\_\_

\_\_\_\_\_

\_\_\_\_\_

\_\_\_\_\_

Name \_\_\_\_\_

Address \_\_\_\_\_

\_\_\_\_\_

\_\_\_\_\_

No postage necessary  
if mailed in the U.S.A.

If ABB employee, please include  
department number.

CUT ALONG LINE, FOLD, STAPLE



FOLD 1



NO POSTAGE  
NECESSARY  
IF MAILED  
IN THE  
UNITED STATES

**BUSINESS REPLY MAIL**

FIRST CLASS PERMIT NO. 86 WARMINSTER, PA

POSTAGE WILL BE PAID BY ADDRESSEE:

**ABB INSTRUMENTATION  
DEPARTMENT 261 / A2  
125 EAST COUNTY LINE ROAD  
WARMINSTER, PA 18974**

Attention: Technical Publications

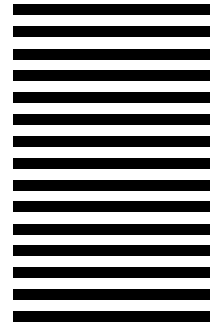

FOLD 2

STAPLE  
HERE



Copyright © 1999 by ABB Automation Inc., as an Unpublished Work  
® Registered Trademark of ABB Automation Inc.  
™ Trademark of ABB Automation Inc.

---

**ABB Automation Inc.**  
Instrumentation Division  
125 East County Line Road  
Warminster, PA 18974 USA  
Tel. 215-674-6000  
FAX: 215-674-7183

**ABB Instrumentation Ltd**  
Howard Road, St. Neots  
Cams. England, PE19 3EU  
Tel. 44 (0) 1480-475321  
FAX: 44 (0) 1480-217948

**ABB Kent-Taylor spa**  
Via Statale 113  
22016 Lenno (Como) Italia  
Tel. 39 (0) 344 58111  
FAX: 39 (0) 344 56278