LOW VOLTAGE AC DRIVES

Maximize the productivity of your rubber process

with ABB drives, motors and PLCs



- In addition to drives, we offer PLCs, HMIs and various motor solutions, making it easy to get all your machine needs from one supplier.

Productivity. Reliability. Final product quality.

Everything counts for rubber tire process layout and machinery.

Whatever kind of rubber you may be molding for tires or rubber products, you need the right automation system that powers the most efficient drives and motors to maximize reliability and end-product quality. ABB drives, motors, PLCs and application expertise helps ensure that you get the best energy efficiency in your rubber process, with a high return on investment and reduced CO₂ emissions.

We supply a broad line-up of drives and motors that provide superior productivity and best-in-class energy efficiency, while also enabling fast machine setup. They can deliver high torque all the way down to zero speed. They can also handle high and longtime overloads when required by process conditions.

Our drives and motors are designed to work well in harsh and aggressive environments such as rubber plants that have corrosive dust, gases and additives.

We can support you during the automation and drive system design process to ensure you get the best solution. Our all-compatible drive offering lets you learn it once and use it everywhere. And regarding service, you can have the lowest possible spare parts inventory.

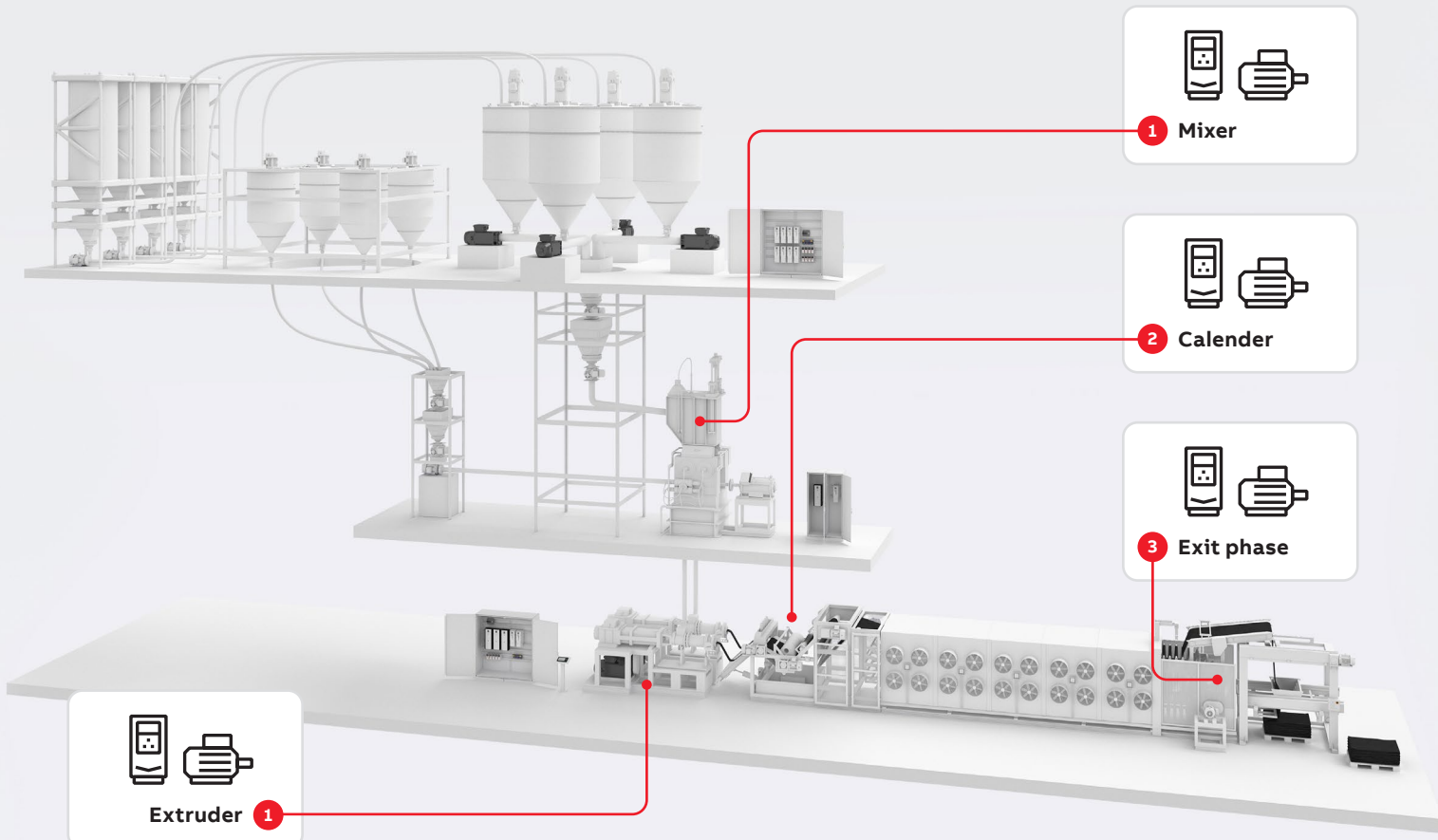



Reliable starting

To overcome the friction of the rubber material, especially when in a cold state, high torque from zero speed is needed during startup. SynRM motors, both air- and water-cooled types, can deliver full torque from zero speed thanks to our drives' DTC (direct torque control) technology and best-in-class vector control.



Superior motor control, for best rubber quality

SynRM technology motors, with encoderless open loop control, provide highly accurate speed and torque control. This ensures constant speeds can always be maintained, even under fast changing load torque requirements.



Non-stop operation

You can depend on ABB drives and motors to keep your mixers, extruders, calenders and all other tire building machinery running day after day. SynRM motors run with lower bearing and winding temperatures, which further increases reliability and gives longer maintenance interval times.



High efficiency

The combination of SynRM technology with variable speed drive control offers the best package efficiency across any speed range. Compared to a conventional AC motor and drive, you could achieve an energy consumption reduction of up to 2–4 percent. As a result, the payback time for the SynRM solution paired with ABB drives could be less than a year, while helping meet decarbonization targets.

Rubber mixing compounding line – open mill

Advantages that our drives and motors bring to your rubber process:

1 Mixer and extruder zone

- Precise speed and torque
- High starting torque
- Drool/purge finishing mode
- Accurate current to torque ratio
- Load sharing for multi-motor applications

2 Calender conveyor

- Draw/pull ratio
- Torque limit
- Speed trim
- Load cell trim
- Load cell (line shaft)

3 Exit phase

- Surface/center winding
- Stable tension control for desired roll density
- Superior speed/torque coordination
- First class roll quality to eliminate wrinkles, starring and curls
- Position control for length measurement
- Product evacuation and stacking

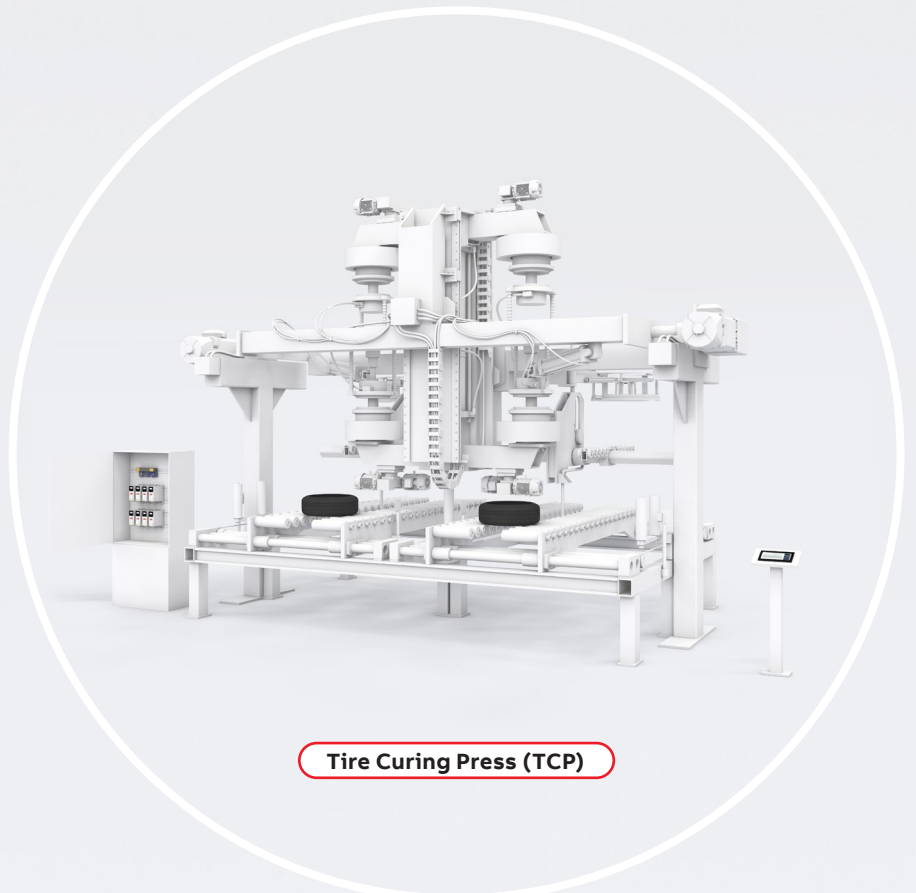

Tire Curing Press (TCP)

ABB drives, motors and PLCs for rubber process

Cloud connection via OPC UA

Every motor, drive and PLC in the rubber process can be securely connected to cloud-based services for easy access to component-level data. This helps detect any component failures fast to minimize maintenance time. All this maximizes your rubber line productivity and flexibility.

Rubber process

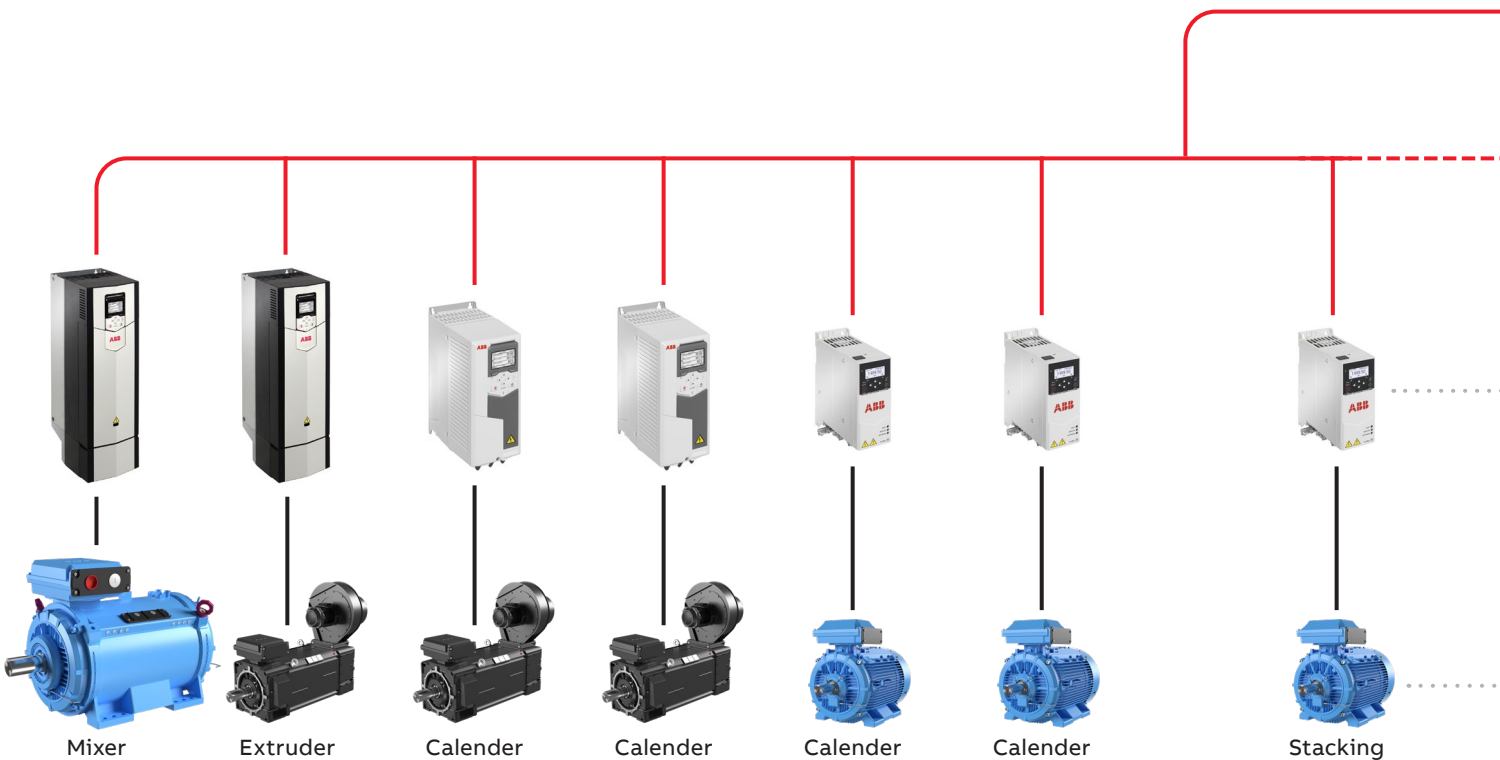
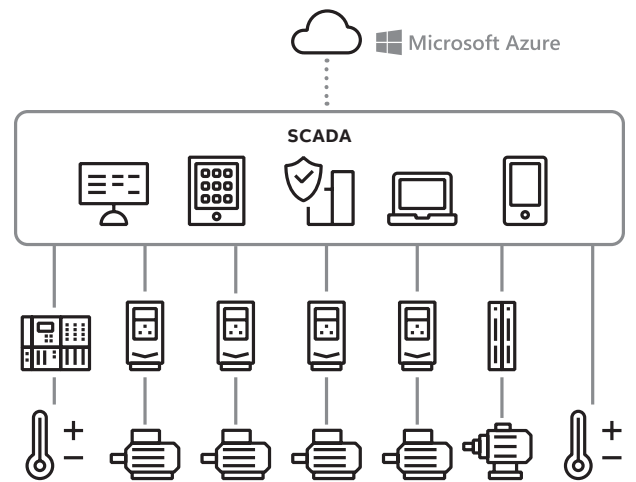

Connecting the system to cloud-based services

All the ABB motors and drives included in the rubber line can be securely connected to ABB Ability™ cloud services according to cybersecurity standards. The connection can be established from our AC500 range of PLCs, or by using third-party PLCs for the gateway to the cloud. ABB's all-compatible drives support all common fieldbus communications.



Automation Builder

Automation Builders is the integrated software suite for machine builders and system integrators requiring state-of-the-art productive machine and system automation. It combines the tools required for configuring, programming, debugging and maintaining automation projects from one common intuitive interface. Automation Builder connects the engineering tools for PLC, safety, control panels, drives and motion control.



PLC library for autotuning temperature control

The extruder's temperature regulation library can be programmed in our AC500 series PLCs or created with traditional solid-state relays.

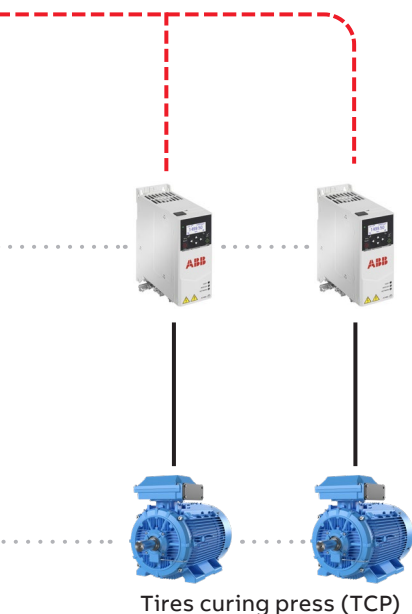

Tires curing press (TCP)

- Trusted network
- - - - - Untrusted network
- Connection between devices

The motors and drives shown in this diagram should be considered product samples for each application. Alternatives can be selected on a case-by-case basis, based on the rubber line's requirements.

From the natural rubber to the mixer process

Tree rubber, the oldest natural rubber in the world.



It is important to realize that tires play a major role in road safety for drivers and passengers. The tire is the interface between the road and the vehicle, and therefore needs to be both strong and flexible, able to provide the right grip to assure safety and performance at all times.

Tire building lines are composed by different steps

Each tire company has its own manufacturing process. Here we will present some typical reference examples which may be close to your actual processes. Please see these as examples.

Some typical tire making processes include:

1. Tire pre-forming
2. Pre-formed tire ready for curing
3. Used tire to be reconditioned to made it as good as new
4. Tire handling before transfer to press vulcanization phase
5. Tires in stock for sales

— **Horizontal mixer**, optimal for small to medium batches. Best for rubber products as boots, gloves, shoes, gaskets, pulley belts, tapes, dampers, fillers and more.

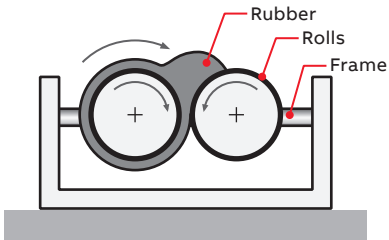

— **Vertical mixer**, the most common process for tire applications, is optimized for large batches. It can be driven with a standard gearbox or with a T gearbox with two inputs and one output. Two inputs means two motors paired with two drives, master/follower, controlled by 50/50 load sharing. You can still run at 50% capacity if one motor/drive set fails. It also optimizes smaller spare parts and sharing them with other Facilities.

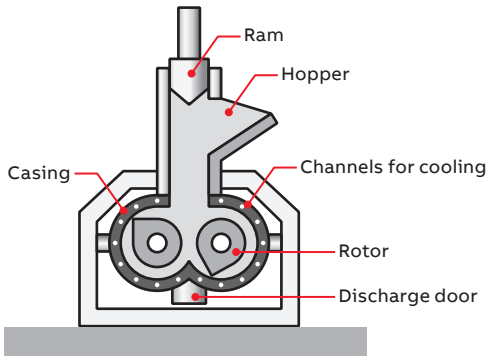

— An example of Torque vs. Time characteristics, based on the rotor's state at the starting mixer phase.

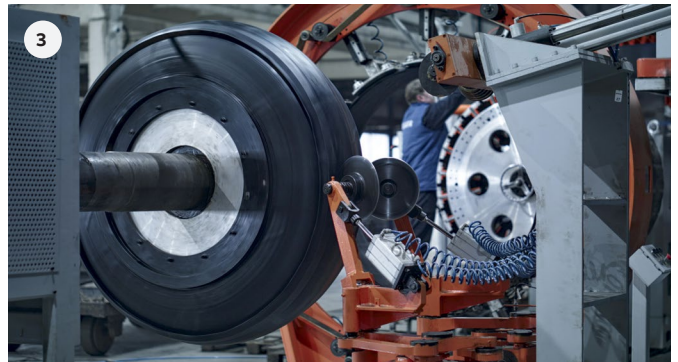
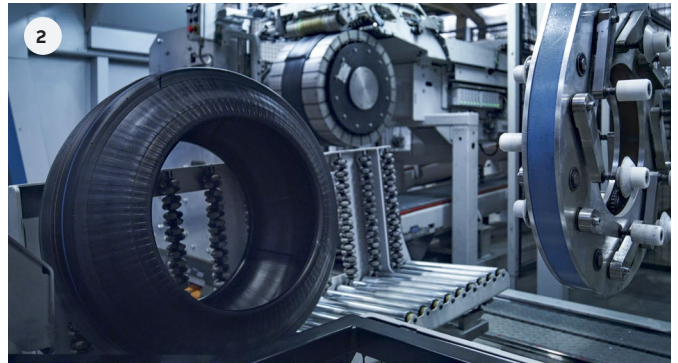
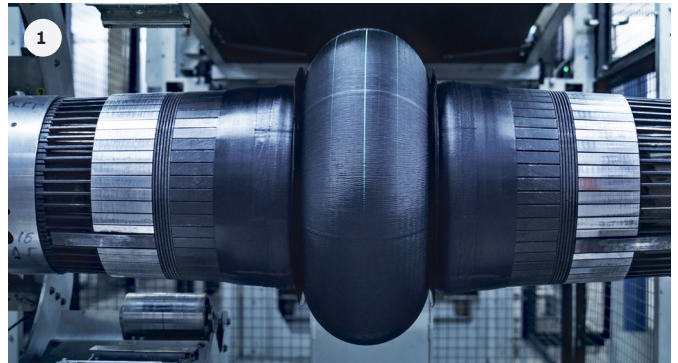
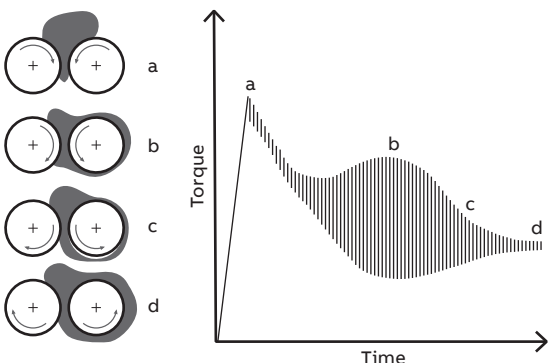

Rubber segment machinery

Tire process by steps

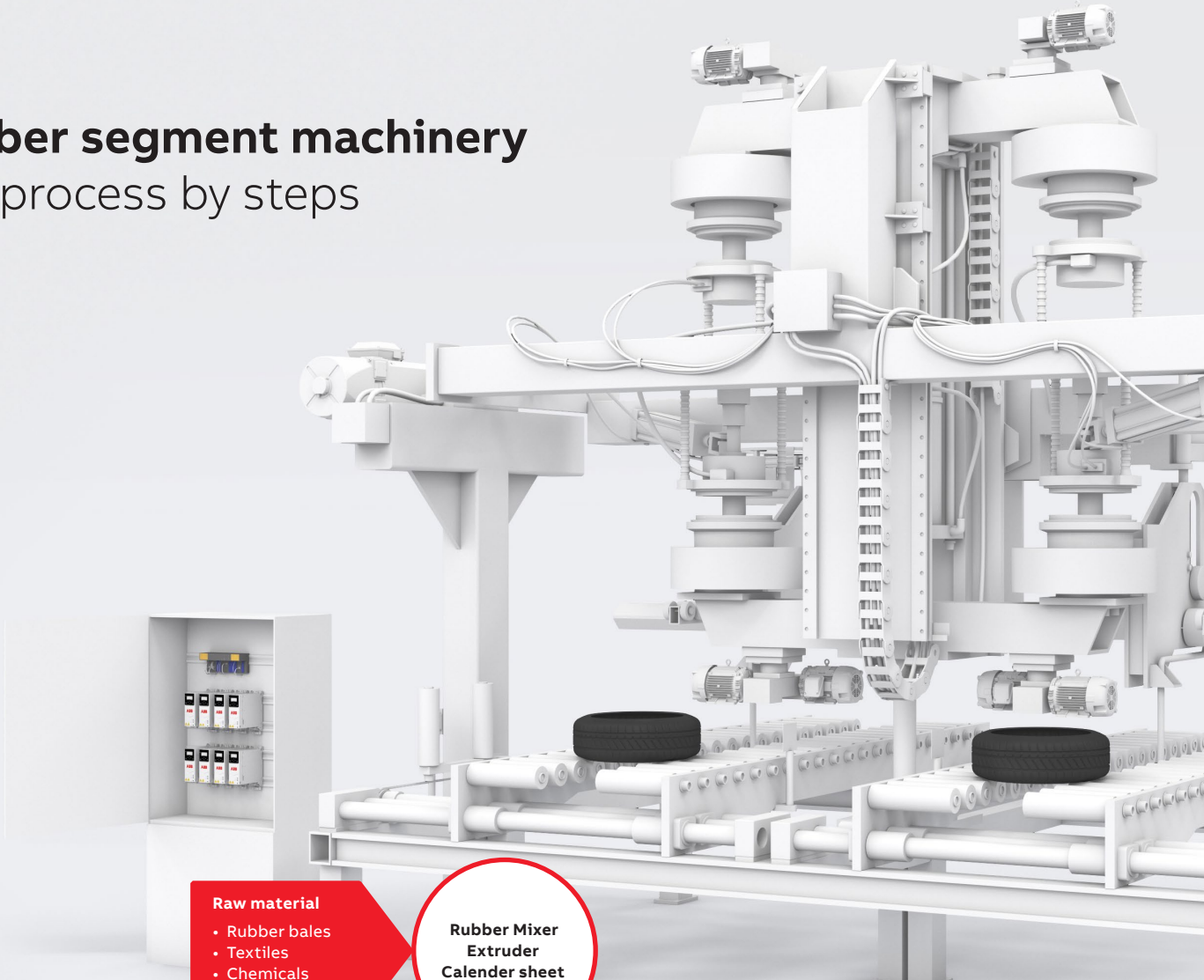



The tire process is a complex and demanding automation environment

Tire companies need to be experts in many different disciplines:

1. Mechanical
2. Chemical (additives, synthetic rubber)
3. Thermodynamic
4. Electrical and automation
5. Data collection to address high-volume mass data decisions to optimize supply chain and process based on demand from field
6. Environment, including energy efficiency and decarbonization
7. Recycling

And, of course, the recent increase in electric vehicles creates both new challenges and/or opportunities. As the engine noise has been reduced with the introduction of electric motors, tire noise has become more evident. So noise dampers are now being introduced, which increases the demand for better process automation. ABB is ready to meet all these challenges with state-of-the-art automation and robotics.



Energy efficiency

The demand for more environmentally friendly industrial processes and lower electricity consumption and bills is increasing every day.

These requirements have highlighted the need for:

- The most energy-efficient process operations, especially in paired drive/motor systems
- Faster payback on investments, both for new installations and for renovation from DC to AC
- Decarbonization, meaning a lower CO₂ process footprint

Our ultra-low harmonic drives ULHD guarantee:

- Power factor 1 at all load conditions and power factor compensation option
- Just active current delivered only, $f \approx$ or colder cables and less trafo iron losses, with $V_1 = V_2$ as full voltage at motor terminals, assuring higher T_{max} .

Selecting the right components

to maximize your rubber process productivity



ABB all-compatible drives for rubber line applications

- Our range of all-compatible drives shares the same user experience with similar software
- Motor control:
 - ACS880 drives with direct torque control (DTC) enable full motor torque across the speed range down to zero – no need for encoders or other feedback devices
 - ACS580 drives with the three-phase output current measurement ensure the best-in-class open loop motor control
 - ACS580 and ACS380 drives include scalar and vector control modes
- Wide range of fieldbus adapters enables connectivity with all major automation networks
- A wide range of drive control panels, from an easy-to-use Basic panel to the Connectivity panel that offers plug-and-play installation with secure and reliable wireless connection to the ABB Ability™ Digital Powertrain, the cloud-based condition monitoring portal for ABB drives
- Commission and troubleshoot drives remotely using smartphone or other mobile device with the Drivetune mobile app or Drive Composer PC tool for more comprehensive commissioning and maintenance Safety:
 - SIL 3 integrated safety, including safe torque off (STO) as standard
 - Optional plug-in module for ACS880 drives provides additional safety features
- Compact design for easy installation, commissioning and maintenance.



AC500 PLCs

Our AC500 range of PLCs allows you to develop even complex custom rubber line solutions with multiple inputs and outputs.



AC500-S safety PLCs

The AC500-S safety PLC offers a flexible platform for building rubber line safety. In rubber lines with several ABB drives, the AC500-S safety PLC can control the overall safety system, activating the drive-based safety functions over PROFINET/PROFIsafe.



ABB drives and motors are even better together

- Accurate motor and speed control, while maintaining superior safety and reliability. No need to further test for certification of motor drive combination
- One vendor standing behind its motor and drive package
- Optimized performance. No need to oversize. Designed to eliminate overheating concerns
- ABB software tools make selecting product combinations easy.

High dynamic performance motors

- Optimized for machine building
- Compact size with high power density
- Robust design for harsh environments
- Ideal for high-torque applications such as extruders
- Motors can be customized with a wide variety of options such as encoders, brakes and monitoring sensors
- Available in a power range from 2.2 to 2,000 kW, IEC frame sizes from 80 to 400 mm.

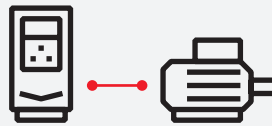
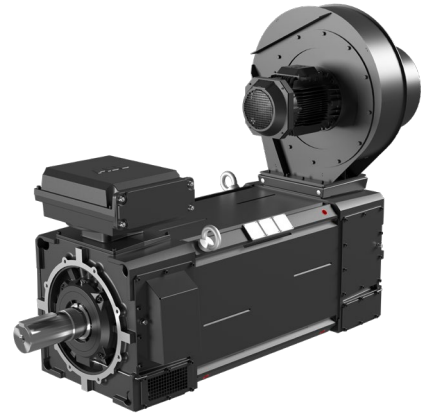
**Synchronous reluctance motors (SynRM)**

- Very high efficiency – up to IE5 – reduces energy consumption and emissions
- Lower winding and bearing temperatures mean improved reliability and longer lifetimes
- Better controllability enables higher-quality extruding through accurate speed and torque control
- Quiet operation reduces noise in the plant for a better working environment
- Available in a power range from 5.5 to 350 kW, IEC frame sizes from 132 to 315 mm air- and water-cooled.

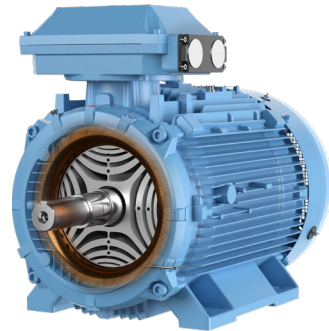
**Water-cooled motors**

- Completely noise-free solution for a location where cooling water is readily available
- Cooling efficiency is maintained throughout the speed range
- Compact size with high power density
- Available in a power range from 90 to 2,000 kW, IEC frame sizes from 280 to 500 mm.

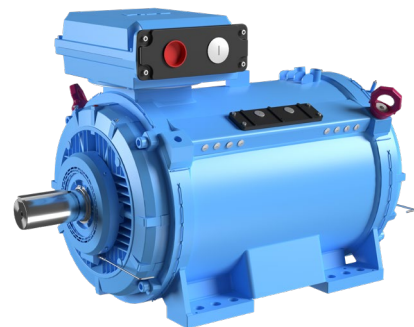
**Process performance motors**

- High efficiency: IE class up to IE4
- Designed for durability in the most demanding environments and applications
- Can be individually designed to the exact demands of the application
- Available in a power range from 0.12 to 1,300 kW, IEC frame sizes from 71 to 500 mm with cast-iron body and IEC frame sizes from 56 to 250 mm with aluminum body.





—
For more information, please contact
your local ABB representative or visit

new.abb.com/drives/segments/plastics-and-rubber

new.abb.com/drives

new.abb.com/motors-generators

new.abb.com/plc

Additional information

We reserve the right to make technical changes or modify the content of this document without prior notice. With regard to purchase orders, the agreed particulars shall prevail. ABB does not accept any responsibility whatsoever for potential errors or possible lack of information in this document.

We reserve all rights in this document and in the subject matter and illustrations contained therein.

Any reproduction, disclosure to third parties or utilization of its content – in whole or in part – is forbidden without prior written consent of ABB.

© Copyright 2024 ABB. All rights reserved.
Specifications subject to change without notice.