

Plant optimization

Online optimization of hybrid desalination plants

Goetz-D. Wolff, Stefan Lauxtermann, Ramesh Kumar



The rapid growth witnessed in the Middle East has brought with it the need for basic infrastructure like power and water services. Hybrid desalination plants are highly flexible and play a vital role in water and power production. However, increasing fuel prices and the need to conserve fuel resources are making it necessary to produce power and water in the most optimized way possible. The challenge of optimization lies in the large range of operational possibilities, which exist in short- and long term operation planning.

This article describes a new approach to the economical optimization of desalination and power plants based on different ABB online and offline optimization packages. The effectiveness of these packages is described through their successful implementation at the Fujairah Water and Power Plant (FWPP) in the United Arab Emirates.

Desalination plants play an essential role in power and water production in the Middle East to meet the ever increasing and dynamic demands. In particular, the number of hybrid desalination plants being built is on the increase largely due to their flexibility in meeting different levels and combinations of production. However, these plants have a complex system structure; especially considering that at least two different desalination process types are used in one hybrid desalination plant. Nevertheless this structure is a hotbed of optimization possibilities.

One such hybrid desalination plant is located 20 km north of the city of Fujairah in the Gulf of Oman. Stringent cost pressure as a result of privatisation meant Fujairah's operators were looking for optimization initiatives to reduce production costs. In 2005 the Fujairah Water and Power Plant (FWPP) installed different ABB optimization packages (from its OPTIMAX® applications family)¹⁾. This performance monitoring and optimization system is the subject of the following paragraphs.

The Fujairah water and power plant

For power generation the plant consists of four General Electric 106 MW PG9171E gas turbines (GTs) with associated heat Recovery steam generators (HRSGs) and two Siemens NG90/90 119 MW steam turbines (STs) **1**. Water production is realized with five multi-stage flash (MSF) distillers, each with a capacity of 12.5 million

Footnote

¹⁾ OPTIMAX® is described in greater detail on page 44 of this issue of ABB Review.

Energy efficient grids

gallons per day (MIGD), and one two-stage reverse osmosis (RO) Plant with 37.5 MIGD capacity. In total the plant has a gross power capacity of about 660 MW and water production in the region of 100 MIGD at 46°C ambient temperature. The HRSGs feed high-pressure steam to a common header. The low-pressure steam used by the MSF units is taken from the steam turbine outlets, or is reduced from high-pressure steam by a reduction station.

Areas of optimization

Fuel costs account for 90 percent of the total spent on fuel, chemicals, spares, and GT, ST, MSF and RO main-

tenance. With the exception of capital costs, fuel is by far the biggest expenditure in power and desalination plants. Therefore the key to increased savings lies in optimizing fuel consumption, and the following tools have been designed with just that purpose in mind:

- *Load Scheduling* which is used for day ahead planning and online optimization
- *Hybrid Optimization* makes online optimization and planning possible
- *Process Optimization* including
 - MSF optimization
 - RO optimization
 - FD-Fan optimization (re-engineering of automation parameters)

Besides optimizing fuel consumption, these tools also allow for maintenance and workflow improvements in the overall work process.

With the exception of capital costs, fuel is by far the biggest expenditure in power and desalination plants, and therefore optimizing fuel consumption is the key to increased savings.

System structure

The modular system structure of the optimization system realized in Fujairah is detailed in 2. Real-time data is collected from a Siemens Teleperm XP via an OPC server, a Siemens Win CC and a GE Mark V system. The data is stored in the long term real-time database, Power Generation Information Manager, or PGIM (former *PlantConnect*) from ABB, which is then used as a common data source for all the optimization tools and other applications. PGIM is also a Plant Information Management System (PIMS) with a Human System Interface (HSI) enabling the user to view graphics, trends and reports. Performance indicators such as GT efficiency are calculated with the integrated software tool known as “Technical Calculation”.

1 Fujairah plant structure

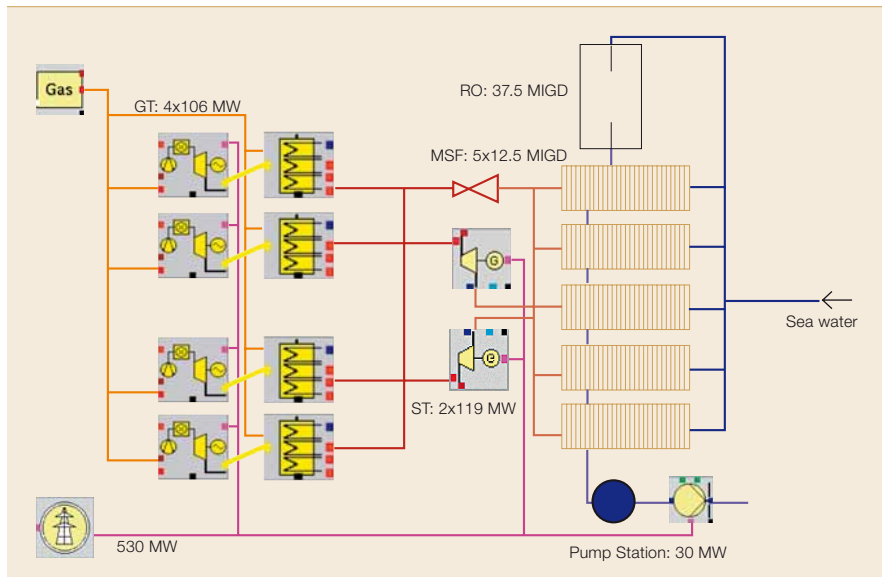

2 System structure

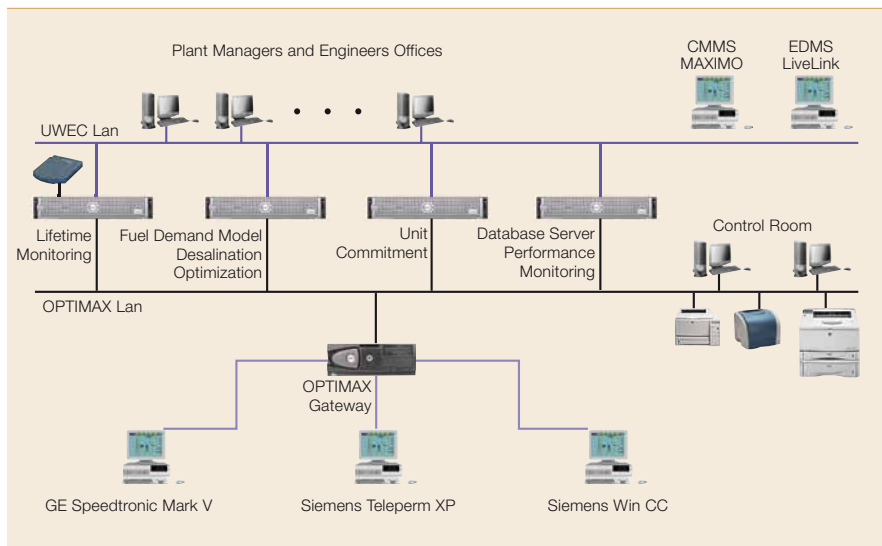

PowerCycle, also from ABB, is a model-based tool which is able to accurately simulate thermodynamic behavior of a plant under varying ambient conditions and different steady-state operating conditions. In Fujairah, the PowerCycle model is used for:

- *Data validation*: It reconciles online measurements to avoid measurement errors
- *MSF optimization*: It gives optimal internal MSF operation setpoints at a given load
- *Fuel Demand Model*: PowerCycle is used to calculate the expected fuel demand according to the plant design, and this is confirmed by performance measurements at plant take over

Other tools include:

- *PowerFit* calculates optimal schedules. This software is mainly used as

a tool for day ahead planning

- *BoilerLife* determines the lifetime exhaustion of the main boiler components

Optimization solution

The optimization solution realized in Fujairah comprises:

- Load scheduling
- Hybrid optimization
- MSF optimization
- Process optimization
- Work process optimization

Load scheduling

The loads, which have to be provided by the water and power plants, vary during the day. This is especially true in the regions where the humidity and the temperature vary, and it is this that affects the load. The example of a daily electrical load curve from the FWPP in 3 shows that the plant operates between 50 and 80 percent of its total net capacity. A 20 percent change, however, is considered normal. A load change of more than 150MW is equivalent to about 1.5 times the maximum capacity of one GT.

The daily water demand is prescribed to the plant. Additional flexibility for plant production exists if the storage capacity of the potable water tanks is taken into account.

The aim of a load scheduling system is to find the optimum combination of plant components to satisfy particular

3 A daily electrical load curve for the Fujairah Water and Power Plant (FWPP)

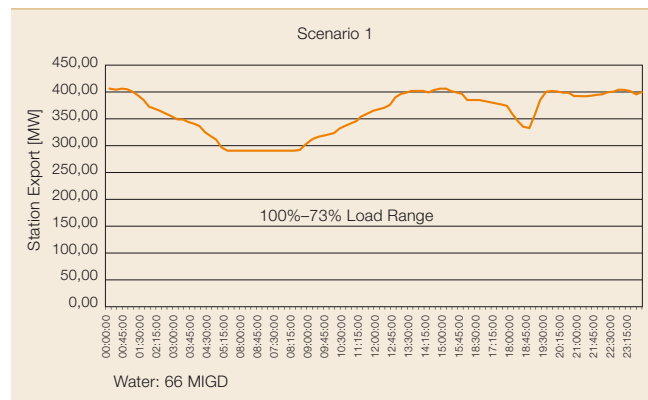

electrical and water export requirements. In other words on the basis of the demands made by load dispatchers, the plant structure, fuel prices, variable maintenance costs, chemical costs, ambient conditions, and operation modes, entire plant and individual unit performance calculations are carried out. The end result is a proposed cost optimal plant operation based on a particular combination of GT, ST, RO and MSF units. In fact, the main benefits of optimization are realized by:

- Finding the best combination between GT and ST production
- Finding the best combination between ST production and bypass steam flow
- Finding the best combination between MSF and RO production
- Utilizing the water storage possibilities

Suitable combinations enable plant optimization to remain valid from one

to several days. The optimization software package comprises four sections:

- A Graphical User Interface (GUI)
- A kernel which coordinates the GUI, optimizer and database.
- An optimizer (CPLEX) whose task is to find the global minimum. It does this by using the Mixed Integer Linear Programming method.
- Oracle database to store all configurations and results.

Schedules for all the major equipment are presented in either table form or as graphics.

In the Fujairah plant it has been proven – using specific test loads and conditions – that an average of 2.7 percent of the fuel costs can be saved by implementing this optimization software. The highest savings are realized in low load operation modes where a potential of 6 percent and more could be achieved.

Hybrid optimization

The Fujairah water plant is of a hybrid nature in that water is produced by MSF and RO units. Potable water has to be produced in a defined quality. However, the water qualities from both processes differ: that produced with the MSF units is almost demineralized and the water produced by the RO units is of a high quality. Therefore the mixed potable water from the two processes has still to be mineral-

4 Hybrid optimization

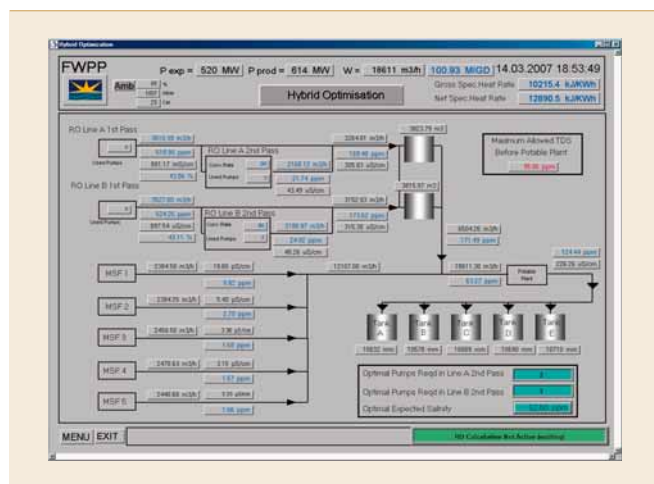

5 A Multi Stage Flash (MSF) cost minimum principle

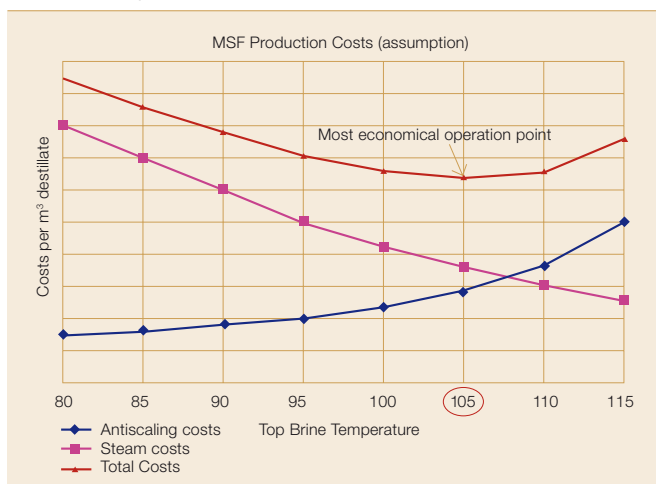

Energy efficient grids

ized by the potable water plant to reach the optimum mineralization criteria stipulated by the health authorities.

The RO plant in Fujairah is a modern plant built by Degremont²⁾. It consists of two lines, each with two passes. The salinity of the first-pass output is in the range of 500 ppm compared to 15 ppm for the second-pass output. Some water bypasses the second-pass and is instead mixed at its output. The water produced by the RO plant before optimization achieves a salinity value in the range of 80–100 ppm.

The aim of optimization is to find the minimum number of second path racks³⁾ needed to meet the guaranteed water quality of the total plant. This in turn reduces:

- Electrical consumption for second path rack pumps by 0.5 MW per pump
- Maintenance costs for second path racks
- Chemical costs in the potable water plant

In addition, reducing the number of running racks in the second pass increases water production by the RO plant since each second-pass rejects approximately 10 percent of the water.

The aim of optimization in an RO plant is to find the minimum number of second path racks needed to meet the guaranteed water quality of the total plant.

The picture/mimic in 4 is used for online hybrid optimization. In this production example two second-pass racks can be taken out of service compared to the standard approach of using one second-pass rack for every two first-pass racks in operation

(1:2 ratio). Additionally an offline tool is also provided for modelling different scenarios. Hybrid optimization in the Fujairah plant saves the equivalent of 0.6 percent of the total fuel costs.

MSF optimization

The main operational costs in an MSF plant are incurred by energy input by steam, chemical additives, and the electrical energy consumed by plant equipment. The job of the MSF optimizer is to minimize the sum of these costs by calculating other set point values that will keep water production constant. A typical cost curve with varying Top Brine Temperature (TBT) values is shown in 5.

The steam costs per m³ distillate decrease with higher TBT because the Performance Ratio (PR) increases if water production is to be kept constant. The chemical costs (eg antiscaling) per m³ distillate increase with higher TBT because of higher scaling at higher temperatures. The optimizer calculates optimized values for the following parameters because at a given load different combinations of these parameters can be used:

- Top brine temperature (TBT)
- Brine recycle flow
- Sea water to reject temperature (winter only)
- Sea water to reject flow
- Make up flow

Additionally, a process simulation package is used which is capable of

modeling MSF units down to the stage level. A model of the MSF line 6 is configured by combining calculated optimized set points for the above mentioned parameters with other components such as a brine heater and pumps. The set points determined by the optimization package are used by the operators for MSF control.

An on- and offline optimization tool is available in the plant. The online tool calculates optimized settings every 10 minutes for a given distillated water production while the offline tool is used for planning purposes.

Using the MSF optimization tool under various operation conditions has saved up to 1.78 percent of the total MSF production costs.

Hybrid optimization in the Fujairah plant saves the equivalent of 0.6 percent of the total fuel costs.

Process optimization

It is essential to monitor the performance of the different plant areas to be able to detect any unusual drop in efficiency 7. The next sections describe the performance calculation in principle, and an example is given where out-of-design parameters were detected.

6 A Multi Stage Flash (MSF) model

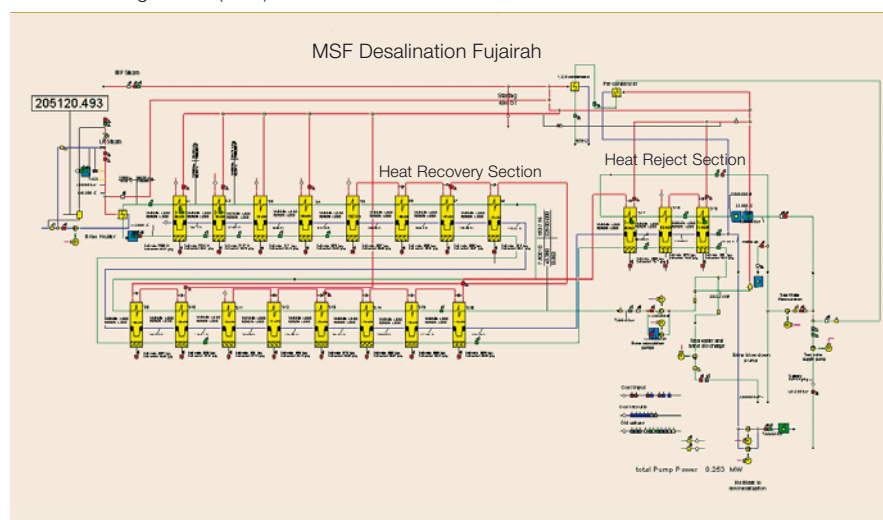

Footnotes

²⁾ <http://www.degremont.ca> (March 2007)

³⁾ A rack is a bundle of membranes for RO desalination (cubicle) which can be switched on and off separately.

7 FWPP process overview

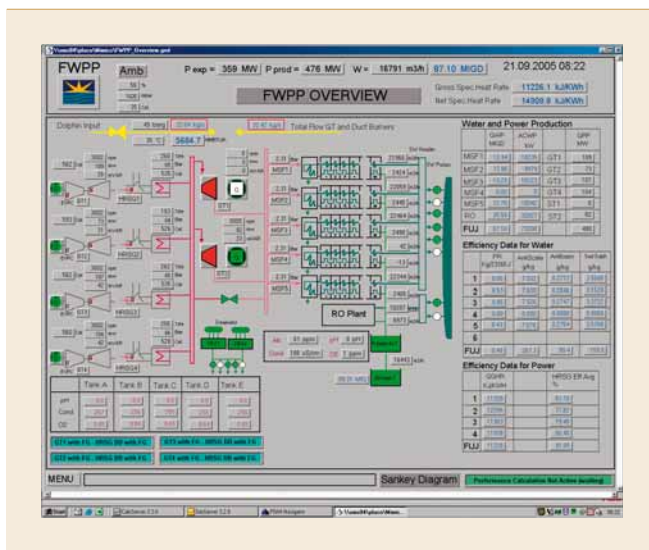

In the FWPP, performance calculations are performed for all major equipment, eg GTs, HRSGs, STs, feed water pumps, the MSF desalination plant, sea water intake pumps, the RO desalination plant and the HP pumps. The screenshot and respective trends **8** are used by operators and engineers to analyze the performance of the entire plant as well as individual areas. Comparisons between actual and expected performance in connection with supervisory identifiers make analyzing simple and effective. However in one particular case, a low HRSG performance was detected when the Performance Monitoring and Optimization system was used. An investigation disclosed that the problem lay with the FD-Fan. To be more precise the FD-Fan is started only when the average flue gas temperature behind the duct burners exceeds a specific control set point. In the FWPP, this value was set at 800°C. However, design criteria stated a value of 840°C was required, and the 40°C difference translated into a 1.7 percent drop in boiler efficiency during FD-Fan operation.

Additionally the fans never stopped once started because the lower set point temperature value of 700°C was deemed too low (the temperature rarely fell below this value). The operation practice was changed after the implementation of the software package, and the result since then has been increased efficiency.

Work process optimization

In addition to process and operation optimization, areas of the work process that can also be optimized and improved include:

- The *automatic creation of logs and reports* which saves working time and avoids manual entry errors
- The *automatic exchange of data with other systems*, for example computerized maintenance management system (CMMS)

In Fujairah more than 100 logs and reports have been automated, resulting in an estimated daily saving of about 18 hours work. Easy-to-use tools to configure different types of reports are developed by ABB using Microsoft Excel software in the system.

Altogether, more than four percent of the total fuel consumption is saved in Fujairah, with additional savings attributed to work process optimization.

Conclusions

The proven installation of a Performance Monitoring and Optimization System in the Fujairah water and power plant sums up the effectiveness of modern optimization techniques in power plants. In fact most of the optimization techniques described can al-

8 Heat balance diagram with calculated heat flows

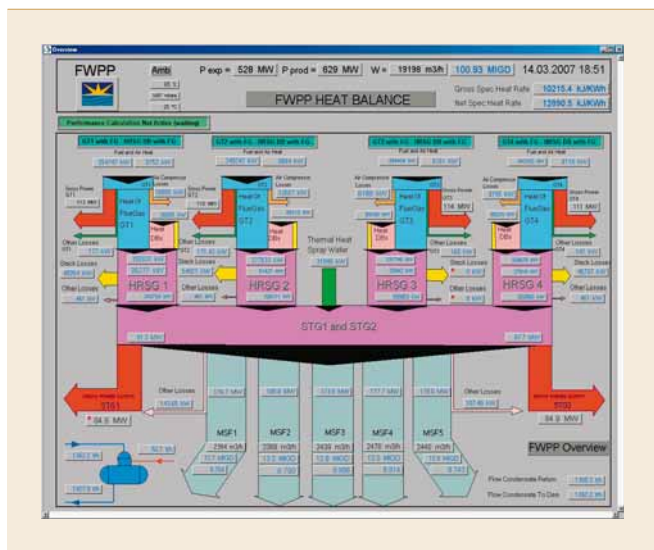

so be used in power and desalination plants with a non-hybrid structure.

Altogether, more than four percent of the total fuel consumption is saved in Fujairah, with additional savings attributed to work process optimization. The benefits realized indicate the potential that exists for other hybrid and non-hybrid plants.

Goetz-D. Wolff

Stefan Lauxtermann

ABB AG, Minden

Germany

goetz.d.wolff@de.abb.com

stefan.lauxtermann@de.abb.com

Ramesh Kumar

ABB AG, Abu Dhabi

UAE

ramesh.kumar@uae.abb.com

Further reading

- [1] Ludwig Heinz, Stummeyer Karen, FICHTNER, Potabilisation – Nachbehandlung von Destillat und Permeat aus Meerwasserentsalzungsanlagen, May 2004
- [2] Glade Heike, Meyer Jan-Heige, Will Stefan, Strategies for optimization of the Reverse Osmosis Plant in Fujairah, June 2005
- [3] Water Quality Regulation of UAE, Revision 2, January 2004
- [4] On technical and market aspects of water desalination, Nils Huesgen, December 2002