

# Installation suggestion FOUNDATION Fieldbus

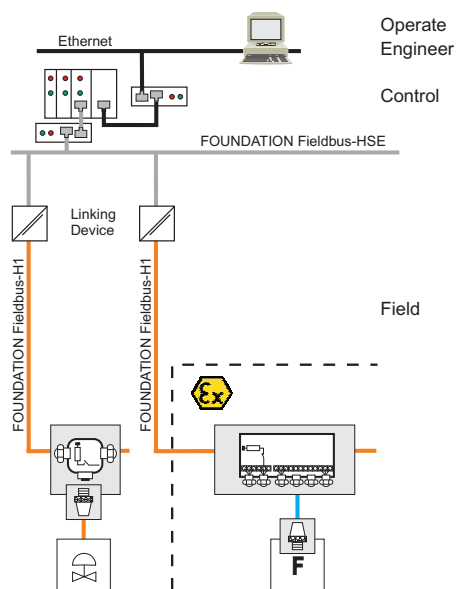

## FOUNDATION Fieldbus-HSE/H1

- LD 800HSE Linking Device

## FOUNDATION Fieldbus-H1

- FieldBarrier in Ex (Haz.) area
- Passive T and 4-way-junction in Non-Ex area

## Shielding and grounding

- FOUNDATION Fieldbus-H1

## FOUNDATION Fieldbus-H1 layout example

- FieldBarrier in Ex (Haz.) area
- Passive 4-way junction in Non-Ex area



# FOUNDATION Fieldbus - Installation suggestion

## FOUNDATION Fieldbus-HSE/H1 - LD 800HSE Linking Device

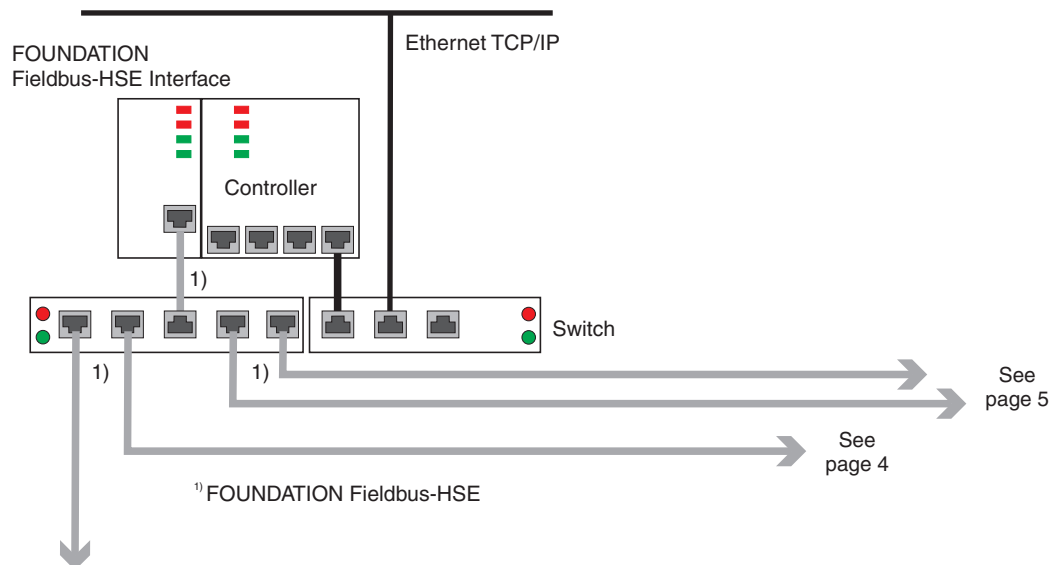

Color coding:

FOUNDATION Fieldbus-H1:

H1+ = orange

H1- = blue

M00560\_EN

### FOUNDATION Fieldbus-HSE/H1 - LD 800HSE (with Power Conditioner)

24 V DC  
≤ 200 mA

16 ... 32 V DC  
≤ 1.02 A

Ex (Haz.) area  
Non-Ex area

See page 6

See page 7/8

M00561\_EN

	Description	Catalog No.	Data sheet
1	<b>LD 800HSE</b> - Linking Device HSE/H1 HSE-Bus 10 and 100 Mbit/s, 4 x H1-Bus fix 31.25 kBit/s, IP 20, rail mounting ♦ Power-PINs: L+ = (+), M = (-) ♦ PINs: <b>FF1 / FF2 / FF3 / FF4</b> : (+) = H1+, (-) = H1-, S = shielding	3BDH000320R02	3BDD011675Rxx01
2	FOUNDATION Fieldbus-H1 cable, orange <b>NFC080-NO</b> - 0.88 mm <sup>2</sup> , 43.6 Ω/km, 65/330/1000 m	63668-9 890 16x	10/63-6.67
3	<b>KLD2-PC-1.1.IEC</b> - Power Conditioner H1-power supply: U <sub>S</sub> = 14.7 ... 30.7 V DC, I <sub>S</sub> ≤ 1 A, incl. switchable bus termination. ♦ Power-PINs: 8 = (+), 9 = (-) ♦ H1-PINs: <b>IN</b> : 6 = H1+, 5 = H1-, 4 = shielding <b>OUT</b> : 3 = H1+, 2 = H1-, 1 = shielding	On request	

**Attention (valid for all pages): For the PIN coding the respective product data sheet is relevant!**

## FOUNDATION Fieldbus-HSE/H1 - LD 800HSE Linking Device (with Motherboard, Simplex)

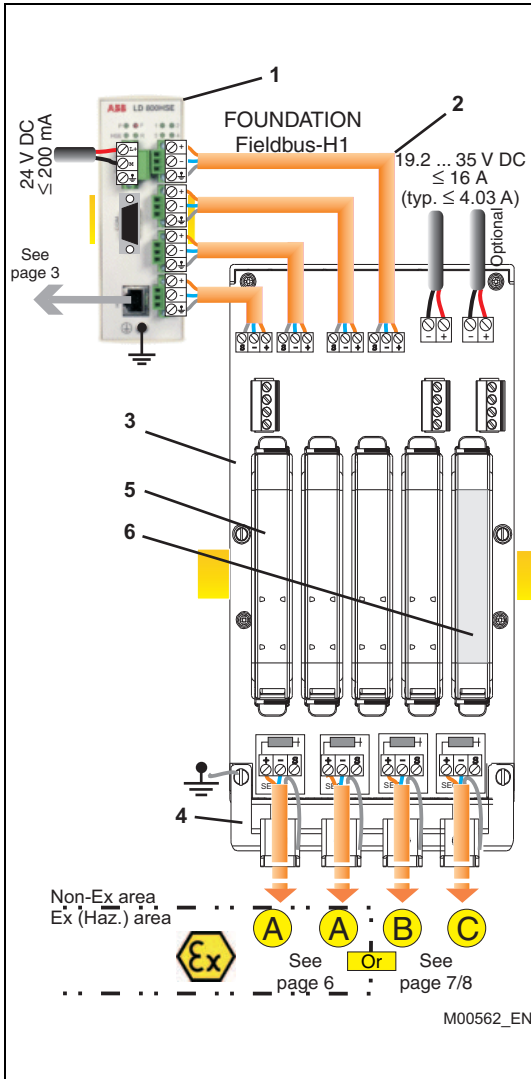

Description	Catalog No.	Data sheet
<b>1 LD 800HSE</b> - Linking Device HSE/H1 HSE-Bus 10 and 100 Mbit/s, 4 x H1-Bus fix 31.25 kBit/s, IP 20, rail mounting ♦ Power-PINs: L+ = (+), M = (-) ♦ PINs: <b>FF1 / FF2 / FF3 / FF4</b> : (+) = H1+, (-) = H1-, S = shielding	3BDH000320R02	3BDD011675Rxx01
<b>2 FOUNDATION Fieldbus-H1 cable, orange</b> <b>NFC080-NO</b> - 0.88 mm <sup>2</sup> , 43.6 Ω/km, 65/330/1000 m	63668-9 890 16x	10/63-6.67
<b>3 MB-FB-4</b> Motherboard, for 4x power supply modules & for 1x diagnostic module, 4x switchable H1 bus terminator, DIN top-hat rail, IP 20, II 3G EEx nAC IIC T4, Zone 2/Class I, Div. 2. ♦ Power PINs: <b>PRI</b> : + = (+), - = GND, <b>SEC</b> (optional): + = (+), - = GND ♦ H1 PINs: <b>IN segment 1/2/3/4</b> : + = H1+, - = H1-, S =shield ♦ H1 PINs: <b>OUT segment 1</b> : + = H1+, - = H1-, ACC-MB-HSK = shield <b>and!</b> motherboard grounding firmly. <b>OUT segment 2/3/4</b> : + = H1+, - = H1-, ACC-MB-HSK = shield	On request	
<b>4 ACC-MB-HSK</b> (optional) Grounding connection set for large-surface connection of the trunk cable shields.	On request	
<b>5 Power supply modules</b> H1 bus fixed at 31.25 kbit/s, IP 20, II 3G EEx nA II T4, Zone 2/Class I, Div. 2. <b>HD2-FBPS-1.500</b> (for "A", "B", or "C") - H1 power feed: U <sub>S</sub> = 28 ... 30 V DC, I <sub>S</sub> ≤ 500 mA, elec. isolation. <b>HD2-FBCL-1.500</b> (for "A", "B", or "C") - H1 power feed: U <sub>S</sub> = 16.7 ... 29.5 V DC, I <sub>S</sub> ≤ 500 mA, no elec. isolation.	On request	
<b>6 Diagnostic modules (optional)</b> For supply & H1 bus, IP 20, Zone 2/Class I, Div. 2. <b>HD2-DM-B</b> (Basic), II 3G EEx nAC IIC T4 - Check power sources, power supply modules, and H1 for overload and short circuit, etc. - Messages only transmitted by means of relay contact. <b>HD2-DM-A</b> (Advanced), II 3G EEx nA IIC T4 - Additional physical layer checks. - DTM Diagnostic Manager (one of three is required) - DTM Basic version - DTM-FC.AD Professional, ≤ 100 segments - DTM-FC.AD.1 Professional, > 100 segments	On request	



### Important! (For Simplex only)

- Max. **31** H1 field devices per power supply module.
- All modules can be combined with all other modules.
- First check that the diagnostic DTMs have been approved for your frame application.

### Color coding:

#### FOUNDATION Fieldbus-H1:

- H1+ = orange
- H1- = blue

# FOUNDATION Fieldbus - Installation suggestion

## FOUNDATION Fieldbus-HSE/H1 - LD 800HSE Linking Device (with Motherboard, Redundant)

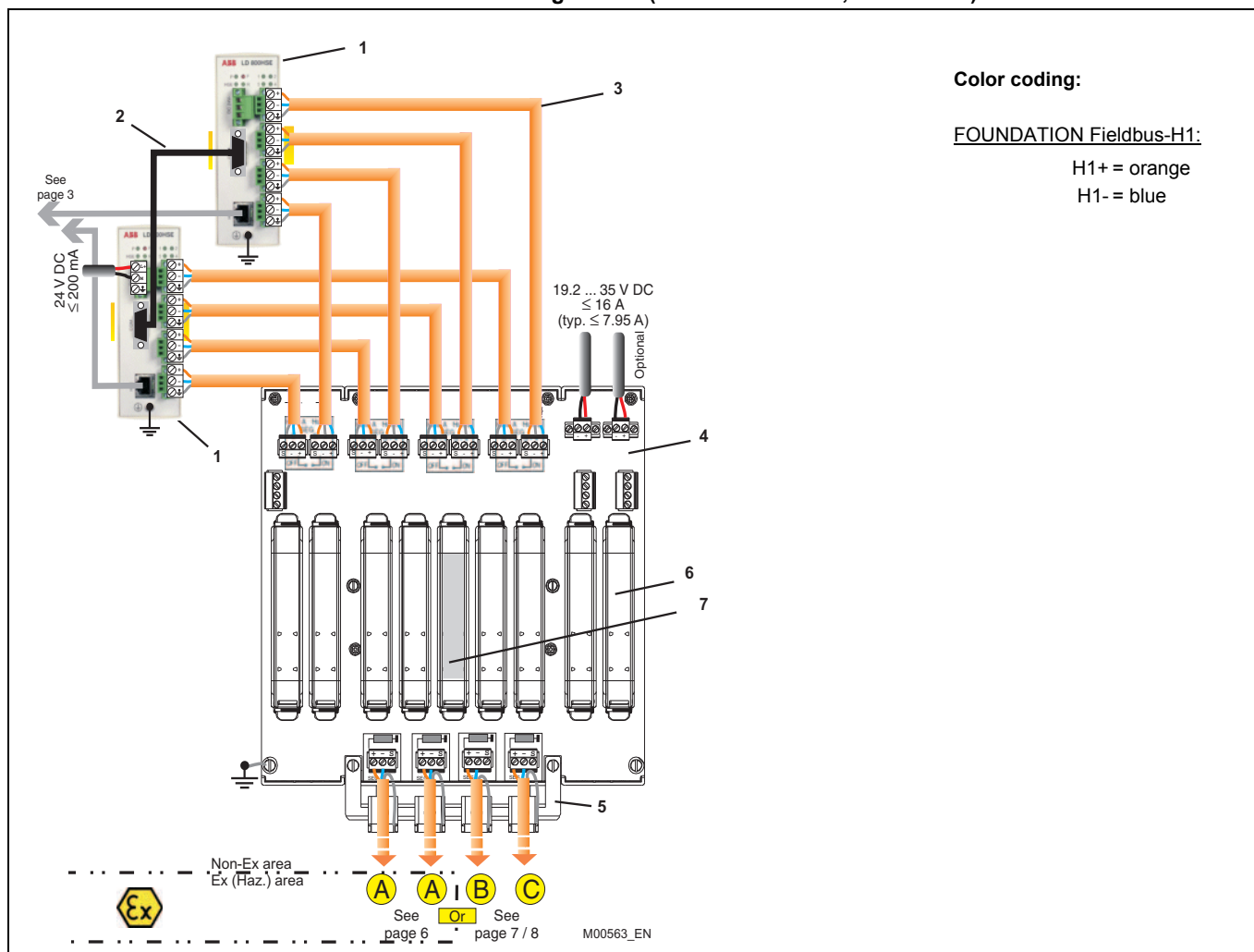

**Color coding:**

**FOUNDATION Fieldbus-H1:**

H1+ = orange

H1- = blue



### Important!

- Max. **30** H1 field devices per power supply module (red.).
- All modules can be combined with all other modules.
- If only one LD 800HSE (host) is being used, the redundancy switch must be switched to the motherboard.
- First check that the diagnostic DTMs have been approved for your frame application.

Description	Catalog No.	Data sheet
<b>1 LD 800HSE</b> - Linking Device HSE/H1 HSE bus with 10 and 100 Mbit/s, 4 x H1 buses fixed at 31.25 kbit/s, IP 20, top-hat rail mounting ♦ Power PINs: L+ = (+), M = (-) ♦ PINs: <b>FF1 / FF2 / FF3 / FF4:</b> (+) = H1+, (-) = H1-, S = shield	3BDH000320R02	3BDD011675Rxx01
<b>2</b> Redundancy Link Cable, 0.50 m	3BDH000281R1	3BDD011675Rxx01
<b>3</b> FOUNDATION Fieldbus-H1 cable, orange <b>NFC080-NO</b> - 0.88 mm <sup>2</sup> , 43.6 Ω/km, 65/330/1000 m	63668-9 890 16x	10/63-6.67
<b>4 MB-FB-4R</b> Motherboard, for 2x4 power supply modules (redundant) & for 1x diagnostic module, 2x4 host connections (redundant), 4x switchable H1 bus terminator, DIN top-hat rail, IP 20, II 3G EEx nAC IIC T4, Zone 2/Class I, Div. 2. ♦ Power PINs: <b>PRI:</b> += (+), -= GND, <b>SEC</b> (optional): += (+), -= GND ♦ H1 PINs: <b>IN A/B segment 1/2/3/4:</b> += H1+, -= H1-, S = shield ♦ H1 PINs: <b>OUT segment 1:</b> += H1+, -= H1-, ACC-MB-HSK = shield <b>and!</b> motherboard grounding firmly. <b>OUT segment 2/3/4:</b> += H1+, -= H1-, ACC-MB-HSK = shield	On request	
<b>5 ACC-MB-HSK</b> (optional)	On request	
<b>6</b> Power supply modules <b>HD2-FBPS-1.500</b> (for "A", "B", or "C") <b>HD2-FBCL-1.500</b> (for "A", "B", or "C")	On request	
<b>7</b> Diagnostic modules (optional) <b>HD2-DM-B</b> (Basic) <b>HD2-DM-A</b> (Advanced) - DTM Diagnostic Manager (one of three is required)	On request	

## FOUNDATION Fieldbus-H1 – FieldBarrier in Ex (Haz.) area

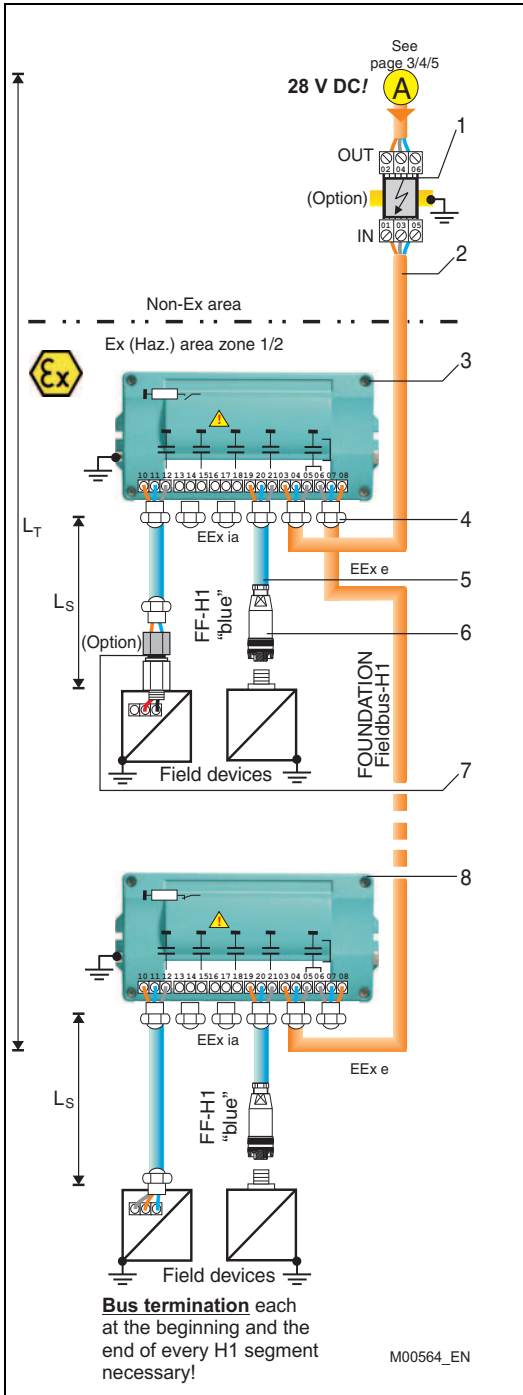

Description	Catalog No.	Data sheet
<b>1</b> H1 overvoltage protection, 2-channel, $I_N \leq 450$ mA (Optional) <b>NGV211-NO</b> - Cartridge for NGV210-NO <b>NGV210-NO</b> - Basic element for top-hat rail ♦ PINs: 1. channel: <b>IN:</b> 01 = H1+, 05 = H1-, 03 = shielding <b>OUT:</b> 02 = H1+, 06 = H1-, 04 = shielding 2. channel: <b>IN:</b> 07 = H1+, 11 = H1-, 09 = shielding <b>OUT:</b> 08 = H1+, 12 = H1-, 10 = shielding	63615-9 890 181 63615-9 890 180	10/63-6.15 10/63-6.15
<b>2</b> FOUNDATION Fieldbus-H1 cable, orange (No intrinsic safety) <b>NFC080-NO</b> - 0.88 mm <sup>2</sup> , 43.6 Ω/km, 65/330/1000 m <b>NFC150-NO</b> <sup>1)</sup> - 1.30 mm <sup>2</sup> , 27.4 Ω/km, 1000 m <b>NFC250-NO</b> <sup>1)</sup> - 2.10 mm <sup>2</sup> , 17.2 Ω/km, 1000 m	63668-9 890 16x 63668-9 890 169 63668-9 890 170	10/63-6.67 10/63-6.67 10/63-6.67
<b>3</b> <b>F2D0-FB-Ex4.CG</b> - FieldBarrier - IP 67, aluminium housing, II 2 (1G/D) G EEx me [ia] IIC T4 - 6x cable bushing plastic (shielding capacitive!), switchable bus termination. ♦ PINs: trunk cable ( $L_T$ ): <b>IN:</b> 03 = H1+, 04 = H1-, 05 = S <b>OUT:</b> 08 = H1+, 07 = H1-, 06 = S ♦ PINs: spur cable ( $L_S$ ): <b>4xOUT:</b> 10 = H1+, 11 = H1-, 12 = S / 13 = H1+, 14 = H1-, 15 = S 16 = H1+, 17 = H1-, 18 = S / 19 = H1+, 20 = H1-, 21 = S	On request	
<b>RD0-FB-Ex4</b> - FieldBarrier, IP 20, rail mounting (Alternative, not shown)	On request	
<b>4</b> <b>6x EMC cable bushing</b> (Shielding braid on ground via cable bushing)	Special order!	
<b>5</b> FOUNDATION Fieldbus-H1 cable, blue (Intrinsic safety) <b>NFC080-EX</b> - 0.88 mm <sup>2</sup> , 43.6 Ω/km, 65/330/1000 m	63668-9 890 17x	10/63-6.67
<b>6</b> <b>NFE300-NE</b> - H1 Kabelbuchse, IP 67 - Metal / plastic case, 7/8", for Ex (Haz.) and Non-Ex area ♦ PINs: 1 = H1-, 2 = H1+, 3 = shielding	3KDE636640L0102	10/63-6.60
<b>7</b> <b>NGV220-EX</b> <sup>2)</sup> - H1 overvoltage protection (optional) - IP 67 metal case, for M20 x 1.5 cable gland mounting, II2(1)G EEx ia IIC T4/T5/T6 ♦ PIN: <b>IN:</b> (+) = H1+, (-) = H1-, shielding on ground via EMC cable bushing ♦ PINs <b>OUT:</b> red = H1+, black = H1-, shielding on ground via metal case - Possible use at the FieldBarrier of the IN/OUT-PINs of the trunk cable ( $L_T$ ) by using EMC cable bushing (shielding capacity bridged).	63615-7 964 115	10/63-6.15
<b>8</b> <b>FieldBarrier</b> - Supply voltage per channel: $U_S$ 12.25 V (at 10 mA) up to 9.78 V (at 43 mA) - Supply current per channel: $I_S \leq 43$ mA - Basic current per FieldBarrier: $I_{basic} \leq 49$ mA	<p style="text-align: right;">M00538_EN</p>	
<b>Color coding:</b> <b>FOUNDATION Fieldbus-H1:</b> H1+ = orange H1- = blue		
<sup>1)</sup> By using the 1.3 / 2.1 mm <sup>2</sup> cable it is not possible to use plugs / sockets! <sup>2)</sup> By using the Field device types FXE4000, FV4000, FS4000 it is not possible to use NGV220!		

Limits and rules!	
When using the Power Hubs, FieldBarrier and ABB cable (by other Power Conditioner / Barriers / cable the limits are calculated new). <b>per FOUNDATION Fieldbus-H1 segment:</b> - number of H1 subscribers $\leq 16$ - number of FieldBarrier $\leq 4$ - $\Sigma$ current ( $I$ ) $\leq 450$ mA (max. current via NGV21x-NO) $\Sigma$ current ( $I$ ) = $\Sigma$ basic current of all Field devices and FieldBarriers + error current of one device - trunk cable length ( $L_T$ ) see diagram at $U_S$ min. 16.0 V DC of FieldBarrier (length depending on $\Sigma$ current and cable diameter) - spur cable length ( $L_S$ ) (acc. to the FISCO/IEC 60079-27 model): at 1 ... 12 spur cable: $L_S \leq 120$ m at 13 ... 14 spur cable: $L_S \leq 90$ m at 15 ... 16 spur cable: $L_S \leq 60$ m - cable length $L_{total} = L_T + (\Sigma L_S) \leq 1900$ m	<p style="text-align: right;">M00565_EN</p>

# FOUNDATION Fieldbus - Installation suggestion

## FOUNDATION Fieldbus-H1 – Passive T and 4-way junction (IP 66) in Non-Ex area

See page 3/4/5  
28 V DC!

OUT  
IN (Option)

FOUNDATION Fieldbus-H1

FF-H1 (Option)

Field devices

Bus termination each at the beginning and the end of every H1 segment necessary! M00567\_EN

Description	Catalog No.	Data sheet
<b>1</b> H1 overvoltage protection, 2-channel, $I_N \leq 450$ mA (Optional) <b>NGV211-NO</b> - Cartridge for NGV210-NO <b>NGV210-NO</b> - Basic element for top-hat rail ♦ PINs: 1. channel: IN: 01 = H1+, 05 = H1-, 03 = shielding    OUT: 02 = H1-, 06 = H1-, 04 = shielding 2. channel: IN: 07 = H1+, 11 = H1-, 09 = shielding    OUT: 08 = H1+, 12 = H1-, 10 = shielding	63615-9 890 181 63615-9 890 180	10/63-6.15 10/63-6.15
<b>2</b> FOUNDATION Fieldbus-H1 cable, orange <b>NFC080-NO</b> - 0.88 mm <sup>2</sup> , 43.6 Ω/km, 65/330/1000 m <b>NFC150-NO</b> <sup>1)</sup> - 1.30 mm <sup>2</sup> , 27.4 Ω/km, 1000 m	63668-9 890 16x 63668-9 890 169	10/63-6.67 10/63-6.67
<b>3</b> <b>NFJ120-NE</b> - H1 T-junction, IP 66 - 2x EMC cable bushing (Shielding braid on ground via cable bushing) ♦ PINs: trunk cable (L <sub>T</sub> ): IN/OUT: A = H1-, B = H1+	3KDE636630L0001	10/63-6.60
<b>4</b> <b>NFE100-NE</b> - H1 cable plug, IP 67 - Metal / plastic case, 7/8", for Ex (Haz.) and Non-Ex area ♦ PINs: 1 = H1-, 2 = H1+, 3 = shielding	3KDE636640L0101	10/63-6.60
<b>5</b> FOUNDATION Fieldbus-H1 cable, orange <b>NFC080-NO</b> - 0.88 mm <sup>2</sup> , 43.6 Ω/km, 65/330/1000 m	63668-9 890 16x	10/63-6.67
<b>6</b> <b>NGV220-NO</b> <sup>2)</sup> - H1 overvoltage protection (optional) - IP 67 metal case, for M20 x 1.5 cable gland mounting ♦ PINs: IN: (+) = H1+, (-) = H1-, shielding on ground via EMC cable bushing ♦ PINs: OUT: red = H1+, black = H1-, shielding on ground via metal case	63615-7 964 116	10/63-6.15
<b>7</b> <b>NPJ130-NO</b> - H1 T-junction, IP 66 - 3x EMC cable bushing, switchable bus termination (Shielding braid on ground via cable bushing) ♦ PINs: trunk cable (L <sub>T</sub> ): IN/OUT: A = H1-, B = H1+ ♦ PINs: spur cable (L <sub>S</sub> ): OUT: A = H1-, B = H1+	63643-9 890 102	10/63-6.60
<b>8</b> <b>NFE300-NE</b> - H1 cable socket, IP 67 - metal / plastic case, 7/8", for Ex (Haz.) and Non-Ex area ♦ PINs: 1 = H1-, 2 = H1+, 3 = shielding	3KDE636640L0102	10/63-6.60
<b>9</b> <b>NFJ420-NE</b> - H1 4-way junction, IP 66 - 2x EMC cable bushing, (Shielding braid on ground via cable bushing) ♦ PINs: trunk cable (L <sub>T</sub> ): IN/OUT: A = H1-, B = H1+ <b>NPJ460-NO</b> - H1 4-way junction, IP 66 - 6x EMC cable bushing, switchable bus termination (Alternative, not shown)	3KDE636630L0002 63643-9 890 104	10/63-6.60 10/63-6.60
<b>10</b> <b>NPZ100-EX</b> - H1 bus termination For NFJx20-NE needed only, IP 66	63645-9 890 120	10/63-6.60

**Color coding:**  
FOUNDATION Fieldbus-H1: H1+ = orange  
H1- = blue

<sup>1)</sup> By using the 1.3 mm<sup>2</sup> cable it is not possible to use plugs / sockets!  
<sup>2)</sup> By using the Field device types FXE4000, FV4000, FS4000 it is not possible to use NGV220!

### Limits and rules!

When using the Power Hubs and ABB junction & cable.  
(by other Power Conditioner / junction / cable the limits are calculated new)  
**per FOUNDATION Fieldbus-H1 segment:**

- number of H1 subscribers  $\leq 31$
- $\Sigma$  current (I)  $\leq 450$  mA (max. current via NGV21x-NO)  
 $\Sigma$  current (I) =  $\Sigma$  basic current of all field devices  
+ error current of one device
- trunk cable length (L<sub>T</sub>) of 0.88 mm<sup>2</sup> cable see diagram  
(length (L<sub>T</sub>) depending on  $\Sigma$  current, U<sub>s</sub> field device and cable diameter)
- spur cable length (L<sub>S</sub>):  
at 1 ... 12 spur cable: L<sub>S</sub>  $\leq$  120 m / at 13 ... 14 spur cable: L<sub>S</sub>  $\leq$  90 m  
at 15 ... 18 spur cable: L<sub>S</sub>  $\leq$  60 m / at 19 ... 24 spur cable: L<sub>S</sub>  $\leq$  30 m  
at 25 ... 31 spur cable: L<sub>S</sub>  $\leq$  1 m
- cable length L<sub>total</sub> = L<sub>T</sub> + ( $\Sigma$  L<sub>S</sub>)  $\leq$  1900 m

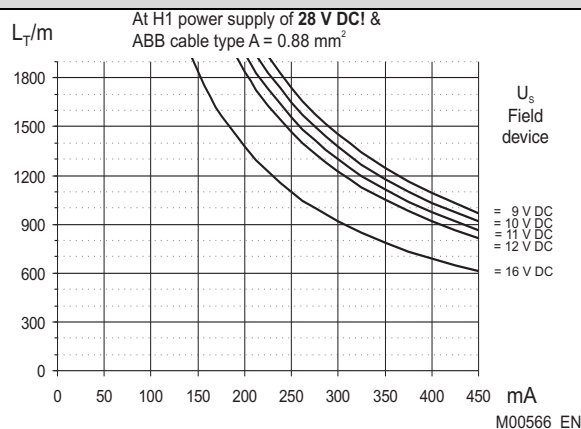

**FOUNDATION Fieldbus-H1 – Passive T-junction (IP 20) in Non-Ex area**

Description	Catalog No.	Data sheet
<b>1</b> H1 overvoltage protection, 2-channel, $I_N \leq 450$ mA (Optional) <b>NGV211-NO</b> - Cartridge for NGV210-NO <b>NGV210-NO</b> - Basic element for top-hat rail ♦ PINs: 1.channel: IN: 01 = H1+, 05 = H1-, 03 = shielding 2. channel: IN: 07 = H1+, 11 = H1-, 09 = shielding OUT: 02 = H1-, 06 = H1-, 04 = shielding OUT: 08 = H1+, 12 = H1-, 10 = shielding	63615-9 890 181 63615-9 890 180	10/63-6.15 10/63-6.15
<b>2</b> FOUNDATION Fieldbus-H1 cable, orange (No intrinsic safety) <b>NFC080-NO</b> - 0.88 mm <sup>2</sup> , 43.6 Ω/km, 65/330/1000 m <b>NFC150-NO</b> <sup>1)</sup> - 1.30 mm <sup>2</sup> , 27.4 Ω/km, 1000 m <b>NFC250-NO</b> <sup>1)</sup> - 2.10 mm <sup>2</sup> , 17.2 Ω/km, 1000 m	63668-9 890 16x 63668-9 890 169 63668-9 890 170	10/63-6.67 10/63-6.67 10/63-6.67
<b>3</b> H1 shield module, for stabilizing the fieldbus shield. ♦ PINs: Trunk cable (L <sub>T</sub> ): IN: S = shield (braided shield connected to ground via the module)	3KXN623100L0050	10/63-6.60
<b>4</b> H1 line-in module, for connecting the main line to the current-limiter modules, max. voltage 30 V DC, rated current 380 mA ♦ PINs: Trunk cable (L <sub>T</sub> ): IN: A = H1+, B = H1-	3KXN623100L0010	10/63-6.60
<b>5</b> H1 current-limiter module(s), max. 20 modules per line-in module, supply voltage U <sub>S</sub> = 17.5 V DC, supply current I <sub>S</sub> 62 mA ♦ PINs: spur cable (L <sub>S</sub> ): OUT: A = H1+, B = H1-	3KXN623100L0020	10/63-6.60
<b>6</b> H1 bus terminator module, at end of every main line for NGJ100-NE Terminal for segment expansion	3KXN623100L0040	10/63-6.60 On request
<b>NGJ100-NE</b> - Basic current per Line-In module: $I_{basic} \leq 5.0$ mA - Basic current per Current-Limiter module: $I_{basic} \leq 5.0$ mA		
<b>7</b> <b>NFE300-NE</b> - H1 cable socket, IP 67 - Metal / plastic case, 7/8", for Ex (Haz.) and Non-Ex area ♦ PINs: 1 = H1-, 2 = H1+, 3 = shielding	3KDE636640L0102	10/63-6.60
<b>8</b> <b>NGV220-NO</b> <sup>2)</sup> - H1 overvoltage protection (Optional) - IP 67 metal case, for M20 x 1.5 cable gland mounting ♦ PINs: IN: (+) = H1+, (-) = H1-, shielding on ground via EMC cable bushing ♦ PINs: OUT: red = H1+, black = H1-, shielding on ground via metal case	63615-7 964 116	10/63-6.15

**Color coding:**  
FOUNDATION Fieldbus-H1: H1+ = orange  
H1- = blue

<sup>1)</sup> By using the 1.3/2.1 mm<sup>2</sup> cable it is not possible to use plugs / sockets!  
By using the 2.1 mm<sup>2</sup> cable it is not possible to use NGV220-NO!  
<sup>2)</sup> By using the Field device types FXE4000, FV4000, FS4000 it is not possible to use NGV220!

**Limits and rules!**

When using the Power Hubs and ABB junction & cable (by other Power Conditioner / junction / cable the limits are calculated new).

**per FOUNDATION Fieldbus-H1 segment:**

- number of H1 subscribers  $\leq 15$
- $\Sigma$  current (I)  $\leq 450$  mA (max. current via NGV21x-NO)  
 $\Sigma$  current (I) =  $\Sigma$  basic current (all field devices, Line-In, Current-Limiter modules) + error current of one device
- trunk cable length (L<sub>T</sub>) of 0.88 mm<sup>2</sup> cable see diagram (length (L<sub>T</sub>) depending on  $\Sigma$  Strom, U<sub>S</sub> field device and cable diameter)
- spur cable length (L<sub>S</sub>):  
at 1 ... 12 spur cable: L<sub>S</sub>  $\leq 120$  m  
at 13 ... 14 spur cable: L<sub>S</sub>  $\leq 90$  m  
at 15 spur cable: L<sub>S</sub>  $\leq 60$  m
- cable length L<sub>total</sub> = L<sub>T</sub> + ( $\Sigma$  L<sub>S</sub>)  $\leq 1900$  m

At H1 power supply of 28 V DC! & ABB cable type A = 0.88 mm<sup>2</sup>

Y-axis: L<sub>T</sub>/m (0 to 1800)  
X-axis: mA (0 to 450)  
Legend: U<sub>S</sub> Field device: 9 V DC, 10 V DC, 11 V DC, 12 V DC, 16 V DC

# FOUNDATION Fieldbus - Installation suggestion

## FOUNDATION Fieldbus-H1 – Shielding and grounding

For information of shielding and grounding refer to the FOUNDATION Fieldbus Technical Guidelines (Http://www.fieldbus.org): Technical Guides: 31.25 kbit/s Intrinsic Safe Systems - AG-163, chapter 4.4

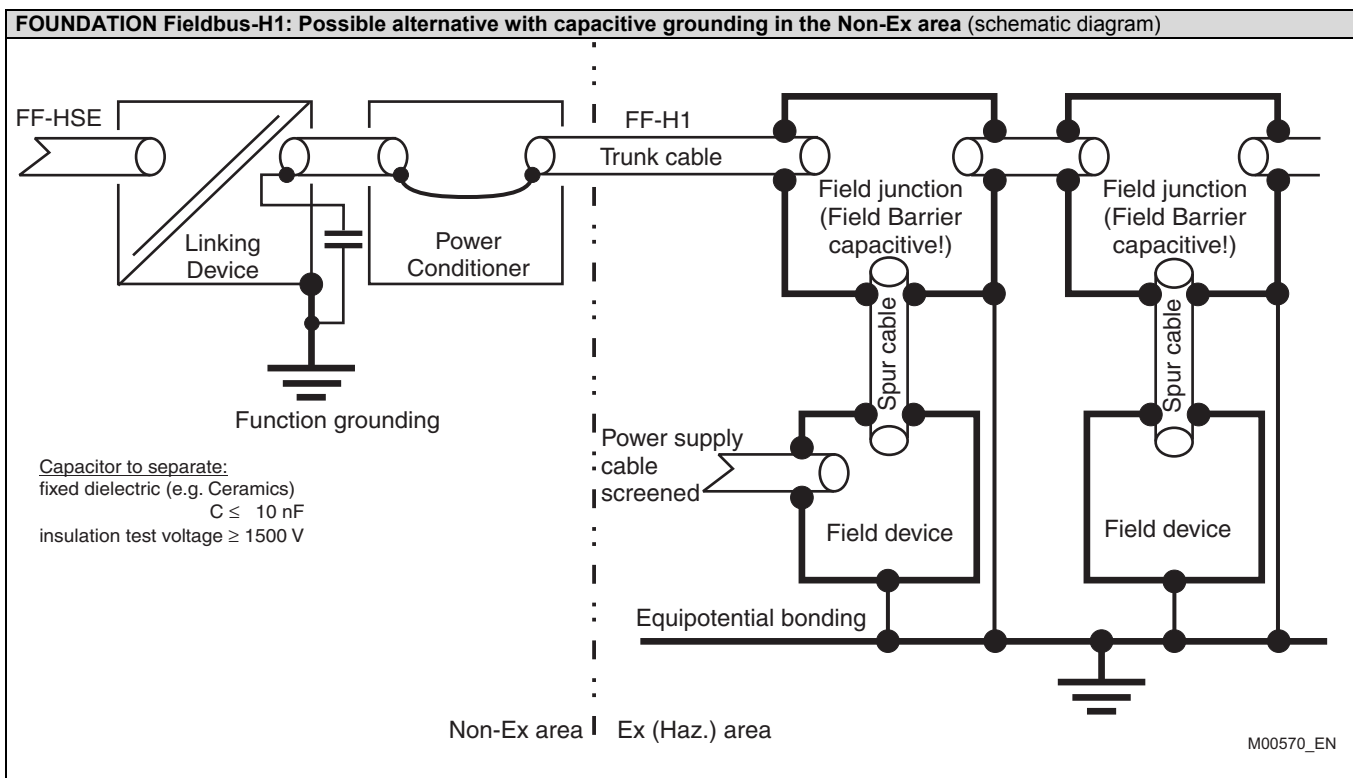
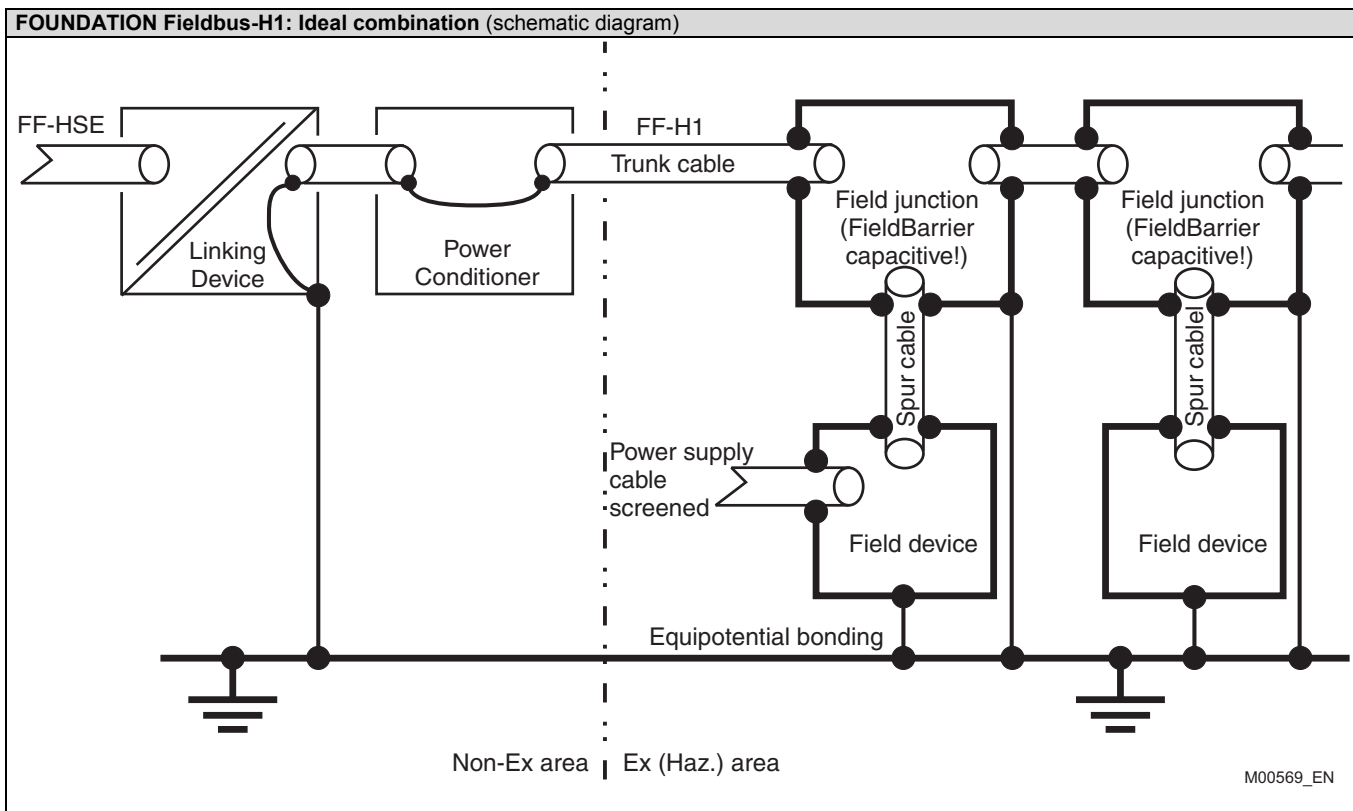

## FOUNDATION Fieldbus-H1 layout example – FieldBarrier in Ex (Haz.) area

Calculation example for one FOUNDATION Fieldbus-H1 segment: Number of H1 subscriber and cable length

Structure referring to the variant on page 6

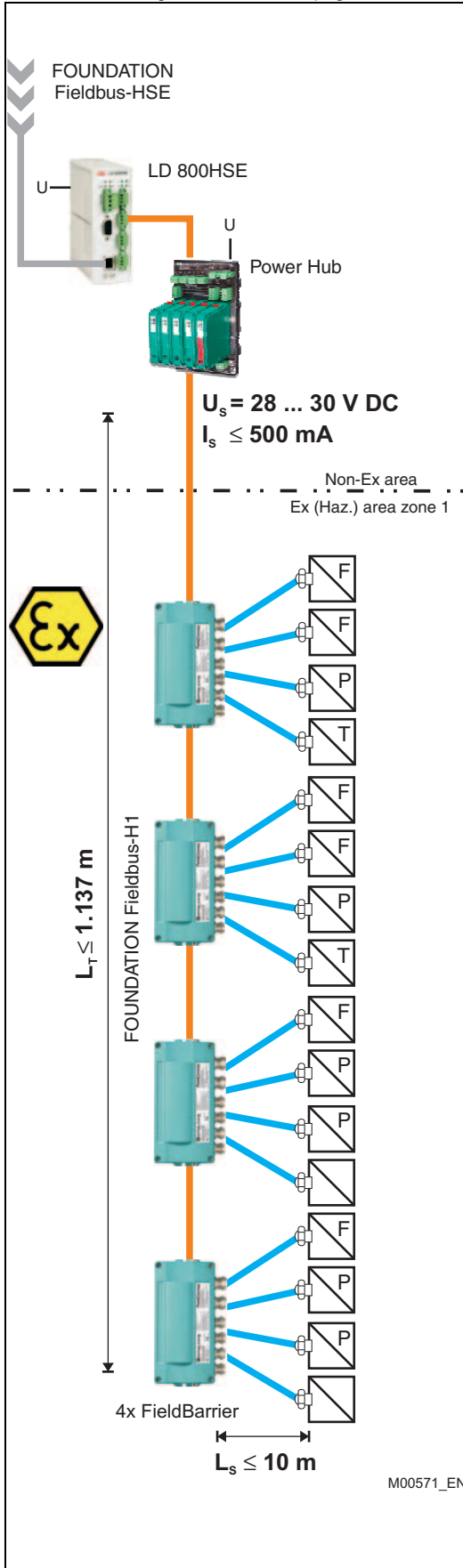

### Guideline:

- A H1 segment with 16 field devices in the **Ex (Haz.) area** for an application (e.g. Tank with a mixer)
- ABB field device types:
  - For Flow - 3x FV4000, 3x FXE4000
  - For Pressure - 3x 2600T(264xx), 3x 2600T(265xx)
  - For Temperature - 2x TF202-EX
  - For Positioning - 2x TZIDC-120
- Power supply by the Power Hub module HD2-FBPS-1.500 ( $U_s = 28 \dots 30 \text{ V DC}$ ,  $I_s \leq 500 \text{ mA}$ )
- **FieldBarrier F2D0-FB-Ex4.CG**
- Spur length per field device max. 10 m and  $L_T$  min. 750 m

### Question:

1. **Is the structure possible?**  
Referring to the current and voltage supply.
2. If yes, **which max. H1 segment cable length can be laid?**  
Referring to H1 cable of 1.30 mm<sup>2</sup>, from the Power Hub module up to the last H1 field device.

### Calculation:

Create a table with the FieldBarrier and the six field device types and fill in the  $U_{s \text{ Min.}}$ ,  $I_{\text{basic current}}$  and  $I_{\text{error current}}$ . These values are shown in the data sheet

“ABB Device overview for FOUNDATION Fieldbus-H1” (10/63-0.56).

H1 devices	$U_s \text{ Min.}$	$I_{\text{basic current}}$	$I_{\text{error current}}$
4x FieldBarrier	<b>16.0 V</b>	49.0 mA	---
3x FV4000	9.0 V	10.0 mA	3.0 mA
3x FXE4000	9.0 V	13.0 mA	4.0 mA
3x 2600T(264xx)	9.0 V	10.5 mA	<b>9.5 mA</b>
3x 2600T(265xx)	10.2 V	11.7 mA	5.6 mA
2x TF202-EX	9.0 V	10.5 mA	4.5 mA
2x TZIDC-120	9.0 V	11.5 mA	3.5 mA
		<b><math>\Sigma 375.6 \text{ mA}</math></b>	

1. Appraise and calculate (U, I):
  - for the voltage supply:  
Highest  $U_{s \text{ Min.}}$  (16.0 V)  
**is less than  $U_s = 28 \dots 30 \text{ V DC}$  of the Power Hub module.**
  - for the current supply:  
Sum  $I_{\text{basic current}}$  (375.6 mA) plus 1x highest  $I_{\text{error current}}$  (9.5 mA)  
**is less than  $I_s \leq 500 \text{ mA}$  of the Power Hub module.**
2. Calculation of the H1 segment length ( $L_T$ ):
  - Max.  $L_T$  is approx. 1.137 m  
Shown in the diagram page 6  
by means of the characteristic curve for the ABB H1 cable 1.30 mm<sup>2</sup> and of the sum current (0.3851 A)
  - Max. total length of the H1 segment cable is equal to  
 $L_{\text{max}} = 1.137 \text{ m} + L_S (16 \times 10 \text{ m}) = 1.297 \text{ m}$   
**is less than the max. allowed 1.900 m.**

### Result:

1. **The structure is possible in principle!**
2.  **$L_{\text{max}} = 1.297 \text{ m}$ .**

### Macro cycle time on the H1 segment at 31.25 kBit/s:

**min. 900 ms up to max. 2300 ms**

(Depending on the number of Publisher / Subscriber (Function Blocks).)

For the calculation of complex FOUNDATION Fieldbus topologies, bus cycle times and much more we recommend the ABB Layout Tool **DTE100** (Catalog No.: 3KDE633510L0001)

# FOUNDATION Fieldbus - Installation suggestion

## FOUNDATION Fieldbus-H1 layout example – Passive 4-way junction in Non-Ex area

Calculation example for one FOUNDATION Fieldbus-H1 segment: Number of H1 subscriber and cable length

Structure referring to the variant on page 7.

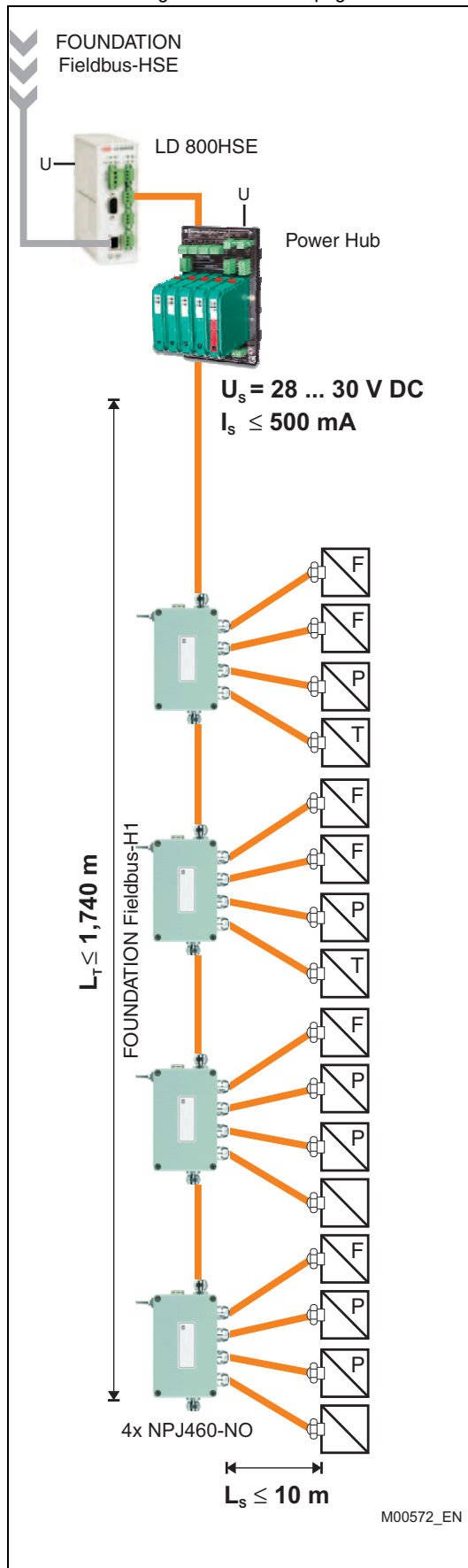

### Guideline:

- A H1 segment with 16 field devices in the **Non-Ex area** for an application (e.g. Tank with a mixer)
- ABB field device types:
  - For Flow - 3x FV4000, 3x FXE4000
  - For Pressure - 3x 2600T(264xx), 3x 2600T(265xx)
  - For Temperature - 2x TF202
  - For Positioning - 2x TZIDC-120
- Power supply by the Power Hub module HD2-FBPS-1.500 ( $U_s = 28 \dots 30 \text{ V DC}$ ,  $I_s \leq 500 \text{ mA}$ )
- **Passive 4-way junction** NPJ460-NO
- Spur length per field device max. 10 m and  $L_T$  min. 750 m

### Question:

1. **Is the structure possible?**  
Referring to the current and voltage supply.
2. If yes, **which max. H1 segment cable length can be laid?**  
Referring to H1 cable of  $0.88 \text{ mm}^2$ , from the Power Hub module up to the last H1 field device.

### Calculation:

Create a table with the six field device types and fill in the  $U_{s \text{ Min.}}$ ,  $I_{\text{basic current}}$  and  $I_{\text{error current}}$ .

These values are shown in the data sheet

“ABB Device overview for FOUNDATION Fieldbus-H1” (10/63-0.56).

H1 devices	$U_s \text{ Min}$	$I_{\text{basic current}}$	$I_{\text{error current}}$
4x NPJ460-NO	---	---	---
3x FV4000	9.0 V	10.0 mA	3.0 mA
3x FXE4000	9.0 V	13.0 mA	4.0 mA
3x 2600T(264xx)	9.0 V	10.5 mA	<b>9.5 mA</b>
3x 2600T(265xx)	<b>10.2 V</b>	11.7 mA	5.6 mA
2x TF202	9.0 V	10.5 mA	4.5 mA
2x TZIDC-120	9.0 V	11.5 mA	3.5 mA
		<b><math>\Sigma 179.6 \text{ mA}</math></b>	

1. Appraise and calculate (U, I):
  - for the voltage supply:  
Highest  $U_{s \text{ Min.}}$  (10.2 V)  
**is less than  $U_s = 28 \dots 30 \text{ V DC}$  of the Power Hub module.**
  - for the current supply:  
Sum  $I_{\text{basic current}}$  (179.6 mA) plus 1x highest  $I_{\text{error current}}$  (9.5 mA)  
**is less than  $I_s \leq 500 \text{ mA}$  of the Power Hub module**
2. Calculation of the H1 segment length ( $L_T$ ):
  - Max.  $L_T$  is  $> 1.900 \text{ m!}$   
Shown in the diagram page 7  
by means of the characteristic curve for the ABB H1 cable  $0.88 \text{ mm}^2$ , the sum current (0.1891 A) and highest  $U_{s \text{ Min.}}$  (10.2 V).
  - Max. total length of the H1 segment cable is equal to  
 $L_{\text{max}} = 1.900 \text{ m} + L_s (16 \times 10 \text{ m}) > 1.900 \text{ m!}$   
**Attention: Not exceed the max. allowed 1.900 m!**  
Max.  $L_T = 1.900 \text{ m} - L_s (16 \times 10 \text{ m}) = 1.740 \text{ m!}$

### Result:

1. **The structure is possible in principle!**
2.  $L_{\text{max}} = 1.900 \text{ m}$ .

### Macro cycle time on the H1 segment at 31.25 kBit/s:

**min. 900 ms up to max. 2300 ms**

(Depending on the number of Publisher / Subscriber (Function Blocks).)

For the calculation of complex FOUNDATION Fieldbus topologies, bus cycle times and much more we recommend the ABB Layout Tool **DTE100**:  
(Catalog No: 3KDE633510L0001)

# Contact us

## **ABB Automation Products GmbH**

Borsigstr. 2  
63755 Alzenau  
Germany

Phone: +49 551 905-534  
Fax: +49 551 905-555

**[www.abb.com](http://www.abb.com)**

### Note

We reserve the right to make technical changes or modify the contents of this document without prior notice. With regard to purchase orders, the agreed particulars shall prevail. ABB does not accept any responsibility whatsoever for potential errors or possible lack of information in this document.

We reserve all rights in this document and in the subject matter and illustrations contained therein. Any reproduction, disclosure to third parties or utilization of its contents - in whole or in parts - is forbidden without prior written consent of ABB.

Copyright© 2011 ABB  
All rights reserved

3KXN050000R1001

10/63-0.50 EN Rev. A 02.2011