

Earth-Fault Relay REJ 521

Technical Reference Manual



Contents

| | |
|---|-----------|
| 1. About this manual | 5 |
| 1.1. Copyrights | 5 |
| 1.2. Trademarks | 5 |
| 1.3. Guarantee | 5 |
| 1.4. General | 5 |
| 1.5. Use of symbols | 6 |
| 1.6. Terminology | 6 |
| 1.7. Related documents | 6 |
| 1.8. Document revisions | 6 |
| 2. Safety Information | 7 |
| 3. Introduction | 9 |
| 3.1. Use of the relay | 9 |
| 3.2. Features | 9 |
| 4. Instructions | 11 |
| 4.1. Application | 11 |
| 4.2. Requirements | 11 |
| 4.3. Configuration | 11 |
| 5. Technical Description | 13 |
| 5.1. Functional description | 13 |
| 5.1.1. Product functions | 13 |
| 5.1.1.1. Schema of product functions | 13 |
| 5.1.1.2. Earth-fault | 13 |
| 5.1.1.3. Inputs | 13 |
| 5.1.1.4. Outputs | 13 |
| 5.1.1.5. Circuit-breaker failure protection unit | 14 |
| 5.1.1.6. Disturbance recorder | 14 |
| 5.1.1.7. HMI module | 14 |
| 5.1.1.8. Non-volatile memory | 14 |
| 5.1.1.9. Self-supervision | 14 |
| 5.1.2. Measurements | 15 |
| 5.1.3. Configuration | 15 |
| 5.1.4. Protection | 16 |
| 5.1.4.1. Block diagram | 16 |
| 5.1.4.2. Earth-fault unit | 16 |
| 5.1.4.3. Time/current characteristics | 17 |
| 5.1.4.4. Settings | 26 |
| 5.1.4.5. Technical data on protection functions | 32 |
| 5.1.5. Indicator LEDs and alarm indication messages | 32 |
| 5.1.6. Commissioning test | 33 |

Technical Reference Manual

| | |
|---|-----------|
| 5.1.7. Disturbance recorder | 33 |
| 5.1.7.1. Function | 33 |
| 5.1.7.2. Disturbance recorder data | 33 |
| 5.1.7.3. Control and indication of disturbance recorder status | 34 |
| 5.1.7.4. Triggering | 35 |
| 5.1.7.5. Settings and unloading | 35 |
| 5.1.7.6. Event code of the disturbance recorder | 35 |
| 5.1.8. Recorded data of the last events | 35 |
| 5.1.9. External serial communication | 36 |
| 5.1.9.1. Communication ports | 36 |
| 5.1.9.2. IEC 60870-5-103 remote communication protocol | 37 |
| 5.1.9.3. Event codes | 40 |
| 5.1.9.4. SPA bus communication protocol parameters | 42 |
| 5.1.10. Self-supervision (IRF) system | 47 |
| 5.1.11. Relay parameterization | 48 |
| 5.2. Design description | 48 |
| 5.2.1. Input/output connections | 48 |
| 5.2.2. Serial communication connections | 50 |
| 5.2.3. Technical data | 51 |
| 6. Ordering Information | 55 |
| 7. Abbreviations | 57 |
| 8. Check Lists | 59 |
| 9. Service | 61 |
| 10. Index | 63 |

1. About this manual

1.1. Copyrights

The information in this document is subject to change without notice and should not be construed as a commitment by ABB Oy. ABB Oy assumes no responsibility for any errors that may appear in this document.

In no event shall ABB Oy be liable for direct, indirect, special, incidental or consequential damages of any nature or kind arising from the use of this document, nor shall ABB Oy be liable for incidental or consequential damages arising from use of any software or hardware described in this document.

This document and parts thereof must not be reproduced or copied without written permission from ABB Oy, and the contents thereof must not be imparted to a third party nor used for any unauthorized purpose.

The software or hardware described in this document is furnished under a license and may be used, copied, or disclosed only in accordance with the terms of such license.

Copyright © 2005 ABB Oy
All rights reserved.

1.2. Trademarks

ABB is a registered trademark of ABB Group.

All other brand or product names mentioned in this document may be trademarks or registered trademarks of their respective holders.

1.3. Guarantee

Please inquire about the terms of guarantee from your nearest ABB representative.

1.4. General

The purpose of this manual is to provide the user with thorough information on the protection relay REJ 521 and its applications, focusing on giving a technical description of the relay.

Refer to the Operator's Manual for instructions on how to use the Human-Machine Interface (HMI) of the relay, also known as the Man-Machine Interface (MMI), and to the Installation Manual for installation of the relay.

1.5. Use of symbols

This document includes warning, caution, and information icons that point out safety-related conditions or other important information. The corresponding icons should be interpreted as follows:



The electrical warning icon indicates the presence of a hazard which could result in electrical shock.



The caution icon indicates important information or warning related to the concept discussed in the text. It might indicate the presence of a hazard which could result in corruption of software or damage to equipment or property.



The information icon alerts the reader to relevant facts and conditions.

Although warning hazards are related to personal injury, and caution hazards are associated with equipment or property damage, it should be understood that operation of damaged equipment could, under certain operational conditions, result in degraded process performance leading to personal injury or death. Therefore, comply fully with all warning and caution notices.

1.6. Terminology

The following is a list of terms that you should be familiar with. The list contains terms that are unique to ABB or have a usage or definition that is different from standard industry usage.

| Term | Description |
|---------|---|
| IEC_103 | IEC 60870-5-103, a communication protocol standardized by the International Electrotechnical Commission |
| SPA | A data communication protocol developed by ABB |



1.7. Related documents

| Name of the manual | MRS number |
|----------------------------|----------------|
| REJ 521 Operator's Manual | 1MRS752179-MUM |
| RE_5__ Installation Manual | 1MRS750526-MUM |

1.8. Document revisions

| Version | Date | History |
|---------|------------|---|
| B | 15.08.2002 | |
| C | 14.11.2005 | Relay face plate updated. Manual layout updated. |

2.**Safety Information**

| | |
|---|---|
|  | Dangerous voltages can occur on the connectors, even though the auxiliary voltage has been disconnected. |
| | Non-observance can result in death, personal injury or substantial property damage. |
| | Only a competent electrician is allowed to carry out the electrical installation. |
| | National and local electrical safety regulations must always be followed. |
| | The frame of the device has to be carefully earthed. |
|  | The device contains components which are sensitive to electrostatic discharge. Unnecessary touching of electronic components must therefore be avoided. |
| | Breaking the sealing tape on the rear panel of the device will result in loss of warranty and proper operation will no longer be guaranteed. |

3. Introduction

3.1. Use of the relay

The earth-fault relay REJ 521 is intended for non-directional earth-fault protection in medium voltage distribution networks but can also be used for protection of generators, motors and transformers.

REJ 521 is based on a microprocessor environment. A self-supervision system continuously monitors the operation of the relay.

The HMI includes an Liquid Crystal Display (LCD) which makes the local use of the relay safe and easy.

Local control of the relay via serial communication can be carried out with a portable computer connected to the front connector and remote control via the rear connector connected to the distribution automation system through the serial interface and the fibre-optic bus.

3.2. Features

- Low-set non-directional earth-fault stage with definite-time or inverse definite minimum time (IDMT) characteristic
- High-set non-directional earth-fault stage with instantaneous or definite-time characteristic
- Circuit-breaker failure protection unit (CBFP)
- Disturbance recorder
 - recording time up to 28 seconds
 - triggering by a start or a trip signal from either of the two protection stages and/or by a binary input signal
 - records the analogue channel and five digital channels
 - adjustable sampling rate
- Non-volatile memory for
 - up to 60 event codes
 - setting values
 - disturbance recorder data
 - recorded data of the five last events with time stamp
 - number of starts for each stage
 - alarm indication messages and LEDs showing the status at the moment of power failure
- One accurate current input
- Galvanically isolated binary input with a wide input voltage range
- All settings can be modified with a personal computer
- HMI with an alphanumeric LCD and manoeuvring buttons
- IEC 60870-5-103 and SPA bus communication protocols
- Two normally open power output contacts

Technical Reference Manual

- Two change-over signal output contacts
- Output contact functions freely configurable for desired operation
- Optical PC-connector for two-way data communication (front)
- RS-485 connector (rear) for system communication
- Continuous self-supervision of electronics and software. At an internal relay fault (IRF), both protection stages and outputs are blocked.
- User-selectable rated frequency 50/60 Hz
- User-selectable password protection for the HMI
- Display of primary current values
- Multi-language support

4. Instructions

4.1. Application

The earth-fault relay REJ 521 is a secondary relay which is connected to the current transformers of the object to be protected. The earth-fault unit continuously measures the neutral current of the object. On detection of a fault, the relay will start, trip the circuit breaker, provide alarms, record fault data, etc., in accordance with the application and the configured relay functions.

The earth-fault unit includes low-set stage $I_{0>}$ and high-set stage $I_{0>>}$. If the high-set stage is given a setting value within the lower part of the setting range, the relay module will have two nearly identical stages. In this case, the relay can be used in two-stage load shedding applications.

The protection functions are independent of each other and have their own setting groups and data recordings. The earth-fault protection function uses conventional current transformer measurement.

An output contact matrix allows start or trip signals from the protection stages to be routed to the desired output contact.

4.2. Requirements

When the REJ 521 is operating under the conditions specified below (see Section 5.2.3. "Technical data" for further information), it will be practically maintenance-free. The relay includes no parts or components subject to abnormal physical or electrical wear under normal operating conditions.

Environmental conditions

- | | |
|--|-------------|
| • Specified ambient service temperature range | -10...+55°C |
| • Temperature influence on the operation accuracy of the protection relay within the specified ambient service temperature range | 0.1% / °C |
| • Transport and storage temperature range | -40...+70°C |

4.3. Configuration

Setting and connection example

The appropriate configuration of the output contact matrix enables the use of the signals from the earth-fault unit as contact functions. The start signals can be used for blocking co-operating protection relays, signalling and initiating autoreclosing.

Fig. 4.3.-1 represents the REJ 521 with the default configuration: all trips are routed to trip the circuit breaker.

Technical Reference Manual

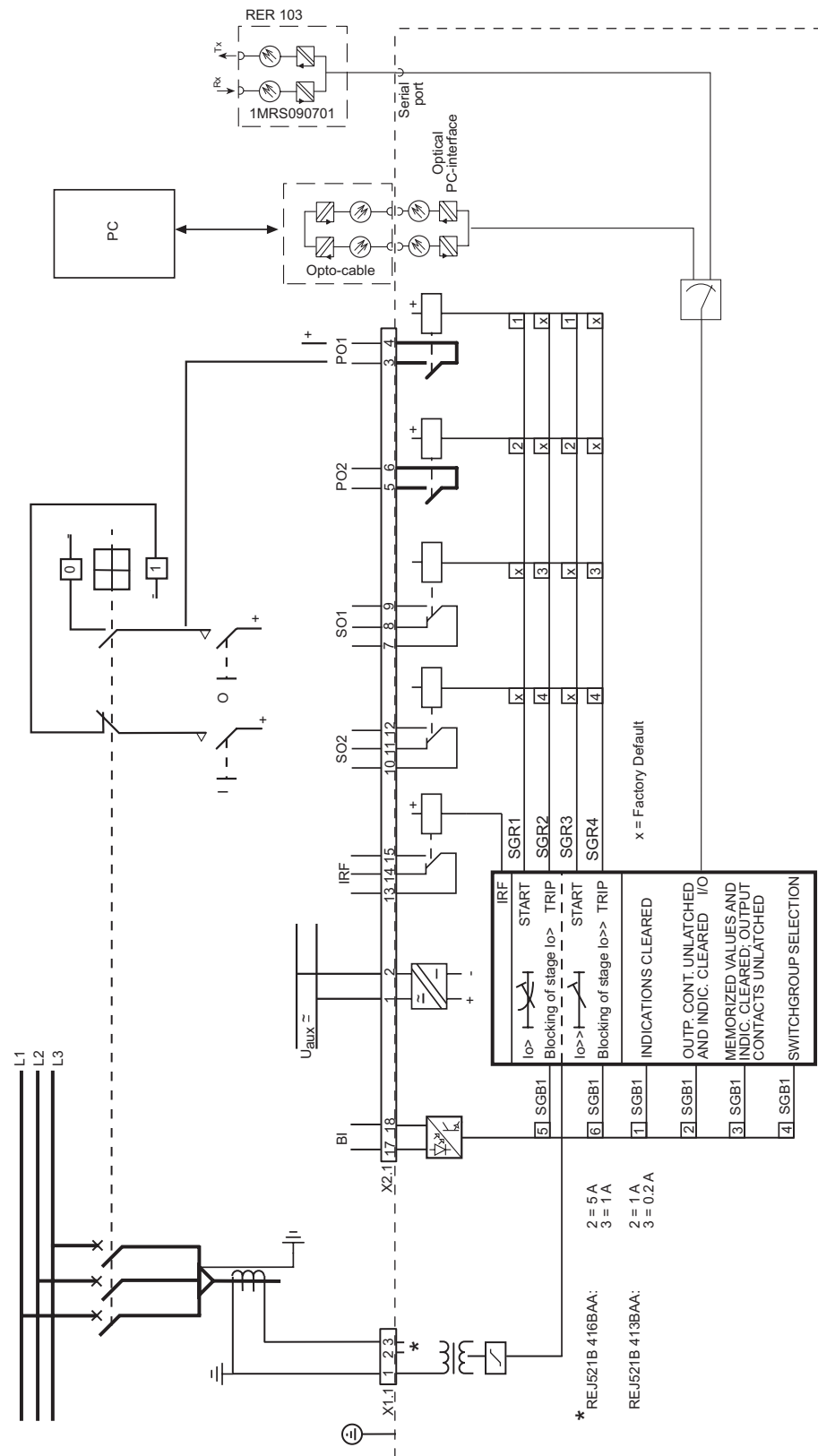

A051287

Fig. 4.3.-1 Connection diagram

5. Technical Description

5.1. Functional description

5.1.1. Product functions

5.1.1.1. Schema of product functions

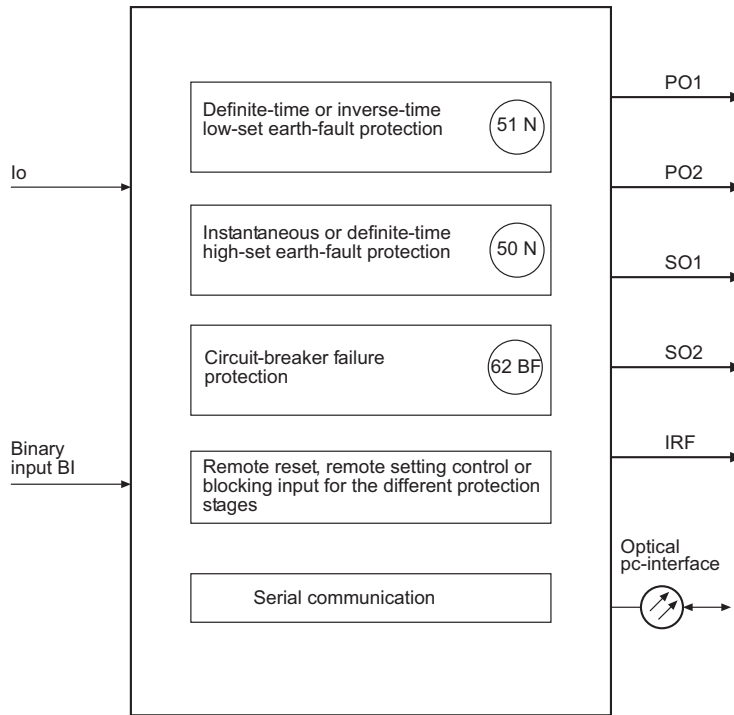

A051288

Fig. 5.1.1.1.-1 Product functions

5.1.1.2. Earth-fault

Refer to Section 5.1.4.2. "Earth-fault unit" .

5.1.1.3. Inputs

The REJ 521 includes one energizing input for the earth-fault current and one external binary input controlled by an external voltage. For details, refer to Section 5.2.1. "Input/output connections" and tables 5.1.4.4-5, 5.2.1-1 and 5.2.1-5. The function of the binary input is determined with the SGB switches.

5.1.1.4. Outputs

The REJ 521 is provided with two power outputs (PO1 and PO2) and two signal outputs (SO1 and SO2). Switchgroups SGR1...4 are used for routing start and trip signals from the protection stages to the desired signal or power output. PO1 and PO2 can be configured to be latched and the minimum pulse length to 40 or 80 ms.

5.1.1.5. Circuit-breaker failure protection unit

The REJ 521 features a circuit-breaker failure protection (CBFP) unit. The CBFP unit will generate a trip signal via output PO2 if the fault has not been cleared on expiration of the set operate time 0.10 s...1.00 s.

Normally, the CBFP unit controls the upstream circuit breaker. It can also be used for tripping via redundant trip circuits of the same circuit breaker. The CBFP unit is activated with a switch of switchgroup SGF1.

5.1.1.6. Disturbance recorder

The REJ 521 includes an internal disturbance recorder which records the momentary measured values, or the RMS curve of the measured signal, and five digital signals: the external binary input signal and the states of the internal protection stages. The disturbance recorder can be set to be triggered by a start or a trip signal from any protection stage and/or by an external binary input signal, and either on the falling or rising triggering edge.

5.1.1.7. HMI module

The HMI of the REJ 521 is equipped with six push-buttons and an alphanumeric 2x16 characters' LCD. The push-buttons are used for navigating in the menu structure and for adjusting set values.

An HMI password can be set to protect all user-changeable values from being changed by an unauthorised person. The HMI password will remain inactive and will thus not be required for altering parameter values until the default HMI password has been replaced. Entering the HMI password successfully can be selected to generate an event code. This feature can be used to indicate interaction activities via the local HMI. For further information on the HMI, refer to the Operator's Manual.

5.1.1.8. Non-volatile memory

The REJ 521 can be configured to store various data in a non-volatile memory, which will retain its data also in case of loss of auxiliary voltage. Alarm indication messages and LEDs, the number of starts, disturbance recorder data, event codes and recorded data can all be configured to be stored in the non-volatile memory whereas setting values will always be stored.

5.1.1.9. Self-supervision

The self-supervision system of the REJ 521 manages run-time fault situations and informs the user about an existing fault. When the self-supervision system detects a permanent internal relay fault, the READY indicator LED will start to blink. At the same time the self-supervision alarm relay (also referred to as the IRF relay), which is normally picked up, will drop off and a fault code will appear on the LCD. The fault code is numerical and identifies the fault type. For fault codes, refer to the Operator's Manual.

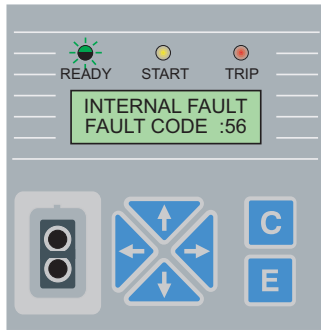

A051289

Fig. 5.1.1.9.-1 Internal fault

Fault codes can indicate:

- no response on the output contact test
- faulty program, work or parameter memory
- internal reference voltage error

5.1.2.

Measurements

The table below presents the measured value which can be accessed through the HMI, expressed as a multiple of the rated voltage, I_n , of the energizing input.

Table 5.1.2-1 Measurand values

| Indicator | Measured data |
|-----------|---------------------|
| I_0 | Earth-fault current |

5.1.3.

Configuration

The figure below illustrates how the start, trip and binary input signals can be configured to obtain the required protection functionality.

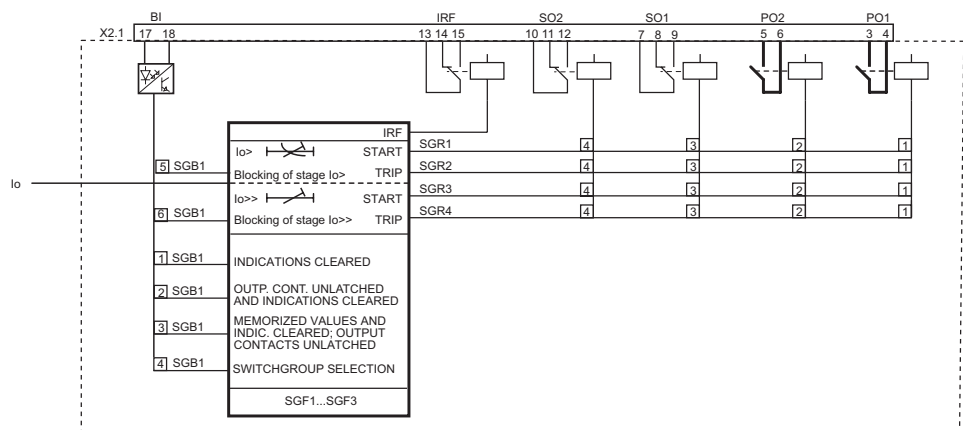

A051290

Fig. 5.1.3.-1 Signal diagram of REJ 521

The functions of the blocking and start signals are selected with the switches of switchgroups SGF, SGB and SGR. The checksums of the switchgroups are found under “SETTINGS” in the HMI menu. The functions of these switches are explained in detail in the corresponding SG_ -tables.

5.1.4.

Protection

5.1.4.1.

Block diagram

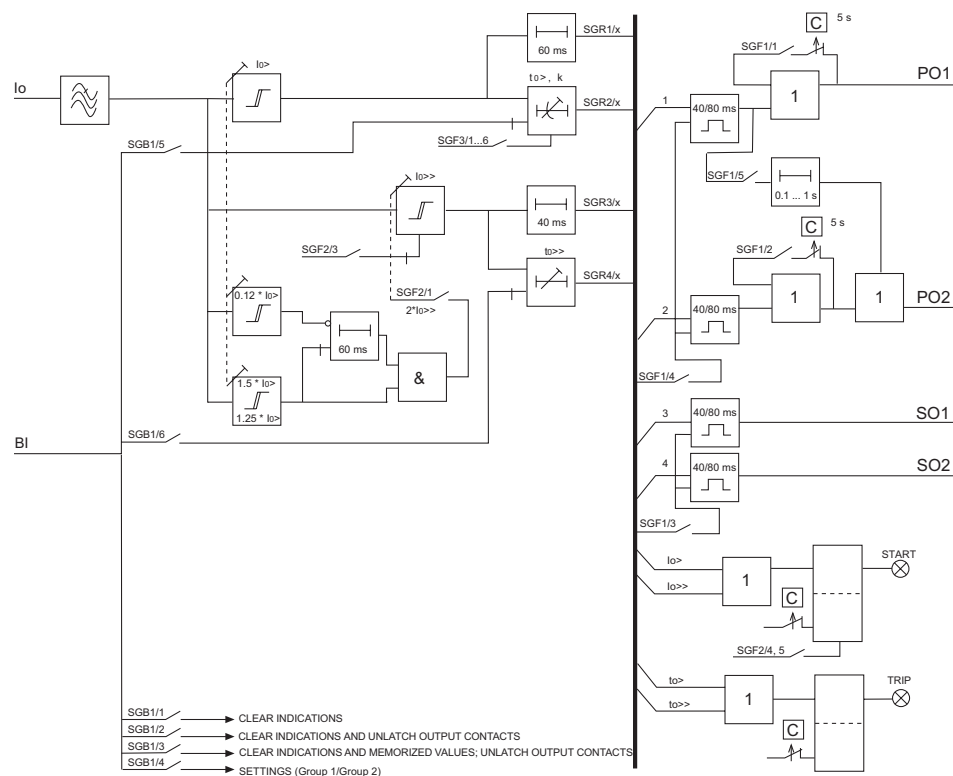

A051291

Fig. 5.1.4.1.-1 Block diagram

5.1.4.2.

Earth-fault unit

When the earth-fault current exceeds the set start value of low-set stage $I_0>$, the earth-fault unit will start to deliver a start signal after a ~ 60 ms’ start time. When the set operate time at definite-time characteristic or the calculated operate time at IDMT characteristic elapses, the earth-fault unit will deliver a trip signal.

When the earth fault current exceeds the set start value of high-set stage $I_0>>$, the earth-fault unit will start to deliver a start signal after a ~ 40 ms’ start time. When the set operate time elapses, the earth-fault unit will deliver a trip signal.

It is possible to block the start and the tripping of an earth-fault stage by applying an external binary input signal to the relay.

The inverse-time function of stage $I_{0>}$ can be set to be inhibited when stage $I_{0>>}$ starts with a switch of switchgroup SGF2. In this case the operate time will be determined by stage $I_{0>>}$.

The high-set stage can be set out of operation. This state will be indicated by dashes on the LCD and by "999" when the set start value is read via serial communication.

The set start value of stage $I_{0>>}$, $I_{0>>}/I_n$, can be automatically doubled in a start situation, e.g. when the object to be protected is connected to a distribution network. Thus a set start value below the connection inrush current level can be selected for stage $I_{0>>}$. A start situation is defined as a situation where the earth-fault current rises from a value below $0.12 \times I_{0>}$ to a value above $1.5 \times I_{0>}$ in less than 60 ms. The start situation ends when the current falls below $1.25 \times I_{0>}$.

5.1.4.3.

Time/current characteristics

The low-set earth-fault current stage can be given a definite-time or an inverse definite minimum time (IDMT) characteristic. The settings of switches SGF3/1...6 determine the operation mode of the stage. Refer to Section 5.1.4.4. "Settings" for additional information.

At IDMT characteristic, the operate time of the stage is dependent on the current value: the higher the current value, the shorter the operate time. Six time/current curve groups are available, of which four comply with the IEC 60255 standard: the normal inverse, very inverse, extremely inverse and long-time inverse. The two additional inverse-time curve groups, referred to as RI and RD, are special curve groups according to ABB praxis.

Characteristics according to the IEC 60255

The relay module incorporates four internationally standardised time/current curve groups called extremely inverse, very inverse, normal inverse and long-time inverse. The relationship between time and current is in accordance with the IEC 60255-3 standard and can be expressed as follows:

$$t[s] = \frac{k \times \beta}{\left(\frac{I_0}{I_{0>}}\right)^\alpha - 1}$$

where

t = operate time

k = time multiplier

I_0 = earth-fault current value

$I_{0>}$ = set start value.

Table 5.1.4.3-1 Values of the constants α and β

| Time/current curve group | α | β |
|--------------------------|----------|---------|
| Normal inverse | 0.02 | 0.14 |
| Very inverse | 1.0 | 13.5 |
| Extremely inverse | 2.0 | 80.0 |
| Long-time inverse | 1.0 | 120 |

According to the standard, the normal current range is 2...20 times the setting value at normal inverse, very inverse or extremely inverse characteristic. The relay is to start before the current exceeds the setting value by 1.3 times. At long-time inverse characteristic, the normal current range is specified to be 2...7 times the setting value, and the relay is to start before the current exceeds the setting value by 1.1 times.

Table 5.1.4.3-2 Operate time tolerances specified by the standard

| $I_0/I_{0>}$ | Normal | Very | Extremely | Long time |
|--------------|--------|-------|-----------|-----------|
| 2 | 2,22E | 2,34E | 2,44E | 2,34E |
| 5 | 1,13E | 1,26E | 1,48E | 1,26E |
| 7 | - | - | - | 1,00E |
| 10 | 1,01E | 1,01E | 1,02E | - |
| 20 | 1,00E | 1,00E | 1,00E | - |

E = accuracy in percent; - = not specified

Within the normal current range the inverse-time stage fulfils the tolerance requirements of class 5 at all degrees of inversivity.

The time/current characteristics according to the IEC and BS standards are illustrated in Fig. 5.1.4.3.-1...Fig. 5.1.4.3.-4.



If the ratio between the current and the set start value is higher than 20, the operate time will be the same as when the ratio is 20.

RI-type characteristic

The RI-type characteristic is a special characteristic which is principally used for obtaining time grading with mechanical relays. The characteristic can be expressed mathematically as follows:

$$t[s] = \frac{k}{0.339 - 0.236 \times \frac{I_{0>}}{I_0}}$$

where

t = operate time

k = time multiplier

I_0 = earth-fault current value

$I_{0>}$ = set start value

The RI-type characteristic is illustrated in Fig. 5.1.4.3.-5.

RD-type characteristic

The RD-type characteristic is a special characteristic which is principally used in earth-fault protection and which requires a high degree of selectivity even at high resistance faults. The protection can operate in a selective way even if it is not directional. Mathematically, the time/current characteristic can be expressed as follows:

$$t[s] = 5.8 - 1.35 \times \log_e \left(\frac{I_0}{k \times I_{0>}} \right)$$

where

t = operate time

k = time multiplier

I_0 = earth-fault current value

$I_{0>}$ = set start value

The RD-type characteristic is illustrated in Fig. 5.1.4.3.-6.

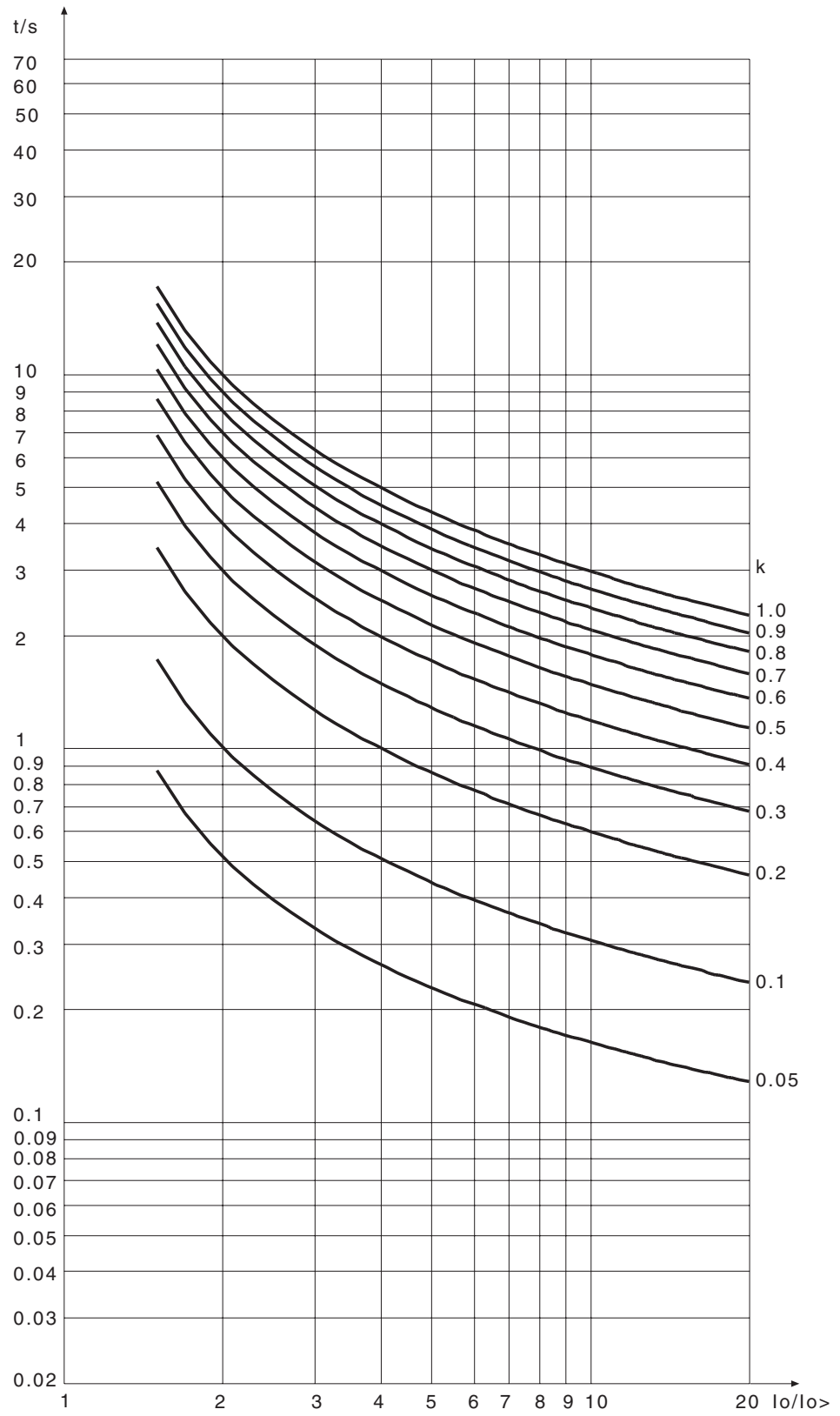

Fig. 5.1.4.3.-1 Normal inverse-time characteristic

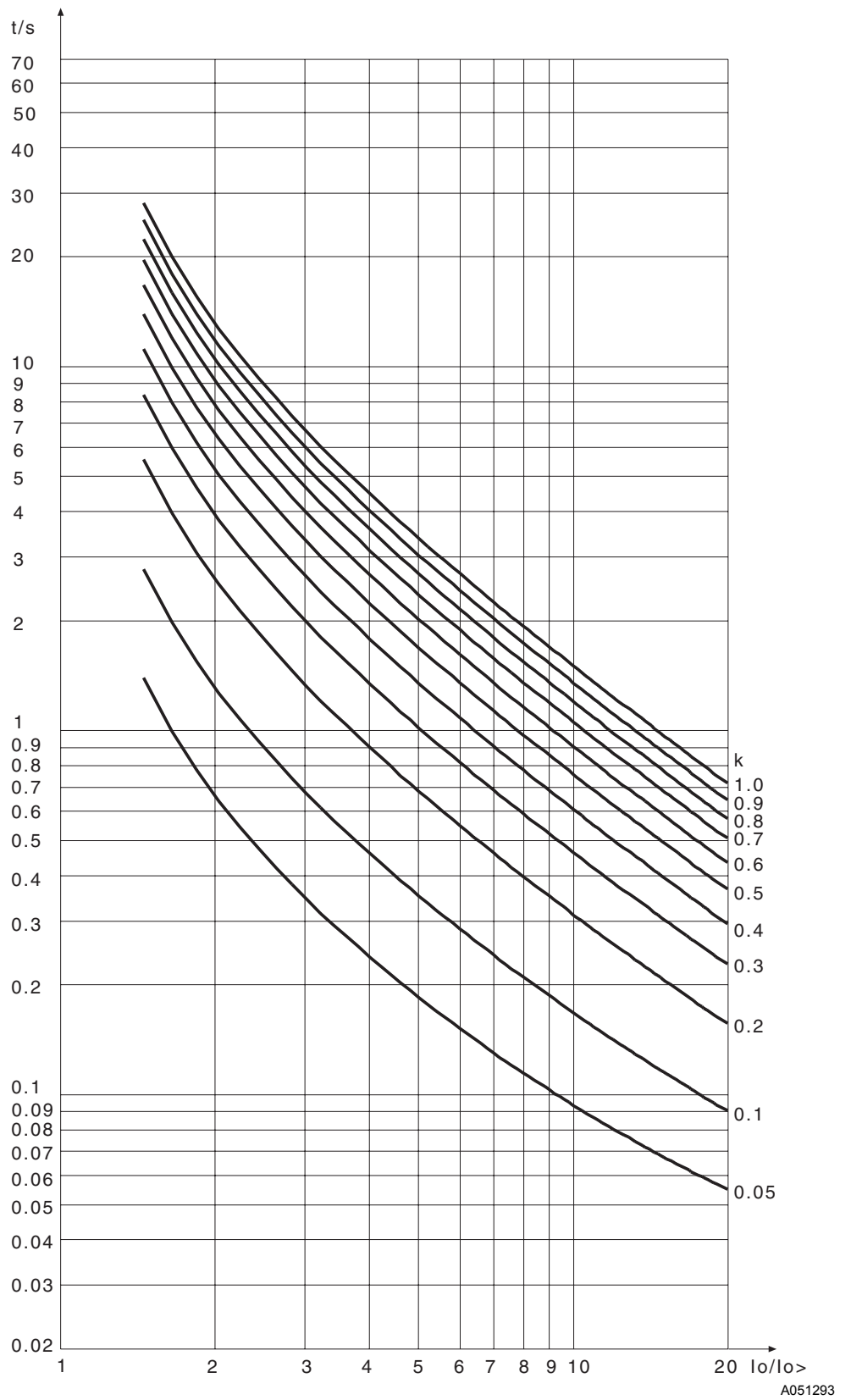

Fig. 5.1.4.3.-2 Very inverse-time characteristic

Technical Reference Manual

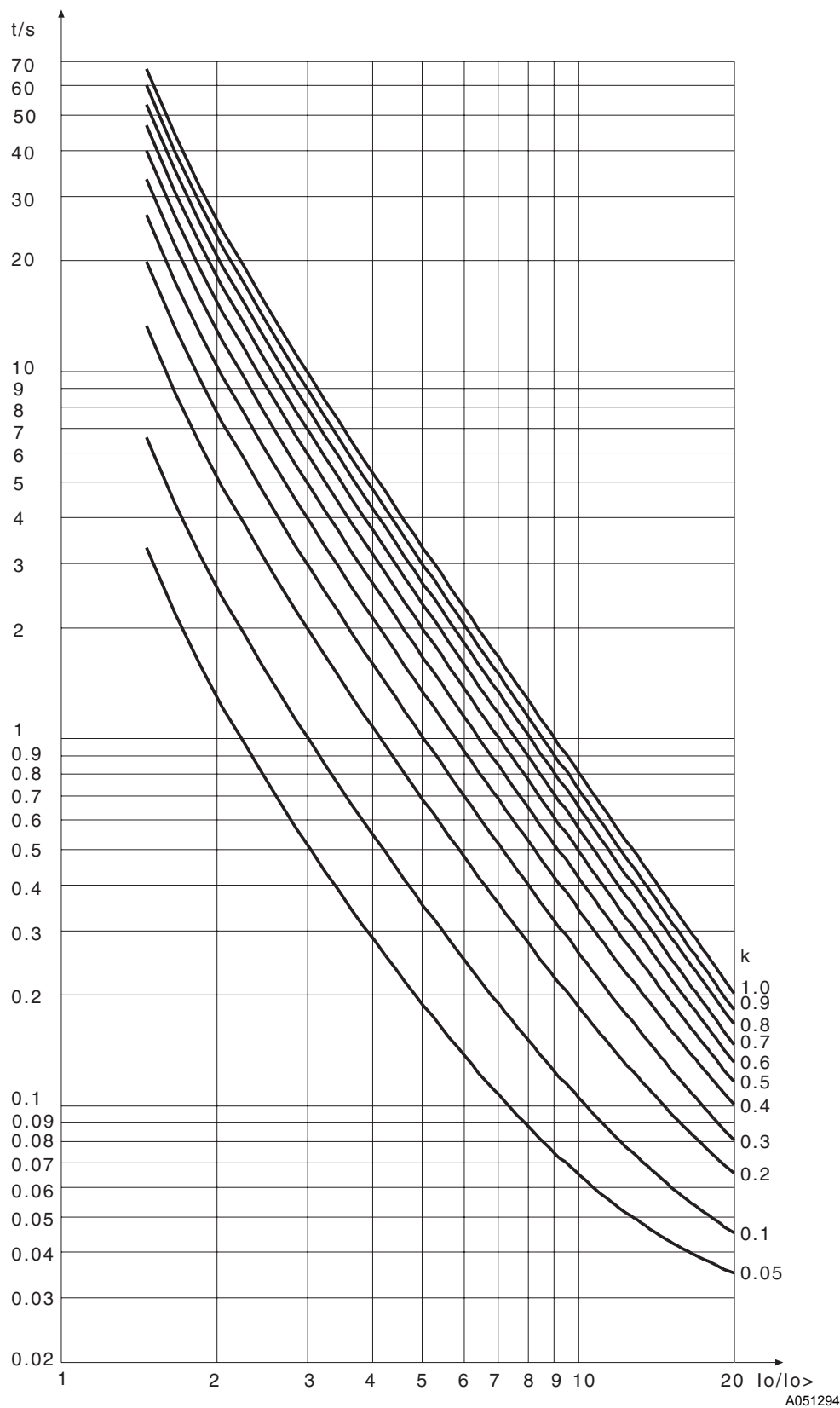

Fig. 5.1.4.3.-3 Extremely inverse-time characteristic

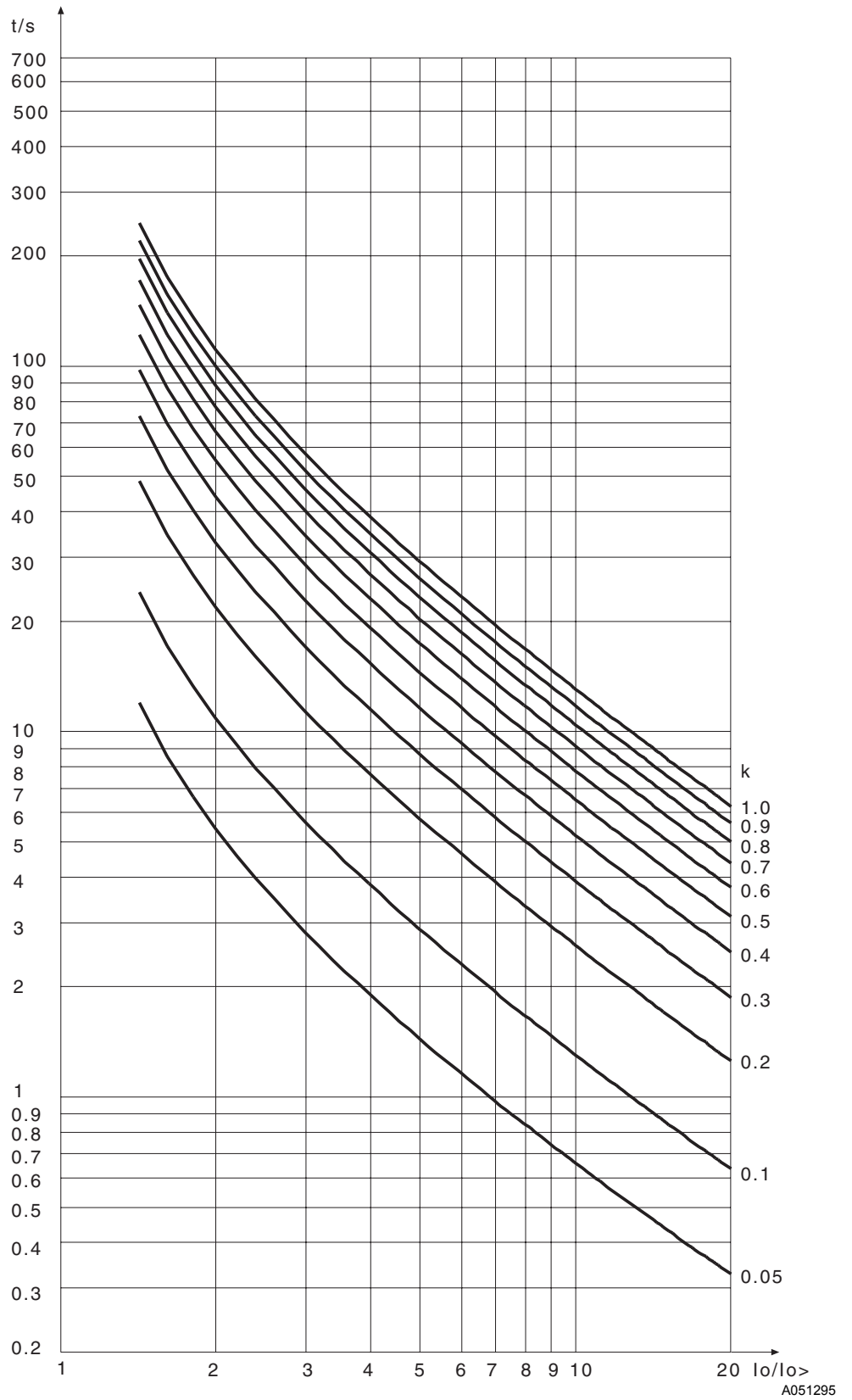

Fig. 5.1.4.3.-4 Long-time inverse-time characteristic

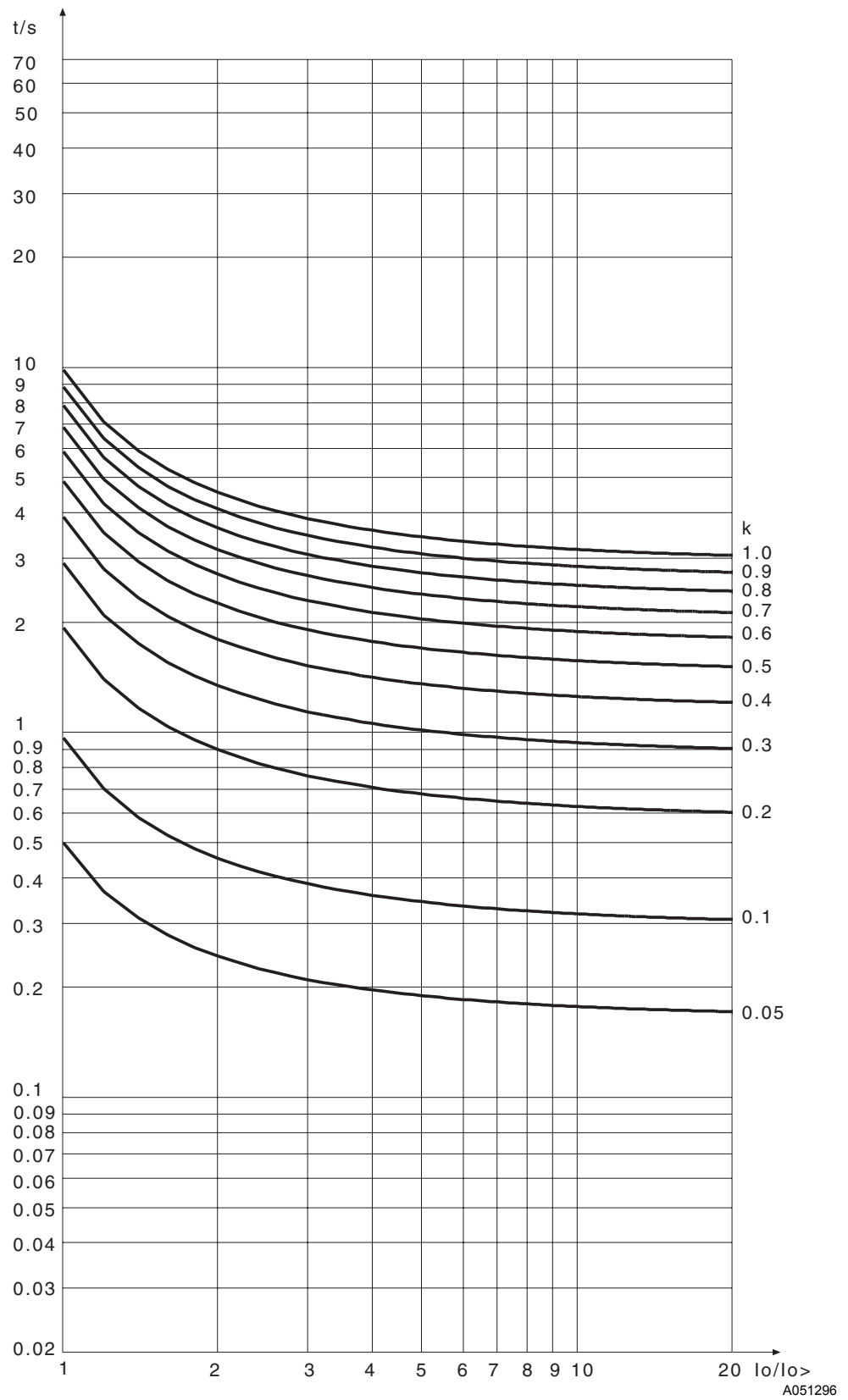

Fig. 5.1.4.3.-5 RI-type inverse-time characteristics

Technical Reference Manual

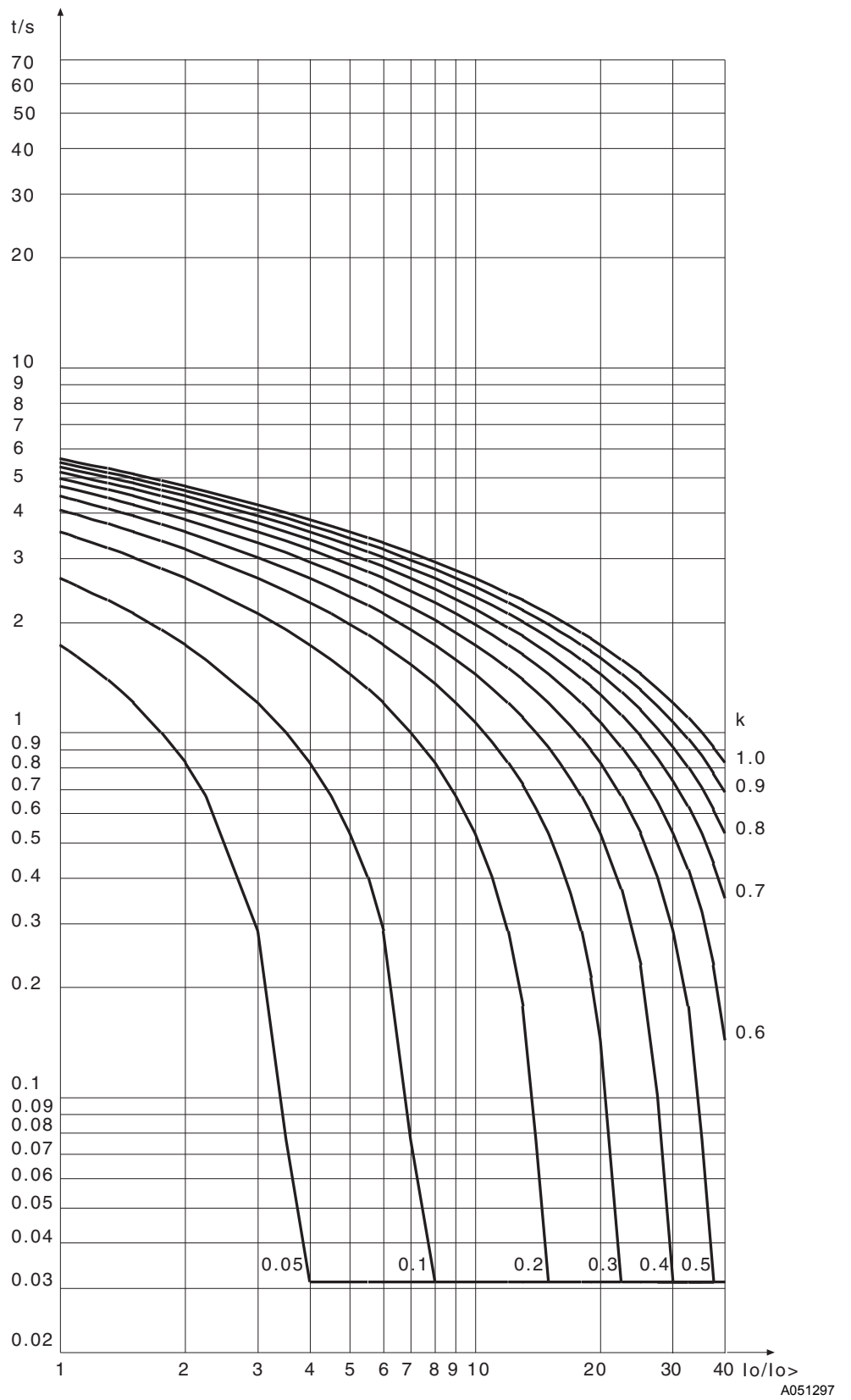

Fig. 5.1.4.3.-6 RD-type inverse-time characteristic

5.1.4.4.**Settings**

There are two alternative setting groups available, setting groups 1 and 2. Either of these setting groups can be used as the actual settings, one at a time. Both groups have their related registers. By switching between the setting groups a whole group of settings can be changed at the same time. This can be done in any of the following ways:

Group configuration:

- via the HMI
- entering parameter V150 via serial communication

Group selection:

- switching between Group1 and Group2 is accomplished by means of the external binary input

The setting values can be altered via the HMI or with a personal computer provided with the Relay Setting Tool.

Before the relay is connected to a system it must be assured that the relay has been given the correct settings. If there is any doubt, the setting values should be read with the relay trip circuits disconnected or tested with current injection, refer to Section 8. "Check Lists" for additional information

Table 5.1.4.4-1 Setting values

| Setting | Description | Setting range | Default setting |
|---------------|--|--|------------------------------|
| $I_{0>}/I_n$ | Set start value of stage $I_{0>}$ as a multiple of the energizing input • definite-time • inverse-time | 0.01...0.80 x I_n 0.01...0.40 x I_n ¹⁾ | 0.01 x I_n 0.01 x I_n |
| $t_{0>}$ | Operate time of stage $I_{0>}$ in seconds at definite-time characteristic | 0.05...300 s | 0.05 s |
| k_0 | Time multiplier k_0 of stage $I_{0>}$ at IDMT characteristic | 0.05...1.00 | 0.05 |
| $I_{0>>}/I_n$ | Set start value of stage $I_{0>>}$ as a multiple of the energizing input | 0.05...4.00 x I_n ²⁾ | 0.05 x I_n |
| $t_{0>>}$ | Operate time of stage $I_{0>>}$ in seconds | 0.04...300 s | 0.04 s |
| CBFP | Circuit-breaker failure protection | 0.10...1.00 s | 0.1 s |

¹⁾ At IDMT characteristic, the REJ 521 allows settings above 0.4 x I_n for stage $I_{0>}$, but regards any setting >0.4 x I_n as equal to 0.4 x I_n .

²⁾ The stage can be set out of operation in SGF. This state will be indicated by dashes on the LCD and by "999" when parameters are read via the SPA bus.

Switchgroups and parameter masks

The settings can be altered and the operation characteristics of the relay in various applications selected in the SG_selector switchgroups. The switchgroups are software based and thus not physical switches to be found in the hardware of the relay. The switches can be set one by one.

A checksum is used for verifying that the switches have been properly set. The figure below shows an example of manual checksum calculation.

| Switch number | Position | | Weighting factor | | Value |
|---------------|----------|---|------------------|---|-------|
| 1 | 1 | x | 1 | = | 1 |
| 2 | 0 | x | 2 | = | 0 |
| 3 | 1 | x | 4 | = | 4 |
| 4 | 0 | x | 8 | = | 0 |
| 5 | 1 | x | 16 | = | 16 |
| 6 | 0 | x | 32 | = | 0 |
| 7 | 1 | x | 64 | = | 64 |
| 8 | 0 | x | 128 | = | 0 |
| Checksum | | | SG_Σ | = | 85 |

Fig. 5.1.4.4.-1 An example of calculating the checksum of a SG_selector switchgroup

When the checksum, calculated according to the example above, equals the checksum of the relay, the switches in the switchgroup have been properly set.

The factory default settings of the switches and the corresponding checksums are presented in the tables below.

SGF1...SGF3

Switchgroups SGF1...SGF3 are used for configuring the desired function as follows:

Table 5.1.4.4-2 SGF1

| Switch | Function | Default setting |
|--------|---|-----------------|
| SGF1/1 | Selection of the latching feature for power output PO1 | 0 |
| SGF1/2 | Selection of the latching feature for power output PO2 • When the switch is in position 0 and the measuring signal which caused the trip falls below the set start value, the output contact will return to its initial state. • When the switch is in position 1, the output contact will remain active although the measuring signal which caused the trip falls below the set start value. A latched output contact can be unlatched either via the HMI, the external binary input or the serial bus. | 0 |
| SGF1/3 | Minimum pulse length for signal outputs SO1 and SO2 • 0=80 ms • 1=40 ms | 0 |

Table 5.1.4.4-2 SGF1 (Continued)

| Switch | Function | Default setting |
|--------|---|-----------------|
| SGF1/4 | Minimum pulse length for power outputs PO1 and PO2 <ul style="list-style-type: none"> • 0=80 ms • 1=40 ms Note! The latching function of PO1 and PO2 will overrun this function. | 0 |
| SGF1/5 | CBFP <ul style="list-style-type: none"> • When the switch is in position 0, the CBFP is not in use. • When the switch is in position 1, the signal to output PO1 will start a timer which will generate a delayed signal to output PO2, provided that the fault is not cleared before the CBFP operate time has elapsed. | 0 |
| SGF1/6 | Not in use | 0 |
| SGF1/7 | Not in use | 0 |
| SGF1/8 | Not in use | 0 |
| Σ SGF1 | | 0 |

Table 5.1.4.4-3 SGF2

| Switch | Function | Default setting |
|--------|---|-----------------|
| SGF2/1 | Automatic doubling of the set start value of stage $I_{0>>}$ <ul style="list-style-type: none"> • When the switch is in position 1, the set start value of the stage will automatically be doubled at high inrush situations. | 0 |
| SGF2/2 | Inverse-time operation of stage $I_{0>}$ inhibited by the start of stage $I_{0>>}$ <ul style="list-style-type: none"> • When the switch is in position 1, inverse-time operation is inhibited. | 0 |
| SGF2/3 | Inhibition of stage $I_{0>>}$ <ul style="list-style-type: none"> • When the switch is in position 1, stage $I_{0>>}$ is inhibited. | 0 |
| SGF2/4 | The operation mode of the start indication of stage $I_{0>}$ <ul style="list-style-type: none"> • 0 = the start indication will automatically be cleared once the fault has disappeared • 1 = latching. The start indication will remain active although the fault has disappeared. | 0 |
| SGF2/5 | The operation mode of the start indication of stage $I_{0>>}$ <ul style="list-style-type: none"> • 0 = the start indication will automatically be cleared once the fault has disappeared • 1 = latching. The start indication will remain active although the fault has disappeared. | 0 |
| SGF2/6 | Not in use | 0 |
| SGF2/7 | Not in use | 0 |
| SGF2/8 | Not in use | 0 |
| Σ SGF2 | | 0 |

Table 5.1.4.4-4 SGF3: $I_0 >$ characteristics

| SGF3/1 | SGF3/2 | SGF3/3 | SGF3/4 | SGF3/5 | SGF3/6 | SGF3/7 | SGF3/8 | Operation |
|--------|--------|--------|--------|--------|--------|--------|--------|-----------------------------|
| 0 | 0 | 0 | 0 | 0 | 0 | - | - | Definite-time ¹⁾ |
| 1 | 0 | 0 | 0 | 0 | 0 | - | - | Extremely inverse |
| 0 | 1 | 0 | 0 | 0 | 0 | - | - | Very inverse |
| 0 | 0 | 1 | 0 | 0 | 0 | - | - | Normal inverse |
| 0 | 0 | 0 | 1 | 0 | 0 | - | - | Long-time inverse |
| 0 | 0 | 0 | 0 | 1 | 0 | - | - | RI-type characteristic |
| 0 | 0 | 0 | 0 | 0 | 1 | - | - | RD-type characteristic |

¹⁾ Default setting



Only one type of characteristic can be selected at a time. If more than one switch is selected, the characteristic with the lowest weighting factor of the selected switches will be activated.

SGB1

Table 5.1.4.4-5 SGB1 Resetting/blocking with BI

| Switch | Function | Default setting |
|--------|---|-----------------|
| SGB1/1 | <ul style="list-style-type: none"> • 0 = indications are not cleared by the binary input signal • 1 = indications are cleared by the binary input signal | 0 |
| SGB1/2 | <ul style="list-style-type: none"> • 0 = indications are not cleared and latched output contacts are not unlatched by the binary input signal • 1 = indications are cleared and latched output contacts are unlatched by the binary input signal | 0 |
| SGB1/3 | <ul style="list-style-type: none"> • 0 = indications and memorized values are not cleared and latched output contacts are not unlatched by the binary input signal • 1 = indications and memorized values are cleared and latched output contacts are unlatched by the binary input signal | 0 |
| SGB1/4 | Switching between setting groups 1 and 2 using the external binary input <ul style="list-style-type: none"> • 0 = the setting group cannot be changed using the external binary input • 1 = the currently used setting group is determined by the binary input. When the binary input is energized, setting group 2 will be activated. Note! When SGB1/4 is set to 1, it is important that the switch has the same setting in both setting groups. | 0 |
| SGB1/5 | Blocking of stage $I_0 >$ by the binary input signal | 0 |
| SGB1/6 | Blocking of stage $I_0 >>$ by the binary input signal <ul style="list-style-type: none"> • When SGB1/5...6=1, tripping of the stage will be blocked by the external binary input signal. | 0 |

Table 5.1.4.4-5 SGB1 Resetting/blocking with BI (Continued)

| Switch | Function | Default setting |
|---------------|------------|-----------------|
| SGB1/7 | Not in use | 0 |
| SGB1/8 | Not in use | 0 |
| Σ SGB1 | | 0 |

SGR1...SGR4

The start and trip signals from the protection stages are connected to the output contacts with the switches of switchgroups SGR1...SGR4.

The matrix below can be of help when making the desired selections. The start and trip signals from both protection stages are combined with the output contacts by encircling the desired intersection point. Each intersection point is marked with a switch number, and the corresponding weighting factor of the switch is shown on the bottom line of the matrix. The switchgroup checksum is obtained by horizontally adding the weighting factors of all the selected switches of the switchgroup.

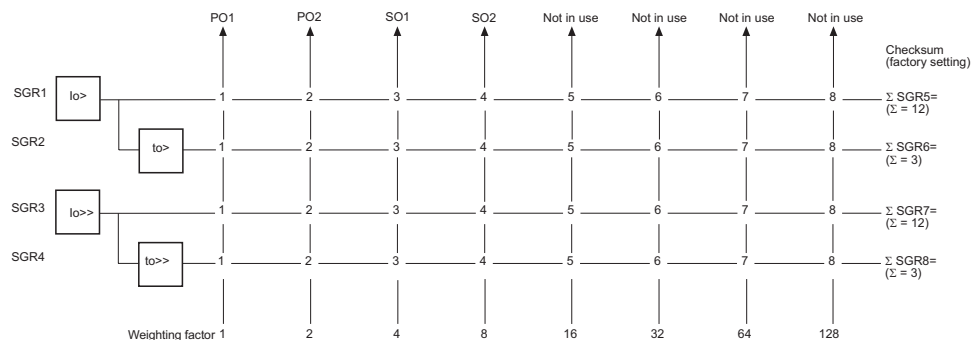

A051298

Fig. 5.1.4.4.-2 Output signal matrix

Table 5.1.4.4-6 SGR1...SGR4

| Switch | Function | Default setting |
|------------|---|-----------------|
| SGR1/1...4 | I ₀ > signal to output contacts PO1, PO2, SO1 and SO2 | 12 |
| SGR2/1...4 | t ₀ > signal to output contacts PO1, PO2, SO1 and SO2 | 3 |
| SGR3/1...4 | I ₀ >> signal to output contacts PO1, PO2, SO1 and SO2 | 12 |
| SGR4/1...4 | t ₀ >> signal to output contacts PO1, PO2, SO1 and SO2 | 3 |

New trip indication timer

The new trip indication timer can be configured to allow a second trip indication on the LCD. When both protection stages trip, the first trip indication will be displayed until the time, as specified by the “NEW TRIP IND.” setting value, has expired. After this, a new trip indication can displace the old one. The basic protection functions are not affected by the “NEW TRIP IND.” setting.

Table 5.1.4.4-7 New trip indication timer

| Setting | Description | Setting range | Default setting |
|---------------------|---|----------------|-----------------|
| New trip indication | New trip indication timer in minutes No new trip indication allowed until the previous one has been manually cleared | 0...998 999 | 60 |

Non-volatile memory settings

The table below presents data which can be configured to be stored in the non-volatile memory. All of the functions mentioned below can be selected separately with switches 1...5 in “MEMORY SETTINGS”.

Table 5.1.4.4-8 Memory settings

| Switch | Function | Default setting |
|----------|---|-----------------|
| 1 | • 0 = alarm indication messages and LEDs will be cleared • 1 = alarm indication messages and LEDs will be retained | 1 |
| 2 | • 1 = information on the “NUMBER OF STARTS” of the protection stages will be retained | 1 |
| 3 | • 1 = disturbance recorder data will be retained | 1 |
| 4 | • 1 = event codes will be retained | 1 |
| 5 | • 1 = recorded data will be retained | 1 |
| 6 | Not in use | 0 |
| 7 | Not in use | 0 |
| 8 | Not in use | 0 |
| checksum | | 31 |

5.1.4.5. Technical data on protection functions

| Feature | Stage $I_0 >$ ¹⁾ | Stage $I_0 \gg$ ¹⁾ |
|---|--|--|
| Set start value | | |
| • at definite-time characteristic | $0.01 \dots 0.80 \times I_n$ | $0.05 \dots 4.00 \times I_n$ ²⁾ |
| • at IDMT characteristic ³⁾ | $0.01 \dots 0.40 \times I_n$ | |
| Start time, typical | 60 ms | 40 ms |
| Time/current characteristics | | |
| • definite-time operate time $t >$ | 0.05...300 s | 0.04...300 s |
| • IDMT as per IEC 60255-3 | Extremely inverse Very inverse Normal inverse Long-time inverse | |
| • special type of inverse-time characteristic | RI-type inverse RD-type inverse | |
| time multiplier k | 0.05 ... 1.00 | |
| Resetting time | 40 or 80 ms | 40 or 80 ms |
| Drop-off/pick-up ratio, typical | 0.96 | 0.96 |
| Operate time accuracy at definite-time characteristic | $\pm 2\%$ of the set start value or ± 25 ms | $\pm 2\%$ of the set start value or ± 25 ms |
| Accuracy class index E at IDMT characteristic | 5 | |
| Operation accuracy | | |
| • $0.01 \dots 0.8 \times I_n$ | $\pm 3\%$ of the set start value $+0.05\% \times I_n$ | $\pm 3\%$ of the set start value $+0.05\% \times I_n$ |
| • $0.8 \dots 4.0 \times I_n$ | | $\pm 3\%$ of the set start value |

¹⁾ The start and the tripping of the low-set stage at IDMT characteristic can be blocked by the starting of the high-set stage, provided that this function has been selected in SGF. If set in SGF, the operate time will be determined by the set operate time of the high-set stage at heavy fault currents. In order to obtain a trip signal, the high-set stage must be routed to PO1 or PO2.

²⁾ The stage can be set out of operation in SGF. This state will be indicated by dashes on the LCD and by "999" when parameters are read via the SPA bus.

³⁾ At IDMT characteristic, the relay allows settings above $0.4 \times I_n$ for stage $I_0 >$, but regards any setting $> 0.4 \times I_n$ as equal to $0.4 \times I_n$.

5.1.5. Indicator LEDs and alarm indication messages

The operation of the REJ 521 can be monitored by means of three indicators on the front panel of the relay: a green READY indicator LED, a yellow START indicator LED and a red TRIP indicator LED (refer to the Operator's Manual for a more thorough presentation).

In addition, in case of an alarm from a protection stage, a text message will appear on the LCD.

The messages on the LCD have a certain priority order. If different types of indications are activated simultaneously, the message with the highest priority will appear on the LCD.

The priority order of the messages is:

1. CBFP
2. TRIP
3. START

5.1.6. Commissioning test

The function test is used for testing the configuration as well as the connections to and from the relay. By selecting this test the four internal signals from the protection stages and the IRF function can be activated and tested one by one. Provided that the internal signals from the protection stages have been set to be routed to the output contacts (PO1, PO2, SO1 and SO2) with the switches of SGR1...4, the output contacts will be activated and the corresponding event codes generated when the test is run. The test will not generate protection function event codes. Additionally, if the CBFP function is in use and PO1 is activated, PO2 will be activated, too.

The state of the binary input can be monitored by selecting the binary input test, and the LEDs can be turned on by selecting the LED test. Refer to the Operator's Manual for more detailed instructions on how to perform the tests.

5.1.7. Disturbance recorder

5.1.7.1. Function

The REJ 521 features an integrated disturbance recorder for recording monitored quantities. The recorder continuously captures the curve forms of the currents as well as the status of both the internal signals and the external binary input signal and stores these in the memory.

Triggering of the recorder will generate an event code. After the recorder has been triggered, it will continue to record data for a pre-defined post-triggering time. An asterisk will be shown on the LCD on completion of the recording. The status of the recording can also be viewed using a SPA parameter.

As soon as the recorder has been triggered and the recording has finished, the recording can be uploaded and analyzed by means of a PC provided with a special program.

5.1.7.2. Disturbance recorder data

One recording contains data from the analogue channel and the five digital channels for a preselected time. The analogue channel, whose data is stored either as an RMS curve or as momentary measured values, is the current measured by the relay. The digital channels, referred to as digital signals, are the start and trip signals from the protection stages and the external binary input signal linked to the relay.

The recording length varies according to the selected sampling frequency. The RMS curve is recorded by selecting the sampling frequency to be the same as the nominal frequency of the relay. The sampling frequency is selected with parameter M15; see the following table for details.

Table 5.1.7.2-1 Sampling frequency

| Nominal frequency Hz | Sampling frequency Hz | Cycles |
|-------------------------|--------------------------|--------|
| 50 | 800 | 90 |
| | 400 | 180 |
| | 50 ¹⁾ | 1440 |
| 60 | 960 | 90 |
| | 480 | 180 |
| | 60 ¹⁾ | 1440 |

¹⁾ RMS curve.

Recording length:

$$[s] = \frac{\text{Cycles}}{\text{Nominal frequency}[Hz]}$$

Changing the setting values of parameter M15 is allowed only when the recorder is not triggered.

The post-triggering recording length defines the time during which the recorder continues to store data after it has been triggered. The length can be changed with parameter V240. If the post-triggering recording length has been defined to be the same as the total recording length, no data stored prior to the triggering will be retained in the memory. By the time the post-triggering recording finishes, a complete recording will have been created.

Triggering of the recorder immediately after it has been cleared or the auxiliary voltage connected may result in a shortened total recording length. Disconnection of the auxiliary voltage after the recorder has been triggered but before the recording has finished, on the other hand, may result in a shortened post-triggering recording length. This, however, will not affect the total recording length.

At a power reset, triggered recorder data will be retained in the memory provided that it has been defined non-volatile.

5.1.7.3.

Control and indication of disturbance recorder status

It is possible to control and monitor the recording status of the disturbance recorder by writing to and reading parameters M1, M2 and V246. Reading parameter V246 will return either the value 0 or 1, indicating whether the recorder has not been triggered or triggered and ready to be uploaded. Event code E31 will be generated the moment the disturbance recorder is triggered. If the recorder is ready to be uploaded, this will also be indicated by an asterisk shown in the lower right-hand corner of the LCD when it is in the idle mode.

Writing the value 1 to parameter M2 will clear the recorder memory, restart the storing of new data and enable the triggering of the recorder. Recorder data can be cleared by performing a master reset. Writing the value 2 to parameter V246 will restart the unloading process by setting the time stamp and the first data ready to be read.

5.1.7.4. Triggering

The user can select the start or trip signal from any protection stage and/or the external binary input signal to trigger the disturbance recorder, either on the rising or falling edge of the signal(s). Triggering on the rising edge means that the post-triggering recording sequence will start when the signal is activated. Correspondingly, triggering on the falling edge means that the post-triggering recording sequence will start when the active signal is reset. The trigger signal(s) and the edge are selected with parameters V241...V244; see tables 5.1.9.4-5 and 5.1.9.4-6. The recorder can also be triggered manually using parameter M1.

Triggering of the disturbance recorder is only possible if the recorder has not already been triggered.

5.1.7.5. Settings and unloading

The setting parameters for the disturbance recorder are V parameters V241...V246 and M parameters M18, M20 and M80.

Unloading the recorder requires that M80 has been set. Unloading is done using a PC application. The uploaded recorder data is stored in separate files defined by the comtrade[®] format.

5.1.7.6. Event code of the disturbance recorder

The disturbance recorder generates an event code (E31) on triggering of the recorder by default. The event mask is defined using serial parameter V157.

5.1.8. Recorded data of the last events

The REJ 521 records up to five events. This enables the user to analyze the last five fault situations in the electrical power network. Each event includes the measured earth-fault current, start durations, and the time stamp. Additionally, information on the number of starts is provided.

Recorded data and the number of starts are non-volatile by default. A master reset will erase the contents of the recorded events and the number of starts.

The REJ 521 will start to collect data from both stages when a protection function starts. When each stage has dropped off, the collected data and the time stamp will be stored in the first event register and the four previously stored events will move one step forward. When a sixth event is stored, the oldest event will be cleared.

Table 5.1.8-1 Recorded data

| Register | Recorded data |
|------------------|--|
| EVENT 1 | <ul style="list-style-type: none"> The earth-fault current, I_0, measured as a multiple of the rated current, I_n, is displayed in two registers: the main register and the sub register. When the stage starts but does not trip, the maximum fault current during the pick-up period will be stored in both the main register and the sub register. When the stage trips, the fault current at the time of the trip will be stored in the main register and the maximum fault current during the pick-up period in the sub register. Duration of the last starts of stages $t_{0>}$ and $t_{0>>}$, expressed as a percentage of the set operate time, or of the calculated operate time at IDMT characteristic. The timing will start when a stage starts. A value other than zero means that the corresponding stage has started whereas a value which is 100% of the set or calculated operate time means that the stage has tripped. If the operate time for a stage has elapsed but the stage is blocked, the value will be 99% of the set or calculated operate time. Time stamp for the event. The time when the last stage drops off will be stored. The time stamp is displayed in two registers, one including the date expressed as yy-mm-dd, and the other including the time expressed as HH.MM; SS.sss. |
| EVENT 2 | Same as EVENT 1. |
| EVENT 3 | Same as EVENT 1. |
| EVENT 4 | Same as EVENT 1. |
| EVENT 5 | Same as EVENT 1. |
| Number of starts | <ul style="list-style-type: none"> The number of times each protection stage, i.e. $I_{0>}$ and $I_{0>>}$, has started, counting up to 999. |

5.1.9.

External serial communication

5.1.9.1.

Communication ports

The REJ 521 is provided with two serial communication ports: an optical PC-connection on the front panel and an RS-485 connection on the rear panel.

The D9S-type RS-485 connector is used to connect the relay to the distribution automation system. This connection enables the use of either the SPA bus communication protocol or the IEC 60870-5-103 communication protocol. The fibre-optic interface module RER 103 is used to connect the relay to the fibre-optic communication bus.

Although the RER 103 supports LON bus communication, the REJ 521 does not support the LON protocol. LON communication requires a separate LSG device.

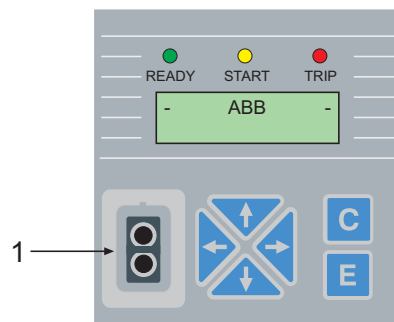

A051299

Fig. 5.1.9.1.-1 Front connector (1) for local communication

The relay is connected to a PC used for setting via the optical PC-connector on the front panel. The front interface uses the SPA bus protocol.

The optical PC-connector galvanically isolates the PC from the relay. The connection consists of a transmitter stage and a receiver stage. The front connector is standardized for ABB relay products and requires a specific opto-cable (ABB art. no 1MKC950001-2). The cable is connected to the serial RS-232C port of the PC. The optical stage of the cable is powered by RS-232C control signals.

The following serial communication parameters are to be used for RS-232C:

- Number of data bits 7
- Number of stop bits 1
- Parity even
- Baud rate 9.6 kbps as default

Relay data such as events, setting values and all input data and memorized values can be read via the optical PC-interface.

When setting values are altered via the optical PC-interface, the relay will check that the entered parameter values are within the permitted setting range. If an entered value is too high or too low, the setting value will remain unchanged.

The REJ 521 has an internal counter which can be accessed via “COMMUNICATION” under “CONFIGURATION” in the HMI menu. The counter value is set to 0 when the relay receives a valid message.

5.1.9.2.

IEC 60870-5-103 remote communication protocol

The REJ 521 supports the IEC 60870-5-103 remote communication protocol (henceforward referred to as the IEC_103) in the unbalanced transmission mode. The IEC_103 protocol is used to transfer measurand and status data from the slave to the master. However, the IEC_103 protocol cannot be used to transfer disturbance recorder data.

The IEC_103 protocol can be used only through the RS-485 connection on the rear panel. Connecting the REJ 521 to the fibre-optic communication bus requires the use of the fibre-optic interface module RER 103. The line-idle state of the RER 103 is “light off” whereas it is “light on” according to the IEC_103 standard. Therefore, to achieve full compatibility in the physical layer between the relay and the master, the

IEC 60870-5-103 star coupler RER 125 is required. The RER 125 is used to set the line-idle state “light off” to the relay and “light on” to the master. However, the RER 125 is not required if the master is compatible with the line-idle state “light off”.

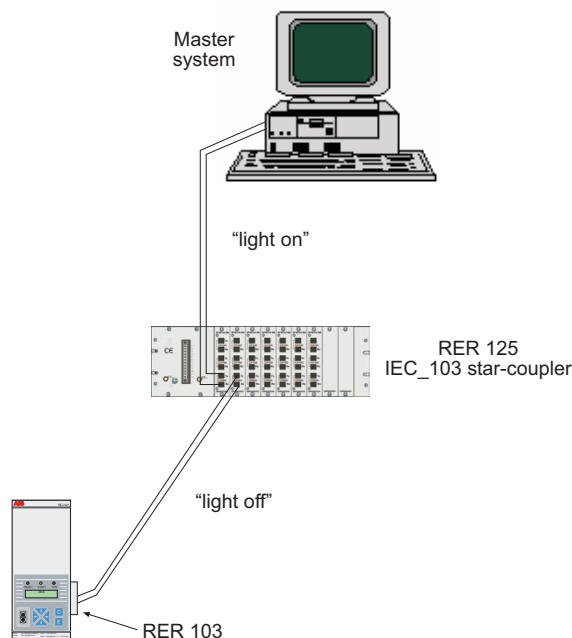

A051300

Fig. 5.1.9.2.-1 REJ 521 communication using the IEC_103 protocol

The REJ 521 will use the SPA bus protocol as default when the rear connection is in use. The IEC_103 protocol can be selected through the HMI of the relay. The selection is memorized and will therefore always be activated when the rear connection is in use. The use of the IEC_103 protocol in the REJ 521 requires a baud rate of 9.6 kbps. When the IEC_103 protocol has been selected, event masks are not in use. Therefore, all events in the configuration set are included in the event reporting.

The REJ 521 is provided with two different selectable configuration sets, of which configuration set 1 is used by default. Configuration set 1 provides full compatibility according to the IEC_103 standard. Configuration set 2 provides all applicable information of the protection equipment. However, some information elements have been mapped to a private range. Configuration set 255 is reserved for future use.

The tables below indicate the information mapping of the corresponding configuration sets. The column GI indicates whether the status of the specified information object is transmitted within the general interrogation cycle. The relative time in messages with the type identification 2 is calculated as a time difference between the occurred event and the event specified in the column Relative time. The measurand multiplied by the normalize factor is proportional to the rated value. Therefore, the maximum value of each measurand is the normalize factor multiplied by the rated value.

Table 5.1.9.2-1 Information mapping of configuration set 1

| Event reason | Event code | Function type | Information number | Standard description of the information number (IEC 60870-5-103) | GI | Relative time | Type identification |
|-------------------------------|-------------|---------------|--------------------|--|----|---------------|---------------------|
| I_0 > Start Activated/Reset | E1/ E2 | 160 | 67 | start/pick-up N | X | E1 | 2 |
| t_0 > Trip Activated/Reset | E3/ E4 | 160 | 92 | trip IN> | - | E1 | 2 |
| t_0 >> Trip Activated/Reset | E7/ E8 | 160 | 93 | trip IN>> | - | E1 | 2 |
| PO1 Activated/Reset | E9/ E10 | 160 | 27 | auxiliary input 1 | X | - | 1 |
| PO2 Activated/Reset | E11/ E12 | 160 | 28 | auxiliary input 2 | X | - | 1 |
| SO1 Activated/Reset | E15/ E16 | 160 | 29 | auxiliary input 3 | X | - | 1 |
| SO2 Activated/Reset | E17/ E18 | 160 | 30 | auxiliary input 4 | X | - | 1 |

Table 5.1.9.2-2 Information mapping of configuration set 1

| Measurand | Normalize factor | Rated value | Function type | Information number | Standard description of the information number (IEC 60870-5-103) | Type identification |
|---------------------------------|------------------|-------------|---------------|--------------------|--|---------------------|
| Current I_0 | 2.40 | I_n | 160 | 147 | measurand I | 3.4 |
| Voltage U_0 (not measured) | - | - | | | | |

Table 5.1.9.2-3 Information mapping of configuration set 2

| Event reason | Event code | Function type | Information number | Standard description of the information number (IEC 80870-5-103) | GI | Relative time | Type identification |
|--------------------------------|-------------|---------------|--------------------|--|----|---------------|---------------------|
| $I_0 >$ Start Activated/Reset | E1/ E2 | 160 | 67 | start/pick-up N | X | E1 | 2 |
| $t_0 >$ Trip Activated/Reset | E2/ E4 | 160 | 92 | trip IN> | - | E1 | 2 |
| $I_0 >>$ Start Activated/Reset | E5/ E6 | 162 | 95 | - | X | E5 | 2 |
| $t_0 >>$ Trip Activated/Reset | E7/ E8 | 160 | 93 | trip IN>> | - | E5 | 2 |
| PO1 Activated/Reset | E9/ E10 | 160 | 27 | auxiliary input 1 | X | - | 1 |
| PO2 Activated/Reset | E11/ E12 | 160 | 28 | auxiliary input 2 | X | - | 1 |
| SO1 Activated/Reset | E13/ E14 | 160 | 29 | auxiliary input 3 | X | - | 1 |
| SO2 Activated/Reset | E15/ E16 | 160 | 30 | auxiliary input 4 | X | - | 1 |
| Disturbance recorder triggered | E31 | 162 | 100 | - | - | - | 1 |
| HMI Password Opened/Closed | E32/ E33 | 162 | 101 | - | - | - | 1 |

Table 5.1.9.2-4 Information mapping of configuration set 2

| Measurand | Normalize factor | Rated value | Function type | Information number | Standard description of the information number (IEC 60870-5-103) | Type identification |
|---------------------------------|------------------|-------------|---------------|--------------------|--|---------------------|
| Current I_0 | 2.40 | I_n | 160 | 147 | measurand I | 3.4 |
| Voltage U_0 (not measured) | - | - | | | | |

5.1.9.3.**Event codes**

Special codes have been determined to represent certain events, such as start and tripping of protection stages and different states of output signals.

Events E1...E51 are stored in the event register of the relay. The maximum capacity of the register is 60 events. Under normal conditions the register is empty.

Technical Reference Manual

The contents of the register can be read using the L command, five events at a time. Using the L command erases the previously read events from the register, with the exception of events E50 and E51 which have to be reset using the C command. Should a fault occur, for example in data communication, these events can be re-read using the B command. If needed, the B command can also be repeated.

Events to be included in the event reporting are marked with multiplier 1. The event mask is formed by the sum of the weighting factors of all those events that are to be included in event reporting.

Table 5.1.9.3-1 Event masks

| Event mask | Code | Setting range | Default setting |
|------------|-----------|---------------|-----------------|
| V155 | E1...E8 | 0...255 | 85 |
| V156 | E9...E16 | 0...255 | 3 |
| V157 | E31...E33 | 0...7 | 1 |

Table 5.1.9.3-2 Event codes E1...E8

| Code | Event | Weighting factor | Default value |
|----------------------------------|--|------------------|---------------|
| E1 | Start of stage I ₀ > | 1 | 1 |
| E2 | Start of stage I ₀ > reset | 2 | 0 |
| E3 | Trip of stage I ₀ > | 4 | 1 |
| E4 | Trip of stage I ₀ > reset | 8 | 0 |
| E5 | Start of stage I ₀ >> | 16 | 1 |
| E6 | Start of stage I ₀ >> reset | 32 | 0 |
| E7 | Trip of stage I ₀ >> | 64 | 1 |
| E8 | Trip of stage I ₀ >> reset | 128 | 0 |
| Default value of event mask V155 | | | 85 |

Table 5.1.9.3-3 Event codes E9...E16

| Code | Event | Weighting factor | Default value |
|----------------------------------|---------------|------------------|---------------|
| E9 | PO1 activated | 1 | 1 |
| E10 | PO1 reset | 2 | 1 |
| E11 | PO2 activated | 4 | 0 |
| E12 | PO2 reset | 8 | 0 |
| E13 | SO1 activated | 16 | 0 |
| E14 | SO1 reset | 32 | 0 |
| E15 | SO2 activated | 64 | 0 |
| E16 | SO2 reset | 128 | 0 |
| Default value of event mask V156 | | | 3 |

Table 5.1.9.3-4 Event codes E31...E33

| Code | Event | Weighting factor | Default value |
|----------------------------------|--------------------------------|------------------|---------------|
| E31 | Disturbance recorder triggered | 1 | 1 |
| E32 | HMI password opened | 2 | 0 |
| E33 | HMI password reclosed | 4 | 0 |
| Default value of event mask V157 | | | 1 |

Explanations of the default values:

0 = not included in the event reporting

1 = included in the event reporting

Table 5.1.9.3-5 Event codes E50 and E51

| Code | Event |
|------|----------------------------|
| E50 | Restart of relay |
| E51 | Overflow of event register |

Events E50 and E51 are always included in the event reporting.

5.1.9.4.

SPA bus communication protocol parameters

In some cases, altering parameter values via serial communication requires the use of the SPA password. The password is a number within the range 1...999, the default value being 1.

To enter the setting mode, enter the password into parameter V160. To quit the setting mode, enter the same password into parameter V161. The password protection is also reactivated in case of loss of auxiliary voltage.

The HMI password can be changed via parameter V162, but it is not possible to read the password via this parameter.

Abbreviations used in following tables:

- R = readable data
- W = writeable data
- P = password protected writeable data
- I = input data
- S = setting values
- V = recorded data/parameter
- M = disturbance recorder parameter
- O = output data

Settings

Table 5.1.9.4-1 Settings

| Variable | Actual settings (R) | Group 1 (R, W, P) | Group 2 (R, W, P) | Setting range |
|--|---------------------|-------------------|-------------------|---|
| Set start value of stage $I_{0>}$ | S1 | S41 | S81 | $0.01...0.80 \times I_n$ |
| Operate time or time multiplier k of stage $I_{0>}$ | S2 | S42 | S82 | 0.05...300 s or 0.05...1.00 ¹⁾ |
| Set start value of stage $I_{0>>}$ | S3 ²⁾ | S43 | S83 | $0.05...4.00 \times I_n$ |
| Operate time of stage $I_{0>>}$ | S4 | S44 | S84 | 0.04...300 s |
| Checksum, SGF 1 | S5 | S45 | S85 | 0...255 |
| Checksum, SGF 2 | S6 | S46 | S86 | 0...255 |
| Checksum, SGF 3 | S7 | S47 | S87 | 0...255 |
| Checksum, SGB 1 | S8 | S48 | S88 | 0...255 |
| Checksum, SGR 1 | S9 | S49 | S89 | 0...255 |
| Checksum, SGR 2 | S10 | S50 | S90 | 0...255 |
| Checksum, SGR 3 | S11 | S51 | S91 | 0...255 |
| Checksum, SGR 4 | S12 | S52 | S92 | 0...255 |
| Operate time of CBFP | - | S121 | S121 | 0.10...1.00 s |
| Time setting for disabling new trip indications on the LCD | - | S122 | S122 | 0...999 min |

¹⁾ Values above 1 equal 1.

²⁾ If the protection stage has been set out of operation, the number indicating the currently used value will be displaced by "999" when parameters are read via the SPA bus and by dashes on the LCD.

Recorded data

Parameters V1 and V2 show the number of starts of the protection stages, parameter V3 the stage which has caused the trip and parameter V4 the trip indication code.

Table 5.1.9.4-2 Recorded data: Parameters V1...V4

| Recorded data | Parameter | R/W | Value |
|---|-----------|-----|--|
| Number of starts of stage $I_{0>}$ | V1 | R | 0...999 |
| Number of starts of stage $I_{0>>}$ | V2 | R | 0...999 |
| Stage which caused the trip; the value may also be a combination of two or more of the individual values, e.g. 3 (=1 + 2) | V3 | R | 1= $I_{0>}$ 2= $I_{0>>}$ |
| Trip indication code | V4 | R | 0 = --- 1 = start of stage $I_{0>}$ 2 = trip of stage $I_{0>}$ 3 = start of stage $I_{0>>}$ 4 = trip of stage $I_{0>>}$ 5 = trip of the CBFP unit |

Technical Reference Manual

The last five recorded values can be read with parameters V11...V95. Event n denotes the last recorded value, n-1 the next one, and so forth.

Table 5.1.9.4-3 Recorded data

| Recorded data | Event (R) | | | | | Value |
|--|-----------|-----|-----|-----|-----|---------------|
| | n | n-1 | n-2 | n-3 | n-4 | |
| Earth-fault current, I_0 | V11 | V31 | V51 | V71 | V91 | 0...8 x I_n |
| Start duration, stage $I_0 >$ | V12 | V32 | V52 | V72 | V92 | 0...100% |
| Start duration, stage $I_0 >>$ | V13 | V33 | V53 | V73 | V93 | 0...100-% |
| Time stamp of the registered value, date | V14 | V34 | V54 | V74 | V94 | YY-MM-DD |
| Time stamp of the registered value, time | V15 | V35 | V55 | V75 | V95 | HH.MM; SS.sss |

Disturbance recorder

Table 5.1.9.4-4 Parameters for the disturbance recorder

| Description | Parameter | R/W | Value/Note |
|--|-------------------|------|--|
| Manual triggering | M1 ²⁾ | W | 1 |
| Clear recorder memory | M2 | W | 1 |
| Sampling rate | M15 ³⁾ | R | 800/960 Hz 400/480 Hz 50/60 Hz |
| Station identification/unit number | M18 | R, W | 0...9999 |
| Rated frequency | M19 | R | 50 or 60 Hz |
| Station name | M20 | R, W | Max 16 characters |
| Digital channel texts | M40...44 | R | |
| Analogue channel text | M60 | R | |
| Analogue channel conversion factor and unit, I_0 | M80 ¹⁾ | R, W | Factor 0...65535, unit (A, kA), e.g. 10.0,kA |
| Post-triggering recording length | V240 | R, W | 0...100% |
| Internal trigger signals' checksum | V241 | R, W | 0...15, see table 5.1.9.4-5 |
| Internal trigger signal's edge | V242 | R, W | 0...15, 0 = rising, 1 = falling |
| External trigger signal (BI) | V243 | R, W | 0/1, see table 5.1.9.4-6 |
| External trigger signal's edge | V244 | R, W | 0/1, 0 = rising, 1 = falling |
| Triggering state, clearing and restart | V246 | R, W | R: 0 = recorder not triggered 1 = recorder triggered and recording stored in the memory W: 0 = clear recorder memory 2 = download restart; sets the first information and the time stamp for triggering ready to be read 4 = manual triggering |

¹⁾ The disturbance recorder requires this parameter to be set. The conversion factor is the transformation ratio multiplied by the rated current of the relay. If this parameter has been given the default value 0, dashes will be shown on the LCD instead of the primary values and the recorded data will be redundant.

²⁾ M1 can be used for broadcast triggering by using the unit address 900".

³⁾ Parameters can be written if the recorder has not been triggered.

Table 5.1.9.4-5 Disturbance recorder internal triggering

| Event | Weighting factor | Default value of triggering mask, V241 | Default value of triggering edge, V242 |
|----------------------------------|------------------|--|--|
| Start of stage I ₀ > | 1 | 0 | 0 |
| Trip of stage I ₀ > | 2 | 0 | 0 |
| Start of stage I ₀ >> | 4 | 0 | 0 |
| Trip of stage I ₀ >> | 8 | 1 | 0 |
| Not in use | - | 0 | 0 |
| Not in use | - | 0 | 0 |
| Not in use | - | 0 | 0 |
| Not in use | - | 0 | 0 |
| Checksum | | 8 | 0 |

Table 5.1.9.4-6 Disturbance recorder external triggering

| Event | Weighting factor | Default value of triggering mask, V243 | Default value of triggering edge, V244 |
|---------------------------|------------------|--|--|
| External BI ^{*)} | 1 | 1 | 0 |
| Not in use | - | 0 | 0 |
| Not in use | - | 0 | 0 |
| Not in use | - | 0 | 0 |
| Not in use | - | 0 | 0 |
| Not in use | - | 0 | 0 |
| Not in use | - | 0 | 0 |
| Not in use | - | 0 | 0 |
| Checksum | | 1 | 0 |

^{*)} Note that the value of SGB1/3 has to be 0 (indications, output contacts and memorized values will not be reset by the binary input signal).

Control parameters

Table 5.1.9.4-7 Control parameters

| Description | Parameter | R/W | Value |
|--|-----------|--------|--|
| Unlatching output contacts | V101 | W | 1 = unlatch |
| Clearing registers and unlatching output contacts | V102 | W | 1 = clear and unlatch |
| Rated frequency | V133 | R,W(P) | 50=50 Hz 60=60 Hz |
| Remote control of settings | V150 | R,W | 0 = setting group 1 1 = setting group 2 |
| Event mask for I ₀ > and I ₀ >> | V155 | R,W | 0...255, see "Event codes" |
| Event mask for output contacts' events | V156 | R,W | 0...255, see "Event codes" |
| Event mask for the disturbance recorder and the HMI password | V157 | R,W | 0...7, see "Event codes" |
| Entering the SPA password for settings | V160 | W | 1...999 |

Table 5.1.9.4-7 Control parameters (Continued)

| Description | Parameter | R/W | Value |
|--|-----------|-------|--|
| Changing the SPA password or reinstating the password protection | V161 | W (P) | 1...999 |
| Changing the HMI password | V162 | W | 1...999 |
| Activating the self-supervision | V165 | W | 1 = the self-supervision output contact is activated and the READY indicator LED starts to blink 0 = normal operation |
| LED test for start and trip indicators | V166 | W (P) | 0 = start and trip LEDs off 1 = trip LED on, start LED off 2 = start LED on, trip LED off 3 = start and trip LEDs on |
| Default settings | V167 | W (P) | 2 = restore factory settings |
| Internal fault code | V169 | R | 0...255 |
| Unit address of the relay | V200 | R, W | 1...254 |
| Data transfer rate, kbps | V201 | R, W | 4.8 or 9.6 |
| Rear communication | V202 | W | 1 = rear connector activated |
| Relay serial number | V230 | R | ERxxxxxx |
| CPU serial number | V231 | R | MRxxxxxx |
| Article number | V232 | R | 1MRS091413-BAA |
| Test date | V233 | R | YYYYMMDD |
| Software number | V234 | R | 1MRS118013 |
| Software revision | V235 | R | A...Z |
| Software build number | V236 | R | |
| Date reading and setting (RED 500 format) | V250 | R, W | YY-MM-DD |
| Time reading and setting (RED 500 format) | V251 | R, W | HH.MM; SS.sss |
| Reading of an event register | L | R | Time, channel number and event code |
| Re-reading of an event register | B | R | Time, channel number and event code |
| Type designation of the relay | F | R | REJ 521 |
| Reading of relay state data | C | R | 0 = normal state 1 = the relay has been subject to an automatic reset 2 = overflow of an event register 3 = both events 1 and 2 |
| Resetting of relay state data | C | W | 0 = resetting E 50 and E51 1 = reset only E50 2 = reset only E51 4 = reset all events including E51 except for E50 |
| Time reading and setting | T | R, W | 00.000...59.999 s |
| Date and time reading and setting | D | R, W | YY-MM-DD HH.MM;SS.sss |

Input and output signals

The measured currents and the status of the binary input signal can be read (R) with parameters I1 and I2. When the value of parameter I2 is 1, the binary input will be energized.

Table 5.1.9.4-8 Inputs

| Information | Parameters (R) | Value |
|------------------------------|----------------|--------------------------|
| Measured earth-fault current | I1 | 0...8.0 x I _n |
| Binary input signal | I2 | 0 or 1 |

Each protection stage has its internal output signal. These signals can be read (R) with parameters O1...O4. The state of the output contacts can be read (R) or changed (W) with parameters O5...O8. Functions indicated by parameters O1...O8 are recorded and can be read with parameters O21...O28.

Table 5.1.9.4-9 Output signals

| Status of the protection stages | State of stage (R) | Recorded functions (R) | Value |
|----------------------------------|--------------------|------------------------|--------|
| Start of stage I ₀ > | O1 | O21 | 0 or 1 |
| Trip of stage I ₀ > | O2 | O22 | 0 or 1 |
| Start of stage I ₀ >> | O3 | O23 | 0 or 1 |
| Trip of stage I ₀ >> | O4 | O24 | 0 or 1 |

Table 5.1.9.4-10 Outputs

| Operation of output contacts | State of output (R,W,P) | Recorded functions (R) | Value |
|--|-------------------------|------------------------|--------|
| Output PO1 | O5 | O25 | 0 or 1 |
| Output PO2 | O6 | O26 | 0 or 1 |
| Output SO1 | O7 | O27 | 0 or 1 |
| Output SO2 | O8 | O28 | 0 or 1 |
| Enabling output contacts PO1, PO2, SO1 and SO2 | O41 | - | 0 or 1 |

5.1.10.

Self-supervision (IRF) system

The REJ 521 is provided with an extensive self-supervision system which continuously supervises the software and the electronics of the relay. It handles run-time fault situations and informs the user about an existing fault via a LED on the HMI and a text message on the LCD.

When a fault is detected, the relay will first try to eliminate it by restarting. Only after the fault is found to be permanent, the green READY indicator LED will start to blink and the self-supervision output contact will be activated. All other output contacts are blocked during an internal fault. Further, a fault indication message will appear on the LCD.

Fault indications have the highest priority on the HMI. None of the other HMI indications can override the IRF indication. As long as the READY indicator LED is blinking, the fault indication can not be cleared. In case an internal fault

disappears, the READY indicator LED will stop blinking and the IRF relay will be returned to the normal service state, but the fault indication message will remain on the LCD.

The IRF code is the code of the last internal fault detected by the self-supervision system and describes the type of fault. When a fault appears, the code is to be recorded and given to an authorised repair shop when overhaul is ordered. For fault codes, refer to the Operator's Manual.

5.1.11. **Relay parameterization**

Local parameterization

The parameters of the relay can be set either locally via the HMI or externally via serial communication with the Relay Setting Tool. When the parameters are set locally, the setting parameters can be chosen via the hierarchical menu structure. The desired language can be selected for parameter descriptions. Refer to the Operator's Manual for further information.

External parameterization

The Relay Setting Tool is used for parameterizing the relay units. Adjusting the parameter values using the Relay Setting Tool is done off-line, after which the parameters can be downloaded to the relay via a communication port.

5.2. **Design description**

5.2.1. **Input/output connections**

All external circuits are connected to the terminals on the rear panel of the relay. Terminals X1.1-__ are dimensioned for one 0.5...6.0 mm² wire or for two max 2.5 mm² wires and terminals X2.1-__ for one 0.08...2.5 mm² wire or for two max 1.5 mm² wires.

The energizing current of the earth-fault unit is connected to terminals X1.1/1-2 when the rated current is $I_n = 1.0$ A, and to terminals X1.1/1-3 when it is $I_n = 0.2$ A.

The binary input X2.1/17-18 can be used to generate an external blocking signal, to unlatch the output contacts or for remote control of relay settings. The requested function is selected in SGB. The binary input can also be used as a trigger signal for the disturbance recorder; this function is selected with SPA parameter V243.

The auxiliary voltage of the relay is connected to terminals X2.1/1-2. At DC supply, the positive lead is connected to terminal X2.1/1. For details, refer to the description of the auxiliary voltage. The permitted auxiliary voltage range of the relay is marked on the front panel of the relay.

Output contacts PO1 and PO2 are heavy-duty trip contacts, capable of controlling most circuit breakers. The trip signals from both protection stages are routed to the output contacts with switches 1 and 2 of SGR1...SGR4. On delivery from the factory, the trip signals from both protection stages are routed to both PO1 and PO2.

Technical Reference Manual

Output contacts SO1 and SO2 can be used for signalling on start and tripping of the relay. The signals to be routed to output contacts SO1 and SO2 are selected with switches 3 and 4 of SGR1...SGR4. On delivery from the factory, the start signals from both protection stages are routed to both SO1 and SO2.

Output contact IRF functions as an output contact for the self-supervision system of the protection relay. The IRF relay is energized under normal operating conditions and contact gap X2.1/13-15 is closed. When a fault is detected by the self-supervision system or the auxiliary voltage is disconnected, the output contact will drop off and contact X2.1/13-14 will close.

The following picture presents a rear view of the REJ 521, showing three connecting sockets: one for measuring transformers, one for power supply and one for serial communication.

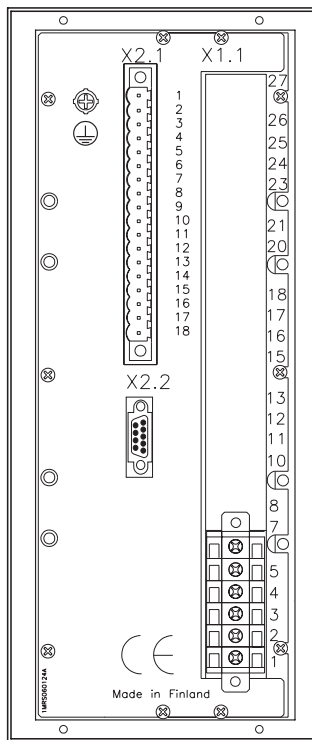

A051301

Fig. 5.2.1.-1 Rear view of the relay

Table 5.2.1-1 Inputs for earth-fault current

| Terminal | Function | |
|----------|----------------------|--------------------|
| | REJ 521B 413BAA | REJ 521B 416BAA |
| X1.1-1 | Common | Common |
| X1.1-2 | I ₀ 1 A | I ₀ 5 A |
| X1.1-3 | I ₀ 0.2 A | I ₀ 1 A |

Table 5.2.1-2 Auxiliary supply voltage

| Terminal | Function |
|----------|----------|
| X2.1-1 | Input+ |
| X2.1-2 | Input- |

Table 5.2.1-3 Output contacts

| Terminal | Function |
|-------------------------------|-----------------------------------|
| X2.1-3 X2.1-4 | PO1, closing contact |
| X2.1-5 X2.1-6 | PO2, closing contact |
| X2.1-7 X2.1-8 X2.1-9 | SO1, common SO1, NC SO1, NO |
| X2.1-10 X2.1-11 X2.1-12 | SO2, common SO2, NC SO2, NO |

Table 5.2.1-4 IRF contact

| Terminal | Function |
|----------|---|
| X2.1-13 | Internal relay fault, common |
| X2.1-14 | Closed; IRF, or U_{aux} disconnected |
| X2.1-15 | Closed; no IRF, and U_{aux} connected |

Table 5.2.1-5 Binary input BI

| Terminal | Function |
|----------|----------|
| X2.1-17 | Input+ |
| X2.1-18 | Input- |

5.2.2.

Serial communication connections

The REJ 521 is interfaced with a fibre-optic bus by means of the bus connection module RER 103 via the D9S-type connector X2 located on the rear panel of the device. The terminals of the fibre-optic cables are connected to the counter terminals Rx (Receiver) and Tx (Transmitter) of the bus connection module. The fibre-optic cables are linked from one protection relay to another and to the substation level communication unit, e.g. SRIO 1000M and the RER 125.

The optical PC-connection on the front panel of the relay is used to connect the relay to a fibre-optic SPA bus via opto-cable 1MKC950001-2.

Table 5.2.2-1 RS-485 connector X2 for the RER 103

| Terminal | Function |
|----------|---|
| X.2.2-1 | Data A (data signal +) |
| X.2.2-2 | Data B (data signal -) |
| X.2.2-3 | RTS A (request to send +) |
| X.2.2-4 | RTS B (request to send -) |
| X.2.2-5 | COL A (2.8 V on relay) |
| X.2.2-6 | COL B (2.2 V on relay) |
| X.2.2-7 | GND |
| X.2.2-8 | NC |
| X.2.2-9 | +5 V DC, auxiliary voltage (max 200 mA) |

5.2.3.

Technical data

Table 5.2.3-1 Dimensions ¹

| |
|---|
| Width, frame 111.4 mm, box 94 mm |
| Height, frame 265.9 mm (6U), box 249.8 mm |
| Depth 235 mm, (245.1 mm with a protective rear cover, available as an option) |
| Enclosure size 1/4 (x 19") |
| Weight of the relay ~2.8 kg |

¹⁾ For dimension drawings, refer to the Installation Manual.

Table 5.2.3-2 Power supply

| | |
|---|--|
| U _{aux} rated | Ur =110/120/220/240 V AC Ur =48/60/110/125/220 V DC |
| U _{aux} variation | 80...265 V AC 38...265 V DC |
| Relay power start-up time, typical | 300 ms |
| Burden of auxiliary voltage under quiescent/operating condition | ~ 5 W/~10 W |
| Ripple in DC auxiliary voltage | Max 12% of the DC value |
| Interruption time in the auxiliary DC voltage without resetting the relay | < 30 ms at 48 V DC < 100 ms at 110 V DC < 500 ms at 220 V DC |

Table 5.2.3-3 Energizing inputs

| | | | |
|-------------------------------|----------------|----------|---------|
| Rated frequency | 50/60 Hz ±5 Hz | | |
| Rated current, I _n | 0.2 A | 1 A | 5 A |
| Thermal withstand capability | | | |
| • continuously | 1.5 A | 4 A | 20 A |
| • for 1 s | 20 A | 100 A | 500 A |
| Dynamic current withstand | | | |
| • half-wave value | 50 A | 250 A | 1250 A |
| Input impedance | < 750 mΩ | < 100 mΩ | < 20 mΩ |

Table 5.2.3-4 Measuring range

| | |
|--|------------------------|
| Earth-fault current as a multiple of the rated current of the energizing input | 0...8 x I _n |
|--|------------------------|

Table 5.2.3-5 Binary input

| | |
|-------------------|-----------------------|
| Operating range | 18...265 V DC |
| Rated voltage | 24/48/60/110/220 V DC |
| Current drain | ~ 2...25 mA |
| Power consumption | < 0.8 W |

Table 5.2.3-6 Signal outputs (SO1, SO2) and self-supervision (IRF) output

| | |
|--|----------------------|
| Rated voltage | 250 V AC/DC |
| Continuous carry | 5 A |
| Make and carry for 3.0 s | 8 A |
| Make and carry for 0.5 s | 10 A |
| Breaking capacity when the control circuit time-constant L/R < 40 ms, at 48/110/220 V DC | 1 A/0.25 A/0.15 A |
| Minimum contact load | 100 mA at 24 V AC/DC |

Table 5.2.3-7 Power outputs (PO1, PO2)

| | |
|--|----------------------|
| Continuous carry | 5 A |
| Rated voltage | 250 V AC/DC |
| Make and carry for 3.0 s | 15 A |
| Make and carry for 0.5 s | 30 A |
| Breaking capacity when the control circuit time-constant L/R < 40 ms, at 48/110/220 V DC | 5 A/3 A/1 A |
| Minimum contact load | 100 mA at 24 V AC/DC |

Table 5.2.3-8 Enclosure class

| | |
|---|-----------------------|
| Front side | IP 54 (flush-mounted) |
| Rear side, connection terminals | IP20 |
| Note! A rear protective cover (accessory part) can be used to protect and shield the rear of the case. | |

Table 5.2.3-9 Environmental tests

| | |
|---|--|
| Specified service temperature range | -10...+55 °C |
| Transport and storage temperature range | -40...+70 °C according to the IEC 60068-2-48 |
| Dry heat test | According to the IEC 60068-2-2 |
| Dry cold test | According to the IEC 60068-2-1 |
| Damp heat test, cyclic | According to the IEC 60068-2-30 |

Table 5.2.3-10 Electromagnetic compatibility tests

| | |
|--|---|
| EMC immunity test level requirements consider the demands in the generic standard EN 50082-2 | |
| 1 MHz burst disturbance test, class III • Common mode • Differential mode | According to the IEC 60255-22-1 2.5 kV 1.0 kV |
| Electrostatic discharge test, class III • For contact discharge • For air discharge | According to the IEC 61000-4-2 and IEC 60255-22-2 6 kV 8 kV |
| Radio frequency interference tests • Conducted, common mode • Radiated, amplitude-modulated • Radiated, pulse-modulated • Radiated, test with a portable transmitter | According to the IEC 61000-4-6 and IEC 60255-22-6 (2000) 10 V (rms), f=150 kHz...80 MHz According to the IEC 61000-4-3 and IEC 60255-22-3 (2000) 10 V/m (rms), f=80...1000 MHz According to the ENV 50204 and IEC 60255-22-3 (2000) 10 V/m, f=900 MHz According to the IEC 60255-22-3 (1989), method C; f=77.2 MHz, P=6 W; f= 72.25 MHz, P=5W |
| Fast transient disturbance tests • Binary input • Other terminals | According to the IEC 60255-22-4 and IEC 61000-4-4 2 kV 4 kV |

Table 5.2.3-10 Electromagnetic compatibility tests (Continued)

| | |
|---|--|
| Surge immunity test • Power supply • I/O ports | According to the IEC 61000-4-5 4 kV, line-to-earth 2 kV, line-to-line 2 kV, line-to-earth 1 kV, line-to-line |
| Power frequency (50 Hz) magnetic field | According to the IEC 61000-4-8 100 A/m continuous |
| Voltage dips and short interruptions | According to the IEC 61000-4-11 30%/10 ms 60%/100 ms > 95%/5000 ms |
| Electromagnetic emission tests • Conducted, RF-emission (Mains terminal) • Radiated RF-emission | According to the EN 55011 and EN 50081-2 EN 55011, class A, IEC 60255-25 EN 55011, class A, IEC 60255-25 |
| CE approval: | Complies with the EMC directive 89/336/EEC and the LV directive 73/23/EEC |

Table 5.2.3-11 Standard tests

| | |
|--|---|
| Insulation tests | |
| Dielectric tests • Test voltage | According to the IEC 60255-5 2 kV, 50 Hz, 1 min |
| Impulse voltage test • Test voltage | According to the IEC 60255-5 5 kV, unipolar impulses, waveform 1.2/50 μ s, source energy 0.5 J |
| Insulation resistance measurements • Isolation resistance | According to the IEC 60255-5 > 100 M Ω , 500 V DC |
| Mechanical tests | |
| Vibration tests (sinusoidal) | According to the IEC 60255-21-1, class I |
| Shock and bump test | According to the IEC 60255-21-2, class I |

Table 5.2.3-12 Data communication

| |
|--|
| Rear interface, connector X2.2 • RS-485 connection for the fibre-optic interface module RER 103 • SPA-bus or IEC 60870-5-103 protocol • 4.8 or 9.6 kbps |
| Front interface • Optical RS-232 connection for the opto-cable • SPA-bus protocol • 4.8 or 9.6 kbps |

Auxiliary voltage

The REJ 521 requires a secured auxiliary voltage supply to operate. The internal power supply of the relay forms the voltages required by the relay electronics. The power supply is a galvanically isolated (flyback-type) DC/DC converter. When the auxiliary voltage is connected, the READY indicator LED on the front panel will be on. For detailed information on power supply, refer to table 5.2.3-2.

The primary side of the power supply is protected with a fuse located on the PCB of the relay. The fuse size is 3.15 A (slow).

6. Ordering Information

| | |
|--------------------------------------|----------------------|
| Order number | REJ521A 413BAA |
| Article number | 1MRS091413-BAA |
| Protective cover for rear connectors | 1MRS060132 |
| Flush mounting kit | 1MRS050209 |
| Semi-flush mounting kit | 1MRS050253 |
| Wall mounting kit | 1MRS050240 |
| Side-by-side mounting kit | 1MRS050241 |
| 19" Rack mounting kit | 1MRS050257 |
| Optic bus connection module | 1MRS090701 (RER 103) |
| Opto-cable | 1MKC950001-2 |

7.**Abbreviations**

| | |
|----------|--|
| BI | Binary input |
| CBFP | Circuit-breaker failure protection |
| CPU | Central processing unit |
| CT | Current transformer |
| IDMT | Inverse definite minimum time characteristic |
| IEC_103 | Standard IEC 60870-5-103 |
| IRF | Internal relay fault |
| LCD | Liquid Crystal Display |
| LED | Light-emitting diode |
| LSG | LON/SPA Gateway, SPA-ZC 102 |
| HMI | Human-Machine Interface |
| PCB | Printed Circuit Board |
| PO1, PO2 | Power outputs |
| SGB | Switchgroup for binary input |
| SGF | Switchgroups for functions |
| SGR | Switchgroups for output contacts |
| SO1, SO2 | Signal outputs |

8. Check Lists

Table 8.-1 Setting group 1

| Variable | Group 1 (R, W, P) | Setting range | Default setting | Customer's setting |
|---|----------------------|--------------------------|-------------------|--------------------|
| Set start value of stage $I_{0>}$ | S41 | $0.01...0.80 \times I_n$ | $0.01 \times I_n$ | |
| Operate time or time multiplier k of stage $I_{0>}$ | S42 | 0.05...300 s | 0.05 s/0.05 | |
| Set start value of stage $I_{0>>}$ | S43 | $0.05...4.00 \times I_n$ | $0.05 \times I_n$ | |
| Operate time of stage $I_{0>>}$ | S44 | 0.04...300 s | 0.04 s | |
| Checksum, SGF 1 | S45 | 0...255 | 0 | |
| Checksum, SGF 2 | S46 | 0...255 | 0 | |
| Checksum, SGF 3 | S47 | 0...255 | 0 | |
| Checksum, SGB 1 | S48 | 0...255 | 0 | |
| Checksum, SGR 1 | S49 | 0...255 | 12 | |
| Checksum, SGR 2 | S50 | 0...255 | 3 | |
| Checksum, SGR 3 | S51 | 0...255 | 12 | |
| Checksum, SGR 4 | S52 | 0...255 | 3 | |

Table 8.-2 Setting group 2

| Variable | Group 2 (R, W, P) | Setting range | Default setting | Customer's setting |
|---|----------------------|--------------------------|-------------------|--------------------|
| Set start value of stage $I_{0>}$ | S81 | $0.01...0.80 \times I_n$ | $0.01 \times I_n$ | |
| Operate time or time multiplier k of stage $I_{0>}$ | S82 | 0.05...300 s | 0.05 s/0.05 | |
| Set start value of stage $I_{0>>}$ | S83 | $0.05...4.00 \times I_n$ | $0.05 \times I_n$ | |
| Operate time of stage $I_{0>>}$ | S84 | 0.04...300 s | 0.04 s | |
| Checksum, SGF 1 | S85 | 0...255 | 0 | |
| Checksum, SGF 2 | S86 | 0...255 | 0 | |
| Checksum, SGF 3 | S87 | 0...255 | 0 | |
| Checksum, SGB 1 | S88 | 0...255 | 0 | |
| Checksum, SGR 1 | S89 | 0...255 | 12 | |
| Checksum, SGR 2 | S90 | 0...255 | 3 | |
| Checksum, SGR 3 | S91 | 0...255 | 12 | |
| Checksum, SGR 4 | S92 | 0...255 | 3 | |

Table 8.-3 Control parameters

| Variable | Parameter | Setting range | Default setting | Customer's setting |
|--|-----------|---------------|-----------------|--------------------|
| Rated frequency | V133 | 50/60 | 50 | |
| Remote control of settings | V150 | 0/1 | 0 | |
| Non-volatile memory settings | V152 | 0...31 | 31 | |
| Event mask for $I_0>$ and $I_0>>$ | V155 | 0...255 | 85 | |
| Event mask for output contacts' events | V156 | 0...255 | 3 | |
| Event mask for the disturbance recorder and the HMI password | V157 | 0...7 | 1 | |
| Unit address of the relay | V200 | 1...254 | 1 | |
| Data transfer rate | V201 | 4.8 or 9.6 | 9.6 | |
| Operate time of the CBFP | S121 | 0.10...1.00 s | 0.10 s | |
| Time setting for disabling new trip indications on the LCD | S122 | 0...999 min | 60 | |

Table 8.-4 Parameters for the disturbance recorder

| Information | Parameter | Setting range | Default setting | Customer's setting |
|--|-----------|--------------------------------|-----------------|--------------------|
| Post-triggering recording length in percent | V240 | 0...100% | 50% | |
| Internal trigger signals' checksum | V241 | 0...15 | 8 | |
| Internal trigger signal's edge | V242 | 0...15 | 0 | |
| External trigger signal (BI) | V243 | 0/1 | 1 | |
| External trigger signal's edge | V244 | 0/1 | 0 | |
| Station identification/unit number | M18 | 0...9999 | 0000 | |
| Station name | M20 | Max 16 characters | - ABB - | |
| Analogue channel conversion factor and unit, I_0 | M80 | Factor 0...65535, unit (A, kA) | 00000, A | |

9. Service

When the protection relay is used under the conditions specified in Section 5.2.3. "Technical data", it is practically maintenance-free. The protection relay electronics include no parts or components subject to abnormal physical or electrical wear under normal operating conditions.

If the relay fails in operation or if the operating values considerably differ from those mentioned in the protection relay specifications, the relay should be overhauled. All repairs are to be taken by the manufacturer. Please contact the manufacturer or its nearest representative for further information about checking, overhaul and recalibration of the relay.



To achieve the best possible operation accuracy, all parts of the protection relay have been calibrated together. In the event of malfunction, please consult your relay supplier.

If the protection relay is sent to the manufacturer, it has to be carefully packed to prevent further damage to the device.

10.**Index****A**

| | |
|-------------------------|--------|
| Application | 11 |
| Auxiliary voltage | 51, 54 |

B

| | |
|-------------------------|----|
| Binary input test | 33 |
| Block diagram | 16 |

C

| | |
|------------------------------|--------|
| CBFP | 14 |
| Check lists | 59 |
| Checksum calculation | 27 |
| Communication ports | 36 |
| Communication protocol | 37 |
| Comtrade | 35 |
| Configuration | 11, 15 |
| Connection diagram | 12 |
| Control parameters | 45, 60 |
| Counter | 37 |

D

| | |
|---------------------------------|------------|
| Design description | 48 |
| Disturbance recorder | 14, 33, 44 |
| Disturbance recorder data | 33 |

E

| | |
|---------------------------------|--------|
| Earth-fault unit | 16 |
| Environmental conditions | 11 |
| Event code | 35, 40 |
| External parameterization | 48 |

F

| | |
|---------------------|--------|
| Fault code | 15, 48 |
| Features | 9 |
| Function test | 33 |

H

| | |
|-----------|--------|
| HMI | 14, 26 |
|-----------|--------|

Technical Reference Manual

| | |
|--------------------------------|------------|
| I | |
| IEC 60255 standard | 17 |
| IEC 60870-5-103 | 37 |
| Indication messages | 32, 47 |
| Input/output connections | 48 |
| Input/output signals | 47 |
| Inputs | 13 |
| Internal relay fault | 14, 47 |
| L | |
| Latching feature | 27 |
| LCD | 14, 47 |
| LED | 14, 32, 47 |
| LED test | 33 |
| Local parameterization | 48 |
| LON bus | 36 |
| M | |
| Master reset | 35 |
| Measurements | 15 |
| N | |
| New trip indication | 31 |
| Non-volatile memory | 14, 31 |
| O | |
| Ordering information | 55 |
| P | |
| Parameterization | 48 |
| Password | 14, 42 |
| Power outputs (PO1, PO2) | 13 |
| Product functions | 13 |
| R | |
| RD-type characteristic | 19 |
| Recorded data | 35, 43 |
| Requirements | 11 |
| RI-type characteristic | 18 |

Technical Reference Manual

S

| | |
|--------------------------------------|--------|
| Self-supervision | 14, 47 |
| Serial communication | 36, 50 |
| Setting groups | 26, 59 |
| Settings | 26 |
| SGB1 | 29 |
| SGF1...SGF3 | 27 |
| SGR1...SGR4 | 30 |
| Signal diagram | 15 |
| Signal outputs (SO1, SO2) | 13 |
| SPA bus communication protocol | 36 |
| Switchgroups | 27 |

T

| | |
|--|----|
| Technical data | 51 |
| Technical data on protection functions | 32 |
| Time/current characteristics | 17 |

W

| | |
|------------------------|----|
| Weighting factor | 27 |
|------------------------|----|



ABB Oy

Distribution Automation

P.O. Box 699

FI-65101 Vaasa

FINLAND

Tel. +358 10 22 11

Fax. +358 10 224 1094

www.abb.com/substationautomation