

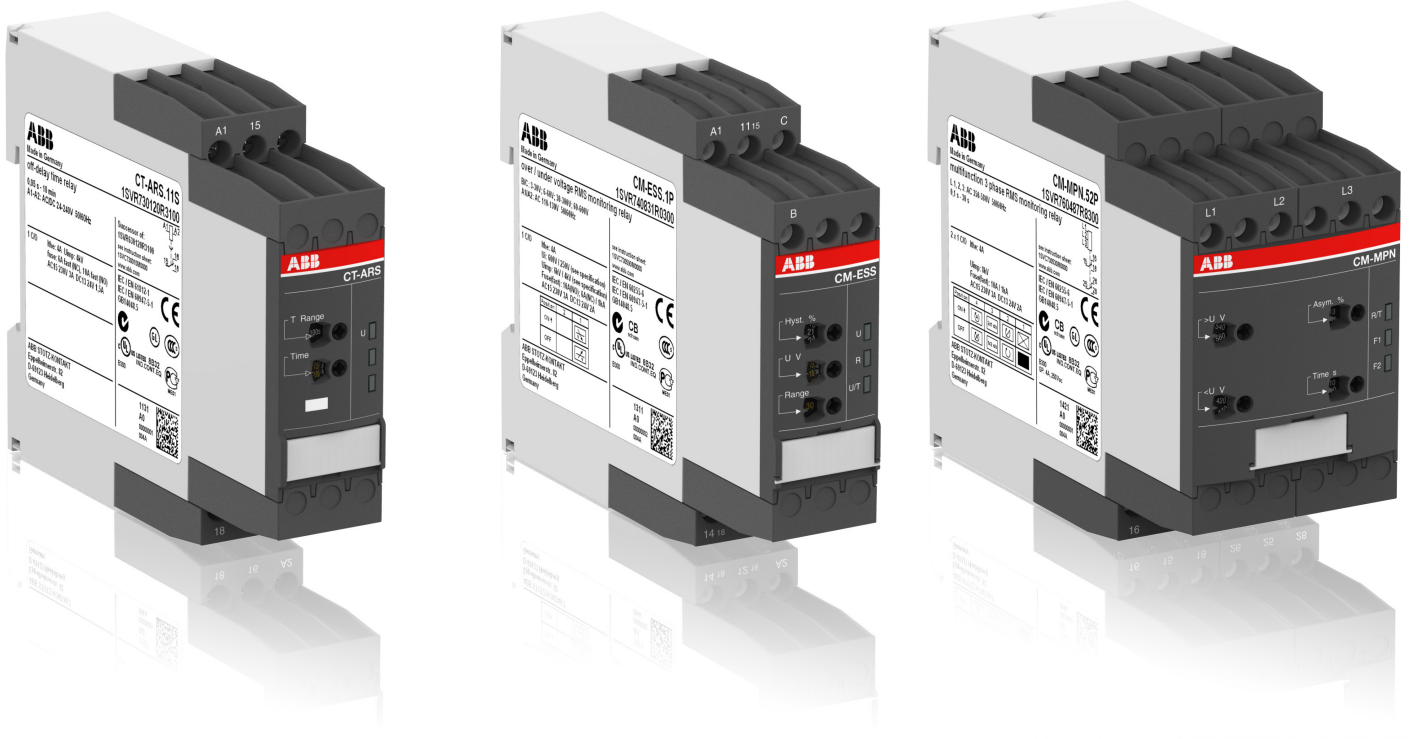

New S and N range housing
Easy Connect Technology & Double-
Chamber Cage Connection Terminals

The new S and N range housing Innovative connection technologies



The new housing provides two different connection possibilities:
Double-Chamber Cage Connection Terminals and Push-in Terminals.

General facts

ABB invented a totally new housing for all time relays and measuring & monitoring relays in S and N range with innovative connection technologies. In form and design the new housing meets both: ABB's latest design standards and EPR's requirements on a sophisticated product. All devices are available with both innovative Push-in Terminals and State of the Art Double-Chamber Cage Connection Terminals.

Easy Connect Technology

Thanks to the innovative new Push-in Terminals, the devices with Easy Connect Technology can be wired much more quickly and easily – without the need of tools. For example, rigid or flexible wires with wire-end ferrules can be connected without any need of a tool. Even flexible wires without ferrules can be directly connected, here the cage must be opened with a screwdriver before. To release the wires the cages have to be opened with a tool.

The Push-in Terminal is suitable for the following wire sizes: rigid or fine-strand with wire-end ferrule, 1 x 0.5...1.5 mm² or 2 x 0.5...1.5 mm² / 1 x 20...16 AWG or 2 x 20...16 AWG.

These Push-in Terminals are completely secure, thus ensuring that the equipment is gas-tight and the perfect solution for vibrating environment.

Double-Chamber Cage Connection Terminals

The screw terminals can be connected with two wires with different wire diameters up to 2,5 mm². According to IEC/EN 60947-1 two rigid or fine-strand wires with ferrules up to 2,5 mm² (AWG14) can be used.

Flexibility

Both solutions, Double-Chamber Cage Connection Terminals and Push-in Terminals, have exactly the same design and size. Both versions can thus be interchanged at any time or positioned alongside each other in a switchboard. With this new housing ABB offers the world wide first complete range of industrial products with Push-in Terminals.

The new S and N range housing

Innovative connection technologies

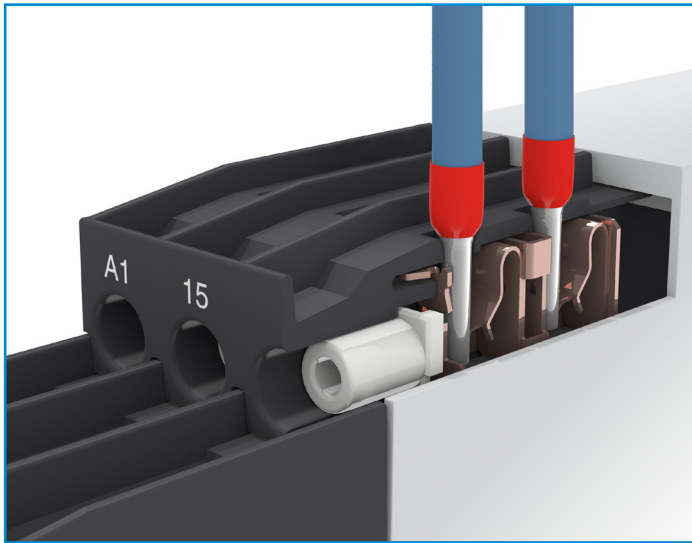

Maintenance free Easy Connect Technology with push-in terminals

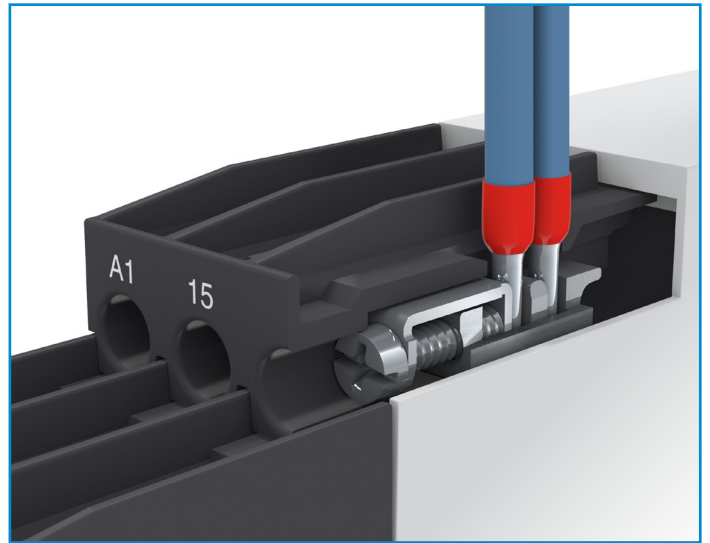

Approved screw connection technology with double-chamber cage connection terminals

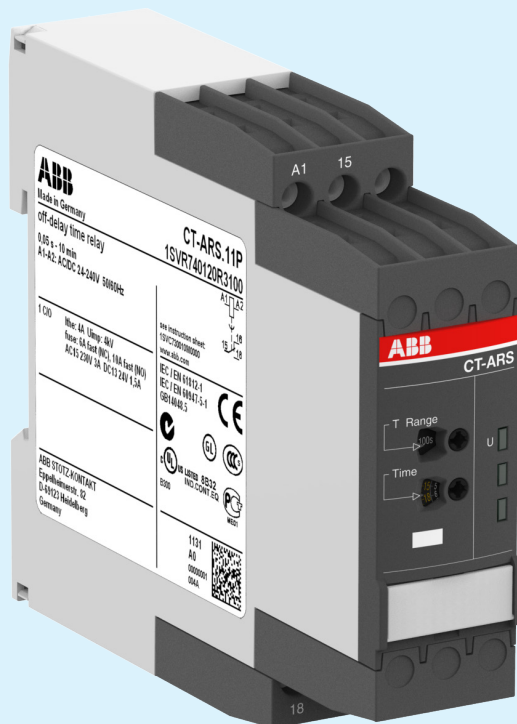

The advantages at a glance

- Push-in Terminals or Double-Chamber Cage Connection Terminals in 22.5 or 45 mm industrial housing
- Designed for worldwide use and to meet international standards for voltages up to 690 V according to UL
- Equipped with max. 12 x 2 double chamber terminals
- Available with a sealable transparent cover
- Integrated marker label
- DIP switches hidden under the marker label for extended functionality
- Complete setup via front face
- Direct reading scales and clear, extended marking
- 1 or 2 change-over output contacts
- Configurable output contacts: 1 x 2 or 2 x 1 c/o contact depending on the functionality and number of thresholds
- Dials protected against overtightening
- DIN rail snap-on housing

Contact us

ABB STOTZ-KONTAKT GmbH

<http://www.abb.com/lowvoltage>

- > Control Products
- > Electronic Relays and Controls
- > Time Relays
- > Single Phase Monitors
- > Three Phase Monitors
- > Insulation Monitors
- > Temperature Monitors

www.abb.com/contacts

Note:

We reserve the right to make technical changes or modify the contents of this document without prior notice. With regard to purchase orders, the agreed particulars shall prevail. ABB AG does not accept any responsibility whatsoever for potential errors or possible lack of information in this document.

We reserve all rights to this document and the subject matter and illustrations contained therein. Any reproduction, disclosure to third parties or utilisation of its contents – in whole or in part – is forbidden without prior written consent from ABB AG.

Copyright© 2013 ABB
All rights reserved