

Effective: March 1972
Supersedes I.L. 41-138.1

Type KH-1 Directional Relay

(|) Denotes Change Since Previous Issue



Before putting relays into service, remove all blocking which may have been inserted for the purpose of securing the parts during shipment, make sure that all moving parts operate freely, inspect the contacts to see that they are clean and close properly, and operate the relay to check the settings and electrical connections.

1.0 APPLICATION

The KH-1 relay is used to supervise breaker closing to insure that power flows from the source to the load bus after closing. The current coil is connected to measure phasing voltage while the potential coil measures bus voltage. These react to close the contacts when the source voltage leads the bus voltage. It may also be used as an underpower or overpower relay by connecting the current circuit to phase 1 and the potential circuit to phase 1 and phase 3 voltage as shown in the external schematic drawings.

2.0 CONSTRUCTION AND OPERATION

The type KH-1 consists of a cylinder directional unit (D).

2.1 DIRECTIONAL UNIT (D)

The directional unit is a product induction cylinder type unit operating on the interaction between the polarizing circuit flux and the operating circuit flux.

Mechanically, the directional overcurrent unit is composed of four basic components: A die-cast alumi-

num frame, an electromagnet, a moving element assembly, and a molded bridge.

The frame serves as the mounting structure for the magnetic core. The magnetic core which houses the lower pin bearing is secured to the frame by a locking nut. The bearing can be replaced, if necessary, without having to remove the magnetic core from the frame.

The electromagnet has two series-connected polarizing coils mounted diametrically opposite one another; two series-connected operating coils mounted diametrically opposite one another: two magnetic adjusting plugs: upper and lower adjusting plus clips, and two locating pins. The locating pins are used to accurately position the lower pin bearing, which is threaded into the bridge. The electromagnet is secured to the frame by four mounting screws.

The moving element assembly consists of a spiral spring, contact carrying member, and an aluminum cylinder assembled to a molded hub which holds the shaft. The shaft has removable top and bottom jewel bearings. The shaft rides between the bottom pin bearing with the cylinder rotating in an air gap formed by the electromagnet and the magnetic core.

The bridge is secured to the electromagnet and frame by two mounting screws. In addition to holding the upper pin bearing, the bridge is used for mounting the adjustable stationary contact housing. The stationary contact housing is held in position by a spring-type clamp. The spring adjuster is located on the underside of the bridge and is attached to the moving contact arm by a spiral spring. The spring adjuster is also held in place by a spring-type clamp.

All possible contingencies which may arise during installation, operation or maintenance, and all details and variations of this equipment do not purport to be covered by these instructions. If further information is desired by purchaser regarding this particular installation, operation or maintenance of this equipment, the local ABB Inc. representative should be contacted.

With the contacts closed, the electrical connection is made through the stationary contact housing clamp, to the moving contact, through the spiral spring out to the spring adjuster clamp.

The pickup is changed by rotating the spring adjuster connected to the spiral spring.

2.2 INDICATING CONTACTOR SWITCH UNIT (ICS)

The indicating contactor switch is a small dc operated clapper type device. A magnetic armature, to which leaf-spring mounted contacts are attached, is attracted to the magnetic core upon energization of the switch. When the switch closes, the moving contacts bridge two stationary contacts, completing the trip circuit. Also during this operation two fingers on the armature deflect a spring located on the front of the switch, which allows the operation indicator target to drop. The target is reset from the outside of the case by a push-rod located at the bottom of the cover.

The front spring, in addition to holding the target, provides restraint for the armature and thus controls the pickup value of the switch.

3.0 CHARACTERISTICS

The KH-1 is an instantaneous directional induction cylinder unit. It is designed for potential polarization and has its maximum torque when the current leads the voltage by approximately 30°. At rated voltage the pickup at maximum torque is .020 amperes.

3.1 TRIP CIRCUIT

The main contacts will safely close 30 amperes at 250 volts dc and the seal-in contacts of the indicating contactor switch will safely carry this current long enough to trip a circuit breaker.

The indicating instantaneous trip contacts will safely close 30 amperes at 250 volts dc, and will carry this current long enough to trip a breaker.

The indicating contactor switch has two taps that provide a pickup setting of 0.2 or 2 amperes. To change taps requires connecting of lead located in front of the tap block to the desired setting by means of a screw connection.

A 1.0 ampere ICS is also available.

3.2 TRIP CIRCUIT CONSTANTS

Indicating Contactor Switch –

0.2 amp tap - - - - -6.5 ohms dc resistance
 2.0 amp tap - - - - -0.15 ohms dc resistance
 1.0 amp rating - - - - -0.1 ohms dc resistance

3.3 DIRECTIONAL UNIT CONTACTS

The moving contact assembly has been factory adjusted for low contact bounce performance and should not be changed.

The set screw in each stationary contact has been shop adjusted for optimum follow and this adjustment should not be disturbed.

4.0 SETTINGS

The only setting required is the pickup current setting which is made by varying the tension of the assembly. With the relay connected to rated voltage apply the desired pickup current at the maximum torque angle (30° current leading). The spring tension can be varied by placing a screwdriver or similar tool into one of the notches located on the periphery by the spring adjuster and rotating it.

4.1 INDICATING CONTACTOR SWITCH (ICS)

The only setting required on the ICS unit is the selection of the 0.2 to 2.0 ampere tap setting. This selection is made by connecting the lead located in front of the tap block to the desired setting by means of the connecting screw.

5.0 INSTALLATION

The relays should be mounted on switchboard panels or their equivalent in a location free from dirt, moisture, excessive vibration, and heat. Mount the relay vertically by means of the four mounting holes on the flange for semi-flush mounting or by means of the rear mounting studs for projection mounting. Either a mounting stud or the mounting screws may be made directly to the terminals by means of screws for steel panel mounting or the terminal studs furnished with the relay for thick panel mounting. The terminal studs may be easily removed or inserted by locking two nuts on the stud and then turning the proper nut with a wrench.

For detailed information, refer to Instruction Leaflet 41-076.

6.0 ADJUSTMENTS AND MAINTENANCE

The proper adjustments to insure correct operation of this relay have been made at the factory. Upon receipt of the relay, no customer adjustments, other than those covered under "SETTINGS", should be required.

6.1 ACCEPTANCE CHECK

The following check is recommended to insure that the relay is in proper working order:

1. **Contact Gap** – The contact gap should be approximately .025".
2. **Sensitivity** – With rated voltage applied to the relay the contact should close at .02 amperes $\pm 10\%$ with the current leading 30° . The internal schematic should be consulted for the proper polarity.
3. **Indicating Contactor Switch (ICS)** – Close the main relay contacts and pass sufficient dc current through the trip circuit to close the contacts of the ICS. This value of current should not be greater than the particular ICS tap setting being used. The indicator target should drop freely.

The contact gap should be approximately .047" between the bridging moving contact and the adjustable stationary contacts. The bridging moving contact should touch both stationary contacts simultaneously.

6.2 ROUTINE MAINTENANCE

All relays should be inspected periodically and the operation should be checked at least once every year or at such other time intervals as may be dictated by experience to be suitable to the particular application.

All contacts should be periodically cleaned. A contact burnisher S#182A836H01 is recommended for this purpose. The use of abrasive material for cleaning contacts is not recommended because of the danger of embedding small particles in the face of the soft silver and thus impairing the contact.

6.3 CALIBRATION

Use the following procedure for calibrating the relay if the relay has been taken apart for repairs of the adjustments have been disturbed. This procedure should not be used unless it is apparent that the relay is not in proper working order. (See "ACCEPTANCE CHECK").

1. The upper pin bearing should be screwed down until there is approximately .025" clearance between it and the top of shaft bearing. The upper pin bearing should then be securely locked in position with the lock nut. The lower bearing position is fixed and cannot be adjusted.
2. The contact gap adjustment for the directional unit is made with the moving contact in the reset position, i.e., against the right side of the bridge. Advance the right hand stationary contact until the contacts make. Then advance the stationary contact an additional one-quarter turn. Now advance the left-hand stationary contact until it just touches the right-hand stationary contact. Then back off $3/4$ of a turn for approximately .025" gap.

The clamp holding the stationary contact housing need not be loosened for the adjustment since the clamp utilizes a spring-type action in holding the stationary contact in position.

The sensitivity adjustment is made by varying the tension of the spiral spring attached to the moving element assembly. The spring is adjusted by placing a screwdriver or similar tool into one of the notches located on the periphery of the spring adjuster and rotating it. The spring adjuster is located on the underside of the bridge and is held in place by a spring-type clamp that does not have to be loosened prior to making the necessary adjustments.

With rated voltage and .020 amperes applied at the maximum torque angle 30° current leading adjust the spring until the moving contact just makes with the left-hand stationary contact.

7.0 RENEWAL PARTS

Repair work can be done most satisfactorily at the factory. However, interchangeable parts can be furnished to the customers who are equipped for doing repair work. When ordering parts, always give the

complete nameplate data.

8.0 ENERGY REQUIREMENTS

Burden of the potential circuit at 120 volts, 60 cycles is 11.5 VA. The angle of the burden is 58° lagging. The burden of the current circuit at 5 amps is 13.85 VA. The angle of the burden is 25° lagging. The impedance of the burden is 0.55 ohms.

9.0 RATINGS

The continuous rating of the potential circuit is 132 volts.

The continuous rating of the current circuit is 5 amperes.

The one second rating of the current circuit is 140 amperes.

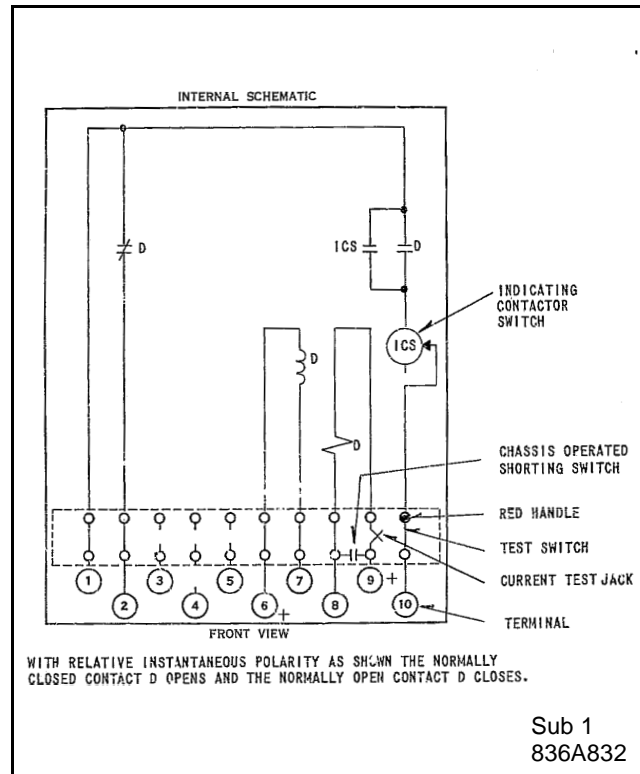

Figure 1: Internal Schematic (.2/2 Amp ICS)

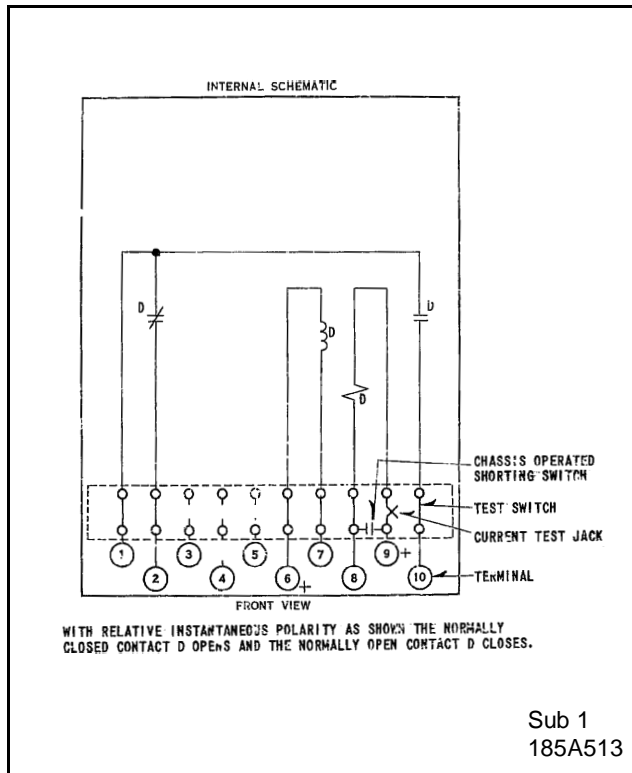

Figure 2: Internal Schematic

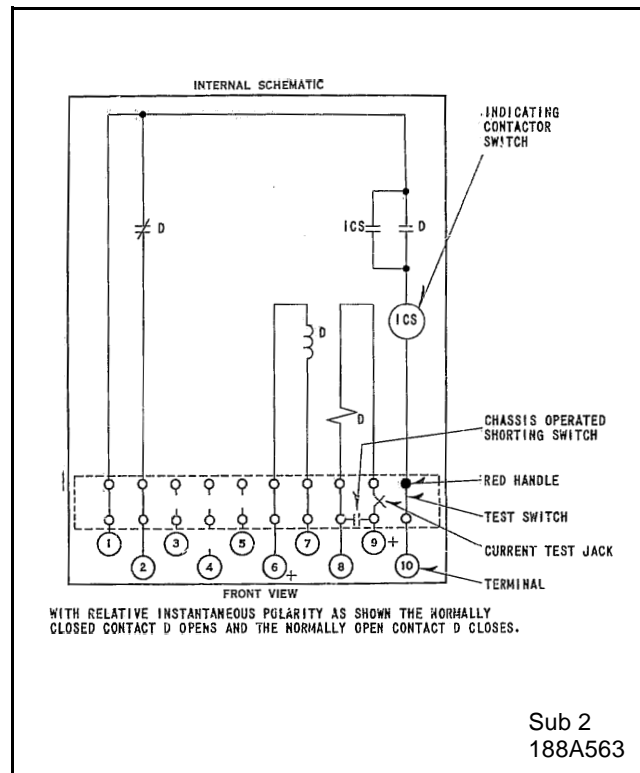

Figure 3: Internal Schematic (1Amp ICS)

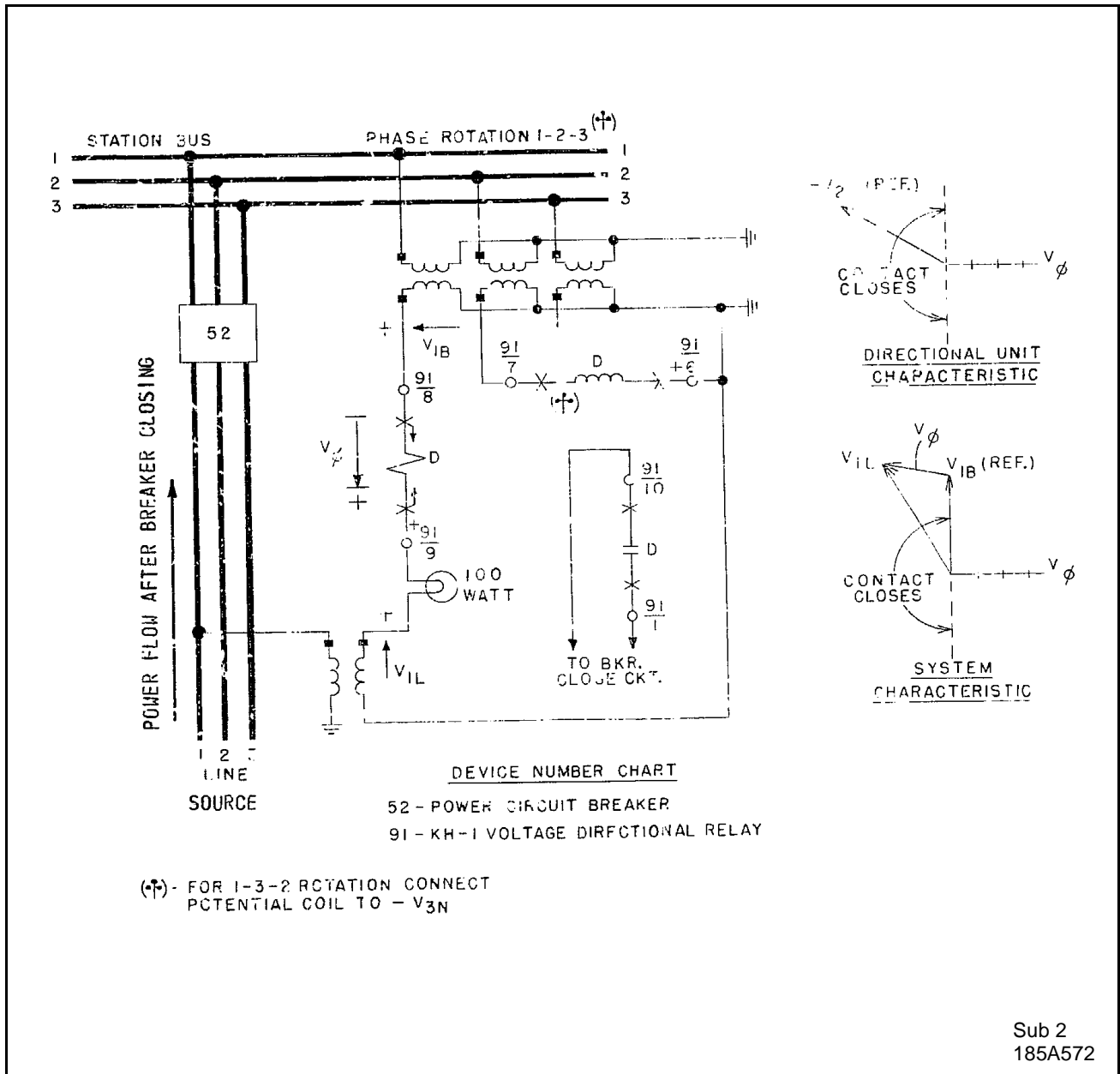

Figure 4: External Schematic of KH-1 Relay for Supervising Breaker Closing

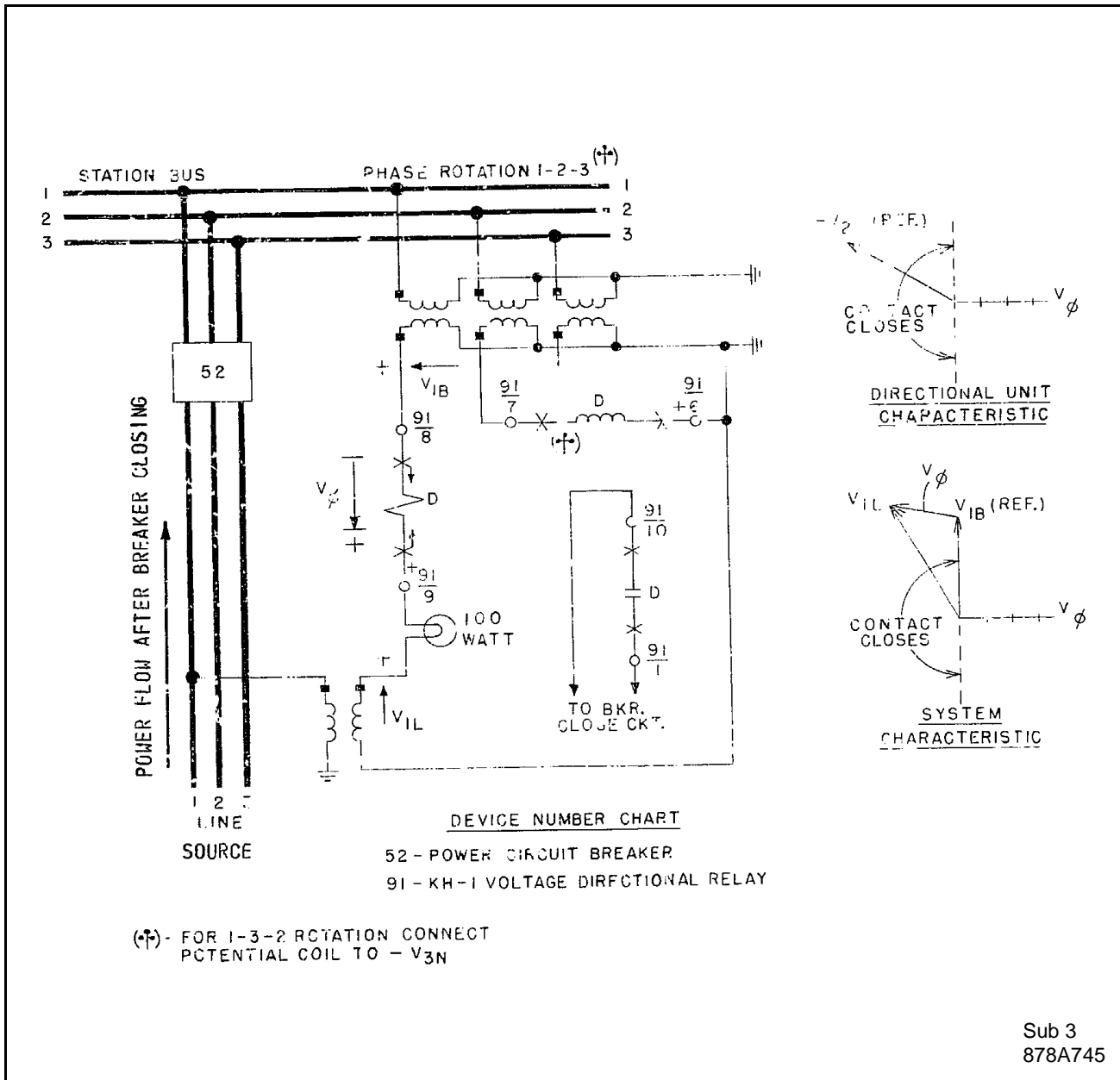

Figure 5: External Schematic for Over Power Protection

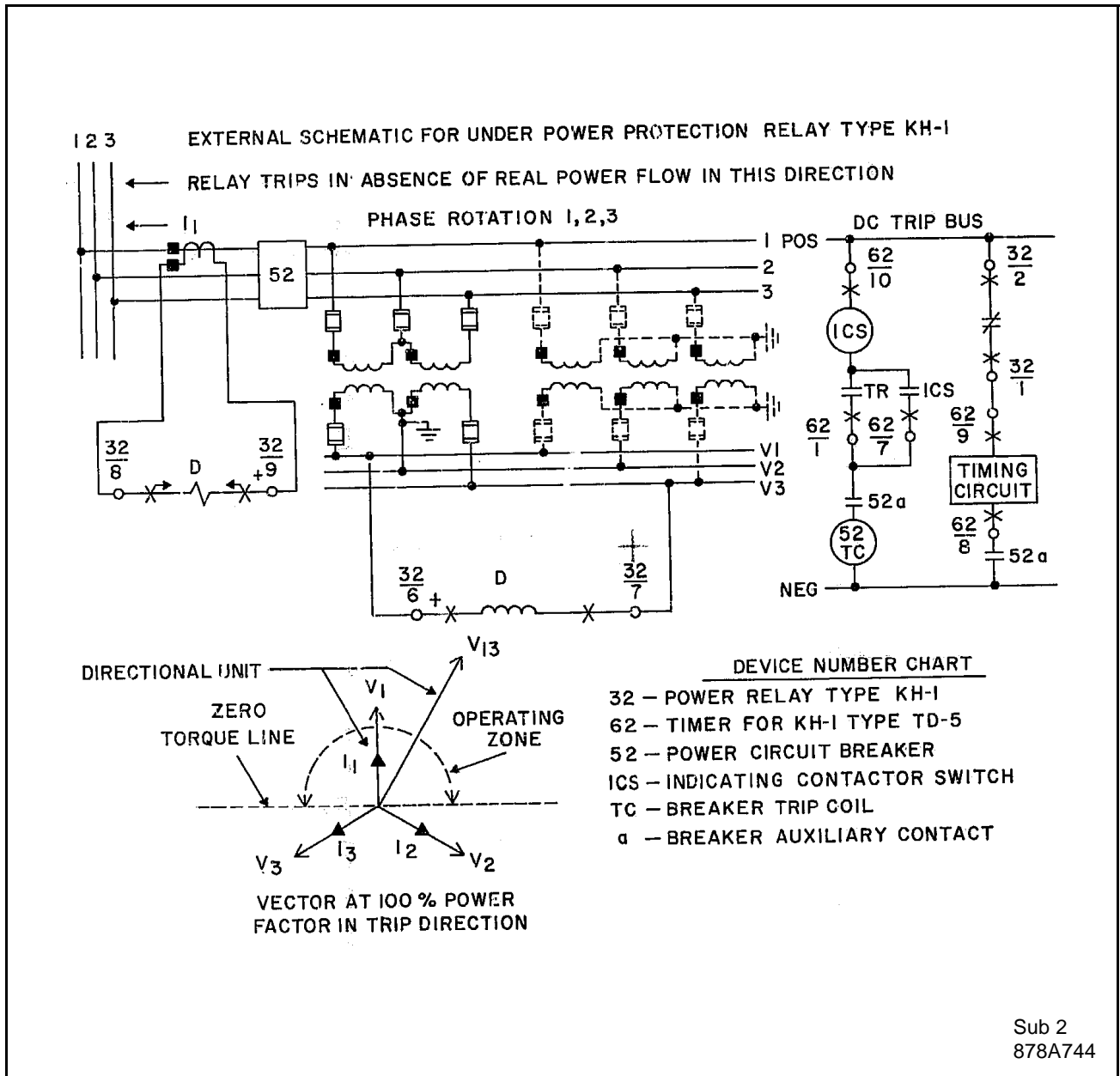

Figure 6: External Schematic for Under Power Protection

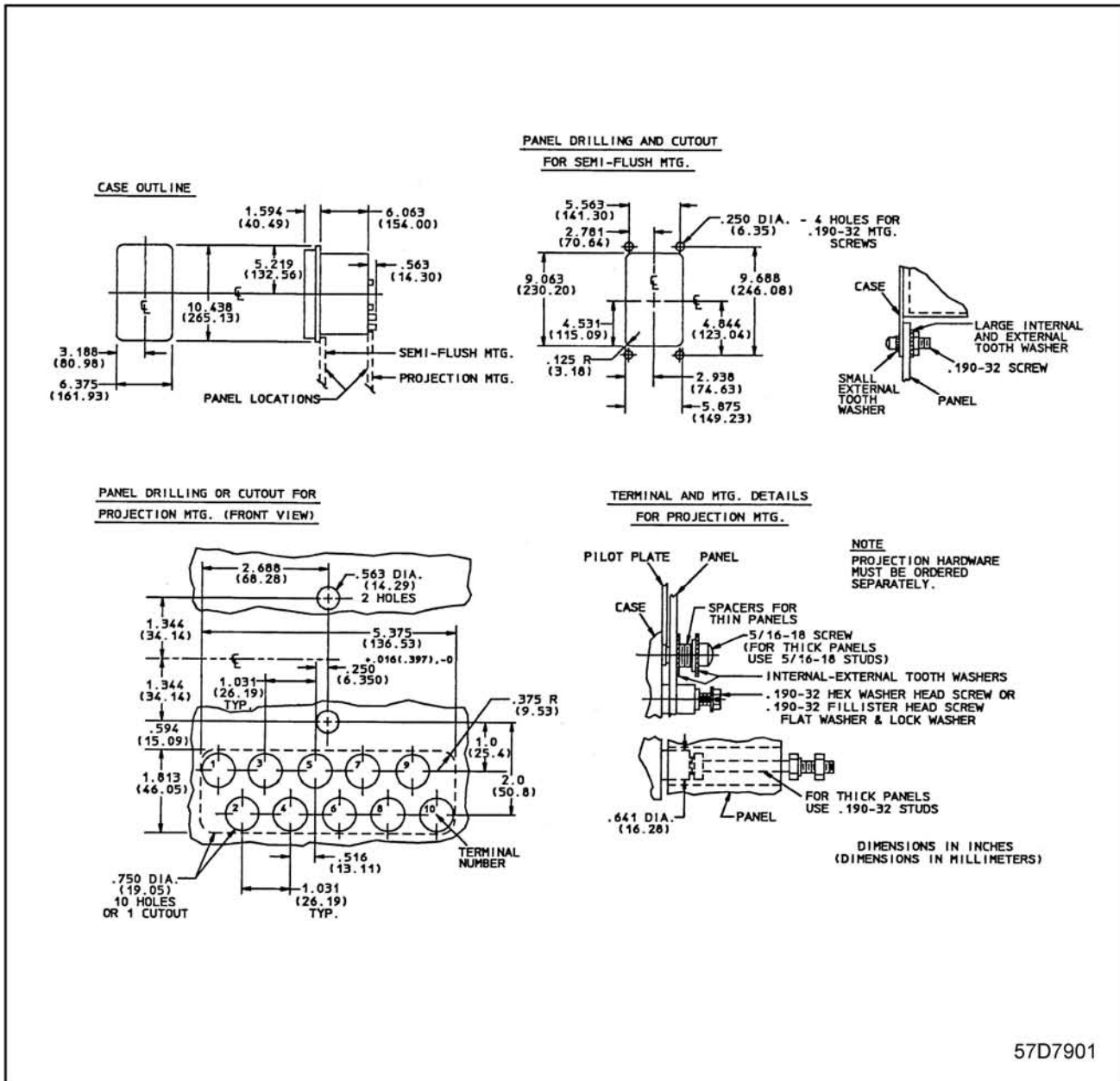

Figure 7: Outline and Drilling (Type FT-21 Case)



ABB Inc.
 4300 Coral Ridge Drive
 Coral Springs, Florida 33065
 Telephone: +1 954-752-6700
 Fax: +1 954-345-5329
 www.abb.com/substation automation