



Effective: August 1990
This Addendum Supersedes
All Previous Addenda

Type KC-4 Overcurrent Relay

A - Add New Information • C - Change Existing Information • D - Delete Information

C

Page 9 _____

SETTINGS, Phase and Ground Overcurrent Unit; change paragraphs 2 and 3 to read:

CAUTION

Since the tap block screw carries operating current, be sure that the screws are turned tight.

In order to avoid opening current transformer circuits when changing taps under load, the relay must be first removed from the case. Chassis operating shorting switches on the case will short the secondary of the current transformer. The taps should then be changed with the relay outside of the case and then reinserted into the case.

All possible contingencies which may arise during installation, operation or maintenance, and all details and variations of this equipment do not purport to be covered by these instructions. If further information is desired by purchaser regarding this particular installation, operation or maintenance of this equipment, the local ABB representative should be contacted.

THIS PAGE RESERVED FOR NOTES



Type KC-4 Overcurrent Relay

Effective: August 1985

Supersedes I.L. 41-776.1K, Dated September 1980

★ Denotes Change Since Previous Issue.

CAUTION: Before putting relays into service, remove all blocking which may have been inserted for the purpose of securing the parts during shipment, make sure that all moving parts operate freely, inspect the contacts to see that they are clean and close properly, and operate the relay to check the settings and electrical connections.

APPLICATION

The type KC-4 is a non-directional current or fault detector which operates for all phase and ground faults to supervise the tripping of other relays. It is particularly suited for breaker-failure relaying schemes, in which it indicates the presence or lack of current flow in the protected circuit breaker. The relay can be applied where the phase units are to be operated indefinitely in the picked up position, set well below full load. Alternatively, where the relay is to be used as a fault detector (pickup above full load) the 98% or better dropout ratio of the phase and ground units is advantageous.

Specific breaker failure schemes using the KC-4 relay, with detailed explanations, are given in the OPERATION section.

CONSTRUCTION

The type KC-4 relay consists of two phase instantaneous overcurrent units, (I_A and I_C), one ground instantaneous unit (I_0), and an indicating contactor switch (ICS). The principal component parts of the relay and their location are shown in Figure 1.

PHASE AND GROUND INSTANTANEOUS OVERCURRENT UNITS

(I_A , I_C , I_0)

Each instantaneous overcurrent unit consists of an induction cylinder unit, capacitor, varistor, and a transformer. The components are connected such that a contact closing torque is produced when the current exceeds a specified value.

INDUCTION CYLINDER UNIT

Mechanically, the cylinder unit is composed of four basic components: a diecast aluminum frame, an electromagnet, a moving element assembly, and a molded bridge.

The frame serves as the mounting structure for the magnetic core. The magnetic core which houses the lower pin bearing is secured to the frame by a locking nut. The bearing can be replaced, if necessary, without having to remove the magnetic core from the frame.

The electromagnet has two pairs of coils. The coils of each pair are mounted diametrically opposite one another, and a capacitor is connected in series with one pair of coils. In addition, there are two locating pins. The locating pins are used to accurately position the lower pin bearing, which is threaded into the bridge. The electromagnet is secured to the frame by four mounting screws.

The moving element assembly consists of a spiral spring, contact carrying member, and an aluminum cylinder assembled to a molded hub

All possible contingencies which may arise during installation, operation or maintenance, and all details and variations of this equipment do not purport to be covered by these instructions. If further information is desired by purchaser regarding this particular installation, operation or maintenance of this equipment, the local ABB representative should be contacted.

which holds the shaft. The shaft has removable top and bottom jewel bearings. The shaft rides between the bottom pin bearing and the upper pin bearing with the cylinder rotating in an air gap formed by the electromagnet and the magnetic core.

The bridge is secured to the electromagnet and frame by two mounting screws. In addition to

holding the upper pin bearings, the bridge is used for mounting the adjustable stationary contact housing. The stationary contact housing is held in position by a spring type clamp. The spring adjuster is located on the underside of the bridge and is attached to the moving contact arm by a spiral spring. The spring adjuster is also held in place by a spring type clamp.

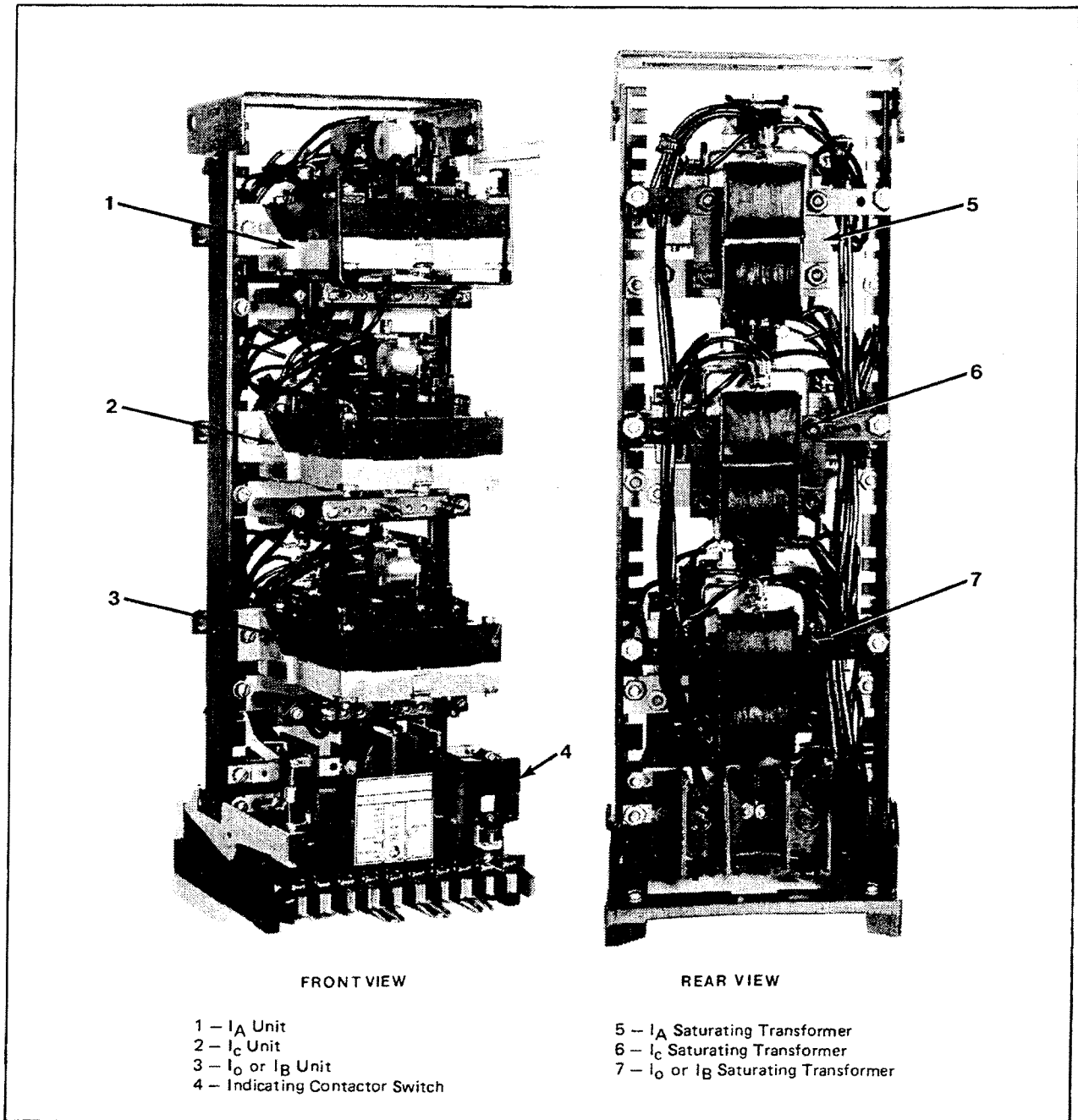

Fig. 1. Type KC-4 Relay Without Case.

With the contact closed, the electrical connection is made through the stationary contact housing clamp, to the moving contact, through the spiral spring out to the spring adjuster clamp.

TRANSFORMER

The transformer is a saturating type consisting of a tapped primary winding and a secondary winding. A varistor is connected across the secondary winding to reduce the voltage peaks applied to the induction cylinder unit and phase shifting capacitor.

INDICATING CONTACTOR SWITCH UNIT (ICS)

The indicating contactor switch is a small dc operated clapper type device. A magnetic armature, to which leaf-spring mounted contacts are attached, is attracted to the magnetic core upon energization of the switch. When the switch closes, the moving contacts bridge two stationary contacts, completing the trip circuit. Also during this operation two fingers on the armature deflect a spring located on the front of the switch, which allows the operation indicator target to drop. The target is reset from the outside of the case by a push rod located at the bottom of the cover.

The front spring, in addition to holding the target, provides restraint for the armature and thus controls the pickup value of the switch.

OPERATION

INSTANTANEOUS OVERCURRENT UNIT

Operation of the instantaneous overcurrent unit occurs when the primary current of the transformer exceeds a value as marked on the tap plate. Upon application of current to the transformer, a voltage is induced in the secondary winding. This voltage is impressed upon the parallel connected pairs of cylinder unit coils. The capacitor connected in series with one pair of coils shifts the current flowing in these coils in reference to the current flowing in the other pair of coils. As a result, the air gap fluxes of the cylinder unit are out of phase and a contact closing torque is produced.

The primary of the transformer is tapped and brought out to a tap connector block for ease in changing the pickup current of the relay. The use of a tapped transformer provides approximately the same energy level at a given multiple of pickup current for any tap setting, resulting in one time curve throughout the range of the relay.

BREAKER FAILURE SCHEMES USING THE KC-4 RELAY

The following explanations frequently refer to the type TD-5 timing relay, which is usually used in conjunction with the KC-4 relay for breaker failure protection. For detailed data on the TD-5, refer to instruction leaflet 41-579.1.

SINGLE BUS/SINGLE BREAKER ARRANGEMENT

In a properly functioning breaker, current flow should cease shortly after the trip circuit is energized. The time interval between trip-circuit energization and current flow cessation is the breaker-interrupting time. If interruption doesn't occur within the specified interrupting time, the breaker is assumed to have failed and the breaker-failure relaying should initiate tripping of adjacent and/or remote breakers to isolate the protected breaker. For the single bus-single breaker configuration, all the breakers on the bus must be tripped to isolate any one of them which fails. This is readily accomplished by having the breaker-failure protection circuits energize the bus-differential lockout auxiliary 86B.

Figure 2 shows the simplest breaker-failure scheme using the KC-4 relay. Primary and backup line relays connected to separate current transformers and separately-fused dc supplies so that a failure in either circuit will not disable all of the protection. When primary protection operates, it energizes auxiliary relay 62X and the breaker trip coil simultaneously. Similarly, backup relays energize both tripping auxiliary 94T and auxiliary 62Y simultaneously. 62X and 62Y are known as breaker-failure initiate (BFI) auxiliaries. The closure of contacts 62X and 62Y provide a signal in the breaker failure scheme that breaker tripping

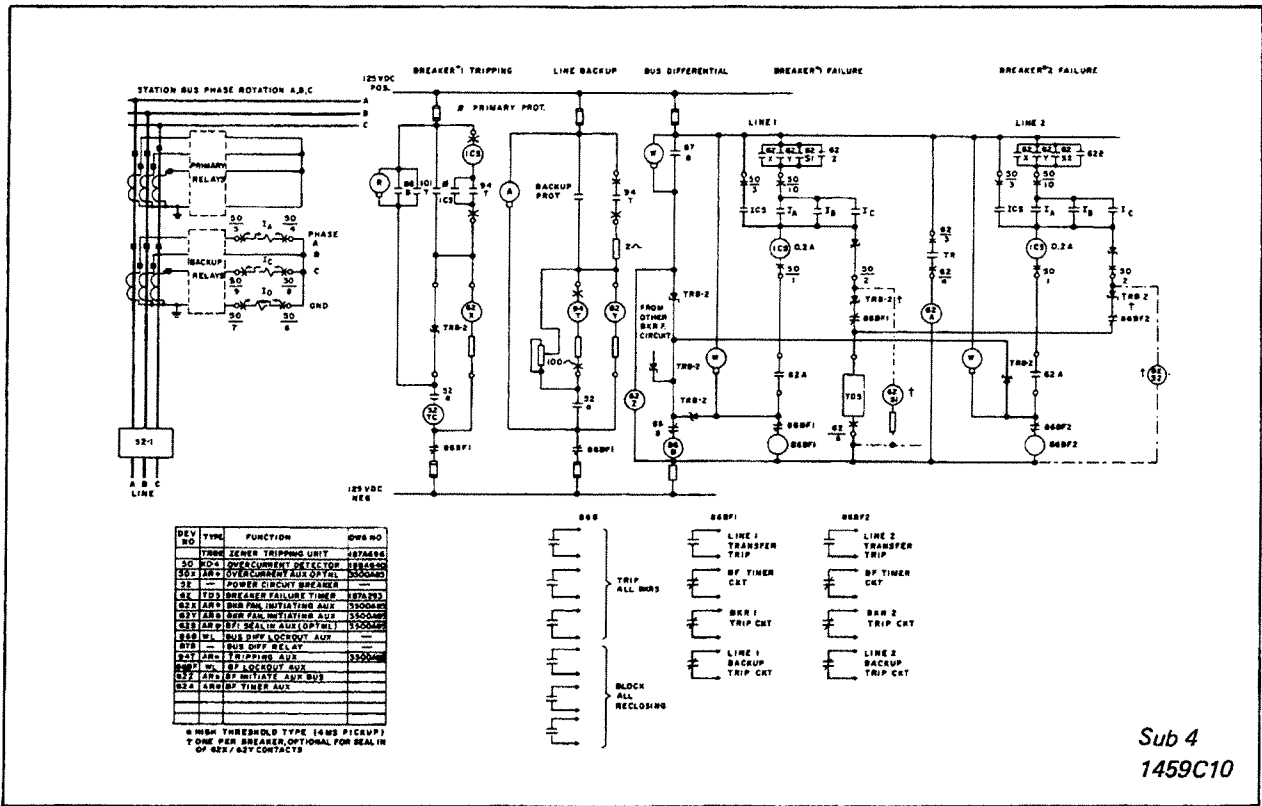

Fig. 2. External Connections for the KC-4 Relay – Breaker Failure Protection of a Single Bus/Single Breaker Arrangement – One Timer per Bus.

has been initiated. They energize the TD-5 breaker-failure timer (62) through the KC-4 (50) contacts, which have already closed in response to the same fault which operated the line relays. If the breaker interrupts fault current as expected, the KC-4 drops out and the TD-5 timer is de-energized before it times out; no further action is taken. But if current flow continues beyond the expected time limit, the TD-5 delay expires and the output (TR) contact of the TD-5 energizes the 62A auxiliary relay for contact multiplication. 62A contact energizes the 86B lockout auxiliary to strip the bus and block reclosing.

Note that, in figure 2, each breaker has its own line protection relays, BFI auxiliary and KC-4 current detector; but that all of these funnel into a single TD-5 timer. This is done for economy since the same tripping device, 86B, is energized regardless of which breaker fails. Targeting of the particular failed breaker is accomplished by the ICS in the associated KC-4 in conjunction with the 62X and 62Y BFI contacts for that line. The zener blocking diode inside each KC-4, connected to

terminal 50-2, isolates the multiple trip circuits of the KC-4's from one another so that only the target of the failed breaker will drop.

After the TD-5 has operated and picked up 62A, the 62A contact also energizes the 86BF auxiliary relay. Refer to the primary breaker tripping circuit. If a fault occurs and the breaker operating mechanism is stuck (the most frequent type of breaker failure), line relays energize the trip coil with no effect. The breaker failure scheme will operate the initiate backup tripping, eliminating threats to power system integrity. However, dc current will continue to flow in the primary relay ICS and in the breaker trip coil, uninterrupted by the stuck 52a contact. The trip coil, and other devices in the tripping path, are only intermittently rated and may disintegrate or ignite before operators or repair crews can intervene. For this reason, a normally-closed 86BF contact is shown in series with the trip circuit, to interrupt dc current flow.

After the TD-5 has operated, a sneak path may be created through the supervising lamp for the

Sub 4
1459C10

86BF coil, backwards through the closed 62A contact, through the KC-4 terminals 1 and 2, and finally into terminal 9 of the TD-5. This sneak current may prevent the TD-5 from dropping out, a normally-closed 86BF contact cuts off the TD-5.

In the primary breaker-tripping circuit, the TRB-2 blocking diode prevents red supervising-light current from flowing in the 62X coil.

In both the primary and the backup tripping circuits, the 62X and 62Y coils are connected to follow the protective relay contacts and should never be connected in series with 52a contacts. Otherwise, BFI is lost when the breaker functions mechanically, opening 52a, but fails to interrupt current flow. The resistor in parallel with the 94T auxiliary dissipates 625 Watts in a 125 Vdc control scheme. It draws sufficient current to hold an ICS in the line backup tripping circuits picked up, and may burn if the 52a contact doesn't open. A 86BF contact deenergizes the backup circuit to prevent this.

For a bus fault, the 87B relay contact energizes the 86B lockout auxiliary to strip the bus and block reclosing. The blocking valves TRB-2 prevent the 87B from energizing the 86BF auxiliaries. However, in case of breaker failure during a bus fault, the BFI auxiliary 62Z relay is picked up by 87B. The closure of contact 62Z provides a signal in the breaker failure scheme to energize the TD-5 timer, then picks up the corresponding 86BF auxiliary. 86BF contact initiates the transfer trip for isolating the faulted bus.

Figure 2 also shows how BFI seal-in can be provided when one timer is used per bus. The TD-5 relay containing the TX relay cannot be used here. A separate 62Z auxiliary relay is provided for each breaker, each with a TRB-2 blocking diode to isolate the circuits on multiple breakers from one another.

Figure 3 shows a breaker-failure scheme for the same bus arrangement. The key differences are that (a) now a separate TD-5 timer is dedicated to each breaker; and (b) in this scheme BFI seal-in is provided by the TX auxiliary in TD-5.

The telephone relay coil TX in parallel with the TD-5 timer 62 is optionally used to seal-in 62X and 62Y contacts. When the KC-4 contacts and 62X or Y contacts are both closed, both the timer circuit and TX are energized; TX seals around 62X and Y so that only the opening of the KC-4 contacts can stop the timer. This may be needed when 62X and Y are energized by potential-polarized distance relays. If a close-in fault occurs so that the polarizing potential collapses completely, the distance relay will reset after stored energy in the polarizing circuit damps out (usually 15 to 30 ms). This will cause dropout of 62X or Y, even if the breaker has failed and the fault remains. The TX contact will keep the timer energized for this critical situation, allowing the breaker failure scheme to function and strip the bus.

In figure 3, the ICS in the TD-5 now provides the seal-in and target functions, since a separate TD-5 is dedicated to each breaker.

With the KC-4 connected adjacent to the dc positive supply as shown in figure 3, a 50X auxiliary relay can be connected between terminal 2 of the KC-4 and dc negative. 50X then follows the KC-4 and provides contact multiplication. This allows the KC-4 to perform other non-breaker-failure functions. For example, a 50X contact can be used to supervise a distance relay trip circuit to prevent false-tripping on loss of ac potential supply.

Although using a separate timer for each breaker is more costly than the scheme of figure 2, there are several performance advantages:

- (1) For a fault which begins on one line and subsequently spreads to another (such as can occur on a double-circuit tower), the common timer in figure 2 will be energized by the initial fault. However, even if the breaker clears the first line affected, the 62X and Y contacts and KC-4 relay of the second faulted line will keep the timer energized. The time delay may expire and the bus may be stripped before the second breaker clears the fault, even though no breaker failed.

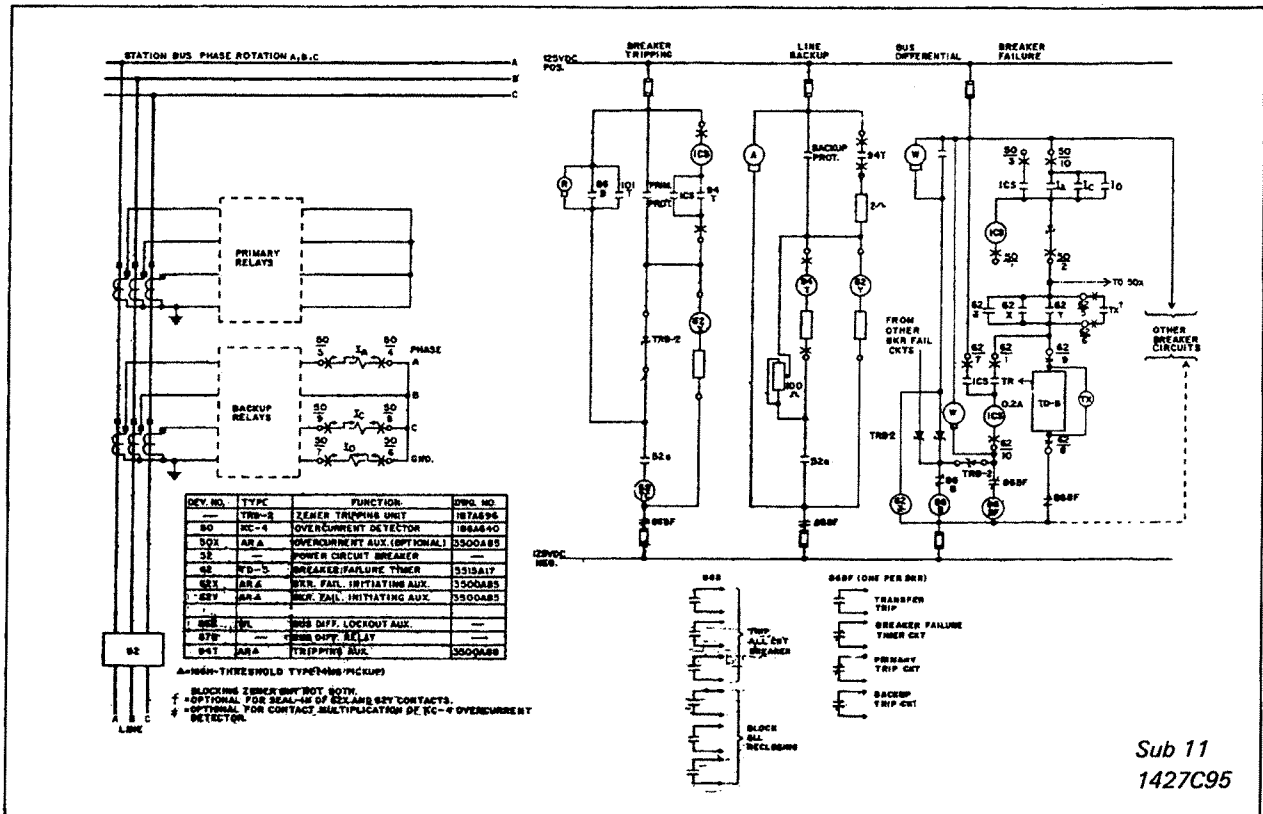

Fig. 3. External Connections for the KC-4 Relay – Breaker Failure Protection of a Single Bus/Single Breaker Arrangement with One Timer per Breaker.

- (2) If the breakers on the bus have different interrupting times, a common timer must be set to accommodate the slowest breaker. Separate timers provide faster backup clearing for fast breakers.
- (3) With separate timers, the bus can be reconfigured without rewiring the breaker failure circuits.
- (4) If BFI seal-in is needed it is easy to obtain with separate timers. With a single timer, auxiliary relays and blocking diodes must be added whose cost mitigates the timer savings.

BREAKER-AND-A-HALF ARRANGEMENT

Figure 4 show breaker-failure protection circuits for a breaker-and-a-half bus arrangement, with one timer for each breaker.

The basic functioning of the scheme of figure 4 is the same as for the single bus-single breaker case.

First, consider the breaker 1 failure detection circuit as an example for a breaker adjacent to a bus. Breaker-failure timing is initiated not only for faults on line A, but on bus L as well. Auxiliary relay 62Z-L in the Bus-L clearing circuit provides BFI to breaker-failure schemes for breakers 1, 4, and others on bus L whenever a bus fault occurs and bus differential relay 87B-L operates.

For a bus fault on L and a failure of breaker 1, the timer 62 will energize lockout switch 86BF directly which will in turn cause tripping and re-close blocking of breaker 2 and transfer tripping of breakers at the remote end of line A. The timer 62 also energizes lockout switch 86B-L through a TRB-2 blocking diode; this is not detrimental but is redundant since 86B-L was already tripped by the bus relay 87B-L.

Now consider a fault on line A and a failure of breaker 1. BFI is provided by 62X and Y. The timer 62 will energize 86Z and 86B-L through TRB-2 as just described. In this case, breaker 2 and remote-breaker tripping were already accom-

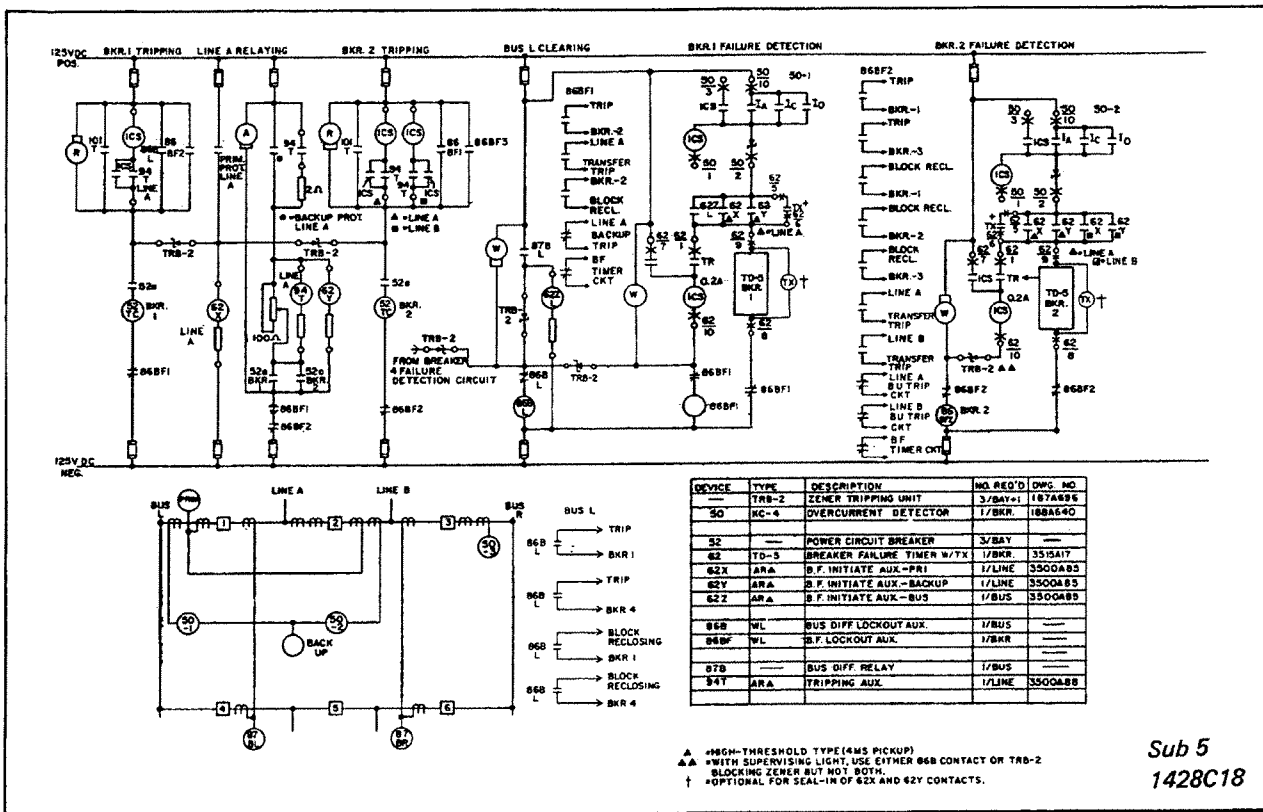

Sub 5
1428C18

Fig. 4. External Connections for the KC-4 Relay – Breaker Failure Protection of a Breaker-and-a-Half Bus Arrangement – One Timer per Breaker.

plished by line relays, so these actions are redundant. However, the blocking of reclosing for breaker 2, and reclose blocking at the remote terminal via the transfer-trip signal, are now provided. Also, 86B-L now strips bus L to isolate the failed breaker 1.

Now, refer to the breaker 2 failure detection circuit. BFI is provided by 62X and Y contacts for lines A and B, since a fault on either initiates tripping of breaker 2. If breaker 2 fails and the timer 62 delay expires, lockout switch 86BF is energized. Contacts of 86BF trip breakers 1 and 3, block reclosing on all 3 breakers, and transfer-trip lines A and B. Some of these actions are redundant—for example, a line A fault does not require re-tripping of breaker 1. But none of these redundant actions are detrimental. Remember that transfer-tripping of the remote end of the faulted line isn't really redundant since it performs the important additional function of blocking reclosing at the remote terminal.

The TX relay is shown providing optional seal-in of BFI contacts as described for the single-bus single-breaker case above.

As mentioned before, on breaker failure protection, a separate timer for each breaker has an advantage over a common timer per bus, and also most of the breaker-and-a-half bus arrangements are applied to the rather high voltage system. Therefore, it is recommended that a separate timer be applied for each breaker for the breaker-and-a-half bus arrangement.

RING BUS ARRANGEMENT

Figure 5 shows the line and breaker-failure protection circuits for a ring bus. The symmetry of the bus permits a simple circuit for the latter function. Using breaker 2 as an example, BFI is provided by 62X and 62Y contacts from lines A and B, since a fault on either line initiates breaker 2 tripping. If the time delay expires, the lockout switch 86BF trips adjacent breakers 1 and 3;

blocks reclosing of breakers 1, 2, and 3; and transfer-trips both line A and line B. As in the breaker-and-a-half scheme, redundant actions are allowed since they cause no difficulties and result in the simplest scheme. Recall that the transfer-tripping of the faulted line isn't really redundant since it provides the critical reclose-blocking function at the far terminal, as in the previous cases.

SETTING THE KC-4 FOR BREAKER FAILURE PROTECTION

In all of these schemes, the KC-4 phase-unit pickup should be set above maximum load but below minimum fault current levels. The residual current unit should be set below the minimum ground fault current. If the largest load exceeds the minimum fault current, the KC-4 must be set below the minimum fault, and the user must accept a slight reduction in security. At times of heavy load, the KC-4 contacts are closed even though no fault is present.

In the past, 52a contacts have occasionally been connected in parallel with the KC-4 to allow timer starting for light faults below the KC-4 setting. This practice is *not* recommended, since the 52a is closed whenever the line is in service and the security benefits of KC-4 supervision are completely lost. Also, breaker-failure protection is incomplete since opening of the 52a contact after relay operation doesn't show that fault current was actually interrupted—it only shows that the trip mechanism cycled. A lower KC-4 setting is a better alternative.

Sometimes, a transformer connected to one side of the protected breaker can present a particular setting problem. Light-current faults may occur inside the transformer for which the KC-4 relay won't pick up. Thus, no breaker-failure protection is provided when differential or sudden-pressure relays initiate tripping. To remedy this, connect a 52a contact in series with an 86T contact from the breaker-failure dc positive supply to terminal 9 of the TD-5 timer 62 (86T is a contact of the lockout switch associated with the transformer differential relay). Repeat this connection for each breaker which is adjacent to the transformer.

The 86T contact supervision insures that security is not reduced by the added connection. If a transformer fault results in 86T tripping, the timer is energized and is stopped only when 52a opens. This won't happen if the breaker is stuck, and backup tripping is initiated. The only combination of circumstances for which this connection doesn't help is a light transformer fault, and a breaker which opens but doesn't interrupt. Many utilities consider this unlikely and provide no further protection against it. The only alternative is to replace 52a with a separate low-set current detector, which can energize the timer only when 86T closes.

CHARACTERISTICS

Phase & Ground Overcurrent Units are available in the following current ranges:

Range	Taps					
	0.5	0.75	1.0	1.25	1.5	2
0.5-2 Amps	0.5	0.75	1.0	1.25	1.5	2
1-4	1.0	1.5	2.0	2.5	3.0	4.0
2-8	2	3	4	5	6	8
4-16	4	6	8	9	12	16
10-40	10	15	20	24	30	40
20-80	20	30	40	48	60	80

The tap value is the minimum current required to just close the overcurrent relay contacts. For pickup settings in between taps refer to the section under adjustments. The pickup and dropout time curves for the overcurrent units shown in Fig. 6.

TRIP CIRCUIT

The main contacts will safely close 30 amperes at 250 volts dc and the seal-in contacts of the indicating contactor switch will safely carry this current long enough to trip a circuit breaker.

The indicating contactor switch has two taps that provide a pickup setting of 0.2 or 2 amperes. To change taps requires connecting of lead located in front of the tap block to the desired setting by means of a screw connection.

TRIP CIRCUIT CONSTANTS

Indicating Contactor Switch —

- 0.2 amp. tap 6.5 ohms d-c resistance
- 2.0 amp. tap 0.15 ohms dc resistance
- 1.0 amp. tap (when supplied) 0.1 ohm dc

SETTINGS

PHASE & GROUND OVERCURRENT UNIT

The pickup current setting is made by means the connector screw located on the tap plate. By placing the connector screw in the desired tap, the relay will just close its contacts at the tap value current.

CAUTION: *Since the tap block connector screw carries operating current, be sure that the screw is turned tight.*

In order to avoid opening the current transformer circuits when changing taps under load, connect the spare tap screw in the desired tap position before removing the other tap screw from the original tap position.

INDICATING CONTACTOR SWITCH (ICS)

Connect the lead located in front of the tap block to the desired setting by means of the connecting screw. When the relay energizes a 125- or 250-volt dc type WL relay switch or equivalent, use the 0.2 ampere tap; for 48-volt dc applications set in 2 tap and use WL coil S#304C209G01.

INSTALLATION

The relays should be mounted on switchboard panels or their equivalent in a location free from dirt, moisture, excessive vibration and heat. Mount the relay vertically by means of the rear mounting stud or studs for the type FT projection case or by means of the four mounting holes on the flange for the semi-flush type Ft case. Either the stud or the mounting screws may be utilized for grounding the relay. External toothed washers are provided for use in the locations shown on the outline and drilling plan to facilitate making a good electrical connection between the relay case, its mounting screws or studs, and the relay panel. Ground wires and affixed to the mounting screws or studs as required for poorly grounded or insulating panels. Other electrical connections may be made directly to the terminals by means of screws for steel panel mounting or to the terminal stud furnished with the relay for thick panel mounting. The terminal stud may be easily removed or inserted by locking

two nuts on the stud and then turning the proper nut with a wrench.

For detail information on the FT case refer to I.L. 41-076.

ADJUSTMENTS AND MAINTENANCE

The proper adjustments to insure correct operation of this relay have been made at the factory. Upon receipt of the relay, no customer adjustments, other than those covered under "SETTINGS," should be required.

ACCEPTANCE CHECK

The following check is recommended to insure that the relay is in proper working order:

Phase & Ground Overcurrent Unit

1. Contact Gap — The gap between the stationary and moving contacts with the relay in the deenergized position should be approximately .020."

2. Minimum Trip Current — The pick-up of the overcurrent unit can be checked by inserting the tap screw in the desired tap hole and applying rated tap value current. The contact should close within $\pm 5\%$ of tap value current.

Indicating Contactor Switch (ICS)

Close the phase or ground relay contacts and pass sufficient d-c current through the trip circuit to close the contacts of the ICS. This value of current should not be greater than the particular ICS tap setting being used. The indicator target should drop freely.

The contact gap should be approximately .047" between the bridging moving contact and the adjustable stationary contacts. The bridging moving contact should touch both stationary contacts simultaneously.

ROUTINE MAINTENANCE

All relays should be inspected periodically and the operation should be checked at least once every year or at such other time intervals as may be dictated by experience to be suitable to the particular application.

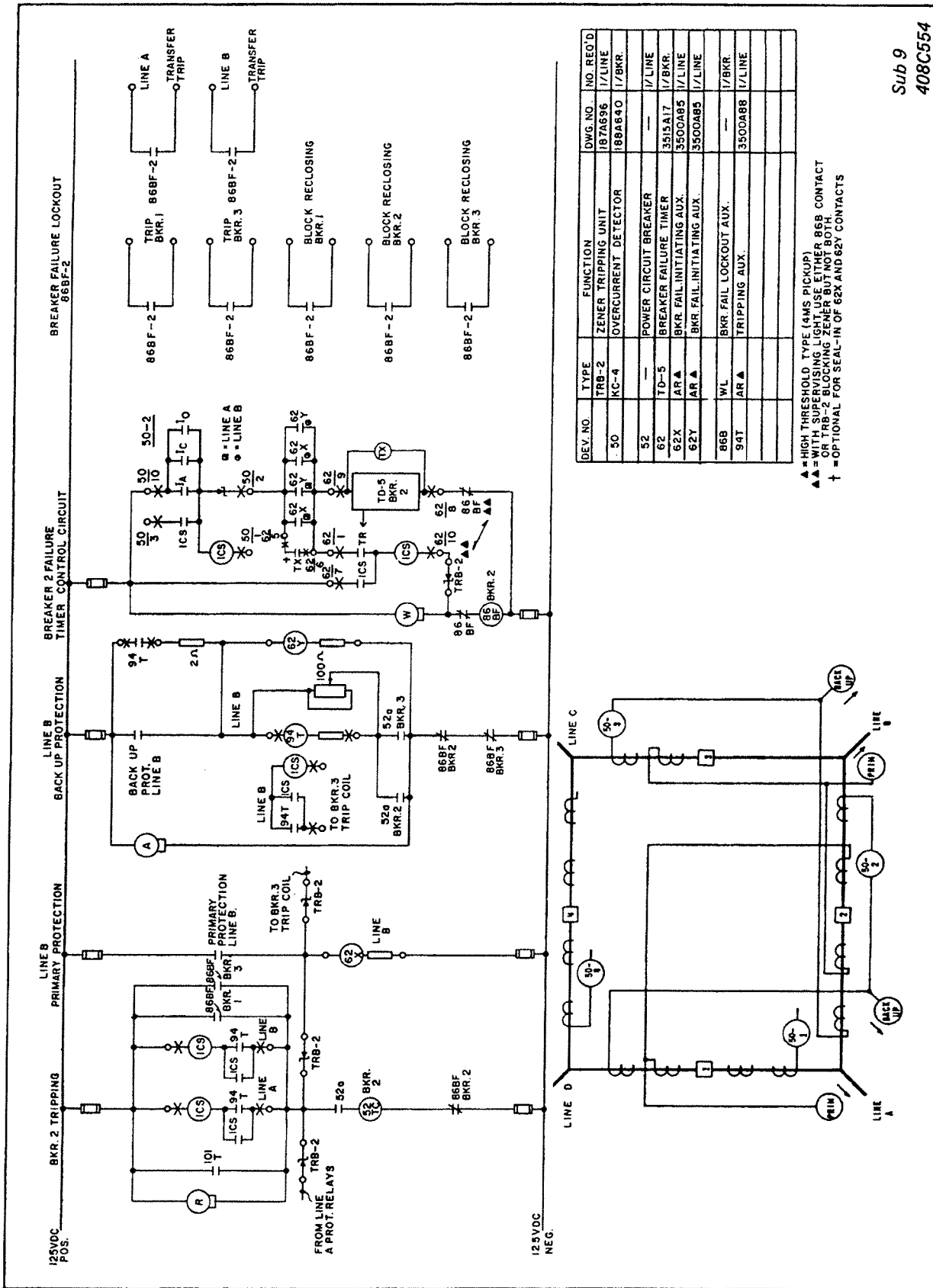

Sub 9
408C554

Fig. 5. External Connections for the KC-4 Relay - Breaker Failure Protection of a Ring Bus.

ENERGY REQUIREMENTS - 60 Hz

PHASE & GROUND OVERCURRENT UNIT - 60 Hz					
AMPERE RANGE	TAP	†† VA AT TAP VALUE	∅ P.F. ANGLE	†† VA AT 5 AMPS.	∅ P.F. ANGLE
.5-2	.5	.37	39	24	46
	.75	.38	36	13	37
	1	.39	35	8.5	34
	1.25	.41	34	6.0	32
	1.5	.43	32	4.6	31
	2	.45	30	2.9	28
1-4	1	.41	36	9.0	36
	1.5	.44	32	5.0	32
	2	.47	30	3.0	29
	2.5	.50	28	2.1	27
	3	.53	26	1.5	26
	4	.59	24	0.93	24
2-8	2	1.1	49	6.5	48
	3	1.2	43	3.3	42
	4	1.3	38	2.1	37
	5	1.4	35	1.4	35
	6	1.5	33	1.1	33
	8	1.8	29	0.7	29
4-16	4	1.5	51	2.4	51
	6	1.7	45	1.2	45
	8	1.8	40	0.7	40
	9	1.9	38	0.6	38
	12	2.2	34	0.37	34
	16	2.5	30	0.24	31
10-40	10	1.7	28	0.43	28
	15	2.4	21	0.27	21
	20	3.1	16	0.20	17
	24	3.6	1.5	0.15	15
	30	4.2	12	0.11	13
	40	4.9	11	0.08	12
20-80	20	6.6	31	0.40	31
	30	9.3	24	0.25	24
	40	12	20	0.18	20
	48	13.5	18	0.14	18
	60	15.9	16	0.10	16
	80	19.2	15	0.07	15

†† Voltages taken with Rectox type voltmeter.

∅ Degrees current lags voltage.

KC-4 50Hz BURDEN DATA					
AMPERE RANGE	TAP	†† VA AT TAP VALUE	θ P.F. ANGLE	†† VA AT 5 AMPS.	θ P.F. ANGLE
.5-2	.5	.35	36	24	34
	.75	.36	33	13	32
	1	.37	32	8.0	31
	1.25	.39	31	5.5	30
	1.5	.41	29	4.5	28
	2	.43	27	2.8	26
1-4	1	.35	35	8.8	36
	1.5	.38	31	4.8	30
	2	.41	29	2.8	28
	2.5	.44	27	2.0	27
	3	.47	25	1.4	25
2-8	4	.53	23	.92	23
	2	1.04	45	6.2	45
	3	1.1	41	3.2	41
	4	1.2	36	2.0	36
	5	1.3	33	1.2	33
	6	1.4	31	1.0	31
4-16	8	1.7	27	0.6	27
	4	1.26	43	2.1	42
	6	1.5	40	0.9	40
	8	1.6	37	.5	37
	9	1.7	34	.4	34
	12	2.0	31	.35	31
10-40	16	2.2	28	.20	28
	10	1.9	39	.45	39
	15	3.6	36	.40	36
	20	5.8	34	.35	34
	24	7.8	31	.30	31
	30	10.5	29	.27	29
40	17.5	27	.25	27	

†† Voltages taken with Rectox type voltmeter.

θ Degrees current lags voltage.

CURRENT RATINGS (50 & 60 Hz)

RATING OF THE OVERCURRENT UNITS (PHASE & GROUND)		
Range	Continuous Rating (Amperes)	One Second Rating (Amperes) †
0.5-2	5	100
1-4	8	140
2-8	8	140
4-16	10	200
10-40	10	200
20-80	10	200

† Thermal capacities for short times other than one second may be calculated on the basis of time being inversely proportional to the square of the current.

All contacts should be periodically cleaned. A contact burnisher S#182A836H01 is recommended for this purpose. The use of abrasive material for cleaning contacts is not recommended, because of the danger of embedding small particles in the face of the soft silver and thus impairing the contact.

CALIBRATION

Use the following procedure for calibrating the relay if the relay has been taken apart for repairs or the adjustments have been disturbed. This procedure should not be used unless it is apparent that the relay is not in proper working order. (See "Acceptance Check").

Phase and Ground Overcurrent Unit

The moving contact assembly has been factory adjusted for low contact bounce performance and should not be changed.

The set screw in the stationary contact has been shop adjusted for optimum follow and this adjustment should not be disturbed.

1. The upper pin bearing should be screwed down until there is approximately 1/64" clearance between it and the top of shaft bearing. The upper pin bearing should then be securely locked in position with the lock nut. The lower bearing position is fixed and cannot be adjusted.

2. The contact gap adjustment for the overcurrent unit is made with the moving contact in the reset position, (against the right side of the bridge.) Advance the stationary contact until the contacts just close. Then back off the stationary contact 2/3 of one turn for a gap of approximately .020". The clamp holding the stationary contact housing need not be loosened for the adjustment since the clamp utilizes a spring-type action in holding the stationary contact in position.

3. The sensitivity adjustment is made by varying the tension of the spiral spring attached to the

moving element assembly. The spring is adjusted by placing a screwdriver of similar tool into one of the notches located on the periphery of the spring adjuster and rotating it. The spring adjuster is located on the underside of the bridge and is held in place by a spring type clamp that does not have to be loosened prior to making the necessary adjustments.

Insert the tap screw in the minimum value tap setting and adjust the spring such that the contacts will close when energized with the required current. The pick up of the overcurrent unit with the tap screw in any other tap should be within $\pm 5\%$ of tap value.

If adjustment of pick-up current in between tap settings is desired, insert the tap screw in the next lowest tap setting and adjust the spring as described. It should be noted that this adjustment results in a slightly different time characteristic curve and burden.

Indicating Contactor Switch (ICS)

Close the main relay contacts and pass sufficient dc current through the trip circuit to close the contacts of the ICS. This value of current should be not greater than the particular ICS tap setting being used. The operation indicator target should drop freely.

The contact gap should be approximately .047" between the bridging moving contact and the adjustable stationary contacts. The bridging moving contact should touch both stationary contacts simultaneously.

RENEWAL PARTS

Repair work can be done most satisfactorily at the factory. However, interchangeable parts can be furnished to the customers who are equipped for doing repair work. When ordering parts, always give the complete nameplate data.

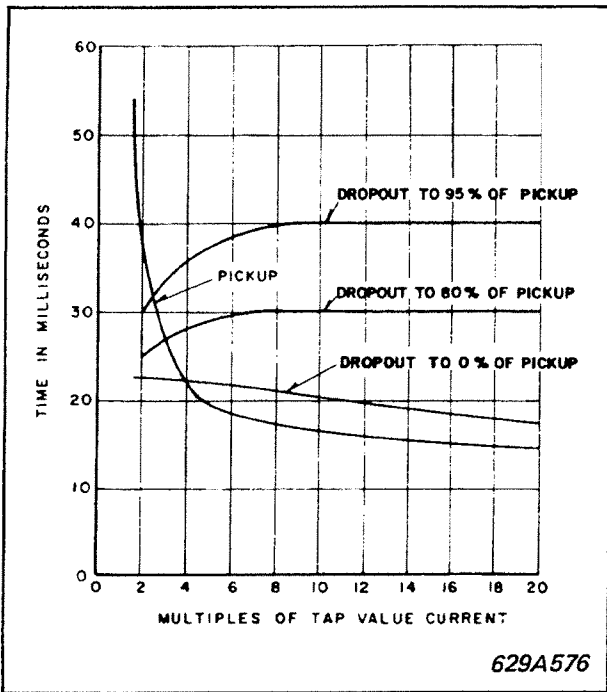

Fig. 6. Maximum Pick-Up and Drop-Out Time Curves for the Phase and Ground Overcurrent Units

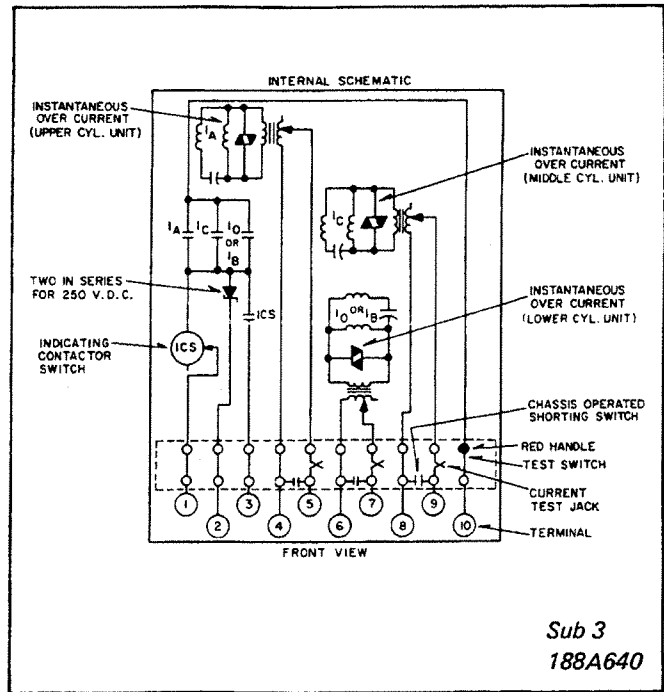

Fig. 7. Internal Schematic of the KC-4 Relay in the FT-41 Case.

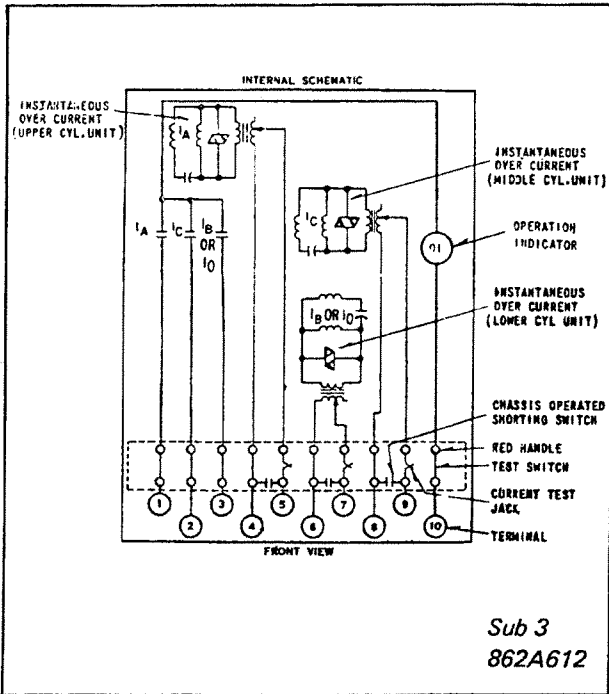

Fig. 8. Internal Schematic of the KC-4 Relay with Operation Indicator and Contacts to separate terminals in FT-41 case.

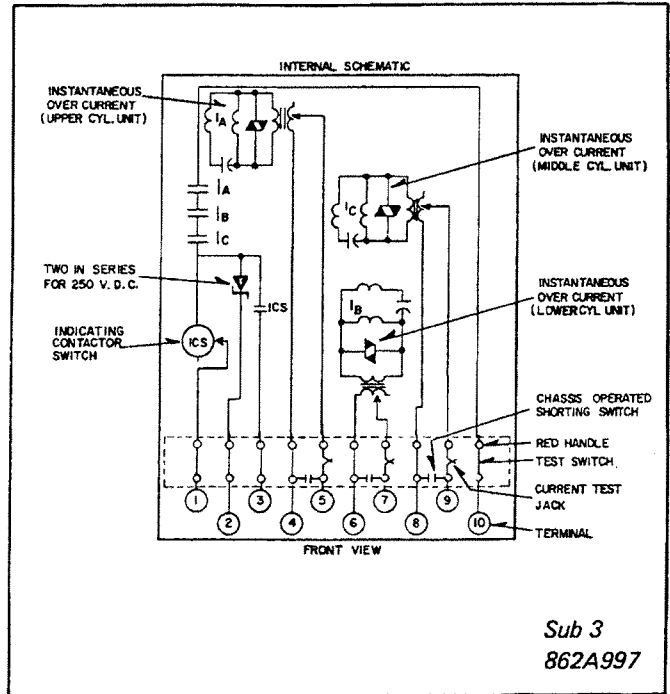
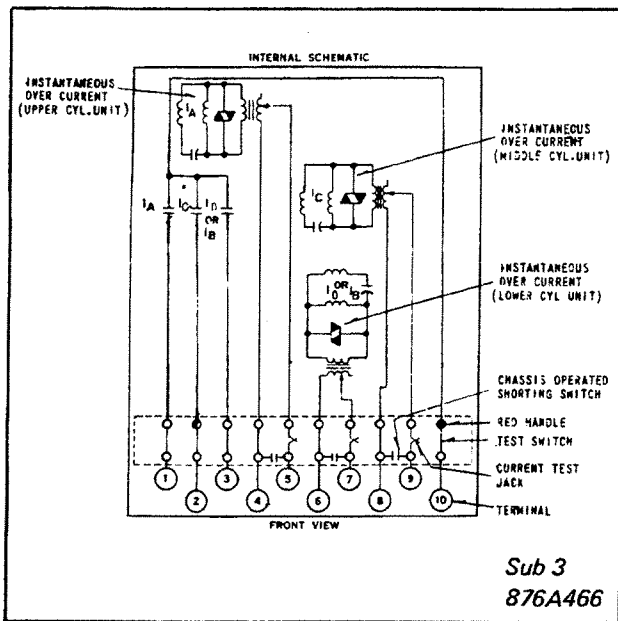
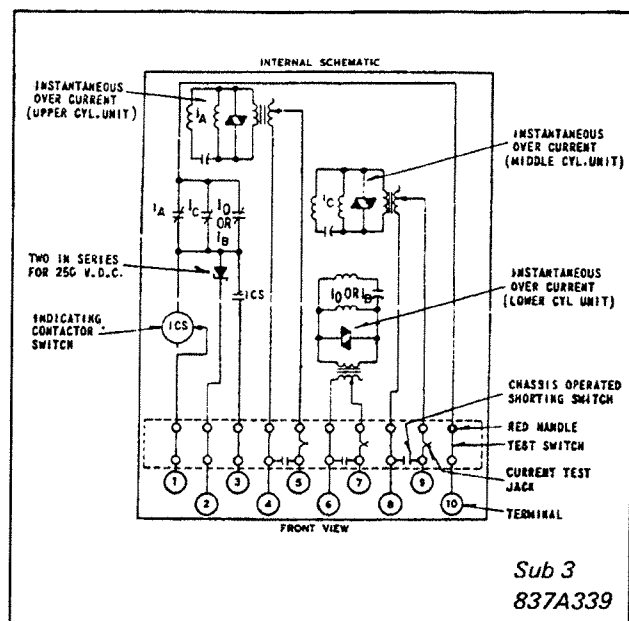

Fig. 9. Internal Schematic of the KC-4 Relay with Series Make Contacts in FT-41 Case.



★ Fig. 10. Internal Schematic of the KC-4 Relay with one side of Contacts to Separate Terminals in FT-41 Case.



★ Fig. 11. Internal Schematic of the KC-4 Relay with Normally Closed Contacts in FT-41 Case.

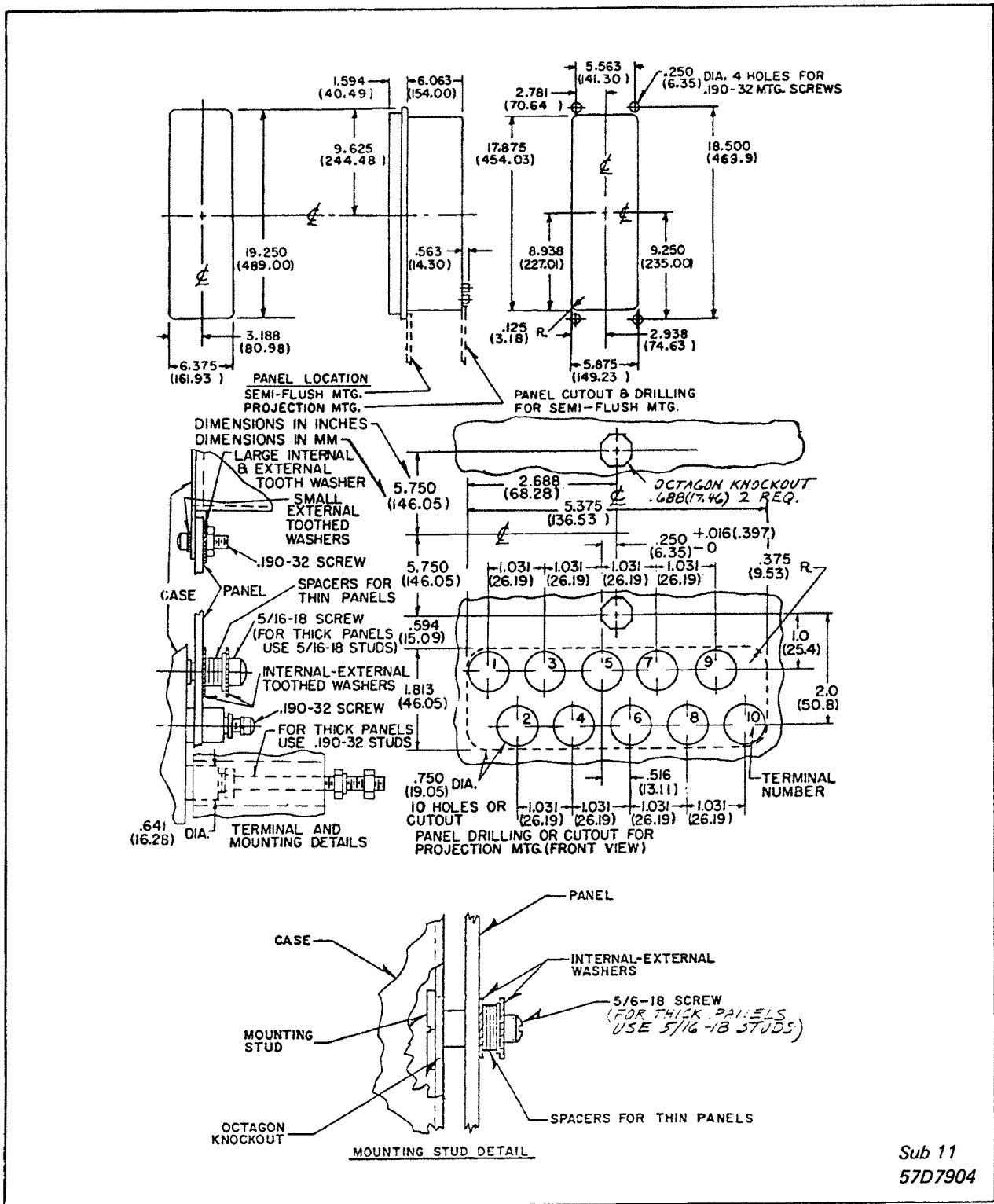

Sub 11
57D7904

• Fig. 12. Outline and Drilling Plan for the KC-4 Relay in FT-41 Case.

NOTES



ABB Inc.

4300 Coral Ridge Drive
Coral Springs, Florida 33065

Telephone: +1 954-752-6700

Fax: +1 954-345-5329

www.abb.com/substation_automation

IL 41-776.1 - Revision L