

DRAF09...16-.. , FR16AF-12(U)

1SBC101048M6801 - 05/15

Dol starter DRAF09...16, enclosure FR16AF-12(U)
 Motorstarter DRAF09...16, Gehäuse FR16AF-12(U)
 Démarreur direct DRAF09...16, coffret FR16AF-12(U)
 Motorskydsbrytare DRAF09...16, kapsling FR16AF-12(U)
 Telesalvamotori DRAF09...16, cassette FR16AF-12(U)
 Arrancadores DRAF09...16, caja FR16AF-12(U)
 马达起动机 DRAF09...16, 空壳体 FR16AF-12(U)
 ПУСКАТЕЛЬ ПРЯМОГО ПУСКА DRAF09...16, БОКС FR16AF-12(U)

Operating instructions
 Betriebsanleitung
 Notice d'instruction
 Instruktion
 Istruzioni tecniche
 Instrucciones de empleo
 操作说明
 Инструкция по эксплуатации

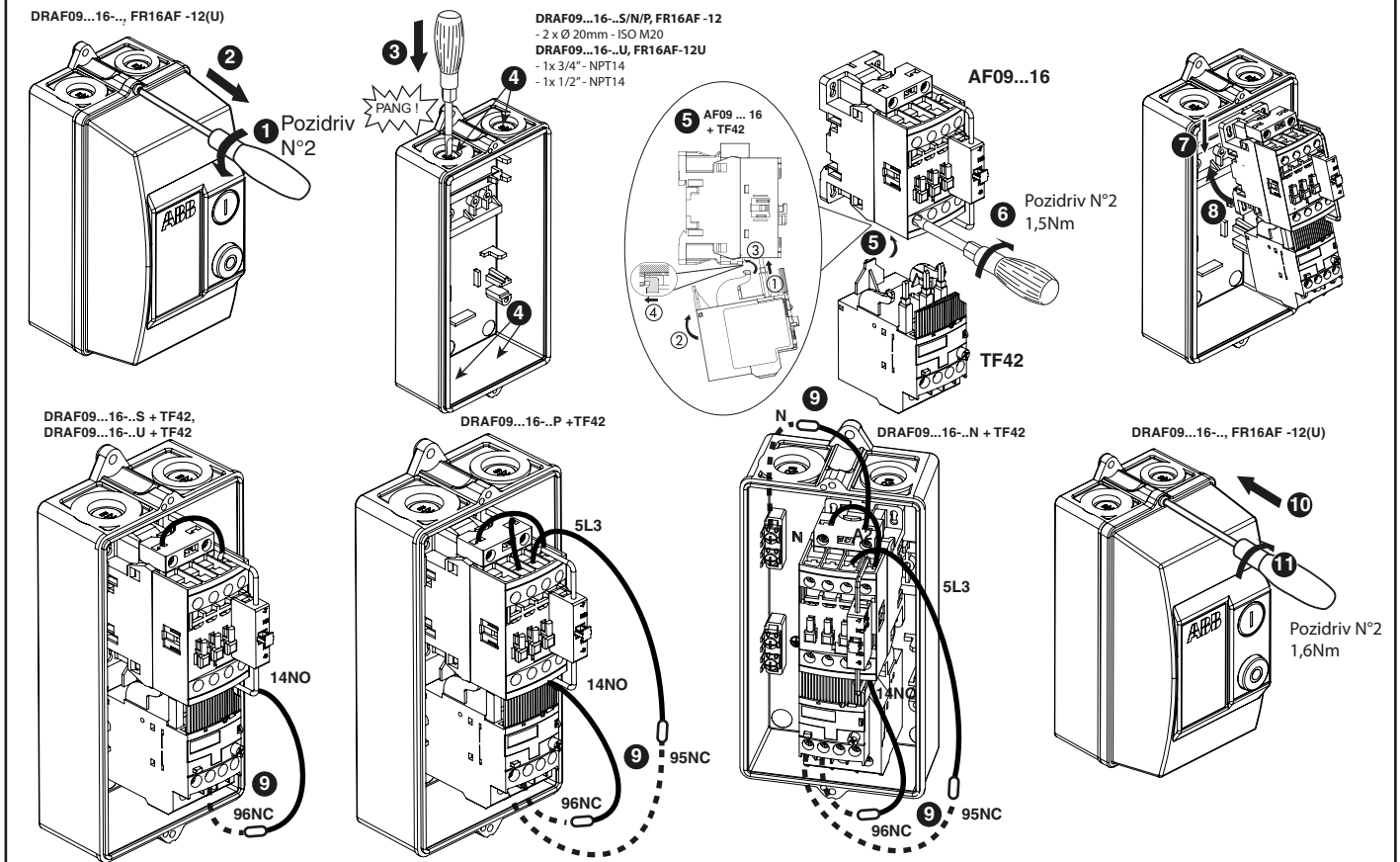
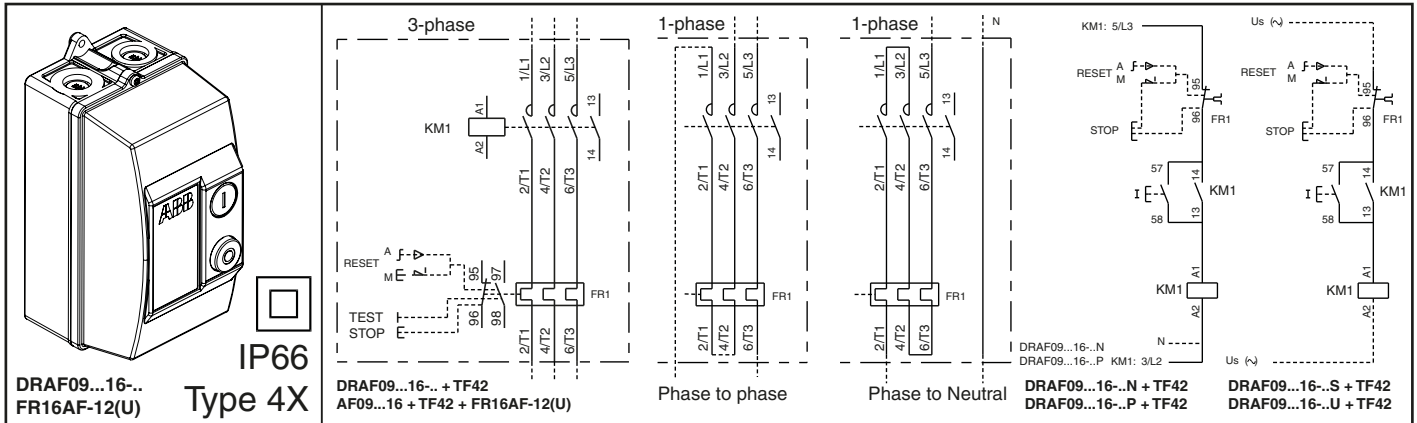

AF09 ... AF16	M 3,5 1,5Nm	Ø 5,5 mm	mm ² 2 x 1...6 AWG16-10 (str/sol)	mm ² 2 x 0,75...6	mm ² 2 x 0,75...2,5 1 x 0,75...4	mm L < 9,6	
	M 3,5 1,2Nm		2 x 1...2,5 AWG18-14 (str/sol)	2 x 0,75...2,5	2 x 0,75...1,5 1 x 0,75...2,5	L < 9,6 L < 8	
N PE	M4 1,8Nm	Ø 6,5 mm	2 x 1...6 AWG16-10	2 x 0,75...6	2 x 0,75...2,5 1 x 0,75...4	L < 8,8	

TF42 < 20A 2T1-4T2-6T3	M4 1,5... 2,5Nm	Ø 6,5 mm	mm ² 2 x 0,75...4 AWG18-10 (str/sol)	mm ² 2 x 0,75...4	mm ² 2 x 0,75...4	mm L < 12	
95-96 97-98	M3 1... 1,5Nm	Ø 5,5 mm	2 x 0,75...4 AWG18-12 (str/sol)	2 x 0,75...2,5	1x 0,75...2,5 2x 0,75...1,5	L < 9	

ABB France

3, rue Jean Perrin - CS90009
 F-69687 Chassieu cedex / France
 www.abb.com/contacts



- 1...6 DRAF09/12/16..S
- 1...6 DRAF09/12/16..U
- 1...6 DRAF09/12/16..N
- 1...6 DRAF09/12/16..P
- 1...4 FR16AF-12(U)
- 5 AF09/12/16-30-10
- 6 CB5-10
- 7 TF42DU
- 8 CA4-10, CA4-01, CC4-10, CC4-01

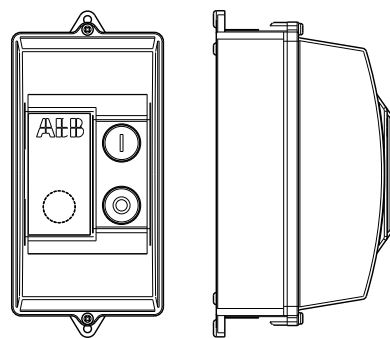
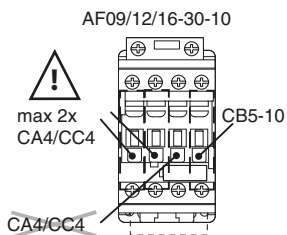

DRAF09/12/16..U
FR16AF-12U

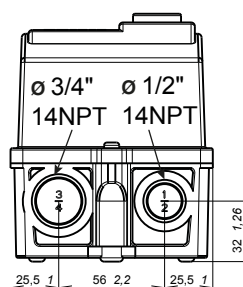

CA4-10							
CC4-10	M 3,5	ø 5,5	pozitiv	2 x	2 x	2 x	L = 9mm
CA4-01	1,2 N.m	mm	N° 2	1...2,5	0,75...2,5	0,75...1,5	
CC4-01						1 x	L < 8 mm
						0,75...2,5	

accessories - Zubehör - accessoires - tillbehör - accessori - accesorios - 及附件 - аксессуары
 Assembly - Anbau - Montage - Monterung - Montaggio - Montaje - 安裝 - Монтаж

Disassembly - Abbau - Démontage - Demontering - Smontaggio - Desmontaje - 拆卸 - Демонтаж

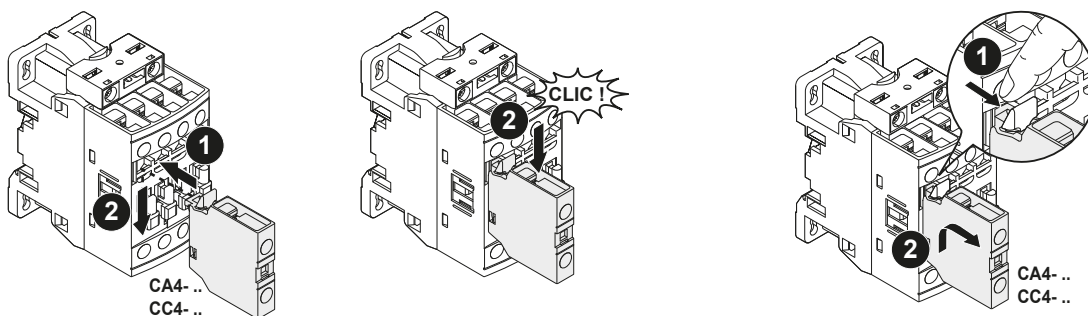

According to UL60947-4-1, for use on a circuit capable of delivering not more than the max. symmetrical amperes at 600V max. as shown in the tables below.
 WARNING : if opening of BCP, controller shall be examined and replaced if damaged.

Max Short Circuit 100kA at 600V	TF42-... max. A	max Fuse A/Class
DRAF09	16	30/J
DRAF12	16	30/J
DRAF16	20	60/J

Hub shall be connected to the conduit before the hub is connected to the enclosure.
 The conduit hub shall be marked as suitable for type 4.
 Bonding between conduit connections is not automatic and must be provided as a part of the installation.

Max Short Circuit 5kA at 600V	TOL relay	Type	Listed Circuit Breaker max. A
DRAF09 DRAF12 DRAF16	TF42-...	-0,13 -1,7	3
DRAF09 DRAF12 DRAF16	TF42-...	-2,3 -13	25
DRAF09 DRAF12 DRAF16	TF42-...	-16	50
DRAF16	TF42-...	-20	50

Warning ! The operation, installation and servicing of this appliance must be carried out by a qualified electrician applying the relevant rules of the art, installation standards and safety regulations. Before operating the contactors, check that control voltage complies with the data of the coil. Connection to other control voltage can destroy the coil. Do not touch live parts. Danger !
Warnung ! Die Inbetriebnahme und die Installation des vorhandenen Gerätes sowie jegliche Wartungsarbeiten müssen durch einen Fachelektriker, der die anerkannten technischen Regeln, die Montagevorschriften und die Sicherheitsvorschriften beachtet, durchgeführt werden. Vor Inbetriebnahme der Schütze prüfen ob Steuerspannung am Verwendungsort mit den aufgedruckten Spulendaten übereinstimmt. Der Anschluss einer anderen Steuerspannung kann zur Zerstörung der Spule führen. Spannung führende Teile nicht berühren. Lebensgefahr !
Attention ! La mise en œuvre, l'installation de cet appareil et toute intervention doivent être effectuées par un électricien professionnel appliquant les règles de l'art, les normes d'installation et les règlements de sécurité. Avant la mise en marche des contacteurs, vérifiez que la tension du circuit de contrôle correspond bien aux indications de la bobine. Le raccordement d'une tension différente peut mener à une destruction de la bobine. Ne pas toucher les pièces sous tension. Danger de mort !
Varning ! Igångsättning och installation av apparaten samt alla ingrepp bör utföras av en kompetent elektriker enligt gällande installationsnormer och säkerhetsregler. Kontrollera före installation av kontaktorn att aktuell manöverspänning överensstämmer med spolens märkdata. Felaktig manöverspänning kan skada spolen. Beröring av spänningsförande delar är förenat med livsfara.
Attenzione ! La messa in opera, l'installazione di questo apparecchio ed ogni tipo di intervento devono essere effettuati da un elettricista professionista il quale applichi le regole del mestiere, le norme di installazione ed i regolamenti di sicurezza. Prima della messa in servizio del contattore, verificare che la tensione del circuito di comando corrisponda esattamente a quella indicata sulla bobina. L'alimentazione con una tensione diversa, può provocare la distruzione della bobina. Non toccare le parti attive. Pericolo di vita !
Atención ! La puesta en aplicación, la instalación de este aparato y cualquier intervención deben realizarse por un electricista profesional que aplique las reglas del oficio, las normas de instalaciones y la reglamentación de seguridad. Antes de la puesta en servicio del contactor, comprobar si coinciden la tensión de mando con los datos impresos en la bobina. La conexión de otra tensión de mando puede producir la destrucción de la bobina. Las partes bajo tensión no deben tocarse. Peligro de muerte !
警告! 产品安装、操作、维修必须由具备资质的专业电工遵照相关制度、法规、安装标准及安全规范完成。接触器通电操作前，必须检查接入控制线圈的供电电源的实际电压。务必不要触及带电部件，危险！
Предупреждение! Ввод в эксплуатацию, обслуживание и сервисные работы на оборудование должны производиться квалифицированным персоналом в соответствии с национальными стандартами и требованиями безопасности. Перед началом эксплуатации проверьте соответствие напряжения управления с данными катушки. Подключение несоответствующего напряжения может вывести из строя катушку управления. Не дотрагивайтесь до токоведущих частей. Опасно!