

FurseWELD

Cable to reinforcing bar CRE1

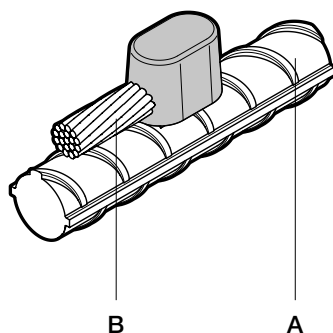

Cable to reinforcing bar CRE1 - FurseWELD

Reinforcing bar size A ø (mm ²)	Stranded/ solid circular conductor size B (mm)	Part no.			
		Powder cartridge	Standard mould	Handle clamp	Packing
10-40	16 *	45P10	CRE1-3-16	HCPK3-B	PACK-A
10-40	25	45P10	CRE1-3-25	HCPK3-B	PACK-A
10-40	35	45P10	CRE1-3-35	HCPK3-B	PACK-A
10-40	Ø 8	90P10	CRE1-3-8SC	HCPK3-B	PACK-A
10-40	50	90P10	CRE1-3-50	HCPK3-B	PACK-A
10-40	Ø 10	90P10	CRE1-3-10SC	HCPK3-B	PACK-A
10-40	70	90P10	CRE1-3-70	HCPK3-B	PACK-A
10-40	95	90P10	CRE1-3-95	HCPK3-B	PACK-A
10-40	120	90P10	CRE1-3-120	HCPK3-B	PACK-A

Special moulds for all FurseWELD products can be manufactured to meet specific customer applications on request
 *1 x S103 Sleeve required when joining conductors 16 mm² or smaller