

1-2 July 2015

Technical Paper

Optimizing Gas Storage Fields Operation through High Accuracy Multiphase Flow Metering

Nunzio Bonavita, ABB SpA
Paolo Ciandri, Tea Sistemi SpA
Gregorio Ciarlo, ABB SpA

1 INTRODUCTION

Natural gas consumption is far from being constant over the months. Typically Natural Gas (NG) is stored in summer periods, when there is lower demand for it, and is withdrawn in the winter periods, when significant amounts of NG are used for heating. Reserves smooth seasonal peaks and short-term peaks of NG consumption. This makes gas storage quite a clever and profitable business because of the related social and economic benefits, which include:

- Balancing of the gas supply and demand over a defined period such as
 - To compensate season-related fluctuations (summer / winter periods)
 - To ensure that natural gas is available without delay for diverse consumers
- Providing gas to the customers under optimum economic conditions between buying and selling
- Ensuring gas supply in the event of failures or malfunctions at production sites or in transportation systems.

Underground Gas Storage (UGS) is the most advantageous option for storing large volumes of gas.

UGS can take place in three different environment [1]:

- Depleted reservoirs, i.e. underground formations that originally contained and produced oil, natural gas or both. They are the most common solution representing around 75% of the world gas storage sites;
- Aquifers, i.e. underground, porous, permeable rock formations that are transformed from water reservoirs into gas reservoirs. They are the most expensive alternative and are used only when no depleted reservoir is available. They represent no more than 10% of the world UGS sites.
- Salt caverns, i.e. underground salt formations, which must be mined to create the containment volume. Usually they are much smaller than depleted reservoirs but, because of much higher rates of injection and withdrawal, they can be cycled several times a year so providing an ideal solution for peak load storage. They represent around 15% of the total number of sites but they are gaining shares because of their greater deliverability, which matches increasing market demand of flexibility.

According to Enerdata [2], global gas storage capacity is expected to increase from 377 billion cubic meters (bcm) at the beginning of 2013 to 557-631 bcm by 2030.

1-2 July 2015

Technical Paper

The incremental growth is requiring and will require continuous investment all over the period that is estimated in about €120 billion by 2030.

The growth will be stronger in emerging gas market, like China, and will benefit from market liberalization, because of the inherent commercial value of UGS as a key supporting role for gas trading. Additionally, in mature markets like Europe and North America, UGS will play an increasing role as back-up of erratic renewable energy sources.

2 GAS STORAGE FIELD OPERATIONS AND POSSIBLE IMPROVEMENTS

A UGS processing facilities is designed in order to operate in two main modes:

- a. Gas injection
- b. Gas extraction

During the gas injection phase (blue path on the left-hand side in Figure 1), the dry gas is extracted from the pipeline and, after its flowrate has been accurately measured by conventional gas meters, it is delivered to one of the several compressors present at the site. Scope of the compressors is to provide the boost able to rise gas pressure from 7-8 MPa, which are the typical values for distribution pipelines, up to 20 MPa range, which represents the allowable pressure of stored gas. After proper cooling the gas is finally injected into a number of wells. The same wells will be later used during the withdrawal phase when the site is in production mode and gas is extracted and supplied back into the distribution pipeline (green path on the right-hand side in Figure 1).

However, the natural gas supplied back to the grid has to meet all requirements of the applicable standards (e.g. DVGW standard G 260) for marketable natural gas: in particular, it has to be clean and dry. Unfortunately, during the storage period the original high quality, dry gas could become contaminated by both water and (especially in depleted reservoirs) heavy hydrocarbons. The directive for gas distribution sets the allowable concentration of water and concentration of higher hydrocarbons. In the US and Canada, the amount of allowable water in the gas is equivalent to 0,112 gH₂O/Sm³. In Europe, the concentration of water and higher hydrocarbons is specified by their dew point temperature (T_{dew}) and is equivalent to roughly 0,131 gH₂O/Sm³ of NG at 4 MPa. The average value of water in NG withdrawn from UGS is 2 - 5 times higher than required [3].

For this reason, before delivering the gas to the market, UGS operators must afford additional gas processing, like injection of inhibitors (to prevent the formation of hydrates) and, above all, proper removal of free liquids and gas dehydration. Removal of free liquids and gas dehydration represent key and expensive steps in any UGS site. While removal of free liquids is mainly performed through bi-phase separators, usually dehydration may happens through a few alternative processes, like:

- Absorption, where a special chemical (triethylene glycol – TEG) is used in counterflow to extract water from NG in a tray column or packed bed.
- Adsorption, where H₂O is removed exploiting a solid desiccant (silica gel or alumina) in parallel adsorption beds.
- Condensation, where the gas is cooled down until H₂O traces are turned into liquid phase and removed.

1-2 July 2015

Technical Paper

All three methodologies present advantages and disadvantages, which have been extensively analyzed in industry and academia [3] but they definitively represent an energy consumption and therefore an operative cost which affects UGS operation and balance sheets.

However, it should be noted that the role of free liquid is critical because if free liquid suddenly increases in an extraction well, separator could not be able to manage it and flood the dehydration column, preventing the possibility to deliver NG at the law-enforced specification.

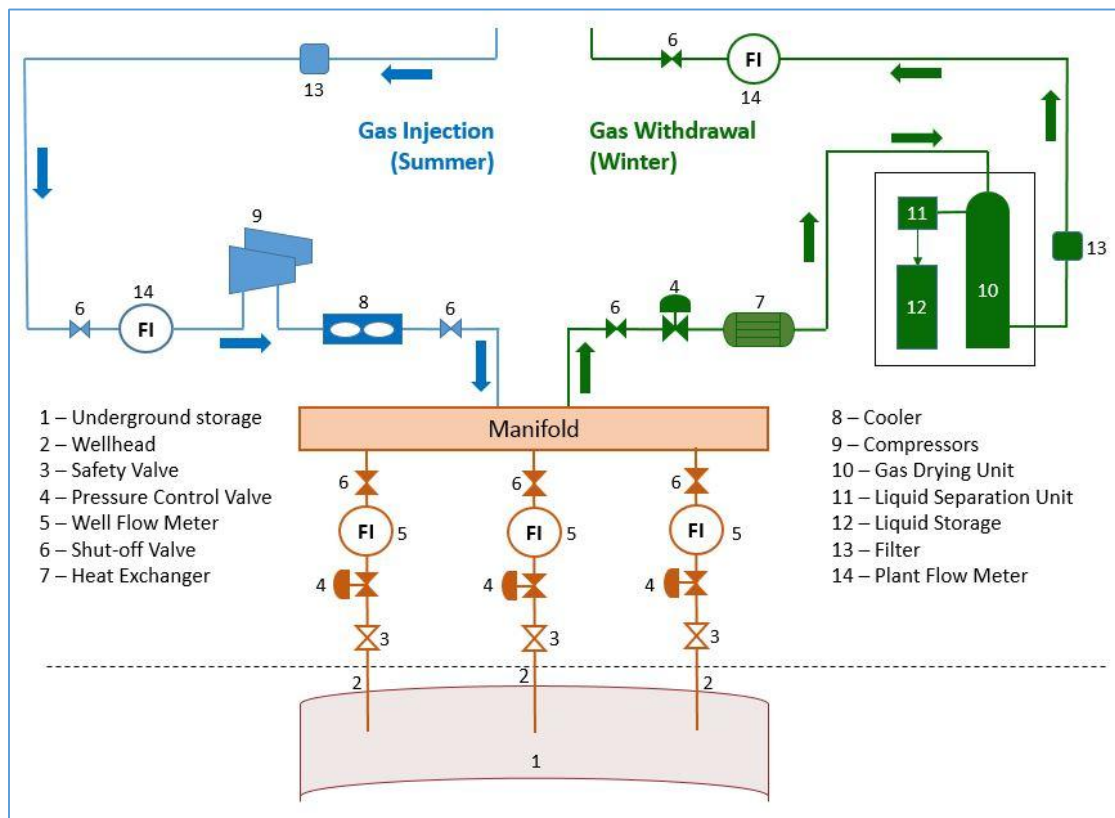

Figure 1 - UGS Surface Facilities Basic Schematics

Being able to measure on-line free liquid in withdrawn gas would therefore provide a number of operative benefits:

- Optimizing gas dehydration stage, tailoring the effort to the real need and saving money spent in overprocessing the gas;
- Reducing environmental impact: US Environmental Protection Agency (EPA) estimates that 17 BCF of methane are lost each year through dehydration and pump inefficiencies: because methane emissions are directly proportional to glycol presence, adjusting water adsorption to the actual needs would definitively cut the methane emissions at the root;
- Monitoring wells behavior in order to perform proper well allocation during the extraction stage. Because of local differences in porosity and permeability, water may affect differently wells extracting gas from the

1-2 July 2015

Technical Paper

same depleted reservoir. Knowing how much water is contaminating each extraction well would allow a proper management of the site, maximizing withdrawal from good wells and minimizing (or even shutting down) poor performing ones.

Regrettably, these advantages have not yet been pursued because of the inherent difficulty in measuring on-line minimal traces of liquid in gas.

3 AN INNOVATIVE MULTIPHASE FLOW METER

ABB VIS (Vega Isokinetic Sampling) is the new multiphase flowmeter whose specific design and characteristics make it perfectly suited for gas storage applications. As the acronym reveals, VIS has its roots in former TEA Sistemi's Vega meter, developed and successfully installed in more than 40 applications worldwide from the beginning of 2000s.

The new multiphase flowmeter, although it is based on the same working principle – the isokinetic sampling – involves a complete redesign of the meter in order to minimize its weight and footprint [4]:



Figure 2 – The new VIS multiphase flowmeter

The result is a much more compact meter, able to provide the same accuracy of the previous version.

Figure 3 provides a schematic of the new VIS meter design and main components. In VIS meter the flow is directed downward and a small part of the fluid is sampled, fed to the gas liquid separator and then re-injected into the main pipe, downstream the multiphase orifice [5]. Sampling is performed by means of a special-design multi-port probe in a section of the pipe where the phase velocities and concentrations are uniform.

1-2 July 2015

Technical Paper

Inside the gas liquid separator, the different phase of the samples are separated and further liquid traces entrained in the gas are removed by the swirl separators included at the top of the meter.

Gas flow rate is measured before the re-injection with conventional ΔP meter (e.g. typically a Venturi meter), while the sampled liquid flow rate is computed from the time required to fill a known volume of the separator itself. The determination of the fill-up time is performed with differential pressure transmitters that measure the static head at different positions of the gas-liquid separator.

Once the liquid reaches a predefined value, the liquid discharge valve opens allowing the reinjection of the liquid phase in the main pipe. After the complete removal of the liquid phase from the body of the meter, the valve is closed and the measurement cycle starts again.

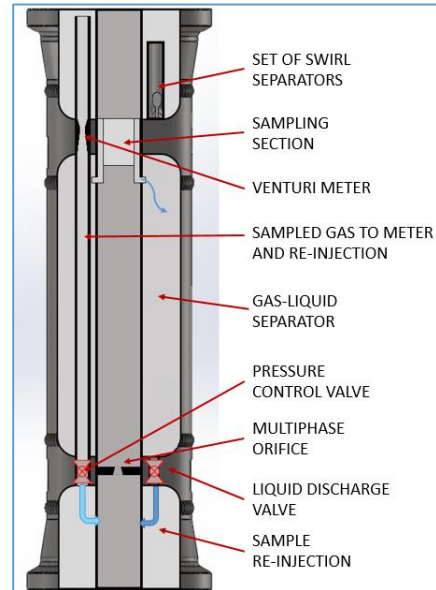

Figure 3 - VIS meter main components

3.1 Technology Description – Isokinetic Sampling

In simple words, VIS multiphase flowmeters derives the different phased flowrates basing on their values in the samples extracted through the probe. The crucial requirement is that those samples are 100% representative of flow characteristic in the main pipe.

The isokinetic sampling method, VIS operating principle, allows the extraction of samples from the main flow without modifying the flow field around the probe. Therefore if the probe is installed in a proper section where the velocity profiles of the gas and the liquid phase are uniform (note that mean gas and liquid velocities can be different), this technique grants that sampled portions are fully representative of the main flow.

Isokinetic sampling conditions are established within the meter by setting the pressure control valve at such a position that the ratio between pressure drops through the multiphase orifice in presence of sampling, $\Delta p_{TP,S}$ and without sampling Δp_{TP} , be equal to [6]:

$$\frac{\Delta p_{TP,S}}{\Delta p_{TP}} = (1 - r_A)^2 \quad (1)$$

Where r_A is defined as the sampling ratio, which is equal to ratio between the main pipe at the sampling section and the sampling probe section:

$$r_A = \frac{A_p}{A_s} \quad (2)$$

1-2 July 2015

Technical Paper

From the equation modeling the flow through an orifice plate, combined with the previous expression, it is also possible to derive that:

$$\frac{\Delta p_{TP,S}}{\Delta p_{TP}} = \left(1 - \frac{q_G}{Q_G}\right)^2 \quad (3)$$

Where, q_G is the gas flow rate in the sample and Q_G is the total gas flow rate through the orifice.

This means that when sampling is isokinetic the ratio between the sampled gas flow rate and the total gas flowrate is equal to the sampling ratio; $q_G/Q_G = r_A$. A similar expression holds for the liquid, even in the case the sampling is not perfectly isokinetic, if the liquid distribution and velocities are uniform at the sampling section.

Since r_A is a known parameter depending only on the geometry of the meter, the overall gas and liquid flow rate can be easily derived, dividing the flow values from the samples by the sampling ratio:

$$Q_G = q_G / r_A \quad (4)$$

$$Q_L = q_L / r_A \quad (5)$$

3.2 VIS for Gas Storage applications

VIS technology has proved to be able to provide high performances even in the most challenging conditions, i.e. when Gas Volume Fraction (GVF) is extremely high exceeding 98% and even 99% [7]. Actually, VIS has proved to be able to detect even minimal traces of liquid into gas and this obviously spurred the interest in testing it for gas storage applications.

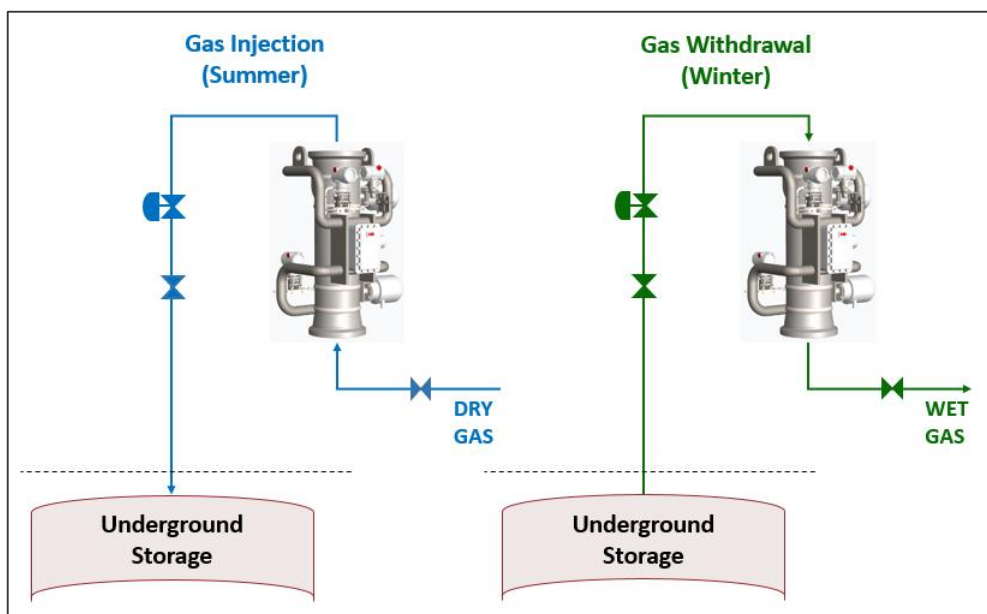

Figure 4 – Schematic of VIS installation at GS fields

1-2 July 2015

Technical Paper

Additionally, VIS internal design is perfectly suited for gas storage applications, being able to cover the two different operating conditions:

- During gas injection, VIS provides a measurement of the dry gas by means of the internal orifice plate;
- During gas withdrawal, VIS works as a true multiphase flowmeter, providing not only the extracted gas flow but also a measurement for the free liquid.

It should be noted that VIS acts as a standard orifice-plate flowmeter during the gas injection (i.e. dry gas) operation while providing the multiphase metering capability during the gas withdrawal one, when liquid contaminants have to be detected. This remarkable bi-directional functionality will be assured by employing an orifice plate with the same edge design in both directions.

The result is quite relevant from operational and investment standpoint: in fact, VIS actually replaces the conventional flowmeter (orifice plate or ultrasound) rather than to be added to present process configuration, enhancing information and monitoring while preserving footprint requirement.

4 FIELD EXPERIENCES

Applications of multiphase flowmetering to detect minimum amount of liquid contaminants in gas is not very common due to the extreme sensitivities requested to the devices. Authors have not been able to detect in literature any report of other conventional multiphase flowmeters able to achieve the extremely demanding requirements placed by UGS applications. Isokinetic sampling seems to be the most effective technology as proved in several field applications by the Vega meter starting from 2007.

The first extremely high GVF commercial installation is related to the measurement of the liquid carry-over from a dehydration column operated by STOGIT, in Ripalta, Italy [6]. In order to properly assess the isokinetic sampling technology actual performances, the VEGA meter was installed downstream the dehydration column, where, just for experimental purposes, a small pump injected predefined quantities of TEG into the dry gas (Figure 5). The meter reading could be therefore compared with the known amounts of injected liquid, resulting in an effective and valid assessing procedure.

The test application presented an additional quite relevant complication. In fact, because of installation and logistics constraints, the meter had to be specifically designed in a very special set-up, which, among others, required a horizontal configuration. Horizontal configuration is very unfavorable because gravity alters the ideal homogeneous flow easing phase stratification, i.e. moving away from ideal isokinetic conditions.

Additional compensations and ad-hoc calibrations were therefore requested just because of the horizontal design. When measuring extremely low liquid volume fractions, like in Ripalta installations, the accuracy of liquid flow rate measurements largely relies upon a complete separation of fine droplets entrained by the gas. In order to achieve complete separation of the entrained liquid, a novel designed swirl separator had to be developed. The geometry of this separator was optimized with

1-2 July 2015

Technical Paper

a 3-D simulation of the flow field and the final geometry was tested in a set of laboratory experiments that indicated that the separation efficiency of droplets with diameter $\leq 5 \mu\text{m}$ was better than 99%.

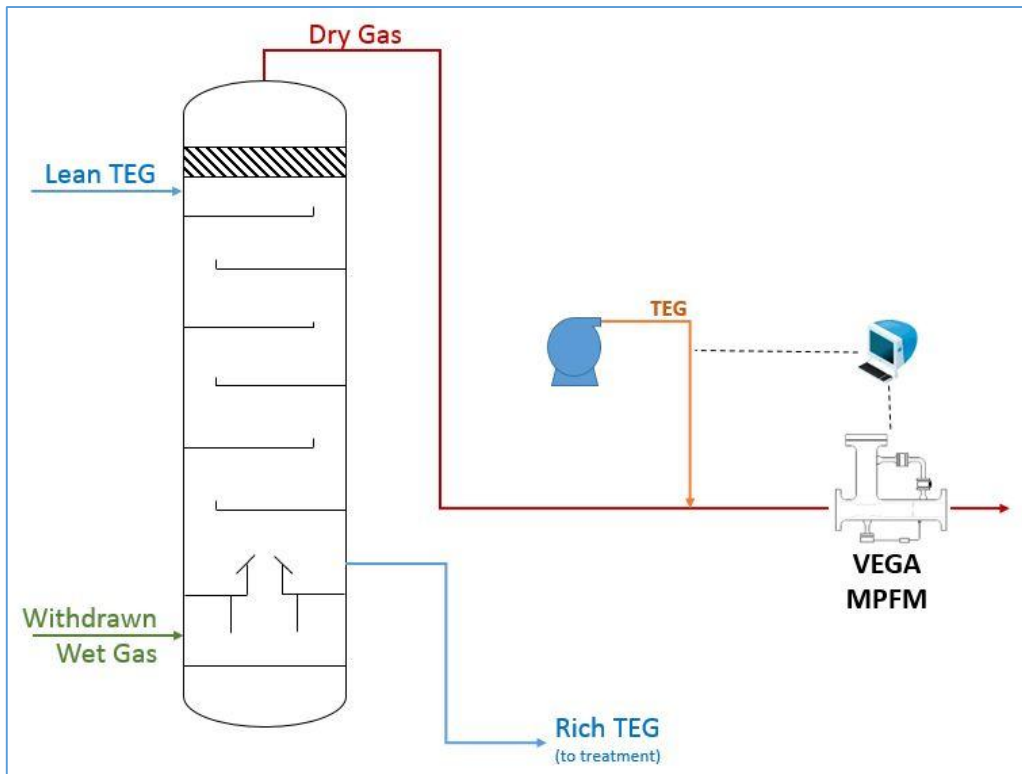

Figure 5 – Ripalta MPFM Test set-up

This was not the only challenge: the pipe diameter in that application was extremely large (12"), well above the typical multiphase meter size.

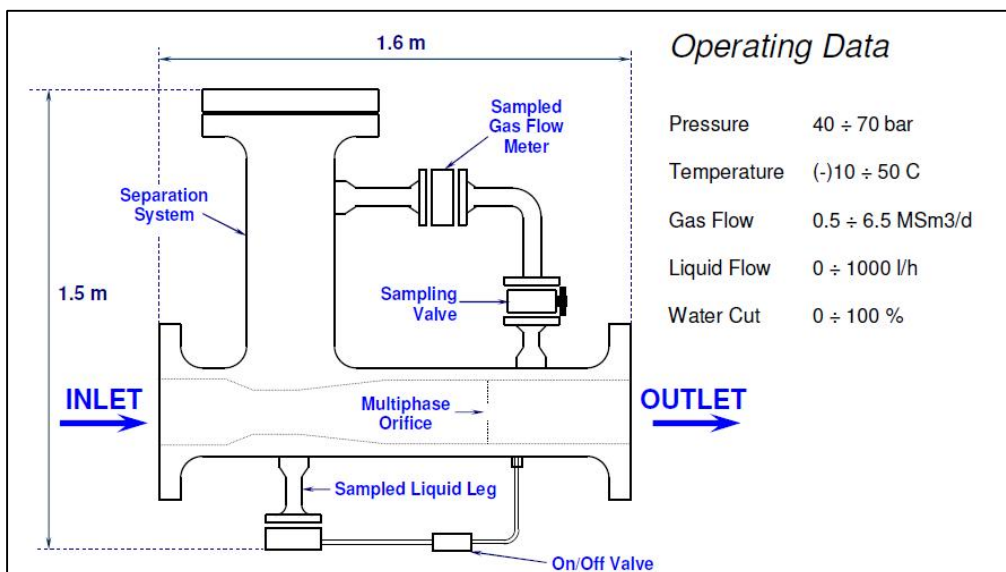

Figure 6 - Schematic of the Ripalta horizontal meter

1-2 July 2015

Technical Paper

These constraints and the extremely low minimum Liquid Void Fraction (LVF) to be detected (set to 2.0×10^{-4} %) caused an expected accuracy of 10% of the actual liquid flow rate, which is definitively higher than the typical performances.

Table I reports the results performed on the Ripalta meter: it should be noted that, notwithstanding the extremely severe installation conditions, at intermediate velocities the error is about zero and also that it seems very easy to suppress the errors and to fulfil the requirement of keeping the uncertainty of these measurements below 10% after field calibration.

Table 1 – Results of Ripalta installation

Test [n]	Press. [Bar.g]	T [°C]	Ref. Gas Flow [KSm ³ /h]	Meter Gas Flow [KSm ³ /h]	Gas Flow Error [%]	Inject. TEG [l/h]	LVF [%]	Meter Correct Liquid [l/h]	Liquid Flow Error [%]
1	55.6	-3.8	188	185	-1.3	16	4.74E-04	14.5	-9.1
2	55.7	-3.2	250	251	0.4	14	3.12E-04	15.2	8.6
3	55.4	-3.0	250	249	-0.4	18	3.99E-04	19.7	9.4
4	56.4	-2.3	250	252	0.8	20	4.51E-04	18.4	-8.2
5	58.9	-1.4	83.3	84	0.8	10.5	7.42E-04	9.8	-7.0
6	59.7	-0.1	83.3	83	-0.4	19	1.36E-03	21.3	12.1
7	58.0	-0.6	170	173	1.8	34	1.16E-03	32.2	-5.3



Figure 7 – Isokinetic Sampling-based MPFM installation in Ripalta

The results proved the potentiality of the isokinetic sampling technology and provided the basis for installing the normal, vertical downward flowing meters at the exit of extraction wells in several locations. Removing the gravity-bias resulted

1-2 July 2015

Technical Paper

in achieving the normal accuracy levels typical of such technology (3% for gas and 5% of liquid measurements) also for gas storage applications.

5 NOTATION

$\Delta p_{TP,S}$	Pressure drop through multiphase orifice in presence of sampling	q_G	Gas flowrate in the sample
Δp_{TP}	Pressure drop through multiphase orifice with no sampling	Q_G	Gas flowrate through the orifice
A_p	Pipe section area	q_L	Liquid flowrate in the sample
A_s	Sampling probe section area	Q_L	Liquid flowrate through the orifice
		r_A	Sampling ratio

6 REFERENCES

- [1] Gas Storage Industry Primer, <http://www.niskapartners.com/wp-content/uploads/2010/04/GasStorageIndustryPrimer.pdf>
- [2] Underground World Gas Storage, World Gas Storage Publication - 5th edition 2013, Cedigaz Publisher
- [3] M. NETUSIL, P. DITL, Comparison of three methods for natural gas dehydration, Journal of Natural Gas Chemistry 20 (2011) pp. 471-476
- [4] P. ANDREUSSI, P. CIANDRI, N. BONAVIDA, G. CIARLO (2014) "Wet Gas Metering by Isokinetic Sampling", Proc. of: "13th International Conf. on Multiphase Flow in Industrial Plants", 17-19 Sept. 2014, Sestri Levante (Italy)
- [5] P. ANDREUSSI, P. CIANDRI, and V. FALUOMI, (2003). Development of a Wet Gas Flowmeter. *Multiphase Production*. BHR, London.
- [6] P. ANDREUSSI, P. CIANDRI, S. BOSCHI, G. TAGLIAFERRI, M. and BAVA, (2007) "Application of a Wet Gas Meter to Detect Extremely Low Liquid Volume Fractions" *Multiphase Production*. BHR, London.
- [7] G. FALCONE, G.F. HEWITT, A. ALIMONTI, (2010) "Multiphase Flow Metering: Principles and Applications", Elsevier