

ACS 160

**Installation and
Start-up Guide**

RS485 and RS232
Adapter Module CFB-RS



RS485 and RS232
Adapter Module CFB-RS

**Installation and
Start-up Guide**

3BFE 64390431 R0125
EN
EFFECTIVE: 23.3.2001

Safety Instructions

Overview

This chapter states the safety instructions that must be followed when installing and operating the RS485/RS232 adapter. If neglected, physical injury and death may follow, or damage may occur to the frequency converter, the motor and driven equipment. The material in this chapter must be studied before attempting any work on, or with, the unit.

Warnings

Warnings are used to inform of conditions which can, if proper steps are not taken, lead to a serious fault condition, physical injury and death.

Readers are informed of situations that can result in serious physical injury and/or serious damage to equipment with the following symbols:



Dangerous Voltage Warning: warns of situations in which a high voltage can cause physical injury and/or damage equipment. The text next to this symbol describes ways to avoid the danger.



General Warning: warns of situations which can cause physical injury and/or damage equipment by means other than electrical. The text next to this symbol describes ways to avoid the danger.

Safety Instructions

Table of Contents

Safety Instructions

Overview	i
Warnings	i

Chapter 1 – Introduction

Overview	1-1
Delivery Check	1-1
How to Use This Guide	1-1

Chapter 2 – Installation

Mounting	2-2
Connectors and Switches	2-3
Selecting the Communication Speed	2-4
Selecting RS485 or RS232 Mode	2-5
RS485 Bus Termination	2-5
Installation to RS485 Bus	2-6
Installation to RS232 Bus	2-8
Earthing and Termination	2-11

Chapter 3 – Programming

General	3-1
Communication Settings	3-2
Control Locations	3-5
Diagnostic Counters	3-6

Chapter 4 – Communication

Introduction to Modbus	4-1
Register Read and Write	4-1
Register Mapping	4-2
Exception Codes	4-3
Function Codes	4-4
The Control Word and the Status Word	4-4

References.....	4-8
Actual Values	4-11
Fault and Alarm Status	4-13

Chapter 5 – Fault Tracing

Appendix A – Parameter Scaling

Effect of Resolution	A-1
Signed Values	A-1

Appendix B– Technical Data

RS-485 Link	B-1
CFB-RS.....	B-1

Appendix C– Ambient Conditions

Operation	C-1
Storage and Transportation	C-1

Chapter 1 –Introduction

Overview

The RS485 and RS232 adapter is used for connecting the ACS 160 frequency converter to a serial Modbus (RS232 or RS485) network. The adapter is IP65 protected for use in demanding environmental conditions.

Delivery Check

The option package includes:

- RS485/RS232 Adapter
- Installation and Start-up Guide for RS485 and RS232 Adapter
- Two M16 x 1,5 cable glands with O-ring.
- Two M4 x 12 mounting screws

How to Use This Guide

The purpose of this Guide is to provide the information necessary to install, commission, use, and to fault diagnose the adapter.

Safety Instructions describe the formats for warnings and notations used within this guide. This chapter also states the safety instructions which apply to the installation and operation of the RS485/RS232 Adapter.

Chapter 1 – Introduction, the chapter you are reading now, contains a short description of this manual and a list of related publications.

Chapter 2 – Installation contains instructions for mechanical and electrical installation of the adapter.

Chapter 3 – Programming explains how to program the ACS 160 drive for Modbus communication.

Chapter 4 – Communication describes the Modbus communication on ACS 160 drives.

Chapter 5 – Fault Tracing describes how to diagnose the most common problems with the adapter.

Chapter 1 –Introduction

Appendix A– Parameter Scaling describes the scaling when parameters are accessed through the Modbus network.

Appendix B– Technical data of the module.

Appendix C– Ambient conditions.

Conventions Used in This Guide

This manual uses some terms and conventions which might not be known to every user of this manual. Some of these terms are described below.

4XXXX Register Area

Modicon PLCs have a signed integer data table area, which is used for Analogue Output modules and for storing temporary or set-point values. These registers are in the address area starting from 40001. The last register address available on PLCs depends on the available memory, but is less than 49999.

The ACS 160 drive simulates this area by providing a read and write access to its parameters through this register address area.

Related Publications

ACS 160 User's Manual.

Chapter 2 – Installation

This chapter contains instructions for setting up the RS485/RS232 adapter.



WARNING! Verify that the ACS 160 is not powered before starting the installation. Follow the safety instructions given in this Guide and in the ACS 160 User's Manual.

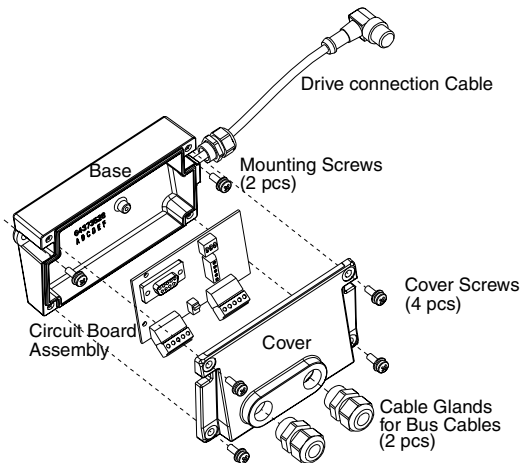

Figure 2-1 Exploded view of the CFB-RS Adapter Module

Mounting

The CFB-RS can be mounted onto the ACS 160 drive with two screws as shown in the ACS 160 User's Manual. This also provides the earthing of the module housing.

The CFB-RS uses the control panel connector of the drive. The CFB-RS is powered through this connector.

The CFB-RS provides two cable entries for the incoming and outgoing bus cables. The cables are connected to a detachable terminal header.

If only one bus cable is connected, the unused cable entry should be plugged.

Remove the front cover to access the configuration switches and jumpers.

Connectors and Switches

The adapter operates either in RS232 mode or RS485 mode. The mode can be selected with a jumper. By default, the adapter operates in RS485 mode at a communication speed of 9600 bps (bits per second).

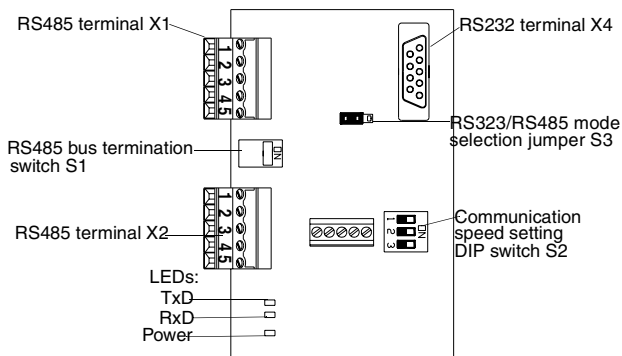

Figure 2-2 Connectors and switches.

Selecting the Communication Speed

Communication speed is selected by DIP switch S2 and by parameter 5201 COMM SPEED. The factory setting for the communication speed is 9600 bps (bits per second).

Communication speed setting using DIP switch S2 is needed only when the adapter operates in RS485 mode.

DIP switch S2 Communication speed







	300 bps
	600 bps
	1200 bps
	2400 bps
	4800 bps
	9600 bps
	19200 bps

Figure 2-3 Selecting the communication speed for the adapter.

Selecting RS485 or RS232 Mode

The adapter operates either in RS232 mode or in RS485 mode, selectable by a jumper. As a factory setting, the adapter operates in RS485 mode.

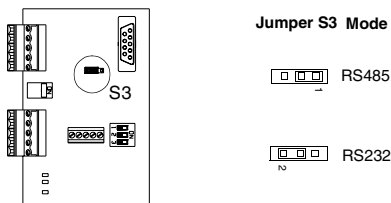

Figure 2-4 Selecting the operating mode.

RS485 Bus Termination

The RS485 bus must be terminated using 120 Ω resistors at both ends of the network. The adapter has built-in termination resistors that can be enabled by the bus termination switch S1. Refer to 'Earthing and Termination' on page 2-11. By default, bus termination is enabled (ON).

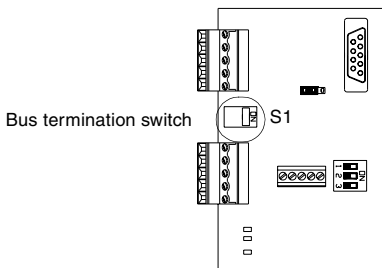

Figure 2-5 Selecting RS485 termination impedance.

Installation to RS485 Bus

- 1 Make sure power is not connected to the ACS 160.
- 2 Set the adapter switches:
 - Confirm that the operation mode is RS485 (jumper S3)
 - Set communication speed of the adapter with DIP switch S2
 - If the termination is not needed, use switch S1 to disable it.
- 3 Mount the adapter on the side of the ACS 160. Leave the drive connection cable disconnected.
- 4 Wire the adapter to the RS485 network (X1 and X2).
- 5 Connect the control panel to the drive.
- 6 Connect power to ACS 160.
- 7 Set up communication: Station number, communication speed of the drive and parity. Refer to Chapter 3 – Programming.
- 8 Set up other drive parameters as needed. Refer to ACS 160 User's Manual and Chapter 3 of this manual.
- 9 Disconnect power from the ACS 160.
- 10 Disconnect control panel and connect drive connection cable of the adapter.

Wiring

The RS485 link is a daisy-chained bus, without dropout lines. The RS485 link should also be terminated on both physical ends of the wire to reduce the noise on the network.

Modbus network should be wired using Belden 9841 or equivalent. Belden 9841 is a single twisted shielded pair cable with a wave impedance of 120 Ω .

The network should be connected according to Figure 2-6 below.

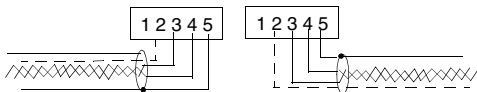

Figure 2-6 RS485 wiring.

Table 2-1 RS485 connection terminals. Terminals X1 and X2 are connected in parallel.

X1, X2		Description
1	-	No connection
2	C	Common. Connected to ACS 160 chassis through 100 Ω impedance
3	A	Data negative
4	B	Data positive
5	Shield	Cable shield

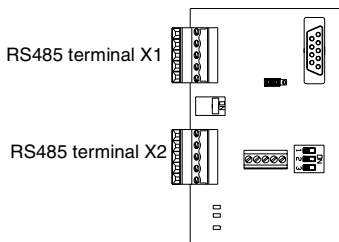

Figure 2-7 RS485 connection terminals X1 and X2.

Installation to RS232 Bus

- 1 Make sure power is not connected to the ACS 160.
- 2 Confirm that the operation mode is RS232 (jumper S3).
- 3 Mount the adapter on the side of the ACS 160.
- 4 Connect the control panel to the drive.*
- 5 Connect power to ACS 160. *
- 6 Set up communication: Station number, communication speed of the drive and parity. Refer to Chapter 3 – Programming. *
- 7 Set up other drive parameters as needed. Refer to ACS 160 User's Manual and Chapter 3 of this manual. *
- 8 Disconnect power from the ACS 160.
- 9 Disconnect control panel.
- 10 Connect drive connection cable of the adapter. Plug in the RS232 cable (X4).

* These steps can be ignored when using DriveWindow Light PC tool, or when the default communication settings are used.

Wiring

RS232 bus is a point-to-point type bus. Typical usage is to temporarily connect the drive into the serial port of a PC. Cover of the adapter module can not be closed when RS232 connector is used.

The maximum RS232 cable length is 3 meters. The RS232 cable is not included in the delivery.

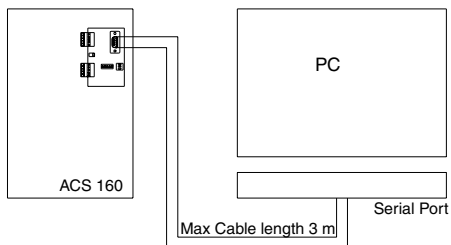
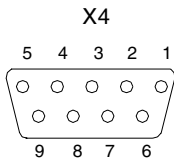

Figure 2-8 RS232 wiring.



X4		Description
1		NC
2		TxD
3		RxD
4		DTR
5		SGND
6		DSR
7		RTS
8		CTS
9		NC

Figure 2-9 RS232 signals. DTR and DSR as well as RTS and CTS signals are internally connected. The RS232 cable should not have TxD and RxD signals connected across.

Earthing and Termination

RS485 Bus

The RS485 network should not be directly earthed at any point. All the devices on the network should be well earthed using their corresponding earthing terminals.

As always, the earthing wires should not form any closed loops, and all the devices should be earthed to a common earth.

The RS485 network must be terminated using $120\ \Omega$ resistors at both ends of the network as shown in Figure 2-10. These resistors are already resident on the adapter. Use switch S1 to connect the termination resistors.



Figure 2-10 Termination for the RS485 link.



The connections may only be made with the drive disconnected from the power source.

Chapter 2 – Installation

Chapter 3 – Programming

This chapter describes how to program the ACS 160 drive for Modbus communication. The reader should be already familiar with programming the drive parameters using the control panel, and the way the parameters are arranged in groups. For details, see the ACS 160 User's Manual.

General

When power is connected, the ACS 160 will automatically check for the presence of the panel.

If the panel is NOT detected in 7 seconds after power up, the ACS 160 will set up Modbus communication normally, using the parameters 5201 STATION ID, 5202 COMM SPEED and 5203 PARITY. This communication setting is then used until the next power-down.

Note! If any of the parameters 5201 STATION ID, 5202 COMM SPEED and 5203 PARITY has been altered, the control panel will operate only if it is connected before the power is applied to the ACS 160 (or immediately after power-up).

Note! If any of the parameters 5201 STATION ID, 5202 COMM SPEED and 5203 PARITY is altered, the modification takes effect only on the next power-up, and if the control panel is not connected when the power is applied.

Communication Settings

The configuration information is in Group 52. The contents of this group are shown in Table 3-1 below.

Table 3-1 Communication parameters.

Code	Name	Range	Default	User
Group 52				
SERIAL COMM				
5201	STATION NUMBER	1 - 247	1	
5202	COMM SPEED	3 = 300 bps 6 = 600 bps 12 = 1200 bps 24 = 2400 bps 48 = 4800 bps 96 = 9600 bps 192 = 19200 bps	96 (9600 bps)	
5203	PARITY	0 - 2	0 (NONE)	
5204	COMM FAULT TIME	0.1 - 60.0 s	1.0 s	
5205	COMM FAULT FUNC	0 - 3	0 (NOT SEL)	

Code	Name
5201	<p>STATION NUMBER</p> <p>Sets the slave number for the ACS 160 in Modbus network. Range: 1 - 247</p> <p>Note! Modifications take effect only on the next power up.</p>
5202	<p>COMM SPEED</p> <p>Defines the communication speed of the ACS 160 in bits per second (bps).</p> <p style="text-align: center;">3 = 300 bps 48 = 4800 bps 6 = 600 bps 96 = 9600 bps 12 = 1200 bps 192 = 19200 bps 24 = 2400 bps</p> <p>Note! Modifications take effect only on the next power-up.</p>
5203	<p>PARITY</p> <p>Defines the parity to be used in Modbus communication. Parameter also defines the number of stop bits. In Modbus communication, the number of stop bits is 2 with no parity bit, and 1 with even or odd parity.</p> <p>0 = NONE 1 = EVEN 2 = ODD</p> <p>Note! Modifications take effect only on the next power-up.</p>
5204	<p>COMM FAULT TIME</p> <p>Time limit for communication loss detection. This parameter is used together with parameter 5205 COMM FAULT FUNC to define the ACS 160 operation when the communication with the master device in the Modbus network is lost.</p> <p>The master device in the Modbus network must signal its presence to every slave device (ACS 160) in the network by periodically writing Command Word, External Reference 1 or External Reference 2 to each ACS 160 in the network. Maximum write period is set by this parameter. Range: 0.1 - 60.0 s</p> <p>Note! During the first 4 seconds after power-up, communication fault is not evaluated to compensate for possible long system start-up delay.</p>

Code	Name
5205	<p>COMM FAULT FUNC</p> <p>Operation in case the communication with the master device is lost. The time limit for communication loss detection is set by parameter 5204 COMM FAULT TIME.</p> <p>0 = NOT SEL Communication loss is not detected.</p> <p>1 = FAULT A fault indication is shown on the control panel display and included in the Status Word. The ACS 160 coasts to stop.</p> <p>2 = CONST SPEED 7 A warning indication is shown on the control panel display and included in the Status Word. The speed reverts to the level set by parameter 1208 CONST SPEED 7.</p> <p>3 = LAST SPEED A warning indication is shown on the control panel display and included in the Status Word. The speed reverts to the level set by the current frequency reference.</p> <p> Warning! If CONST SPEED 7 or LAST SPEED is selected, ensure it is safe to continue operation in case communication with the master device fails.</p>

Control Locations

The ACS 160 drive can receive control signals from multiple sources (such as the digital and analogue inputs, the control panel, and a fieldbus adapter). The user can separately determine the source for each type of control information. Especially refer to parameter groups 10, 11 and 16 in the ACS 160 User's Manual for information on the selection parameters.

Diagnostic Counters

Diagnostic counters can be used for debugging the Modbus system.

Counters will roll over from 65535 to 0. The counter values are stored to permanent memory when power is disconnected.

Counters can be reset from the control panel by pressing the UP and DOWN buttons simultaneously when in parameter set mode, or by setting them to zero via the serial communication channel.

Code	Name	Range	User
Group 52			
SERIAL COMM			
5206	BAD MESSAGES	0 - 65535	
5207	GOOD MESSAGES	0 - 65535	
5208	BUFFER OVERRUNS	0 - 65535	
5209	FRAME ERROS	0 - 65535	
5210	PARITY ERROS	0 - 65535	
5211	CRC ERROS	0 - 65535	
5212	BUSY ERROS	0 - 65535	
5213	SER FAULT MEM 1	0 - 3	
5214	SER FAULT MEM 2	0 - 3	
5215	SER FAULT MEM 3	0 - 3	

Note! Parameters 5206 - 5212 are displayed in hexadecimal format by the control panel. The panel displays three decimal points to indicate a hexadecimal number control panel.

0.A.1.4

Figure 3-1 An example of the control panel displaying a hexadecimal number A14 (2580 decimal).

Code	Description
5206	<p>BAD MESSAGES</p> <p>This diagnostics counter increases by one every time the ACS 160 finds any kind of communication error. During normal operation, this counter hardly ever increases.</p>
5207	<p>GOOD MESSAGES</p> <p>This diagnostics counter increases by one every time a valid Modbus message has been received by the ACS 160. During normal operation, this counter increases constantly.</p>
5208	<p>BUFFER OVERRUNS</p> <p>The longest possible message length for the ACS 160 is 32 bytes. If a message exceeding 32 bytes is received, this diagnostic counter increases by one every time a character is received and cannot be placed in the buffer.</p>
5209	<p>FRAME ERRORS</p> <p>This diagnostic counter increases by one every time when a character with a framing error is received from the bus.</p> <ul style="list-style-type: none"> • Communication speed settings of the devices connected to the bus differ. • Ambient noise levels may be too high.
5210	<p>PARITY ERRORS</p> <p>This diagnostic counter increases by one every time when a character with a parity error is received from the bus.</p> <ul style="list-style-type: none"> • Parity settings of the devices connected in the bus differ. • Ambient noise levels may be too high.
5211	<p>CRC ERRORS</p> <p>This diagnostic counter increases by one every time when a message with a CRC error is received.</p> <ul style="list-style-type: none"> • Ambient noise levels may be too high. • CRC calculation is not performed correctly.

Code	Description
5212	BUSY ERRORS In Modbus network, only one device can transmit at any given time. This diagnostic counter increases by one every time the ACS 160 receives a character from the bus while it is still processing the previous message.
5213	SER FAULT MEM 1 Last Modbus exception code sent. Refer to "Exception Codes" on page 4-3.
5214	SER FAULT MEM 2 Previous Modbus exception code sent.
5215	SER FAULT MEM 3 Oldest Modbus exception code sent.

Chapter 4 – Communication

This chapter describes the Modbus communication on ACS 160 drives.

Introduction to Modbus

Modbus is a serial, asynchronous protocol. The Modbus protocol does not specify the physical interface. Typical physical interfaces are RS232 and RS485, both of which are supported by the adapter.

Modbus is designed for integration with Modicon PLCs or other automation devices, and the services closely correspond to the PLC architecture. The ACS 160 drive 'looks like' a Modicon PLC on the network.

If detailed information regarding the Modicon Modbus protocol is required, contact your ABB supplier for a copy of Modbus Protocol Guide.

Register Read and Write

The ACS 160 has all drive parameter, control and status information mapped into a 4xxxx register area. This holding register area can be read from an external device, and an external device can modify the register values by writing to them.

There are no setup parameters for mapping the data to the 4xxxx register. The mapping is pre-defined and corresponds directly to the ACS 160 parameter grouping.

All parameters are available for both reading and writing. The parameter writes are verified for correct value, and for valid register addresses. Some parameters never allow writes (including Group 1 actual values), some parameters allow write only when the drive is stopped (including Group 99 setup variables), and some can be modified at any time (including e.g. Group 22 acceleration and deceleration ramp times).

Register Mapping

The drive parameters are mapped to the 4xxxx area so that:

- 40001 – 40099 are reserved for drive control registers
- 40101 – 40199 is reserved for the actual values (parameter group 1)
- 40201 – 40299 is reserved for parameter group 2
- 40301 – 40399 is reserved for fault and alarm information
- ... other parameter groups
- 49901 – 49999 is reserved for the start-up data

In this mapping, the thousands and hundreds correspond to the group number, while the tens and ones correspond to the parameter number within a group.

Register addresses 4GGPP are shown in Table 4-1. In this table GG is the group number, and PP is the parameter number within the group

Table 4-1 Parameter mapping.

4GGPP	GG	PP
40001 – 40006	00 Drive control registers	01 Command word 02 Reference 1 03 Reference 2 04 Status word 05 Actual value 1 06 Actual value 2
40102 – 40130	01 OPERATING DATA	02 SPEED ... 30 OLDEST FAULT
41001 – 41003	10 COMMAND INPUTS	01 EXT1 COMMANDS 02 EXT2 COMMANDS 03 DIRECTION
41101 – 41108	11 REFERENCE SELECT	01 KEYPAD REF SEL ... 08 CONST SPEED 7
...
49901 – 49908	99 START-UP DATA	02 APPLIC MACRO ... 08 MOTOR NOM SPEED

The register addresses between the groups are invalid. No reads or writes are allowed for these addresses. If there is an attempt to read or write outside the parameter addresses, the Modbus interface will return an exception code to the controller.

Exception Codes

The ACS 160 supports the standard Modbus exception codes. These are shown in Table 4-2.

Table 4-2 Exception codes.

Code	Name	Meaning
01	ILLEGAL FUNCTION	The function code received in the query is not an allowable action for the slave. ACS 160 : Unsupported Command.
02	ILLEGAL DATA ADDRESS	The data address received in the query is not an allowable address for the slave. ACS 160 : Address outside groups
03	ILLEGAL DATA VALUE	A value contained in the query data field is not an allowable value for the slave. ACS 160 : Value outside min-max limits ACS 160 : Parameter is read-only ACS 160 : Message is too long ACS 160 : Parameter write not allowed when start is active ACS 160 : Parameter write not allowed when factory macro is selected

Function Codes

The ACS 160 supports the Modbus function codes given in Table 4-3. If any other function codes are used ACS 160 returns an exception response with error code 01 (illegal function).

Table 4-3 Function codes.

Code	Description
03	Read holding registers
06	Preset single register
16 (10 Hex)	Preset multiple registers

The Control Word and the Status Word

Holding registers: 40001 (Control Word), 40004 (Status Word)

The Control Word (CW) is the principal means for controlling the drive from a fieldbus system. It is effective when the drive is in external (remote) control and the controlling commands are received through serial communication channel (set by parameters 1001 EXT1 COMMANDS, 1002 EXT2 COMMANDS and 1102 EXT1/EXT2 SEL).

The Control Word (detailed in Table 4-4) is sent by the fieldbus master station to the drive. The drive switches between its states according to the bit-coded instructions of the Control Word. See also state machine in Figure 4-1.

The Status Word (SW) is a word containing status information, sent by the drive to the master station. The composition of the Status Word is explained in Table 4-6.

Note! Operation of Control Word and Status Word conforms to ABB Drives Profile with the exception of Control Word bit #10 (REMOTE_CMD), which is not used by the ACS 160.

Table 4-4 The Control Word. See also the State machine in Figure 4-1.

Bit	Value	Description
0	1	Enter READY TO OPERATE
	0	Emergency OFF. Ramp to stop according to parameter 2203 DECELER TIME 1. Enter OFF1 ACTIVE ; proceed to READY TO SWITCH ON unless other interlocks (OFF2, OFF3) are active.
1	1	Continue operation (OFF2 inactive)
	0	Emergency OFF, coast to stop. Enter OFF2 ACTIVE ; proceed to SWITCH-ON INHIBITED .
2	1	Continue operation (OFF3 inactive)
	0	Emergency stop. Drive ramps to stop according to parameter 2205 DECELER TIME 2. Enter OFF3 ACTIVE ; proceed to SWITCH-ON INHIBITED .
3	0 - 1	Enter OPERATION ENABLED (Note that also the Run enable signal must be present on a digital input – see parameter 1601 RUN ENABLE.)
	0	Inhibit operation. Enter OPERATION INHIBITED
4		Unused.
5	1	Normal operation. Enter RAMP FUNCTION GENERATOR: ACCELERATOR ENABLED
	0	Halt ramping (Ramp Function Generator output held)
6	1	Normal operation. Enter OPERATING
	0	Force Ramp Function Generator input to zero.
7	0 - 1	Fault reset (enter SWITCH-ON INHIBITED)
	0	(Continue normal operation)
8 to 10		Unused
11	1	Select external control location 2 (EXT2)
	0	Select external control location 1 (EXT1)
12 to 15		Unused

Example on Using the Control Word

The following example shows how to use the Control Word to start the drive. When the power is connected for the first time, the state of the drive (see the state machine in Figure 4-1) is NOT READY TO SWITCH ON. Control Word is used to step through the state machine states until OPERATING state is reached, meaning that the drive is running and follows the given reference.

Table 4-5 Using the Control Word.

	Control Word Value	Description
Step 1	CW = 0000 0000 0000 0110 <div style="display: flex; justify-content: space-around; width: 100px;"> <div style="text-align: center;"> bit 15</div> <div style="text-align: center;"> bit 0</div> </div>	When this value is written, drive state changes to READY TO SWITCH ON.
Step 2		Wait at least 100 ms before proceeding.
Step 3	CW = 0000 0000 0000 0111	When this value is written, drive state changes to READY TO OPERATE.
Step 4	CW = 0000 0000 0000 1111	When this value is written, the drive starts, but will not accelerate. Drive state changes to OPERATION ENABLED.
Step 5	CW = 0000 0000 0010 1111	When this value is written, the ramp function generator (RFG) output is released. Drive state changes to RFG: ACCELERATOR ENABLED.
Step 6	CW = 0000 0000 0110 1111	When this value is written, the ramp function generator (RFG) input is released. Drive state changes to OPERATING. Drive will accelerate to the given reference and will follow the reference.

This example assumes that the ACS 160 is in remote control, that external control place 1 (EXT1) is the active control place (as selected by parameter 1102), and that EXT1 start and stop commands are received through serial communication (parameter 1001).

Table 4-6 The Status Word

Bit	Value	Description
0	1	ready to switch on
	0	not ready to switch on
1	1	ready to operate
	0	off1 active
2	1	operation enabled
	0	Not ready (OPERATION INHIBITED)
3	0 - 1	fault
	0	No fault
4	1	OFF2 inactive
	0	OFF2 ACTIVE
5	1	OFF3 inactive
	0	OFF3 ACTIVE
6	1	switch-on inhibited
	0	
7	1	Alarm is active. See Diagnostics section for a list of relevant alarms.
	0	No alarm
8	1	OPERATING. Actual value equals reference value (= is within tolerance limits).
	0	Actual value differs from reference value (= is outside tolerance limits)
9	1	Drive control location: REMOTE
	0	Drive control location: LOCAL
10	1	The value of first supervised parameter equals to or is greater than supervision limit. Refer to Group 32 Supervision.
	0	The value of first supervised parameter is below supervision limit
11	1	External control location 2 (EXT2) selected
	0	External control location 1 (EXT1) selected
12	1	Run Enable signal received
	0	No Run Enable signal received
13 to 15		Unused

References

References are 16-bit words comprising a sign bit and a 15-bit integer. A negative reference (indicating reversed direction of rotation) is formed by calculating the two's complement from the corresponding positive reference value.

Reference 1

Holding Register: 40002

Reference 1 can be used as the frequency reference REF1 for the ACS 160. The signal source of external reference 1 (REF1) must be set to COMM and external control location 1 (EXT1) must be activated. Refer to parameters 1103 EXT REF 1 SELECT and 1102 EXT1/EXT2 SEL.

Reference 2

Holding Register: 40003

Reference 2 can be used as the frequency reference REF2 for the ACS 160. The signal source of external reference 2 REF2 must be set to COMM and External control location 2 (EXT2) must be activated. Refer to parameters 1106 EXT REF 2 SELECT and 1102 EXT1/EXT2 SEL.

Fieldbus Reference Scaling

Fieldbus references are scaled as follows:

Reference 1: $20000 \pm \text{EXT REF1 MAX}$ (Hz, parameter 1105). Scaling Parameter 1104 EXT REF1 MIN is not used.

Reference 2: $10000 \pm \text{EXT REF2 MAX}$ (% , parameter 1108). Scaling Parameter 1107 EXT REF2 MIN is not used.

Fieldbus Reference

Fieldbus reference is selected by setting a reference selection parameter – 1103 EXT REF1 SELECT or 1106 EXT REF2 SELECT – to COMM, COMM+AI1 or COMM*AI1. The latter two enable correction of the fieldbus reference using analogue input AI1. The following table explains these selections. Note that the analogue input value is a percentage value (0-100 %) which can be seen in parameter 0118 AI1. When the analogue input is 50 %, the correction is 0. When the input is <50 % (>50 %), the correction reduces (respectively increases) the reference used.

Table 4-7 Correcting the fieldbus reference through analogue input.

Parameter Setting	Effect of AI1 Value on Fieldbus Reference
COMM	None
COMM+AI1	Corrected fieldbus reference = given fieldbus reference + analogue input AI1 value
COMM*AI1	Corrected fieldbus reference = given fieldbus reference * analogue input AI1 value / 50 %

Example of the effect of AI1 value on fieldbus reference.

Assume that 2008 MAXIMUM FREQ = 50 Hz

Assume that fieldbus reference 1 is 5000 (corresponding to 25 % of full scale) and voltage at AI1 is 3 V (corresponding to 30 % of full scale).

1. If setting $COMM+AI1$ is used, then corrected fieldbus reference is $25\% + 30\% - 50\% = 5\%$ or 2.5 Hz.

2. If setting $COMM*AI1$ is used, then corrected fieldbus reference is $25\% * 30\% / 50\% = 15\%$ or 7.5 Hz.

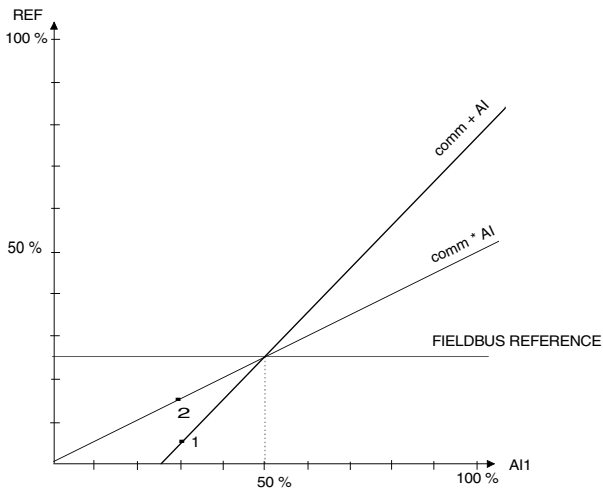

Actual Values

Actual values are read-only values containing information on the operation of the drive. Actual values are 16-bit words containing sign bit and a 15-bit integer. A negative value is given as two's complement of the corresponding positive value.

Actual Value 1

Holding Register: 40005

Actual output frequency. Scaling: 5000 $\hat{=}$ 50 Hz.

Actual Value 2

Holding Register: 40006

Actual output current. Scaling: 10 $\hat{=}$ 1 A.

Chapter 4 – Communication

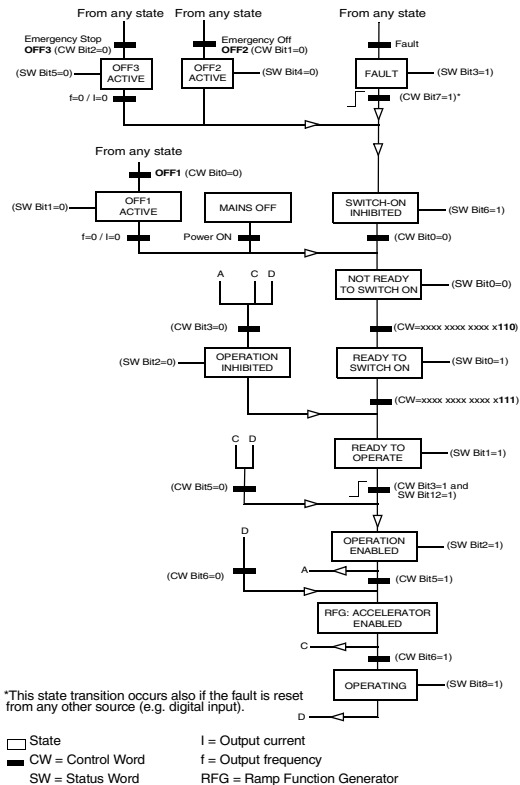

Figure 4-1 The state machine for evaluation of start and stop signals.

Fault and Alarm Status

The ACS 160 provides fault and alarm status words for the external control system. These data words are accessible only through the serial communication link but not from the control panel.

Fault and alarm status words are located in parameter group 3. The group also contains copies of the Control Word and Status Word. Group 3 parameters are of read-only type; however, both alarm words can be reset by writing a zero to them.

Table 4-8 Fault and alarm status words.

No	Name	Description
40301	MAIN COMMAND WORD	Read-only copy of the Command Word (40001). See page 4-4.
40302	MAIN STATUS WORD	Read-only copy of the Status Word (40004). See Table 4-6.
40305	FAULT WORD 1	Fault information. When a fault is active corresponding bit is set. Bit descriptions are given in Table 4-9.
40306	FAULT WORD 2	Fault information. When a fault is active, the corresponding bit is set. Bit descriptions are given in Table 4-9.
40308	ALARM WORD 1	Alarm information. When an alarm is active corresponding bit is set. Bits remain set until whole alarm word is reset by writing 0 to it. See Table 4-10.
40309	ALARM WORD 2	Alarm information. When an alarm is active corresponding bit is set. Bits remain set until whole alarm word is reset by writing 0 to it. See Table 4-10.

Table 4-9 Bit descriptions for fault words 1 and 2. See also the Diagnostics section in the ACS 160 User's Manual for more information about faults and fault codes.

Bit #	Fault Word 1	Fault Word 2
0	Overcurrent	Underload
1	DC overvoltage	Reserved
2	ACS160 overtemperature	DDCS Link
3	Fault current	Reserved
4	Output overload	
5	DC undervoltage	
6	Analogue input 1 fault	
7	Analogue input 2 fault	
8	Motor overtemperature	Hardware error
9	Panel loss	
10	Parameters inconsistent	
11	DC bus ripple too large	
12	Motor stall	
13	Serial communication loss	
14	External fault	
15	Output earth fault	

Table 4-10 Bit descriptions for alarm words 1 and 2. See also the Diagnostics section for more information about alarms and alarm codes. .

Bit #	Alarm Word 1	Alarm Word 2
0	Overcurrent controller alarm	Overload alarm
1	Overvoltage controller alarm	Autorest alarm
2	Undervoltage controller alarm	PID sleep alarm
3	Direction lock alarm	Autochange alarm. Reserved
4	Serial communication loss	Interlock alarm. Reserved
5	Modbus exception	Brake resistor overload alarm
6	Analogue input 1 loss	Reserved
7	Analogue input 2 loss	
8	Panel loss	
9	ACS 160 overtemperature	
10	Motor overtemperature	
11	Underload	

Chapter 5 – Fault Tracing

This chapter gives step-by-step diagnostics information for finding out the causes and corrections to the most common problems with the adapter.

Power LED of the adapter is illuminated, but Receive (RxD) and Transmit (TxD) LEDs are not blinking

- | |
|----------------------------------------------------------------------------------------------------------------------------------------------------------------------------------------------------------------------------------------------------------------------------------------------|
| <ul style="list-style-type: none">• The master device is not transmitting.• The cable is not correctly connected to connector X1/ X2 (in RS485 mode) or X4 (in RS232 mode).• Operation mode (RS485 or RS232) of the adapter is not correct: Check jumper S3. |
|----------------------------------------------------------------------------------------------------------------------------------------------------------------------------------------------------------------------------------------------------------------------------------------------|

Receive LED blinks but there is no response from the ACS 160 (Transmit LED is not blinking)

- | |
|----------------------------------------------------------------------------------------------------------------------------------------------------------------------------------------------------------------------------------------------------|
| <ul style="list-style-type: none">• The master device is not using the same communication settings as the ACS 160.• The ACS 160 is using the communication settings of the control panel: Turn power off and then on again. |
|----------------------------------------------------------------------------------------------------------------------------------------------------------------------------------------------------------------------------------------------------|

Receive and Transmit LEDs are blinking, but the drive does not follow commands given by the master device

- | |
|--------------------------------------------------------------------------------------------------------------------------------------------------------------------------------------------------------------------|
| <ul style="list-style-type: none">• The drive is not in remote control mode.• The drive parametering is incorrect: Control commands are not accepted from the serial communication channel. |
|--------------------------------------------------------------------------------------------------------------------------------------------------------------------------------------------------------------------|

Receive and Transmit LEDs are blinking, but the responses ACS 160 sends are not intelligible

- DIP switch S2 and parameter 5202 COMM SPEED do not have the same speed setting.
- Ambient noise level is too high.

The control panel is not operating and panel display blinks

- Panel is not properly connected to the drive.
- The drive is using different communication settings from the panel: Connect the panel and then turn power off and then on again.

Group 52 is not visible on the control panel

- Make full parameter set visible by selecting menu function -LG- and pressing and holding ENTER button down until display blinks.

Take advantage of the group 52 diagnostic counters. If necessary, use parameter 9902 APPLIC MACRO to restore the parameter settings of the ACS 160 to their default values and then reconfigure the drive.

Appendix A – Parameter Scaling

This chapter is intended for people who are using the drive data through the Modbus connection, and need to know in what units the data is available for reading and writing.

Effect of Resolution

Parameter values are read and written through serial communication using integer values. When the given parameter resolution is 0.1, desired value must be multiplied by 10 to produce the integer value.

For example, to set parameter 2202 ACCELER TIME 1 (resolution 0.1 s) to the value of 60.5 s, value 605 must be written through serial communication.

Signed Values

Normally, parameter values are represented as signed integers. Negative values are given in the 2's complement format. To calculate the 2's complement, take the corresponding positive value, negate it and add 1. Signed integer values range from -32768 to 32767.

Note! Diagnostic counter values (parameters 5206 - 5215) are represented as unsigned integers. In this case values extend from 0 to 65535.

The parameters and their resolutions are listed in the ACS 160 User's Manual.

Appendix A – Parameter Scaling

Appendix B– Technical Data

RS-485 Link

Compatible devices: All devices compatible with Modbus protocol

Size of the link: 247 stations including repeaters (31 stations and 1 repeater per segment)

Medium: Shielded, twisted pair RS-485 cable (Belden 9841 or equivalent)

Termination: Built in CFB-RS module

Maximum bus length: 1200 m

Topology: Multi-drop

Serial communication type: Asynchronous, half duplex

Transfer rate: 300 bit/s, 600 bit/s, 1200 bit/s, 2400 bit/s, 4800 bit/s, 9600 bit/s, 19200 bit/s.

Protocol: Modbus

CFB-RS

Enclosure: Cast aluminium

Dimensions: 124 x 79 x 42 mm (without cable glands)

Degree of protection: IP65

Mounting: Onto ACS 160 drive

Settings: Via drive interface (control panel)

Current consumption: 100 mA

Connectors: Two Phoenix Contact MC 1,5/5-ST-3,81 (5-pole, cross-section 1,5 mm² max) screw terminal blocks.

Appendix B– Technical Data

X1, X2		Description
1	-	No connection
2	C	Common
3	A	Data negative
4	B	Data positive
5	Shield	Cable shield

General: Complies with EMC standards EN50081-1 and EN50082-2

Appendix C– Ambient Conditions

Operation

The following conditions apply to stationary use of the module.

Installation Site Altitude: 0 to 2000 m above sea level. If the installation site is higher than 2000 m above sea level, please contact your local ABB representative for further information.

Temperature: -10 to +50 °C

Contamination Levels (IEC 721-3-3):

Chemical gases: Class 3C3

Solid particles: Class 3S3

Sinusoidal Vibration

(IEC 721-3-3, 2nd Edition 1994-12):

Max 3 mm (2 to 9 Hz)

Max 10 m/s² (9 to 200 Hz)

Shock (IEC 721-3-3, 2nd Edition 1994-12):

Max 250 m/s², 6 ms

Storage and Transportation

The following conditions apply to storage and transportation of the module in the protective package.

Temperature: -40 to +70 °C

Contamination Levels (IEC 721-3-3):

Storage:

Chemical gases: Class 1C2

Solid particles: Class 1S3

Transportation:

Chemical gases: Class 2C2

Solid particles: Class 2S2

Shock (IEC 721-3-3, 2nd Edition 1994-12):

Max 300 m/s², 18 ms

Appendix C— Ambient Conditions



ABB Industry Oy

P.O.Box 184

FIN-00381 Helsinki

FINLAND

Telephone: +358 10 222 000

Fax: +358 10 222 2681

3BFE 64390431 R0125

EN

EFFECTIVE: 23.3.2001