



ABB Ability™ Quality Management Solutions for pulp and paper

Outstanding process visibility and advanced control

At ABB, we're dedicated to results. Our focus is to help our customers strengthen competitiveness and profitability through continuous improvement.

From the pulping process through converting operations, our solutions provide superior value in maximizing quality, increasing performance and reducing operational costs.

Table of contents

04	Customer challenges
05–07	ABB Ability™ Quality Management Solutions
08–11	Network Platform scanners
12–17	Measurements
18–19	CD actuator systems
20–23	Quality and production process control
25–27	User interface
28–29	System integration
30–31	ABB Ability™ System 800xA: Commitment to a common architecture
32	Performance Services
33–35	Web imaging and monitoring
36	Lifecycle management
38	How we meet customers quality management needs

Customer challenges



Increased customer demands

Mills in mature, high-cost markets face tighter specifications and customer requirements, creating the need for higher levels of accuracy in quality testing.



Difficult conditions

Harsh, hot environments at mid-machine and press locations make measurements difficult.



High cost of rejects

Off-spec paper can lead to runnability issues, rejects and customer complaints, costing mills profit.



High input costs

Fiber, energy and labor costs can affect profitability and contribute to missed opportunities.



ABB Ability™ Quality Management Solutions

Leading-edge online measurement and control performance from the category creator

From our origin as the first on-machine paper property measurement system provider to the latest advanced control and analytics solutions of today, ABB solutions have earned a reputation for superior design and performance.

ABB is well-known throughout the industry as the supplier of choice for comprehensive, integrated quality measurement and control solutions for tissue, pulp, paper, packaging and specialty applications. From a singly applied Cross Direction (CD) actuator, to standalone measurement and web imaging systems through completely integrated, large scale paper mill solutions, our customers count on us as a reliable, performance-driven technology partner.

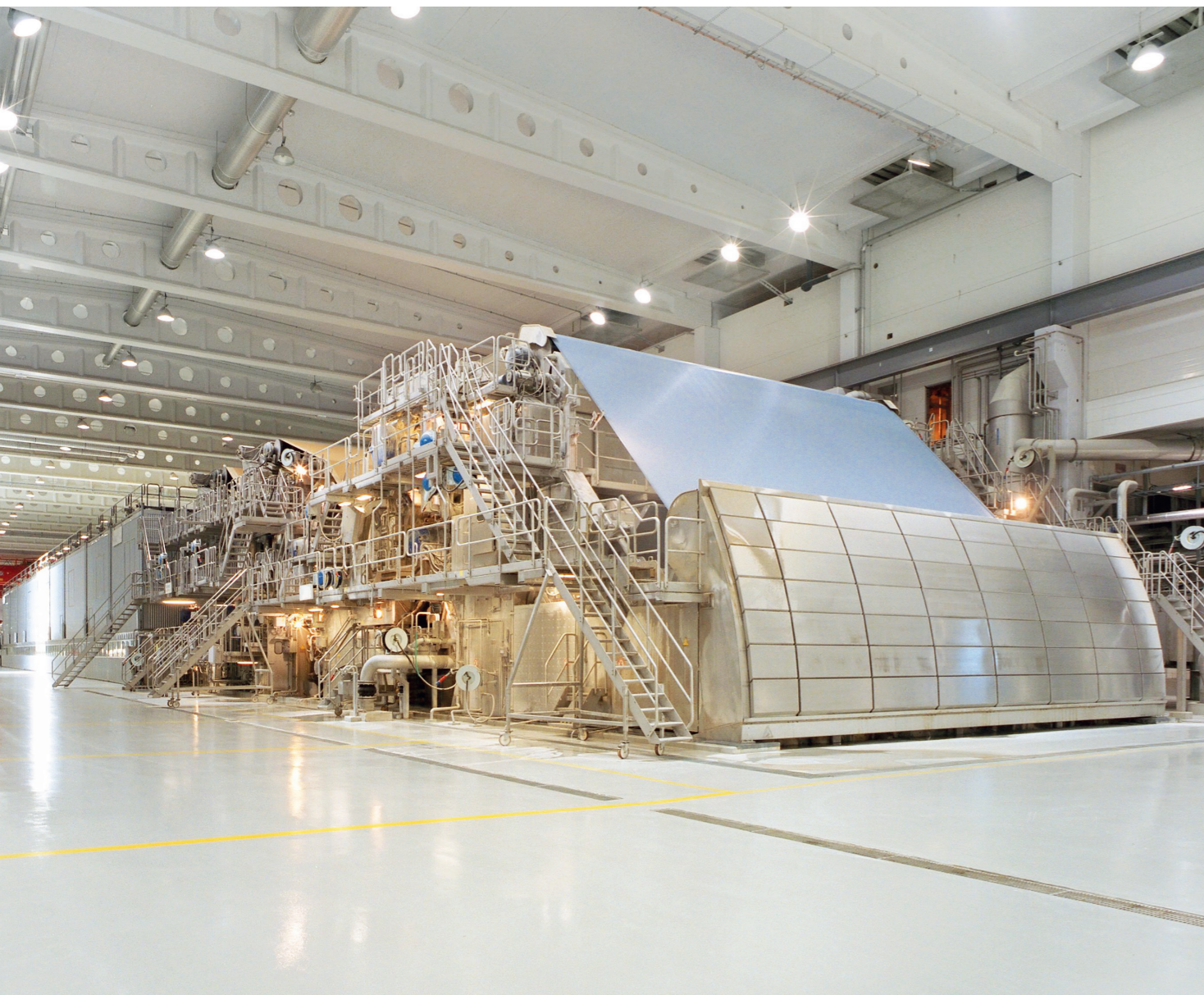
From inception, our company has valued and nurtured the contributions of a strong team of professionals to design, produce, apply and support our efforts in the pulp and paper industry. In fact, ABB has been providing paper makers with the most advanced measurements and controls available for over 70 years. With a growing team of almost 2,000 dedicated paper making experts, ABB has the resources to meet your challenges now and in the future.



ABB Ability™ Quality Management Solutions

An integrated system with a robust and reliable design, advanced analytics and an excellent user experience

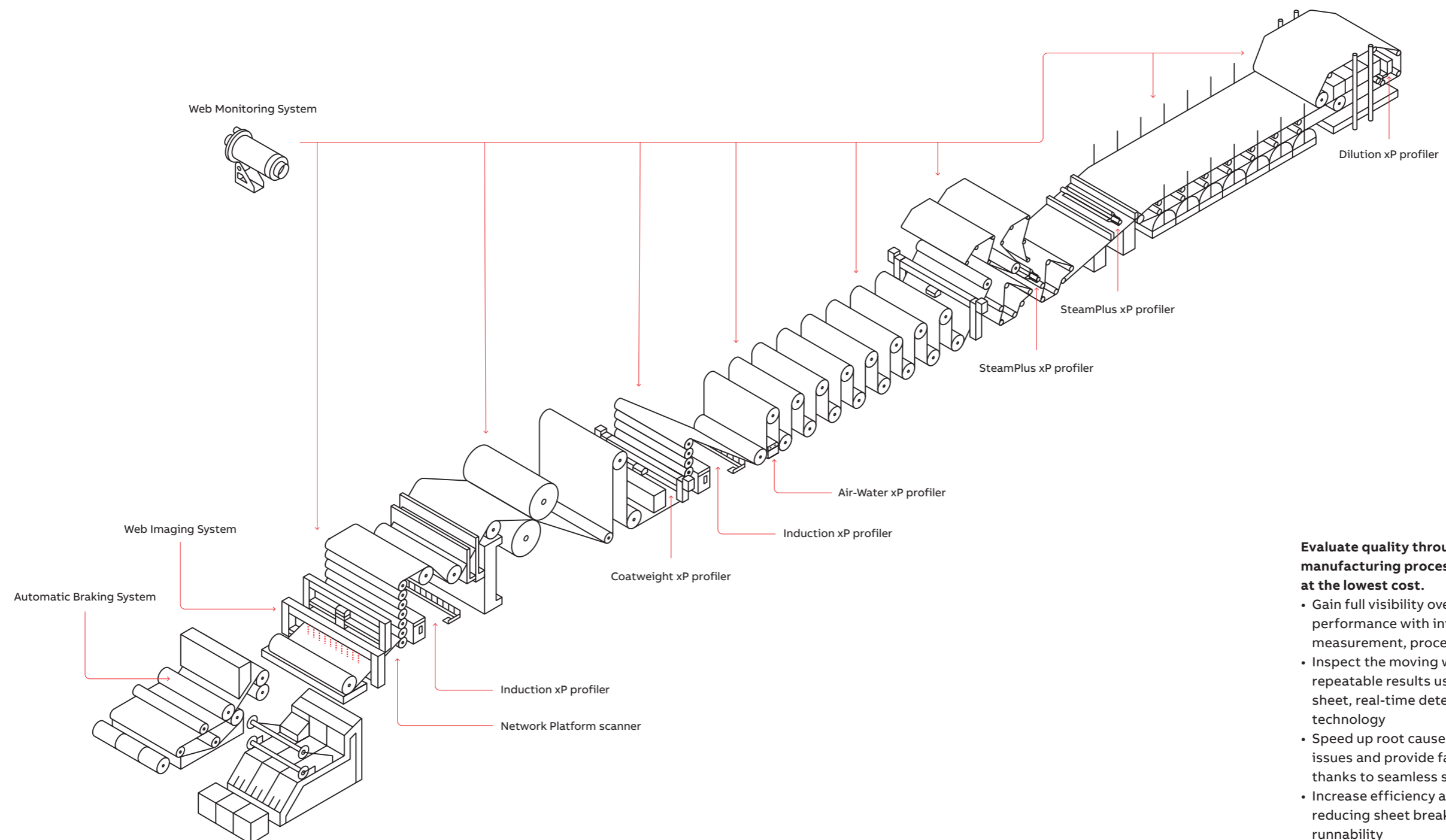

Evaluate quality throughout the entire manufacturing process to ensure on-spec paper at the lowest cost.

- Gain full visibility over process and system performance with integrated online measurement, process and quality controls
- Inspect the moving web with consistent and repeatable results using the most advanced full sheet, real-time detection and analysis technology
- Speed up root cause identification of quality issues and provide faster corrective action thanks to seamless system integration
- Increase efficiency and product output by reducing sheet breaks and optimizing runnability

Network Platform scanners

Necessary process information to optimize product quality

ABB provides scanning solutions on more paper machines than any other company. We have earned this trust by providing the most advanced Quality Control System (QCS) measurements, data acquisition and communication technology in the industry. This allows excellent insight into both the measurement system and paper machine health.

The industry-leading Network Platform family of scanners enables papermakers to apply the highest quality measurement technology on all applications. With a robust, sturdy design, advanced signal processing and sensor support features, mills gain precise measurements and maximum operational performance—even in the harshest of environments.



01 The industry-leading Network Platform family of scanners enables papermakers to apply the highest quality measurement technology on all applications.

Superior design and performance

ABB Network Platforms are the industry's strongest and most advanced scanners, providing the process information necessary to optimize product quality. All platforms are built to specified CD width for lowest installation cost and greatest flexibility.

The reinforced carbon steel "A"-beam construction with strong end columns provides superior vertical, horizontal and torsional rigidity. This stable structure is critical for precise alignment of sensor source and detector heads in harsh environments without the need for compensations.

Expect the same superior design and performance across all Network Platform scanners:

Design

- Smooth exterior with no external openings or exposed hardware or cables minimizes contamination
- Fully integrated system electronics are completely accessible from the end column
- Structural thermal stability means no liquid cooling and reduced utility costs
- "Seam-side down" upper and lower beams prevent materials falling in the structure
- Advanced external coatings resist chemical agents for long corrosion-free life
- Thermal coefficients between structure and the carriage rails allow for equal expansion and contraction
- Optical encoder ensures precise sensor positioning

Performance

- Accurate edge-to-edge measurement of all critical sheet characteristics
- Reduced risk of sheet breaks with wide sensor carriage that delivers a long-lasting, smooth ride across the moving web
- Most detailed product picture with full-sheet, 1,200-datapoint profiles
- Same-point and tight measurement of sheet edges with streak-optimized sensors
- Smallest variations revealed with edge-to-edge total sheet measurement and advanced edge modeling logic
- No realignment necessary throughout life of scanner with factory laser-aligned rails and stress-relieved platform structures

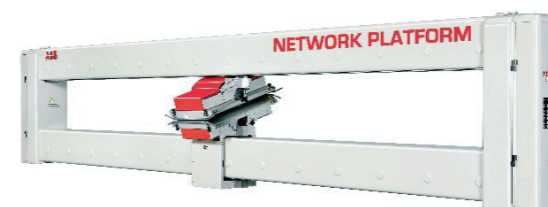

Network Platform scanner family

All Network Platforms include advanced capabilities such as extensive and remote diagnostics, step-by-step expansion and complete end column access for all maintenance tasks. These capabilities expedite installation while also minimizing downtime and startup requirements and lifecycle costs.

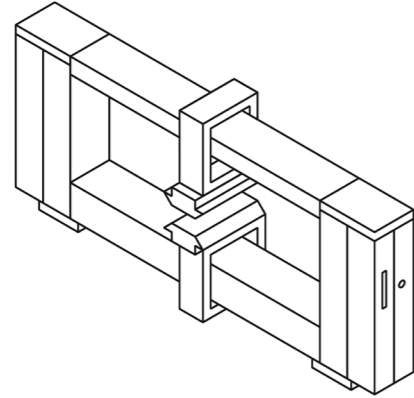

NP800

The Network Platform 800 (NP800) is a high-performance platform right-sized for scanning of small-to-mid size tissue and paper machines. The RedDot award-winning design provides customers with maximum uptime for continuous precision measurements that detect the slightest imperfections in the web. The advanced carbon steel “A” frame provides excellent strength-to-size ratio enabling cost-effective installation in the tightest locations and low operational costs.

- Maximum 6.23 M (245 in) sheet trim
- Up to 4 sensors at 25 degree passangle
- Construction: Monocoque 6 mm thick A-Beam with welded box end column

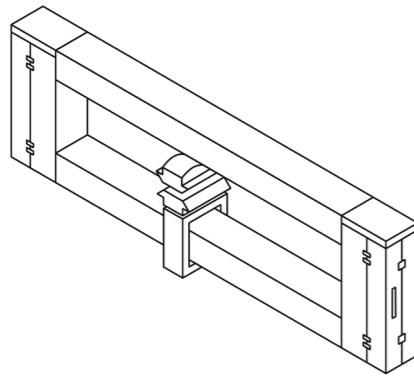

NP1200

The NP1200 provides scanning sensor support on processes of all sizes. Its solid 10 mm steel A-frame design is unparalleled in its ability to provide a rigid foundation for measurement success. This inherent stability for online sensors is true even when carrying multi-sensor packages at extreme pass lines across the widest sheets. To ensure reliable performance in even the harshest mill environments, the system is pressurized by air and has a welded and well-sealed exterior with no service covers along the beams.

- Maximum 10.23 M (403 in) sheet trim
- Up to 7 sensors at 25 degree passangle
- Extended widths and pass angles up to 45 degrees are available upon request
- Construction: Monocoque 10 mm thick A-Beam with welded box end columns

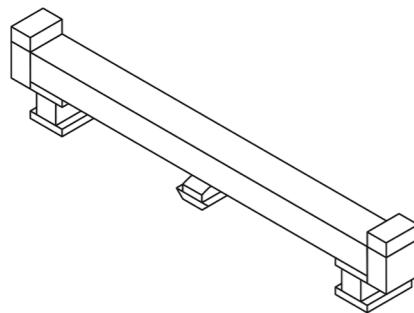

RNP1200

The RNP1200 supports ABB single-sided (reflective) measurements for process locations such as wet presses, coaters and size presses. Design is the same as the NP1200, but with a single beam so it is able to fit in tight machine locations where good reflective moisture or coat weight measurements are critical.

- Maximum 10.23 M (403 in) sheet trim
- Up to 2 sensors at 25 degree passangle
- Extended widths and pass angles up to 90 degrees are available upon request.
- Construction: Monocoque 10 mm thick A-Beam
- Mounting and head package customization is also available

—
02 Upgrade to the latest measurement technology without the need to replace an existing scanner.

Diagnostics

Included with all scanners are Network Platform Engineering Tools that allow users to commission, monitor, maintain and troubleshoot. These user-friendly applications—accessible via the mill network or through remote connection—include advanced health reporting, trending and sequence of event monitoring for the scanner, sensors and electronics.

Lifecycle path for scanners

Cost-effective lifecycle support and evolution is extremely important given the mission criticality of Quality Control Systems. Network Platforms can be easily updated with the latest processing and sensor technologies as they are developed to protect investments over the long term and ensure a solid foundation for ongoing operation and future QCS developments.

For previous generations, ABB follows a step-wise approach to scanner and sensor upgrades to minimize downtime, lifecycle cost and budget impact.

Smart Platform to Network Platform Upgrade

The Network Platform structure, mechanical drive system and cabling is functionally identical to Smart Platform designs.



—
02

As such, our cost-effective upgrade path leverages the existing scanning platform and adds new Network Platform software, signal processing and sensor support features, saving mills time and money.

With an upgraded frame, mills can also take advantage of new sensors specifically designed for the advanced computational and signal processing capabilities of upgraded architecture, such as moving from the old Hemi+ moisture sensor to the High-Performance Infrared Transmission (HPIR-T) moisture sensor, or upgrading from Smart Color to the new High Performance Color Measurement.

Benefits of an upgrade:

- Supports new online Spectral Analysis Package for sensor signals
- Enables upgrades to latest sensors most of which have higher sampling rates - some sensors up to 5,000 samples/sec
- Improved sensor/scanner diagnostics package and configuration tools
- Enhanced alarm and event handling for diagnostics
- Significantly improved software update, backup and restore functionality

Measurements

Improve paper quality with precise and continuous online measurement

With over 70 years of experience specifically in online paper property measurement, ABB is an industry leader in providing unique, leading-edge measurements to optimize machine stability and improve process efficiency.

ABB's robust and reliable sensors provide high resolution, precise and accurate measurements that take advantage of a unique compact design for continuous online measurement even in the harshest environments. Advanced diagnostics and reporting facilitate faster troubleshooting and reduced maintenance cost and downtime. Remote support is also available.

We offer complete measurement solutions including multiple options for basis weight, moisture, caliper and coat weight. This allows the choice for application specific, process-optimized solutions.



Weight

ABB's heritage includes the development of nucleonic basis weight measurement for the paper industry. Since that time, our industry-leading approach has expanded to include new technologies for many applications.

• Nucleonic Basis Weight



ABB Basis Weight Measurement provides unparalleled accuracy and streak resolution for optimum MD and CD weight control all in a compact design. The sensors use Krypton (STLK11) or Strontium (TLS1) isotopic sources, depending on the application requirements. Each application-optimized sensor uses radiation transmission techniques to achieve laboratory quality accuracy and precision on a wide range of paper grades. Factory calibration ensures single, linear measurement range for long-term accuracy.

• High-Performance Infrared Fiber Weight (HPIR-FW)

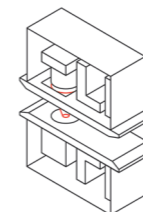
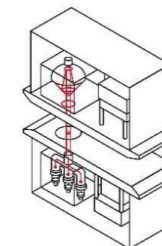

For tissue and non-woven measurement applications, ABB provides a proven design that delivers safe and reliable performance to directly measure fiber weight, moisture and temperature in a single sensor without radiological isotopes and the regulations associated with them.

With these highly precise measurements, operators can more confidently use MD and CD controls for reduced variability, faster start-ups and grade changes while also shifting targets closer to acceptable quality limits to save on energy and raw material costs.

Virtual measurements

In addition to our full lineup of physical sensors, ABB offers Virtual Measurements that use machine and process inputs to produce online calculations of important process variables or product properties. These measurements can be used to provide:



Online measurements that are not available from physical sensors (e.g. strength)



Stand-in virtual measurements for physical sensors when physical sensors are unavailable



More frequent measurements based on infrequent physical measurement and process variables



Validation measurements for direct measurements from physical sensors

Virtual Measurements utilize models generated from machine learning technologies to predict an online measurement, increasing the frequency of the measured paper, pulp or process property. These inferred measurements are available in informative, user-friendly displays that also include alarms, alerts and performance indicators. With confidence in the reliability and accuracy, maintenance and operations can take action to reduce variability and achieve quality, productivity and profitability targets.

Moisture

Almost every controllable variable on the paper machine has an impact on moisture. ABB uses the latest technologies in order to provide superior online moisture measurements for CD and MD control.

• High-Performance Infrared Transmission (HPIR-T)

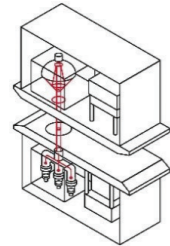

ABB's HPIR-T is the premier moisture and sheet temperature sensor with an accuracy that helps maximize control performance to save both energy and fiber costs. HPIR-T sets a new standard for precision by increasing speed and number of measurements; its innovative optical design doubles the signal-to-noise ratio of the instrument to provide an industry-leading moisture measurement rate of 5000 per second. Robust and inherently stable, it is a consistently high performer even in severe environments. HPIR-T is air-cooled, field replaceable, and without continuously moving parts.

• Microwave

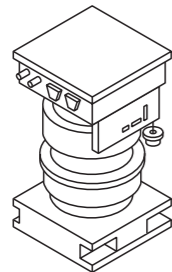

Microwave Moisture Sensors have been specifically designed for the most challenging paper web applications; where basis weight and water weights are high or over a broad range of temperatures. The unique properties of microwaves ensure that the moisture measurement is unaffected by ink residues, pH, inorganic fillers or colored pigments, which makes it particularly suitable for applications with significant recycled content. Measurement output is robust, stable and insensitive to external influences.

• High-Performance Infrared Reflection (HPIR-R)

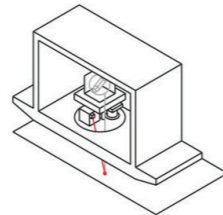

Mid-machine and wet press moisture measurements help optimize energy, press loading and quality performance while also detecting streaks prior to the size press. The Reflection Moisture sensor provides papermakers with both process insight and installation flexibility. The single-sided, non-contacting moisture measurement can be applied across a wide moisture and location range; it is usually mounted on an RNP1200, allowing the sensor to be deployed in tight and/or hot locations or fabric-backed processes.

Color

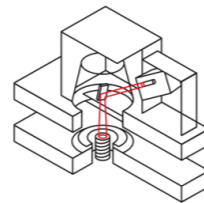

High-Performance Color Measurement provides color, brightness, opacity and whiteness measurements while scanning over the moving web. The next-generation sensor incorporates novel LED technology to make color measurement faster and more reliable by using a high-speed spectrophotometer. The sensor works in conjunction with ABB's advanced Color Control to minimize off-spec product and reduce shade change and start-up times, while helping mills precisely control color to a target shade.

Caliper

ABB Caliper sensors measure product thickness and deliver unparalleled accuracy, fast response time and streak resolution for optimum CD caliper control and process analysis.

• Glide Technology (GT) Caliper

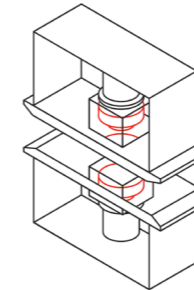

With patented gliding technology and a low density, aerodynamic design, GT Caliper glides smoothly over the sheet to deliver superior measurement without marking or damaging the sheet. Caliper options include a light touch solution for the most delicate processes and sensing heads optimized to reduce dirt pickup on grades with high recycle content.

• Optical Caliper

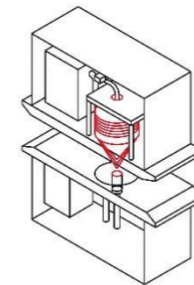

Dual-sided contacting caliper sensors pose challenges for certain applications. ABB has developed a new Optical Caliper sensor that is non-laser based, eliminating measurement errors caused by light penetration into the sheet. Instead, the revolutionary technology is based on the confocal displacement method that delivers unrivaled accuracy and stability.

Fiber Orientation

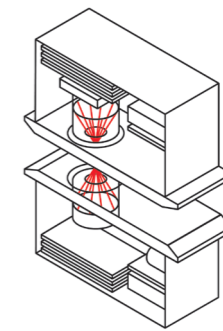

The greatest insight into runnability can be gained when comparing the difference in fiber orientation between two sides of the sheet. ABB's laser-based Fiber Orientation sensor delivers continuous online, two-sided measurement providing information on both fiber angle and ratio. This helps eliminate process problems and optimize sheet strength and mechanical conditions faster than relying on lab measurements alone.

Ash



ABB 2-Component and 3-Component X-Ray Measurements accurately measure ash weight on a broad range of applications. These sensors are highly sensitive to inorganic additives used in the production of quality paper, such as fillers and coatings. Pre-calibrated at the factory, these sensors accurately measure the ash weight of up to three components simultaneously.

Gloss

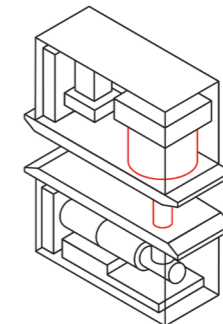
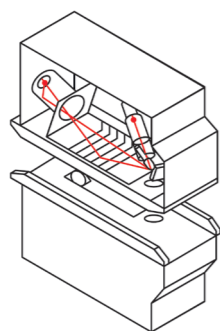

Leveraging a measurement principle that simulates the human eye's perception of gloss, Gloss Measurement provides continuous online measurement in accordance with TAPPI standards and offers flexibility to meet differing machine requirements. The compact, totally enclosed measurement design includes high intensity LED, which ensures low maintenance and long-term reliability.

Optical Properties (Optipak)

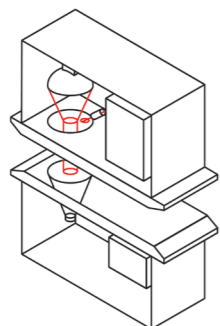

The Optical Properties Measurement combines measurement of three visual paper properties in one compact package: Formation, Opacity and Brightness. Continuous and repeatable measurement of sheet formation online allows papermakers to capitalize on this dimension of process visibility while also measuring opacity and brightness according to TAPPI standards for substantial economic and quality benefits.

Coat Weight

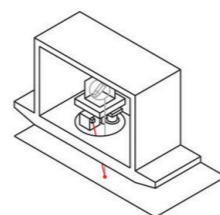

Customer requirements and process conditions require a consultative approach to coat weight technology selection. ABB offers the expertise and technology to meet your requirements by offering multiple options.

• **Direct Infrared (IR) Coat Weight**

ABB's IR Coat Weight provides direct measurement of coating components and percent moisture at each web surface through its unique focusing device, detection capabilities and signal processing of many infrared wavelengths. This integrated solution for measurement, process control and supervision provides great flexibility and performance; it is designed to overcome challenges posed by applications such as heavy grades, simultaneous coating of both sides of the sheet and limited machine space. Plus, our AutoCal method processes signals from multiple online sensors for unprecedented, optimized measurement.

• **Dry Weight Difference**

ABB's high signal-to-noise ratio Basis Weight measurement is combined with our highly accurate moisture measurements to offer unparalleled coat weight accuracy.

• **X-Ray (Ash) Weight Difference**

For lighter grades of paper needing the highest accuracy and precision, X-ray Difference offers high measurement sensitivity to coating solids, combined with low sensitivity to cellulose and water. ABB's patented X-ray filtering techniques eliminate calibration shifts due to coating composition changes.

Choosing the right sensors for your mill

Measurement	Best for	Benefits
Weight		
Nucleonic Basis Weight - STLK-11	High resolution weight measurement for paper and board grades <1080 gsm	Excellent process visibility and accuracy
Nucleonic Basis Weight - TLS-1	Board and pulp grades >1080 gsm up to 4900 gsm - Harsh environments	Excellent reliability and broad range
HPIR-FW	Light tissue and towel grades with virgin fiber	Single sensor for multiple properties. Lower cost and greater simplicity; no nuclear source
Moisture		
HPIR-T	All paper and board grades < 500 gsm	High accuracy Ultra-fast measurement
Microwave	Heavy pulp and board grades, grades with very high optical broadband light absorbers	Excellent measurement accuracy in harsh environments
Reflection	All grades that require a single sided moisture measurement; particularly good for heavy grades in hot, mid-machine locations	Excellent precision and accuracy. Can be installed in tight locations
Caliper		
Glide Technology (GT)	All grades up to 2032 microns (80 mils) that can use dual contacting measurement	Excellent precision and accuracy; reduced maintenance; good performance with contaminants; lower cost
Glide Technology - Light Touch (LTGT)	Grades up to 2032 microns (80 mils) with surfaces sensitive to marking	Excellent precision and accuracy; reduced maintenance good performance with contaminants
Optical	High end grades up to 1016 microns (40 mils)	Excellent process visibility and CD performance with minimal process intrusions
Coat weight		
Dry Weight Difference	All coated grades	Excellent precision and accuracy
X-Ray Difference	Lighter coated grades and those with need for excellent precision and accuracy.	Best resolution and precision on light coated grades
Direct IR (reflection)	Coated board applications with tight inter-coater space	Excellent precision, good accuracy with Autocal



CD actuator systems

Accuracy, precision and speed

Fast, precise response to dynamic production and quality challenges in the cross direction with advanced control, analytics and diagnostics from ABB's CD actuator systems.

Weight xP

ABB's Weight xP suite is designed for better basis weight or coat weight control and features advanced electronics and a rugged design that is both robust and highly reliable. The common system architecture enables easy installation and maintenance.

By combining absolute position measurement with ABB's patented fusion sensor technology, these actuators deliver unsurpassed precision, speed and diagnostics.

Benefits of choosing the Weight xP family of actuators:

- Improved machine performance and runnability
- Increased efficiency with faster grade changes
- Decreased raw material usage
- Reduced rejects and improved quality

Slice xP



ABB pioneered stepper control of headbox slice spindles in 1985, with close to a thousand headboxes with ABB actuators in operation. With Slice xP, weight profile variability is minimized by the precise positioning of the slice lip for optimum stock flow adjustments.

Dilution xP

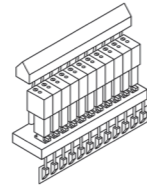
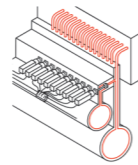

ABB's Dilution xP actuators have been installed on consistency profiling headboxes from all leading suppliers and can be fitted to any type of dilution valve. Weight profile variability is minimized by accurately adjusting the valve opening to control the flow of dilution water. optimum stock flow adjustments.

Whatever your needs, ABB's actuators offer the speed and accuracy needed for superior control

Suitable for	Weight xP			SteamPlus xP	Air-Water xP	Induction xP Plus
	Slice xP	Dilution xP	Coatweight xP			
CD weight	•	•				
CD moisture	•	•		•	•	
CD caliper	•	•				•
CD fiber orientation	•					
CD coat weight			•			
CD gloss						•
Uncoated papers	•	•		•	•	•
Coated grades	•	•	•	•	•	•
Uncoated packaging	•	•		•	•	•
Tissue	•	•		•		

Coatweight xP

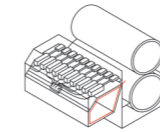

ABB's Coatweight xP delivers fast, accurate and reliable coating profile bar positioning. The actuator ensures an optimum, smooth coating application through precise positioning of the coater blade.

SteamPlus xP



ABB SteamPlus xP precisely and efficiently applies steam close to the sheet surface to minimize profile variability and reduce dryer section steam usage. Unique to ABB's diffuser design is its ability to keep the steam jets more than 100mm from the sheet to protect against pulp build up and blockages. That, coupled with its maintenance-free T880C actuator design, proprietary screen slides and integrated cleaning system means mills benefit from steady steambox performance without the need for regular maintenance, improving fiber usage and paper quality.

Benefits

- Reduces moisture profile variability by up to 80%
- Manage steam usage for 5-10%+ increase in production and/or 5-10% reduction in energy costs
- Improved reel build, sheet break recovery and runnability
- Increased press felt life, sheet strength properties and sheet surface properties

Air-Water xP

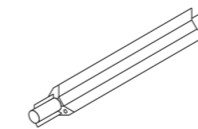
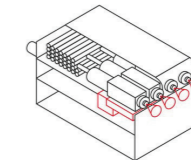

The Air-Water xP is a re-moisturizing system that delivers excellent sheet absorption due to its patented atomizer design. By producing predictable, homogeneous droplets, the actuator maintains precise flow, impervious to wear or water pressure variations while being resistant to plugging.

Benefits

- Up to 80% reduction in profile variability
- Improved reel building and runnability
- Fast recovery at start-up and after grade changes or process upsets

Induction xP Plus

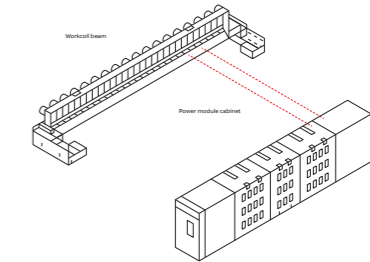

Mills will reduce caliper variability with ABB Induction xP Plus. The system heats the calender roll by electromagnetic induction, and the resulting increase in temperature enables rapid corrections to sheet finishing profiles.

Benefits

- Ensures maximum heating in concentrated area in the shortest time
- Reduces CD caliper variability by up to 90%
- Delivers up to 80% improvement in recovery after sheet breaks and start-up
- Enables best sheet finishing for gloss, smoothness and printability

Quality and production process control

Maximizing and replicating quality

As the linchpin of the QCS, quality and process controls are highly reliant on all the components working together.

ABB's measurement and control packages operate seamlessly together to improve quality for pulp, paper, packaging and tissue makers by reducing variability, improving grade repeatability and on-grade utilization.

Mills also benefit from optimized production with minimized energy consumption, increased throughput and improved availability of both resources and the machine.

With proven availability, built-in performance KPIs and local support connected to a global network of extensive papermaking expertise—all of which can only be found with ABB—mills can achieve sustained performance.

- Weight
- Moisture
- Ash
- Opacity
- Coat weight
- Caliper

Machine Direction Controls

ABB's Machine Direction (MD) Controls ensure minimum variability in paper properties while minimizing fiber and energy consumption using a model-based control approach. MD Controls not only allow for the best steady-state disturbance rejection during cruise operation, but they also significantly reduce off-spec time during start-up and sheet break recovery through fast tracking response.

Features

- Proven robust model-based approach with intuitive tuning
- Model error filtering maintains true measurement signal while optimizing disturbance rejection and actuator energy consumption
- Integrated operator interfaces

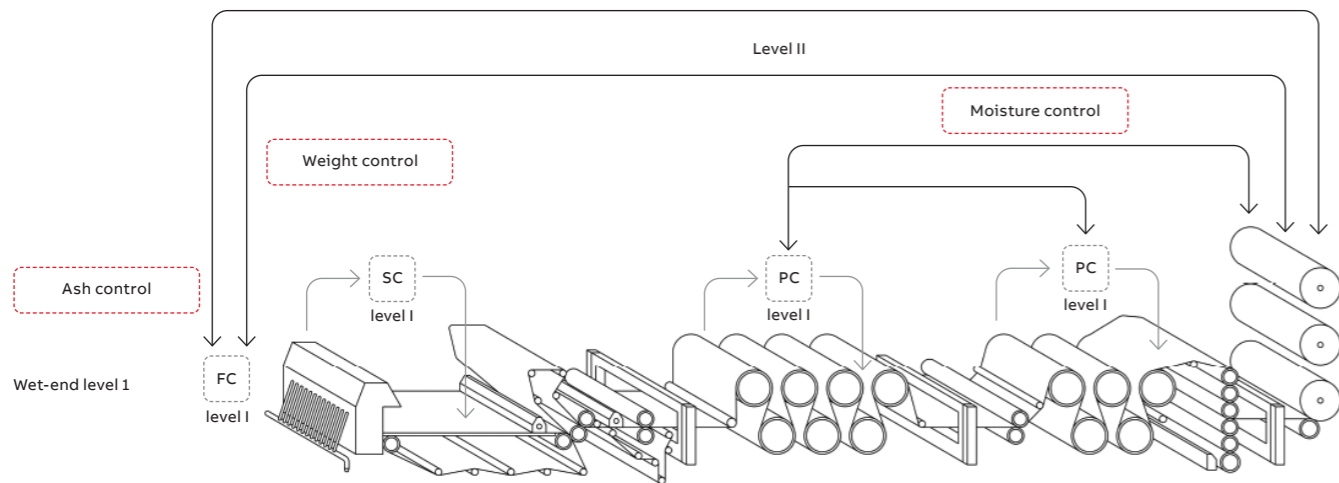

- Yankee-Hood
- Crepe ratio

Machine Direction – Tissue Controls

ABB's MD Tissue Controls reduce energy consumption and improve the utilization of equipment in the most efficient way. Yankee hood control enables the tissue maker to make use of the faster dynamic response in hood temperature, while maintaining steady state with the less expensive Yankee steam pressure. This maximizes energy efficiency while reducing moisture variability and start-up/grade change response.

The crepe-ratio control helps maintain the required speed difference between Yankee and reel, optimizing creping performance.

Features

- Hood temperature ratios
- Flexible moisture actuator and mode handling
- Selectable crepe-ratio entry format

- Single Color
- Dual Color
- UV Brightness
- Advanced Shade Change

Machine Direction Multivariable Color Control

Papermakers can exceed emerging requirements on sheet color and shade uniformity with ABB's proven Machine Direction Multivariable Color Control. Designed to provide optimal control utilization under changing conditions, Multivariable Color Control helps mills minimize rejects and optimize dye usage.

Not only does this minimize the difference between the actual and target shade, but it also gives confidence to operators to maintain a control-on state.

Features

- Full spectrum top, bottom or dual-side color and brightness control
- Brightness control of actuators using fluorescence or optical brightening agents
- Flexible color kitchen configurations and control
- Master-slave dye configuration available
- Support for mixed dye pump types
- Shade setup, handling and changes can be independent of or combined with grade changes

Advanced Shade Control brings the shade to a new target in conjunction with or independent of grade changes. This considers both the spectral aspects of color and dye, as well as time-domain responses, minimizing off-spec time.

ABB's highly-intuitive, color system matrix automatically calculates the online control for multiple actuators for desired dye additions.

03 & 04
The second graph shows on average how much faster shade changes take using Advanced Shade Change (ASC) control.

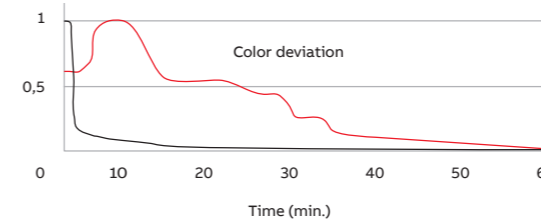

- Without automatic shade change —
- With automatic shade change —

Statistical distribution of shade change time

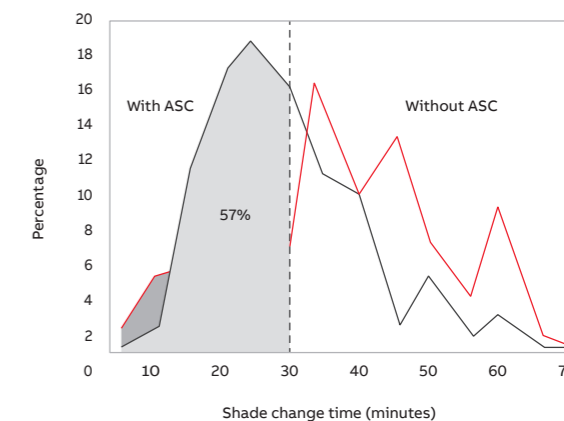

- Weight
- Moisture
- Caliper
- Fiber orientation
- Coat weight
- Finishing
- Local Variability Control (automatic mapping)

Multivariable Cross Direction Control

For even the most challenging cross-directional processes, ABB's Multivariable Cross Direction (MCD) Control optimizes and balances multiple paper quality CD profiles, while coordinating the contributions of multiple sets of CD actuators within their optimal operational limits.

ABB's MCD Control not only allows for the best steady-state or cruise performance, but it also significantly reduces start-up and sheet break recovery time while minimizing fiber and energy consumption. MCD Control can also be implemented as a standalone or hybrid companion. It can be configured for third-party profiles or actuators when required and includes a vast number of third-party actuator interfaces to minimize implementation time.

ABB's MCD Control is intuitive and simplifies both the operation and maintenance experience, resulting in less erroneous operator interactions and troubleshooting time to maintain control performance.

Features

- True multivariable high-resolution CD-control and process modeling
- Integrated operator interfaces
- Advanced spatial modeling and filtering techniques combined with temporal dynamic response modeling
- Integrated bump test and modeling application
- Local variability control (LVC) dynamic mapping automates and prevents performance deterioration

05 Paper machine example, highlighting the need for a multivariable approach due to coordination of multiple actuators influencing weight, moisture, caliper and fiber orientation

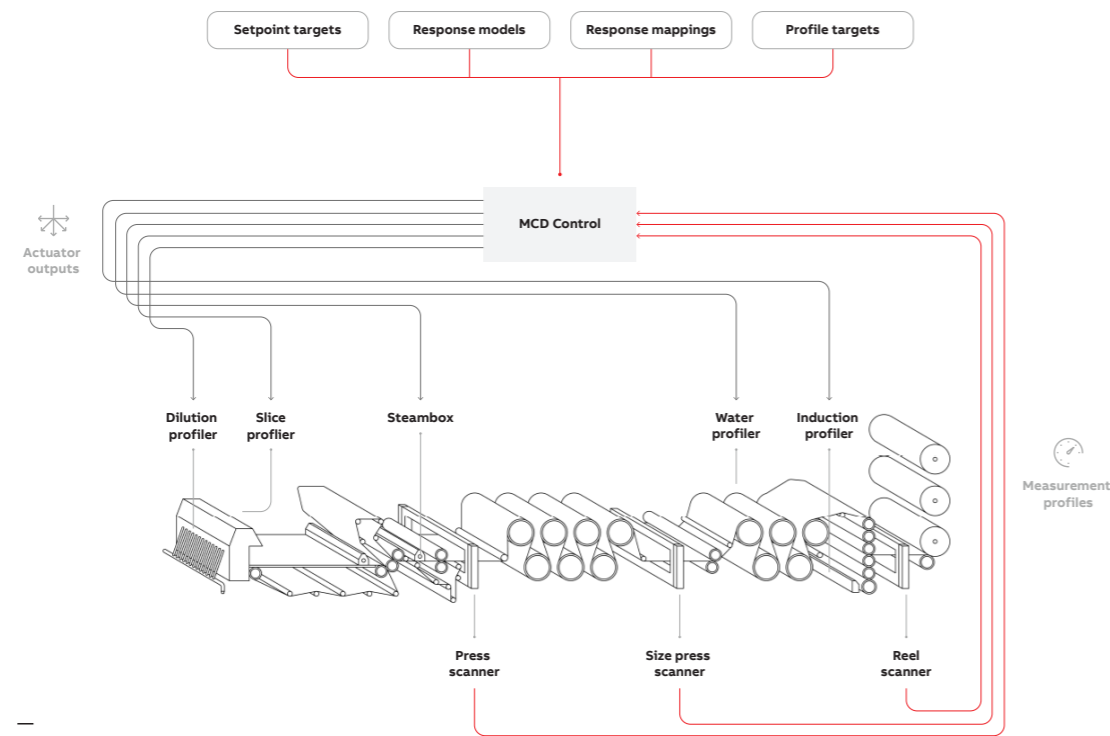

05

- Headbox
- Speed optimization
- Stock and ply loading
- Consistency compensation
- Crepe ratio control
- Bulk compensation
- Yankee/hood control

Optimizing Controls

Finding the operational sweet spot is challenging when attempted manually. Optimizing controls identify performance gaps and consistently push machine performance to an ideal state taking quality, production and process constraint parameters into consideration.

Examples include:

- Speed Optimization Control identifies slack in steam, stock flow and/or machine speed to help maximize production rates within established quality and process constraints

- Ply Loading takes the individual ply dynamics into account, allowing the operator to configure each ply as the grade specification or current operational conditions require, and ultimately shaping a unified weight control for optimized ply distribution
- Consistency Compensation provides flexibility in determining the actual consistency measurement to be used (instrument reading, calculated bias, or lab value) by the Ply Loading and Dry Stock Flow Control features, minimizing process upsets before consistency changes reach the machine

- Automatic Grade Change
- Coordinated Speed Control

06 Graphs showing automatic grade change performance.

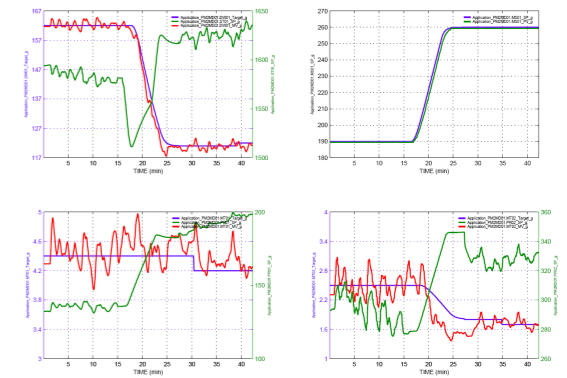

06

07 Performance for Wet End Control is made visible and sustained with built in, default, and configurable key performance indices and dashboard interfaces.



07

- Ash Control
- White water consistency
- Broke flow filler disturbances

Wet End Controls

The traditional approach of using retention aids to control white water consistency is far from optimal with the ever-changing retention properties of the base sheet and disturbances to the fiber flow's base filler content. This can lead to runnability issues in dewatering, excessive variability in ash content and myriad inefficiencies, particularly for filler and ash-heavy applications.

ABB Wet End Control takes full control of the short circulation loop to reduce variability and runnability issues, while decreasing fiber, energy and chemical usage.

By combining robust and predictive model-based control techniques to dynamically adjust to process changes—while simultaneously finding ways to optimize operational costs within process constraints—Wet End Control helps mills maximize productivity and profit.

User interface

Flexible displays for local-to-mill-wide visibility

— 08 Contour map showing dry weight mapping issues

— 09 MCD- overview, selected zone mapping response highlighted

The QCS user interface provides a comprehensive set of role-based displays and analytical tools tailored for both local and remote users as well as different levels of the organization.

Based on and integrated with the ABB Ability™ System 800xA platform, mills benefit from a standard but modification-ready QCS display in a secure, feature-rich environment that meets a wide range of user requirements.

Operator Interface

The operator interface is purpose-built to give the operations team an overview of the process in an easy-to-access and digest layout for swift, intuitive decision making. Local languages are fully supported.

It is preconfigured in a best practice layout that is based on ABB's extensive system and process expertise from decades of serving mills worldwide. An important advantage of this configuration is the reduction of complexity for each display to enable faster operation and decision making while facilitating easier onboarding and training of new team members.

Information is segmented into process sections to avoid overwhelming the operator. Navigation between sections can be customized by user preference. Users can instantly view and operate high-resolution measurements, MD and CD variations, profile contour maps, reel reports, grade reports, documentation and support tools.

More complex information can be made available to the user to better understand how specific variables interact, such as how CD actuators or a PID-controller response will behave. Some sections include a prediction horizon, enabling the operator to have awareness of the full projected response.

Specifically, the Multivariable Cross Direction (MCD) overview display includes the controlled error profile as well as the participating actuator sets in a profile, zone-based style (figure 09). The back-end mapping feature associates each zone response onto the error profile, eliminating time spent on understanding the actuator profile response relationship.

All trend data is easy to export to standard spreadsheets for analysis. Access to real-time quality control information enables better process decisions, reducing waste, saving raw materials and ultimately increasing profitability and shareholder value.

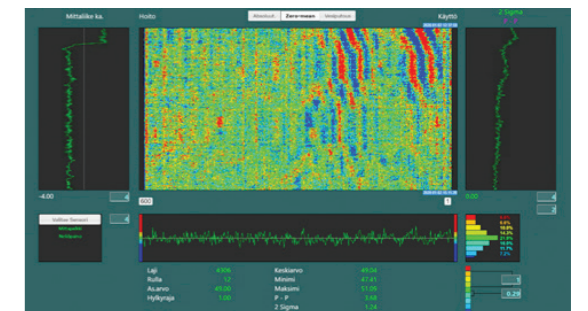

— 08



— 09

- 10 MCD bump test
- 11 Color overview display with plot
- 12 Multivariable CD Control overview display

Engineering Interface

The engineering user-interface is focused on enabling the maintenance and engineering teams to provide an efficient environment to continuously sustain performance. This includes asset optimization, controls performance, and modeling and mapping for swift on-site or remote troubleshooting.

Controls performance

Efficiently sustaining the performance of controls is the most important task for all engineering operations—especially the modeling and tuning of process controls. For example, performance indices provide the engineering user with awareness of control performance.

Modeling and mapping

The MCD controls include a suite of maintenance related displays to easily maintain modeling and mapping without the need for any offline tools. The integral bump-test scheduler and execution module as well as an easily accessed bump test analysis module increases speed of analysis (figure 10). This simplifies the representation of the active spatial response model and identified process mapping.

Grade and shade code handling

Online or offline grade code handling easily manages both grade codes and grade grouping. It allows engineering personnel collaboration with paper making subject matter experts using a simple import/export functionality. Grade and shade file maintenance is independently managed so that similar shade targets can be maintained across the grade structure.

Simulation

An included process simulation package allows for activities such as system validation and operator training to be accomplished without the need for a complete system installation and startup. Training and analysis can be done early and in a safe environment.

Graphics building

Graphics building is accomplished in a very straightforward way with a complete set of tools and a palette of pre-configured elements. This simplifies display building, supports the needs of power users and allows operator display maintenance closer to final users. The back-end xml-based graphics source code is available, making for simplified upgrades.



10

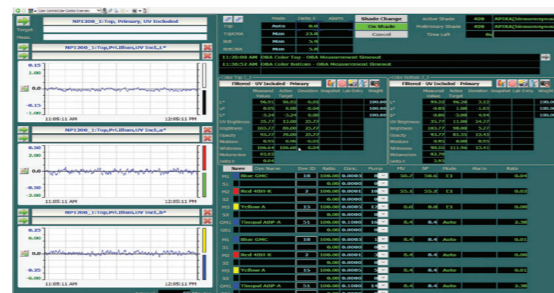

11



12

13 Online Spectral Analysis display

14 Color measurement overview display

15 Automatic grade change display

Diagnostics displays and OSA

Diagnostic displays allow operators, maintenance and engineering personnel to have access to diagnostics information both for the QCS system and the paper machine process. The system status and a full featured, filterable, sectionable and shelveable process alarming package is included with the system.

Scanners and sensors all have associated health pages and performance reports, assisting shift-based maintenance to be the first line of response for urgent troubleshooting as well as preventive and corrective maintenance. All diagnostics displays and information can be remotely accessed with security considerations tailored to the individual user or company protocol.

Online Spectral Analysis (OSA) is a software tool for process engineers and skilled operators to view and detect the spectral contents of sheet quality variations while a paper machine is running. It empowers machine operators and process engineers to detect their product and process problems in real-time and associate sheet quality issues with machine problems instantaneously during production. It also helps to avoid unplanned machine downtime with the early detection of process issues.

Enterprise-wide visibility

ABB systems are designed to provide the rich and meaningful information necessary for best-in-class decision making as well as for additional use in Industry 4.0 applications. In addition to making available all individual data items and summary reports, all operator and maintenance displays can be made accessible to remote users with appropriate security measures and read/write protection in place.

ABB also has companion applications available for external users to analyze and make use of this information, including advanced analytic applications, data aggregation, dashboards, etc.



13

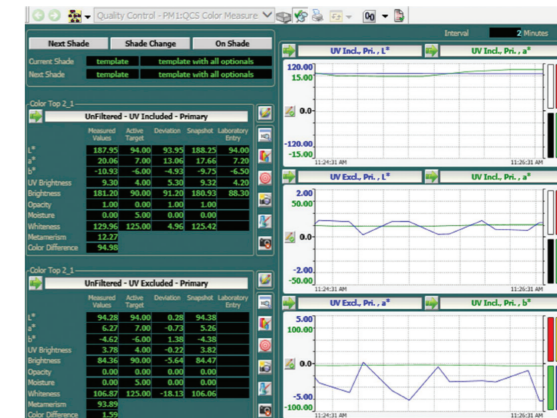

14



15

System integration

Break down barriers for targeted, cost-effective use of information

ABB breaks down the information barriers found in mill and enterprise-wide systems for end-to-end visualization and the use of analytical techniques to optimize productivity. Whether it's bringing quality and production information to the front office and business systems, bringing legacy system interfaces into a modern context, providing advanced analytics for optimization or building new production management applications, ABB has the right solutions.

QCS800xA

ABB Quality Control Solutions are implemented as a functional extension to the System 800xA control platform. The Quality Control System (QCS800xA) can be standalone or work as a totally integrated component with other ABB solutions.

These include paper machine drives and field instrumentation as well as systems for web inspection, lab management, manufacturing execution and distributed control.

The systems fully support Edge computing and localized analytical applications as well as cloud computing and advanced analytical, enterprise-wide solutions.

From relatively simple to extremely complex, ABB has the experience, capabilities and system architecture to scale the system to meet individual needs across the spectrum for automation and integration with new and existing systems.

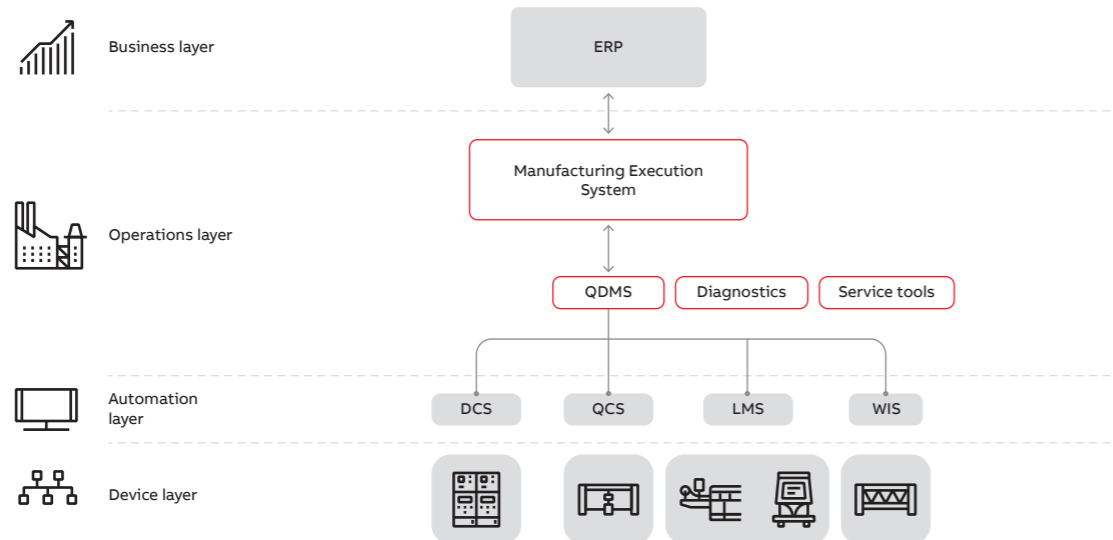

Vertical and horizontal system integration provides the data and visibility needed to improve productivity, quality, asset utilization and more, from a mill to enterprise-wide level.

Best practices for swift decision making

In papermaking operations, it is important to be able to trust and act decisively with the wealth of information available. Because QCS solutions are implemented within the 800xA platform, the data is structured in the necessary format with the rate, method and timing required. ABB's system is therefore able to fully support analysis and model-based decision making, regardless if the data is generated from a physical online sensor, a virtual measurement, process variables or derived from an external source. This also includes model outputs or one in which other algorithms have been applied to the raw data source.

This logical system architecture coupled with good data management practices enable us to develop value-add applications that further benefit the ultimate users of the information. Some examples include:

- Virtual measurements (weight, strength, etc.)
- Sheet break analytics
- Advanced controls (for square point, ash and retention optimization ,etc)
- Data-based root cause analysis for processes and systems
- Integrated Manufacturing Execution Systems
- Integrated analytics and artificial intelligence applications

Integration as the foundation of digital transformation

Even before "Industry 4.0" was formally defined, ABB had been using a common platform for data organization, control and user interface for all of its new products for decades. This means our solutions have an inherent interconnection that makes both application implementation and digital transformation easier. Others are only beginning to tie fundamentally different systems together and many lack the experience to use data in a way that brings real value. With ABB, you get a wealth of automation, digital, and industry expertise within everything we do, driving improved productivity and smarter decision making.

ABB Ability™ System 800xA: Commitment to a common architecture

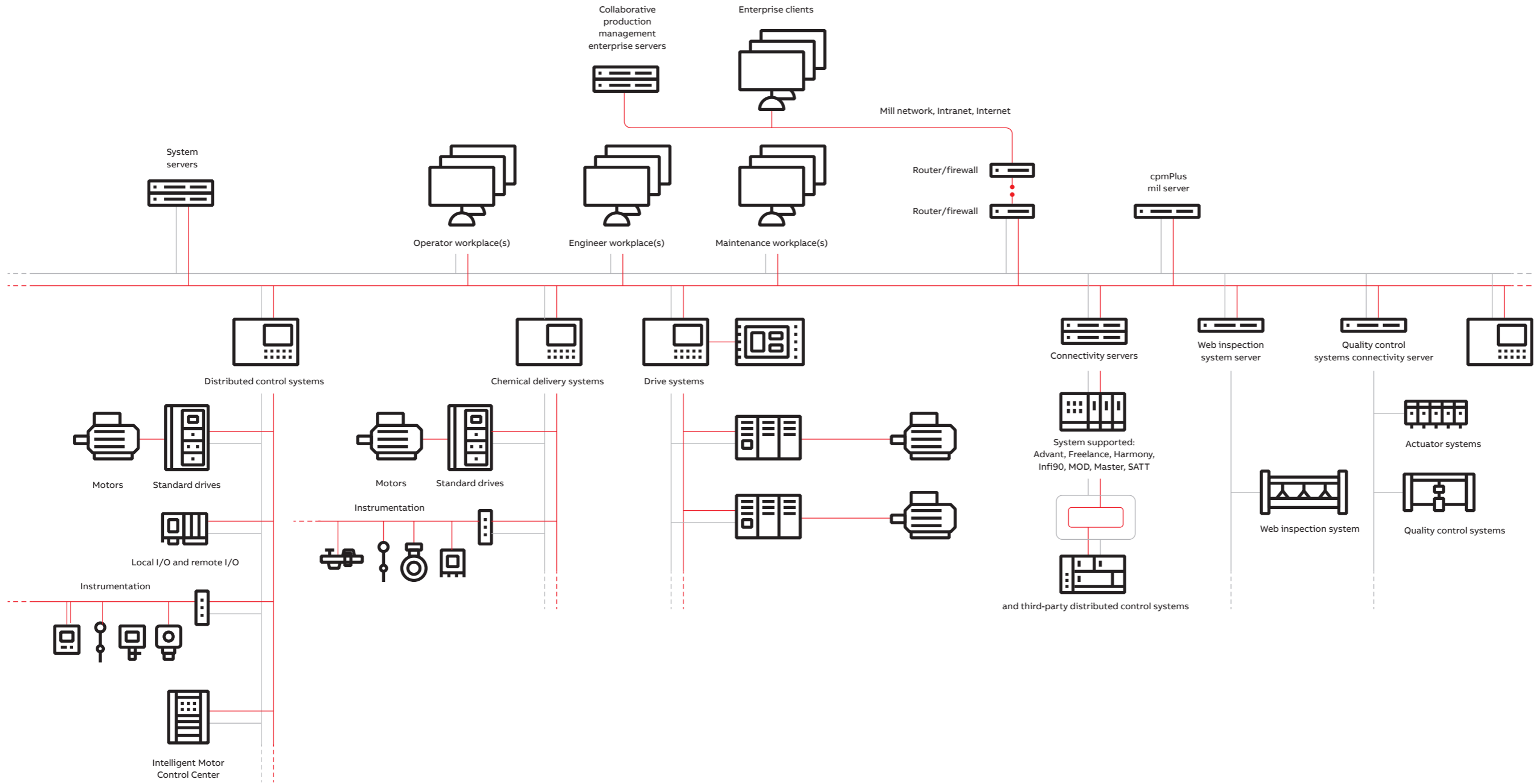

Performance Services

Enhancing process and equipment performance

ABB brings mills a new breed of digital services that not only tap into the vast amount of information available but also leverage the deep industry expertise that enable the delivery of long-lasting value.

ABB Ability™ Performance Services for pulp and paper mills provide a way of operating that allows both ABB and customer personnel to use the same information and communication technology backbone for troubleshooting, technical support, condition and performance monitoring, optimization, and predictive maintenance. Critical equipment and processes can be remotely monitored and optimized by both ABB and customer experts to improve mill performance.

Advanced data processing and analytical applications uncover trends, data patterns and relationships to improve operations.

Alarm monitoring and predictive analytics provide both ABB and mill experts with the necessary information to reduce unplanned downtime. By enabling collaboration in a seamless and fast manner, mills can improve availability, throughput, quality and profitability.

Performance Services are enabled by the ABB Ability™ platform to provide a highly scalable and integrated solution. ABB Ability™ connects ABB and customer experts to actionable data and predictive analytics in a collaborative environment.

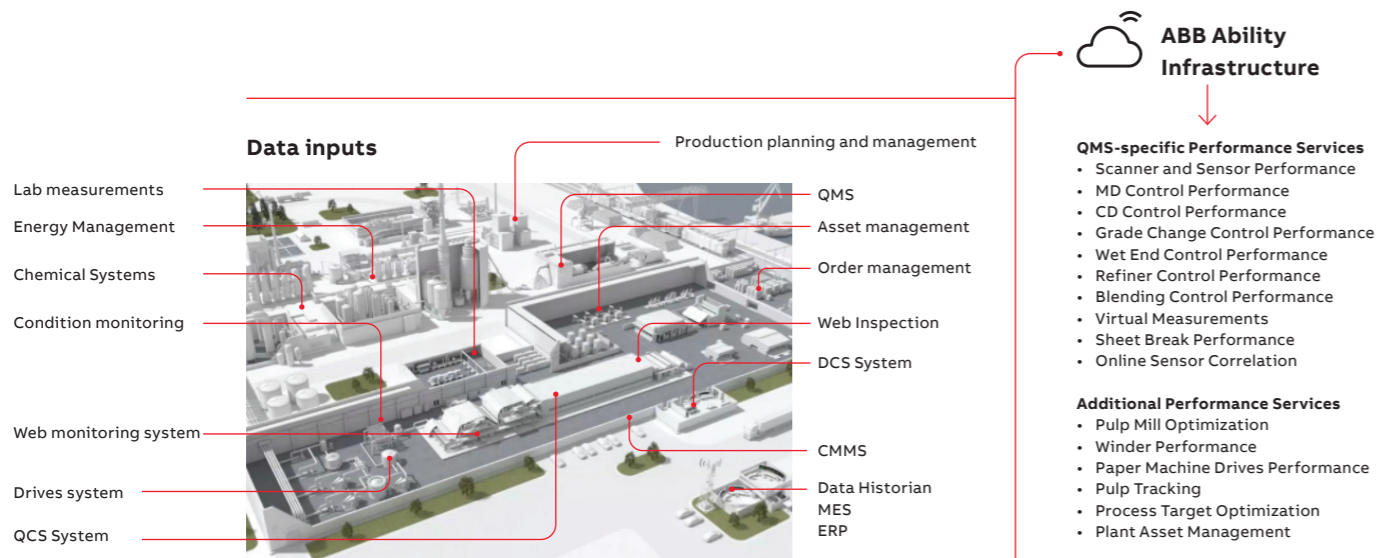

Performance Services are enabled by the ABB Ability™ platform to collect data inputs from across the mill and provide a highly scalable and integrated solutions, some of which are shown here.

Web imaging and monitoring

Easy web defect identification for improved reel, roll and set quality

Promptly identifying and correcting web defects is crucial for minimizing downtime or margin losses. ABB's integrated imaging solutions provide complete quality information to manage web defects, maximizing high-quality production and throughput.

16 ABB's system accurately determines the defect type and enables faster root cause analysis

Accurate web defect detection, imaging, and identification all play crucial roles in process automation, quality control, and operational improvements.

ABB Web Imaging and Web Monitoring Systems are an integral part of a mill's overall quality strategy and production goals. Our high-quality systems help operations through improved reel, roll and set quality and reduced unscheduled downtime while also providing the tools for more thorough and efficient root cause analysis.

For decades, ABB has produced advancements for web image-derived monitoring and reporting. In fact, our commitment to investing in research and development to create advanced and reliable technology is a key reason ABB has delivered imaging solutions to more paper machines than any other supplier.

Both systems are manufactured in-house and developed by ABB's leading quality and web imaging experts who've created a robust system design that enables a long lifecycle, reduced cost of ownership and excellent ongoing performance.

Plus, with easy connection to mill-wide management systems, pulp and paper makers gain full visibility into their product quality and process to ultimately increase profitability.



17

How web imaging and web monitoring contribute to your profitability:



Roll set quality
Determine roll-specific quality values to automatically classify rolls before they reach the winder



Minimizing downtime
Reduce or eliminate downtime caused by web breaks and defects



Root cause analysis
Detect and connect quality issues back to their root cause so remedial action can be taken sooner



Maintaining margins
Avoid losing value and decreasing profit potential due to quality issues and reprocessing

Web Imaging System

ABB's Web Imaging System (WIS) accurately identifies product defects. Using advanced analysis methods, the system quantifies and classifies these defects, providing the customer with total product quality reporting. ABB's WIS can also be used as a platform to provide further image derived data with full sheet formation or surface appearance information.

Based on your specific requirements, the system can be configured for maximum defect detection and accuracy through optimized camera resolution and lighting orientation for full width web inspection.

Each system is configurable to meet customer needs including items like smart defect classification, advanced image analysis for accurate roll qualification, and ABB's patented embedded low-contrast defect detection algorithms (SDI) and streak measurement to find even the smallest defects.

Optional features include:

- Smart Classifier self-classifies through predictive technology, continuously training and optimizing defect classification
- Baby roll classification enables classification down to roll level to optimize product quality
- Web Imaging Dirt Count detects, analyzes, and classifies dirt particles in real time across the full sheet
- Full-Sheet Formation Analysis provides customers with full visibility of uniformity of product
- Real-Time Wrinkle Count detects, classifies and statistically quantifies wrinkle information across the sheet in real time
- Automatic Braking System stops winders and re-reelers exactly on the defect to be inspected or patched, enabling optimized trim planning for maximized profitability

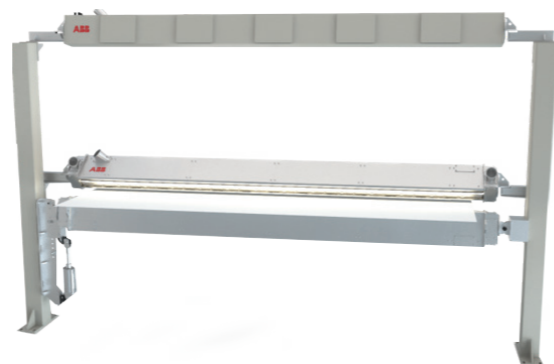

17



Web Monitoring System

ABB's Web Monitoring System provides innovative digital imaging that captures sheet breaks to increase troubleshooting efficiency and improve product quality. Web breaks, or user defined events, are captured and immediately available for operator review allowing fast and simple root cause analysis and process improvements.

ABB Web Monitoring System can provide valuable process data in real time through advanced image analysis using the Feature Extraction and Identification (FEI) application.

WMS features:

- FEI application monitors live data and generates information for a range of machine conditions or issues
- Region of Interest (ROI) captures anomalies in any operator-defined camera view
- Mobile machine analysis with mobile camera configuration
- Minimum 72-hour buffer storage provides opportunities for increased process review
- All events instantly available with user interface presenting tools including timing measurements and geometric measurements for concise analysis

Benefits of WIS and WMS integration

Full integration between ABB Web Imaging and Web Monitoring Systems provides the operator with complete machine information for fast, easy and precise root cause analysis of defects.

The Web Inspection defect map can be displayed within the WMS user interface and tuned to display and target specific defects for video capture. Once a targeted defect occurs, the WMS will automatically download all video images associated to the defect.

Similarly, an operator can also access video playback within the WIS system, generating videos related to a specific defect, all of which expedites root cause analysis. An operator can also access video playback within the WIS system, generating videos related to a specific defect.

This total integration between ABB Web Imaging and Monitoring System is seamless and provides the tools needed to improve product quality.

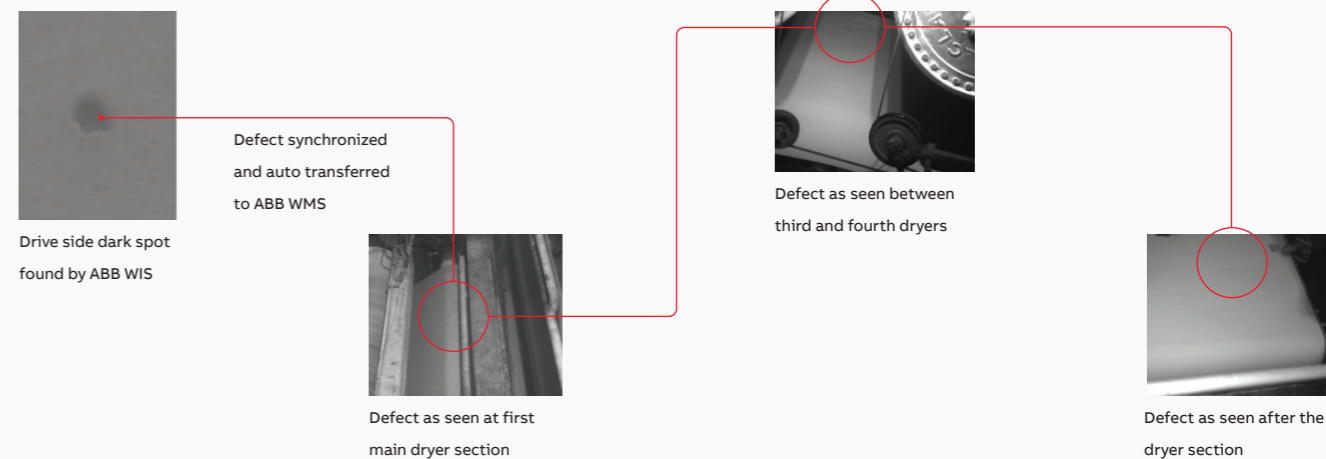

Integration use case: quickly pinpoint root cause of defects

ABB WIS detects a dark spot on the drive side of the sheet (image 1) and automatically transfers details to ABB WMS, which downloads all video related to the defect. Users can view the video and trace back to where the defect is not present. Further review will then locate the root cause of the defect.

Integration of WIS and WMS provides a seamless solution for easy root cause identification

Lifecycle management

Protecting your investment

We are committed to maximizing the usable life of our customers' investment. Our approach to lifecycle management provides our customers with the confidence that there is a well-defined support and a path forward for existing ABB solutions.

With the four phases, ABB enables customers to plan ahead and protect their investment, minimizing maintenance costs and reducing downtime.

Before they move to different stages, ABB shares the lifecycle plan with dates well ahead of the phase ending. The classic and limited phases are active for a minimum of 10 years combined.

- Active**
 - Product marketed and available for sale
- Classic**
 - Functional replacement available
 - Product maintenance phase
- Limited**
 - Product no longer manufactured
 - Supported with best practical effort
- Obsolete**
 - Support not available
 - No longer available for sale or delivery

Most products are active for seven-to-ten years.

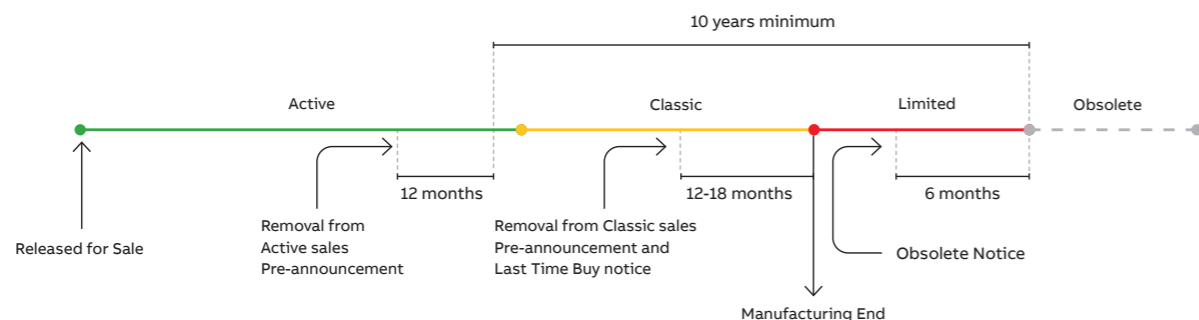

Service agreements

ABB helps customers cut complexity, control costs and maximize capital with our global framework agreements for service. By first assessing your assets and identifying your needs, we can find the right Pulp and Paper Care package for your mill.

Evolution and upgrades

ABB has developed several upgrade paths for our scanners, sensors, actuators and controls. These upgrades can be done in stages to provide a smooth transition from old technology to new systems. This approach not only ensures your investment is protected but also provides enhanced performance capabilities that maximize the value of installed systems and components.

Automation Sentinel

ABB's Automation Sentinel software management program extends the support and value of your existing ABB control software investment, while establishing an affordable path to the next generation of System 800xA functionality. This simple, safe and secure program puts you in control and provides the best overall ROI for all ABB software investments.

Spares

ABB's lifecycle support policy is to make every effort to supply original, high-quality spare parts for at least 10 years after the active lifecycle phase. To further support that commitment, ABB offers several services, including self-assessments, that are designed to optimize your on-site spares and minimize risk of downtime.



Why choose ABB for your quality management needs?

Leading-edge online measurement and control performance from the category creator.



More efficient working methods; information flow improves productivity



Increased (measurable) production through minimal variation



Operational flexibility throughout the grade structure

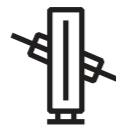

High equipment availability and improved machine runability brings clear productivity gains



Better process insight improves product repeatability



Proven minimum lifecycle cost



Take control of your quality

For any quality challenge your mill is facing, ABB's solutions provide insight into your sheet properties to better control and optimize processes.

For more information, please visit our website:
abb.com/pulpandpaper
or email:
Se-pulpandpaper@abb.com

ABB Ltd. Finnabair Industrial Park
Dundalk, Co. Louth, Ireland
Tel: +353 42 9385100

ABB Engineering Ltd. S.P. Building, No. 5, Lane 369
Chuangye Road Kangqiao Town, Pudong District
Shanghai, 201319, P. R. of China
Tel: +86 21 6105 6777

ABB Inc. 579 Executive Campus Drive
Westerville, Ohio 43082, USA
Tel: +1 614 818 6300

abb.com/pulpandpaper

