

# Three-phase Overvoltage and Undervoltage Relay

# SPAU 130 C

## Product Guide

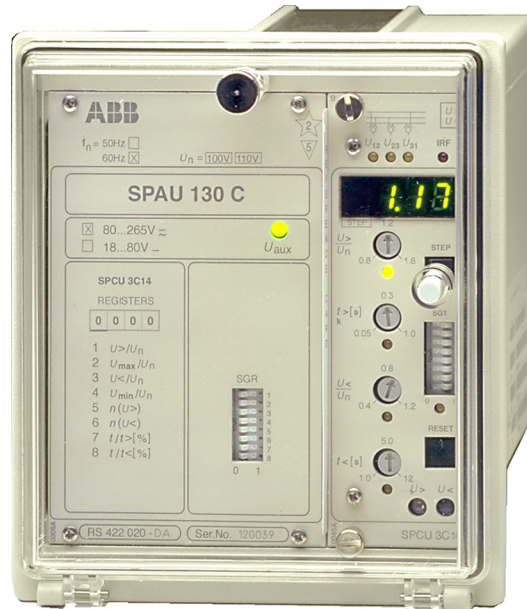



---

## Features

- Combined overvoltage and undervoltage protection relay
- Three-phase definite time or inverse time overvoltage stage
- Three-phase definite time undervoltage stage
- Control input for blocking the function of the undervoltage stage by means of an external control signal
- Automatic blocking of the undervoltage stage on loss of energizing voltage
- Fully field-configurable output relay functions
- Flexible matching of the relay to the intended protection application
- Numerical display of setting values, measured values, recorded fault values, indications, etc.
- Serial interface for bus connection module and fibre-optic substation bus
- Continuous self-supervision of relay hardware and software for enhanced system reliability and availability
- Auto-diagnostic fault indication to facilitate repair of an internal relay fault
- Powerful software support for parameterization and supervision of the relay

---

## Application

The three-phase voltage relay SPAU 130 C is intended to be used for overvoltage and undervoltage protection and supervision in distribution substations. The relay can also be used for overvoltage and undervoltage protection of generators, motors and transformers. Generally, the relay measures the three phase-to-phase voltages of the system, but it can also be programmed for single-phase measurement.

The overvoltage stage can be given definite time characteristic or inverse time characteristic. The undervoltage stage features definite time characteristic alone.

An external control signal can be used to block the operation of the undervoltage stage.

The relay forms a whole including overvoltage stage, undervoltage stage as well as flexible trip and alarm functions.

## Design

The combined overvoltage and undervoltage relay SPAU 130 C is a secondary relay that is connected to the voltage transformers of the object to be protected. The relay generally measures the three phase-to-phase voltages of the system. On operating the relay trips the circuit breaker and/or provides an alarm signal, in accordance with the configuration of the relay.

When one or several of the phase-to-phase voltages exceed the set start value  $U>$  of the overvoltage stage, the overvoltage stage starts and generates a start signal SS1. When, at definite time mode of operation, the set operate time  $t>$  or, at inverse time mode of operation, the calculated operate time  $t>$ , has expired, the overvoltage stage delivers a trip signal TS1. In the same way the undervoltage stage starts and generates a start signal SS2, when the value measured goes below the start value  $U<$ , and when the set operate time  $t<$  has expired, the undervoltage stage operates by generating a trip signal TS2.

The overvoltage and undervoltage relay is generally used as a three-phase relay. But by means of a selector switch the relay can be configured as a single phase relay.

The overvoltage stage can be given definite time characteristic or inverse time characteristic. The inverse time characteristic includes two sets of curves, named A and B.

The undervoltage stage has definite time characteristic. Tripping of the undervoltage stage can be blocked by applying a control signal BS to the external opto-isolated control input of the relay.

The overvoltage and undervoltage relay is provided with two output relays for tripping and three output relays for signalling. One of the signalling relays is dedicated for the self-supervision system of the relay.

## Data communication

The relay is provided with a serial interface on the rear panel. By means of a bus connection module type SPA-ZC 17 or SPA-ZC 21 the relay can be connected to the fibre-optic SPA bus. The bus connection module type SPA-ZC 21 is powered from the host relay, whereas the bus connection module SPA-ZC 17 is provided with a built-in power unit, which can be fed from an external secured power source. The relay communicates with higher-level data acquisition and control systems over the SPA bus.

## Self-supervision

The relay incorporates a sophisticated self-supervision system with auto-diagnosis, which increases the availability of the relay and the reliability of the system. The self-supervision system continuously monitors the hardware and the software of the relay. The system also supervises the operation of the auxiliary supply module and the voltages generated by the module.

When the self-supervision system detects a permanent internal relay fault, the IRF indicator on the relay front panel is lit. At the same time the output relay of the self-supervision system operates and a fault message is transmitted to the higher-level system over the serial bus. Further, in most fault situations, a fault code is shown in the display of the protection relay module. The fault code indicates the type of the fault that has been detected.

## Auxiliary supply voltage

The auxiliary supply of the relay is obtained from an internal plug-in type power supply module. Two auxiliary power module versions are available: type SPTU 240S1 for the supply voltage range 80...265 V ac/dc and type SPTU 48S1 for the supply voltage range 18...80 V dc. The power supply module forms the internal voltages required by the protection relay and the I/O module.

Technical data

Table 1: Energizing inputs

Terminals	13-14, 16-17, 19-20	13-15, 16-18, 19-21
Rated voltage $U_n$	100 V	110 V
Continuous withstand	$2 \times U_n$	$2 \times U_n$
Power consumption at rated voltage $U_n$	<0.5 VA	
Rated frequency $f_n$ , according to order	50 Hz or 60 Hz	

Table 2: Output contact ratings

Type of contact		Tripping	Signalling
Terminals		65-66, 68-69	70-71-72, 77-78, 80-81
Rated voltage		250 V ac/dc	
Thermal withstand capability	Carry continuously	5 A	5 A
	Make and carry for 0.5 s	30 A	10 A
	Make and carry for 3 s	15 A	8 A
Breaking capacity for dc, when the control/signalling circuit time constant $L/R \leq 40$ ms, at the control voltages	220 V dc	1 A	0.15 A
	110 V dc	3 A	0.25 A
	48 V dc	5 A	1 A

Table 3: Control input, communication and power supply

External control input	Terminals	10-11		
	Control voltage level	18...265 V dc or 80...265 V ac		
	Power consumption when input activated	2...20 mA		
Data communication	Transmission mode	Fibre-optic serial bus		
	Data code	ASCII		
	Selectable data transfer rates	300, 1200, 2400, 4800 or 9600 Bd		
	Fibre-optic bus connection module, powered from the host relay	for plastic fibre cables	SPA-ZC 21BB	
		for glass fibre cables	SPA-ZC 21MM	
	Fibre-optic bus connection module with a built-in power supply unit	for plastic fibre cables	SPA-ZC 17BB	
for glass fibre cables		SPA-ZC 17MM		
Auxiliary supply modules	Power supply and I/O modules and voltage ranges	SPTU 240S1	80...265 V ac/dc	
		SPTU 48S1	18...80 V dc	
	Power consumption	under quiescent conditions	~4 W	
		under operating conditions	~6 W	

Technical data (cont'd)

**Table 4: Overvoltage and undervoltage relay module SPCU 3C14**

Overvoltage stage U>	Start voltage U>	0.8...1.6 × U <sub>n</sub>		
	Start time, preset values	0.1 s or 30 s		
	Operate time at definite time operation characteristic	0.05...100 s		
	Time multiplier k> at inverse time operation characteristic	0.05...1.00		
	Reset time, typically	60 ms		
	Drop-off/pick-up ratio, typically	0.97		
	Operate time accuracy	at definite time characteristic and start time accuracy	±2% of set value or ±25 ms	
		at inverse time mode of operation	±25 ms or accuracy obtained at a ±3% variation of the input voltage	
Operation accuracy	±3% of set value			
Undervoltage stage U<	Start voltage U<	0.4...1.2 × U <sub>n</sub>		
	Start time, preset values	0.1 s or 30 s		
	Operate time at definite time operation characteristic	1...120 s		
	Reset time, typically	60 ms		
	Reset ratio, typically	1.03		
	Operation time accuracy and start time accuracy	±2% of set value or ±25 ms		
	Operation accuracy	±3% of set value		

**Table 5: Tests and standards**

Test voltages	Dielectric test voltage (IEC 60255-5)	2.0 kV, 50 Hz, 1 min
	Impulse test voltage (IEC 60255-5)	5 kV, 1.2/50 μs, 0.5 J
	Insulation resistance (IEC 60255-5)	>100 MΩ, 500 V dc
Interference tests	High-frequency (1 MHz) disturbance test (IEC 60255-22-1), common mode	2.5 kV
	High-frequency (1 MHz) disturbance test (IEC 60255-22-1), differential mode	1.0 kV
	Fast transients (IEC 60255-22-4, class III and IEC 61000-4-4), power supply inputs	4 kV, 5/50 ns
	Fast transients (IEC 60255-22-4, class III and IEC 61000-4-4), other inputs	2 kV, 5/50 ns
	Electrostatic discharge (IEC 60255-22-2 and IEC 61000-4-2), air discharge	8 kV
	Electrostatic discharge (IEC 60255-22-2 and IEC 61000-4-2), contact discharge	6 kV
Environmental conditions	Service temperature range	-10...+55°C
	Transport and storage temperature range (IEC 60068-2-8)	-40...+70°C
	Damp heat test (IEC 60068-2-3)	<95%, +40°C, 96 h
	Relative humidity (IEC 60068-2-30)	93...95%, +55°C, 6 cycles
	Degree of protection by enclosure when panel mounted	IP 54
	Weight	3 kg

Block diagram

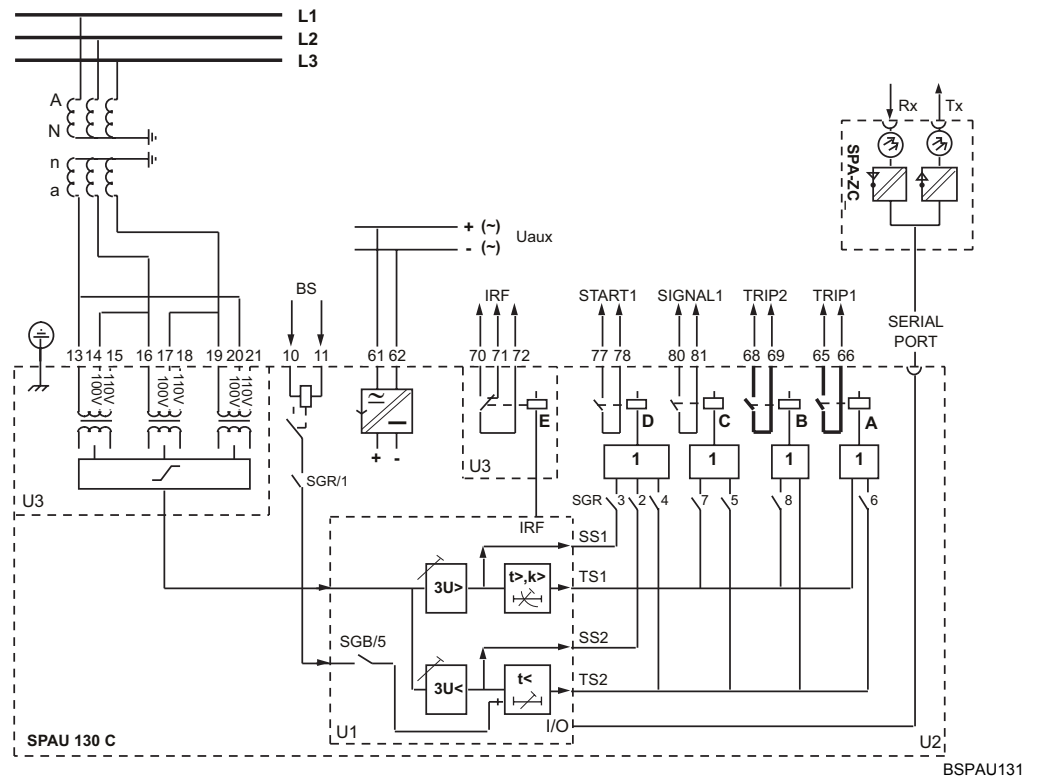

Fig. 1 Block diagram and sample connection diagram

Mounting and dimensions

Flush mounting

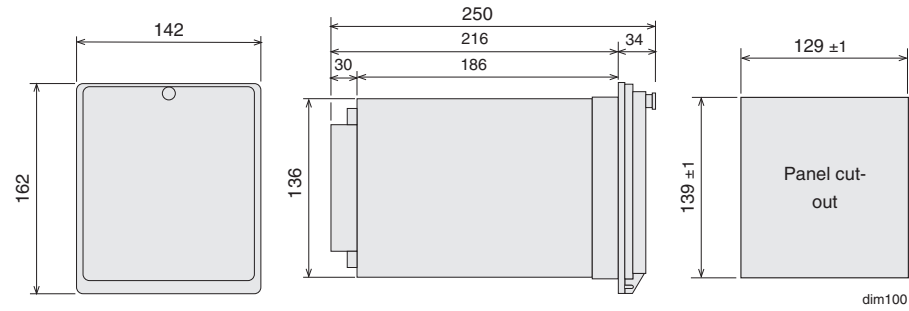

Fig. 2 Flush-mounting relay case (dimensions in mm)

Semi-flush mounting

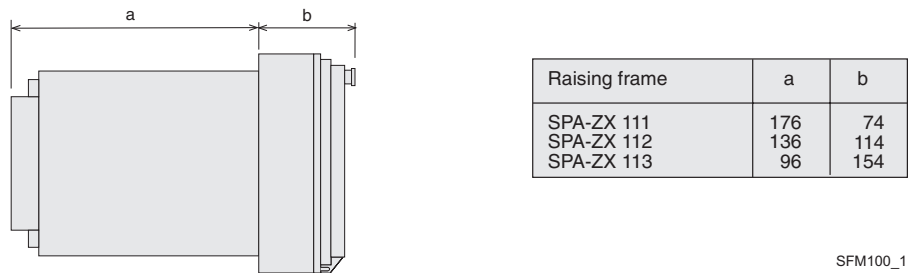

Fig. 3 Semi-flush mounting relay case (dimensions in mm)

Mounting in 19 inch cabinets and frames

An ancillary mounting plate, height 4U (~177 mm), is recommended to be used when the protection relays are to be mounted in 19 inch frames or cabinets. The ancillary mounting plate type SPA-ZX 104 accommodates three relays, type SPA-ZX 105 two relays and type SPA-ZX 106 one relay.

Projecting mounting

When projecting mounting is preferred, a relay case type SPA-ZX 110 is used. The relay case for projecting mounting is provided with front connectors.

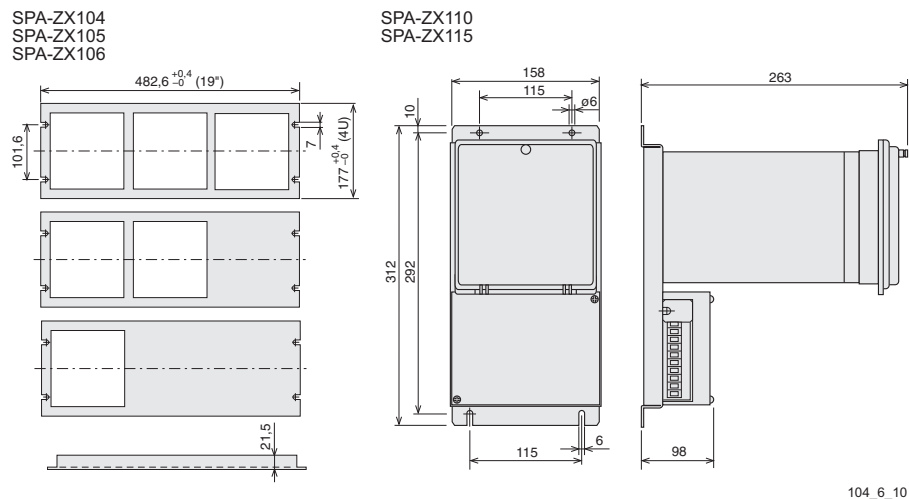

Fig. 4 Mounting cabinets and frames as well as projecting mounting (dimensions in mm)



**Ordering**

**When ordering, please specify:**

Ordering information	Ordering example
1. Type designation and quantity	SPAU 130 C, 5 pieces
2. Order number	RS 422 020-AA
3. Rated values	$U_n = 110 \text{ V}$ , $f_n = 50 \text{ Hz}$
4. Auxiliary voltage	$U_{aux} = 110 \text{ V dc}$
5. Accessories	-
6. Special requirements	-

**Order numbers**

Three-phase overvoltage and undervoltage relay SPAU 130 C without test adapter	RS 422 020-AA, CA, DA, FA
Three-phase overvoltage and undervoltage relay SPAU 130 C including test adapter RTXP 18	RS 422 220-AA, CA, DA, FA
The last two letters of the order number indicate the rated frequency $f_n$ and the auxiliary voltage $U_{aux}$ of the relay as follows:	AA equals $f_n = 50 \text{ Hz}$ and $U_{aux} = 80...265 \text{ V ac/dc}$
	CA equals $f_n = 50 \text{ Hz}$ and $U_{aux} = 18...80 \text{ V dc}$
	DA equals $f_n = 60 \text{ Hz}$ and $U_{aux} = 80...265 \text{ V ac/dc}$
	FA equals $f_n = 60 \text{ Hz}$ and $U_{aux} = 18...80 \text{ V dc}$

**References**

**Additional information**

Manual "Three-phase overvoltage and undervoltage relay SPAU 130 C"	1MRS 750638-MUM EN
--------------------------------------------------------------------	--------------------



**ABB Oy**  
Distribution Automation  
P.O. Box 699  
FI-65101 Vaasa, FINLAND  
Tel +358 10 22 11  
Fax +358 10 224 1094  
[www.abb.com/substationautomation](http://www.abb.com/substationautomation)