

# Rail traction

## Synchronous generators for diesel-electric locomotives



ABB's unique, vibration resistant traction generators boost the reliability of modern low emission engines. The compact, high performance generators cover powers from 1 to over 3 MW with efficiencies up to 96.9%. ABB's proven traction generator technology comes from an IRIS certified plant.

— 01 ABB's complete rail portfolio covers systems and components from AC and DC substations to motors and generators, traction transformers, and converters. Other ABB products include LV and MV components, surge arresters, Static Frequency Converters and turbochargers. All our products are backed by local service around the world.

### Vibration resistant design

The generators' innovative design is extremely vibration resistant, eliminating the need for long double-bearing constructions and additional couplings. Our standard single bearing arrangement can withstand the higher torsional vibrations of the shaft line induced by today's high compression engines. This enables locomotive builders to minimize the space requirement. The robust structure offers reduced maintenance and ensures a long and trouble-free operating life, increasing overall genset lifetime. High efficiency ABB generators also reduce diesel consumption, further minimizing emissions.

### Flexibility

ABB traction generators are designed for high performance and reliability in a compact and easily installed unit. Two standard features – the single-bearing mounting configuration and forced

ventilation cooling option – both help to optimize the overall size.

Design variants are available for operation in extreme environmental conditions (ambient temperature range and working altitude).

The terminals can be located in a dedicated terminal box or on the bearing end shield.

The generators use a reliable built-in brushless DC exciter with easy maintenance access for the diode bridge. ABB's state-of-the-art Automatic Voltage Regulator (AVR) provides high accuracy (+/- 0.25%) and uses dependable Modbus communications to save both cabling costs and commissioning time. This digital dual channel AVR – which is separately delivered – also allows redundancy.

Based on the same generator core, ABB can offer customized solutions for the mounting and shaft end configuration (single/double bearing), and for different ambient conditions, voltage outputs, thermal/insulation classes, and others.

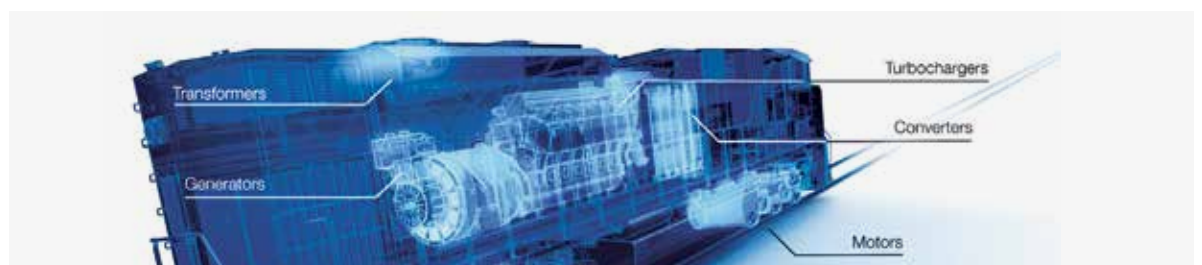

## Innovative, application optimized rotor design

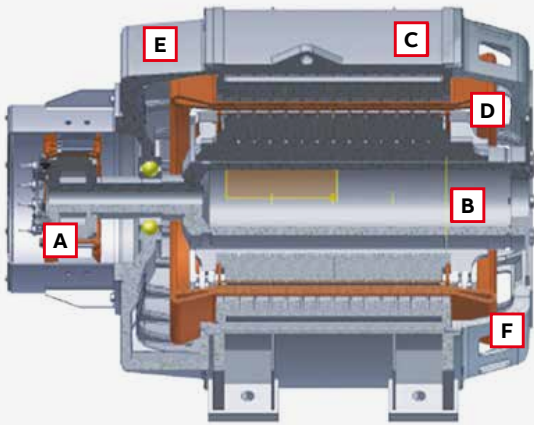

01

01

- A. Rotor exciter with rectifier
- B. Rotor shaft
- C. Frame
- D. Wound stator
- E. NDE shield
- F. DE shield

02 IRIS

03 UNI EN 15085-2

### Application specific engineering

ABB rail traction generators are based on over 120 years' experience in demanding motor and generator applications. They also benefit from ABB's long-term collaboration with the principal diesel engine manufacturers and locomotive builders in Europe and the US. These generators deliver performance and reliability while meeting the challenging size and weight requirements of today's locomotive designs. Dedicated calculation tools and FEM (finite element method) analysis were used for the electrical dimensioning, and also helped to verify the mechanical properties through structural analysis. The stator, frame and end shields were carefully analyzed to study the effects of static and fatigue loads. To ensure optimum integration and reliability with diesel engines, the mechanical calculations were undertaken jointly with the diesel engine manufacturer.

### Proven reliability

Both the product and the process were thoroughly analyzed and FMEAs (Failure Mode and Effect Analysis) carried out in order to mitigate possible risks and thereby further improve the generators' reliability and lifetime. Endurance testing was performed with a generator coupled to a diesel engine to verify the behavior of shaft line components like the generator rotor, flex plate, flywheel and engine crankshaft, including the relevant bearing. The evaluated MTBF (Mean Time Between Failure) fully satisfies IRIS certification criteria. The design ensures good maintainability with easy access to components subjected to periodic checks.

### Quality in-built

Quality in ABB generators originates from our design, manufacturing processes and the materials we use. We source our purchases from reliable suppliers only and perform thorough testing in all phases of manufacturing. ABB's quality assurance system for traction generators fulfills the requirements of IRIS certification and the relevant standards. The traction generator plant is EN15085 and IRIS certified, and certification has to be renewed annually. In addition to auditing and qualification of the supply chain, FAIs (First Article Inspections) are performed on critical components every time the design, supplier or manufacturing process changes. All production phases are monitored and reported according to the Quality Control Plan agreed with customers.

### Sustainability

In line with ISO 14001, the generators' design and manufacturing principles are based on environmental sustainability and waste reduction. High electrical efficiency enables energy consumption and thus emissions to be reduced under any operating conditions. The generators' innovative design concept and carefully selected materials also enable component recycling to be maximized and raw material utilization to be reduced.

## Global manufacturing with local support

### Low Total Cost of Ownership

By keeping the total investment and running costs down, and reducing the risk and cost of not running, ABB traction generators offer a low Total Cost of Ownership. This enables short payback times and helps operators to maximize profits.

### Cost of investment

Focusing on the purchase price alone can quickly put cost calculations 'on the wrong track'. ABB traction generators offer easy installation with local support, helping OEMs to keep their projects on budget. The compact single-bearing design and flexible configuration minimize installation and cabling work. With factories around the world, ABB can deliver high local content for the entire traction chain, ensuring a low total investment cost.

### Cost of running

The high efficiency generators help to lower emissions by cutting diesel consumption. Smooth, vibration resistant operation with lower inertia minimizes the stress on the diesel engine, extending the genset's maintenance interval and lifetime. These factors help to keep running costs down.

### Cost of not running

ABB's proven technology offers high availability. The generators are designed for a long lifetime in even the most challenging conditions – from scorching deserts to icy, high altitude locations. Easy servicing, local support around the world and short lead times for spares make for a low cost of not running.

- Compact single-bearing design
- Flexible, easy installation
- Long genset maintenance interval

### Generator power

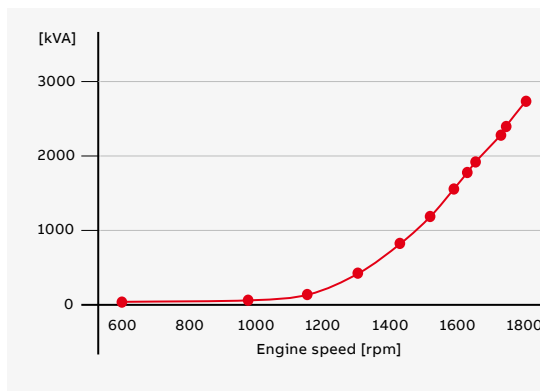

### Generator efficiency

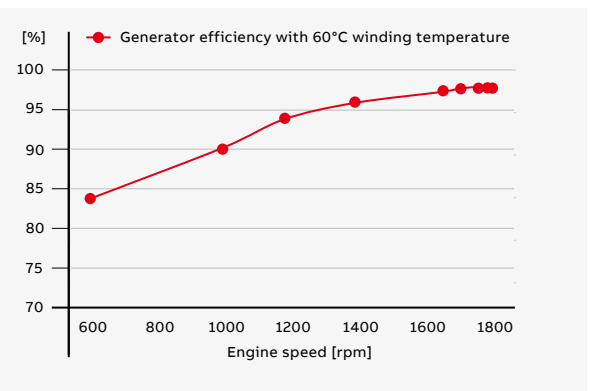

ABB's experience and extensive R&D resources enable customers to design modern ultralight locomotives for demanding high-speed rail projects. We can equip the entire diesel-electric traction chain, offering perfectly matching components to maximize the system reliability.

### WGX 500 – 560 pb6 traction generators

#### Main specifications

Rated power range	1 – 3.3 MW
Output voltage range	400 - 2400V
Operating speed range	600 – 1800 rpm, (6-pole)
Efficiency	96.9%, at 1800 rpm
Ambient temperature range	- 20 ... +40°C, (max. 1000 m amsl)
Insulation / temperature class	up to C / H
Mounting	IM 2405/single bearing IM 2401/double bearing (as option)
Cooling	IC17 forced ventilation, IC01 self ventilation (as option)
Main standard compliance	IEC 60034 – IEC 61373
Certification	IRIS (International Railway Industry Standard)



---

Reliable ABB high performance traction generators. Proven technology with low total cost of ownership, from the leading, independent, IRIS certified supplier.

#### **Your reliable partner**

ABB is a leader in power and automation technologies that enable utility and industry customers to improve their performance while lowering environmental impact. The ABB group of companies operates in around 100 countries and employs about 150,000 people. ABB is the technology and market leader in motors and generators for all industrial and marine applications. We have supplied tens of thousands of large motors and generators to customers all over the world, based on more than 120 years of experience in the widest range of solutions. ABB's global engineering, manufacturing and service network enables our customers to produce power reliably and efficiently wherever they operate.

---

**ABB S.p.A.**  
**Robotics and Motion Division**  
Via L. Lama, 33  
20099 Sesto San Giovanni (MI)  
Tel.: +39 02 2415 0000

[new.abb.com/motors-generators](http://new.abb.com/motors-generators)

---

We reserve the right to make technical changes or modify the contents of this document without prior notice. With regard to purchase orders, the agreed particulars shall prevail. ABB AG does not accept any responsibility whatsoever for potential errors or possible lack of information in this document.

We reserve all rights in this document and in the subject matter and illustrations contained therein. Any reproduction, disclosure to third parties or utilization of its contents – in whole or in parts – is forbidden without prior written consent of ABB AG. Copyright© 2018 ABB  
All rights reserved