

# Just push it

## Push-in Spring motor starting solution



- Faster than ever installation
- Easier than ever wiring
- Reliable as ever connections

—

**With the new complete Push-in Spring motor starting solution, one push is all you need for extremely fast wiring. No tool is required, so you can save up to 50% wiring time with Push-in Spring compared to conventional spring solutions. And the connections are just as reliable. So for speed, ease and reliability, just push it.**

---

# Push-in Spring motor starting solution

<b>3</b>	<b>Presentation</b>
<b>6</b>	<b>Overview</b>
<b>12</b>	<b>Manual motor starters</b>
<b>25</b>	<b>AF..K contactors</b>
<b>49</b>	<b>NF..K contactor relays</b>
<b>63</b>	<b>Accessories</b>



# Just push it

## Push-in Spring motor starting solution

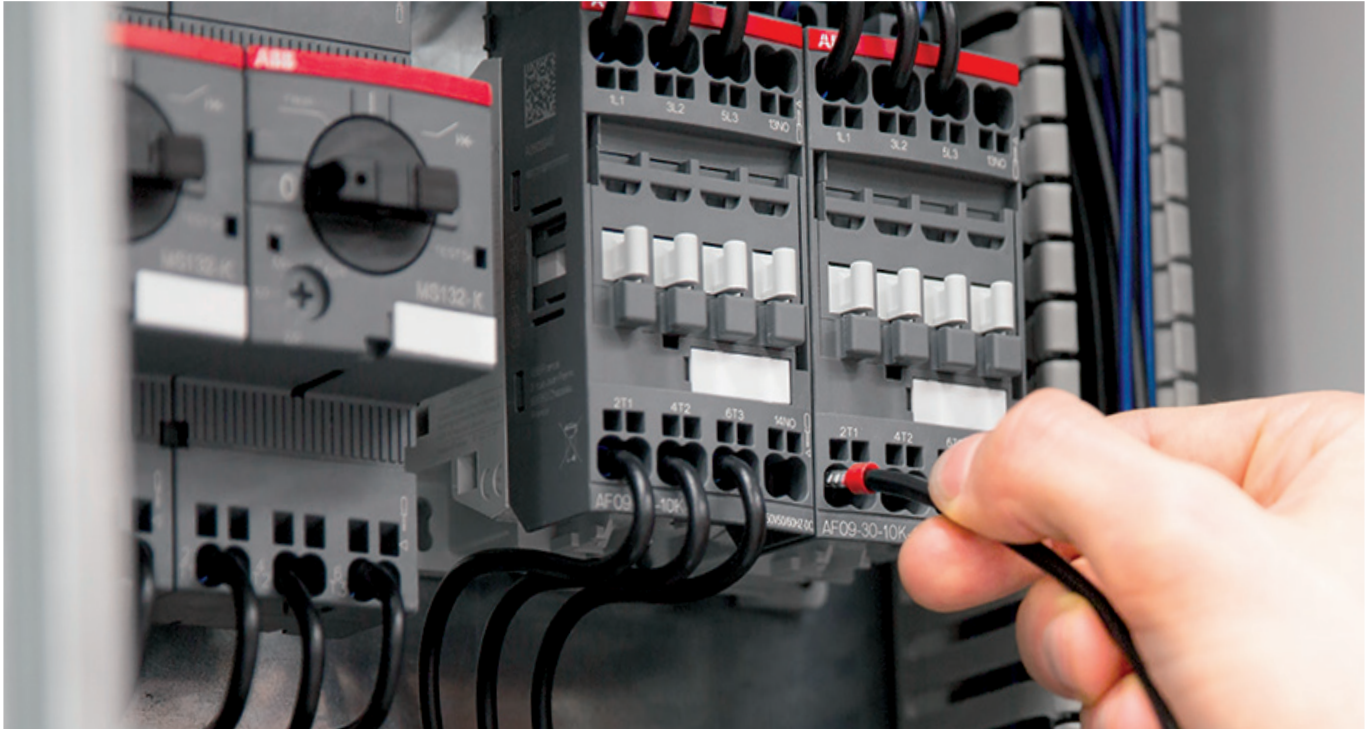

With the new complete Push-in Spring motor starting solution, one push is all you need for extremely fast wiring. No tool is required, so you can save up to 50% wiring time with Push-in Spring compared to conventional spring solutions. And the connections are just as reliable. So for speed, ease and reliability, just push it.



### Speed up your projects

#### Faster than ever installation

Imagine a motor starting solution that's twice as fast to install. With Push-in Spring, you no longer need to imagine – it's a reality. Push-in mode allows you to insert both ferruled and rigid cables without the need to use any tools, boosting your productivity like never before.



### Easy to install

#### Easier than ever wiring

Push-in Spring technology opens up new possibilities. With its unmatched ease of use, wiring becomes far more intuitive. This eliminates the need for special training and reduces the chance of wiring error. What possibilities will it open up for you?



### Continuous operation

#### Reliable as ever connections

The speed and ease of Push-in Spring comes with the added reassurance of connections that are as reliable as ever. This gives you complete peace of mind when using the Push-in Spring motor starting solution.

# Just push it!

## The next evolution in motor starter solutions is here.

So up to 30 hp, one push is all you need!

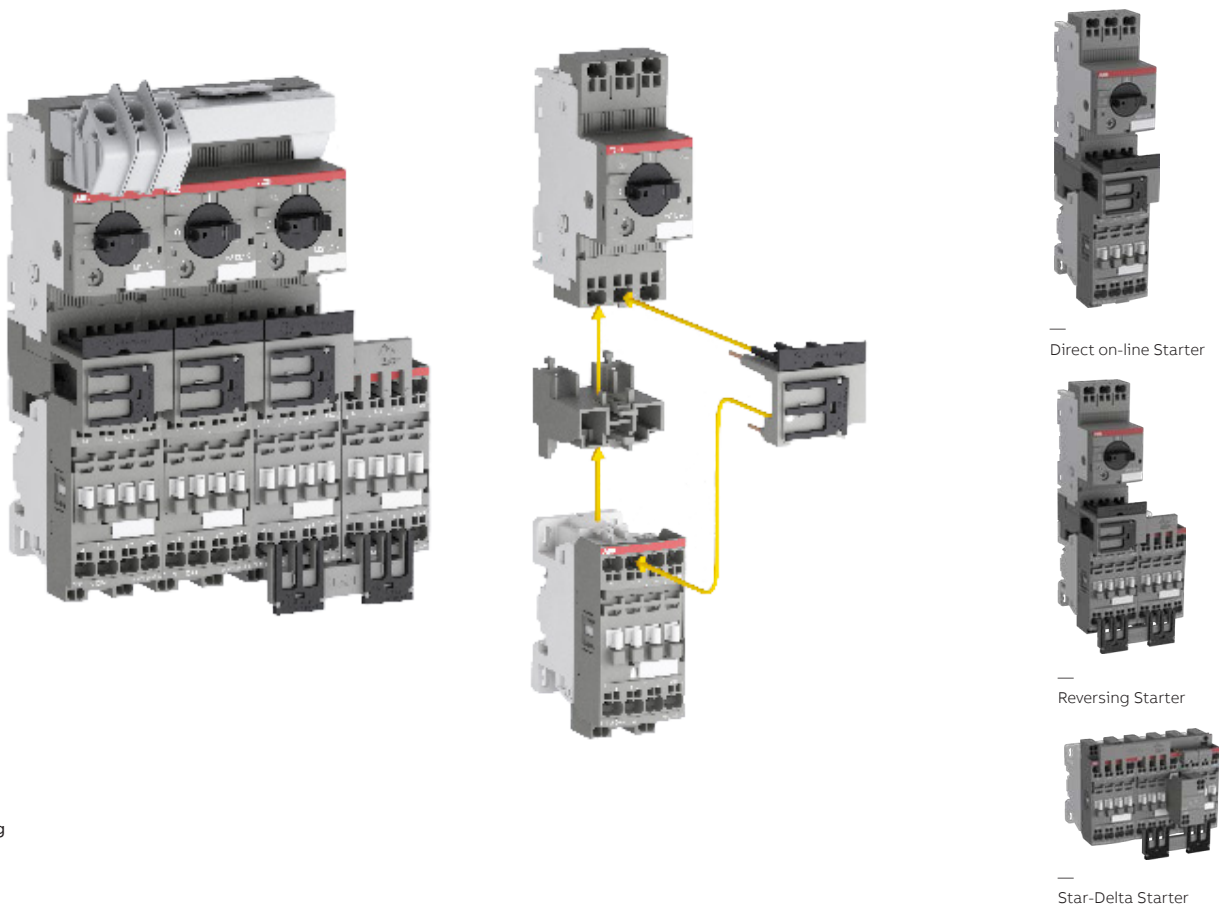

Save up to 50% wiring time with Push-in Spring compared to conventional spring solutions. And the connections are just as reliable. So for speed, ease and reliability, just push it.

Also available with Push-in technology

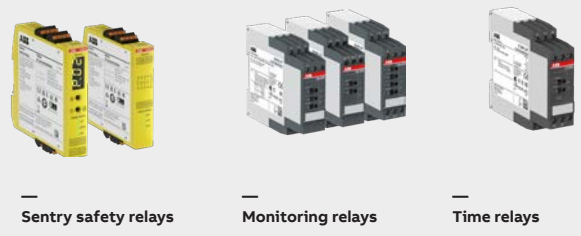

— Sentry safety relays      — Monitoring relays      — Time relays

## Benefits / Features

- Fast and intuitive wiring
- Tool-free mounting
- Vibration & shock proof
- Robust design for higher up-time
- Future proof connection technology
- Terminals accessible from the front
- One-hand mounting
- 2-in-1 Push-in / Spring
- Higher connection capacity
- No mounting plate required for starters
- Enabled for automated wiring

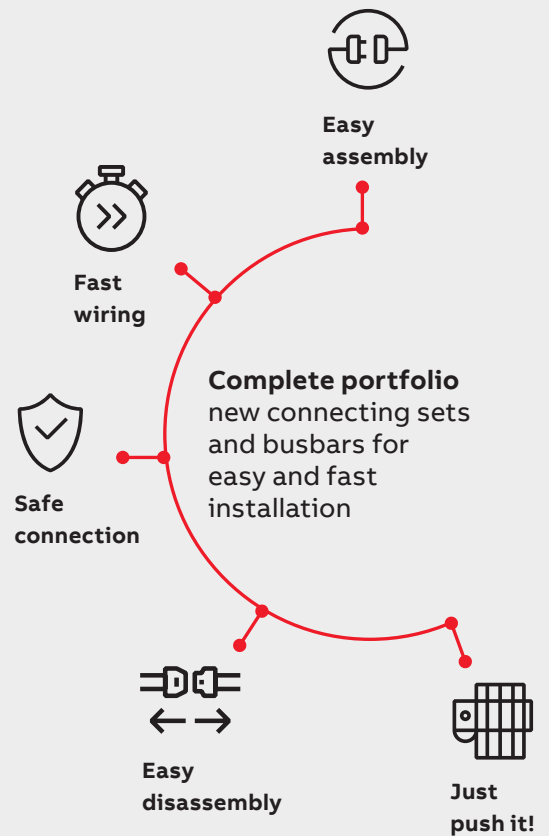

CA4..K, CAL4-11K 1, 2 and 4 pole auxiliary contacts

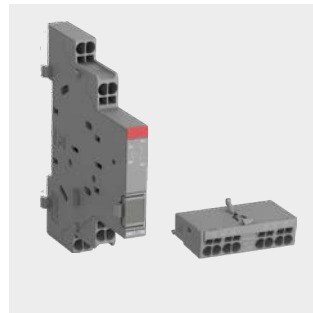

HK1-K, HKF1-K auxiliary contacts



SK1-K and SK1-ARK signaling contacts



PS1-...-65K busbars for 2, 3, 4 or 5 manual motor starters



TS1-M3-K terminal spacer for UL Type E/F combination motor controllers



BEA16-4KF and BEA38-4KF connecting links with manual motor starters



BER16-4KF and BER38-4KF connecting links for reversing starters



BEY16-4KF and BEY38-4KF connection sets for Star-Delta starters



VEM4K electrical and mechanical interlock

# Faster than ever installation



## 2-in-1 connection

For the very first time, ABB's 2-in-1 connection allows you to use ferruled and rigid cables (Push-in mode) or cables without ferrules (Spring mode) in the same terminal. In Push-in mode, cables can be inserted by just simply pushing them in by hand.

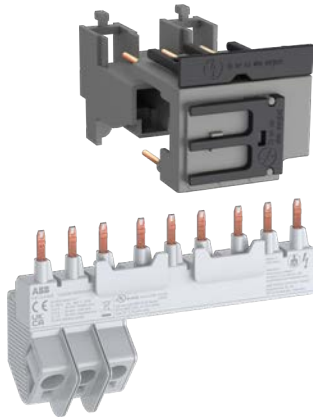

## Smart accessories

100% tool-free connecting kits and busbars significantly reduce installation time.



## Complete solution

High connection capacities are optimized for motor starting solutions up to 30 hp 600 V and 45 A general use. This includes short-circuit fuseless protection up to 65 kA. Push-in Spring accessories can be also mounted on the standard screw range of manual motor starters and contactors.

## Easier than ever wiring



### Intuitive wiring

With Push-in Spring, all cables, busbars and connecting links use the same round shape entry, whilst the square terminals are clearly marked with screwdriver symbols. The result? Wiring and de-wiring that's intuitive and easily repeatable without cabling error, with little to no training required.



### Just one screwdriver required

For de-wiring, only one screwdriver size is needed for the entire range. No twisting or turning is required either, so there's less chance of damage to the terminals and to your installation as a whole.

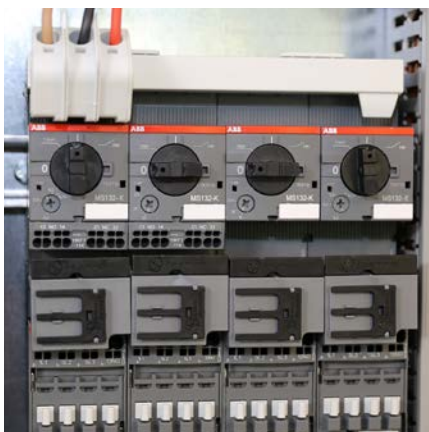

### Automated wiring

The Push-in Spring motor starting solution features 90° cable insertion for all terminals. Front access to terminals aids smooth, robust insertion of cables and makes automated robot wiring possible.

## Reliable as ever connections

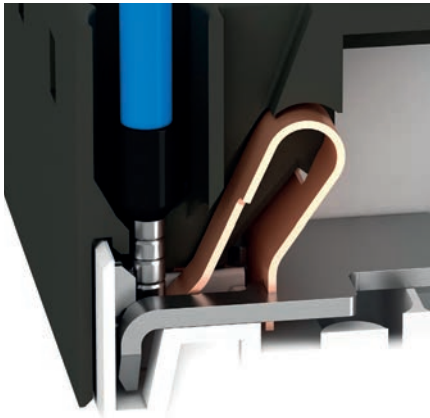

### Robust electrical contact

The special spring design guarantees excellent electrical contact. The design provides strict control of contact strength, independent from operator, giving you complete assurance.



### Vibration-proof

You can count on Push-in Spring connections, even in harsh environments. Push-in Spring technology has been shock and vibration tested according to IEC 60068-2-27 and IEC 60068-2-6 standards.



### No need to re-tighten

With self-tightening terminals, there's no need to re-tighten after transportation or during the life cycle of the product. High connection strength is guaranteed throughout the whole lifetime of the device.

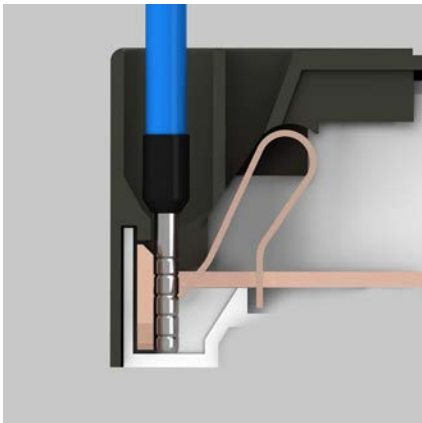

### Push-in mode

Connect rigid cables or ferruled cables simply by pushing them into the cable holes – no need to use any tools. Push-in mode saves up to 50% wiring time compared to conventional spring solutions and makes installation a breeze. Benefit from intuitive wiring, self-tightening terminals and less chance of wiring error.

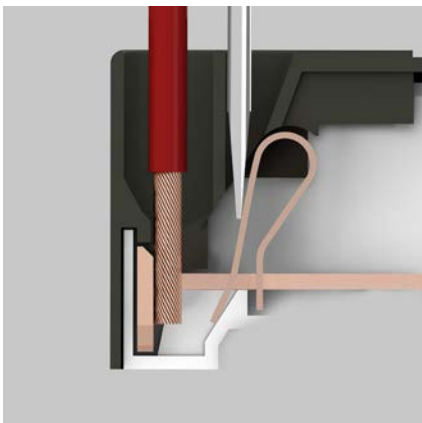

### Spring Mode

This mode is used for small cable cross-sections or for cables without ferrules. It is also used for de-wiring the solution. Before inserting the cable, simply push a screwdriver into the clearly marked holes to open the terminal. ABB's Spring mode is easier to use than conventional spring technology, with less chance of damage to terminals as no twisting or turning is required.

# Push-in Spring solution

## Complete range, complete efficiency

The Push-in Spring motor starting solution products provide you with a range of benefits.



### 2-in-1

Benefit from both Push-in mode and Spring mode and use ferruled cables or cables without ferrules in the same terminal.



### Tool-free connecting links

100% tool-free mounting connecting links.



### Compatible with screw range

Mount accessories for control circuits on the screw range up to 75 hp 600 V on manual motor starters and up to 75 hp 600 V, 115 A General use on contactors.

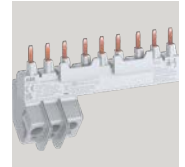

### Tool-free busbars

Parallel connection of manual motor starters without the need for tools (also certified for UL Type E/ Type F applications)



### Just one tool for everything

You only need a 3 mm screwdriver in Spring mode as well as for de-wiring the complete solution.



### Higher connecting capacity

The solution ranges up to 30 hp 600 V and 45 A 600 V general use.

# 3-pole contactors and motor protection



AC / DC Control supply			Type	AF09..K	AF12..K	AF16..K	AF26..K	AF30..K	AF38..K
IEC	AC-3 Rated operational power	$\theta \leq 60\text{ }^\circ\text{C}$ , 380 - 400 V	kW	4	5.5	7.5	11	15	18.5
	Rated operational current	380 - 400 V	A	9	12	18	26	32	38
	AC-1 Rated operational current	$\theta \leq 40\text{ }^\circ\text{C}$ , 690 V	A	25	28	30	45	50	50
UL/CSA	3-phase Motor Rating	550 - 600 V	hp	7.5	10	15	20	25	30
	General Use Rating	600 V	A	25	28	30	42	45	45
NEMA	NEMA size			00	0	-	1	-	-

## Main accessories for contactors

Auxiliary contact blocks		Front mounting	CA4-10K (1 N.O.) CA4-01K (1 N.C.)
		Side mounting	CAL4-11K
Interlocking units		Mechanical	VM4
		Mechanical / Electrical	VEM4K
Surge protection			Built-in surge protection

## Main accessories for manual motor starters

Connecting link for contactor mounting		BEA16-4KF	BEA38-4KF
Auxiliary contact blocks	Front mounting	HKF1-..K (1 N.O. + 1N.C.) (2 N.O.)	
	Side mounting	HK1-..K (1 N.O. + 1N.C.) (2 N.O.) (2 N.C.)	
Signaling contact	For trip alarm	SK1-..K (1 N.O. + 1N.C.) (2 N.O.) (2 N.C.)	



---

# Manual motor starters

<b>14</b>	<b>Ordering details - 0.10 to 32 A with thermal and electromagnetic protection</b>
<b>15</b>	<b>Technical data</b>
<b>22</b>	<b>Main accessories</b>

# MS132-K manual motor starters with Push-in Spring terminals

0.10 to 32 A – with thermal and electromagnetic protection



2CDC241025V00017

The MS132-K series is a compact and powerful range for motor protection up to 25 hp 600 V / 32 A with a width of only 45 mm. The innovative Push-in Spring terminals enable tool-free wiring and eliminate the need for routine re-tightening.

The MS132-K also has a clear and reliable indication of fault in a separate window in the event of short-circuit tripping. Further features are the build-in disconnect function, temperature compensation, trip-free mechanism and a rotary handle with a clear switch position indication.

The manual motor starter is suitable for three- and single phase applications. The handle is lockable to protect against unauthorized changes. Auxiliary contacts, signaling contacts, undervoltage releases, shunt trips, power in-feed blocks are available as accessory. These are suitable throughout the MS116/MS132/MS165-range.

Rated operational power						Setting range	Short-circuit current rating at 600 V AC	Rated instantaneous short-circuit current setting I <sub>l</sub>	Type	Weight (1 pce)
1-phase		3-phases				A	kA	A		kg
110-120 V	220-240 V	200-208 V	220-240 V	440-480 V	550-600 V					
hp	hp	hp	hp	hp	hp					
-	-	-	-	-	-	0.10 ... 0.16	47	2.00	MS132-0.16K	0.256
-	-	-	-	-	-	0.16 ... 0.25	47	3.10	MS132-0.25K	0.256
-	-	-	-	-	-	0.25 ... 0.40	47	5.00	MS132-0.4K	0.256
-	-	-	-	-	-	0.40 ... 0.63	47	7.90	MS132-0.63K	0.256
-	-	-	-	-	1/2	0.63 ... 1.00	47	12.5	MS132-1.0K	0.256
-	1/10	-	-	3/4	3/4	1.00 ... 1.60	47	20.0	MS132-1.6K	0.298
-	1/6	1/2	1/2	1	1.5	1.60 ... 2.50	47	31.3	MS132-2.5K	0.280
1/8	1/3	3/4	1	2	3	2.50 ... 4.00	47	50.0	MS132-4.0K	0.286
1/4	1/2	1	1.5	3	5	4.00 ... 6.30	18	78.8	MS132-6.3K	0.289
1/2	1.5	2	3	5	7.5	6.30 ... 10.0	18	150	MS132-10K	0.296
1	2	3	5	10	10	10.0 ... 16.0	18	240	MS132-16K	0.316
1.5	3	5	5	10	15	16.0 ... 20.0	18	300	MS132-20K	0.317
2	3	7.5 <sup>(1)</sup>	7.5	15	20	20.0 ... 25.0	18	375	MS132-25K	0.316
2	5	10	10	20	25	25.0 ... 32.0	18	480	MS132-32K	0.316

Note: Manual motor starters should always be selected so that the actual motor current is within the setting range.

(1) 5 hp at 200 V

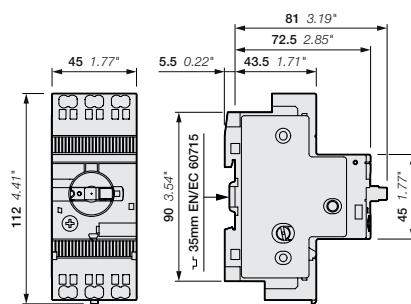

MS132-K > 10 A

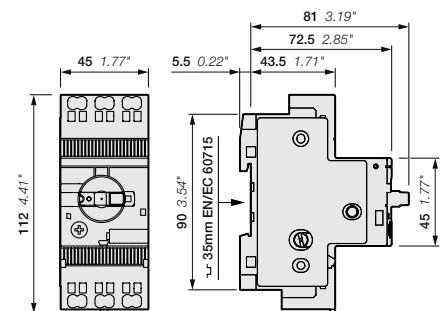

MS132-K ≤ 10 A

Main dimensions mm, inches

# MS132-K manual motor starters with Push-in Spring terminals

## Technical data

### Main circuit – Utilization characteristics according to IEC/EN

Type	MS132-K
Standards	IEC/EN 60947-1; IEC/EN 60947-2; IEC/EN 60947-4-1
Rated operational voltage $U_e$	690 V AC; 250 V DC
Rated frequency	DC, 50/60 Hz
Operating frequency	0 ... 400 Hz
Trip class	10
Number of poles	3
Duty time	100 %
Mechanical durability	100000 cycles
Electrical durability	50000 cycles
Rated impulse withstand voltage $U_{imp}$	6 kV
Rated insulation voltage $U_i$	690 V
Rated operational current $I_e$	See ordering details
Rated operational current DC-5 $I_e$ 3 conducting paths in series up to 250 V	See ordering details
Rated instantaneous short-circuit current setting $I_i$	See ordering details
Rated service short-circuit breaking capacity $I_{cs}$	See table "Short-circuit breaking capacity and back-up fuses"
Rated ultimate short-circuit breaking capacity $I_{cu}$	See table "Short-circuit breaking capacity and back-up fuses"
Rated service short-circuit breaking capacity DC $I_{cs}$ 3 conducting paths in series up to 250 V	10 kA

### Short-circuit breaking capacity and back-up fuses

$I_{cs}$  Rated service short-circuit breaking capacity  
 $I_{cu}$  Rated ultimate short-circuit breaking capacity  
 $I_q(I_{cc})$  Rated conditional short-circuit current

Type	230 V AC			400 V AC			440 V AC			500 V AC			690 V AC		
	$I_{cs}$ kA	$I_{cu}$ kA	gG, aM A	$I_{cs}$ kA	$I_{cu}$ kA	gG, aM A	$I_{cs}$ kA	$I_{cu}$ kA	gG, aM A	$I_{cs}$ kA	$I_{cu}$ kA	gG, aM A	$I_{cs}$ kA	$I_{cu}$ kA	gG, aM A
MS132-0.16K	100	100	-(1)	100	100	-(1)	100	100	-(1)	100	100	-(1)	100	100	-(1)
MS132-0.25K	100	100	-(1)	100	100	-(1)	100	100	-(1)	100	100	-(1)	100	100	-(1)
MS132-0.4K	100	100	-(1)	100	100	-(1)	100	100	-(1)	100	100	-(1)	100	100	-(1)
MS132-0.63K	100	100	-(1)	100	100	-(1)	100	100	-(1)	100	100	-(1)	100	100	-(1)
MS132-1.0K	100	100	-(1)	100	100	-(1)	100	100	-(1)	100	100	-(1)	100	100	-(1)
MS132-1.6K	100	100	-(1)	100	100	-(1)	100	100	-(1)	100	100	-(1)	100	100	-(1)
MS132-2.5K	100	100	-(1)	100	100	-(1)	100	100	-(1)	100	100	-(1)	100	100	-(1)
MS132-4.0K	100	100	-(1)	100	100	-(1)	30	30	35 (2)	20	20	35 (2)	3	3	32 (2)
MS132-6.3K	100	100	-(1)	100	100	-(1)	30	30	63 (2)	20	20	63 (2)	3	3	50 (2)
MS132-10K	100	100	-(1)	100	100	-(1)	30	30	100 (2)	20	20	100 (2)	3	3	50 (2)
MS132-16K	100	100	-(1)	100	100	-(1)	30	30	125 (2)	20	20	125 (2)	3	3	63 (2)
MS132-20K	100	100	-(1)	100	100	-(1)	30	30	125 (2)	20	20	125 (2)	3	3	80 (2)
MS132-25K	50	50	125 (2)	50	50	125 (2)	30	30	125 (2)	10	10	125 (2)	3	3	100 (2)
MS132-32K	30	50	125 (2)	30	50	125 (2)	30	30	125 (2)	10	10	125 (2)	3	3	100 (2)

(1) No back-up fuse required, because short-circuit proof up to  $I_{cu}$   
 (2) Maximum rated current of the back-up fuse for short circuit up to 100 kA if  $I_{cc} > I_{cs}$

## MS132-K manual motor starters with Push-in Spring terminals

### Technical data

#### Main circuit – Utilization characteristics according to UL/CSA

Type	MS132-K	
Standards	UL 60947-1, UL 60947-4-1 (UL 508), CSA C22.2 No.60947-4-1 (CSA C22.2 No.14)	
Rated operational voltage U <sub>e</sub> acc. to UL/CSA	600 V AC	
Trip class	10	
Motor ratings (1)	Horsepower	See table "Motor ratings, three phase"
	Full Load Amps (FLA)	See table "Motor ratings, three phase"
	Locked Rotor Amps (LRA)	See table "Motor ratings, three phase"

(1) See product data sheets for UL/CSA single phase motor and general use (AC-1) ratings.

#### UL/CSA ratings overview

Type	MS132-K
Manual Motor Controller	x
Manual Motor Controller, Suitable as Motor Disconnect	x
Manual Motor Controller, Suitable for use in Group Installations	x
Manual Motor Controller, Suitable for Tap Conductor Protection in Group Installations	x
Manual self-protected Combination Motor Controller (Type E)	x
Combination Motor Controller (Type F)	x

#### UL/CSA Motor ratings, three phase – MS132-K

Type	200 V AC			208 V AC			220 ... 240 V AC			440 ... 480 V AC			550 ... 600 V AC		
	hp	FLA	LRA	hp	FLA	LRA	hp	FLA	LRA	hp	FLA	LRA	hp	FLA	LRA
MS132-0.16K	-	0.16	0.96	-	0.16	0.96	-	0.16	0.96	-	0.16	0.96	-	0.16	0.96
MS132-0.25K	-	0.25	1.5	-	0.25	1.5	-	0.25	1.5	-	0.25	1.5	-	0.25	1.5
MS132-0.40K	-	0.4	2.4	-	0.4	2.4	-	0.4	2.4	-	0.4	2.4	-	0.4	2.4
MS132-0.63K	-	0.63	3.78	-	0.63	3.78	-	0.63	3.78	-	0.63	3.78	-	0.63	3.78
MS132-1.0K	-	1	6	-	1	6	-	1	6	-	1	6	1/2	1	6
MS132-1.6K	-	1.6	9.6	-	1.6	9.6	-	1.6	9.6	3/4	1.6	9.6	3/4	1.6	9.6
MS132-2.5K	1/2	2.5	15	1/2	2.5	15	1/2	2.5	15	1	2.5	15	1-1/2	2.5	15
MS132-4.0K	3/4	4	24	3/4	4	24	1	4	24	2	4	24	3	3.9	25.6
MS132-6.3K	1	6.3	37.8	1	6.3	37.8	1 1/2	6.3	37.8	3	4.8	32	5	6.1	36.8
MS132-10K	2	7.8	57.5	2	7.5	55	3	9.6	64	5	7.6	46	7 1/2	9	50.8
MS132-16K	3	11	73.6	3	10.6	71	5	15.2	92	10	14	81	10	11	64.8
MS132-20K	5	17.5	105.8	5	16.7	102	5	15.2	92	10	14	81	15	17	93
MS132-25K	5	17.5	105.8	7 1/2	24.2	140	7 1/2	22	127	15	21	116	20	22	116
MS132-32K	7 1/2	25.3	146	10	30.8	179	10	28	162	20	27	145	25	27	146

**UL/CSA Maximum short-circuit current ratings – MS132-K**

Type	Manual Motor Controllers Branch circuit protection, max. size per NEC/CEC (1)		for motor disconnect		for group installations		for tap conductor protection in group installations		Manual self- protected Combination Motor Controller (Type E) <sup>1)</sup>	
	Fuses	Circuit breaker	480 V	600 V	480 V	600 V	480Y / 277 V	600Y / 347 V	480Y / 277 V	600Y / 347 V
	A	A	kA	kA	kA	kA	kA	kA	kA	kA
MS132-0.16K	Any Listed fuses. Size per NEC/CEC	Any Listed UL489 / CSA C22.2 No.5 circuit breaker. Size per NEC/CEC	65	47	65	47	65	47	65	47
MS132-0.25K			65	47	65	47	65	47	65	47
MS132-0.40K			65	47	65	47	65	47	65	47
MS132-0.63K			65	47	65	47	65	47	65	47
MS132-1.0K			65	47	65	47	65	47	65	47
MS132-1.6K			65	47	65	47	65	47	65	47
MS132-2.5K			65	47	65	47	65	47	65	47
MS132-4.0K			65	47	65	47	65	47	65	47
MS132-6.3K			65	18	65	35	65	18	65	18
MS132-10K			65	18	65	35	65	18	65	18
MS132-16K			30	18	35	35	30	18	30	-
MS132-20K			30	18	35	35	30	18	30	-
MS132-25K			30	18	35	35	30	18	30	-
MS132-32K			30	18	35	35	30	18	30	-

**Combination Motor Controller Type F<sup>1)</sup>**

Type 2 Coordination

Type	480Y / 277 V kA	Contactor	600Y / 347 V kA	Contactor
MS132-0.16K	65	AF26 ... AF38	47	AF26 ... AF38
MS132-0.25K	65	AF26 ... AF38	47	AF26 ... AF38
MS132-0.40K	65	AF26 ... AF38	47	AF26 ... AF38
MS132-0.63K	65	AF26 ... AF38	47	AF26 ... AF38
MS132-1.0K	65	AF26 ... AF38	47	AF26 ... AF38
MS132-1.6K	65	AF26 ... AF38	47	AF26 ... AF38
MS132-2.5K	65	AF26 ... AF38	47	AF26 ... AF38
MS132-4.0K	65	AF26 ... AF38	47	AF26 ... AF38
MS132-6.3K	65	AF26 ... AF38	47	AF26 ... AF38
MS132-10K	65	AF26 ... AF38	47	AF26 ... AF38
MS132-16K	30	AF26 ... AF38	-	-
MS132-20K	30	AF26 ... AF38	-	-
MS132-25K	30	AF26 ... AF38	-	-
MS132-32K	30	AF26 ... AF38	-	-

**Combination Motor Controller Type F<sup>1)</sup>**

Type 1 Coordination

Type	480Y / 277 V kA	Contactor	600Y / 347 V kA	Contactor
MS132-0.16K	100	AF09 ... AF38	50	AF09 ... AF38
MS132-0.25K	100	AF09 ... AF38	50	AF09 ... AF38
MS132-0.40K	100	AF09 ... AF38	50	AF09 ... AF38
MS132-0.63K	100	AF09 ... AF38	50	AF09 ... AF38
MS132-1.0K	100	AF09 ... AF38	50	AF09 ... AF38
MS132-1.6K	100	AF09 ... AF38	50	AF09 ... AF38
MS132-2.5K	100	AF09 ... AF38	50	AF09 ... AF38
MS132-4.0K	100	AF09 ... AF38	50	AF09 ... AF38
MS132-6.3K	100	AF09 ... AF38	47	AF09 ... AF38
MS132-10K	100	AF09 ... AF38	30	AF09 ... AF38
MS132-16K	65	AF26 ... AF38	30	AF26 ... AF38
MS132-20K	65	AF26 ... AF38	-	-
MS132-25K	50	AF26 ... AF38	-	-
MS132-32K	50	AF38	-	-

<sup>1)</sup> MS132-K in combination with terminal spacer TS1-M3-K or PS1-xx-65K busbars

02  
15XPI0017-4C0202











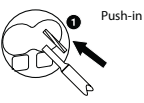









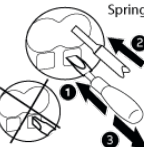



# MS132-K manual motor starters with Push-in Spring terminals

## Technical data

### General technical data

Type		MS132-K
Pollution degree		3
Phase loss sensitive		Yes
Disconnect function acc. to IEC/EN 60947-2		Yes
Ambient air temperature		
Operation	Open - compensated	-25 ... +60 °C
	Open	-25 ... +70 °C
	Enclosed (IB132)	0 ... +40 °C
Storage		-50 ... +80 °C
Ambient air temperature compensation		Acc. to IEC/EN60947-4-1
Maximum operating altitude permissible		2000 m
Resistance to shock acc. to IEC 60068-2-27		25g / 11 ms
Resistance to vibrations acc. to IEC 60068-2-6		5g / 3 ... 150 Hz
Mounting position		Position 1-6
Mounting on DIN rail		acc. to IEC 60715
Group mounting		On request
Minimum distance to other units same type	Horizontal	0 mm
	Vertical	150 mm
Minimum distance to electrical conductive board	Horizontal, up to 400 V	0 mm
	Horizontal, up to 690 V	> 1.5 mm
	Vertical	75 mm
Degree of protection	Housing	IP20
	Main circuit terminals	IP20

### Connecting characteristics - Main circuit

Manual motor starter type	MS132-K/MS132-KT	
 Push-in	 1 x  2 x	1 ... 6 mm <sup>2</sup> /AWG 10 ... 8
	 1 x  2 x	1 ... 2.5 mm <sup>2</sup>
	 1 x  2 x	1 ... 4 mm <sup>2</sup>
	 1 x  2 x	1 ... 4 mm <sup>2</sup> 1 ... 25 mm <sup>2</sup>
	 1 x  2 x	-
	 Spring	 1 x  2 x
 1 x  2 x		1 ... 2.5 mm <sup>2</sup>
 1 x  2 x		0.5 ... 4 mm <sup>2</sup>
 1 x  2 x		0.5 ... 4mm <sup>2</sup> 0.5 ... 2.5 mm <sup>2</sup>
 1 x  2 x		-
 1 x  2 x		∅ 3 mm x 0.5
 1 x  2 x		12 mm

## MS132-K

### Main accessories

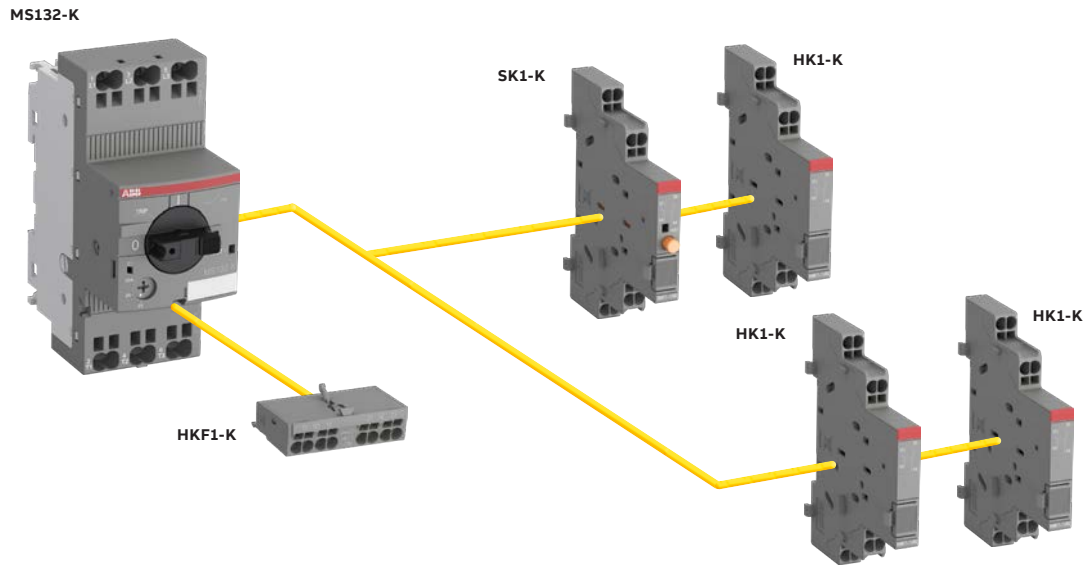

Note: SK1-K, HK1-K and HKF1-K are also suitable for manual motor starts with screw terminals.

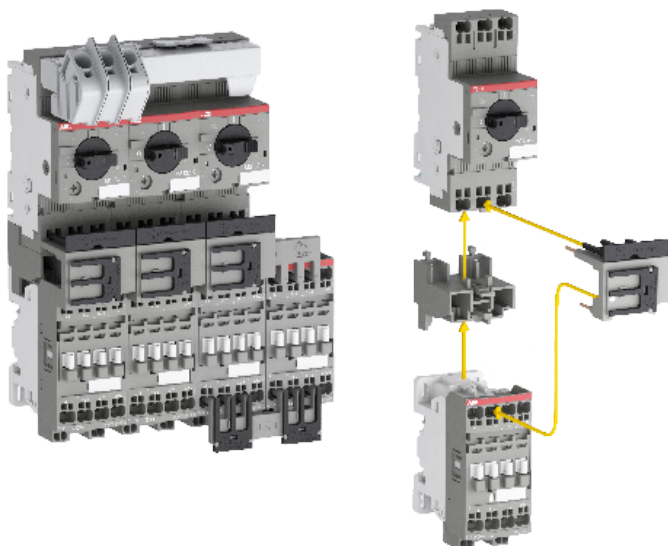

# MS132-K

## Main accessories with Push-in Spring terminals

MS132-K can be equipped with auxiliary contacts for lateral and front mounting as well as signaling contacts for lateral mounting. The accessories are equipped with Push-in Spring terminals that enable tool-free wiring. A variety of combinations is possible as required for the application. The auxiliary contacts change position with the main contacts. The signaling contact SK1 signals tripping regardless if it was caused by short-circuit or overload. These main accessories are suitable throughout the MS116/MS132/MS165-range.

### Auxiliary contacts

Suitable for	Auxiliary contacts NO	Auxiliary contacts NC	Description	Type	Order code	Pkg qty	Weight (1 pce) kg
--------------	-----------------------	-----------------------	-------------	------	------------	---------	-------------------

#### Mountable on the front

MS116, MS132, MS165	1	1		HKF1-11K	1SAM201901R1201	10	0.016
MO132, MO165, MS132-T, MS132-K	2	0		HKF1-20K	1SAM201901R1202	10	0.016

#### Mountable on the right

MS116, MS132, MS165	1	1		HK1-11K	1SAM201902R1201	2	0.035
MO132, MO165, MS132-T, MS132-K	2	0		HK1-20K	1SAM201902R1202	2	0.035
	0	2		HK1-02K	1SAM201902R1203	2	0.035
	2	0	with 2 leading contacts	HK1-20LK	1SAM201902R1204	2	0.035

### Signaling contacts - mountable on the right

Suitable for	Auxiliary contacts NO	Auxiliary contacts NC	Type	Order code	Pkg qty	Weight (1 pce) kg
MS116, MS132, MS165	1	1	SK1-11K	1SAM201903R1201	2	0.035
MO132, MO165, MS132-T, MS132-K	2	0	SK1-20K	1SAM201903R1202	2	0.035
	0	2	SK1-02K	1SAM201903R1203	2	0.035
	1	1	SK1-11ARK	1SAM201903R1204	2	0.035
	2	0	SK1-20ARK	1SAM201903R1205	2	0.035
	0	2	SK1-02ARK	1SAM201903R1206	2	0.035



2CDC24102YV0017

HKF1-11K



2CDC241028V0017

HK1-11K



2CDC241029V0017

SK1-11K



1SAM201903R1204

SK1-ARK

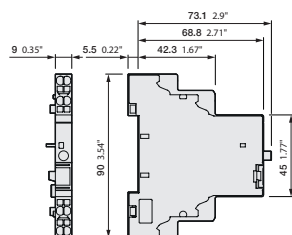

SK1-K

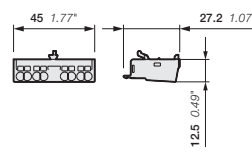

HKF1-K

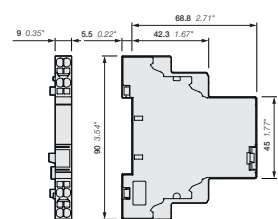

HK1-K, SK1-ARK

Main dimensions mm, inches

# MS132-K

## Technical data



### General technical data

Type	HK1-K, SK1-K		HKF1-K
Standards	IEC/EN 60947-1, IEC/EN 60947-5-1		
Rated operational voltage $U_e$	690 V AC, 600 V DC		250 V AC / 250 V DC
Conventional free-air thermal current $I_{th}$	6 A		5 A
Rated frequency	DC, 50/60 Hz		
Rated impulse withstand voltage $U_{imp}$	6 kV		
Rated insulation voltage $U_i$	690 V AC		250 V AC
Pollution degree	3		
Ambient air temperature	Operation	-25 ... +60 °C	
	Storage	-50 ... +80 °C	
Resistance to shock acc. to IEC 60068-2-27	25 g / 11 ms		
Resistance to vibrations acc. to IEC 60068-2-6	5 g / 3... 150 Hz		
I <sub>e</sub> / Rated operational current AC-15 acc. to IEC/EN 60947-5-1 for utilization category	24 V, 120 V	6 A	3 A
	240 V	4 A	1.5 A
	400 V	3 A	-
	690 V	1 A	-
I <sub>e</sub> / Rated operational current DC-13 acc. to IEC/EN 60947-5-1 for utilization category	24 V	2 A	1 A
	125 V	0.55 A	0.27 A
	250 V	0.27 A	0.11 A
	440 V, 600 V	0.15 A	-
Minimum switching capacity	17 V / 5 mA		
Short-circuit protective device	N.C., 95-96	10 A Type gG	
	N.O., 97-98	10 A Type gG	
Duty time	100 %		
Mounting	Right side of Manual Motor Starter/ MS132-K		Front of Manual Motor Starter / MS132-K
Mounting position	1 to 6		
Mechanical durability	100 000 cycles		-
Electrical durability	100 000 cycles		-

### Contact utilization characteristics according to UL/CSA

Type	HK1-K, SK1-K		HKF1-K
Standards	UL /CSA 60947-1, UL/CSA 60947-4-1 (UL 508), (CSA C22.2 No. 14)		
Rated operational voltage $U_e$ acc. to UL/CSA	600 V AC / 600 V DC		250 V AC / 250 V DC
Pilot duty	B600, Q600		B300, R300
AC thermal rated current	5 A		5 A
AC maximum volt-ampere making	7200 VA		3600 VA
AC maximum volt-ampere breaking	720 VA		360 VA
DC thermal rated current	2.5 A		2.5 A
DC maximum volt-ampere making-breaking	69 VA		69 VA

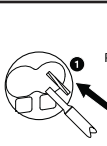
### Connecting characteristics - Auxiliary circuit

Type	HK1-K, SK1-K, HKF1-K	
 Push-in	1 or 2 x	1 ... 2.5 mm <sup>2</sup> /AWG 14
	1 or 2 x	1 ... 2.5 mm <sup>2</sup>
	1 or 2 x	1 ... 2.5 mm <sup>2</sup>
	1 or 2 x	1 ... 1.5 mm <sup>2</sup>
	1 or 2 x	-
 Spring	1 or 2 x	1 ... 2.5 mm <sup>2</sup> /AWG 20...14
	1 or 2 x	1 ... 2.5 mm <sup>2</sup>
	1 or 2 x	0.5 ... 2.5 mm <sup>2</sup>
	1 or 2 x	0.5 ... 2.5 mm <sup>2</sup>
	1 or 2 x	0.5 ... 1.5 mm <sup>2</sup>
	1 or 2 x	∅ 3 mm / x 0.5
	1 or 2 x	12 mm

# Accessories with Push-in Spring terminals

## MS132-K, MS132-KT

### Three-phase busbars with Push-in Spring terminals

Three-phase busbars ensure a quick and safe connection and are therefore a cost effective solution. Busbars with Push-in Spring terminals enable tool-free wiring and eliminate the need for routine re-tightening. Between 2 and 5 manual motor starters with none or one lateral auxiliary contact can be connected.



9PAA000008525

PS1-2-0-65K



9PAA0000085240

PS1-5-0-65K

Suitable for	Rated operational current	No. of manual motor starters	No. of lateral auxiliary contacts	Type	Order code	Pkg qty	Weight (1 pce)
	A						kg
MS132-K, MS132-KT	65	2	0	PS1-2-0-65K	1SAM301903R1002	1	0.089 kg
	65	3	0	PS1-3-0-65K	1SAM301903R1003	1	0.093 kg
	65	4	0	PS1-4-0-65K	1SAM301903R1004	1	0.114 kg
	65	5	0	PS1-5-0-65K	1SAM301903R1005	1	0.122 kg
	65	2	1	PS1-2-1-65K	1SAM301903R1012	1	0.139 kg
	65	3	1	PS1-3-1-65K	1SAM301903R1013	1	0.150 kg
	65	4	1	PS1-4-1-65K	1SAM301903R1014	1	0.163 kg
	65	5	1	PS1-5-1-65K	1SAM301903R1015	1	0.177 kg

### Terminal spacers, Type E/F



9PAA0000014829

TS1-M3-K

Suitable for	Description	Type	Order Code	Pkg qty	Weight (1 pce)
MS132-K, MS132-KT	UL/CSA Type E/F and IEC	TS1-M3-K	1SAM301913R1001	1	0.012 kg

### Additional accessories



9PAA0000085267

BS1-K

Suitable for	Description	Type	Order Code	Pkg qty	Weight (1 pce)
					kg
MS132-K, MS132-KT	Protection cover for PS1-K busbar	BS1-K	1SAM301904R1D01	1	0.002 kg
	Padlock + two keys	SA2	GJF1101903R0002	1	0.020 kg













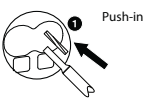









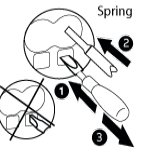

2CDC241023F0013

SA2

## General technical data

Type		PS1-xxx-65K
Standards		IEC/EN 60947-4-1, IEC/EN 60947-1, UL 60947-1, UL 60947-4-1 (UL 508), CSA C22.2 No.60947-4-1 (CSA C22.2 No.14)
Rated operational voltage Ue		690 V
Rated operational voltage Ue acc. to UL/CSA		600 V AC
Rated operational current Ie		65 A
Rated operational current Ie acc. to UL/CSA		65 A
Rated frequency		50/60 Hz
Rated impulse withstand voltage Uimp		6 kV
Rated insulation voltage Ui		690 V AC
Pollution degree		3
Ambient air temperature		Operation -25 ... +70 °C Storage -50 ... +80 °C
Resistance to shock acc. to IEC 60068-2-27		25g / 11 ms
Resistance to vibrations acc. to IEC 60068-2-6		5g / 3 ... 150 Hz

## Connecting characteristics- busbars

Type		PS1-xx-65K	
 Push-in		1 x	6 ... 25 mm <sup>2</sup> /AWG 8 ... 4
		2 x	-
		1 x	4 ... 16 mm <sup>2</sup>
		2 x	-
		1 x	4 ... 16 mm <sup>2</sup>
		2 x	-
		1 x	4 ... 16 mm <sup>2</sup>
		2 x	-
		1 x	4 ... 6 mm <sup>2</sup>
		2 x	-
 Spring		1 x	1.5 ... 2.5 mm <sup>2</sup> /AWG 18...4
		2 x	-
		1 x	0.5 ... 16 mm <sup>2</sup>
		2 x	-
		1 x	0.5 ... 16 mm <sup>2</sup>
		2 x	-
		1 x	0.5 ... 6 mm <sup>2</sup>
		2 x	-
		1 x	Ø 4 mm
		2 x	x 0.5
	1 x	16 mm	
	2 x	-	



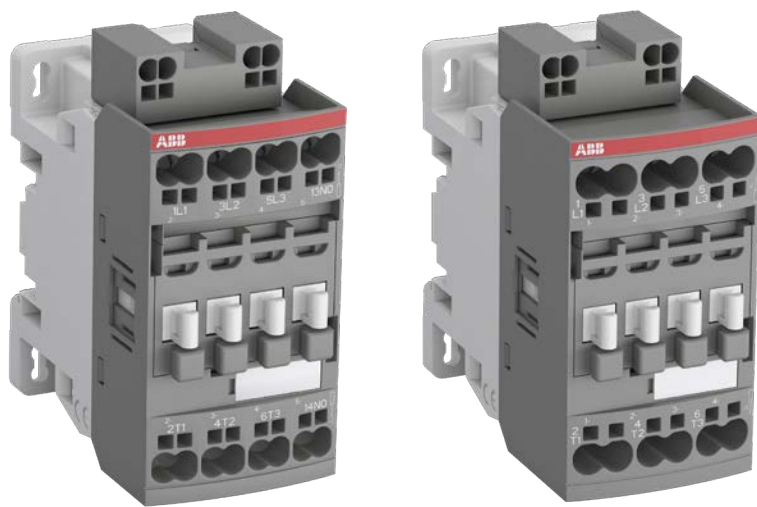

---

# 3-pole contactors

## Ordering details

### 7.5 to 30 hp

- 27 AF09..K ... AF38..K - AC / DC operated
- 28 AF09Z..K ... AF38Z..K 24 V DC - designed for PLC
- 29 AF09Z..K ... AF38Z..K - AC / DC operated  
for specific applications

## 36 Main accessories

## 39 Technical data

## 41 Electrical durability

## 45 Terminal marking and positioning

## 47 Dimensions

# AF09..K ... AF38..K 3-pole contactors - with Push-in Spring terminals

7.5 to 30 hp

AC / DC operated



AF09-30-10K



AF26-30-00K

AF09..K ... AF38..K contactors are mainly used for controlling 3-phase motors and power circuits up to 600 V AC and 250 V DC. These contactors are of the block type design with 3 main poles.

- control circuit: AC or DC operated with electronic coil interface accepting a wide control voltage range (e.g. 100...250 V AC and DC), only 4 control voltage ranges covering 24...500 V 50/60 Hz and 20...500 V DC
  - can manage large control voltage variations
  - reduced panel energy consumption
  - very distinct closing and opening
- built-in surge suppression
- add-on auxiliary contact blocks for front or side mounting and a wide range of accessories.

UL/CSA							Rated control circuit voltage		Auxiliary contacts fitted	Type (1)	Weight Pkg (1 pce)
General use rating	1-phase		3-phases				Uc min. ... Uc max.				
600 V AC	110-120 V	220-240 V	200-208 V	220-240 V	440-480 V	550-600 V	V 50/60 Hz	V DC		kg	
A	hp	hp	hp	hp	hp	hp	24 ... 60	20 ... 60	1 0	AF09-30-10K-11	0.285
									0 1	AF09-30-01K-11	0.285
									1 0	AF09-30-10K-12	0.285
									0 1	AF09-30-01K-12	0.285
									1 0	AF09-30-10K-13	0.285
									0 1	AF09-30-01K-13	0.285
									1 0	AF09-30-10K-14	0.325
									0 1	AF09-30-01K-14	0.325
									1 0	AF12-30-10K-11	0.285
									0 1	AF12-30-01K-11	0.285
									1 0	AF12-30-10K-12	0.285
									0 1	AF12-30-01K-12	0.285
1 0	AF12-30-10K-13	0.285									
0 1	AF12-30-01K-13	0.285									
1 0	AF12-30-10K-14	0.325									
0 1	AF12-30-01K-14	0.325									
25	3/4	1.5	2	2	5	7.5	24 ... 60	20 ... 60	1 0	AF16-30-10K-11	0.285
									0 1	AF16-30-01K-11	0.285
									1 0	AF16-30-10K-12	0.285
									0 1	AF16-30-01K-12	0.285
									1 0	AF16-30-10K-13	0.285
									0 1	AF16-30-01K-13	0.285
									1 0	AF16-30-10K-14	0.325
									0 1	AF16-30-01K-14	0.325
									1 0	AF16-30-10K-11	0.285
									0 1	AF16-30-01K-11	0.285
									1 0	AF16-30-10K-12	0.285
									0 1	AF16-30-01K-12	0.285
1 0	AF16-30-10K-13	0.285									
0 1	AF16-30-01K-13	0.285									
1 0	AF16-30-10K-14	0.325									
0 1	AF16-30-01K-14	0.325									
28	1	2	3	3	7.5	10	24 ... 60	20 ... 60	1 0	AF16-30-10K-11	0.285
									0 1	AF16-30-01K-11	0.285
									1 0	AF16-30-10K-12	0.285
									0 1	AF16-30-01K-12	0.285
									1 0	AF16-30-10K-13	0.285
									0 1	AF16-30-01K-13	0.285
									1 0	AF16-30-10K-14	0.325
									0 1	AF16-30-01K-14	0.325
									1 0	AF16-30-10K-11	0.285
									0 1	AF16-30-01K-11	0.285
									1 0	AF16-30-10K-12	0.285
									0 1	AF16-30-01K-12	0.285
1 0	AF16-30-10K-13	0.285									
0 1	AF16-30-01K-13	0.285									
1 0	AF16-30-10K-14	0.325									
0 1	AF16-30-01K-14	0.325									
30	1.5	3	5	5	10	15	24 ... 60	20 ... 60	1 0	AF26-30-00K-11	0.325
									0 0	AF26-30-00K-11	0.325
									1 0	AF26-30-00K-12	0.325
									0 0	AF26-30-00K-12	0.325
									1 0	AF26-30-00K-13	0.325
									0 0	AF26-30-00K-13	0.325
									1 0	AF26-30-00K-14	0.365
									0 0	AF26-30-00K-14	0.365
									1 0	AF30-30-00K-11	0.330
									0 0	AF30-30-00K-11	0.330
									1 0	AF30-30-00K-12	0.330
									0 0	AF30-30-00K-12	0.330
1 0	AF30-30-00K-13	0.330									
0 0	AF30-30-00K-13	0.330									
1 0	AF30-30-00K-14	0.370									
0 0	AF30-30-00K-14	0.370									
42	2	3	7.5	7.5	15	20	24 ... 60	20 ... 60	1 0	AF38-30-00K-11	0.330
									0 0	AF38-30-00K-11	0.330
									1 0	AF38-30-00K-12	0.330
									0 0	AF38-30-00K-12	0.330
									1 0	AF38-30-00K-13	0.330
									0 0	AF38-30-00K-13	0.330
									1 0	AF38-30-00K-14	0.370
									0 0	AF38-30-00K-14	0.370
									1 0	AF38-30-00K-11	0.330
									0 0	AF38-30-00K-11	0.330
									1 0	AF38-30-00K-12	0.330
									0 0	AF38-30-00K-12	0.330
1 0	AF38-30-00K-13	0.330									
0 0	AF38-30-00K-13	0.330									
1 0	AF38-30-00K-14	0.370									
0 0	AF38-30-00K-14	0.370									
45	2	5	10	10	20	25	24 ... 60	20 ... 60	1 0	AF38-30-00K-11	0.330
									0 0	AF38-30-00K-11	0.330
									1 0	AF38-30-00K-12	0.330
									0 0	AF38-30-00K-12	0.330
									1 0	AF38-30-00K-13	0.330
									0 0	AF38-30-00K-13	0.330
									1 0	AF38-30-00K-14	0.370
									0 0	AF38-30-00K-14	0.370
									1 0	AF38-30-00K-11	0.330
									0 0	AF38-30-00K-11	0.330
									1 0	AF38-30-00K-12	0.330
									0 0	AF38-30-00K-12	0.330
1 0	AF38-30-00K-13	0.330									
0 0	AF38-30-00K-13	0.330									
1 0	AF38-30-00K-14	0.370									
0 0	AF38-30-00K-14	0.370									

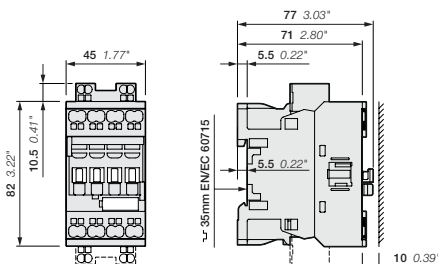

AF09..K, AF12..K, AF16..K

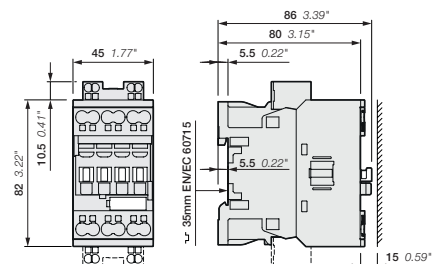

AF26..K, AF30..K, AF38..K

Main dimensions mm, inches

# AF09Z..K ... AF38Z..K 3-pole contactors - with Push-in Spring terminals

7.5 to 30 hp

AC / DC operated - for specific applications



AF09Z-30-10K



AF26Z-30-00K

AF09Z..K ... AF38Z..K contactors are mainly used for controlling 3-phase motors and power circuits up to 600 V AC and 250 V DC. These contactors are of the block type design with 3 main poles.

- control circuit: AC or DC operated with electronic coil interface accepting a wide control voltage range (e.g. 100...250 V AC and DC), only 4 control voltage ranges covering 24...250 V 50/60 Hz and 12...250 V DC
  - can manage large control voltage variations
  - allow direct control by PLC-output  $\geq 24$  V DC 500 mA (1)
  - reduced panel energy consumption
  - very distinct closing and opening
  - can withstand short voltage dips and voltage sags (SEMI F47-0706 conditions of use on request)
- built-in surge suppression
- add-on auxiliary contact blocks for front or side mounting and a wide range of accessories.

UL/CSA							Rated control circuit voltage		Auxiliary contacts fitted	Type	Weight
General use rating	1-phase		3-phases				Uc min. ... Uc max.				
600 V AC	110-120 V	220-240 V	200-208 V	220-240 V	440-480 V	550-600 V	V 50/60 Hz	V DC		kg	
A	hp	hp	hp	hp	hp	hp	-	12 ... 20	1 0	AF09Z-30-10K-20	0.315
									0 1	AF09Z-30-01K-20	0.315
									1 0	AF09Z-30-10K-21	0.315
									0 1	AF09Z-30-01K-21	0.315
									1 0	AF09Z-30-10K-22	0.315
									0 1	AF09Z-30-01K-22	0.315
									1 0	AF09Z-30-10K-23	0.315
									0 1	AF09Z-30-01K-23	0.315
									1 0	AF12Z-30-10K-20	0.315
									0 1	AF12Z-30-01K-20	0.315
									1 0	AF12Z-30-10K-21	0.315
									0 1	AF12Z-30-01K-21	0.315
1 0	AF12Z-30-10K-22	0.315									
0 1	AF12Z-30-01K-22	0.315									
1 0	AF12Z-30-10K-23	0.315									
0 1	AF12Z-30-01K-23	0.315									
25	3/4	1.5	2	2	5	7.5	-	12 ... 20	1 0	AF16Z-30-10K-20	0.315
									0 1	AF16Z-30-01K-20	0.315
									1 0	AF16Z-30-10K-21	0.315
									0 1	AF16Z-30-01K-21	0.315
									1 0	AF16Z-30-10K-22	0.315
									0 1	AF16Z-30-01K-22	0.315
									1 0	AF16Z-30-10K-23	0.315
									0 1	AF16Z-30-01K-23	0.315
									1 0	AF26Z-30-00K-20	0.355
									0 0	AF26Z-30-00K-21	0.355
									0 0	AF26Z-30-00K-22	0.355
									0 0	AF26Z-30-00K-23	0.355
28	1	2	3	3	7.5	10	-	12 ... 20	1 0	AF30Z-30-00K-20	0.360
									0 0	AF30Z-30-00K-21	0.360
									0 0	AF30Z-30-00K-22	0.360
									0 0	AF30Z-30-00K-23	0.360
									1 0	AF38Z-30-00K-20	0.360
									0 0	AF38Z-30-00K-21	0.360
									0 0	AF38Z-30-00K-22	0.360
									0 0	AF38Z-30-00K-23	0.360
									1 0	AF30Z-30-00K-20	0.360
									0 0	AF30Z-30-00K-21	0.360
									0 0	AF30Z-30-00K-22	0.360
									0 0	AF30Z-30-00K-23	0.360
30	1.5	3	5	5	10	15	-	12 ... 20	1 0	AF30Z-30-00K-20	0.360
									0 0	AF30Z-30-00K-21	0.360
									0 0	AF30Z-30-00K-22	0.360
									0 0	AF30Z-30-00K-23	0.360
									1 0	AF38Z-30-00K-20	0.360
									0 0	AF38Z-30-00K-21	0.360
									0 0	AF38Z-30-00K-22	0.360
									0 0	AF38Z-30-00K-23	0.360
									1 0	AF30Z-30-00K-20	0.360
									0 0	AF30Z-30-00K-21	0.360
									0 0	AF30Z-30-00K-22	0.360
									0 0	AF30Z-30-00K-23	0.360
42	2	3	7.5	7.5	15	20	-	12 ... 20	0 0	AF30Z-30-00K-20	0.360
									0 0	AF30Z-30-00K-21	0.360
									0 0	AF30Z-30-00K-22	0.360
									0 0	AF30Z-30-00K-23	0.360
									1 0	AF38Z-30-00K-20	0.360
									0 0	AF38Z-30-00K-21	0.360
									0 0	AF38Z-30-00K-22	0.360
									0 0	AF38Z-30-00K-23	0.360
									1 0	AF30Z-30-00K-20	0.360
									0 0	AF30Z-30-00K-21	0.360
									0 0	AF30Z-30-00K-22	0.360
									0 0	AF30Z-30-00K-23	0.360
45	2	5	10	10	20	25	-	12 ... 20	0 0	AF30Z-30-00K-20	0.360
									0 0	AF30Z-30-00K-21	0.360
									0 0	AF30Z-30-00K-22	0.360
									0 0	AF30Z-30-00K-23	0.360
									1 0	AF38Z-30-00K-20	0.360
									0 0	AF38Z-30-00K-21	0.360
									0 0	AF38Z-30-00K-22	0.360
									0 0	AF38Z-30-00K-23	0.360
									1 0	AF30Z-30-00K-20	0.360
									0 0	AF30Z-30-00K-21	0.360
									0 0	AF30Z-30-00K-22	0.360
									0 0	AF30Z-30-00K-23	0.360

(1) For control by safety PLCs using broken wire detection, please contact your ABB local sales organization.  
 Note: Only AF..Z contactors with DC control voltage 12...20 V DC need to respect the connection polarities indicated close to the coil terminals: A1+ for the positive pole and A2- for the negative pole.

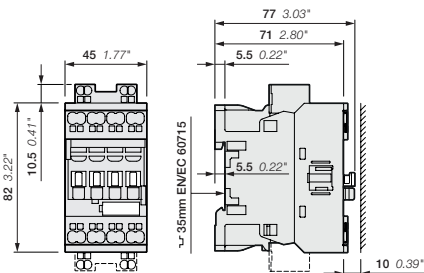

AF09Z..K, AF12Z..K, AF16Z..K

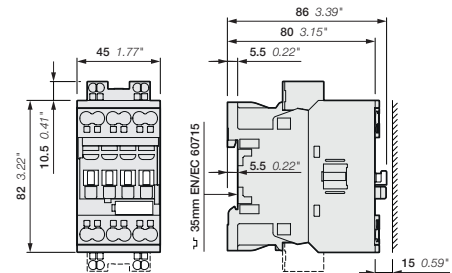

AF26Z..K, AF30Z..K, AF38Z..K

Main dimensions mm, inches

# AF09Z..K ... AF38Z..K 3-pole contactors - with Push-in Spring terminals

7.5 to 30 hp

24 V DC operated - designed for PLC



AF09Z-30-10K

15BC101597V0014



AF26Z-30-00K

15BC101599V0014

AF09Z..K ... AF38Z..K contactors are mainly used for controlling 3-phase motors and power circuits up to 600 V AC and 250 V DC. These contactors are of the block type design with 3 main poles.

- control circuit: DC operated with electronic coil interface allowing low holding consumption up to 1.7 W and reduced panel energy consumption
  - allow direct control by PLC-output  $\geq 250$  mA 24 V DC
  - very distinct closing and opening built-in surge suppression
- add-on auxiliary contact blocks for front or side mounting and a wide range of accessories.

UL/CSA							Rated control circuit voltage		Auxiliary contacts fitted	Type	Weight Pkg (1 pce) kg
General use rating 600 V AC	1-phase		3-phases				Uc min. ... Uc max.				
	110-120 V	220-240 V	200-208 V	220-240 V	440-480 V	550-600 V	V 50/60 Hz	V DC			
25	3/4	1.5	2	2	5	7.5	-	24	1 0	AF09Z-30-10K-30	0.435
									0 1	AF09Z-30-01K-30	0.435
28	1	2	3	3	7.5	10	-	24	1 0	AF12Z-30-10K-30	0.435
									0 1	AF12Z-30-01K-30	0.435
30	1.5	3	5	5	10	15	-	24	1 0	AF16Z-30-10K-30	0.435
									0 1	AF16Z-30-01K-30	0.435
42	2	3	7.5	7.5	15	20	-	24	0 0	AF26Z-30-00K-30	0.440
45	2	5	10	10	20	25	-	24	0 0	AF30Z-30-00K-30	0.440
45	2	5	10	10	25	30	-	24	0 0	AF38Z-30-00K-30	0.440

(1) Note: AF..Z contactors with 24V DC control voltage need to respect the connection polarities indicated close to the coil terminals: A1+ for the positive pole and A2- for the negative pole.

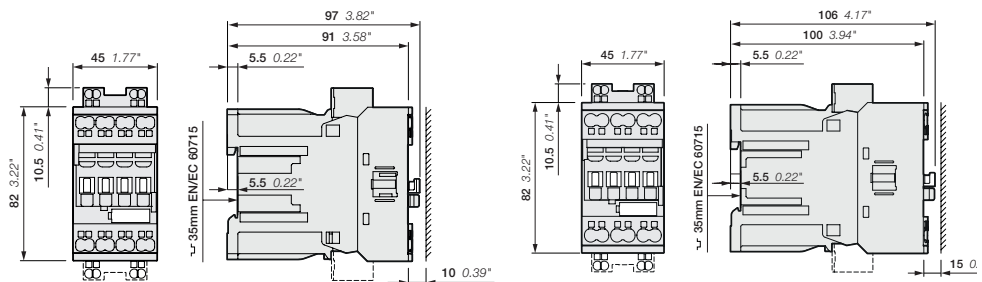

AF09Z..K, AF12Z..K, AF16Z..K

AF26Z..K, AF30Z..K, AF38Z..K

Main dimensions mm, inches

# AF09..K ... AF16..K 3-pole contactors - with Push-in Spring terminals

## Main accessories

### Contactor and main accessories (other accessories available)

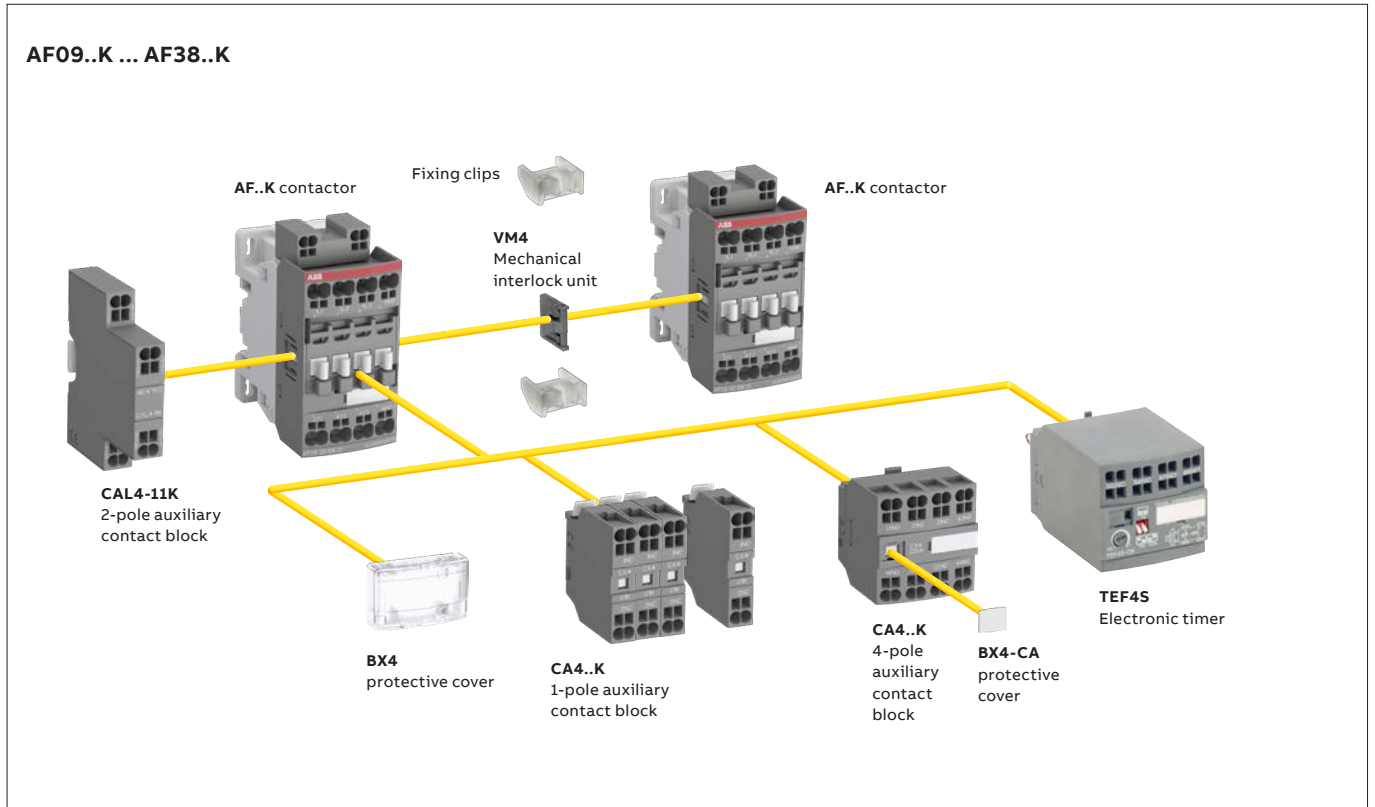

### Main accessory fitting details - for ordering details, technical data and other accessories: see section accessories

Many configurations of accessories are possible depending on whether these are front-mounted or side-mounted.

Contactor types	Main poles	Built-in auxiliary contacts	Front-mounted accessories			Side-mounted accessories		
			Auxiliary contact blocks		Electronic timer	Mechanical interlock unit (between 2 contactors)	Auxiliary contact blocks	
			1-pole CA4..K	4-pole CA4..K	TEF4S	VM4	Left side	Right side
<b>AF09(Z)..K ... AF38(Z)..K (1)</b>								
AF09..K ... AF16..K	3 0	0 1	4 max.	or 1	or 1	-	+ 1	-
AF09..K ... AF16..K	3 0	1 0	2 max.	-	or 1	-	+ 1	+ 1
AF26..K ... AF38..K	3 0	0 0	4 max.	or 1	or 1	+ 1	+ 1	or 1
<b>AF09Z..K ... AF38Z..K 24 V DC designed for PLC - coil 30 (1)</b>								
AF09Z..K ... AF16Z..K	3 0	0 1	4 max.	or 1	or 1	+ 1	+ 1	+ 1
AF09Z..K ... AF16Z..K	3 0	1 0	2 max.	-	or 1	+ 1	+ 1	or 1
AF26Z..K ... AF38Z..K	3 0	0 0			1	-	+ 1	+ 1

(1) Including add-on and built-in contacts: 4 N.C. auxiliary contacts max. on positions 1, 2, 3, 4 and 3 N.C. auxiliary contacts max. on positions 1 ±30°, 5

# AF09..K ... AF38..K 3-pole contactors - with Push-in Spring terminals

## Main accessories



CA4-10K

1SBCL00080V0014

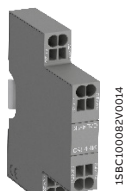

CAL4-11K

1SBCL00082V0014



CA4-22EK

1SBCL00081V0014



VM4

1SBCL00010V0014



TEF4S-ON

1SBCL01394F0014



LDC4K

1SBCL00090V0014



BX4

1SBCL00021V0014

For contactors	Auxiliary contacts	Type	Order code	Pkg qty	Weight (1 pce)
					kg

### Front-mounted instantaneous auxiliary contact blocks

For contactors	Auxiliary contacts	Type	Order code	Pkg qty	Weight (1 pce)
AF09..K ... AF38..K	1 0	CA4-10K	1SBN010160R1010	1	0.012
	1 0	CA4-10K-T	1SBN010160T1010	10	0.012
	0 1	CA4-01K	1SBN010160R1001	1	0.012
	0 1	CA4-01K-T	1SBN010160T1001	10	0.012
AF26 ... AF16...-40-00K	2 2	CA4-22MK	1SBN010146R1122	1	0.050
AF26 ... AF38...-40-00K	2 2	CA4-22EK	1SBN010146R1022	1	0.050

### Side-mounted instantaneous auxiliary contact blocks

For contactors	Auxiliary contacts	Type	Order code	Pkg qty	Weight (1 pce)
AF09..K ... AF38..K	1 1	CAL4-11K	1SBN010134R1011	1	0.030

### Mechanical interlock unit

For contactors	Type	Order code	Pkg qty	Weight (1 pce)
AF09..K ... AF38..K	VM4	1SBN030105T1000	10	0.005

Note: VM4 includes 2 fixing clips (BB4) to maintain together both contactors.

### Fixing clips

For contactors	Type	Order code	Pkg qty	Weight (1 pce)
AF09..K ... AF16..K	BB4	1SBN110120W1000	50	0.002

### Electronic timers

For contactors	Time delay range selected by switch	Delay type	Auxiliary contacts	Type	Order code	Pkg qty	Weight (1 pce)
AF09..K ...	0.1...1 s	ON-delay	1 1	TEF4S-ON	1SBN020113R1000	1	0.065
AF38..K	1...10 s	OFF-delay	1 1	TEF4S-OFF	1SBN020115R1000	1	0.065
	10...100 s						

Note: Rated control circuit voltage Uc 24 ... 240 V 50/60 Hz or DC. Terminals with spring mode only.

### Additional coil terminal block

For contactors	Type	Order code	Pkg qty	Weight (1 pce)
AF09..K ... AF38..K, NF	LDC4K	1SBN070159T1000	10	0.010

### Protective covers

For contactors	Type	Order code	Pkg qty	Weight (1 pce)
AF09..K ... AF38..K 1-stack contactors and NF contactor relays	BX4	1SBN110108T1000	10	0.006
4-pole CA4 auxiliary contact blocks and TEF4 electronic timer	BX4-CA	1SBN110109W1000	50	0.001

Note: CA4..K and CAL4-11K contact blocks can be used on AF09...AF96 contactors.

# Connection accessories for starting solutions- with Push-in Spring terminals

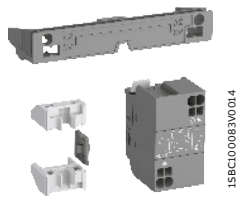

1SBCL00083030004

VEM4K

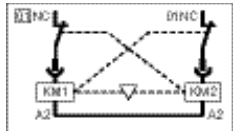

For contactors	Auxiliary contacts	Type	Order code	Pkg qty	Weight (1 pce)
					kg
<b>Mechanical and electrical interlock set (1)</b>					
AF09..K ... AF16..K	0 2	VEM4K	1SBN030113R1000	1	0.030
AF26..K ... AF38..K					

Note: - VEM4K includes a VM4 mechanical interlock unit with 2 fixing clips (BB4), a VE4K electrical interlock block with A2 - A2 connection.  
 - VE4K block must be used with A2-A2 connection to respect the electrical connection diagram.  
 - VEM4K not suitable for AF..Z contactors with DC control voltage 12 ... 20 V DC (coil 20 and 24 V DC (coil 30)).  
 For product availability, please consult your ABB local sales organization.



1SBCL016730004

BEA16-4KF

### Connecting links with manual motor starters (1)

AF09..K ... AF16..K	with MS132-0.16K... MS132-25K	BEA16-4KF	1SBN081325T1000	10	0.052
AF26..K ... AF38..K	with MS132-0.16K... MS132-32K	BEA38-4KF	1SBN082325T2000	10	0.057

(1) For product availability, please consult your ABB local sales organization.  
 Note: BEA not suitable for AF..Z contactors with DC control voltage 24 V DC (coil 30).



1SBCL001280004

BER16-4KF

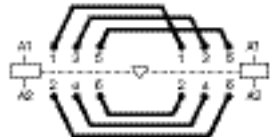

BER  
Reversing connections

### Connection sets for reversing contactors

AF09..K ... AF16..K	BER16-4KF	1SBN081322R1000	1	0.050
AF26..K ... AF38..K	BER38-4KF	1SBN082322R1000	1	0.080

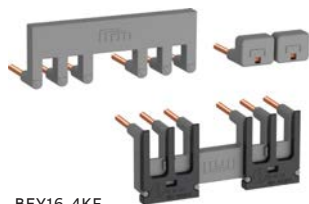

1SBCL001290004

BEY16-4KF



BEY  
Line-delta-star connection

### Connection sets for star-delta starter

AF09..K ... AF16..K	BEY16-4KF	1SBN081323R2000	1	0.055
AF26..K ... AF38..K	BEY38-4KF	1SBN082323R2000	1	0.090

# AF09..K ... AF38..K 3-pole contactors - with Push-in Spring terminals

## Technical data

### Main pole - Utilization characteristics according to IEC

Contactor types	AC / DC operated	AF09..K	AF12..K	AF16..K	AF26..K	AF30..K	AF38..K
Standards		IEC 60947-1 / 60947-4-1 and EN 60947-1 / 60947-4-1					
Rated operational voltage Ue max.		690 V					
Rated frequency (without derating)		50 / 60 Hz					
Conventional free-air thermal current Ith acc. to IEC 60947-4-1, open contactors, $\theta \leq 40^\circ\text{C}$		35 A	35 A	35 A	50 A	50 A	50 A
With conductor cross-sectional area		6 mm <sup>2</sup>	6 mm <sup>2</sup>	6 mm <sup>2</sup>	10 mm <sup>2</sup>	10 mm <sup>2</sup>	10 mm <sup>2</sup>
AC-1 Utilization category							
For air temperature close to contactor							
le / Rated operational current AC-1	$\theta \leq 40^\circ\text{C}$	25 A	28 A	30 A	45 A	50 A	50 A
Ue max. $\leq 690\text{ V}, 50/60\text{ Hz}$	$\theta \leq 60^\circ\text{C}$	25 A	28 A	30 A	40 A	42 A	42 A
	$\theta \leq 70^\circ\text{C}$	22 A	24 A	26 A	32 A	37 A	37 A
With conductor cross-sectional area		4 mm <sup>2</sup>	6 mm <sup>2</sup>	6 mm <sup>2</sup>	10 mm <sup>2</sup>	10 mm <sup>2</sup>	10 mm <sup>2</sup>
AC-3, AC-3e Utilization category							
For air temperature close to contactor $\theta \leq 60^\circ\text{C}$							
le / Max. rated operational current AC-3, AC-3e (1)							
	220-230-240 V	9 A	12 A	18 A	26 A	33 A	40 A
	380-400 V	9 A	12 A	18 A	26 A	32 A	38 A
	415 V	9 A	12 A	18 A	26 A	32 A	38 A
	440 V	9 A	12 A	18 A	26 A	32 A	38 A
	500 V	9.5 A	12.5 A	15 A	23 A	28 A	33 A
	690 V	7 A	9 A	10.5 A	17 A	21 A	24 A
	1000 V	-	-	-	-	-	-
Rated operational power AC-3, AC-3e (1)							
	220-230-240 V	2.2 kW	3 kW	4 kW	6.5 kW	9 kW	11 kW
	380-400 V	4 kW	5.5 kW	7.5 kW	11 kW	15 kW	18.5 kW
	415 V	4 kW	5.5 kW	9 kW	11 kW	15 kW	18.5 kW
	440 V	4 kW	5.5 kW	9 kW	15 kW	18.5 kW	22 kW
	500 V	5.5 kW	7.5 kW	9 kW	15 kW	18.5 kW	22 kW
	690 V	5.5 kW	7.5 kW	9 kW	15 kW	18.5 kW	22 kW
	1000 V	-	-	-	-	-	-
Rated making capacity AC-3, AC-3e		10 x Ie AC-3, 12 x Ie AC-3e acc. to IEC 60947-4-1					
Rated breaking capacity AC-3, AC-3e		8 x Ie AC-3, 8.5 x Ie AC-3e acc. to IEC 60947-4-1					
AC-8a Utilization category (without thermal overload relay Ue 400 V 50/60 Hz $\theta \leq 40^\circ\text{C}$ )							
le / Rated operational current AC-8a		12 A	16 A	22 A	30 A	40 A	50 A
Rated operational power AC-8a		5.5 kW	7.5 kW	11 kW	15 kW	20 kW	25 kW
Short-circuit protection device for contactors without thermal overload relay in free air Motor protection excluded (2)							
Ue $\leq 500\text{ V AC - gG type fuse}$		25 A	32 A	32 A	50 A	63 A	63 A
Rated short-time withstand current Icw at 40 °C ambient temperature, in free air from a cold state							
	1 s	300 A	300 A	300 A	700 A	700 A	700 A
	10 s	150 A	150 A	150 A	350 A	350 A	350 A
	30 s	80 A	80 A	80 A	225 A	225 A	225 A
	1 min	60 A	60 A	60 A	150 A	150 A	150 A
	15 min	35 A	35 A	35 A	50 A	50 A	50 A
Maximum breaking capacity $\cos \phi = 0.45$							
	at 440 V	250 A	250 A	250 A	500 A	500 A	500 A
	at 690 V	106 A	106 A	106 A	200 A	200 A	200 A
Power dissipation per pole							
	le / AC-1	1.14 W	1.43 W	1.64 W	2 W	2.44 W	2.44 W
	le / AC-3, AC-3e	0.15 W	0.26 W	0.6 W	0.66 W	1 W	1.41 W
Max. electrical switching frequency							
	AC-1	600 cycles/h					
	AC-3, AC-3e	1200 cycles/h					
	AC-2, AC-4	300 cycles/h					150 cycles/h

(1) For the corresponding kW/A or hp/A values of 1500 r.p.m, 50 Hz or 1800 r.p.m, 60 Hz, 3-phase motors, see "Motor rated operational powers and currents".

(2) For the protection of motor starters against short circuits, see "Coordination with short-circuit protection devices".

## AF09..K ... AF38..K 3-pole contactors - with Push-in Spring terminals

### Technical data

#### Main pole - Utilization characteristics according to UL / NEMA / CSA

Contactor types	AC / DC operated	AF09..K	AF12..K	AF16..K	AF26..K	AF30..K	AF38..K
Standards		UL 60947-4-1, CSA-C22.2 No. 60947-4-1					
Maximum operational voltage		600 V					
NEMA size		00	0	-	1	-	-
NEMA continuous amp rating	Thermal current	9 A	18 A		27 A		
NEMA maximum horse power ratings							
1-phase, 60 Hz	115 V AC	1/3 hp	1 hp		2 hp		
	230 V AC	1 hp	2 hp		3 hp		
NEMA maximum horse power ratings							
3-phase, 60 Hz	200 V AC	1-1/2 hp	3 hp		7-1/2 hp		
	230 V AC	1-1/2 hp	3 hp		7-1/2 hp		
	460 V AC	2 hp	5 hp		10 hp		
	575 V AC	2 hp	5 hp		10 hp		
UL / CSA general use rating							
600 V AC		25 A	28 A	30 A	42 A	45 A	45 A
With conductor cross-sectional area		AWG 10	AWG 10	AWG 10	AWG 8	AWG 8	AWG 8
1 pole	80 V DC	25 A	28 A	30 A	42 A	45 A	45 A
2 poles in serie	160 V DC	25 A	28 A	30 A	42 A	45 A	45 A
3 poles in serie	240 V DC	25 A	28 A	30 A	42 A	45 A	45 A
With conductor cross-sectional area		AWG 10	AWG 10	AWG 10	AWG 8	AWG 8	AWG 8
UL / CSA maximum 1-phase motor rating							
Full load current	120 V AC	13.8 A	16 A	20 A	24 A	24 A	24 A
	240 V AC	10 A	12 A	17 A	17 A	28 A	28 A
Horse power rating	120 V AC	3/4 hp	1 hp	1-1/2 hp	2 hp	2 hp	2 hp
	240 V AC	1-1/2 hp	2 hp	3 hp	3 hp	5 hp	5 hp
UL / CSA maximum 3-phase motor rating							
Full load current (1)	200-208 V AC	7.8 A	11 A	17.5 A	25.3 A	32.2 A	32.2 A
	220-240 V AC	6.8 A	9.6 A	15.2 A	22 A	28 A	28 A
	440-480 V AC	7.6 A	11 A	14 A	21 A	27 A	34 A
	550-600 V AC	9 A	11 A	17 A	22 A	27 A	32 A
Horse power rating (1)	200-208 V AC	2 hp	3 hp	5 hp	7-1/2 hp	10 hp	10 hp
	220-240 V AC	2 hp	3 hp	5 hp	7-1/2 hp	10 hp	10 hp
	440-480 V AC	5 hp	7-1/2 hp	10 hp	15 hp	20 hp	25 hp
	550-600 V AC	7-1/2 hp	10 hp	15 hp	20 hp	25 hp	30 hp
UL / CSA - DC motor starting - 3 poles in series							
Full Load Amps (FLA)	125 V DC	9.5 A	13.2 A	17 A	25 A	25 A	25 A
	250 V DC	8.5 A	12.2 A	12.2 A	20 A	29 A	29 A
Horse power rating	125 V DC	1 hp	1-1/2 hp	2 hp	3 hp	3 hp	3 hp
	250 V DC	2 hp	3 hp	3 hp	5 hp	7-1/2 hp	7-1/2 hp
Short-circuit protection device for contactors without thermal overload relay							
Motor protection excluded							
Fuse rating		30 A		60 A		100 A	
Fuse type, 600 V		RK5					
Maximum electrical switching frequency							
For general use		600 cycles/h					
For motor use		1200 cycles/h					

(1) For the corresponding kW/A or hp/A values of 1500 r.p.m, 50 Hz or 1800 r.p.m, 60 Hz, 3-phase motors, see "Motor rated operational powers and currents".

## AF09..K ... AF38..K 3-pole contactors - with Push-in Spring terminals

### Technical data

#### Main pole - Utilization characteristics - 3 N.O. non reversing contactors

Contactor types	AC / DC operated	AF09..K	AF12..K	AF16..K	AF26..K	AF30..K	AF38..K
AC Resistance air heating							
Full Load Amps (FLA)	600 V AC	20 A	25 A	30 A	42 A	45 A	45 A
Elevator control, load switching, 500,000 electrical operating cycles acc. to CSA B44.1 / ASME 17.5 paragraph 19.2.1							
1-phase							
Horse power rating	110-120 V AC	1/4 hp	1/3 hp	–	1-1/2 hp	2 hp	2 hp
	220-240 V AC	1/2 hp	3/4 hp	–	3 hp	3 hp	5 hp
3-phase							
Horse power rating	200-208 V AC	1 hp	2 hp	–	5 hp	7-1/2 hp	7-1/2 hp
	220-240 V AC	1 hp	2 hp	–	5 hp	7-1/2 hp	10 hp
	440-480 V AC	3 hp	5 hp	–	15 hp	20 hp	20 hp
	550-600 V AC	3 hp	5 hp	–	15 hp	20 hp	20 hp
Elevator control, 500,000 mechanical operating cycles, 5 electrical operating cycles acc. to CSA B44.1 / ASME 17.5 paragraph 19.2.2							
1-phase							
Horse power rating	110-120 V AC	3/4 hp	1 hp	1-1/2 hp	2 hp	2 hp	3 hp
	220-240 V AC	1-1/2 hp	2 hp	3 hp	3 hp	5 hp	7-1/2 hp
3-phase							
Horse power rating	200-208 V AC	2 hp	3 hp	5 hp	7-1/2 hp	10 hp	10 hp
	220-240 V AC	2 hp	3 hp	5 hp	7-1/2 hp	10 hp	10 hp
	440-480 V AC	5 hp	7-1/2 hp	10 hp	15 hp	20 hp	25 hp
	550-600 V AC	7-1/2 hp	10 hp	15 hp	20 hp	25 hp	30 hp
Lighting application - UL/CSA							
Tungsten lamps							
1-phase per pole	347 V AC	20 A	25 A	30 A	42 A	45 A	45 A
3-phase break all lines	600 V AC	20 A	25 A	30 A	42 A	45 A	45 A
Electrical discharge lamps (ballast)							
1-phase per pole	347 V AC	20 A	25 A	30 A	42 A	45 A	45 A
3-phase break all lines	600 V AC	20 A	25 A	30 A	42 A	45 A	45 A

## AF09..K ... AF38..K 3-pole contactors - with Push-in Spring terminals

### Technical data

#### General technical data

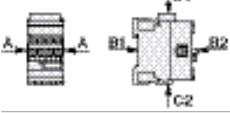
Contactor types	AC / DC operated	AF09..K	AF12..K	AF16..K	AF26..K	AF30..K	AF38..K
Rated insulation voltage $U_i$		690 V					
acc. to IEC 60947-4-1		600 V					
acc. to UL / CSA		6 kV					
Rated impulse withstand voltage $U_{imp}$ .		6 kV					
Electromagnetic compatibility		Devices complying with IEC 60947-1 / EN 60947-1 - Environment A and B (1)					
Ambient air temperature close to contactor							
Operation Without thermal overload relay		-40 ... +70 °C					
Storage		-60 ... +80 °C					
Climatic withstand		Category B according to IEC 60947-1 Annex Q					
Maximum operating altitude (without derating)		3000 m					
Mechanical durability							
Number of operating cycles		10 million operating cycles					
Maximum switching frequency		3600 cycles/h					
Shock withstand							
acc. to IEC 60068-2-27 and EN 60068-2-27							
Mounting position 1	Shock direction	1/2 sinusoidal shock for 11 ms: no change in contact position, closed or open position					
	A	30 g					
	B1	25 g closed position / 5 g open position					
	B2	15 g					
	C1	25 g					
	C2	25 g					
Vibration withstand		5 ... 300 Hz					
acc. to IEC 60068-2-6		4 g Closed position / 2 g Open position					

(1) AF09 ... AF38...-12 (48...130 V 50/60 Hz-DC) compliant to environment A only. For environment B: select AF09 ... AF38Z...-22.

#### Mounting characteristics and conditions for use

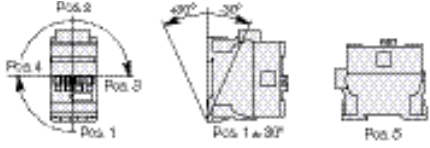
Contactor types	AC / DC operated	AF09..K	AF12..K	AF16..K	AF26..K	AF30..K	AF38..K
Mounting positions							
		Max. N.C. built-in and add-on N.C. auxiliary contacts: see accessory fitting details for a 3-pole contactor AF09 ... AF38					
Mounting distances		The contactors can be assembled side by side					
Fixing							
On rail according to IEC 60715, EN 60715		35 x 7.5 mm or 35 x 15 mm					
By screws (not supplied)		2 x M4 screws placed diagonally					

# AF09..K ... AF38..K 3-pole contactors - with Push-in Spring terminals

## Technical data

### Magnet System Characteristics for AF09..K ... AF38..K contactors - AC / DC operated

Contactor types	AC / DC operated	AF09..K	AF12..K	AF16..K	AF26..K	AF30..K	AF38..K
Coil operating limits acc. to IEC 60947-4-1	AC supply	At $\theta \leq 60^\circ\text{C}$ $0.85 \times U_c \text{ min} \dots 1.1 \times U_c \text{ max}$ .					
	DC supply	At $\theta \leq 70^\circ\text{C}$ $0.85 \times U_c \text{ min} \dots U_c \text{ max}$ .					
AC control voltage 50/60 Hz		At $\theta \leq 70^\circ\text{C}$ $0.85 \times U_c \text{ min} \dots U_c \text{ max}$ .					
Rated control circuit voltage $U_c$		24 ... 500 V AC					
Coil consumption	Average pull-in value	50 VA					
	Average holding value	2.2 VA / 2 W					
DC control voltage		20 ... 500 V DC					
Rated control circuit voltage $U_c$		20 ... 500 V DC					
Coil consumption	Average pull-in value	50 W					
	Average holding value	2 W					
PLC-output control		Not suitable for direct control by PLC-output					
Drop-out voltage		$\leq 60\% U_c \text{ min}$ .					
Operating time							
Between coil energization and:							
	N.O. contact closing	40 ... 95 ms					
	N.C. contact opening	38 ... 90 ms					
Between coil de-energization and:							
	N.O. contact opening	11 ... 95 ms					
	N.C. contact closing	13 ... 98 ms					

















### Magnet System Characteristics for AF09Z..K ... AF38Z..K contactors - for specific applications - coils 20, 21, 22, 23

Contactor types	AC / DC operated	AF09Z..K	AF12Z..K	AF16Z..K	AF26Z..K	AF30Z..K	AF38Z..K
Coil operating limits acc. to IEC 60947-4-1	AC supply	At $\theta \leq 60^\circ\text{C}$ $0.85 \times U_c \text{ min} \dots 1.1 \times U_c \text{ max}$					
	DC supply	At $\theta \leq 70^\circ\text{C}$ $0.85 \times U_c \text{ min} \dots U_c \text{ max}$					
AC control voltage 50/60 Hz		At $\theta \leq 70^\circ\text{C}$ $0.85 \times U_c \text{ min} \dots 1.1 \times U_c \text{ max}$					
Rated control circuit voltage $U_c$		24 ... 250 V AC					
Coil consumption	Average pull-in value	16 VA					
	Average holding value	1.7 VA / 1.5 W					
DC control voltage		12 ... 250 V DC					
Rated control circuit voltage $U_c$		12 ... 250 V DC					
Coil consumption	Average pull-in value	12 ... 16 W					
	Average holding value	1.7 W					
PLC-output control		(AF..Z coil 21) $\geq 500 \text{ mA}$ 24 V DC for PLCs - Not suitable for safety PLCs					
Drop-out voltage		$\leq 60\%$ of $U_c \text{ min}$ .					
Voltage sag immunity acc. to SEMI F47-0706		(AF..Z coil 21, 22, 23) conditions of use on request					
Dips withstand $-20^\circ\text{C} \leq \theta \leq +60^\circ\text{C}$		(AF..Z coil 21, 22, 23) 20 ms average for $U_c \geq 24 \text{ V}$ 50/60 Hz or $U_c \geq 20 \text{ V}$ DC					
Operating time							
Between coil energization and:							
	N.O. contact closing	40 ... 95 ms					
	N.C. contact opening	38 ... 90 ms					
Between coil de-energization and:							
	N.O. contact opening	11 ... 95 ms					
	N.C. contact closing	13 ... 98 ms					

## AF09..K ... AF38..K 3-pole contactors - with Push-in Spring terminals

### Technical data

#### Connecting characteristics

Contactor types	AC / DC operated	AF09..K	AF12..K	AF16..K	AF26..K	AF30..K	AF38..K
Main terminals		 Push-in Spring terminals					
Connection capacity (min. ... max.)							
Main conductors (poles)							
 Rigid Solid ( $\leq 2.5 \text{ mm}^2$ )	1 x	1 ... 6 mm <sup>2</sup>				1 ... 10 mm <sup>2</sup>	
 Rigid Stranded ( $\geq 4 \text{ mm}^2$ )	2 x	1 ... 6 mm <sup>2</sup>				1 ... 10 mm <sup>2</sup>	
 Flexible with non insulated ferrule	1 x	1 (push-in) / 0.5 (spring) ... 4 mm <sup>2</sup>					
 Flexible with non insulated ferrule	2 x	1 (push-in) / 0.5 (spring) ... 4 mm <sup>2</sup>					
 Flexible with insulated ferrule	1 x	1 (push-in) / 0.5 (spring) ... 4 mm <sup>2</sup>					
 Flexible with insulated ferrule	2 x	1 (push-in) / 0.5 (spring) ... 2.5 mm <sup>2</sup>					
 Flexible without ferrule	1 x	(spring) 0.5 ... 4 mm <sup>2</sup>					
 Flexible without ferrule	2 x	(spring) 0.5 ... 4 mm <sup>2</sup>					
Connection capacity acc. to UL/CSA (Solid $\leq$ AWG 14)	1 or 2 x	AWG 18 ... 10				AWG 18 ... 8	
Stripping length		12 mm				14 mm	
Auxiliary conductors (built-in auxiliary terminals + coil terminals)							
 Rigid solid	1 x	1 ... 2.5 mm <sup>2</sup>					
 Rigid solid	2 x	1 ... 2.5 mm <sup>2</sup>					
 Flexible with non insulated ferrule	1 x	1 (push-in) / 0.5 (spring) ... 2.5 mm <sup>2</sup>					
 Flexible with non insulated ferrule	2 x	1 (push-in) / 0.5 (spring) ... 2.5 mm <sup>2</sup>					
 Flexible with insulated ferrule	1 x	1 (push-in) / 0.5 (spring) ... 1.5 mm <sup>2</sup>					
 Flexible with insulated ferrule	2 x	1 (push-in) / 0.5 (spring) ... 1.5 mm <sup>2</sup>					
 Flexible without ferrule	1 x	(spring) 0.5 ... 2.5 mm <sup>2</sup>					
 Flexible without ferrule	2 x	(spring) 0.5 ... 2.5 mm <sup>2</sup>					
Connection capacity acc. to UL/CSA	1 or 2 x	AWG 18 ... 14					
Stripping length		10 mm					
Degree of protection acc. to IEC 60947-1 / EN 60947-1 and IEC 60529 / EN 60529							
Main terminals		IP20					
Coil terminals		IP20					
Built-in auxiliary terminals		IP20					
Screwdriver type	All terminals	Flat $\varnothing$ 3 mm x 0.5 mm					

## AF09..K ... AF38..K 3-pole contactors - with Push-in Spring terminals

### Technical data

#### Built-in auxiliary contacts according to IEC

Contactor types	AC / DC operated	AF09..K	AF12..K	AF16..K	AF26..K	AF30..K	AF38..K
Rated operational voltage Ue max.		690 V					
Rated frequency (without derating)		50 / 60 Hz					
Conventional free air thermal current Ith - $\theta \leq 40^\circ\text{C}$		16 A					
le / Rated operational current AC-15		6 A					
acc. to IEC 60947-5-1	24-127 V 50/60 Hz	4 A					
	220-240 V 50/60 Hz	3 A					
	400-440 V 50/60 Hz	2 A					
	500 V 50/60 Hz	2 A					
	690 V 50/60 Hz	2 A					
Making capacity AC-15		10 x le AC-15 acc. to IEC 60947-5-1					
Breaking capacity AC-15		10 x le AC-15 acc. to IEC 60947-5-1					
le / Rated operational current DC-13		6 A / 144 W					
acc. to IEC 60947-5-1	24 V DC	2.8 A / 134 W					
	48 V DC	1 A / 72 W					
	72 V DC	0.55 A / 60 W					
	110 V DC	0.55 A / 69 W					
	125 V DC	0.27 A / 60 W					
	220 V DC	0.27 A / 68 W					
	250 V DC	0.15 A / 60 W					
	400 V DC	0.13 A / 65 W					
	500 V DC	0.1 A / 60 W					
	600 V DC						
Short-circuit protection device gG type fuse		10 A					
Rated short-time withstand current Icw	for 1.0 s	100 A					
	for 0.1 s	140 A					
Minimum switching capacity with failure rate acc. to IEC 60947-5-4		12 V / 3 mA					
Non-overlapping time between N.O. and N.C. contacts		$\geq 2$ ms					
Power dissipation per pole at 6 A		0.1 W					
Maximum electrical switching frequency	AC-15	1200 cycles/h					
	DC-13	900 cycles/h					
Mechanically linked contacts acc. to annex L of IEC 60947-5-1		Built-in N.O. or N.C. auxiliary contacts and additional N.O. or N.C. auxiliary contacts (CA4, CAL4 aux. contact blocks) are mechanically linked contacts.					
Mirror contacts acc. to annex F of IEC 60947-4-1		Built-in N.C. auxiliary contacts or additional N.C. auxiliary contacts (CA4, CAL4 aux. contact blocks) are mirror contacts.					

#### Built-in auxiliary contacts according to UL / CSA

Contactor types	AC / DC operated	AF09..K	AF12..K	AF16..K	AF26..K	AF30..K	AF38..K
Maximum operational voltage		600 V AC, 600 V DC					
Pilot duty		A600, Q600					
AC thermal rated current		10 A					
AC maximum volt-ampere making		7200 VA					
AC maximum volt-ampere breaking		720 VA					
DC thermal rated current		2.5 A					
DC maximum volt-ampere making-breaking		69 VA					

## AF09..K ... AF38..K 3-pole contactors with Push-in Spring terminals

### Electrical durability and utilization categories

#### General

Utilization categories determine the current making and breaking conditions relating to the characteristics of the loads to be controlled by the contactors. International standard IEC 60947-4-1 and European standard EN 60947-4-1 are the standards to be referred to.

If  $I_c$  is the current to be broken by the contactor and  $I_e$  the rated operational current normally drawn by the load, then:

- Categories AC-1 and AC-3  $I_c = I_e$
- Category AC-2  $I_c = 2.5 \times I_e$
- Category AC-4  $I_c = 6 \times I_e$

Generally speaking  $I_c = m \times I_e$  where  $m$  is a multiple of the load operational current.

On next pages, the curves corresponding to categories AC-1, AC-3 and AC-4 represent the electrical durability variation of standard contactors in relation to the breaking current  $I_c$ . Electrical durability is expressed in millions of operating cycles.

#### Curve utilization mode

Electrical durability forecast and contactor selection for categories AC-1, AC-2, AC-3 or AC-4

Characteristics	Load to be controlled
Operational voltage	$U_e$
Current normally drawn	$I_e$ ( $U_e / I_e / \text{kW}$ relation for motors, see "Motor rated operational powers and currents")
Utilization category	AC-1, AC-2, AC-3 or AC-4
Breaking current	$I_c = I_e$ for AC-1 and for AC-3; $I_c = 2.5 \times I_e$ for AC-2; $I_c = 6 \times I_e$ for AC-4

- Define the number of operating cycles  $N$  required.
- On the diagram corresponding to the operational category, select the contactor with the curve immediately above the intersection point ( $I_c ; N$ ).

#### Electrical durability forecast and contactor selection for mixed duty motor control: AC-3 ( $I_c = I_e$ ) type switching off while "motor running" and, occasionally, AC-4 ( $I_c = 6 \times I_e$ ) type switching off while "motor accelerating"

Characteristics	Load to be controlled
Operational voltage	$U_e$
Current normally drawn while "motor running"	$I_e$ ( $U_e / I_e / \text{kW}$ relation for motors, see "Motor rated operational powers and currents")
Utilization category	AC-1, AC-2, AC-3 or AC-4
Breaking current for AC-3	$I_c = I_e$
Breaking current for AC-4 while "motor accelerating"	$I_c = 6 \times I_e$
Percentage of AC-4 operating cycles	$K$ (on the basis of the total number of operating cycles)

- Define the total number of operating cycles  $N$  required.
- Note the smallest contactor rating compatible for AC-3 ( $U_e / I_e$ ) on Main pole utilization characteristic table (see "Technical data").
- For the selected contactor make a note of the following in relation to the voltage using diagram AC-3 in next pages:
  - The number of operating cycles  $A$  for  $I_c = I_e$  (AC-3)
  - The number of operating cycles  $B$  for  $I_c = 6 \times I_e$  (AC-4)
- Calculate the estimated number of cycles  $N'$  ( $N'$  is always below  $A$ )

$$N' = \frac{A}{1 + 0.01 K (A/B - 1)}$$

- If  $N'$  is too low in relation to the target  $N$ , calculate the estimated number of cycles for a higher contactor rating.

#### Case of uninterrupted duty

For uninterrupted duty, some verifications of preventing maintenance are necessary to check the functionality of the concerned product (consult us).

The combined effect of environmental conditions and the proper temperature of the product may require some disposals. As a matter of fact, for this duty, the use duration prevails over the number of operating cycles.

## AF09..K ... AF38..K 3-pole contactors - with Push-in Spring terminals

### Electrical durability

#### Electrical Durability for AC-1 Utilization Category - $U_e \leq 690$ V.

Switching non-inductive or slightly inductive loads. The breaking current  $I_c$  for AC-1 is equal to the rated operational current of the load.

Ambient temperature and maximum electrical switching frequency: see "Technical Data".

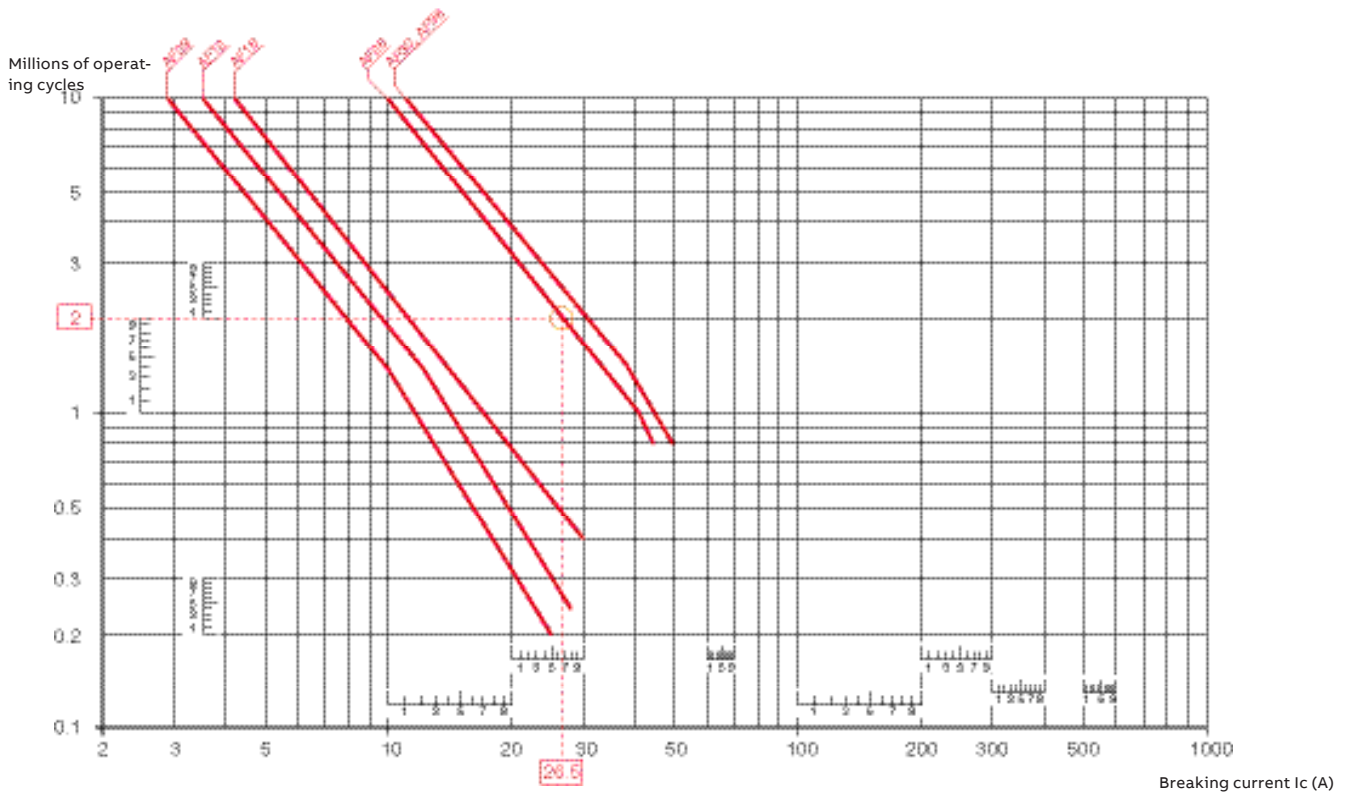

#### Example:

$I_c / AC-1 = 26.5$  A – Electrical durability required = 2 millions operating cycles.

Using the AC-1 curves above select the AF26 contactor at intersection "O" (26.5 A / 2 millions operating cycles).

# AF09..K ... AF38..K 3-pole contactors - with Push-in Spring terminals

## Electrical durability

### Electrical Durability for AC-3 Utilization Category

Switching cage motors: starting and switching off running motors. The breaking current  $I_c$  for AC-3 is equal to the rated operational current  $I_e$  ( $I_e$  = motor full load current). Ambient temperature and maximum electrical switching frequency: see "Technical Data".

### AC-3 - $U_e \leq 440$ V

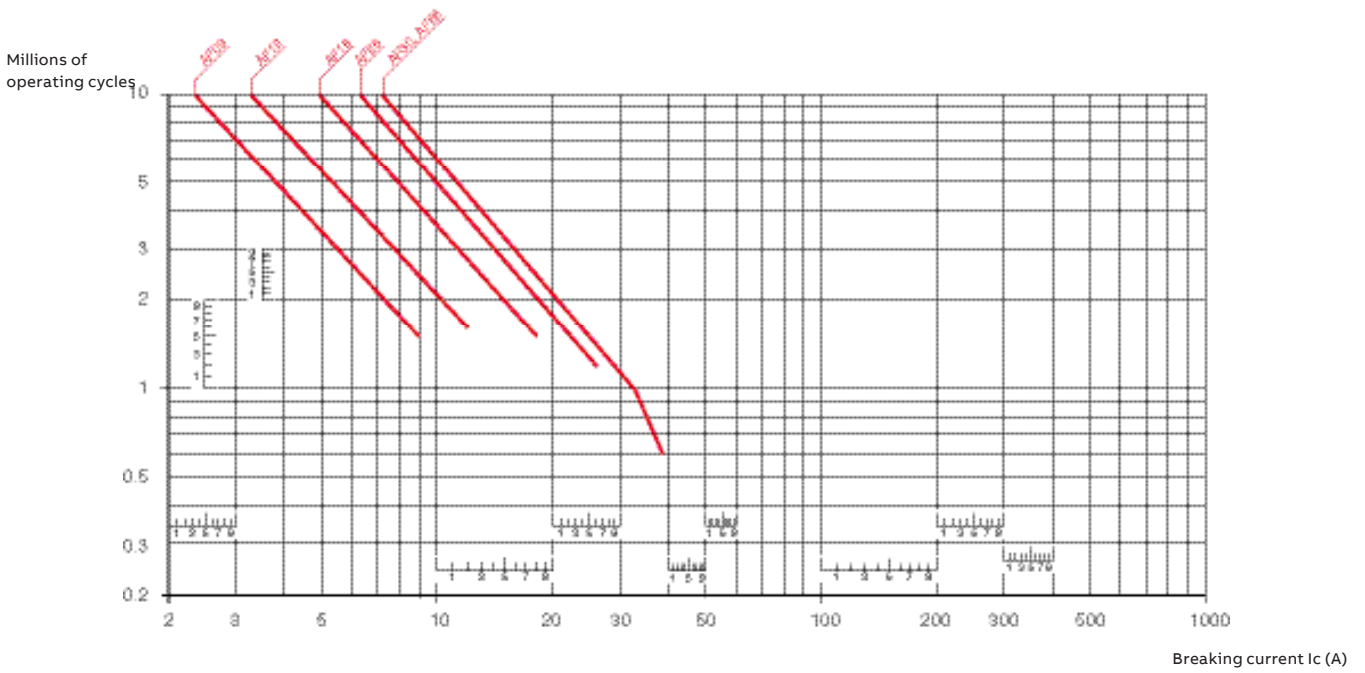

### AC-3 - $440$ V < $U_e \leq 690$ V

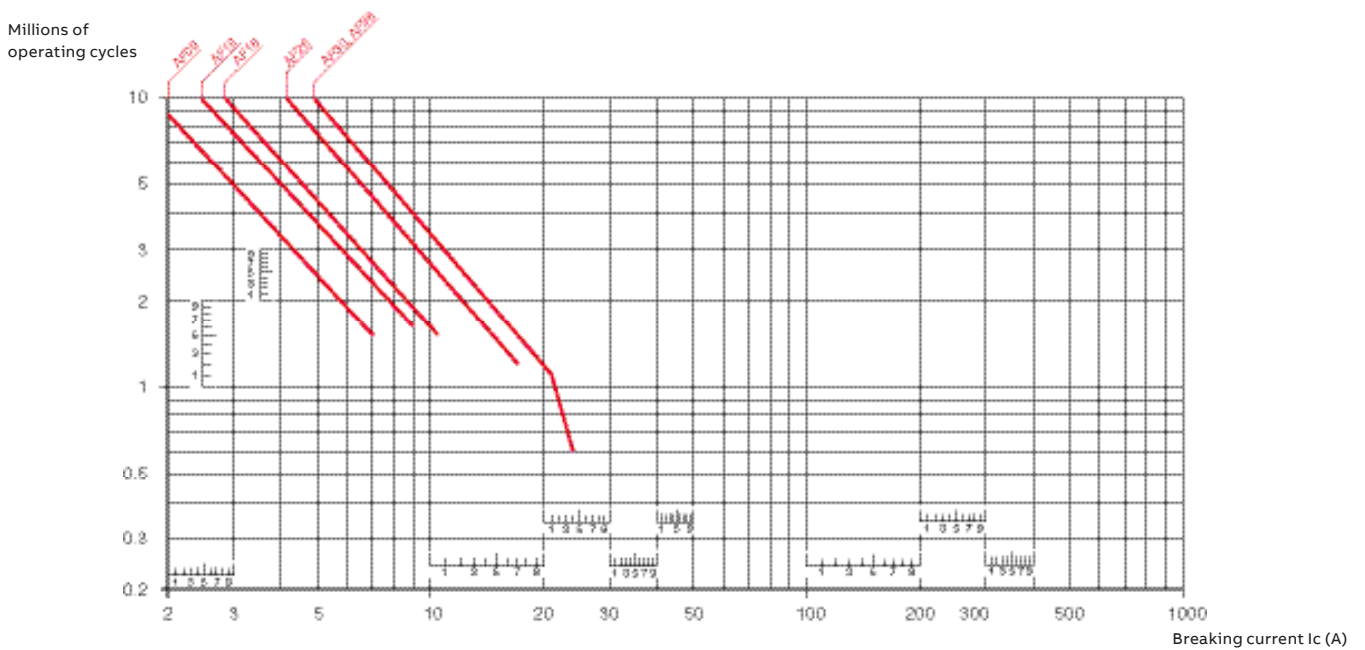

# AF09..K ... AF38..K 3-pole contactors - with Push-in Spring terminals

## Electrical durability

### Electrical Durability for AC-2 or AC-4 Utilization Category

Switching cage motors: starting reverse operation and step-by-step operation. The breaking current  $I_c$  is equal to  $2.5 \times I_e$  for AC-2 and  $6 \times I_e$  for AC-4, keeping in mind that  $I_e$  is the motor rated operational current ( $I_e$  = motor full load current).

Ambient temperature  $\leq 60^\circ\text{C}$ . Maximum electrical switching frequency: see "Technical Data".

### AC-2 or AC-4 - $U_e \leq 440\text{ V}$

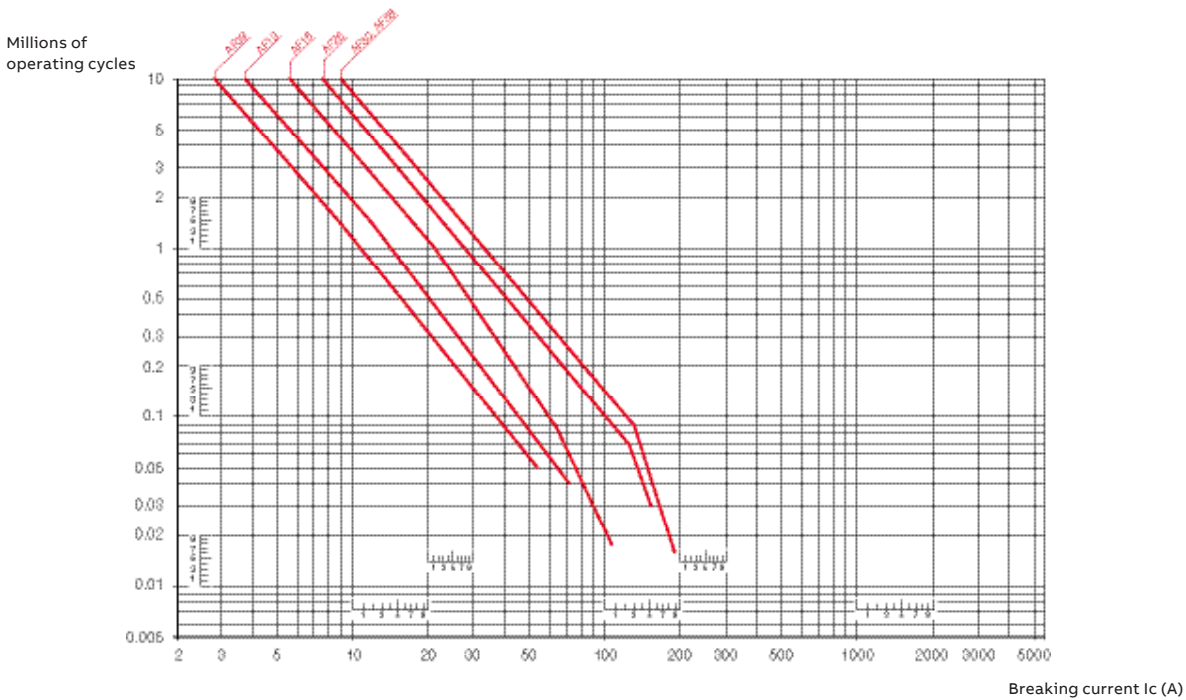

### AC-2 or AC-4 - $440\text{ V} < U_e \leq 690\text{ V}$

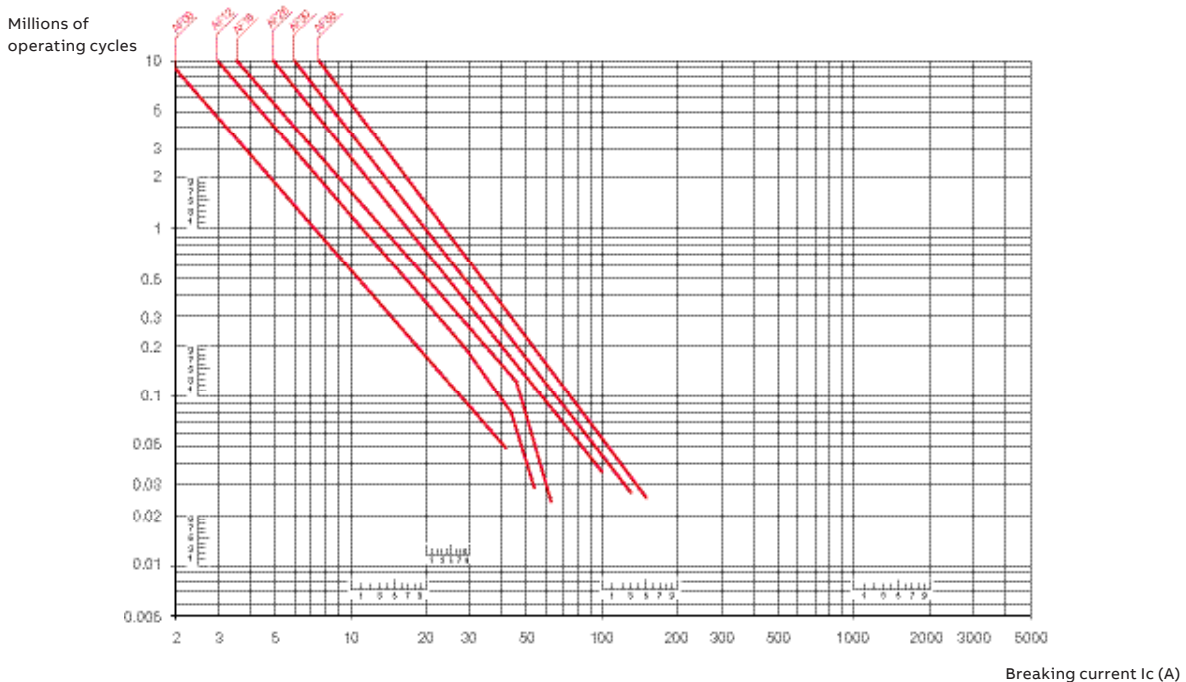

# AF09..K ... AF38..K 3-pole contactors - with Push-in Spring terminals

## Terminal marking and positioning

### AF09..K ... AF38..K contactors - AC / DC operated

Standard devices without addition of auxiliary contacts

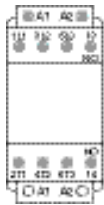

AF09 ... AF16..-30-10K

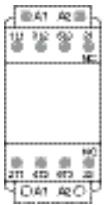

AF09 ... AF16..-30-01K

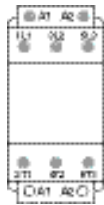

AF26 ... AF38..-30-00K

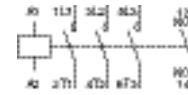

AF09 ... AF16..-30-10K

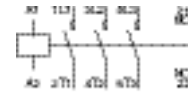

AF09 ... AF16..-30-01K

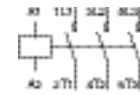

AF26 ... AF38..-30-00K

### Other possible contact combinations with auxiliary contacts added by the user

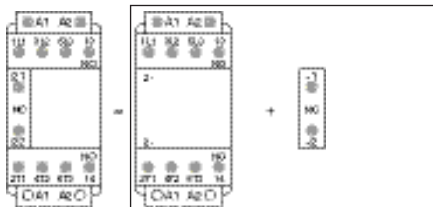

Combination 11 = AF09 ... AF16..-30-10K + CA4-01K

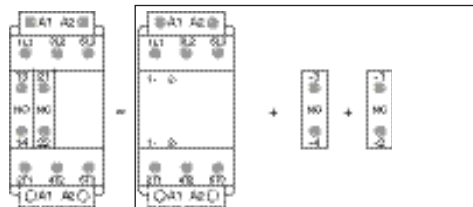

Combination 11 = AF26 ... AF38..-30-00K + CA4-10K + CA4-01K

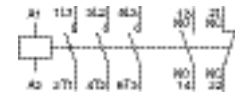

Combination 11

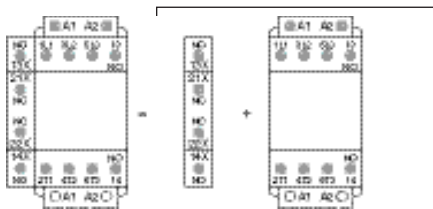

Combination 21 = CAL4-11K + AF09 ... AF16..-30-10K

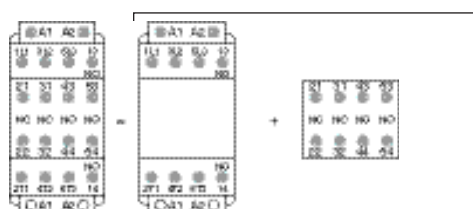

Combination 32 = AF09 ... AF16..-30-10K + CA4-22MK

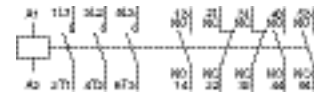

Combination 32

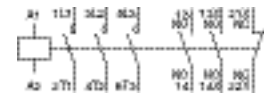

Combination 21

Note: Only AF..Z contactor with DC control voltage 12...20 V DC need to respect the connection polarities indicated close to the coil terminals: A1+ for the positive pole and A2- for the negative pole

# AF09..K ... AF38..K add-on auxiliary contacts - with Push-in Spring terminals

## Terminal marking and positioning

### 1-pole auxiliary contacts

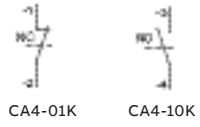

### 2-pole auxiliary contacts

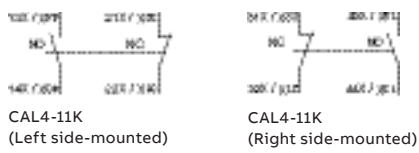

### 4-pole auxiliary contacts



# AF09..K, AF16..K 3-pole contactors - with Push-in Spring terminals

## Dimensions

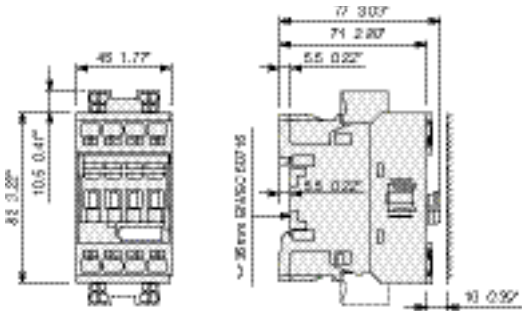

AF09..K, AF12..K, AF16..K

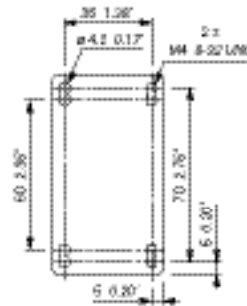

AF09..K, AF12..K, AF16..K

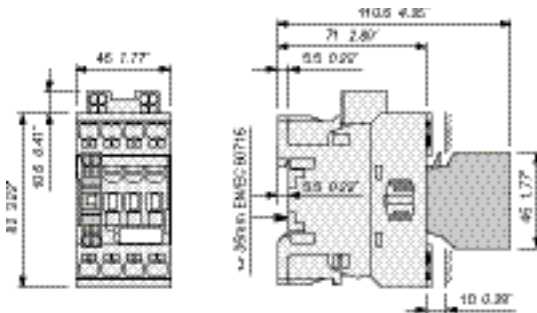

AF09..K, AF12..K, AF16..K  
+ CA4..K 1-pole auxiliary contact block

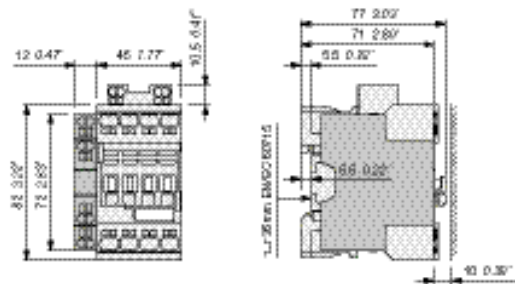

AF09..K, AF12..K, AF16..K+ CA4..K 1-pole auxiliary contact block

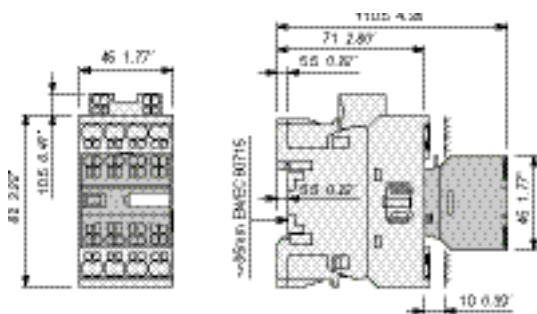

AF09..K, AF16..K  
+ CA4..K 4-pole auxiliary contact block

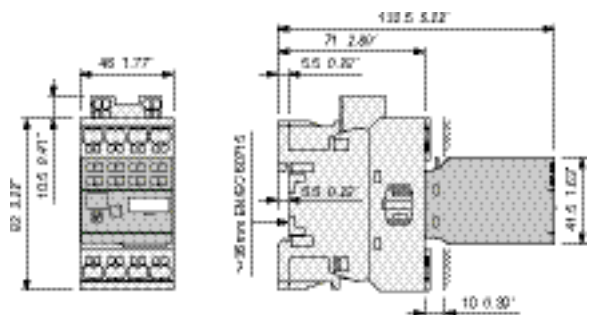

AF09..K, AF16..K  
+ TEF45 electronic timer

# AF26..K, AF30..K, AF38..K 3-pole contactors - with Push-in Spring terminals

## Dimensions

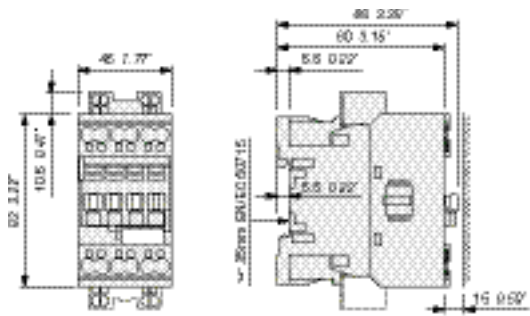

AF26..K, AF30..K, AF38..K

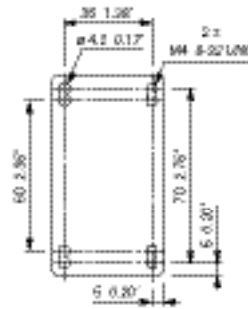

AF26..K, AF30..K, AF38..K

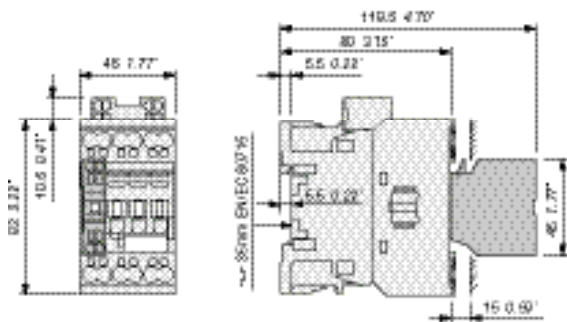

AF26..K, AF30..K, AF38..K  
+ CA4..K 1-pole auxiliary contact block

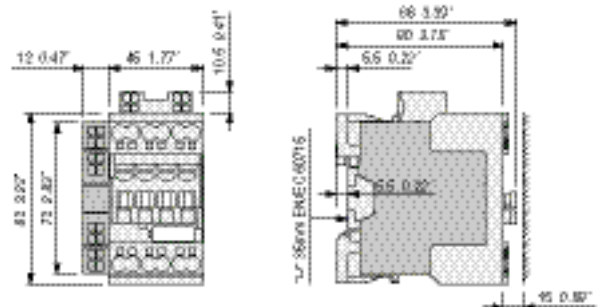

AF26..K, AF30..K, AF38..K  
+ CAL4-11K 2-pole auxiliary contact block

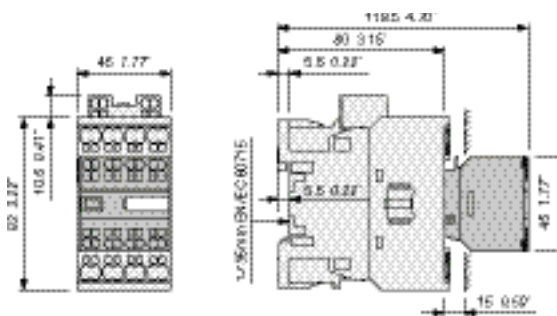

AF26..K, AF30..K, AF38..K  
+ CA4..K 4-pole auxiliary contact block

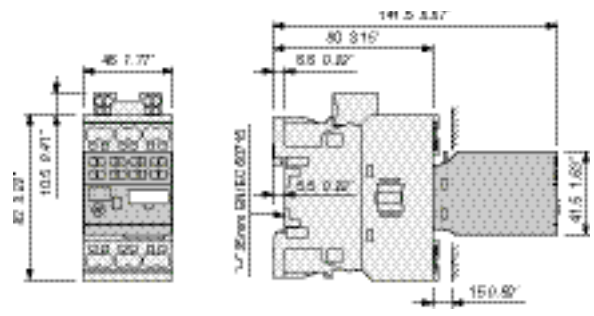

AF26..K, AF30..K, AF38..K  
+ TEF4S electronic timer

Note: For AF26..K ... AF38..K contactors, lateral distance to grounded component 2 mm 0.08" min  
24 V DC operated contactor (coil 30) depth + 20 mm (0.79").



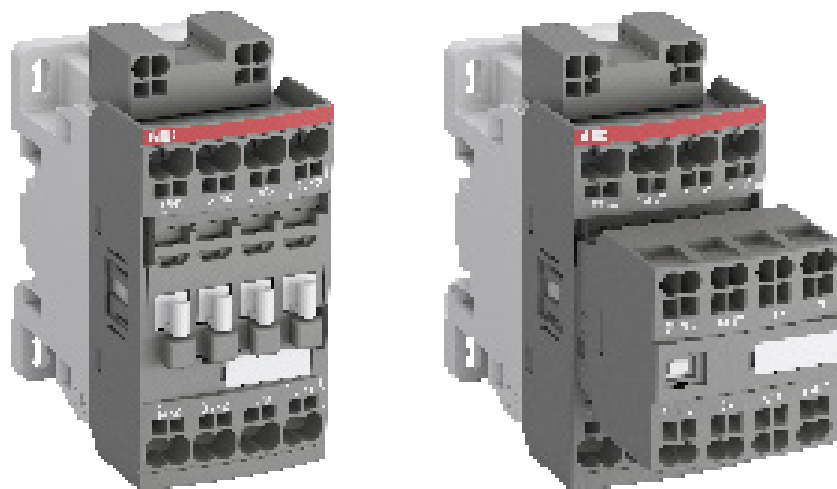

---

# NF..K contactor relays

<b>51</b>	<b>Ordering details</b>
<b>54</b>	<b>Main accessories</b>
<b>56</b>	<b>Technical data</b>
<b>59</b>	<b>Terminal marking and positioning</b>
<b>61</b>	<b>Dimensions</b>

# NF..K contactor relays - with Push-in Spring terminals

AC / DC operated

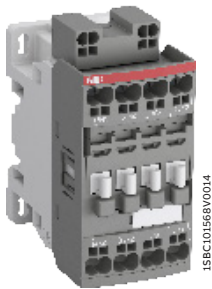

NF22EK

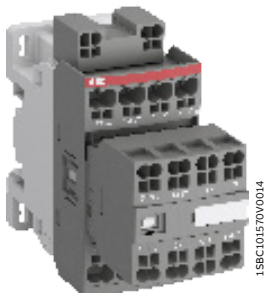

NF44EK

NF..K contactor relays are used for switching auxiliary and control circuits. These contactor relays are of the block type design with:

- 4 poles and 8 poles with a permanently fixed 4-pole auxiliary contact block.
- Contactor relays have mechanically linked auxiliary contact elements (side-marked symbol)
- control circuit: AC or DC operated with electronic coil interface accepting a wide control voltage range (e.g. 100...250 V AC and DC)
  - can manage large control voltage variations
  - only 4 control voltage ranges covering 24...500 V 50/60 Hz and 20...500 V DC
  - reduced panel energy consumption
  - very distinct closing and opening
- built-in surge suppression
- add-on auxiliary contact blocks for front or side mounting and a wide range of accessories.

Number of contacts	Rated control circuit voltage		Type	Order code	Weight
	Uc min. ... Uc max.	V 50/60 Hz   V DC			

4-pole contactor relays

	24 ... 60	20 ... 60 (1)	NF22EK-11	1SBH137005R1122	0.285
	48 ... 130	48 ... 130	NF22EK-12	1SBH137005R1222	0.285
	100 ... 250	100 ... 250	NF22EK-13	1SBH137005R1322	0.285
	250 ... 500	250 ... 500	NF22EK-14	1SBH137005R1422	0.325
	24 ... 60	20 ... 60 (1)	NF31EK-11	1SBH137005R1131	0.285
	48 ... 130	48 ... 130	NF31EK-12	1SBH137005R1231	0.285
	100 ... 250	100 ... 250	NF31EK-13	1SBH137005R1331	0.285
	250 ... 500	250 ... 500	NF31EK-14	1SBH137005R1431	0.325
	24 ... 60	20 ... 60 (1)	NF40EK-11	1SBH137005R1140	0.285
	48 ... 130	48 ... 130	NF40EK-12	1SBH137005R1240	0.285
	100 ... 250	100 ... 250	NF40EK-13	1SBH137005R1340	0.285
	250 ... 500	250 ... 500	NF40EK-14	1SBH137005R1440	0.325

8-pole contactor relays

	24 ... 60	20 ... 60 (1)	NF44EK-11	1SBH137005R1144	0.330
	48 ... 130	48 ... 130	NF44EK-12	1SBH137005R1244	0.330
	100 ... 250	100 ... 250	NF44EK-13	1SBH137005R1344	0.330
	250 ... 500	250 ... 500	NF44EK-14	1SBH137005R1444	0.370
	24 ... 60	20 ... 60 (1)	NF53EK-11	1SBH137005R1153	0.330
	48 ... 130	48 ... 130	NF53EK-12	1SBH137005R1253	0.330
	100 ... 250	100 ... 250	NF53EK-13	1SBH137005R1353	0.330
	250 ... 500	250 ... 500	NF53EK-14	1SBH137005R1453	0.370
	24 ... 60	20 ... 60 (1)	NF62EK-11	1SBH137005R1162	0.330
	48 ... 130	48 ... 130	NF62EK-12	1SBH137005R1262	0.330
	100 ... 250	100 ... 250	NF62EK-13	1SBH137005R1362	0.330
	250 ... 500	250 ... 500	NF62EK-14	1SBH137005R1462	0.370
	24 ... 60	20 ... 60 (1)	NF71EK-11	1SBH137005R1171	0.330
	48 ... 130	48 ... 130	NF71EK-12	1SBH137005R1271	0.330
	100 ... 250	100 ... 250	NF71EK-13	1SBH137005R1371	0.330
	250 ... 500	250 ... 500	NF71EK-14	1SBH137005R1471	0.370
	24 ... 60	20 ... 60 (1)	NF80EK-11	1SBH137005R1180	0.330
	48 ... 130	48 ... 130	NF80EK-12	1SBH137005R1280	0.330
	100 ... 250	100 ... 250	NF80EK-13	1SBH137005R1380	0.330
	250 ... 500	250 ... 500	NF80EK-14	1SBH137005R1480	0.370

(1) NF..K-11 not suitable for direct control by PLC-output.

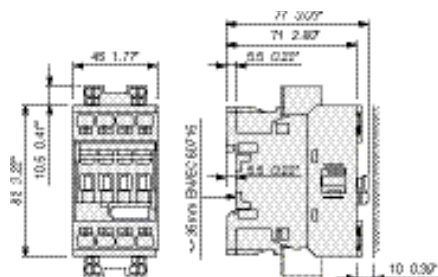

NF22EK, NF31EK, NF40EK

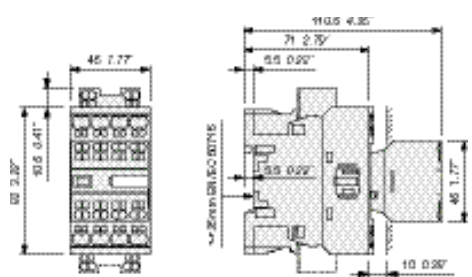

NF44EK, NF53EK, NF62EK, NF71EK, NF80EK

Main dimensions mm, inches

# NFZ..K contactor relays - with Push-in Spring terminals

24 V DC operated designed for PLC



1SBCC01649V00014

NFZ22EK-30



1SBCC01651V0014

NFZ44EK-30

NFZ contactor relays are used for switching auxiliary and control circuits.

These contactor relays are of the block type design with 4 poles or 8 poles (with a permanently fixed 4-pole auxiliary contact block).

- contactor relays have mechanically linked auxiliary contact elements (side-marked symbol)
- control circuit: 24 V DC operated with electronic coil interface allowing low holding consumption up to 1.7 W and reduced panel energy consumption
  - allow direct control by PLC-output  $\geq 250$  mA 24 V DC
  - very distinct closing and opening
- built-in surge suppression
- add-on auxiliary contact blocks for front or side mounting and a wide range of accessories.

Number of contacts	Rated control circuit voltage Uc min. ... Uc max.	Type	Order code	Weight Pkg (1 pce) kg
<b>4-pole contactor relays</b>				
	24	NFZ22EK-30	1SBH136005R3022	0.435
	24	NFZ31EK-30	1SBH136005R3031	0.435
	24	NFZ40EK-30	1SBH136005R3040	0.435
<b>8-pole contactor relays</b>				
	24	NFZ44EK-30	1SBH136005R3044	0.490
	24	NFZ53EK-30	1SBH136005R3053	0.490
	24	NFZ62EK-30	1SBH136005R3062	0.490
	24	NFZ71EK-30	1SBH136005R3071	0.490
	24	NFZ80EK-30	1SBH136005R3080	0.490

Note: NFZ contactor relays with 24 V DC control voltage need to respect the connection polarities indicated close to the coil terminals: A1+ for the positive pole and A2- for the negative pole.  
For product availability, please consult your ABB local sales organization.

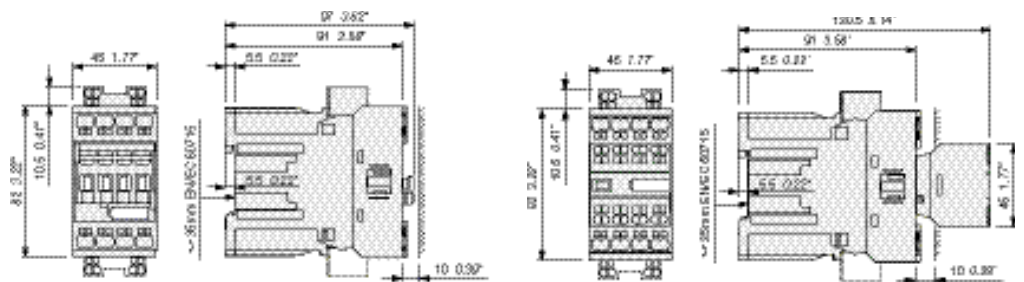

NFZ22EK, NFZ31EK, NFZ40EK

NFZ44EK, NFZ53EK, NFZ62EK, NFZ71EK, NFZ80EK

Main dimensions mm, inches

1SBCC01650S0201

# NFZ..K contactor relays - with Push-in Spring terminals

AC / DC operated for specific applications

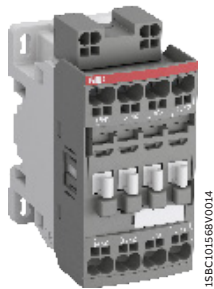

NFZ22EK

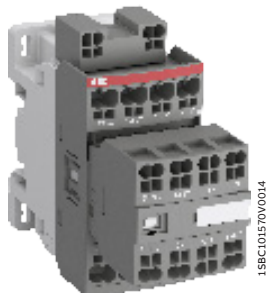

NFZ44EK

NFZ..K contactor relays are used for switching auxiliary and control circuits. These contactor relays are of the block type design with:

- 4 poles and 8 poles with a permanently fixed 4-pole auxiliary contact block.
- Contactor relays have mechanically linked auxiliary contact elements (side-marked symbol)
- control circuit: AC or DC operated with electronic coil interface accepting a wide control voltage range (e.g. 100...250 V AC and DC)
  - can manage large control voltage variations
  - only 4 control voltage ranges covering 24...250 V 50/60 Hz and 12...250 V DC
  - allow direct control by PLC-output  $\geq 24$  V DC 500 mA
  - reduced panel energy consumption
  - very distinct closing and opening
  - can withstand short voltage dips and voltage sags (SEMI F47-0706 conditions of use on request).
- built-in surge suppression
- add-on auxiliary contact blocks for front or side mounting and a wide range of accessories.

Number of contacts	Rated control circuit voltage		Type	Order code	Weight Pkg (1 pce) kg
	Uc min.	Uc max.			
	V 50/60 Hz	V DC			

### 4-pole contactor relays

	-	12 ... 20	NFZ22EK-20	1SBH136005R2022	0.315
	24 ... 60	20 ... 60	NFZ22EK-21	1SBH136005R2122	0.315
	48 ... 130	48 ... 130	NFZ22EK-22	1SBH136005R2222	0.315
	100 ... 250	100 ... 250	NFZ22EK-23	1SBH136005R2322	0.315
	-	12 ... 20	NFZ31EK-20	1SBH136005R2031	0.315
	24 ... 60	20 ... 60	NFZ31EK-21	1SBH136005R2131	0.315
	48 ... 130	48 ... 130	NFZ31EK-22	1SBH136005R2231	0.315
	100 ... 250	100 ... 250	NFZ31EK-23	1SBH136005R2331	0.315
	-	12 ... 20	NFZ40EK-20	1SBH136005R2040	0.315
	24 ... 60	20 ... 60	NFZ40EK-21	1SBH136005R2140	0.315
	48 ... 130	48 ... 130	NFZ40EK-22	1SBH136005R2240	0.315
	100 ... 250	100 ... 250	NFZ40EK-23	1SBH136005R2340	0.315

### 8-pole contactor relays

	-	12 ... 20	NFZ44EK-20	1SBH136005R2044	0.360
	24 ... 60	20 ... 60	NFZ44EK-21	1SBH136005R2144	0.360
	48 ... 130	48 ... 130	NFZ44EK-22	1SBH136005R2244	0.360
	100 ... 250	100 ... 250	NFZ44EK-23	1SBH136005R2344	0.360
	-	12 ... 20	NFZ53EK-20	1SBH136005R2053	0.360
	24 ... 60	20 ... 60	NFZ53EK-21	1SBH136005R2153	0.360
	48 ... 130	48 ... 130	NFZ53EK-22	1SBH136005R2253	0.360
	100 ... 250	100 ... 250	NFZ53EK-23	1SBH136005R2353	0.360
	-	12 ... 20	NFZ62EK-20	1SBH136005R2062	0.360
	24 ... 60	20 ... 60	NFZ62EK-21	1SBH136005R2162	0.360
	48 ... 130	48 ... 130	NFZ62EK-22	1SBH136005R2262	0.360
	100 ... 250	100 ... 250	NFZ62EK-23	1SBH136005R2362	0.360
	-	12 ... 20	NFZ71EK-20	1SBH136005R2071	0.360
	24 ... 60	20 ... 60	NFZ71EK-21	1SBH136005R2171	0.360
	48 ... 130	48 ... 130	NFZ71EK-22	1SBH136005R2271	0.360
	100 ... 250	100 ... 250	NFZ71EK-23	1SBH136005R2371	0.360
	-	12 ... 20	NFZ80EK-20	1SBH136005R2080	0.360
	24 ... 60	20 ... 60	NFZ80EK-21	1SBH136005R2180	0.360
	48 ... 130	48 ... 130	NFZ80EK-22	1SBH136005R2280	0.360
	100 ... 250	100 ... 250	NFZ80EK-23	1SBH136005R2380	0.360

Note: NFZ contactor relays with 12...20 V DC control voltage need to respect the connection polarities indicated close to the coil terminals: A1+ for the positive pole and A2- for the negative pole.

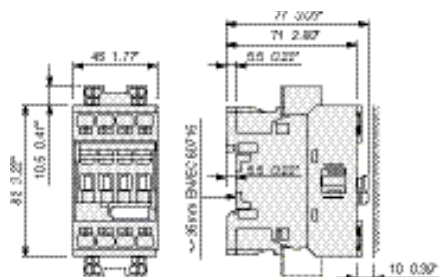

NFZ22EK, NFZ31EK, NFZ40EK

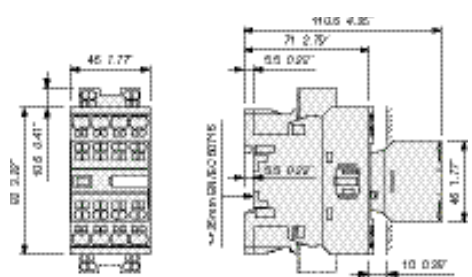

NFZ44EK, NFZ53EK, NFZ62EK, NFZ71EK, NFZ80EK

Main dimensions mm, inches

# NF..K contactor relays - with Push-in Spring terminals

## Contactor relays and main accessories

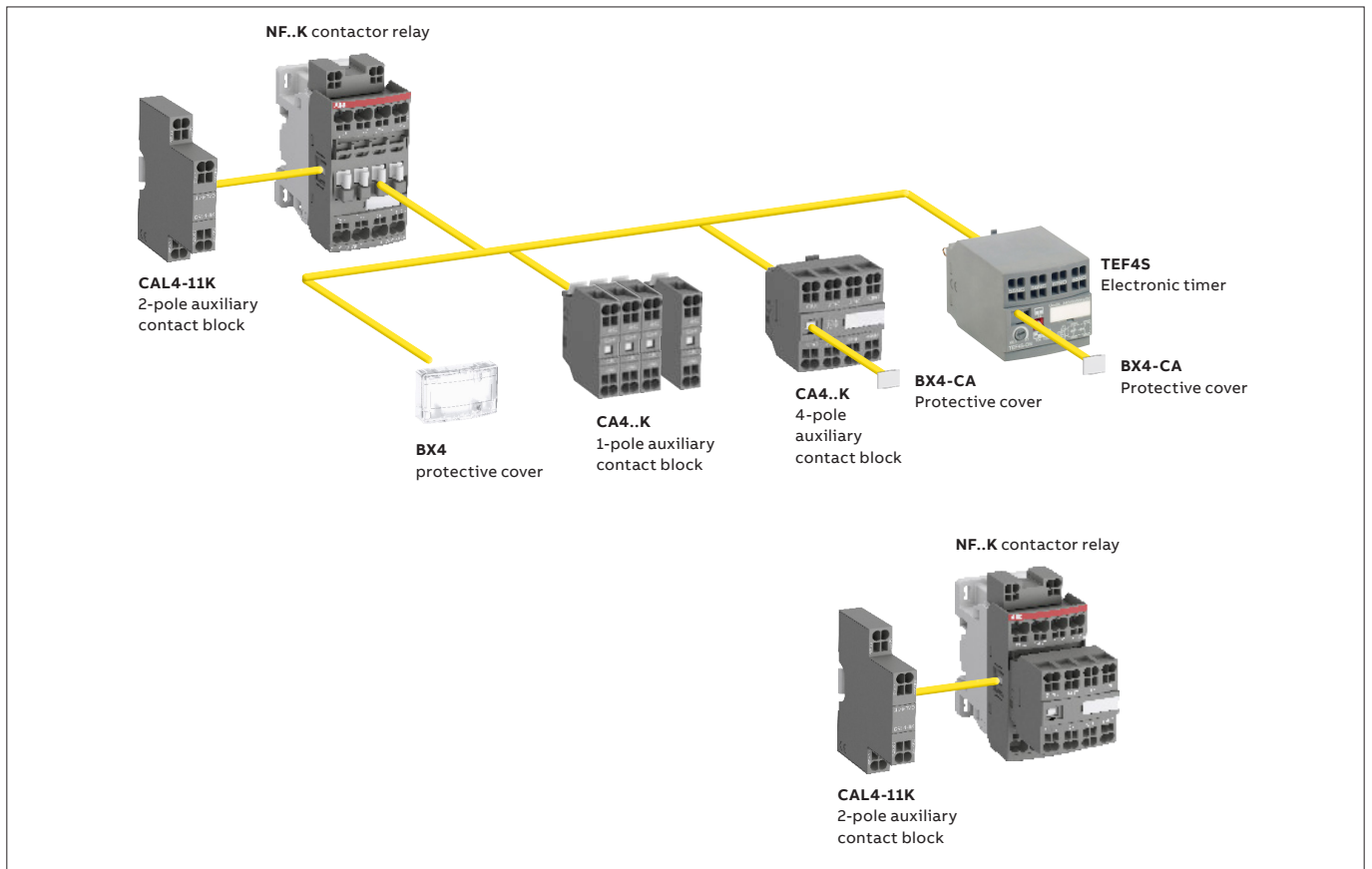

**Main accessory fitting details** - for ordering details, technical data and other accessories: see section accessories  
 Many configurations of accessories are possible depending on whether these are front-mounted or side-mounted.

Contactor relay types	Main poles	Front-mounted accessories			Side-mounted accessories	
		Auxiliary contact blocks		Electronic timer	Auxiliary contact blocks 2-pole CAL4-11K	
		1-pole CA4..K	4-pole CA4..K	TEF4S	Left side	Right side
<b>NF(Z)</b>						
NF	2 2 EK (1)	4 max.	or 1	or 1	+ 1	-
	3 1 EK (1)	2 max.	-	or 1	+ 1	+ 1
	4 0 EK (2)					
NF	4 4 EK	-	-	-	+ 1	-
	5 3 EK					
	6 2 EK					
	7 1 EK					
	8 0 EK					
<b>NFZ 24 V DC designed for PLC - coil 30</b>						
NFZ	2 2 EK (1)	4 max.	or 1	or 1	or 1	+ 1
	3 1 EK (1)	2 max.	-	or 1	+ 1	
	4 0 EK (2)			1	+ 1	+ 1
NFZ	4 4 EK	-	-	-	-	-
	5 3 EK					
	6 2 EK					
	7 1 EK					
	8 0 EK					

(1) Including add-on contacts: 3 N.C. max. on positions 1, 2, 3, 4 and 2 N.C. max. on positions 1 ±30°, 5  
 (2) Including add-on contacts: 4 N.C. max. on positions 1, 2, 3, 4 and 3 N.C. max. on positions 1 ±30°, 5

# NF..K contactor relays - with Push-in Spring terminals

## Main accessories



CA4-10K

1SBC100080V0014

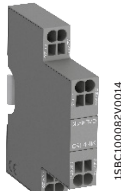

CAL4-11K

1SBC100082V0014



CA4-22NK

1SBC100081V0014



TEF4S-ON

1SBC101394F0014



LDC4K

1SBC100090V0014



BX4

1SBC100021V0014

For contactors	Auxiliary contacts	Type	Order code	Pkg qty	Weight (1 pce)
					kg

### Front-mounted instantaneous auxiliary contact blocks

4-pole NF..K		Type	Order code	Pkg qty	Weight
	1 0	CA4-10K	1SBN010160R1010	1	0.012
	1 0	CA4-10K-T	1SBN010160T1010	10	0.012
	0 1	CA4-01K	1SBN010160R1001	1	0.012
	0 1	CA4-01K-T	1SBN010160T1001	10	0.012
	4 0	CA4-40NK	1SBN010146R1240	1	0.050
	3 1	CA4-31NK	1SBN010146R1231	1	0.050
	2 2	CA4-22NK	1SBN010146R1222	1	0.050
	1 3	CA4-13NK	1SBN010146R1213	1	0.050
NF..40EK	0 4	CA4-04NK	1SBN010146R1204	1	0.050

### Side-mounted instantaneous auxiliary contact blocks

NF..K		Type	Order code	Pkg qty	Weight
	1 1	CAL4-11K	1SBN010134R1011	1	0.030

### Electronic timers

For contactor relays	Time delay range selected by switch	Delay type	Auxiliary contacts	Type	Order code	Pkg qty	Weight (1 pce)
							kg
4-pole NF..K	0.1...1 s	ON-delay	1 1	TEF4S-ON	1SBN020113R1000	1	0.065
	1...10 s	OFF-delay	1 1	TEF4S-OFF	1SBN020115R1000	1	0.065
	10...100 s						

Note: Rated control circuit voltage Uc 24 ... 240 V 50/60 Hz or DC. Terminals with spring mode only.

### Additional coil terminal block

4-pole NF	Type	Order code	Pkg qty	Weight
	LDC4K	1SBN070159T1000	10	0.010

### Protective covers

All 1-stack contactor relays	Type	Order code	Pkg qty	Weight
	BX4	1SBN110108T1000	10	0.006
4-pole CA4 auxiliary contact blocks and TEF4 electronic timer	Type	Order code	Pkg qty	Weight
	BX4-CA	1SBN110109W1000	50	0.001

## NF..K contactor relays - with Push-in Spring terminals

### Technical data

#### Contact utilization characteristics according to IEC

Contactor relay types	AC / DC operated	NF..K
Standards		IEC 60947-1 / 60947-5-1 and EN 60947-1 / 60947-5-1
Rated operational voltage U <sub>e</sub> max.		690 V
Rated frequency (without derating)		50 / 60 Hz
Conventional free air thermal current I <sub>th</sub> - θ ≤ 40 °C		16 A
I <sub>e</sub> / Rated operational current AC-15		
acc. to IEC 60947-5-1	24-127 V 50/60 Hz	6 A
	220-240 V 50/60 Hz	4 A
	400-440 V 50/60 Hz	3 A
	500 V 50/60 Hz	2 A
	690 V 50/60 Hz	2 A
Making capacity AC-15		10 x I <sub>e</sub> AC-15 acc. to IEC 60947-5-1
Breaking capacity AC-15		10 x I <sub>e</sub> AC-15 acc. to IEC 60947-5-1
I <sub>e</sub> / Rated operational current DC-13		
acc. to IEC 60947-5-1	24 V DC	6 A / 144 W
	48 V DC	2.8 A / 134 W
	72 V DC	1 A / 72 W
	110 V DC	0.55 A / 60 W
	125 V DC	0.55 A / 69 W
	220 V DC	0.27 A / 60 W
	250 V DC	0.27 A / 68 W
	400 V DC	0.15 A / 60 W
	500 V DC	0.13 A / 65 W
	600 V DC	0.1 A / 60 W
Short-circuit protection device gG type fuse		10 A
Conditional short-circuit current		1 kA
Rated short-time withstand current I <sub>cw</sub>	for 1.0 s	100 A
	for 0.1 s	140 A
Minimum switching capacity with failure rate acc. to IEC 60947-5-4		12 V / 3 mA
Non-overlapping time between N.O. and N.C. contacts		10 <sup>-7</sup>
Power dissipation per pole at 6 A		≥ 2 ms
Maximum electrical switching frequency	AC-15	0.1 W
	DC-13	1200 cycles/h
Mechanically linked contacts acc. to annex L of IEC 60947-5-1		900 cycles/h
		Built-in N.O. or N.C. auxiliary contacts and additional N.O. or N.C. auxiliary contacts (CA4, CAL4 aux. contact blocks) are mechanically linked contacts

#### Contact utilization characteristics according to UL / CSA

Contactor relay types		NF..K
Standards		UL 508, CSA C22.2 N°14
Maximum operational voltage		600 V AC, 600 V DC
Pilot duty		A600, Q600
AC thermal rated current		10 A
AC maximum volt-ampere making		7200 VA
AC maximum volt-ampere breaking		720 VA
DC thermal rated current		2.5 A
DC maximum volt-ampere making-breaking		69 VA

# NF..K contactor relays - with Push-in Spring terminals

## Technical data

### General technical data

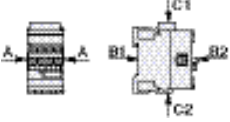
Contactor relay types	AC / DC operated	NF..K
Rated insulation voltage $U_i$ acc. to IEC 60947-5-1 acc. to UL / CSA		690 V 600 V
Rated impulse withstand voltage $U_{imp}$ .		6 kV
Electromagnetic compatibility		Devices complying with IEC 60947-1 / EN 60947-1 - Environment A and B (1)
Ambient air temperature close to contactor relay Operation in free air Storage		-40 ... +70 °C -60 ... +80 °C
Climatic withstand		Category B according to IEC 60947-1 Annex Q
Maximum operating altitude (without derating)		3000 m
Mechanical durability Number of operating cycles Maximum switching frequency		20 million operating cycles 6000 cycles/h
Shock withstand acc. to IEC 60068-2-27 and EN 60068-2-27		
Mounting position 1	Shock direction	1/2 sinusoidal shock for 11 ms: no change in contact position, closed or open position
	A	30 g
	B1	25 g closed position / 5 g open position
	B2	15 g
	C1	25 g
	C2	25 g
Vibration withstand acc. to IEC 60068-2-6		5 ... 300 Hz 4 g closed position / 2 g open position

(1) NF..-12 (48...130 V 50/60 Hz-DC) compliant to environment A only. For environment B: select NFZ..-22.

### Mounting characteristics

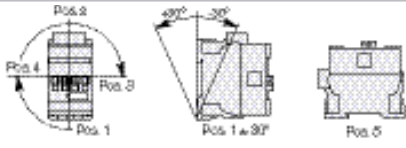
Contactor relay types	AC / DC operated	NF..K
Mounting positions		
Mounting distances		Max. add-on N.C. auxiliary contacts: see accessory fitting details for a NF contactor relay The contactor relays can be assembled side by side
Fixing On rail according to IEC 60715, EN 60715 By screws (not supplied)		35 x 7.5 mm or 35 x 15 mm 2 x M4 screws placed diagonally

### Connecting characteristics

Contactor relay types	AC / DC operated	NF..K
Main terminals		 Push-in Spring terminals
Connection capacity (min. ... max.) Pole and coil terminals		
Rigid	1 x	1 ... 2.5 mm <sup>2</sup>
Rigid	2 x	1 ... 2.5 mm <sup>2</sup>
Flexible with non insulated ferrule	1 x	1 (push-in) / 0.5 (spring) ... 2.5 mm <sup>2</sup>
Flexible with non insulated ferrule	2 x	1 (push-in) / 0.5 (spring) ... 2.5 mm <sup>2</sup>
Flexible with insulated ferrule	1 x	1 (push-in) / 0.5 (spring) ... 1.5 mm <sup>2</sup>
Flexible with insulated ferrule	2 x	1 (push-in) / 0.5 (spring) ... 1.5 mm <sup>2</sup>
Flexible without ferrule	1 x	(spring) 0.5 ... 2.5 mm <sup>2</sup>
Flexible without ferrule	2 x	(spring) 0.5 ... 2.5 mm <sup>2</sup>
Connection capacity acc. to UL/CSA	1 or 2 x	AWG 18 ... 14
Stripping length		10 mm
Degree of protection acc. to IEC 60947-1 / EN 60947-1 and IEC 60529 / EN 60529		IP20
Screwdriver type	All terminals	Flat Ø 3 mm x 0.5 mm

## NF..K contactor relays - with Push-in Spring terminals

### Technical data

#### Magnet System Characteristics for NF..K contactor relays - AC / DC operated

Contactor relay types	AC / DC operated	NF..K
Coil operating limits acc. to IEC 60947-5-1	AC supply	at $\theta \leq 60^\circ\text{C}$ $0.85 \times U_c \text{ min} \dots 1.1 \times U_c \text{ max}$ at $\theta \leq 70^\circ\text{C}$ $0.85 \times U_c \text{ min} \dots U_c \text{ max}$
	DC supply	At $\theta \leq 60^\circ\text{C}$ $0.85 \times U_c \text{ min} \dots 1.1 \times U_c \text{ max}$ At $\theta \leq 70^\circ\text{C}$ $0.85 \times U_c \text{ min} \dots U_c \text{ max}$
AC control voltage 50/60 Hz		
Rated control circuit voltage $U_c$		24 ... 500 V AC
Coil consumption	Average pull-in value	50 VA
	Average holding value	2.2 VA / 2 W
DC control voltage		
Rated control circuit voltage $U_c$		20 ... 500 V DC
Coil consumption	Average pull-in value	50 W
	Average holding value	2 W
PLC-output control		Not suitable for direct control by PLC-output
Drop-out voltage		$\leq 60\%$ of $U_c \text{ min.}$
Voltage sag immunity according to SEMI F47-0706		-
Dips withstand $-20^\circ\text{C} \leq \theta \leq +60^\circ\text{C}$		-
Operating time		
Between coil energization and:		
N.O. contact closing		40 ... 95 ms
N.C. contact opening		38 ... 90 ms
Between coil de-energization and:		
N.O. contact opening		11 ... 95 ms
N.C. contact closing		13 ... 98 ms

#### Magnet System Characteristics for NFZ..K contactor relays 24V DC operated - designed for PLC - coil 30

Contactor relay types	AC / DC operated	NFZ..K
Coil operating limits acc. to IEC 60947-5-1	DC supply	At $\theta \leq 60^\circ\text{C}$ $0.85 \dots 1.1 \times U_c$ At $\theta \leq 70^\circ\text{C}$ $U_c$
DC control voltage		
Rated control circuit voltage $U_c$		24 V DC
Coil consumption	Average pull-in value	6 W
	Average holding value	1.7 W
PLC-output control		$\geq 250 \text{ mA}$ 24 V DC for PLCs and safety PLCs using broken wire detection
Drop-out voltage		$\leq 60\%$ of $U_c \text{ min.}$
Operating time		
Between coil energization and:		
N.O. contact closing		27 ... 53 ms
N.C. contact opening		20 ... 35 ms
Between coil de-energization and:		
N.O. contact opening		17 ... 29 ms
N.C. contact closing		22 ... 57 ms

#### Magnet System Characteristics for NFZ..K contactor relays - for specific applications - coils 20, 21, 22, 23

Contactor relay types	AC / DC operated	NFZ..K
Coil operating limits acc. to IEC 60947-5-1	AC supply	At $\theta \leq 60^\circ\text{C}$ $0.85 \times U_c \text{ min} \dots 1.1 \times U_c \text{ max}$ At $\theta \leq 70^\circ\text{C}$ $0.85 \times U_c \text{ min} \dots U_c \text{ max}$
	DC supply	At $\theta \leq 70^\circ\text{C}$ $0.85 \times U_c \text{ min} \dots 1.1 \times U_c \text{ max}$
AC control voltage 50/60 Hz		
Rated control circuit voltage $U_c$		24 ... 250 V AC
Coil consumption	Average pull-in value	16 VA
	Average holding value	1.7 VA / 1.5 W
DC control voltage		
Rated control circuit voltage $U_c$		12 ... 250 V DC
Coil consumption	Average pull-in value	12 ... 16 W
	Average holding value	1.7 W
PLC-output control		(AF..Z coil 21) $\geq 500 \text{ mA}$ 24 V DC for PLCs - Not suitable for safety PLCs
Drop-out voltage		$\leq 60\%$ of $U_c \text{ min.}$
Voltage sag immunity according to SEMI F47-0706		(NFZ coil 21, 22, 23) conditions of use on request
Dips withstand $-20^\circ\text{C} \leq \theta \leq +60^\circ\text{C}$		(NFZ coil 21, 22, 23) 20 ms average for $U_c \geq 24 \text{ V}$ 50/60 Hz or $U_c \geq 20 \text{ V}$ DC
Operating time		
Between coil energization and:		
N.O. contact closing		40 ... 95 ms
N.C. contact opening		38 ... 90 ms
Between coil de-energization and:		
N.O. contact opening		11 ... 95 ms
N.C. contact closing		13 ... 98 ms

# NF..K contactor relays - with Push-in Spring terminals

## Terminal marking and positioning

### Standard devices without addition of auxiliary contacts

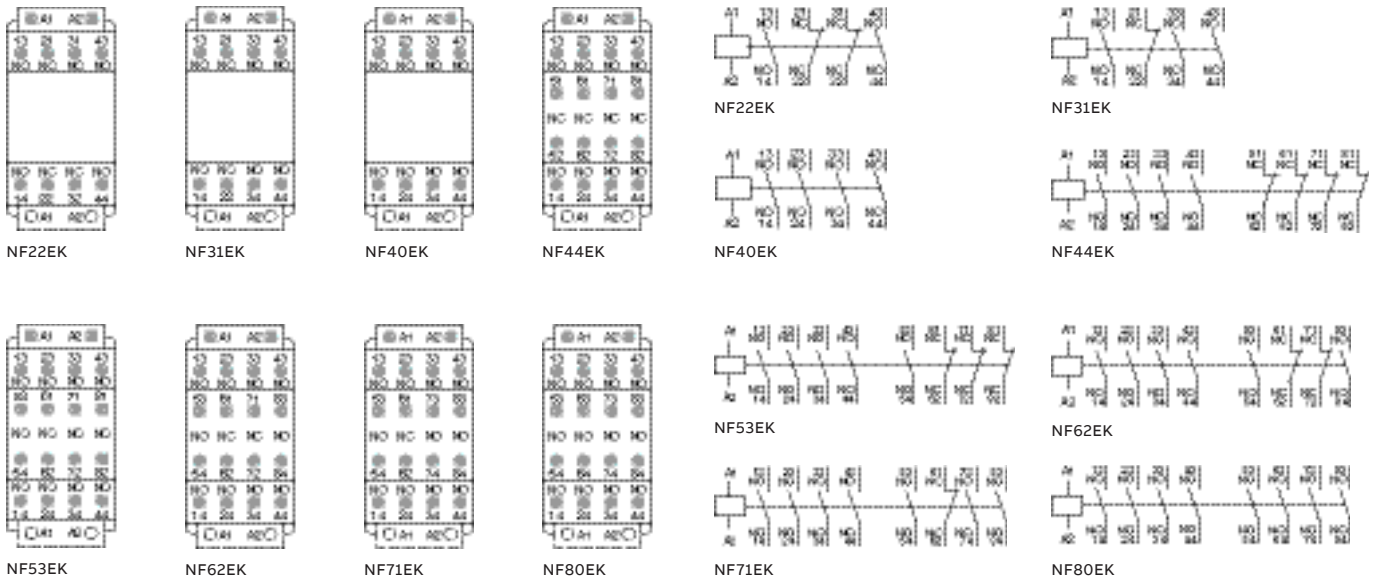

### Other possible contact combinations with auxiliary contacts added by the user

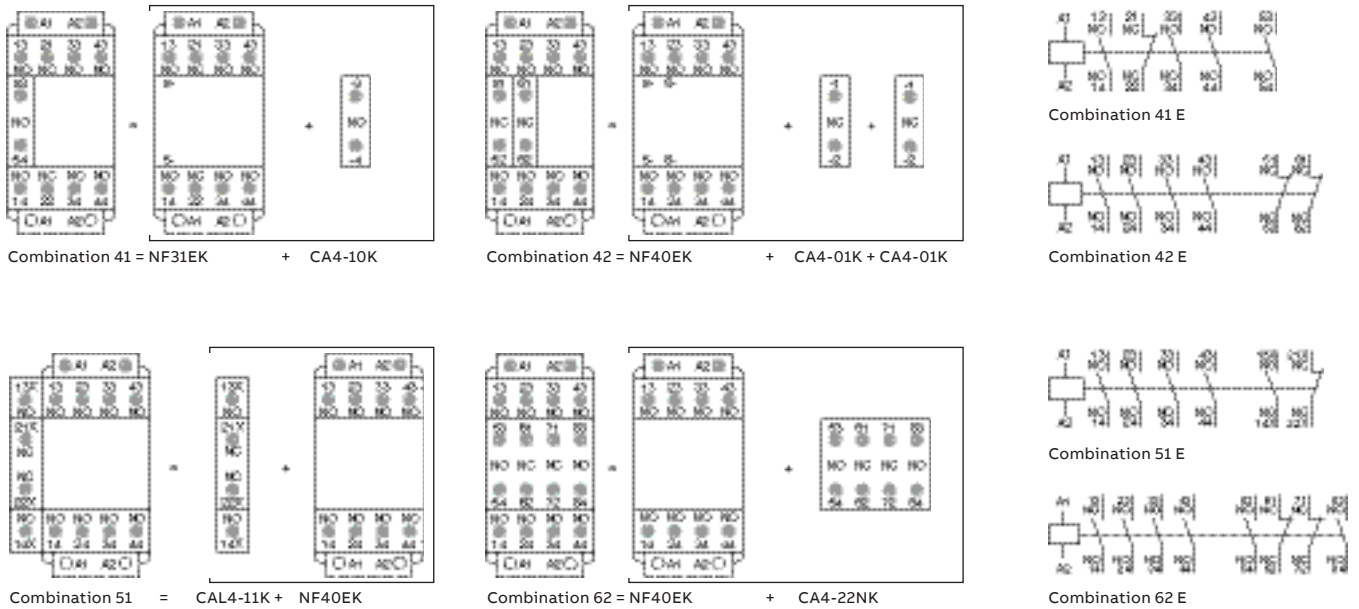

Note: Only NFZ contactor relays with DC control voltage 12...20 V DC need to respect the connection polarities indicated close to the coil terminals: A1+ for the positive pole and A2- for the negative pole.

# NF.K add-on auxiliary contacts - with Push-in Spring terminals

## Terminal marking and positioning

### 1-pole auxiliary contacts

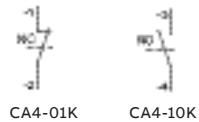

### 2-pole auxiliary contacts

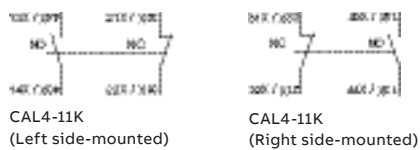

### 4-pole auxiliary contacts

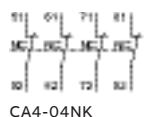
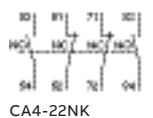
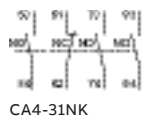
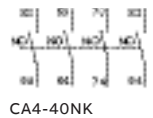

# NF..K contactor relays - with Push-in Spring terminals

## Dimensions

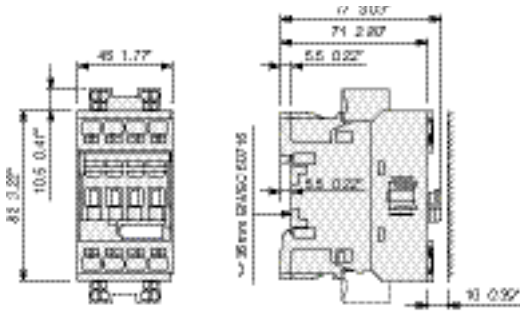

NF22EK, NF31EK, NF40EK

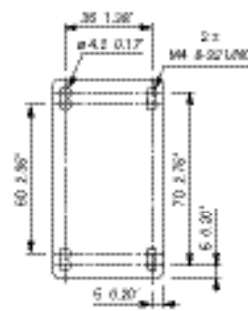

NF22EK, NF31EK, NF40EK

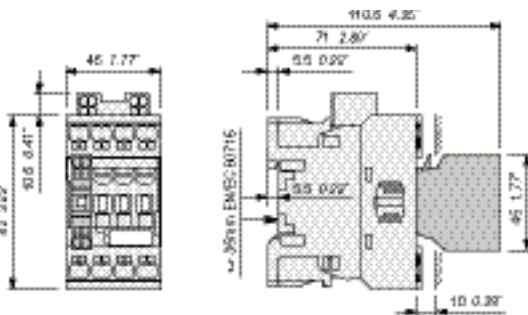

NF22EK, NF31EK, NF40EK  
+ CA4..K 1-pole auxiliary contact block

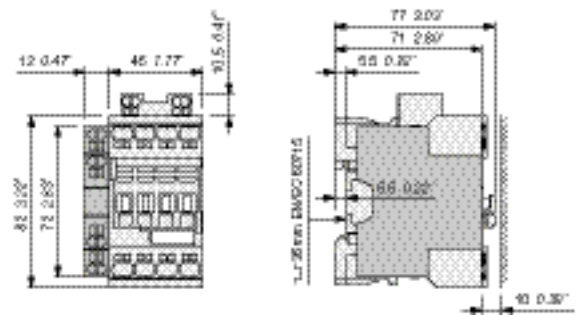

NF22EK, NF31EK, NF40EK  
+ CAL4-11K 2-pole auxiliary contact block

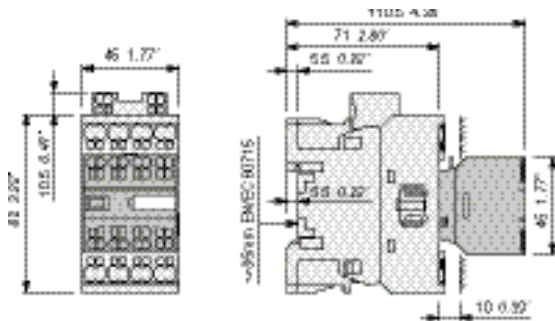

NF22EK, NF31EK, NF40EK  
+ CA4..K 4-pole auxiliary contact block

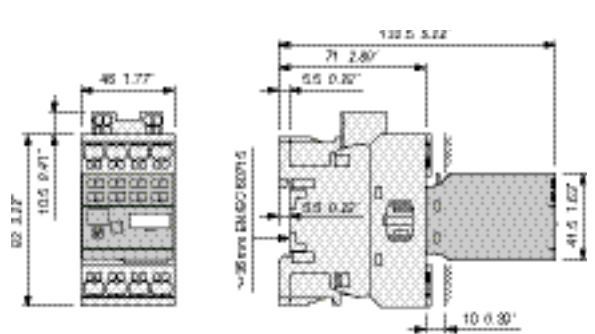

NF22EK, NF31EK, NF40EK  
+ TEF4S electronic timer

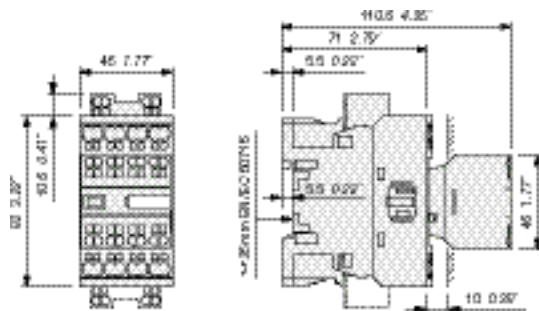

NF44EK, NF53EK, NF62EK, NF71EK, NF80EK

Note: contactor relay lateral distance to grounded component 2 mm 0.08" min.  
24 V DC operated contactor (coil 30) depth + 20 mm (0.79").

Main dimensions mm, inches



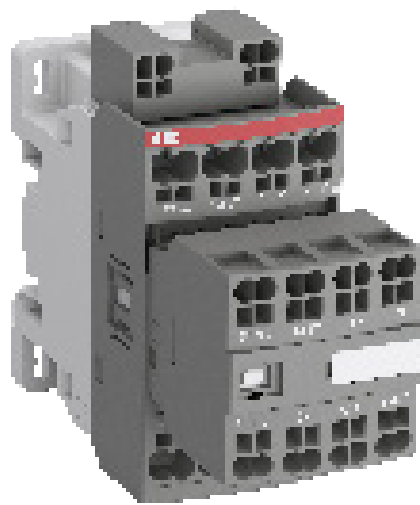

---

# Accessories

<b>65</b>	<b>Auxiliary contact blocks with Push-in Spring terminals</b>
<b>66</b>	<b>Technical data</b>
<b>67</b>	<b>Electrical durability</b>
<b>68</b>	<b>Terminal marking and positioning</b>
<b>69</b>	<b>Electronic timers - with spring terminals</b>
<b>72</b>	<b>Interlocks</b>
<b>73</b>	<b>Other accessories</b>
<b>74</b>	<b>Connection accessories for starting solutions</b>

## Auxiliary contact blocks with Push-in Spring terminals



CA4-10K

1SBCL00080V0004



CA4-22EK

1SBCL00081V0004



CAL4-11K

1SBCL00082V0004

The auxiliary contact blocks are used for the operation of auxiliary circuits and control circuits for standard industrial environments.

Types of auxiliary contact blocks for front mounting:

- CA4..K 1 or 4-pole block, with instantaneous N.O., N.C. contacts

Select the 4-pole auxiliary contact blocks CA4-..EK, CA4-..MK or CA4-..NK type, according to the contactor or contactor relay type for compliance with the standard requirements (see "Terminal marking and positioning").

Types of auxiliary contact blocks for side mounting:

- CAL4..K 2-pole block, with instantaneous N.O. + N.C. contacts.

For clipping onto the right- and/or left-hand side of the contactors.

The auxiliary contact blocks are equipped with push-in spring terminals protected against accidental direct contact and bear the corresponding function marking.

For contactors	Auxiliary contacts	Type	Order code	Pkg qty	Weight (1 pce)
					kg

### front-mounted instantaneous auxiliary contact blocks

AF09..K ... AF38..K	1 0	CA4-10K	1SBN010160R1010	1	0.012
NF..K	1 0	CA4-10K-T	1SBN010160T1010	10	0.012
	0 1	CA4-01K	1SBN010160R1001	1	0.012
	0 1	CA4-01K-T	1SBN010160T1001	10	0.012
AF09 ... AF16..-30-10K	2 2	CA4-22MK	1SBN010146R1122	1	0.050
	3 1	CA4-31MK	1SBN010146R1131	1	0.050
	1 3	CA4-13MK	1SBN010146R1113	1	0.050
	0 4	CA4-04MK	1SBN010146R1104	1	0.050
AF26 ... AF38..-30-00K	2 2	CA4-22EK	1SBN010146R1022	1	0.050
AF09 ... AF16..-40-00K	3 1	CA4-31EK	1SBN010146R1031	1	0.050
AF09 ... AF16..-22-00K	4 0	CA4-40EK	1SBN010146R1040	1	0.050
4-pole NF..K	1 3	CA4-13NK	1SBN010146R1213	1	0.050
	2 2	CA4-22NK	1SBN010146R1222	1	0.050
	3 1	CA4-31NK	1SBN010146R1231	1	0.050
	4 0	CA4-40NK	1SBN010146R1240	1	0.050
NF(Z)40EK	0 4	CA4-04NK	1SBN010146R1204	1	0.050

### Side-mounted instantaneous auxiliary contact blocks

#### 3-pole

AF09..K ... AF38..K	1 1	CAL4-11K	1SBN010134R1011	1	0.030
NF...K					

Note: for each contactor or contactor relay type, refer to "Accessory fitting details" table.

## Auxiliary contact blocks for AF09 ... AF96 contactors and NF contactor relays with Push-in Spring terminals

### Technical data









#### Contact utilization characteristics according to IEC

Contactor relay types		1-pole CA4..K, 4-pole CA4..K, 2-pole CAL4..K
Standards		IEC 60947-1 / 60947-4-1 and EN 60947-1 / 60947-4-1
Rated insulation voltage $U_i$ acc. to IEC 60947-5-1		690 V
Rated impulse withstand voltage $U_{imp}$ .		6 kV
Rated operational voltage $U_e$ max.		690 V
Conventional thermal current $I_{th} - \theta \leq 40^\circ\text{C}$		16 A
Rated frequency (without derating)		50 / 60 Hz
le / Rated operational current AC-15 acc. to IEC 60947-5-1		24-127 V 50/60 Hz 6 A 220-240 V 50/60 Hz 4 A 400-440 V 50/60 Hz 3 A 500 V 50/60 Hz 2 A 690 V 50/60 Hz 2 A
Making capacity acc. to IEC 60947-5-1		10 x $I_e$ AC-15
Breaking capacity acc. to IEC 60947-5-1		10 x $I_e$ AC-15
le / Rated operational current DC-13 acc. to IEC 60947-5-1		24 V DC 6 A / 144 W 48 V DC 2.8 A / 134 W 72 V DC 1 A / 72 W 110 V DC 0.55 A / 60 W 125 V DC 0.55 A / 69 W 220 V DC 0.27 A / 60 W 250 V DC 0.27 A / 68 W 400 V DC 0.15 A / 60 W 500 V DC 0.13 A / 65 W 600 V DC 0.1 A / 60 W
Short-circuit protection device gG type fuse		10 A
Conditional short-circuit current		1 kA
Rated short-time withstand current $I_{cw}$ $\theta = 40^\circ\text{C}$		for 1.0 s 100 A for 0.1 s 140 A
Minimum switching capacity with failure rate acc. to IEC 60947-5-4		12 V / 3 mA $10^{-7}$
Power dissipation per pole at 6 A		0.1 W
Mechanical durability		Number of operating cycles 10 million operating cycles Max. switching frequency 3600 cycles/h
Max. electrical switching frequency		AC-15 1200 cycles/h DC-13 900 cycles/h
Mechanically linked contacts acc. to annex L of IEC 60947-5-1		Additional N.O. or N.C. auxiliary contacts (CA4, CAL4) are mechanically linked contacts.
Mirror contacts acc. to annex F of IEC 60947-4-1		Additional N.C. auxiliary contacts (CA4, CAL4) are mirror contacts.

#### Contact utilization characteristics according to UL / CSA

Standards		UL 508, CSA C22 N°14
Max. operational voltage		600 V AC, 600 V DC
Pilot duty		A600, Q600
AC thermal rated current		10 A
AC maximum volt-ampere making		7200 VA
AC maximum volt-ampere breaking		720 VA
DC thermal rated current		2.5 A
DC maximum volt-ampere making-breaking		69 VA

#### Connecting characteristics

Connection capacity (min. ... max.)		
 Rigid solid	1 x	1 ... 2.5 mm <sup>2</sup>
 Rigid solid	2 x	1 ... 2.5 mm <sup>2</sup>
 Flexible with ferrule	1 x	1 (push-in) / 0.5 (spring) ... 2.5 mm <sup>2</sup>
 Flexible with ferrule	2 x	1 (push-in) / 0.5 (spring) ... 2.5 mm <sup>2</sup>
 Flexible with insulated ferrule	1 x	1 (push-in) / 0.5 (spring) ... 1.5 mm <sup>2</sup>
 Flexible with insulated ferrule	2 x	1 (push-in) / 0.5 (spring) ... 1.5 mm <sup>2</sup>
 Flexible without ferrule	1 x	(spring) 0.5 ... 2.5 mm <sup>2</sup>
 Flexible without ferrule	2 x	(spring) 0.5 ... 2.5 mm <sup>2</sup>
Connection capacity acc. to UL/CSA		1 or 2 x AWG 18 ... 14
Stripping length		10 mm
Degree of protection acc. to IEC 60947-1 / EN 60947-1 and IEC 60529 / EN 60529		IP20
Screwdriver type		Flat $\varnothing$ 3 mm x 0.5 mm

# Auxiliary contact blocks for AF09 ... AF96 contactors and NF contactor relays with Push-in Spring terminals

## Electrical durability

### Electrical durability for AC-15 utilization category

AC-15 utilization category according to IEC 60947-5-1 / EN 60947-5-1:

- making current:  $10 \times I_e$  with  $\cos \phi = 0.7$  and  $U_e$
- breaking current:  $I_e$  with  $\cos \phi = 0.4$  and  $U_e$ .

These curves represent the electrical durability of the built-in or add-on auxiliary contacts in relation to the breaking current. The curves have been drawn for resistive and inductive loads up to 690 V, 40...60 Hz.

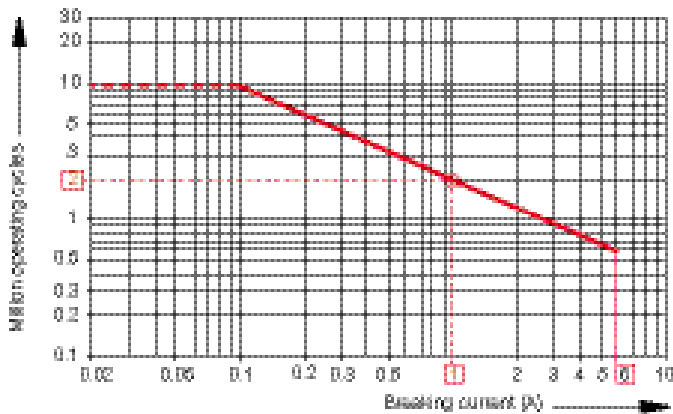

- AF09 ... AF38 contactor built-in auxiliary contacts
- 1-pole and 4-pole CA4, 2-pole CAT4,
- 1-pole CC4, 2-pole CAL4 add-on auxiliary contacts.

**Example:**

Breaking current = 1 A  
 On the opposite curve at intersection "O" 1 A the corresponding value for the electrical durability is approximately 2 millions operating cycles.

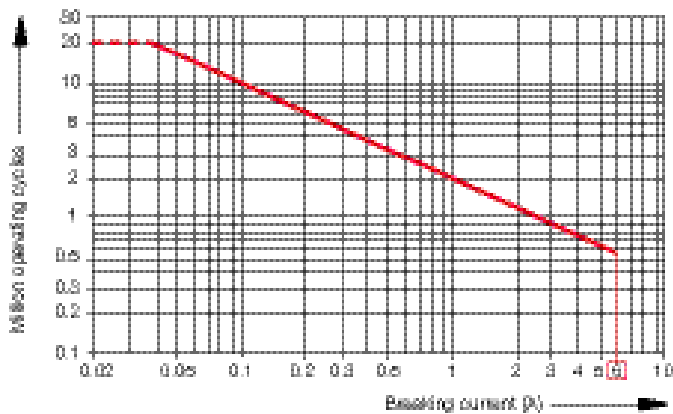

NF contactor relays.  
 (For add on auxiliary contacts see curve above).

### Electrical durability for DC-13 utilization category

DC-13 utilization category according to IEC 60947-5-1 / EN 60947-5-1: making and breaking current  $I_e$  and  $U_e$ .

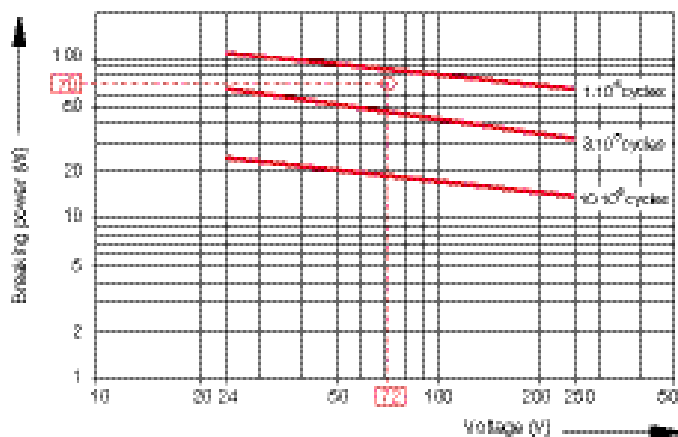

- AF09 ... AF38 contactor built-in auxiliary contacts
- 1-pole and 4-pole CA4, 2-pole CAT4, 1-pole CC4,
- 2-pole CAL4 add-on auxiliary contacts,
- NF contactor relays.

**Example:**

Control of DC electro-magnet:  
 $U_e$  voltage = 72 V DC and breaking power = 70 W.  
 On the opposite curve at intersection "O" 72 V / 70 W the corresponding value for the electrical durability is approximately 2 millions operating cycles.

# Add-on auxiliary contacts - with Push-in Spring terminals

## Terminal marking and positioning

### 1-pole auxiliary contacts



CA4-01K



CA4-10K

### 2-pole auxiliary contacts

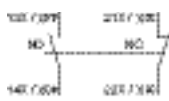

CA4-11K  
(Left-side mounted)



CA4-11K  
(Right-side mounted)

### 4-pole auxiliary contacts

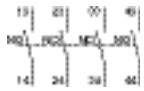

CA4-40EK

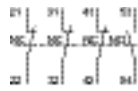

CA4-13MK



CA4-13NK

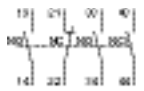

CA4-31EK



CA4-31MK

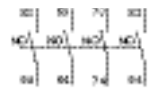

CA4-40NK

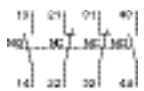

CA4-22EK

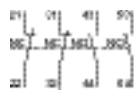

CA4-22MK



CA4-31NK



CA4-04MK

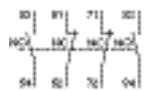

CA4-22NK

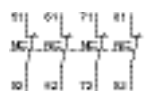

CA4-04NK

## Electronic timers - with spring terminals

TEF4S frontal electronic timers are used for realizing timing function and are available in ON-delay and OFF-delay versions.

### Compact solution in cabinet compared to separate timers

TEF4S electronic timers are front-mounted and locked on AF..K..S contactors or NF..K..S contactor relays. A mechanical indicator allows to show the state of the contactor.

### Safe and cost-reduced wiring

TEF4S electronic timers are supplied by a direct plug-in parallel connection to the coil terminals A1 - A2 of the contactor or contactor relay. A varistor is integrated on the timer to offer a built-in protection against surges in the contactor coil.

### Available for a wide control voltage range 24 ... 240 V AC / DC

TEF4S-ON or TEF4S-OFF allow time-delayed functions up to 100 s in 3 distinct time ranges, independently of the control system. The time delay ranges are selected by a switch and the time delay can be adjusted by means of a rotary switch. The timing function is activated by closing or opening the device on which the timer is mounted. The OFF-delay version operates without additional control supply.



TEF4S-ON

15BC10139AF0014



TEF4S-OFF



15BC10139F0014

For contactors, contactor relays	Time delay range selected by switch	Delay type	Rated control circuit voltage U <sub>c</sub> V 50/60 Hz or DC	Auxiliary contacts	Type	Order code	Weight Pkg (1 pce) kg
AF09 ... AF96 NF	0.1...1 s	ON-delay	24...240	1 1	TEF4S-ON	15BN020113R1000	0.065
	1...10 s 10...100 s	OFF-delay	24...240	1 1	TEF4S-OFF	15BN020115R1000	0.065

## Electronic timers - with spring terminals

### Technical data

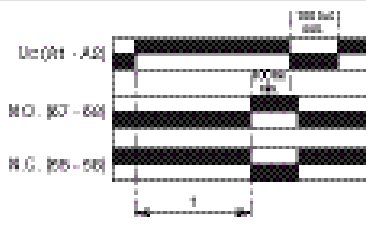
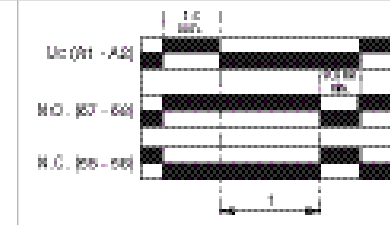
#### Contact utilization characteristics according to IEC

Types	TEF4S-ON	TEF4S-OFF
Standards	IEC 60947-5-1 and EN 60947-5-1	
Rated insulation voltage $U_i$ acc. to IEC 60947-5-1	400 V	
Rated impulse withstand voltage $U_{imp}$	4 kV	
Rated operational voltage $U_e$ max.	240 V	
Rated frequency (without derating)	50 / 60 Hz	
Conventional thermal current $I_{th} - \theta \leq 40^\circ\text{C}$	5 A	
$I_e$ / Rated operational current AC-15 acc. to IEC 60947-5-1	24-127 V 50/60 Hz 3 A	220-240 V 50/60 Hz 1.5 A
Making capacity acc. to IEC 60947-5-1	10 x $I_e$ AC-15	
Breaking capacity acc. to IEC 60947-5-1	10 x $I_e$ AC-15	
$I_e$ / Rated operational current DC-13 acc. to IEC 60947-5-1	24 V DC 1 A / 24 W	
Short-circuit protection device gG type fuse	6 A	
Rated short-time withstand current $I_{cw}$ $\theta = 40^\circ\text{C}$	for 1.0 s 8 A	for 0.1 s 8 A
Minimum switching capacity with failure rate acc. to IEC 60947-5-4	24 V DC 12 V / 3 mA 10-7	
Power dissipation per pole at 3 A	0.1 W	
Function diagram	ON-delay 	OFF-delay 
Bistable relay inside. Before use, once apply $U_c$ then switch it off in order to initialize position of the contacts.		
Control circuit voltage	24...240 V AC	
AC control voltage	Rated control circuit voltage $U_c$	24...240 V AC
50/60 Hz	Average consumption	1.5 mA RMS
DC control voltage	Rated control circuit voltage $U_c$	24...240 V DC
	Average consumption	1.5 mA
Rated frequency limits	50 / 60 Hz	
Supply voltage range	0.85...1.1 x $U_c$ (at $\theta \leq 70^\circ\text{C}$ )	
Overvoltage protection	Varistor included	
Time delay range (t) selected by switch	0.1...1 s 1...10 s 10...100 s	
On-load reiteration accuracy under constant conditions	$\leq 1\%$	
Minimum ON period	0.1 s	1 s
Recovery time	0.15 s	0.1 s
Ambient air temperature	Operation	-25 °C ... +70 °C
	Storage	-40 °C ... +80 °C
Climatic withstand	Category B according to IEC 60947-1 Annex Q	
Maximum operating altitude	2000 m	
Mounting positions	Mounting positions 1, 1 +/- 30°, 2, 3, 4, 5	
Shock withstand acc. to IEC 60068-2-27 and EN 60068-2-27 (Mounting position 1)	1/2 sinusoidal shock for 11 ms: no change in contact position Same as contactor or contactor relay	
Vibration withstand acc. to IEC 60068-2-6	5...300 Hz 3 g closed position / 2 g open position	
Mechanical durability	Number of operating cycles	5 millions operating cycles
	Max. switching frequency	3600 cycles/h
Max. electrical switching frequency	AC-15	1200 cycles/h
	DC-13	900 cycles/h





# Electronic timers - with spring terminals

## Technical data

### Contact utilization characteristics according to UL / CSA

Types	TEF4S-ON	TEF4S-OFF
AC thermal rated current	5 A	
AC maximum volt-ampere making	3600 VA	
AC maximum volt-ampere breaking	360 VA	
DC thermal rated current	1 A	
DC maximum volt-ampere making-breaking	28 VA	

### Connecting characteristics

Connection capacity (min. ... max.)		
 Rigid solid	1 x	1...2.5 mm <sup>2</sup>
	2 x	1...2.5 mm <sup>2</sup>
 Flexible with non insulated ferrule	1 x	0.75...2.5 mm <sup>2</sup>
	2 x	0.75...2.5 mm <sup>2</sup>
 Flexible with insulated ferrule	1 x	0.75...1.5 mm <sup>2</sup>
	2 x	0.75...1.5 mm <sup>2</sup>
Connection capacity acc. to UL / CSA	1 or 2 x	AWG 18...14
Stripping length		10 mm
Degree of protection		IP20
acc. to IEC 60947-1 / EN 60947-1 and IEC 60529 / EN 60529		
Screwdriver type		Flat Ø 3.5
Terminal Marking		

## Interlocks

### Accessories for AF09..K ... AF38..K 3-pole contactors



VM4

1SBC100010V0014



VEM4K

1SBC100083V0014

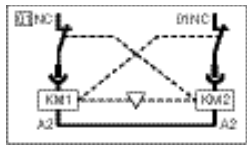

BB4

1SBC100013V0014

#### Mechanical interlock unit

VM4 mechanical interlock unit is designed for the interlocking of two AF contactors.

When mounted between two contactors, the VM4 mechanical interlock unit prevents one of the contactors from closing as long as the other contactor is closed. The mechanical interlock unit VM4 includes 2 fixing clips (BB4).

For contactors	Type	Order code	Pkg qty	Weight (1 pce) kg
AF09 ... AF38	VM4	1SBN030105T1000	10	0.005

#### Mechanical and electrical interlock set (1)

VEM4K mechanical and electrical interlock set for the interlocking of two AF..K contactors.

VEM4K set includes a mechanical interlock unit VM4 with 2 fixing clips (BB4) and a VE4K electrical interlock block with A2-A2 connection.

Fixing the electrical interlock block to the contactor front face connects the 2 built-in N.C. interlocking contacts with the two coils.

VE4K block must be used with A2-A2 connection to respect the electrical connection

For contactors	Auxiliary contacts	Type	Order code	Pkg qty	Weight (1 pce) kg
AF09..K .. AF16..K AF26..K .. AF38..K	1 1	VEM4K	-		0.030

#### Fixing clips

For contactors	Type	Order code	Pkg qty	Weight (1 pce) kg
AF09 ... AF96	BB4	1SBN110120W1000	50	0.002

Note: VEM4K not suitable for AFZ contactors with DC control voltage 12...20 V DC.

(1) For more information, please consult your ABB local sales organization

#### Mechanical interlock unit

Types		VM4
Mechanical durability	Number of operating cycles	5 million operating cycles
	Max. mechanical switching frequency	1800 cycles/h

## Other accessories

Accessories for AF09..K ... AF38..K contactors and NF..K contactor relays

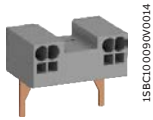

LDC4K

### Additional coil terminal block

Additional coil terminal block for a bottom access to the coil terminals of contactors or contactor relays.

For contactors	Type	Order code	Pkg qty	Weight (1 pce) kg
AF09 ... AF96, NF	LDC4K	1SBN070159T1000	10	0.010



BX4

### Protective covers

Sealable and transparent protective covers BX4 and non-removable BX4-CA to protect the devices against accidental contact.

AF09 ... AF96 1-stack contactors and NF contactor relays	BX4	1SBN110108T1000	10	0.006
4-pole CA4, 2-pole CAT4 auxiliary contact blocks and TEF4 electronic timer	BX4-CA	1SBN110109W1000	50	0.001

Note: BX4 produced since 13045 (day 045 - year 2013) are suitable for AF40 ... AF96.



BX4-CA



BA4

### Function markers AF09..K ... AF38..K

Box of 16 blank cards (16 markers by card) printable on HTP500 thermal transfer printer and AMS 500 marking table to identify your contactors, overload relays or manual motor starters. Marker dimensions: 7 x 20 mm (.276" x .787").

AF09 ... AF370 contactors, TF thermal overload relays, EF electronic overload relays and MS116, MS132, MS165 manual motor starters	BA4	1SNA235156R2700	16	0.011
AMS 500 support plate for 8 BA4	SPRC 1	1SNA360010R1500	1	0.220
HTP500 support plate	HTP500-BA4	1SNA235712R2400	1	0.290



BA5-50



BX4

Dimensions mm, inches

## Connection accessories for starting solutions with Push-in Spring terminals



BEA16-4KF

1SBCL01673V0014

### Connecting links with manual motor starters

The BEA...-4KF insulated 3-pole connecting links are used to connect AF09..K ... AF38..K contactors with the MS132-K manual motor starters. The BEA...-4KF insulated 3-pole connecting links ensure the electrical and mechanical connection between the contactor and the associated manual motor starter.

For 3-pole contactors	Manual motor starter	Type	Order code	Pkg qty	Weight (1 pce) kg
AF09..K ... AF16..K	MS132-0.16 ... MS132-25	BEA16-4KF	1SBN081325T1000	10	0.052
AF26..K ... AF38..K	MS132-0.16 ... MS132-32	BEA38-4KF	1SBN082325T2000	10	0.057

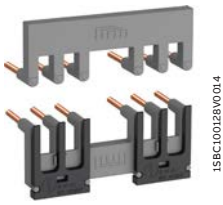

BER16-4KF

1SBCL00128V0014

### Connection sets for reversing contactors

AF09..K ... AF16..K	BER16-4KF	1SBN081322R1000	1	0.050
AF26..K ... AF38..K	BER38-4KF	1SBN082322R1000	1	0.080

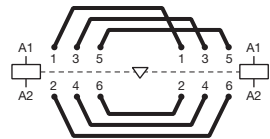

BER  
Reversing connections

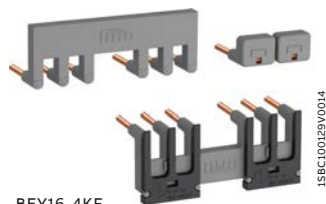

BEY16-4KF

1SBCL00129V0014

### Connection sets for star-delta starter

AF09..K ... AF16..K	BEY16-4KF	1SBN081323R2000	1	0.055
AF26..K ... AF38..K	BEY38-4KF	1SBN082323R2000	1	0.090

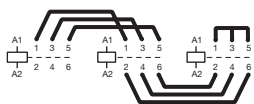

BEY  
Line-delta-star connection

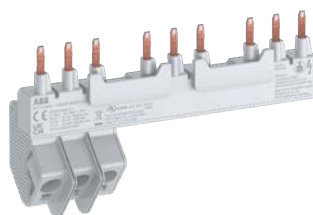

PS 1-3-1-65K busbar  
with Push-in Spring terminals

### Busbars with Push-in Spring terminals

Suitable for	Rated operational current A	No. of manual motor starter	Number of lateral auxiliary contacts	Type	Order code	Pkg qty	Weight (1 pce) kg
MS132K, MS132-KT	65	2	0	PS1-2-0-65K	1SAM301903R1002	1	0.091
	65	3	0	PS1-3-0-65K	1SAM301903R1003	1	0.116
	65	4	0	PS1-4-0-65K	1SAM301903R1004	1	0.140
	65	5	0	PS1-5-0-65K	1SAM301903R1005	1	0.165
	65	2	1	PS1-2-1-65K	1SAM301903R1012	1	0.094
	65	3	1	PS1-3-1-65K	1SAM301903R1013	1	0.123
	65	4	1	PS1-4-1-65K	1SAM301903R1014	1	0.151
	65	5	1	PS1-5-1-65K	1SAM301903R1015	1	0.178

# Motor rated operational powers and currents

The currents given below concern standard three-phase four-pole cage motors (1500 r.p.m. at 50 Hz 1800 r.p.m. at 60 Hz). These values are given for guidance and may vary according to the motor manufacturer and depending on the number of poles.

IEC Motor nominal current: standardized values in grey (according to IEC 60947-4-1 Annex G)										
Motor power	220 V	230 V	240 V	380 V	400 V	415 V	440 V	500 V	660 V	690 V
kW	A	A	A	A	A	A	A	A	A	A
0.06	0.37	0.35	0.34	0.21	0.2	0.19	0.18	0.16	0.13	0.12
0.09	0.54	0.52	0.50	0.32	0.3	0.29	0.26	0.24	0.18	0.17
0.12	0.73	0.7	0.67	0.46	0.44	0.42	0.39	0.32	0.24	0.23
0.18	1	1	1	0.63	0.6	0.58	0.53	0.48	0.37	0.35
0.25	1.6	1.5	1.4	0.9	0.85	0.82	0.74	0.68	0.51	0.49
0.37	2.0	1.9	1.8	1.2	1.1	1.1	1	0.88	0.67	0.64
0.55	2.7	2.6	2.5	1.6	1.5	1.4	1.3	1.2	0.91	0.87
0.75	3.5	3.3	3.2	2.0	1.9	1.8	1.7	1.5	1.15	1.1
1.1	4.9	4.7	4.5	2.8	2.7	2.6	2.4	2.2	1.7	1.6
1.5	6.6	6.3	6	3.8	3.6	3.5	3.2	2.9	2.2	2.1
2.2	8.9	8.5	8.1	5.2	4.9	4.7	4.3	3.9	2.9	2.8
3	11.8	11.3	10.8	6.8	6.5	6.3	5.7	5.2	4	3.8
4	15.7	15	14.4	8.9	8.5	8.2	7.4	6.8	5.1	4.9
5.5	20.9	20	19.2	12.1	11.5	11.1	10.1	9.2	7	6.7
7.5	28.2	27	25.9	16.3	15.5	14.9	13.6	12.4	9.3	8.9
11	39.7	38	36.4	23.2	22	21.2	19.3	17.6	13.4	12.8
15	53.3	51	48.9	30.5	29	28	25.4	23	17.8	17
18.5	63.8	61	58.5	36.8	35	33.7	30.7	28	22	21
22	75.3	72	69	43.2	41	39.5	35.9	33	25.1	24
30	100	96	92	57.9	55	53	48.2	44	33.5	32
37	120	115	110	69	66	64	58	53	40.8	39
45	146	140	134	84	80	77	70	64	49.1	47
55	177	169	162	102	97	93	85	78	59.6	57
75	240	230	220	139	132	127	116	106	81	77
90	291	278	266	168	160	154	140	128	97	93
110	355	340	326	205	195	188	171	156	118	113
132	418	400	383	242	230	222	202	184	140	134
160	509	487	467	295	280	270	245	224	169	162
200	637	609	584	368	350	337	307	280	212	203
250	782	748	717	453	430	414	377	344	261	250
315	983	940	901	568	540	520	473	432	327	313
355	1109	1061	1017	642	610	588	535	488	370	354
400	1255	1200	1150	726	690	665	605	552	418	400
500	1545	1478	1416	895	850	819	745	680	515	493
560	1727	1652	1583	1000	950	916	832	760	576	551
630	1928	1844	1767	1116	1060	1022	929	848	643	615
710	2164	2070	1984	1253	1190	1147	1043	952	721	690
800	2446	2340	2243	1417	1346	1297	1179	1076	815	780
900	2760	2640	2530	1598	1518	1463	1330	1214	920	880
1000	3042	2910	2789	1761	1673	1613	1466	1339	1014	970

UL/CSA Motor nominal current: single and three phase (according to UL 60947-4-1A)										
Motor power	120 V 1-ph	200 V 1-ph	200 V 3-ph	208 V 1-ph	208 V 3-ph	220-240 V 1-ph	220-240 V 3-ph	380-415 V 3-ph	440-480 V 3-ph	550-600 V 3-ph
hp	A	A	A	A	A	A	A	A	A	A
1/10	3	-	-	-	-	1.5	-	-	-	-
1/8	3.8	-	-	-	-	1.9	-	-	-	-
1/6	4.4	2.5	-	2.4	-	2.2	-	-	-	-
1/4	5.8	3.3	-	3.2	-	2.9	-	-	-	-
1/3	7.2	4.1	-	4	-	3.6	-	-	-	-
1/2	9.8	5.6	2.5	5.4	2.4	4.9	2.2	1.3	1.1	0.9
3/4	13.8	7.9	3.7	7.6	3.5	6.9	3.2	1.8	1.6	1.3
1	16	9.2	4.8	8.8	4.6	8	4.2	2.3	2.1	1.7
1-1/2	20	11.5	6.9	11	6.6	10	6	3.3	3	2.4
2	24	13.8	7.8	13.2	7.5	12	6.8	4.3	3.4	2.7
3	34	19.6	11	18.7	10.6	17	9.6	6.1	4.8	3.9
5	56	32.2	17.5	30.8	16.7	28	15.2	9.7	7.6	6.1
7-1/2	80	46	25.3	44	24.2	40	22	14	11	9
10	100	57.5	32.2	55	30.8	50	28	18	14	11
15	135	-	48.3	-	46.2	68	42	27	21	17
20	-	-	62.1	-	59.4	88	54	34	27	22
25	-	-	78.2	-	74.8	110	68	44	34	27
30	-	-	92	-	88	136	80	51	40	32
40	-	-	120	-	114	176	104	66	52	41
50	-	-	150	-	143	216	130	83	65	52
60	-	-	177	-	169	-	154	103	77	62
75	-	-	221	-	211	-	192	128	96	77
100	-	-	285	-	273	-	248	165	124	99
125	-	-	359	-	343	-	312	208	156	125
150	-	-	414	-	396	-	360	240	180	144
200	-	-	552	-	528	-	480	320	240	192
250	-	-	-	-	-	-	604	403	302	242
300	-	-	-	-	-	-	722	482	361	289
350	-	-	-	-	-	-	828	560	414	336
400	-	-	-	-	-	-	954	636	477	382
450	-	-	-	-	-	-	1030	-	515	412
500	-	-	-	-	-	-	1180	786	590	472



---

**ABB Inc. - Campus Montréal**

800, boulevard Hymus  
Saint-Laurent, QC H4S 0B5  
Phone: +1 (438) 843 6000  
Toll Free: +1 (888) 856 6266  
Customer service / Technical Support:  
ep.support@ca.abb.com

**You can find the address of your local sales organization**



<http://new.abb.com/low-voltage/products/motor-protection>



<http://www.abb.com/lowvoltage>

We reserve the right to make technical changes or modify the contents of this document without prior notice. ABB does not accept any responsibility whatsoever for potential errors or possible lack of information in this document.

We reserve all rights in this document and in the subject matter and illustrations contained therein. Any reproduction, disclosure to third parties or utilization of its contents – in whole or in parts – is forbidden without prior written consent of ABB.