

Operating instructions  
 Betriebsanleitung  
 Notice d'instructions  
 Instruktion  
 Istruzioni tecniche  
 Instrucciones de empleo

**3-pole terminal block**  
**3-polige Anschlussklemme**  
**connecteur tripolaire**  
**3-poligt uttagsdon**  
**3-polo connessione**  
**Terminal 3-polar**

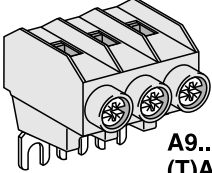





FPTC 407772 P0001-12/04 p.1



**LD16**

**A9...16**  
**(T)AE9...16**  
**(T)AL9...16**

E2768D

					
M 4	Ø5,5	pozidriv N°2	mm <sup>2</sup> 1 x 1,5...16, 2 x 1,5...6	mm <sup>2</sup> 1 x 1,5...16, 2 x 1,5...4	6 x 6 mm
1,7 N.m			1 x 16 + 1 x 1,5	1 x 10 + 1 x 1,5	E2767D

**A9...(U)A16 + 2 x LD16**  
**(T)AE9...16 + 2 x LD16**

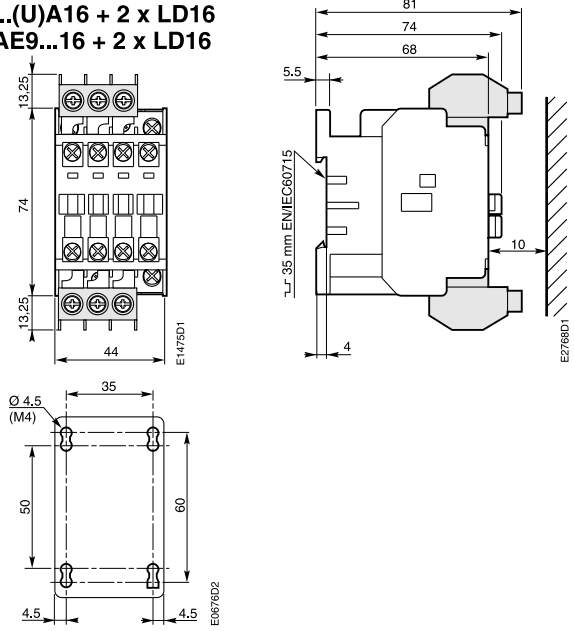

E1478D1  
E2768D  
E2768D2

**(T)AL9...16 + 2 x LD16**

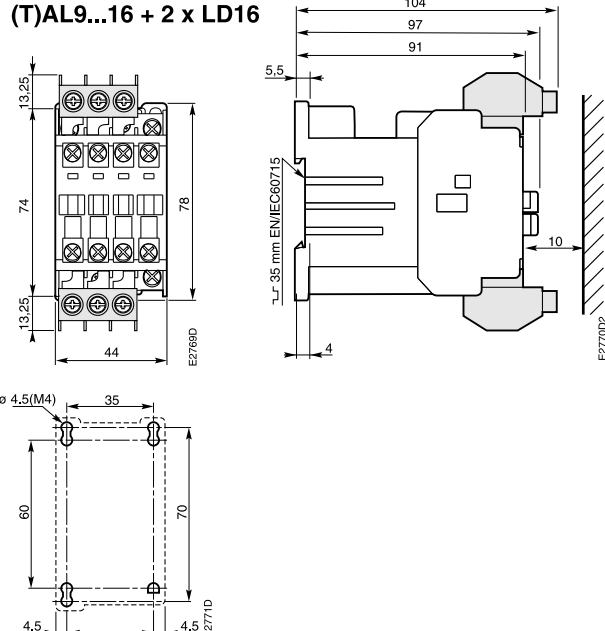

E2768D  
E2771D

**Assembly**  
**Anbau**  
**Montage**  
**Montering**  
**Montaggio**  
**Montaje**

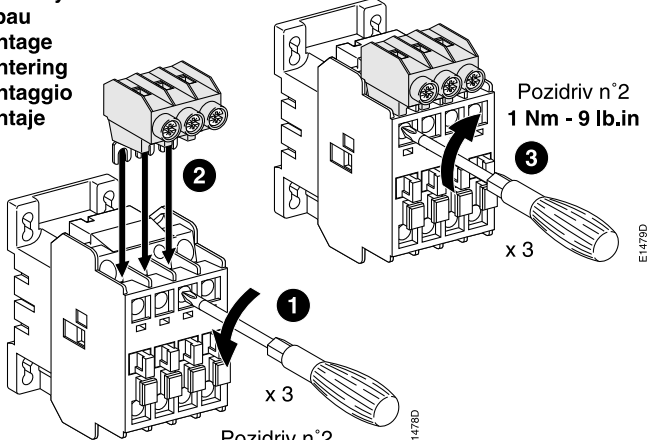

Pozidriv n°2  
1 Nm - 9 lb.in

x 3

Pozidriv n°2

E1478D

**Disassembly**  
**Abbau**  
**Démontage**  
**Demontering**  
**Smontaggio**  
**Desmontaje**

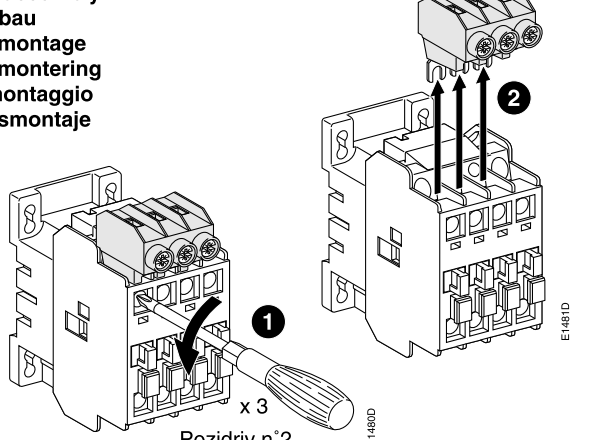

Pozidriv n°2

E1480D

**Warning !** The operation, installation and servicing of this appliance must be carried out by a qualified electrician applying the relevant rules of the art, installation standards and safety regulations. Do not touch live parts. Danger !.

**Warnung !** Die Inbetriebnahme und die Installation des vorhandenen Gerätes sowie jegliche Wartungsarbeiten müssen durch einen Fachelektriker, der die anerkannten technischen Regeln, die Montagenormen und die Sicherheitsvorschriften beachtet, durchgeführt werden. Spannung führende Teile nicht berühren. Lebensgefahr !.

**Attention !** La mise en œuvre, l'installation de cet appareil et toute intervention doivent être effectuées par un électricien professionnel appliquant les règles de l'art, les normes d'installation et les règlements de sécurité. Ne pas toucher les pièces sous tension. Danger de mort !.

**Warning !** Igångsättning och installation av apparaten samt alla ingrepp bör utföras av en kompetent elektriker enligt gällande installationsnormer och säkerhetsföreskrifter. Beröring av spänningsförande delar är förenat med livsfara.

**Attenzione !** La messa in opera, l'installazione di questo apparecchio ed ogni tipo di intervento devono essere effettuati da un elettricista professionista il quale applichi le regole del mestiere, le norme di installazione ed i regolamenti di sicurezza. Non toccare le parti attive. Pericolo di vita !



Operating instructions  
 Betriebsanleitung  
 Notice d'instructions  
 Instruktion  
 Istruzioni tecniche  
 Instrucciones de empleo





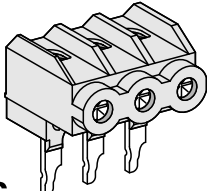

**3-pole terminal block**  
**3-polige Anschlussklemme**  
**connecteur tripolaire**  
**3-poligt uttagsdon**  
**3-polo connessione**  
**Terminal 3-polar**

FPTC 407772 P0001-12/04 p.2



**A26**  
**AE26**  
**TAE26**  
**(T)AL26**

E2772D

					
M 5 2,5 N.m	Ø5,5	pozidriv N°2	mm <sup>2</sup> 1 x 2,5...16, 1 x 16 + 1 x 4 2 x 2,5...6	mm <sup>2</sup> 1 x 2,5...16, 2 x 2,5...4 1 x 10 + 1 x 2,5	6 x 7 mm <small>E2773D</small>

**(U)A26 + 2 x LD26**  
**(T)AE26 + 2 x LD26**

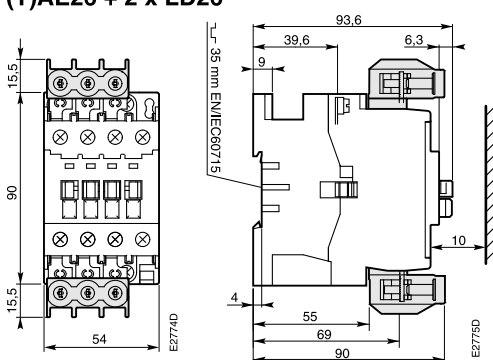

E2774D

**(T)AL26 + 2 x LD26**

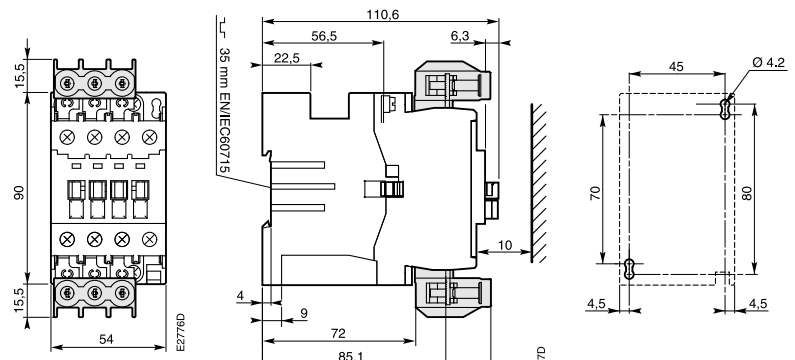

E2775D

**Assembly**  
**Anbau**  
**Montage**  
**Montering**  
**Montaggio**  
**Montaje**

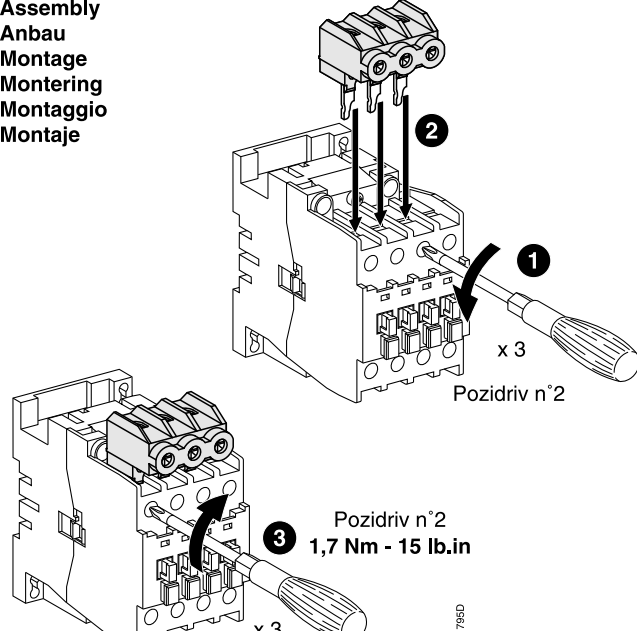

E1794D

**Disassembly**  
**Abbau**  
**Démontage**  
**Smontering**  
**Smontaggio**  
**Desmontaje**

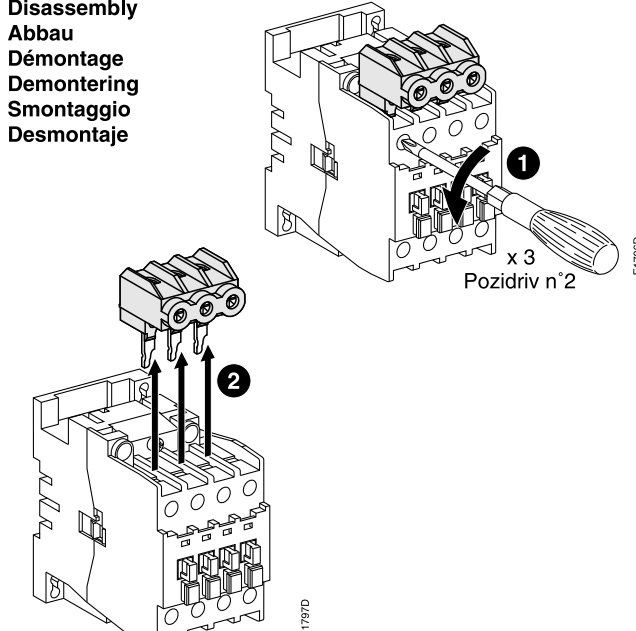

E1795D

**Warning !** The operation, installation and servicing of this appliance must be carried out by a qualified electrician applying the relevant rules of the art, installation standards and safety regulations. Do not touch live parts. Danger !

**Warnung !** Die Inbetriebnahme und die Installation des vorhandenen Gerätes sowie jegliche Wartungsarbeiten müssen durch einen Fachelektriker, der die anerkannten technischen Regeln, die Montagenormen und die Sicherheitsvorschriften beachtet, durchgeführt werden. Spannung führende Teile nicht berühren. Lebensgefahr !

**Attention !** La mise en œuvre, l'installation de cet appareil et toute intervention doivent être effectuées par un électricien professionnel appliquant les règles de l'art, les normes d'installation et les règlements de sécurité. Ne pas toucher les pièces sous tension. Danger de mort !

**Varning !** Igångsättning och installation av apparaten samt alla ingrepp bör utföras av en kompetent elektriker enligt gällande installationsnormer och säkerhetsföreskrifter. Beröring av spänningsförande delar är förenat med livsfara.

**Attenzione !** La messa in opera, l'installazione di questo apparecchio ed ogni tipo di intervento devono essere effettuati da un elettricista professionista il quale applichi le regole del mestiere, le norme di installazione ed i regolamenti di sicurezza Non toccare le parti attive. Pericolo di vita !

