

INSTRUCTION MANUAL

***MAGNETIC FLOWMETERS
10DX3111 Design Levels A & G
Sizes 14 through 24 Inches***



***MAG-X
SERIES 3000 MAGNETIC FLOWMETER***



PN24989

The following are trademarks of ABB Automation:

COPA-XM™
MAG-X®

The following is a registered trademark of E. I. du Pont de Nemours and Company:
TEFLON®

The following is a trademark of Haynes International Incorporated:

HASTELLOY™

The following is a trademark of International Nickel Company, Incorporated:

MONEL

WARNING notices as used in this manual apply to hazards or unsafe practices which could result in personal injury or death.

CAUTION notices apply to hazards or unsafe practices which could result in property damage.

NOTES highlight procedures and contain information which assist the operator in understanding the information contained in this manual.

All software, including design, appearance, algorithms and source codes, is owned and copyrighted by ABB Automation and is owned and copyrighted by ABB Automation or its suppliers.

WARNING

POSSIBLE PROCESS UPSETS

Maintenance must be performed only by qualified personnel and only after securing equipment controlled by this product. Adjusting or removing this product while it is in the system may upset the process being controlled. Some process upsets may cause injury or damage.

NOTICE

The information contained in this document is subject to change without notice.

ABB Automation, its affiliates, employees, and agents, and the authors of and contributors to this publication specifically disclaim all liabilities and warranties, express and implied (including warranties of merchantability and fitness for a particular purpose), for the accuracy, currency, completeness, and/or reliability of the information contained herein and/or for the fitness for any particular use and/or for the performance of any material and/or equipment selected in whole or part with the user of/or in reliance upon information contained herein. Selection of materials and/or equipment is at the sole risk of the user of this publication.

This document contains proprietary information of ABB Automation, and is issued in strict confidence. Its use, or reproduction for use, for the reverse engineering, development or manufacture of hardware or software described herein is prohibited. No part of this document may be photocopied or reproduced without the prior written consent of ABB Automation.

Table of Contents

SAFETY SUMMARY	I
READ FIRST	III
1.0 INTRODUCTION	1-1
1.1 General	1-1
1.1.1 Description	1-1
1.1.2 Construction	1-2
1.2 Model Number Breakdown	1-3
1.2.1 Model 10DX3111A/G	1-4
1.3 Specifications	1-6
2.0 INSTALLATION	2-1
2.1 Inspection	2-1
2.2 Meter Handling	2-2
2.3 Location	2-3
2.3.1 Standard and Accidental Submergence	2-3
2.3.2 Continuous Submergence	2-3
2.4 Mounting	2-5
2.4.1 Orientation	2-5
2.4.2 Pipe Connections	2-5
2.5 Grounding Procedure	2-8
2.5.1 General	2-8
2.5.2 Conductive Pipeline	2-8
2.5.3 Non-Conductive or Electrically Insulated Pipeline	2-11
2.5.4 Grounding Probes	2-12
2.6 Electrical Interconnection	2-13
2.6.1 General	2-13
3.0 OPERATION and START-UP	3-1
4.0 FUNCTIONAL DESCRIPTION	4-1
4.1 Basic Operating Principle	4-1
4.1.1 Signal Voltage Generation	4-1
4.1.2 Magnet Coil Drive Circuits	4-2
4.1.3 Volumetric Flow Rate Measurement	4-2
4.2 Operating Characteristics	4-3
4.2.1 Liquid Variables	4-3
4.2.1.1 Liquid Conductivity	4-3
4.2.1.2 Liquid Temperature	4-4
4.2.1.3 Other Liquid Variables	4-5
4.2.2 Metering Characteristics	4-5

5.0 CIRCUIT DESCRIPTION 5-1

5.1 Wiring Diagrams 5-2

6.0 MAINTENANCE 6-1

6.1 General 6-1

6.2 System Troubleshooting 6-2

6.3 Static Test 6-3

6.3.1 Magnet Coil Check 6-3

6.3.2 Electrode Check 6-4

7.0 PARTS LIST 7-1

7.1 Basic Meter Parts 7-1

7.2 Electronics Housing Parts 7-2

7.3 Electrode Assemblies 7-4

Figure List

FIGURE 1-1. CUTAWAY VIEW OF TYPICAL FLOWMETER	1-1
FIGURE 2-1. PROPER HOISTING TECHNIQUE	2-1
FIGURE 2-2. OUTLINE DIMENSIONS, 14" to 24" METER SIZE	2-4
FIGURE 2-3. TYPICAL PIPING DIAGRAMS	2-6
FIGURE 2-4. BOLT TIGHTENING SEQUENCE	2-7
FIGURE 2-5. GROUNDING PROCEDURE; NON-INSULATED PIPELINE	2-9
FIGURE 2-6. GROUNDING PROCEDURE; INSULATED PIPELINE	2-10
FIGURE 2-7. GROUNDING RINGS and GASKETS	2-11
FIGURE 2-8. GROUNDING PROBE (OPTIONAL)	2-12
FIGURE 2-9. INTERCONNECTION DIAGRAM, MODEL 10DX3111A	2-14 & 2-15
FIGURE 2-10. INTERCONNECTION DIAGRAM, MODEL 10DX3111G	2-16 & 2-17
FIGURE 3-1. TYPICAL INSTRUMENT TAG	3-1
FIGURE 3-2. CONTINUOUS SUBMERGENCE PRIMARY CONNECTIONS FOR REMOTE MOUNTED SIGNAL CONVERTER	3-2
FIGURE 5-1. SIMPLIFIED MAGMETER SYSTEM BLOCK DIAGRAM	5-1
FIGURE 5-2. INTERNAL WIRING DIAGRAM, MODEL 10DX3111A	5-3
FIGURE 5-3. INTERNAL WIRING DIAGRAM, MODEL 10DX3111G	5-4
FIGURE 7-1. BASIC FLOWMETER CONSTRUCTION	7-1
FIGURE 7-2. PRIMARY ELECTRONICS HOUSING ASSEMBLY	7-2
FIGURE 7-3. EXPLODED VIEW, ELECTRODE ASSEMBLIES	7-4
FIGURE 7-4. TYPICAL CONDUIT SEAL	7-5

Table List

TABLE 1-1. PRESSURE RATING vs. TEMPERATURE	1-9
TABLE 1-2. METER CAPACITY TABLE	1-10
TABLE 2-1. RECOMMENDED MOUNTING-BOLT TORQUES	2-7
TABLE 2-2. PROTECTOR PLATE AND GROUNDING RING PART NUMBERS	2-9
TABLE 6-1. METER COIL RESISTANCE	6-3

SAFETY SUMMARY

GENERAL WARNINGS

POSSIBLE PROCESS UPSETS

Maintenance must be performed only by qualified personnel and only after securing equipment controlled by this product. Adjusting or removing this product while it is in the system may upset the process being controlled. Some process upsets may cause injury or damage.

RETURN OF EQUIPMENT

All Flowmeters and/or Signal Converters being returned to ABB Automation for repair must be free of any hazardous materials (acids, alkalis, solvents, etc.). A Material Safety Data Sheet (MSDS) for all process liquids must accompany returned equipment. Contact ABB Automation for authorization prior to returning equipment.

INSTRUCTION MANUALS

Do not install, maintain or operate this equipment without reading, understanding and following the proper ABB Automation instructions and manuals, otherwise injury or damage may result.

ELECTRICAL SHOCK HAZARD

Equipment powered by AC line voltage presents a potential electric shock hazard to the user. Make certain that the system power is disconnected from the operating branch circuit before attempting electrical interconnections or service.

SPECIFIC WARNINGS

ELECTRICAL SHOCK HAZARD. Equipment powered by an AC line voltage presents a potential electric shock hazard to the user. Make certain that the system power is disconnected from the branch circuit before attempting electrical interconnections. (pg. 2-14)

ELECTRICAL SHOCK HAZARD. Equipment powered by an ac line voltage presents a potential electric shock hazard. Servicing of the Magnetic Flowmeter or Signal Converter should only be attempted by a qualified electronics technician. (pg. 6-2)

ELECTRICAL SHOCK HAZARD. Equipment that operates from ac line voltage constitutes a potential electric shock hazard to the user. Make certain that the system power is disconnected before making the following ohmmeter checks. (pg. 6-2)

Do not attempt electrode inspection or replacement with a filled or pressurized pipeline. Personal injury may result from such practice. (pg. 6-6)

**SPECIFIC
CAUTIONS**

Never allow any support for the Magnetic Flowmeter to bear upon the inner surface of the meter pipe section, as the liner may become damaged. (pg. 2-2)

Do not use a DC ohmmeter for this measurement as polarization effects will produce completely erroneous data. (pg. 4-3)

Some of the IC devices used in the signal converter are static sensitive and may be damaged by improper handling. When adjusting or servicing the signal converter, use of a grounded wrist strap is recommended to prevent inadvertant damage to the integral solid state circuitry. (pg. 6-1)

For TEFLON-lined meters, replacement of the electrodes must not be attempted in the field. The meter must be returned to the factory for electrode replacement. (pg. 6-7)

Exercise extreme care when withdrawing the electrode from its seat so that little or no tension is exerted on the connecting electrode wire. If this wire should break within the meter pipe, the meter is not repairable. (pg. 6-7)

GÉNÉRAUX AVERTISSEMENTS

PROBLÈMES POTENTIELS. La maintenance doit être réalisée par du personnel qualifié et seulement après avoir sécurisé les équipements contrôlés par ce produit. L'ajustement ou le démontage de ce produit lorsqu'il est lié au système peut entraîner des dysfonctionnements dans le procédé qu'il contrôle. Ces dysfonctionnements peuvent entraîner des blessures ou des dommages.

RETOUR D'ÉQUIPEMENT. Tout débitmètre et(ou) convertisseur retourné à ABB Automation pour réparation doit être exempt de toute trace de produit dangereux (acide, base, solvant, ...). Un certificat de sécurité matériel doit être joint pour tous les liquides utilisés dans le procédé. Contacter ABB Automation pour autorisation avant renvoi du matériel.

MANUEL DE MISE EN ROUTE. Ne pas installer, maintenir ou utiliser cet équipement sans avoir lu, compris et suivi les instructions et manuels de ABB Automation, dans le cas contraire il y a risque d'entraîner blessures ou dommages.

RISQUE DE CHOC ÉLECTRIQUE

Les équipements alimentés en courant alternatif constituent un risque de choc électrique potentiel pour l'utilisateur. Assurez-vous que les câbles d'alimentation amont sont déconnectés avant de procéder à des branchements, des essais ou tests.

SPÉCIFIQUES AVERTISSEMENTS

Les équipements alimentés en courant alternatif constituent un risque de choc électrique potentiel pour l'utilisateur. Assurez-vous que les câbles d'alimentation amont sont déconnectés avant de procéder à des branchements, des essais ou tests. (pg. 2-14)

Les équipements alimentés en courant alternatif constituent un risque de choc électrique potentiel. La maintenance sur des équipements électromagnétiques ou des convertisseurs doit être effectuée par des techniciens qualifiés. (pg. 6-2)

RISQUE DE CHOC ÉLECTRIQUE

Les équipements alimentés en courant alternatif constituent un risque de choc électrique potentiel. Assurez-vous que la puissance est déconnectée avant de procéder aux mesures de résistance suivantes. (pg 6-2)

Ne pas effectuer d'inspection ou de remplacement d'électrode lorsque la tuyauterie est pleine ou sous pression. Des blessures de personne peuvent résulter d'une telle pratique. (pg 6-6)

**SPÉCIFIQUES
ATTENTIONS**

Ne pas laisser un support de débitmètre forcer sur la surface interne de celui-ci, il pourrait en résulter un dommage sur le revêtement interne. Ne jamais soulever le débitmètre par les bossages de protection des électrodes. (pg. 2-2)

Ne pas utiliser un ohmmètre à courant continu pour cette mesure car les effets de polarisation conduiront à des mesures erronées. (pg. 4-3)

Certains Circuits Intégrés utilisés dans le convertisseur sont sensibles à l'électricité statique et peuvent être endommagés par une mauvaise manipulation. Pendant l'ajustement ou la maintenance d'un convertisseur, l'utilisation d'un bracelet antistatique est recommandé pour éviter la destruction par inadvertance d'un circuit intégré. (pg. 6-1)

Pour le revêtement TEFLON, le remplacement des électrodes ne doit pas être effectué sur le terrain. Le débitmètre doit être retourné à l'usine pour le changement d'électrode.

Faire très attention en enlevant l'électrode de son emplacement de manière à n'exercer aucune tension mécanique trop forte afin de ne pas casser le fil de raccordement de l'électrode. Si ce fil est cassé le débitmètre est irréparable.

READ FIRST

WARNING

INSTRUCTION MANUALS

Do not install, maintain, or operate this equipment without reading, understanding and following the proper ABB Automation instructions and manuals, otherwise injury or damage may result.

RETURN OF EQUIPMENT

All Flowmeters and/or Signal Converters being returned to ABB Automation for repair must be free of any hazardous materials (acids, alkalis, solvents, etc). A Material Safety Data Sheet (MSDS) for all process liquids must accompany returned equipment. Contact ABB Automation for authorization prior to returning equipment.

Read these instructions before starting installation;
save these instructions for future reference.

Contacting ABB Automation Inc.

Should assistance be required with any ABB Instrumentation product, contact the following:

Telephone:

**ABB Instrumentation Technical Support Center
1 (800) 697-9619**

E-Mail:

ins.techsupport@us.abb.com

The NEMA 4X rating applies to the meter body and electronics enclosure only. The following accessories (if supplied) may not meet NEMA 4X unless specifically ordered as NEMA 4X:

- meter flanges
- meter installation hardware: studs, nuts, bolts
- enclosure mounting hardware for pipe or wall mounting
- conduit hardware

This product is painted with a high performance epoxy paint. The corrosion protection provided by this finish is only effective if the finish is unbroken. It is the users' responsibility to "touch-up" any damage that has occurred to the finish during shipping or installation of the product. Special attention must be given to: meter flange bolting, pipe mounting of electronics, conduit entries and covers that are removed to facilitate installation or repair. For continued corrosion protection throughout the product life, it is the users' responsibility to maintain the product finish. Incidental scratches and other finish damage must be repaired and promptly re-painted with approved touch-up paint. Provide the model number and size of your product to the nearest ABB Automation representative to obtain the correct touch-up paint.

1.0 INTRODUCTION

1.1 General

1.1.1 Description

The ABB Automation Series 3000 MAG-X[®] Magnetic Flowmeters is a volumetric liquid flow rate detector. As the process transducing method, they use the characteristic of a conductive liquid generating an induced voltage when flowing through a magnetic field. The amplitude of the voltage produced is directly proportional to the flow rate of the metered fluid.

Being a completely obstructionless metering instrument, the ABB Automation Series 3000 Magnetic Flowmeter can be used to meter liquids without regard to heterogeneous consistency and will resist plugging or fouling as much as the pipeline it is mounted in. An inherent advantage of obstructionless construction is that pressure losses are reduced to levels occurring in equivalent lengths of equal diameter pipeline. This reduces or conserves pressure source requirements in new or existing hydraulic lines as compared to other metering methods. The compact size of the meter results in a light-weight unit which requires no additional support other than that used normally on pipe runs. Short laying lengths minimize the need for altering existing pipe runs to accommodate metering. A basic construction of corrosive resistant wetted parts and a variety of meter lining materials permit metering of most corrosive and reactant liquids.

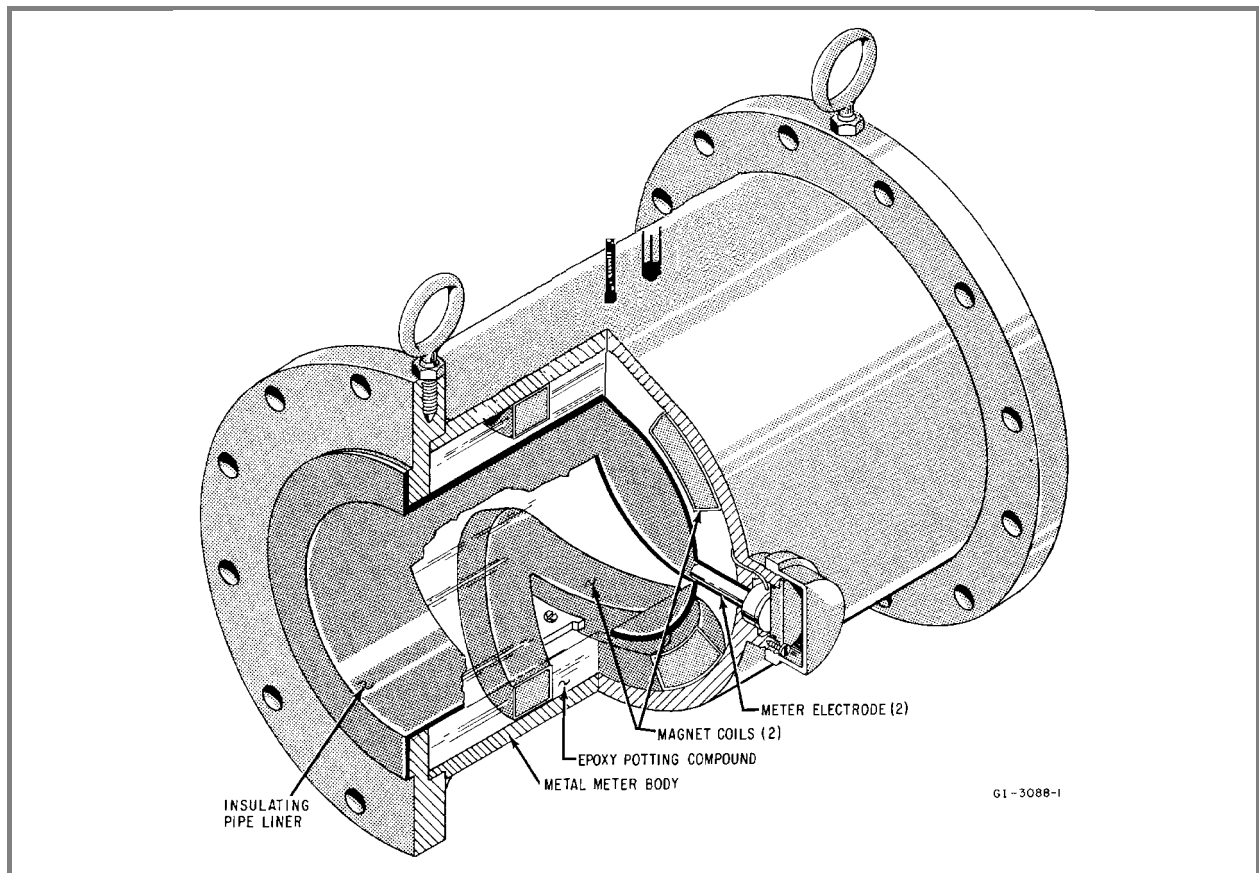

FIGURE 1-1. CUTAWAY VIEW OF TYPICAL FLOWMETER

Factors such as liquid viscosity and density require no compensation and have no effect on the measurement accuracy of the Magnetic Flowmeter. Metering limitations are confined to a minimum threshold of electrical conductivity inherent to the liquid being metered. The degree of liquid conductivity has no effect upon metering accuracy as long as it is greater than this minimum level. Liquid temperature is limited only to the extent that it may affect liquid conductivity and, like liquid pressure, to the extent that it can not exceed the meter material specification limits.

The associated electronics package is called the Signal Converter and is remotely mounted. Models 50XM1000 and M2 microprocessor-based Signal Converters are available for use with models 10DX3111A and 10DX3111G Magnetic Flowmeters respectively. The Signal Converter contains a magnet driver unit that is used to power the meter's magnet coils. The steady bipolar state magnetic field principle, referred to as the MAG-X[®] design concept, provides optimum zero point stability at an optimized drive frequency.

For information concerning the Signal Converter, refer to the Signal Converter Instruction Bulletin.

1.1.2 Construction

The ABB Automation Series 3000 Magnetic Flowmeter consists of a flanged, carbon steel pipe spool which serves as a meter body. A pair of arched, oval shaped magnet coils fit on opposite sides of the meter body inner surface as shown in Figure 1-1. The meter body provides a flow return path for the magnetic field generated by the coils. These latter components are potted inside the pipe spool to form an encapsulated assembly. Unless otherwise specified, the meter flanges are carbon steel and mate with ANSI Class 150 pipe flanges.

An insulating interior liner of either TEFLON[®] (PTFE), neoprene or polyurethane is inserted into the spool and turned-out against the flange faces. Two cylindrical electrodes are mounted diametrically opposed within the central portion of the meter body and are completely insulated from the metal pipe. The end surfaces of the standard electrodes are virtually flush with the inner surface of the insulating liner and come into contact with the liquid to be metered. Bullet nosed electrodes are mounted in a similar way; however, these electrodes protrude slightly beyond the inner surface of the liner. Standard or bullet nosed electrodes are available.

Electrode and magnet coil wiring is brought out through two access holes in the top of the meter body. Typically, electrical interconnections enter the electronic housing through a watertight cable seal fitting (see Figure 1-1). The use of metal electrical conduit is recommended for both physical protection of signal wiring and for reduction of spurious electrical signals and interference.

The primary housing sealed with a round screw-on access cover. The interior of this housing is filled with a gelatin-like silicone rubber compound which helps give the meter its waterproof rating. The internal construction of this meter is shown in Figure 3-2.

1.2 Model Number Breakdown

Refer to the ABB Automation data sheet or data tag on the equipment for the model number of the instrument furnished. The details of a specific number are shown on the following pages.

1.2.1 Model Numbers 10DX3111A&G

	10DX3111	-	E	-	-	P	1	A	-	-	-	-	-	-	2	-
Engineering Reference Obstructionless Magnetic Flowmeter																
Design Level used w/ 50XM1000 Converter used w/ M2 Converter		A G														
Meter Lay Length Replacement for 10D1435 & 10D1465		E														
Liner Material Hard Rubber Polyurethane PTFE TEFLON® Neoprene		A D E L														
Size mm (inches)																
350 (14)		21														
400 (16)		22														
450 (18)		35														
500 (20)		23														
600 (24)		24														
Flange Standard / Pressure Rating Mates with ANSI Class 150		P														
Flange Material Carbon Steel		1														
Protector Plate (TEFLON Liner only) None Required		A														
Electrode Type Flush Bullet Nose Slurry Service		2 3 7														
Electrode Material 316 Stn. Steel Hastalloy "B" Hastalloy "C" Titanium Tantalum "K" Monel Nickel Alloy 20 Zirconium		B C D E F G P Q L														

1.2.1 Model Numbers 10DX3111A & G (continued)

10DX3111 - E - P 1 A - - - -	-	-	-	-	2	-
Certification						
Standard (None)					A	
FM Approved-Nonincendive for CL I, Div 2, Gp A,B,C & D: Electrodes Intrinsically Safe for CL I, Div 1, Gp A,B,C & D: Outdoor Hazardous Locations, NEMA 4X. Dust-Ignitionproof CL II, Div 1, Gp E,F & G: Suitable for CL III, Div 1; Accidental Submergence, 33ft H ₂ O/48 h (10 m H ₂ O/48 h) [Pending]					K	
					N	
CSA Approved - CL I, Div 2 Gp A, B, C & D: CL II Div 2 Gp E,F & G: CL III Div 2; Type 4 [Pending]						
Enclosure Classification						
IEC 529 IP 65, NEMA 4X					1	
Accidental Submergence, IEC 529 IP 67, NEMA 4X, 33ft H ₂ O/48h (10m H ₂ O/48h)					2	
Continuous Submergence, IEC 529 IP 68, NEMA 4X, 33ft H ₂ O (10m H ₂ O), Continuous Duty, Signal Cable permanently installed					5	
Accidental Submergence, IEC 529 IP 67, NEMA 4X, 33ft H ₂ O/48h (10m H ₂ O/48h), Tropical-Improved moisture protection, Signal Cable permanently installed					9	
Liquid Temperature Range						
Teflon, < 266° F (130° C)					1	
Hard Rubber, < 176° F (80° C)					3	
Neoprene / Polyurethane < 190° F (88° C)					4	
Teflon, < 302° F (150° C)					5	
Line Excitation Frequency						
50 Hz / 6-1/4 Hz					1	
50 Hz / 12-1/2 Hz					2	
60 Hz / 7-1/2 Hz					3	
60 Hz / 15 Hz					4	
Customer Information Language						
English						2
Converter Type						
50XM1000 [Design Level A only] / M2 [Design Level G only]						1
None						X

1.3 Specifications

Power Requirements See 1.2 Model Number Breakdown

Power Consumption 23VA typical
Refer to Converter Instruction Bulletin, as specified, to supplement this data.

Flowmeter Characteristics:

Meter Size/Flow Capacity See TABLE 1-2.

Span Factory set at specified range between extremes listed in TABLE 1-2; can be field adjusted.

Rangeability 100:1

Minimum Fluid Conductivity 5 μ S/cm

System Accuracy:

	Flowrate	Accuracy
Frequency Output	<2% of meter capacity	$\pm 0.01\%$ of meter capacity
	>2% of meter capacity	$\pm 0.5\%$ of rate
4-20 mA Output		add $\pm 0.1\%$ of span to above numbers

Meter Capacity specified on primary data tag (equal to max flow capacity in engineering units). This factor is equivalent to a flow velocity of 10 m/s in the metering tube.

Environmental Limits:

Enclosure Classification (Standard Meter) IEC 529 IP65; NEMA 4X, indoor or outdoor installation

Accidental Submergence Option IEC 529 IP67; NEMA 4X, 33 ft. H₂O/48h (10m H₂O/48 h)

Continuous Submergence Option IEC 529 IP68; NEMA 4X, 33 ft. H₂O depth (10m H₂O depth)

Relative Humidity 10% to 90% (non-condensing)

Ambient Temperature Limits at primary **Max:** 140°F(60°C) for Process Temperatures up to 266°F (130°C). Max. temperature is reduced by 1° for each degree increase in process temperature above 266°F (130°C)

Min: -13°F (-25°C)

Process Limits:

Liner Temperature

TEFLON®	302°F (150°C)
Polyurethane/Neoprene	190°F (88°C)
Hard Rubber	176°F (80°C)

Pressure Limits at 38°C (100°F) and Carbon Steel Flanges (ANSI Class 150) Pressure Rating (Max.): MPa (psig) [Refer to Table 1-1]

TABLE 1-1. PRESSURE RATING vs. TEMPERATURE - MPa (psi)

METER SIZE		ANSI CLASS	FLANGE MATERIAL	NEOPRENE/POLYURETHANE		TEFLON	
mm	(INCHES)			38°C(100°F)	88°C(190°F)	38°C(100°F)	150°C(302°F)
350	(14)	150	Carbon St.	1.90 (275)	1.65 (240)	1.72 (250)	1.45 (210)
400	(16)	150	Carbon St.	1.90 (275)	1.65 (240)	1.55 (225)	1.45 (210)
450	(18)	150	Carbon St.	1.41 (205)	1.34 (195)	1.14 (165)	1.03 (150)
500	(20)	150	Carbon St.	1.55 (225)	1.45 (210)	1.28 (185)	1.17 (170)
600	(24)	150	Carbon St.	1.52 (220)	1.41 (205)	1.34 (195)	1.24 (180)

Physical Characteristics:

Outline Dimensions

Standard & Accidental Submergence See Figure 2-2

Continuous Submergence Option See Figure 2-3

Vibration Limit 1.5g for 10-150 Hz.

Signal Cable Length for meters with permanently installed cable (supplied by ABB Automation, when applicable)

Standard Length 50 ft (15 m)

Optional Length Up to 200 ft (60 m) available

Materials of Construction:

Meter Liner	TEFLON [®] , Hard Rubber, Polyurethane or Neoprene, as specified.
Electrode Assembly	see Section 1.2, Model Number Breakdown
Meter Body	304 Stainless Steel
Flanges	carbon steel
Meter Housing	cast aluminum
Customer Connection Box	die cast aluminum
Conduit Connections	1/2" NPT conduit seal connections
Safety Certification	refer to Section 1.2, Model Number Breakdown

Accessories

Grounding Rings	304 Stainless Steel
-----------------	---------------------

TABLE 1-2. METER CAPACITY TABLE

METER SIZE mm (INCHES)	METER CAPACITY*		FLOW RANGES, 0 TO TABULATED VALUE				CUSTOMER RANGE (IF UNSPECIFIED)	
			MINIMUM		MAXIMUM			
	GPM (US)	m ³ /h	GPM (US)	m ³ /h	GPM (US)	m ³ /h	GPM (US)	m ³ /h
350 (14)	14,530	3,300	291	66	14531	3,300	4500	1000
400 (16)	19,815	4,500	396	90	19815	4,500	6000	1400
450 (18)	26,420	6,000	528	120	26420	6,000	8000	1800
500 (20)	29,062	6,600	581	132	29062	6,600	9000	2000
600 (24)	42,272	9,600	845	192	42272	9,600	13000	3000

* Flow Velocity (ft/s) = (Operating GPM x 32.81)/Meter Capacity

2.0 INSTALLATION

2.1 Inspection

The Series 3000 MAG-X Magnetic Flowmeter and the associated Signal Converter are normally combined for shipment. For example, the 14" size meter is shipped in a heavy-duty carton which is specially designed to protect the equipment during shipment. The 16" and larger size meters are strapped to a wooden skid that both protects the metering system and facilitates handling of this heavy equipment with a fork lift truck (typical). A table of meter weights is provided on the outline dimension drawing (see Figure 2-2). An itemized list of all items included in the shipment is attached to the package or container.

Inspect all items included in the shipment immediately for indications of damage which may have occurred during shipment. A thorough visual inspection of the shipment contents is normally all that is required to determine whether damage is evident. All claims of damage should be reported to the shipping agent involved before attempting to install or operate this equipment. If damage is such that faulty operation is likely to result, the damage should be brought to the attention of the ABB Automation Service Department.

Performing inspection at the installation site is preferred because it is easier to transport the meter and Signal Converter in the original shipping container. Should it be necessary to lift the Magnetic Flowmeter, attach the cables from a winch or block and tackle to the lifting lugs in the meter flanges as shown in Figure 2-1 (**Note that the illustration is for references purposes only and that the meter shown may not represent the actual model described in this instruction manual**). The cable used must be able to support meter weights as tabulated on the outline dimension diagram. The cable must be long enough to form an angle of 45° or more between the lifting line and the meter pipe axis. **DO NOT** try to lift the meter by attaching cables to the electrode bosses.

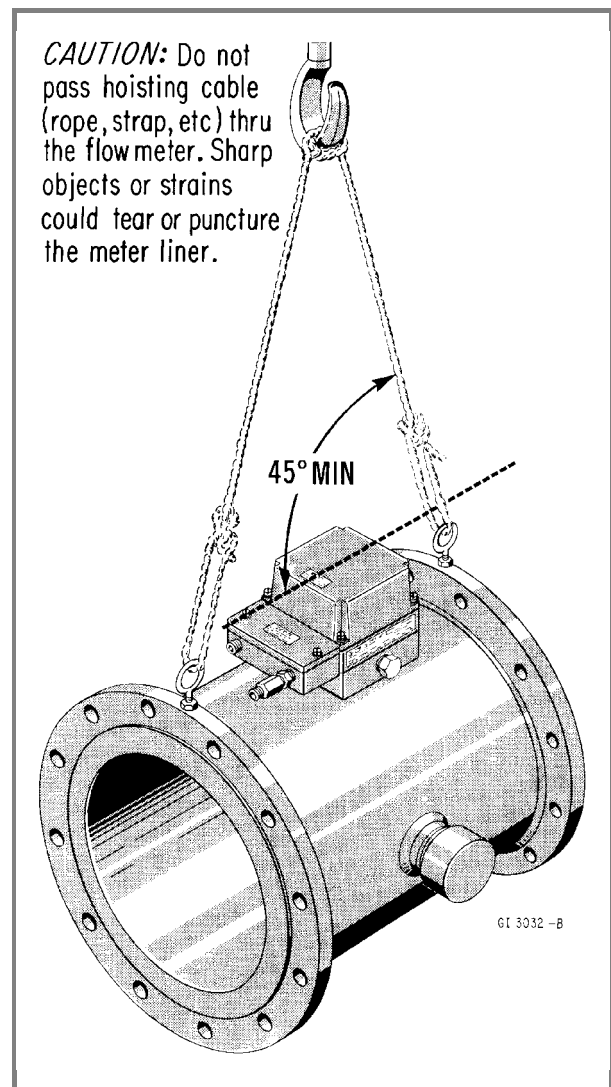

FIGURE 2-1. PROPER HOISTING TECHNIQUE

2.2 Meter Handling

The exposed liner material on the faces of both meter flanges are susceptible to damage if mishandled. Do not walk the meter on its ends. Always use the protective end covers when the meter is transported. These protective end covers can be removed for inspection and must be removed before mounting the meter in the pipeline.

CAUTION

Never allow support for the Magnetic Flowmeter to bear upon the inner surface of the meter pipe section inasmuch as the liner may become damaged. Do not lift the meter by the electrode bosses.

As shown in Figure 2-9, ABB Automation has developed a liner protector/grounding ring for the 14 inch TEFLON[®] lined meters. These protector plates are turned on both the inside and outside edges. Turning the inside edge protects the leading edge of the meter liner from process abrasion. Turning the outside edge reduces the probability that a prying tool will be jammed against the liner during removal of the meter from the line.

NOTE

When liner protector plates/grounding rings are attached to the meter flanges, do not remove them; removal will cause the TEFLON[®] liner to have a tendency to curl away from the meter flange where it can be easily damaged.

A TEFLON[®] liner of the flowmeter must be protected at all times for two reasons.

- the TEFLON[®] can be damaged by sharp objects or cut by undue pressure
- if the pressure on the flanges is relieved the TEFLON will tend to curl away from the flange

Also included in the shipping crate is an installation kit, which consists of the following items:

- a) Two gaskets
- b) Required seal fittings (depending on model).

The proper use of these items as described in the following text, and the proper employment of them during installation is necessary to maintain a valid instrument warranty. In some cases, the installation of the meter and the corresponding gaskets may be made easier by using talcum powder (or a similar dry lubricant) on the gaskets to allow the gaskets to slide more easily over the lined flange face during the installation procedure.

2.3 Location

2.3.1 Standard and Accidental Submergence

The Flowmeter is suitable for either indoor or outdoor installation. When selecting the installation site, consideration should be given to the ambient and process temperature limits, as stated in Section 1.3 Specifications. Consideration should be given to access for servicing the meter. The standard meter is rated NEMA 4X, watertight, and will thus stand rain and hose down. If flooding is a problem, the optional IEC 529 IP67 flowmeter is well suited for occasional submersion.

The Signal Converter includes RFI filters that provide excellent protection against radiated RFI/EMI. Therefore, stray electromagnetic and electrostatic fields, low power radio transmissions, etc. will have no effect upon the operating characteristics of the electronic package of the MAG-X Magnetic Flowmeter systems. It is recommended, however, that the meter not be installed within the immediate proximity of heavy induction equipment.

Provide access for wiring interconnections and occasional servicing of the meter. At least 5 inches overhead clearance is required for cover removal. Outline dimensions of the remote mounted Signal Converter are given in the Instruction Bulletin supplied with the Signal Converter.

The installation site must be provided with a convenient source of power as specified for the Signal Converter. The power line should have a disconnect switch, and a suitable fuse or circuit breaker as shown on the applicable interconnection diagram (provided in the Instruction Bulletin supplied with the Signal Converter). If the pipeline is not a good ground, a suitable earth ground must be made available in proximity to the installation site.

In-line meter maintenance is minimized as no operating adjustments are required in the Magnetic Flowmeter. Servicing accessibility is of secondary importance unless greasy sludges or liquids bearing insulating materials which tend to coat pipe walls are to be metered. However, sufficient access room should be allocated to facilitate electrical interconnection and permit field replacement of electrodes should the need arise.

Outline dimensions for the flowmeters are shown in Figure 2-2.

2.3.2 Continuous Submergence

The continuous submergence option, when specified, contains special design features that permit the meter to operate properly when submerged completely under water or buried in the ground. The Primary contains special liquid-tight fittings on top of the meter that properly seal the signal and coil excitation cable entry ports. The interconnection between primary and converter may be seen in Figure 2-10.

The 50XM or M2 converter furnished with this design has an additional circuit assembly (P/N 686B735U07) which establishes the correct coil excitation current for the primary. Take notice of the required connections to converter terminals M1 & MR for this configuration. In addition, the heavy black wire connected to terminal #3 of the primary must be connected to terminal #3 in the converter along with the .025 square post connection already present.

Once installation is complete, full flow must be established to purge all entrapped air in the pipeline. A system zero must then be performed under a full pipe, no flow condition. Refer to the instruction bulletin provided with the converter for instructions on performing this procedure.

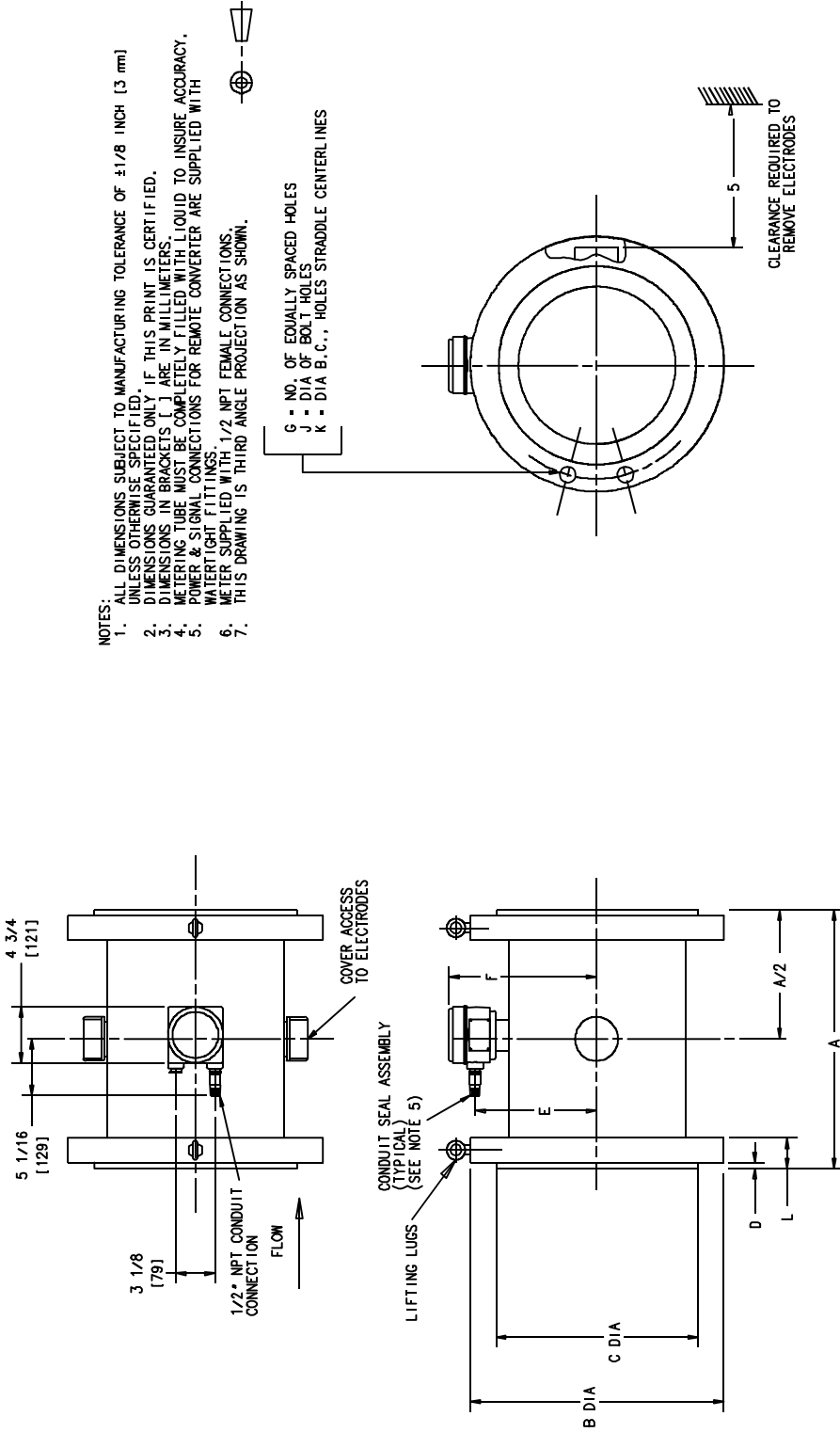

- NOTES:
1. ALL DIMENSIONS SUBJECT TO MANUFACTURING TOLERANCE OF ±1/8 INCH [3 mm] UNLESS OTHERWISE SPECIFIED.
 2. DIMENSIONS GUARANTEED ONLY IF THIS PRINT IS CERTIFIED.
 3. DIMENSIONS IN BRACKETS [] ARE IN MILLIMETERS.
 4. METERING TUBE MUST BE COMPLETELY FILLED WITH LIQUID TO INSURE ACCURACY.
 5. POWER & SIGNAL CONNECTIONS FOR REMOTE CONVERTER ARE SUPPLIED WITH WATERTIGHT FITTINGS.
 6. METER SUPPLIED WITH 1/2 NPT FEMALE CONNECTIONS.
 7. THIS DRAWING IS THIRD ANGLE PROJECTION AS SHOWN.

METER SIZE & STYLE	A		B		C		D		E		F		G		J		K		L	
	INCH	mm	INCH	mm	INCH	mm	INCH	mm	INCH	mm	INCH	mm	INCH	mm	INCH	mm	INCH	mm	INCH	mm
14IN ANSI CL. 150	21	533	21	533	16-1/4	413	5/16	8	10-13/16	275	13-1/16	332	12	12	1-1/8	29	18-3/4	476	1-5/8	41
16IN ANSI CL. 150	24	606	23-1/2	597	18-1/2	470	5/16	8	11-13/16	300	14-1/16	357	16	16	1-1/8	29	21-1/4	540	1-11/16	43
18IN ANSI CL. 150	27	686	25	635	21	533	5/16	8	12-13/16	325	15-1/16	383	16	16	1-1/4	32	22-3/4	578	1-13/16	46
20IN ANSI CL. 150	30	762	27-1/2	699	23	584	5/16	8	13-13/16	351	16-1/16	408	20	20	1-1/4	32	25	635	1-15/16	49
24IN ANSI CL. 150	36	914	29-1/2	749	27-1/4	692	5/16	8	15-13/16	402	18-1/16	459	20	20	1-3/8	35	29-1/2	749	2-1/8	54
14IN ANSI CL. 300	21	533	23	584	16-1/4	413	5/16	8	10-13/16	275	13-1/16	332	20	20	1-1/4	32	20-1/4	514	2-3/8	60
16IN ANSI CL. 300	24	606	25-1/2	648	18-1/2	470	5/16	8	11-13/16	300	14-1/16	357	20	20	1-3/8	35	22-1/2	572	2-1/2	64
18IN ANSI CL. 300	27	686	28	711	21	533	5/16	8	12-13/16	325	15-1/16	383	24	24	1-3/8	35	24-3/4	629	2-5/8	67
20IN ANSI CL. 300	30	762	30-1/2	775	23	584	5/16	8	13-13/16	351	16-1/16	408	24	24	1-3/8	35	27	666	2-3/4	70
24IN ANSI CL. 300	36	914	36	914	27-1/4	692	5/16	8	15-13/16	402	18-1/16	459	24	24	1-5/8	41	32	813	3	76

10d4397r0

FIGURE 2-2. OUTLINE DIMENSIONS, 14" to 24" METER SIZE

2.4 Mounting

2.4.1 Orientation

The ABB Automation Series 3000 Magnetic Flowmeter may be installed in horizontal, vertical or sloping pipe runs. However, precautions must be taken to assure that the metering tube is filled at all times during measurement. A vertical installation, with the pipe line carrying fluid upwards assures a filled hydraulic line under low flow rate conditions and also minimizes wear on the meter lining by abrasive grit. Horizontal installations should be made with the meter in the lower section of a pipeline to assure a filled meter condition.

For horizontal or sloping installations the meter should be placed so that the electronic housing of the meter is on top. This will align the meter electrodes in a lateral plane. Positioning the meter in this way eliminates the possibility of entrained air acting as an electrode insulator. (Electrodes must not be on "top" when the meter is horizontally mounted.)

The MAG-X Magnetic Flowmeter must be oriented in accordance with the direction of process flow, as indicated by the FLOW arrow on the meter data tag. For accurate metering, a straight pipe run equivalent to a minimum of three straight pipe diameters are required upstream of the meter, measured from the center of the meter. See Figure 2-3 for recommended piping diagrams (**Note that the illustration is for references purposes only and that the meter shown may not represent the actual model described in this instruction manual**).

If a throttling valve is required, it is strongly recommended that it be placed downstream of the meter. Upstream valves can create turbulence that result in undesirable air pockets and may affect the meter's accuracy or cause its output to be noisy. If greasy sludges or insulating materials which tend to coat pipe walls are to be metered, it is recommended that in addition to standard block valves and bypass line, a clean-out tee be installed to facilitate meter cleaning without removal or interruption of the process.

2.4.2 Pipe Connections

Standard meter piping connections are made by means of flanges that conform to ANSI standards in outside diameter and bolt circle. The bearing surfaces of the flanges are insulated with the meter pipe liner. Figure 2-2 provides outline and mounting dimensions of the standard Series 3000 large diameter Magnetic Flowmeters. Outline and mounting dimensions for the remote mounted Signal Converter are shown in the Instruction Manual supplied with the Signal Converter.

It is generally recommended that two pipe spools be installed while the flowmeter is out of the pipeline, one on each end fitting of the meter, in order to minimize the possibility of damage to the meter pipe and flange liner during mounting. Lined spool pieces and/or special length spools are available on special order. (Exception - see NOTE below. TEFLON[®] Lined Meters).

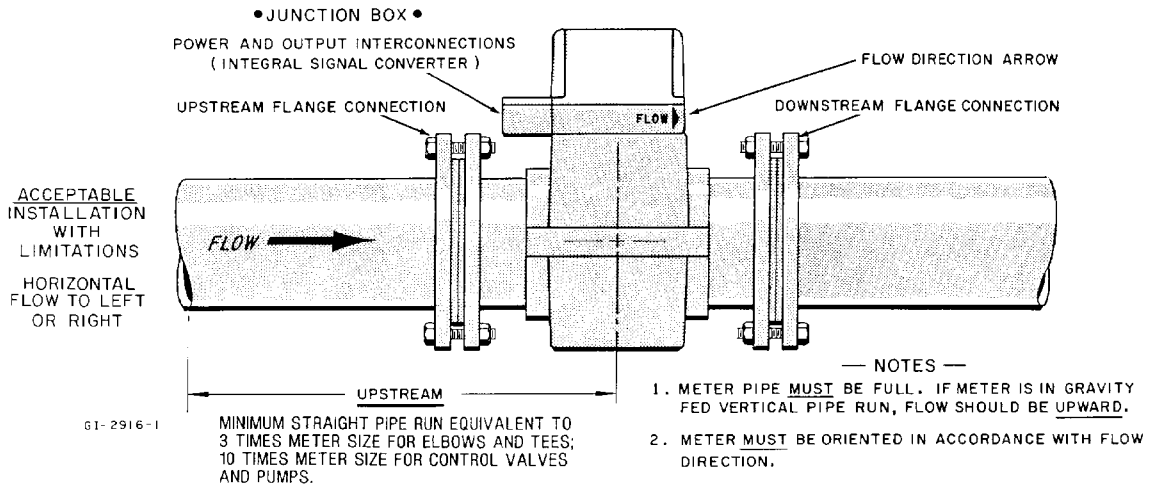
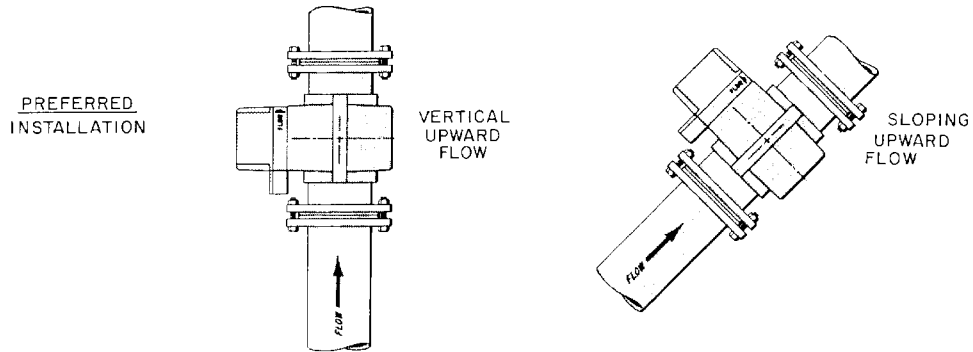
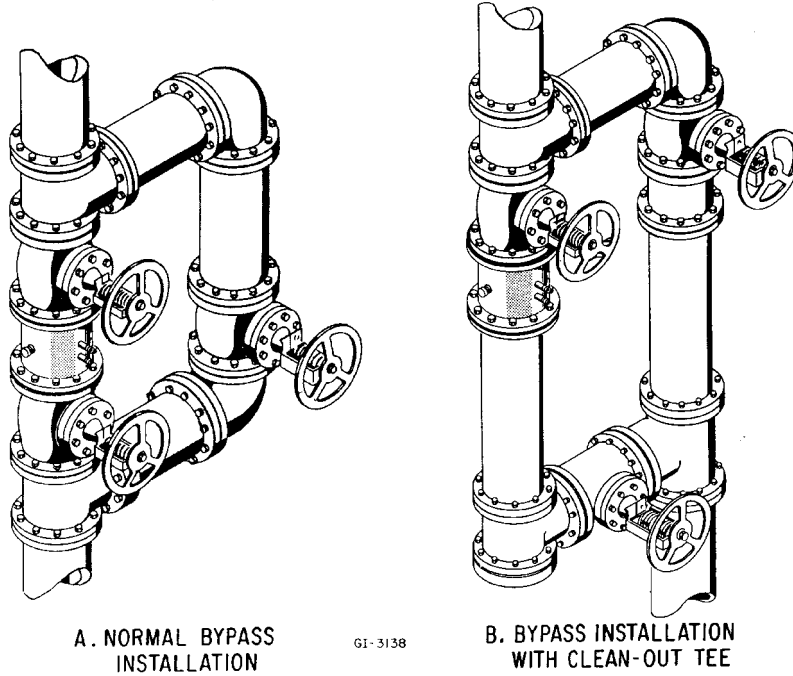

FIGURE 2-3. TYPICAL PIPING DIAGRAMS

A pair of the proper gaskets to suit the particular lining option of the meter supplied is included within the installation kit which accompanies the Magnetic Flowmeter. Before connections are made, the bearing surfaces of neoprene or polyurethane-lined meter flanges, their neoprene gaskets and adjacent pipeline flanges must be thoroughly dusted with talcum powder. This is done to prevent possible damage to the meter lining or gaskets, should the meter be removed from the line.

If the Magnetic Flowmeter is to be mounted in a non-conductive pipeline or a metal pipeline with an insulating liner, the user must provide a pair of suitable gaskets between the customer-supplied annular meter grounding rings (discussed under Section 2.5.2) and the adjacent pipeline flange surfaces.

The standard coarse thread flange bolts supplied by the user must be well lubricated and tightened in even increments around the flange surface using a "star" pattern as shown in Figure 2-4. Note that 14 through 24 inch meters will have a correspondingly larger number of bolt holes as shown in Table 2-1.

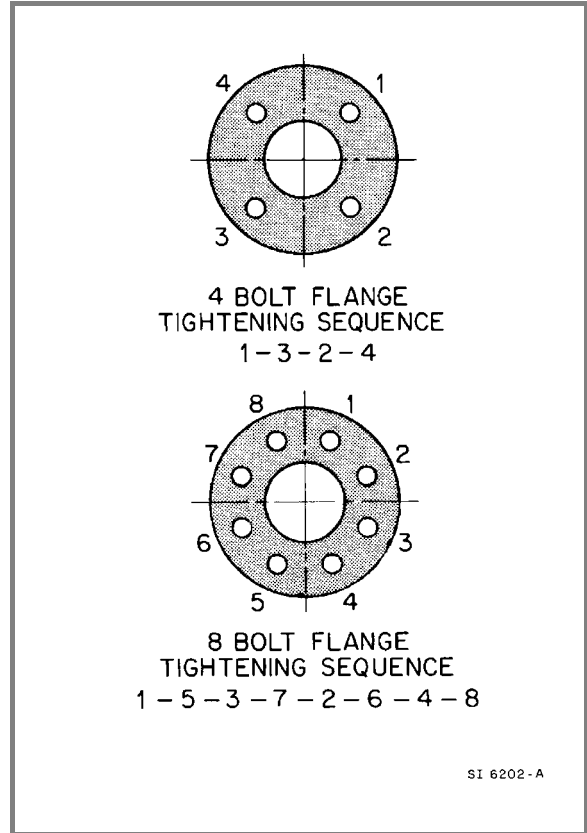

FIGURE 2-4. BOLT TIGHTENING SEQUENCE

Bolt torque should be limited to that which will produce a positive seal for the application. Recommended mounting-bolt torque values are shown in Table 2-1 below.

TABLE 2-1. RECOMMENDED MOUNTING-BOLT TORQUES

Meter Size	ANSI Class 150				ANSI Class 300			
	# of Holes	Bolt Size [Diam.] (in.)	ft. lbs.	Nm	# of Holes	Bolt Size [Diam.] (in.)	ft. lbs.	Nm
14	12	1	120	160	20	1 1/8	215	125
16	16	1	115	155	20	1 1/4	310	175
18	16	1 1/8	175	240	24	1 1/4	335	195
20	20	1 1/8	155	210	24	1 1/4	400	215
24	20	1 1/4	220	300	24	1 1/2	675	335

Notes:

1. Torques listed are for bolts with threads lubricated.
2. All meters with PTFE liners need to be re-torqued after 48 hours of operation.

2.5 Grounding Procedure

2.5.1 General

Satisfactory operation of ABB Automation Magnetic Flowmeter Systems requires that careful attention be paid to proper grounding techniques. A good ground is one that is in contact with the earth over a large conductive area. An excellent example of this is a cold water pipe which is buried in the earth and travels many miles in its distribution system. A great number of pipe branches form a large conductive area of contact which provides a low resistance connection to earth. A hot water or steam pipe must first return to a boiler before it becomes a cold water pipe, and therefore, its greater length of ungrounded path offers a less desirable ground bus. A metallic structural member of a building, such as a supporting "I"-beam, may be a good earth ground, but it is a second choice to a cold water pipe.

Meter grounding requirements are really a combination of standard grounding methods and a bonding of the meter body to the process liquid. The most important of these is the process bonding, which is nothing more than ensuring that the meter body is in contact with the process liquid at both ends of the meter body. Basically, the bonding procedure places an electrical short circuit across the meter, thereby routing any stray current around the liquid in the meter (rather than through it).

From the point of view of grounding there are two basic types of piping systems:

- electrically conductive pipeline: the process liquid comes in contact with conductive pipe. This piping requires that each meter flange be connected with a bonding wire to the adjacent pipeline flange as shown in Figure 2-5. The grounding procedure to use with conductive pipeline is described in 2.5.2.
- non-conductive or electrically insulated pipeline: the pipeline may be made of an electrically non-conductive material (plastic pipe, bituminous-coated cast iron pipe, concrete, etc.) or lined with a non-conductive material (rubber, TEFLON[®], etc). These non-conductive pipelines require the use of metal grounding rings or grounding probes (see Figures 2-6 through 2-8) to bond the process liquid to ground. The grounding procedure to use with a nonconductive pipeline is described in 2.5.3.

Proper grounding of the Magnetic Flowmeter is required for optimum system performance.

2.5.2 Conductive Pipeline

If the flowmeter is included as part of a conductive pipeline that is not electrically insulated from the liquid to be metered, the following grounding procedure should be followed. Refer to Figure 2-5 to supplement the text.

- 1) Drill and tap both pipeline flanges adjacent to the bonding connections on the flowmeter. The lugs on the bonding cables are sized for metric M6 fasteners (a 1/4" hex head bolt).
- 2) Obtain a bright metal surface around the edges of the tapped hole with a file or burnishing tool.
- 3) Attach the bonding wire and another length of ground wire to the flanges as shown. Use internal tooth lockwashers as shown in the detail. The wire to the good external ground should be #12 AWG, or heavier, copper wire.

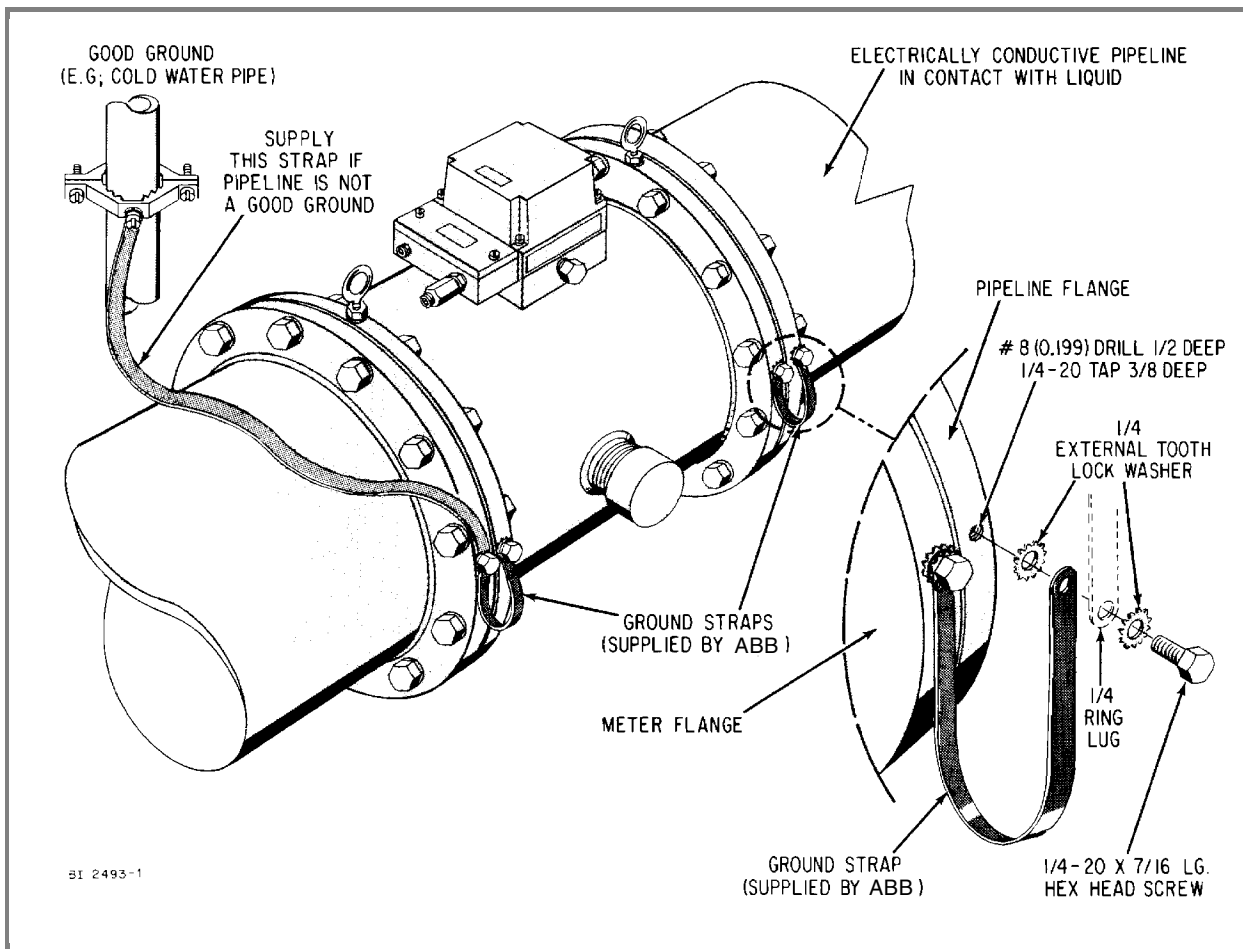

FIGURE 2-5. GROUNDING PROCEDURE; NON-INSULATED PIPELINE

(Note that the illustration is for references purposes only and that the meter shown may not represent the actual model described in this instruction manual)

TABLE 2-2. PROTECTOR PLATE AND GROUNDING RING PART NUMBERS

FLANGE RATING (ANSI)		ANSI CLASS 150	
RING MATERIAL		304 SS	
GASKET MATERIAL		NEOPRENE	TEFLON [®]
FLANGE SIZE (Inches)	BASIC PART NUMBER	PART NUMBER SUFFIX*	
GROUNDING RING			
14	644B009	U09	U10
16	644B009	U11	U12
18	644B009	U13	U14
20	644B009	U15	U16
24	644B009	U17	U18

* Add suffix to basic part number to complete the part number, e.g., 644B009U11 for a 16" 304 stainless steel grounding ring with a NEOPRENE gasket.

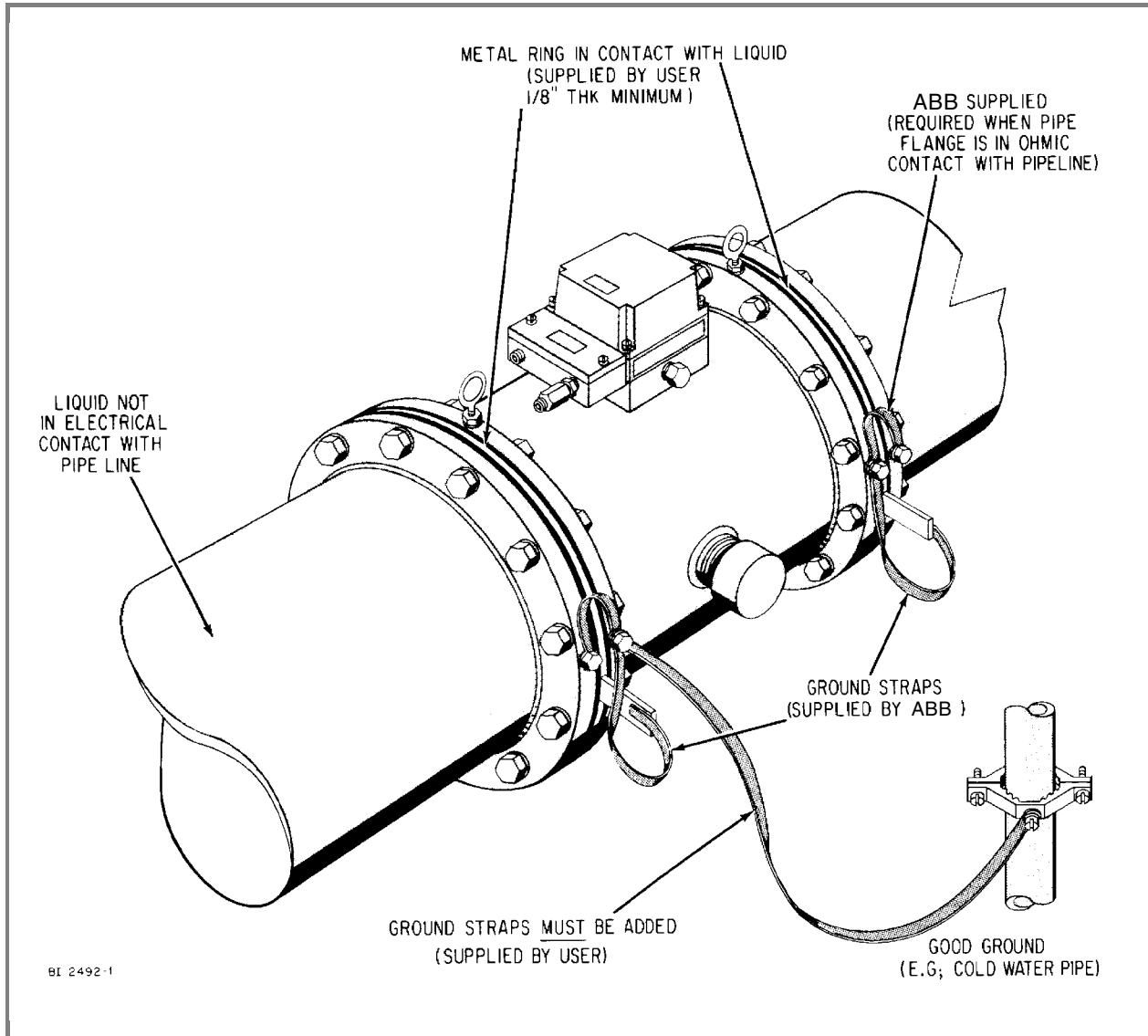

FIGURE 2-6. GROUNDING PROCEDURE; INSULATED PIPELINE

(Note that the illustration is for references purposes only and that the meter shown may not represent the actual model described in this instruction manual)

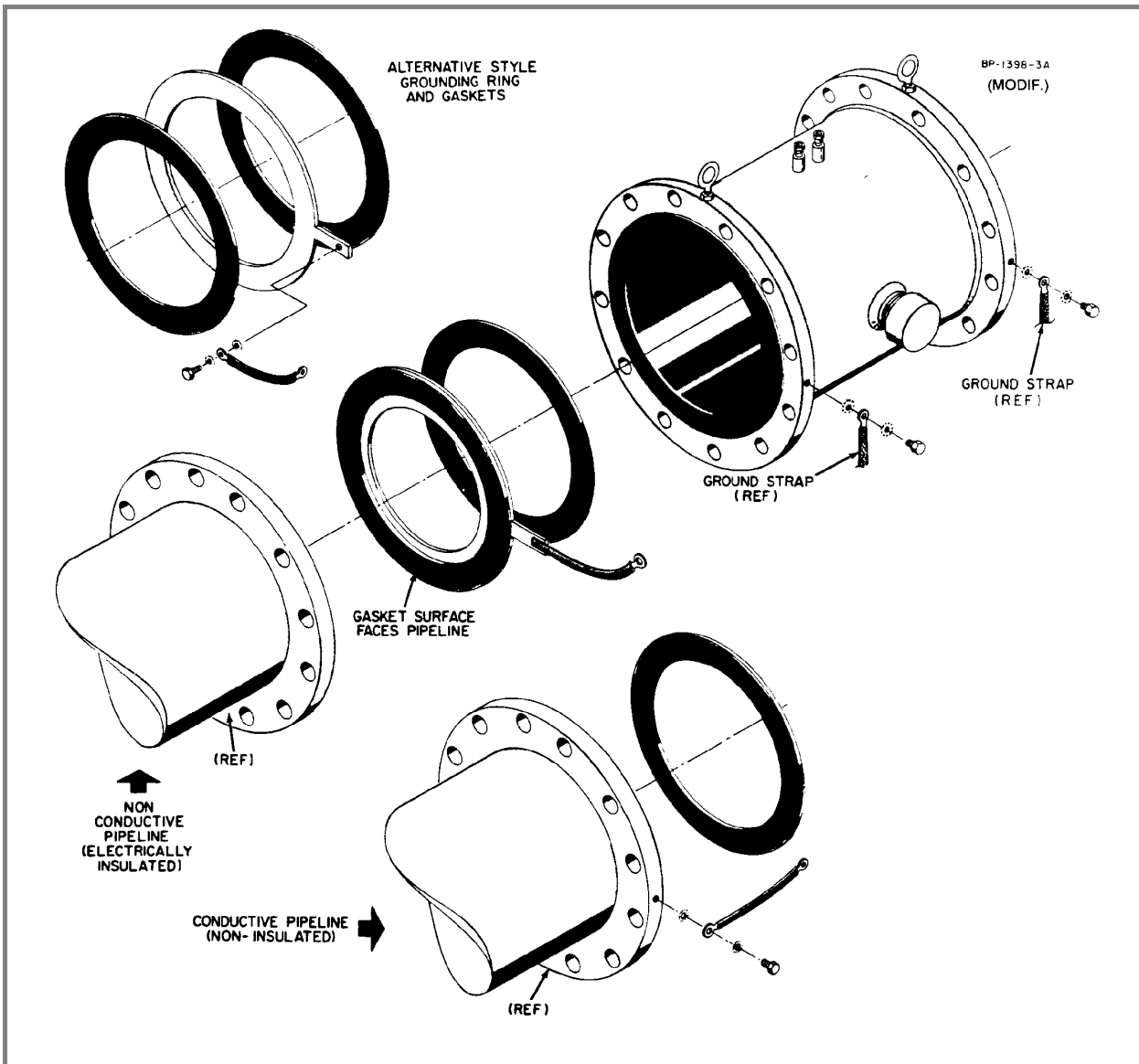

FIGURE 2-7. GROUNDING RINGS and GASKETS

2.5.3 Non-Conductive or Electrically Insulated Pipeline

If the flowmeter is included as part of a non-conductive or liquid insulated pipeline (such as totally plastic pipe, ceramic lined iron pipe, or cast pipe with internal bitumastic coating), the following grounding procedures apply. Refer to Figure 2-6 to supplement the following text.

- 1) Usually, for this service, the meter has been specified to have liner protector/grounding rings. If not, obtain a pair of grounding rings and attach them to the meter as shown in Figure 2-6. No gasket is required between the grounding ring and the meter since it mates with the liner. However, a gasket is required between the grounding ring and the process flange of the pipeline.
- 2) Attach the bonding wire and another length of ground wire to the tab of the grounding ring. Use internal tooth lockwashers and hex head nut and bolts for attachment as shown in the detail on Figure 2-6. The wire to the good ground should be #12 AWG, or heavier, copper wire.

2.5.4 Grounding Probes (2 required)

The grounding probe shown in Figure 2-8 can be substituted for grounding rings in many applications when non-conductive or electrically insulated pipe is used. The pipeline must be drilled and tapped as shown in Figure 2-8, with the grounding probes installed adjacent to each of the pipeline mounting flanges. Connect a grounding strap or wire from each probe to the meter flanges.

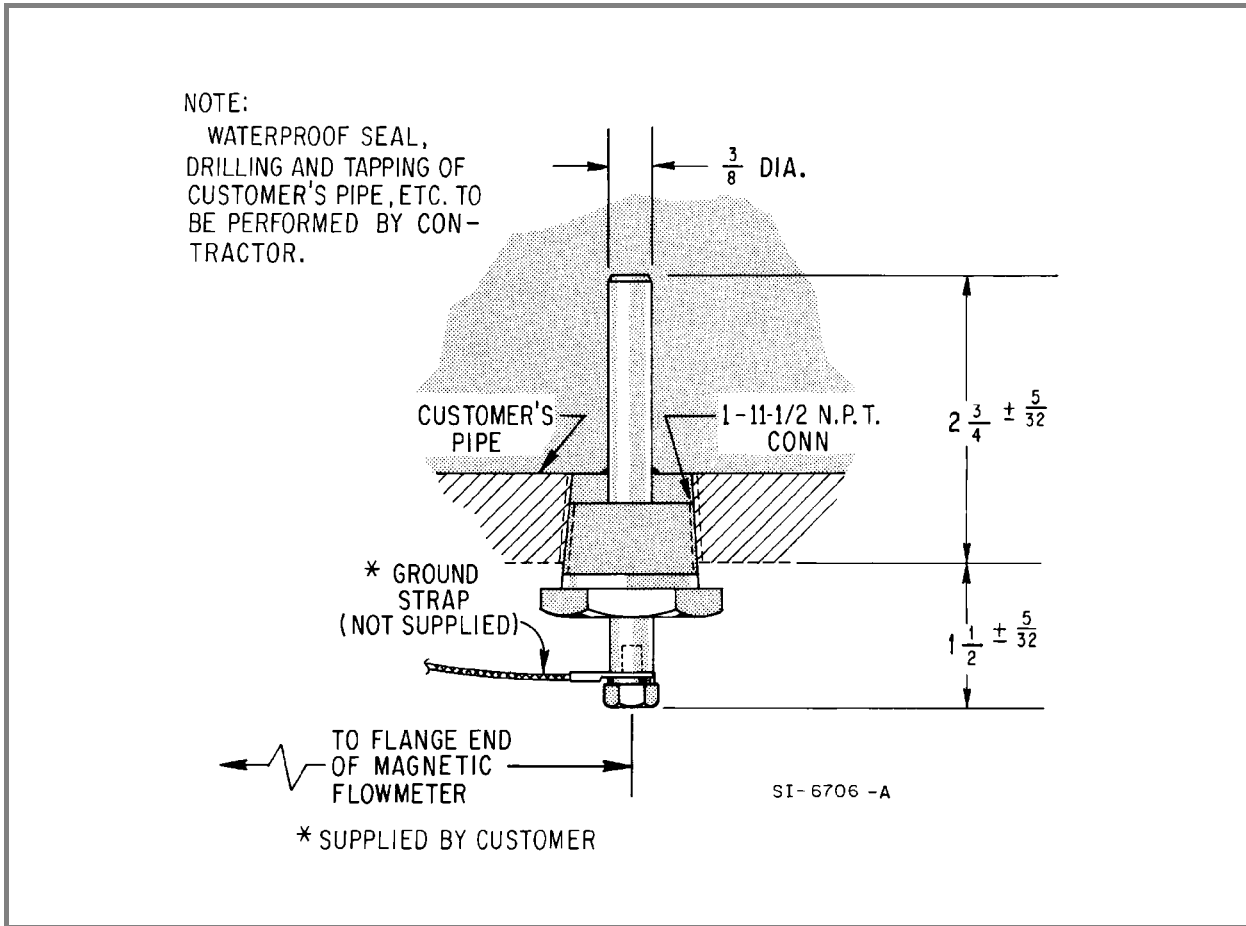

FIGURE 2-8. GROUNDING PROBE (OPTIONAL)

TABLE 2-3. GROUNDING PROBE PART NUMBERS

BASIC PART NUMBER	PROBE MATERIAL	PART NUMBER SUFFIX*			
		316 SS	Hastalloy C	Alloy 20	Hastalloy B
650B010__		T60	H20	V70	H10

* Add suffix to basic part number to complete the part number, e.g., 650B010H20 for a Hastalloy C Grounding Probe.

2.6 Electrical Interconnection

2.6.1 General

The Series 3000 MAG-X Magnetic Flowmeter is furnished with a remotely mounted Signal Converter. Interconnection details are contained in the Instruction Manual provided with the Signal Converter.

WARNING

ELECTRICAL SHOCK HAZARD. Equipment powered by ac line voltage constitutes a potential electric shock hazard to the user. Make certain that the system power input leads are disconnected from the operating branch circuit before attempting electrical interconnections.

Regardless of the interconnection procedure used, the grounding procedures given in Section 2.5 must be followed.

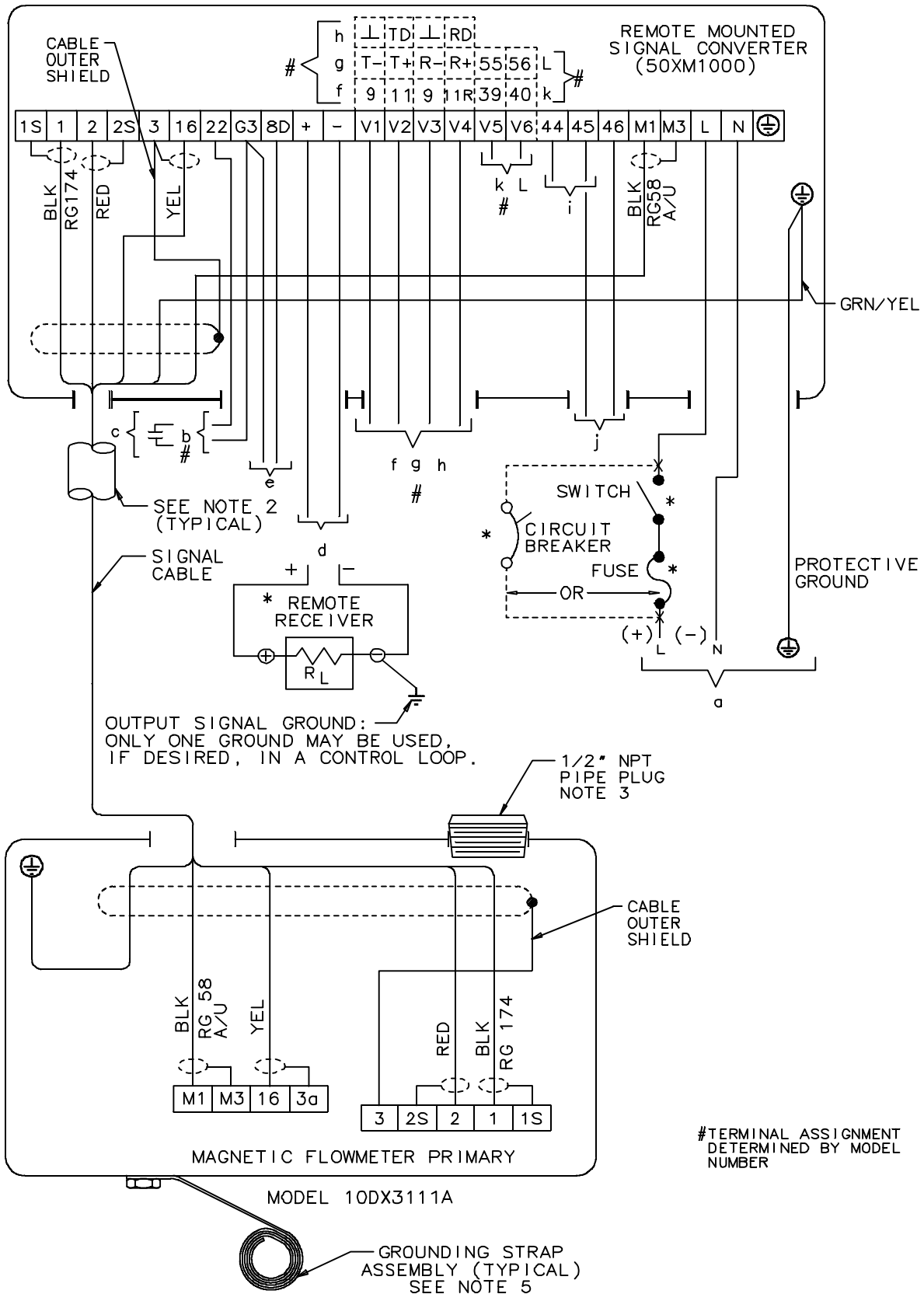

FIGURE 2-9. INTERCONNECTION DIAGRAM, MODEL 10DX3111A

TERMINAL ASSIGNMENT TABLE

- a) POWER SUPPLY - 120/240 V, 50/60 HZ, SINGLE PHASE OR 24 V dc. (AS SPECIFIED ON NAME PLATE)
NOTE: 240 V SUPPLY NOT FM APPROVED.
- b) MAY FUNCTION AS EITHER ZERO RETURN OR TOTALIZER RESET, AS SPECIFIED BY MODEL NUMBER.
- c) FIELD CONTACTS-IF USED AS ZERO RETURN FIELD CONTACTS TO CLOSE WHEN METER SUPPLY PUMP OR VALVE STOPS FLOW THRU METER. WHEN USED FOR TOTALIZER RESET, CONTACTS TO MOMENTARILY CLOSE TO INITIATE. TERMINALS 22 & G3 REMAIN OPEN IF NOT USED.
- d) OUTPUT SIGNAL = 4-20 mA
CURRENT OUTPUT R_L = <750 OHMS
- e) 0 TO 10 K Hz, ACTIVE TTL, 5m (15 FT) MAX CABLE LENGTH
- f) SCALED PULSE OUTPUT, ACTIVE, 24Vdc LOAD >150 OHMS
TERMINAL 9 & 11, FORWARD FLOW
TERMINAL 9 & 11R, REVERSE FLOW
- g) DATA LINK RS 485
- h) DATA LINK RS 232C
- i) REVERSE FLOW INDICATION - VIA RELAY CONTACT **
- j) FORWARD FLOW INDICATION ----SAME AS ABOVE
- k) ALARM CONTACT **
- l) OPTO COUPLED SCALED PULSE FORWARD - <10mA, <28Vdc.

NOTES:

1. * INDICATES SUPPLIED BY CUSTOMER.
2. ALL WIRING TO BE ENCLOSED IN METAL CONDUIT SUPPLIED BY CUSTOMER
3. UNUSED CONNECTIONS MUST BE PLUGGED TO MAINTAIN NEMA 4 RATING
4. ALL CONDUIT CONNECTIONS ARE 1/2" NPT.
5. METER GROUND BONDING STRAPS ARE USED TO PREVENT STRAY ELECTRICAL CURRENTS FROM PASSING THROUGH THE METERED LIQUID. SEE INSTRUCTION BULLETIN FOR DETAILS.
6. FOR HIGH TEMPERATURE APPLICATIONS (ABOVE 250° F) ENTIRE EXTERIOR OF METER BODY MUST BE INSULATED (EXCLUDING ELECTRONICS BOX MOUNTED ON EXTENSION NECK).

INSTALLATION REQUIREMENTS



THIS IS NONINCENDIVE EQUIPMENT WHICH IS SUITABLE FOR INSTALLATION IN CLASS I, DIVISION 2, GROUP A, B, C & D, HAZARDOUS (CLASSIFIED) LOCATIONS.



DO NOT DISCONNECT WIRING, REMOVE OR REPLACE COMPONENTS OR ASSEMBLIES WHILE CIRCUITS ARE ALIVE, UNLESS AREA IS KNOWN TO BE NONHAZARDOUS.

NON-HAZARDOUS LOCATION WIRING SHALL COMPLY WITH ANSI/NFPA 70, NATIONAL ELECTRICAL CODE, AND LOCAL CODE REQUIREMENTS.

CLASS 1, DIVISION 2 EQUIPMENT AND WIRING SHALL BE INSTALLED IN ACCORDANCE WITH ANSI/NFPA 70, ARTICLE 501.

THIS EQUIPMENT HAS "NONINCENDIVE CIRCUIT FIELD WIRING" CONNECTIONS IN ACCORDANCE WITH ANSI/ISA S12.12, FOR USE IN CLASS I AND II, HAZARDOUS (CLASSIFIED) LOCATIONS, ALLOWING ORDINARY LOCATION WIRING PER ANSI/NFPA 70, ARTICLES 501-4(b) EXCEPTION.

DEFINITIONS:

EQUIPMENT SUPPLYING ENERGY TO NONINCENDIVE CIRCUIT(S).

- V_{oc} = MAXIMUM OUTPUT VOLTAGE
- I_{sc} = MAXIMUM OUTPUT CURRENT
- C_a = MAXIMUM ALLOWABLE CAPACITANCE
- L_a = MAXIMUM ALLOWABLE INDUCTANCE

EQUIPMENT RECEIVING ENERGY FROM NONINCENDIVE CIRCUIT(S).

- V_{max} = MAXIMUM INPUT VOLTAGE
- I_{max} = MAXIMUM INPUT CURRENT
- C_i = MAXIMUM INTERNAL CAPACITANCE
- L_i = MAXIMUM INTERNAL INDUCTANCE

INTERCONNECTING FIELD WIRING.

- C_{cable} = TOTAL CABLE CAPACITANCE
- L_{cable} = TOTAL CABLE INDUCTANCE

NONINCENDIVE CIRCUIT FIELD WIRING PARAMETERS:

NOTE: NONINCENDIVE CIRCUIT FIELD WIRING PARAMETERS ONLY APPLY TO CIRCUIT TERMINALS IDENTIFIED BY A DOUBLE ASTERISK (**).

- ** CONTACT TERMINALS: V_{max} = 32.0 Vdc I_{max} = 110 mA
- C_i = 0 L_a = 0

EQUIPMENT SUPPLYING THESE CONTACTS SHALL BE FACTORY MUTUAL RESEARCH APPROVED, AND DESIGNATED AS "AIS" (ASSOCIATED INTRINSICALLY SAFE APPARATUS), OR "ANI" (ASSOCIATED NONINCENDIVE EQUIPMENT), AND SHALL HAVE:

$$V_{oc} < V_{max}, I_{sc} < I_{max}, C_a > C_{cable}, \text{ AND } L_a > L_{cable}$$

WHEN CABLE PARAMETERS ARE UNKNOWN, THE FOLLOWING VALUES MAY BE USED:

- CAPACITANCE (C_{cable}): 60 pF/ft (200 pF/m)
- INDUCTANCE (L_{cable}): 0.20 uH/ft (0.66 uH/m)

IT IS THE USERS RESPONSIBILITY TO VERIFY THE SUITABILITY OF ALL EQUIPMENT AND WIRING FOR USE IN A CLASS 1, DIVISION 2, HAZARDOUS (CLASSIFIED) LOCATION.

FIGURE 2-9. INTERCONNECTION DIAGRAM, MODEL 10DX3111A

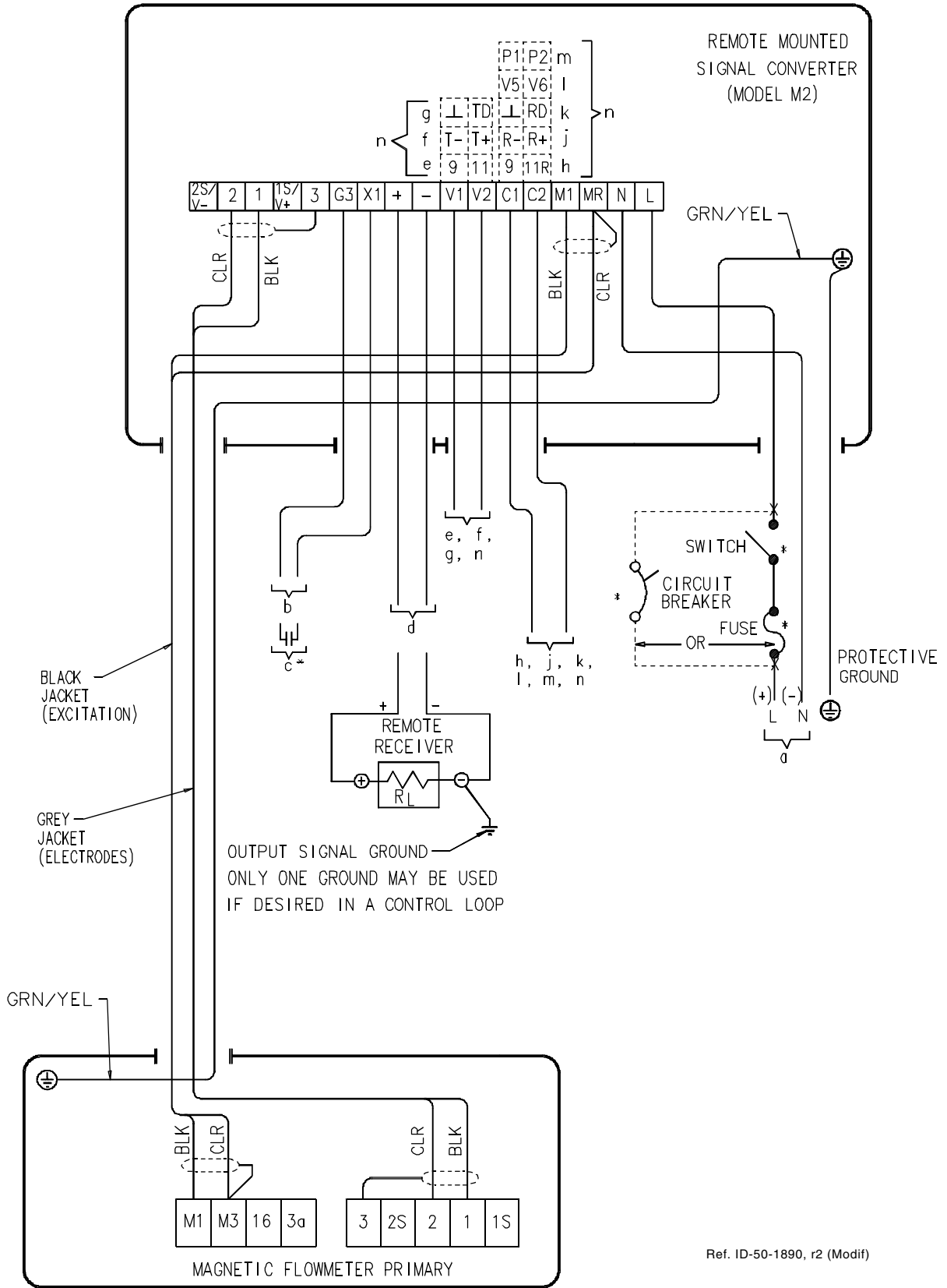

Ref. ID-50-1890, r2 (Modif)

FIGURE 2-10. INTERCONNECTION DIAGRAM, MODEL 10DX3111G

TERMINAL ASSIGNMENT TABLE

- a) POWER SUPPLY - 120/240 V, 50/60 HZ, SINGLE PHASE
OR 24 V dc, (AS SPECIFIED ON NAME PLATE)
- b) MAY FUNCTION AS EITHER ZERO RETURN OR TOTALIZER RESET,
AS SOFTWARE SELECTED
- c) FIELD CONTACTS-IF USED AS ZERO RETURN FIELD CONTACTS TO
CLOSE WHEN METER SUPPLY PUMP OR VALVE STOPS FLOW THRU METER.
WHEN USED FOR TOTALIZER RESET, CONTACTS TO MOMENTARILY
CLOSE TO INITIATE. TERMINALS X1 & G3 REMAIN OPEN IF NOT USED.
- d) OUTPUT SIGNAL - 4-20 mA
CURRENT OUTPUT R_L - <750 OHMS
- e) SCALED PULSE OUTPUT, ACTIVE, 24Vdc; LOAD >150 OHMS
TERMINAL 9(COM) & 11, FORWARD FLOW
- f) DATA LINK RS 485 TRANSMIT
- g) DATA LINK RS 232C TRANSMIT
- h) SCALED PULSE OUTPUT ACTIVE, 24 Vdc; LOAD >150 OHMS
TERMINALS 9(COM) & 11R, REVERSE FLOW
- j) DATA LINK, RS485 RECEIVE
- k) DATA LINK, RS232C RECEIVE
- l) OPTO COUPLED ALARM CONTACT <10mA, <28 Vdc
- m) OPTO COUPLED MULTI-FUNCTIONAL CONTACT <10mA, <28Vdc
- n) TERMINAL NUMBER ASSIGNMENT DETERMINED BY MODEL NUMBER

NOTES:

- 1. *INDICATES SUPPLIED BY CUSTOMER.
- 2. ALL WIRING TO BE ENCLOSED IN METAL CONDUIT
SUPPLIED BY CUSTOMER
- 3. UNUSED CONNECTIONS MUST BE PLUGGED TO
MAINTAIN NEMA 4 RATING
- 4. ALL CONDUIT CONNECTIONS ARE 1/2" NPT.
- 5. METER GROUND BONDING STRAPS ARE USED TO PREVENT
STRAY ELECTRICAL CURRENTS FROM PASSING
THROUGH THE METERED LIQUID. SEE INSTRUCTION
BULLETIN FOR DETAILS.
- 6. FOR HIGH TEMPERATURE APPLICATIONS (ABOVE 250° F)
ENTIRE EXTERIOR OF METER BODY MUST BE INSULATED
(EXCLUDING ELECTRONICS BOX MOUNTED ON EXTENSION NECK).
- 7. GREY JACKETED ELECTRICAL SIGNAL CABLE IS BELDEN
TYPE 8762, BLACK JACKETED EXCITATION CABLE HAS
THE SAME CONSTRUCTION AS BELDEN 8762.

INSTALLATION REQUIREMENTS



APPROVED

THIS IS NONINCENDIVE EQUIPMENT WHICH IS SUITABLE FOR INSTALLATION IN CLASS I,
DIVISION 2, GROUP A, B, C & D, HAZARDOUS (CLASSIFIED) LOCATIONS.



WARNING

DO NOT DISCONNECT WIRING, REMOVE OR REPLACE COMPONENTS
OR ASSEMBLIES WHILE CIRCUITS ARE ALIVE, UNLESS AREA IS
KNOWN TO BE NONHAZARDOUS.

NON-HAZARDOUS LOCATION WIRING SHALL COMPLY WITH ANSI/NFPA 70, NATIONAL
ELECTRICAL CODE, AND LOCAL CODE REQUIREMENTS.

CLASS I, DIVISION 2 EQUIPMENT AND WIRING SHALL BE INSTALLED IN ACCORDANCE
WITH ANSI/NFPA 70, ARTICLE 501.

THIS EQUIPMENT HAS *NONINCENDIVE CIRCUIT FIELD WIRING* CONNECTIONS IN
ACCORDANCE WITH ANSI/ISA S12.12, FOR USE IN CLASS I AND II,
HAZARDOUS (CLASSIFIED) LOCATIONS, ALLOWING ORDINARY LOCATION WIRING
PER ANSI/NFPA 70, ARTICLES 501-4(b) EXCEPTION.

Ref. ID-50-1890, r2 (Modif)

FIGURE 2-10. INTERCONNECTION DIAGRAM, MODEL 10DX3111G

3.0 OPERATION and START-UP

The ABB Automation Series 3000 Magnetic Flowmeter is precision calibrated at the factory for the values stated on the instrument tag. If specific values were not specified, the meter is calibrated at some nominal maximum flow rate and for a 4-20 mA current output span. In either case, the calibration data is noted on the instrument data tag as shown in Figure 3-1.

There are no operating controls that require field adjustment unless the full scale range setting was not specified. If a change in the full scale range setting is required, refer to the Instruction Bulletin supplied with the Signal Converter. If no change is required, the equipment is ready for operation as received.

Prior to initial system start up, verify that the meter is properly installed; check flow direction, wiring interconnection and grounding as discussed in Section 2.0 Installation. Particular attention should be paid to the meter grounding procedures; improper grounding may result in unsatisfactory performance.

Start flow through the process piping system that includes the meter. Allow a nominal flow through the pipeline for several minutes to purge entrapped air. The pipeline must be full for accurate flow measurement.

Apply power to the Magnetic Flowmeter by closing the external switch or circuit breaker; there are no switches inside of the equipment. Also energize any auxiliary equipment associated with the flow metering system, such as remote analog recorders, controllers or rate indicators.

Initiate process flow through the pipeline. Flow measurement and concurrent output signal transmission will commence with flow through the meter. Information concerning operation of the Signal Converter is provided in the Instruction Bulletin supplied with the Converter.

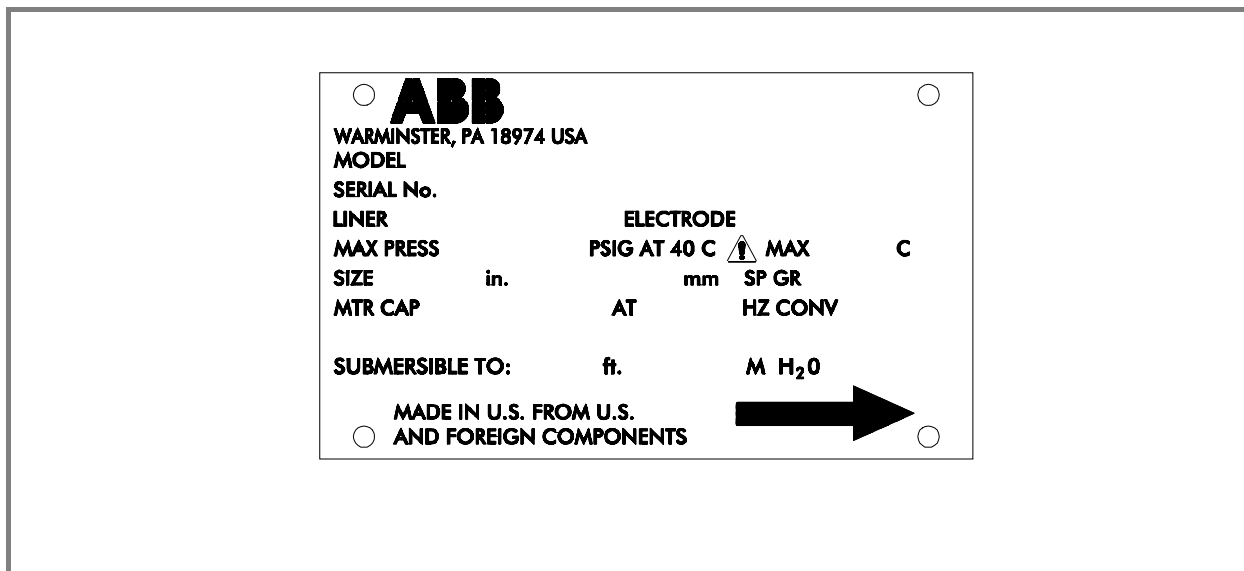

FIGURE 3-1. TYPICAL INSTRUMENT TAG

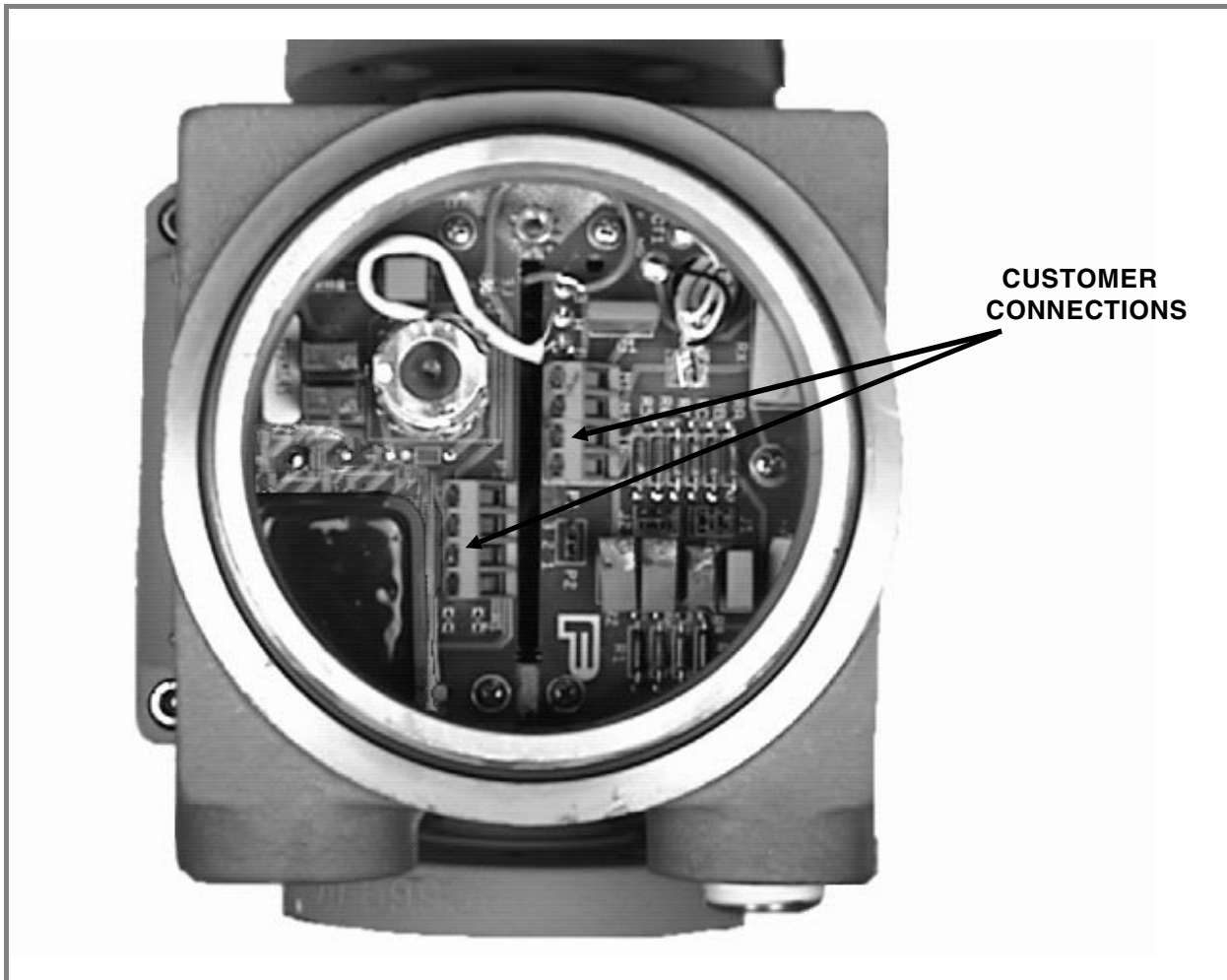

FIGURE 3-2. CONTINUOUS SUBMERGENCE PRIMARY CONNECTIONS FOR REMOTE MOUNTED SIGNAL CONVERTER

Note: Figure shows electronics without encapsulation material. Normally the converter housing is filled with a silicone rubber encapsulant.

4.0 FUNCTIONAL DESCRIPTION

The Magnetic Flowmeter body houses two signal electrodes and the flux producing magnet coils, as shown pictorially in Figure 4-1. Normally, the meters have their primary interconnection wiring terminated at a printed circuit assembly located in the base of the meter housing. A cable connects the Primary meter housing to the remote Signal Converter. This interconnection wiring is shown in Figures 2-9 & 2-10 for Models 10DX3111A & 10DX3111G respectively.

The primary provides two output signals to the associated Signal Converter:

- an electrode signal that contains the flow rate information
- the reference signal which is proportional to the magnet excitation current (This reference signal is proportional to the flux density in the metering section.)

The reference voltage is derived across a precision "constant meter factor" resistance network that is connected in series with the magnet coils. Changes in magnet drive voltage, which cause a variation of flow signal, will simultaneously cause a proportional variation of the reference voltage. The circuitry will provide an exact ratio and thereby provide immunity to power supply variation. The magnet coil drive circuitry is contained in the Signal Converter. A detailed discussion of primary meter operation is provided in Chapter 5.0, Circuit Description.

4.1 Basic Operating Principle

4.1.1 Signal Voltage Generation

The operating principle of the ABB Automation Series 3000 Magnetic Flowmeter is based upon Faraday's Law of Induction which states that the voltage induced across any conductor as it moves at right angles through a magnetic field will be proportional to the velocity of that conductor. This principle finds common application in direct and alternating current generators. Essentially, the ABB Automation Magnetic Flowmeter constitutes a modified form of an ac generator.

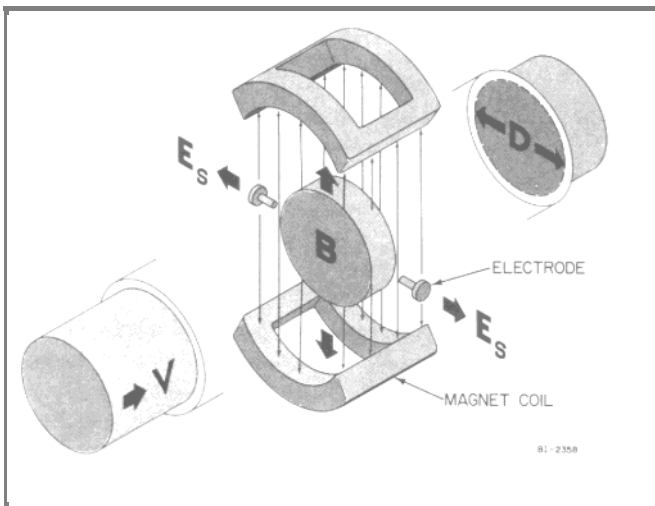

Figure 4-1 graphically illustrates the basic operating principle. A magnetic field, "B", being generated in a plane which is perpendicular to the axis of the meter pipe. A disk of the metered liquid can be considered as a conductor. The transverse length "D" is equal to the meter pipe diameter. Since the velocity "V" of the liquid disk is directed along the axis of the meter pipe, a voltage, signal "Es", will be induced within this liquid which is mutually perpendicular to the direction of the liquid velocity and the flux linkages of the magnetic field; i.e., in the axial direction of the meter electrodes.

FIGURE 4-1. BASIC OPERATING PRINCIPLE

This electrode voltage is the summation of all incremental voltages developed within each liquid particle that passes under the influence of the magnetic field.

This may be expressed mathematically as:

(Equation #1)

$$E_s = \frac{1}{\alpha} BDV$$

where:

- E_s = induced electrode voltage
- B = magnetic field strength
- D = meter pipe diameter
- α = dimensionless constant
- V = liquid velocity

Thus, the metered liquid constitutes a continuous series of conductive liquid disks moving through a magnetic field. The more rapid the rate of liquid flow, the greater the instantaneous value of signal voltage as monitored at the meter electrodes.

4.1.2 Magnet Coil Drive Circuits

In many conventional Magnetic Flowmeters the integral magnet coils are driven directly by the customer's 50/60 Hz power service. Notably, however, the design of the ABB Automation Series 3000 Magnetic Flowmeter uses magnet drive circuits which are alternately energized bi-directionally at a low frequency rate as commanded by the associated Converter/Driver electronics.

4.1.3 Volumetric Flow Rate Measurement

The ABB Automation Magnetic Flowmeter is a volumetric flow rate measuring instrument. This can be shown by substituting the physical equivalent of liquid velocity into equation #1 as follows:

(Equation #2)

$$V = \frac{Q}{A} = \frac{4Q}{\pi D^2}$$

Substituting for V in equation #1

$$E_s = \frac{1}{\alpha} BD \frac{4Q}{\pi D^2}$$

and solving for Q:

$$\therefore Q = \frac{\pi \alpha D^2}{4} \cdot \frac{E_s}{B}$$

Since $B = \beta E_r$

and since α , D and β are constant:

(Equation #3)

$$Q = \gamma \frac{E_s}{E_r}$$

where:

- Q = volumetric flow rate
- A = cross-sectional area
- D = pipe section diameter
- E_s = induced signal voltage
- E_r = reference voltage
- B = magnetic flux density
- α = dimensionless constant
- β & γ = dimensional constant
- V = liquid velocity

Therefore, volumetric flow rate is directly proportional to the induced signal voltage as measured by the ABB Automation Magnetic Flowmeter.

4.2 Operating Characteristics

4.2.1 Liquid Variables

4.2.1.1 Liquid Conductivity

The Magnetic Flowmeter requires a liquid conductivity of 5 microsiemens per centimeter or higher for operation. This minimum liquid conductivity requirement is not affected by the length of the signal interconnection cable when remote mounting of the Signal Converter is required, as long as the ABB Automation supplied interconnection cable (with driven shields) is utilized. The nominal maximum transmission distance is limited to 200 feet (60 meters); however standard cable length is 50 feet (15 m) unless otherwise specified.

The conductivity of a given liquid, σ, may be determined experimentally under a filled meter condition, as follows:

- 1) Remove the Converter housing cover. Disconnect the electrode signal interconnection leads from terminals "1" and "2" of the Signal Converter. (These leads should be identified so that they will be properly reconnected.)
- 2) Measure the resistance between signal leads "1" and "2" with an ac ohmmeter.

CAUTION
Do not use a dc ohmmeter for this measurement as polarization effects will produce completely erroneous data.

The conductivity of the process liquid (in microsiemens/cm) may be determined from the electrode ac resistance measurement (in megohms) by substitution of values in the following equation.

$$\sigma = \frac{1}{(R_{ac} - 0.072) \times \text{Electrode Dia, in cm}}$$

where,

0.072 is the electrode barrier resistance in megohms; i.e., $36 \text{ k} \times 2/10^6$

and,

typical electrode diameter is 0.375" (0.952 cm)

For example, assuming the measured ac electrode resistance (full pipe and zero flow) is 192,000 ohms and electrode diameter is 0.952 cm, then

$$\sigma = \frac{1}{(0.192 - 0.072) \times 0.952} = 8.75 \mu\text{s/cm}$$

This is above the threshold for specified measurement accuracy for the particular liquid, meter size and Signal Converter combination. Liquid conductivities at the operating temperature may also be determined from standard reference works for many pure liquids. ABB Automation Field Engineers are equipped to determine the conductivities of special liquids at the user's site as an engineering service.

4.2.1.2 Liquid Temperature

Having established the minimum liquid conductivity requirements for a given application, any liquid which exhibits equal or higher conductivity may be metered without concern for any system compensating adjustments. However, due regard for the effect of the liquid conductivity versus temperature should be considered.

Most liquids exhibit a positive temperature coefficient of conductivity. It is possible for certain marginal liquids to become sufficiently non-conductive at lower temperatures so as to hamper accurate metering; whereas, the same liquid at higher or normal environmental temperatures may be metered with optimum results. The possibility of an adverse temperature conductivity characteristic should be investigated before attempting to meter such a liquid. Liquid or ambient temperatures are also limited by the meter materials specification.

Other normal effects of temperature, such as influence upon liquid viscosity and density, the size of the metering area, and the flux density of the magnetic field, have negligible or no effect upon metering accuracy.

4.2.1.3 Other Liquid Variables

Other liquid variables such as viscosity, density and liquid pressure have no direct influence on metering accuracy. Liquid density has no effect on volumetric flow rate since only the area of the meter pipe and liquid velocity are required to determine the rate of flow. Viscosity and metering pressure are restricted to physical limitations alone, such as the leakage pressure of the meter pipe flange connections.

4.2.2 Metering Characteristics

The metering pipe must be completely filled at all times for accurate results. Where there is possibility of operation with a partially filled horizontal pipeline, it is recommended that the Magnetic Flowmeter be installed in a vertical section of that pipeline such that liquid flow moves upward. A vertical installation also offers the advantage of an even distribution of liner wear in the event that solid abrasives are being carried along in the liquid stream. See Figure 2-4 for recommended meter installation orientations.

The ABB Automation Magnetic Flowmeter will measure the total amount of material passing in the liquid stream. The meter will not, for instance, differentiate between the amount of liquid and the amount of entrained gases. Also, in the case of a slurry, it will not differentiate the amount of liquid from solids. If the liquid to mixant ratio is of importance to process control, then separate measurements of the concentration of the desired medium must be made and appropriate correction factors must be applied to the Magnetic Flowmeter output.

In applications involving variable quantities of uniformly dispersed, non-conductive mixing agents, it must be determined that the higher concentrations of mixant will not drive the average conductivity of the liquid mixture below the minimum conductivity level for the given installation.

5.0 CIRCUIT DESCRIPTION

Flowmeters of the pulsed DC type operate on the principle that unwanted electrode signals occur while the magnetic flux is changing. Accordingly, the signal converters have been designed to capture the electrode voltage only during that portion of the excitation cycle when the magnetic flux is constant. This interval occurs during the last 25% of each half excitation cycle. By using sampling techniques, the flow (differential mode) signal is measured only during the intervals that magnetic flux is constant.

$$\left(\frac{d\Phi}{dt} = 0 \right)$$

Therefore, zero-instability due to changing flux is eliminated by use of the MAG-X design concept (sampling technique), providing a meter totally free of zero drift. Pulsed DC operation of a magmeter system eliminates those variables capable of causing drift of the meter zero point. A thorough discussion of Signal Converter operation is provided in the Instruction Manual supplied with the particular Signal Converter.

Models 10DX3111A & G flanged flowmeter primaries contain two flux producing coils wired in series and a pair of diametrically opposed electrodes mounted at 90 degrees to the coil flux plane (refer to FIGURE 5-1 below). Meter coils are excited with approximately ± 10 volts of pulsed DC. A precision current sensing network is connected in series with the coils. The current sense network produces what ABB Automation refers to as a "Reference Voltage", which is typically ± 70 millivolts. The reference voltage is directly proportional to the strength of the magnetic field in the measuring tube and is measured by the signal converter. The reference voltage must be measured, since any variation in reference voltage will also produce a proportional change in electrode signal voltage, assuming an unchanged flow velocity. The current sense (reference network) may be in the Primary or the Secondary, depending on the model number and/or the design level.

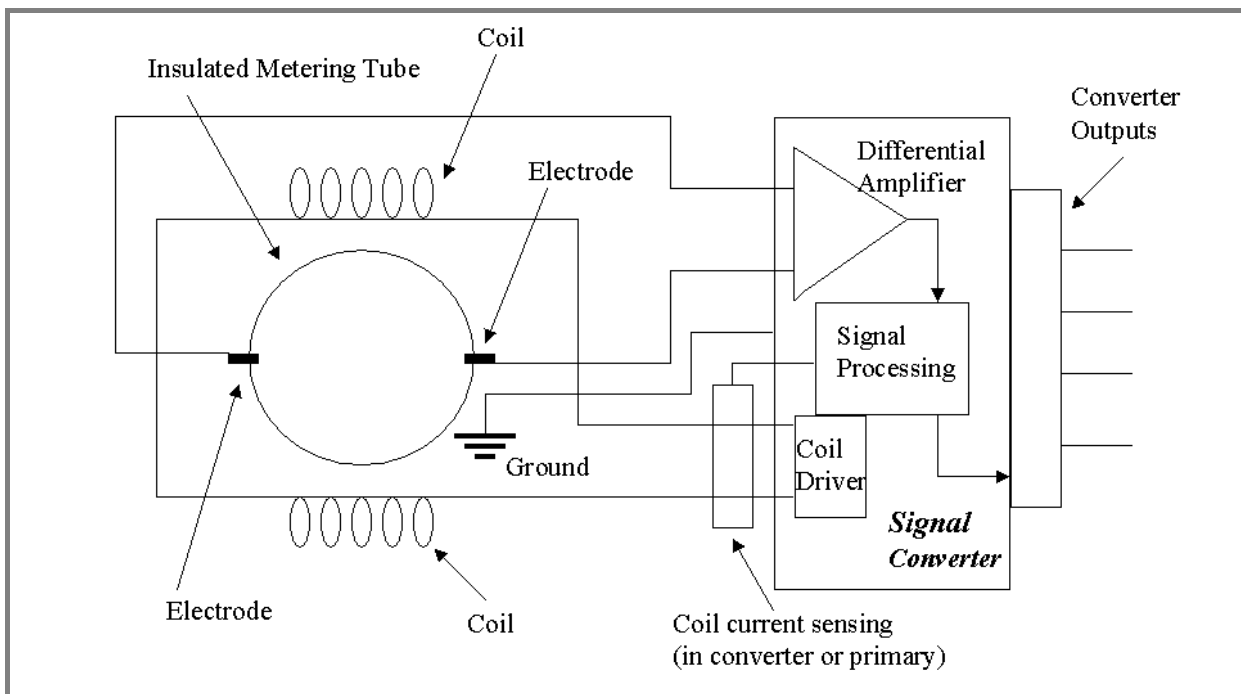

FIGURE 5-1. SIMPLIFIED MAGMETER SYSTEM BLOCK DIAGRAM

5.1 Wiring Diagrams

All Flowmeter intraconnection wiring is terminated at the CMC & ZERO PC board assemblies located in the base of the meter housing.

The CMC & ZERO PC Assemblies provide several functions. These include:

1. Establishing interconnections between the Flowmeter internal wiring and the Signal Converter.
2. Permitting factory adjustment of meter capacity values to a fixed value for each nominal size Flowmeter.
3. Permitting factory adjustment of Flowmeter zero.
4. Establishing proper wiring connections for remotely mounted Signal Converters.

The Flowmeter provides two output signals to the associated Signal Converter:

- an electrode signal that contains the flow rate information
- a signal which is proportional to the magnet excitation current

Model 10DX3111A Primary provides a reference signal to the Converter via the magnet coil drive circuitry, as discussed above. In Model 10DX3111G, the magnet coil drive circuitry is contained in the M2 Signal Converter and the reference signal is produced in the remote Converter. Internal wiring diagrams are shown in Figures 5-1 and 5-2 respectively.

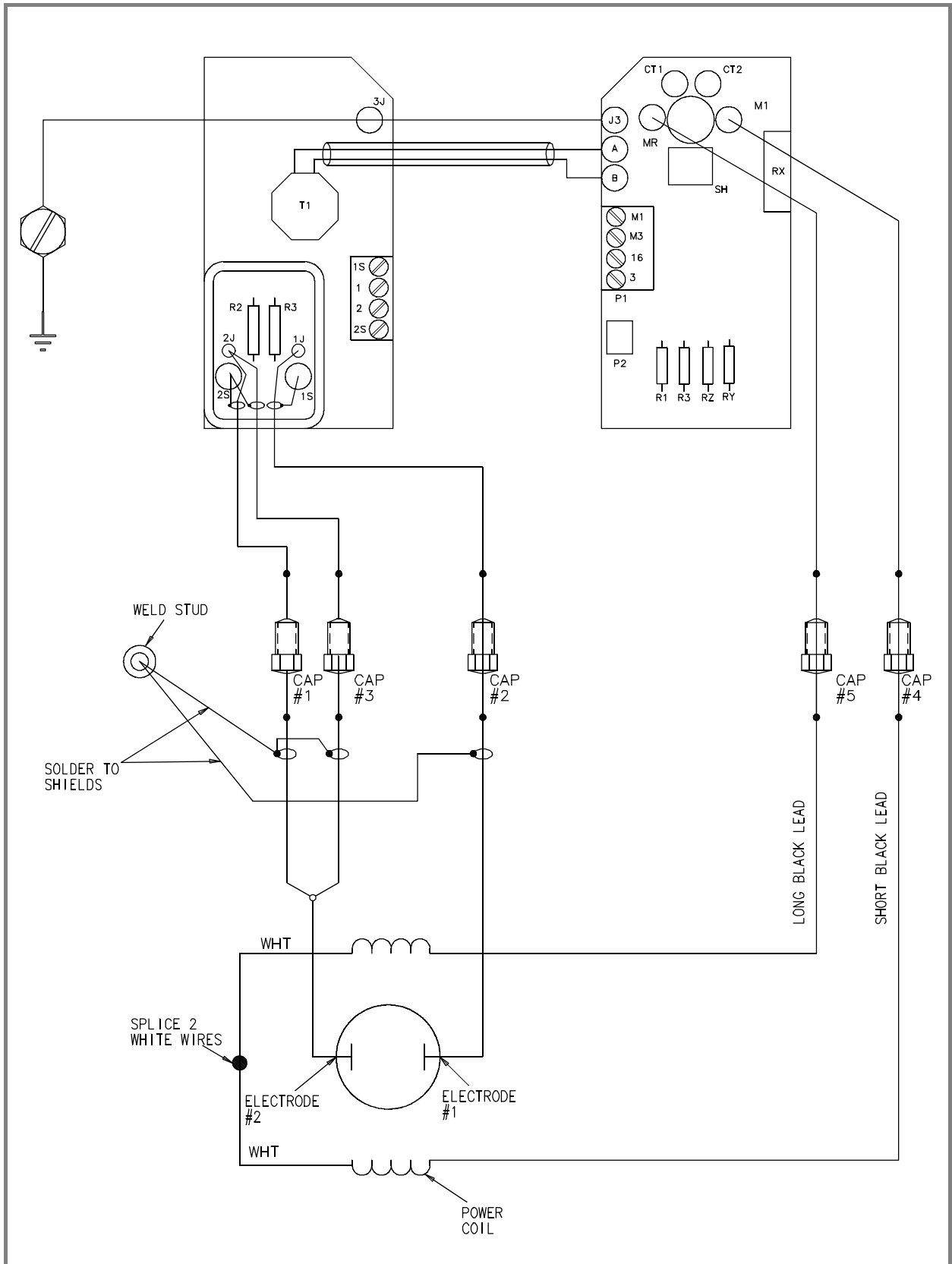

FIGURE 5-2. INTERNAL WIRING DIAGRAM, MODEL 10DX3111A

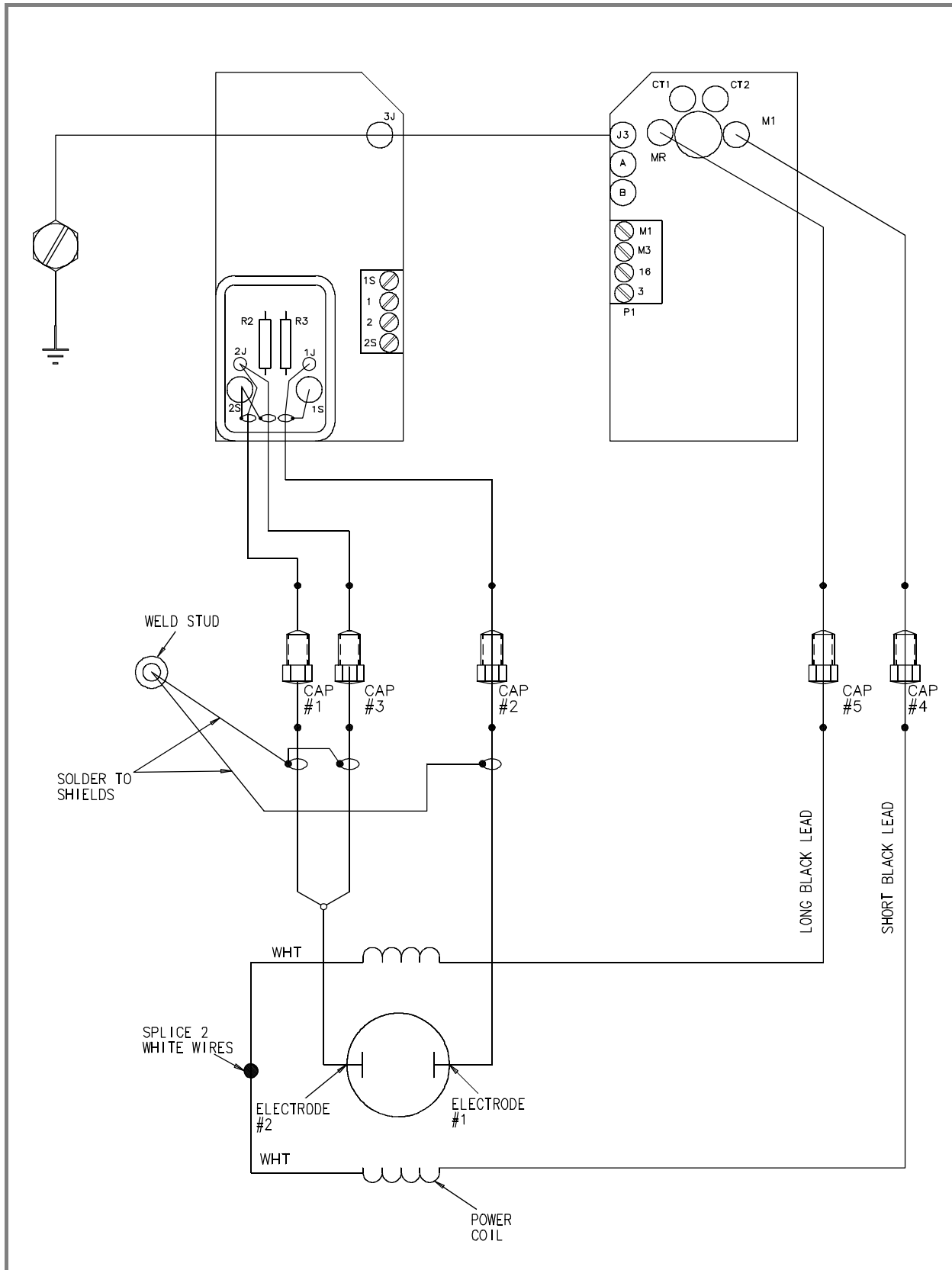

FIGURE 5-3. INTERNAL WIRING DIAGRAM, MODEL 10DX3111G

6.0 MAINTENANCE

6.1 General

Except for an occasional performance verification check, there is no required routine maintenance for the Series 3000 Magnetic Flowmeter. For practical reasons it is suggested that the meter body not be disassembled. If disassembled, complete waterproof sealing is required for satisfactory operation and is best done at the factory. Replacement of faulty magnet drive coils and electrode replacement is a factory operation. Factory calibration after this type of repair is the only way to guarantee meter accuracy.

ABB Automation offers a Repair/Exchange Program to facilitate replacement of a defective meter or Converter. If the equipment is beyond the warranty limit, under this program a fixed price will be charged for replacement of defective equipment, with appropriate credit issued when the repairable unit is received by ABB Automation (charges prepaid). The equipment available under this program is as follows:

- the complete meter including remote Signal Converter
- the meter and associated primary board; that is, the hydraulic portion without the Signal Converter
- the remote Signal Converter

WARNING

All Flowmeters and/or Signal Converters being returned to ABB Automation for repair must be free of any hazardous materials (acids, alkalis, solvents, etc.). A Material Safety Data Sheet (MSDS) for all process liquids must accompany returned equipment. Contact ABB Automation for authorization prior to returning equipment.

NOTE

Operation and maintenance procedures for the Signal Converter are provided in the Instruction Bulletin supplied with the Signal Converter.

When communicating with ABB Automation regarding replacement of a complete meter (including the Converter), the meter body, or the Signal Converter, it is important to refer to the complete instrument serial number to assure that the correct replacement will be supplied. This information is provided on the manufacturing specification sheet supplied with the Magnetic Flowmeter, and on the instrument data tag.

CAUTION

Some of the IC devices used in the Signal Converter are static sensitive and may be damaged by improper handling. When adjusting or servicing the Signal Converter, use of a grounded wrist strap is recommended to prevent inadvertant damage to the integral solid state circuitry.

6.2 System Troubleshooting

If the Magnetic Flowmeter doesn't appear to be operating properly, the following procedure can be used as a guide to isolate the malfunctioning device to either the primary meter or the Signal Converter. A standard multimeter and an oscilloscope are suitable for making most of the test measurements.

To supplement the following discussion refer to:

- Section 5.0 Circuit Description
- Applicable Signal Converter Instruction Bulletin

NOTE

The Series 3000 Magnetic Flowmeter housing is supplied as a sealed unit. Therefore, customer field repairs to these meters are not recommended. In the event of a malfunction, repairs should only be performed by an ABB Automation field service engineer, or the complete meter returned (shipping charges prepaid) to ABB Automation for service.

WARNING

ELECTRICAL SHOCK HAZARD. Equipment powered by an AC line voltage presents a potential electric shock hazard. Servicing of the Magnetic Flowmeter or Signal Converter should only be attempted by a qualified electronics technician.

1. If the magnetic flowmeter does not appear to be operating properly, proceed as follows:
 - a) Remove access covers from the junction box and the Converter housing.
 - b) Inspect for evidence of water entry in the junction box and Converter housing.

If water is present in either the junction box or converter housing of the flowmeter, immediately de-energize system power to eliminate the possibility of a shock hazard.

The presence of water in either the converter housing or the terminal box on the remote primary most often results in irreparable damage to the circuit board assemblies inside. If such damage is evident, the meter should be removed from the process pipeline and returned to ABB Automation for repair. It is also important that the source of the water-entry be found so that the situation doesn't reoccur when the meter is placed back into service.

Should water be found inside the wiring compartment of a Converter housing, the circuit board assembly in this section may be replaced in the field (Consult the factory for additional instructions if this procedure becomes necessary).

2. Since signal wiring and operating procedures depend on the type of Converter and the mounting option selected, the user should refer to the instruction bulletin supplied with the associated Signal Converter for system troubleshooting procedures. A static performance test for the primary mounted components is discussed in Section 6.3.

The Signal Converter options available for use with the Magnetic Flowmeter are:

- remotely mounted 50XM1000N Microprocessor-based Signal Converters
- remotely mounted M2 Microprocessor-based Signal Converter

3. Possible causes of erroneous flow rate indication are:

- incorrect grounding
- excessive noise due to a heavy slurry process or a non-homogeneous process
- loose or intermittent wiring
- non-full or empty meter pipe
- excess air entrained in process liquid
- fluid conductivity below specified minimum

6.3 Static Test

If the Magnetic Flowmeter does not appear to be operating properly, the following resistance measurements can be made to establish whether an electrical malfunction has occurred. An analog multimeter is required for checking the electrodes. Either an analog or digital multimeter can be used for checking the coils. These measurements can be made at the flowmeter PC board.

WARNING
ELECTRICAL SHOCK HAZARD. Equipment powered by an ac line voltage presents a potential electric shock hazard. Make certain that the system power is disconnected before making the following ohmmeter checks.

6.3.1 Magnet Coil Check

6.3.1.1 Model 10DX3111A

Verify that the system power service has been de-energized. Measure the resistance between terminals M1 & MR on the Primary connection board. The indicated resistance reading should be within the ranges shown in TABLE 6-1. A reading significantly outside this range or a short circuit between leads indicates defective coil(s).

Next, unsolder the M1 and MR wires from the Primary connection circuit board. Measure the resistance from each of these wires to the flowmeter body. Resistance from either of these leads to the body should be greater than 5 M Ω . A low resistance reading may indicate that moisture has entered the meter interior. Re-solder the M1 & MR wires to the circuit board when this step has been completed.

Measure the resistance between terminal 16 of the Primary connection board and the flowmeter body. This resistance should measure between 10 Ω and 500 Ω .

6.3.1.2 Model 10DX3111G

Verify that the system power service has been de-energized. Measure the resistance between terminals M1 & MR on the Primary connection board. The indicated resistance reading should be within the ranges shown in TABLE 6-1. A reading significantly outside this range or a short circuit between leads indicates defective coil(s). Next, disconnect the the field wiring to the M1 and MR terminals. Measure the resistance from each of these primary terminals to the flowmeter body. Resistance from either of these leads to the body should be greater than 5 MΩ. A low resistance reading may indicate that moisture has entered the meter interior. If the measured resistance is within specifications, reconnect the wires to the terminal block.

TABLE 6-1. METER COIL RESISTANCE

METER SIZE		COIL RESISTANCE (Nominal, ohms)
mm	inches	Series Resistance
350	14	21.2
400	16	19.2
450	18	18.6
500	20	18.6
600	24	19.0

If readings in this section are not within specification, the Signal Converter may display a "**U-ref too low**" error message.

6.3.2 Electrode Check

The electrode check is essentially a resistance measurement that can be made to establish that a short (or high resistance leakage path) does not exist between one, or both, electrodes and the meter body. **Verify that the system power service has been de-energized.**

To thoroughly test the electrodes of the flowmeters, the meters must be tested under both full and empty pipe conditions. If this is not possible, it may still be helpful to perform one of the tests since useful partial information may be gained from the results of either portion of the test.

6.3.2.1 Full Pipe Test

The wetted electrodes of all flowmeters manufactured in accordance with FM Div.1 or Div.2 requirements must have energy-limiting resistance placed in series with them. Depending on the model being tested, the nominal resistance value is 100,000 ohms and will add to any resistance measured between the wetted electrode and the fluid in contact with that electrode.

Electrode full pipe measurements should be made with the ohmmeter placed on its highest range. An AC type ohmmeter (i. e. conductivity bridge) is preferred because DC voltage will tend to polarize the electrode (but will nevertheless provide meaningful information). Connect the ohmmeter positive lead first to electrode terminal "1" and then to electrode terminal "2" with the negative lead to terminal "3" or the flowmeter body. The measured resistance should be 100,000 ohms plus the intrinsic resistance between electrode and fluid (typically 50,000 additional ohms or less). If using a DC ohmmeter, the resistance between the electrode and the fluid will tend to increase as the electrode becomes polarized by a DC signal. This effect is normal. AC resistance readings will not vary once established. Readings greater than 150,000 ohms may indicate a coated electrode. Infinite readings indicate a broken connection in the electrode wiring path. Meters with infinite full pipe readings should be returned to the factory for repair.

6.3.2.2 Empty Pipe Test

If possible, the pipeline should now be drained and the flowmeter should be given a few minutes to allow the fluid to drain off the electrode to liner interface. Connection of either a DC or AC ohmmeter between electrode terminals "1" or "2" and the meter body (terminal "3") should result in a reading greater than 5 M Ω . Lower readings indicate either that process fluid has leaked behind the electrode or that moisture has entered the flowmeter housing. If this is the case, the defective meter should be returned to the factory for repair.

6.3.2.3 Electrode Voltage Test

If no erroneous readings are found when the electrode resistance test is performed, an additional test may be performed with the system powered and the field wiring restored. Use a digital voltmeter, with a range-setting of 20VDC, to measure the voltage between electrode terminals 1 & 3 (common) and between electrode terminals 2 & 3. The voltage readings should be between ± 10 mV and ± 2 VDC and should not differ by more than 0.4 VDC. If measured voltages are outside of these ranges, it may indicate that an electrode is open, shorted or that the process fluid is non-conductive.

If the results of the procedures in Sections 6.3.2.1 through 6.3.2.3 indicate normal meter parameters, the flowmeter may be returned to service.

Refer to the instruction bulletin supplied with the Signal Converter for additional advice on troubleshooting flowmeter electronics.

7.0 PARTS LIST

7.1 Basic Meter Parts

The Basic Meter Parts List is cross referenced by symbol number to Figure 7-1 below. Separate figures and parts lists are provided for the electronics housing and for the electrode assemblies.

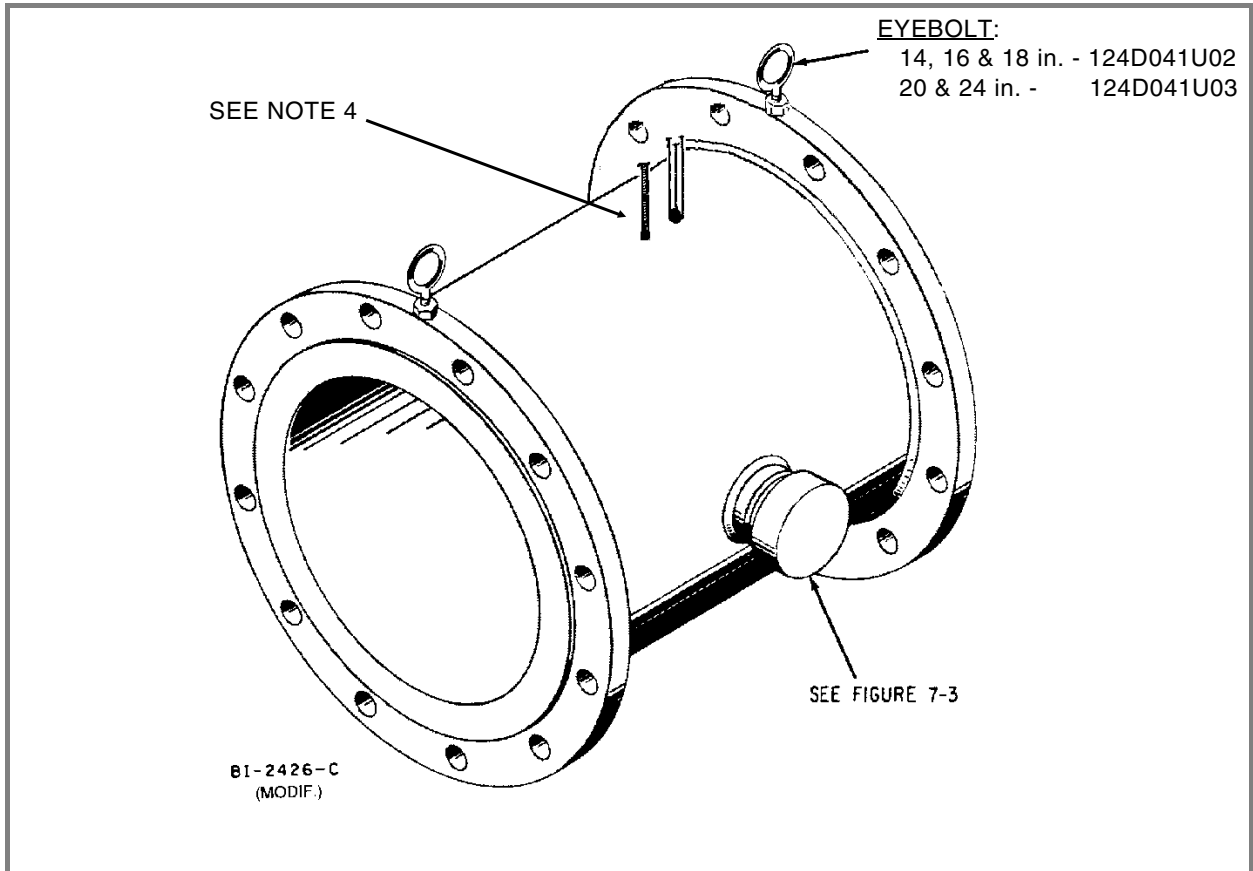

FIGURE 7-1. BASIC FLOWMETER CONSTRUCTION

NOTES:

1. The meter body is not a field repairable item. In the event of failure of the meter's internal components, such as magnet coils or electrode wiring, the flowmeter must be returned to ABB Automation for repair. All correspondence should reference the complete meter model number and serial number.

2. Refer to the Instruction Bulletin supplied with the Signal Converter for the applicable replacement part number. ABB Automation maintains a repair/exchange program for this assembly; simply add "RE" to the part number given in the IB Parts List. For example:

Model 50XM1000N = PN CD674A498U50RE

3. Mounting gaskets and hardware must be selected according to meter size.

4. Meter body wiring is shown without the electronics housing weldment for clarity. Electronics Housing parts are shown in Figure 7-2.

7.2 Electronics Housing Parts

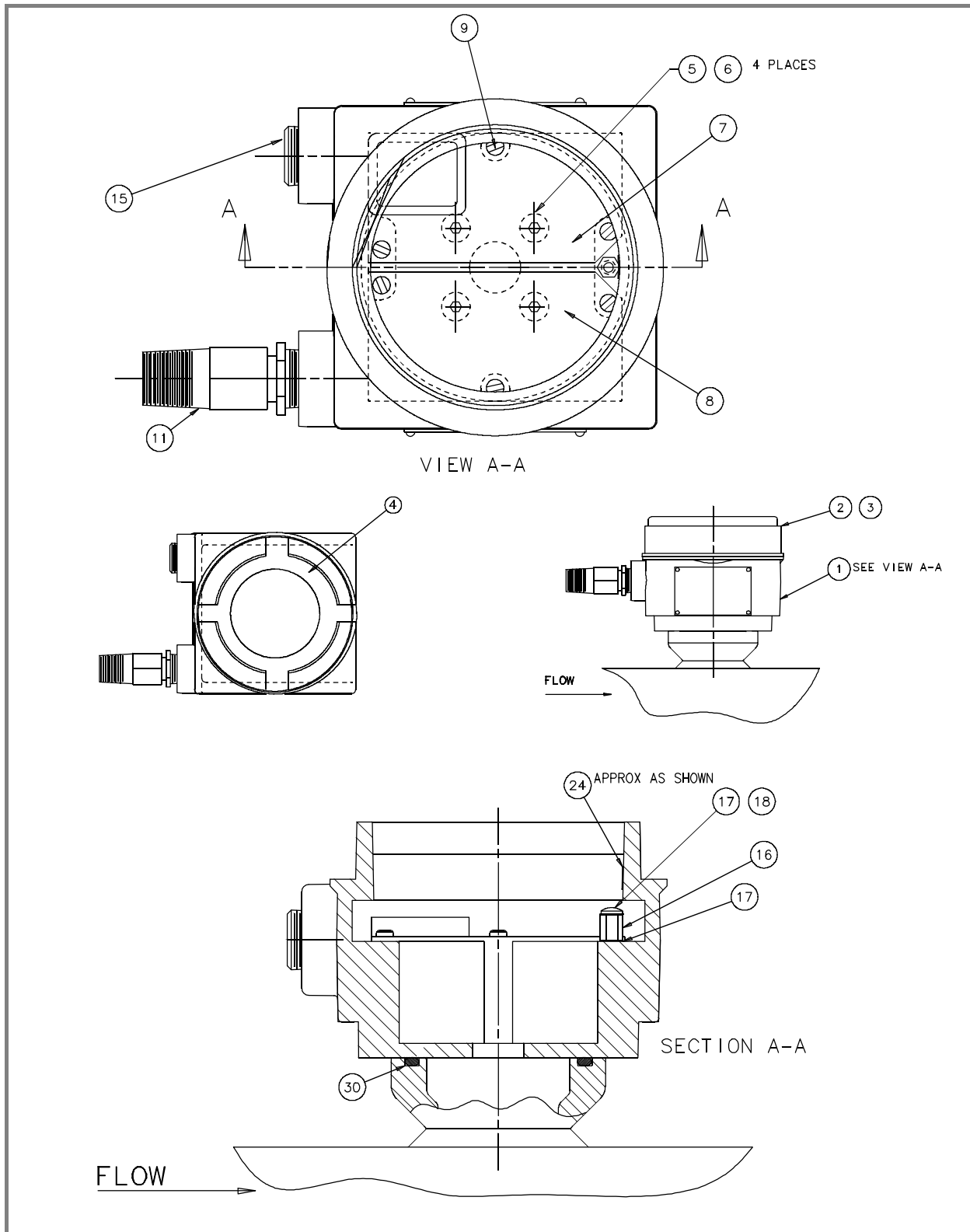

FIGURE 7-2. PRIMARY ELECTRONICS HOUSING ASSEMBLY

PRIMARY ELECTRONICS HOUSING ASSEMBLY PARTS

KEY	QTY	DESCRIPTION	PART NUMBER
1	1	Hsg Mach Div1/cs 10DX3111	323D513U06
2	1	Cover Cust Conn 10DX43 DIV.1	379D411U01
3	1	O-Ring, BUNA N 3.984IDX.139W	101A820U01
4	1	Tag, Cover 10DX3	338C670U01
5	4	M6X16 Posidrive Oval HD SCR SS	096A011U04
6	4	1/4 C'sunk Lockwasher	085M416V11
7	1	Zero Bd, DIV. I Series 3000	686B737U01
8	1	CMF; Dual or Single Mode (See Note 1)	686B738U01
9	6	#4-40 X 1/4 LG SEMS REC	096F004T10
11	1	1/2" NPT Conduit Seal Kit	699B391U01
15	1	1/2 Hex Soc Pipe Plug 316SS	112A352U21
16	1	Post,1/4"HEX,SS,3/8 Long, MF6-32	104D101U02
17	1	#6 INT Tooth Wash 410 SS	085F006V11
18	1	#6-32 X 1/4 LG SEMS REC	096H004T10
24	1	Label, Ground Symbol	338D277U01
30	1	O-Ring, BUNA N (NBR)	101A806U01

REF.: 614C115U03

NOTES:

1. The Primary CMF PC board is not interchangeable (see procedure 6.3.3 in Chapter 6.0 - MAINTENANCE. It is suggested that the user return the flowmeter to the factory for repair and calibration. Consult a ABB Automation service representative for assistance.

7.3 Electrode Assemblies

KEY	PART DESCRIPTION	PART NUMBER	QUANTITY
1	CAP, Pipe: 2-inch	112A424U09	2
2	SCREW, Fillister Hd: #10-32 x 1/2"	004L008T10	6
3	LOCKWASHER, #10	085D010T10	6
4	COVER, Electrode: Teflon [®] -Lined Meters Other Meters	641B078U01 379C194T32	2
5	"O"-RING: Teflon-Lined Meters Other Meters	101W926U01 101A926U01	2
6	DISC, Insulating	358C182F90	2
7	SCREW, Hex Socket Set: #4-40 x 1/8"	019F002T10	2
8	"O"-RING (Polyurethane-lined meters only)	102G001U44	2
9	ELECTRODE - SEE NOTE 1	-	2

REF.: 614B350

NOTE 1: Referenced items may be ordered only by specifying the complete ABB Automation serial number.

NOTE 2: Replacement of the electrodes in Teflon-lined meters is a factory procedure and should not be

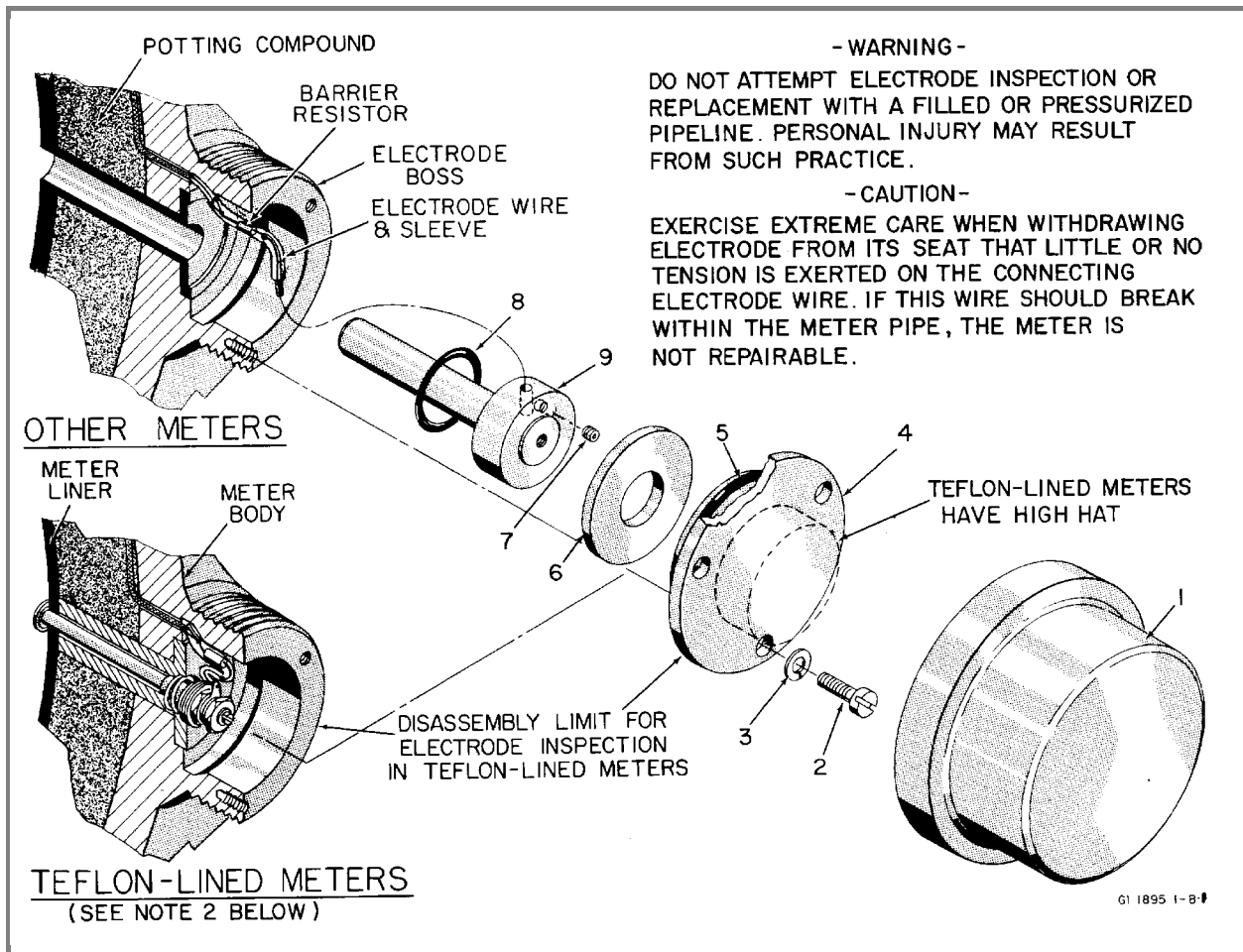
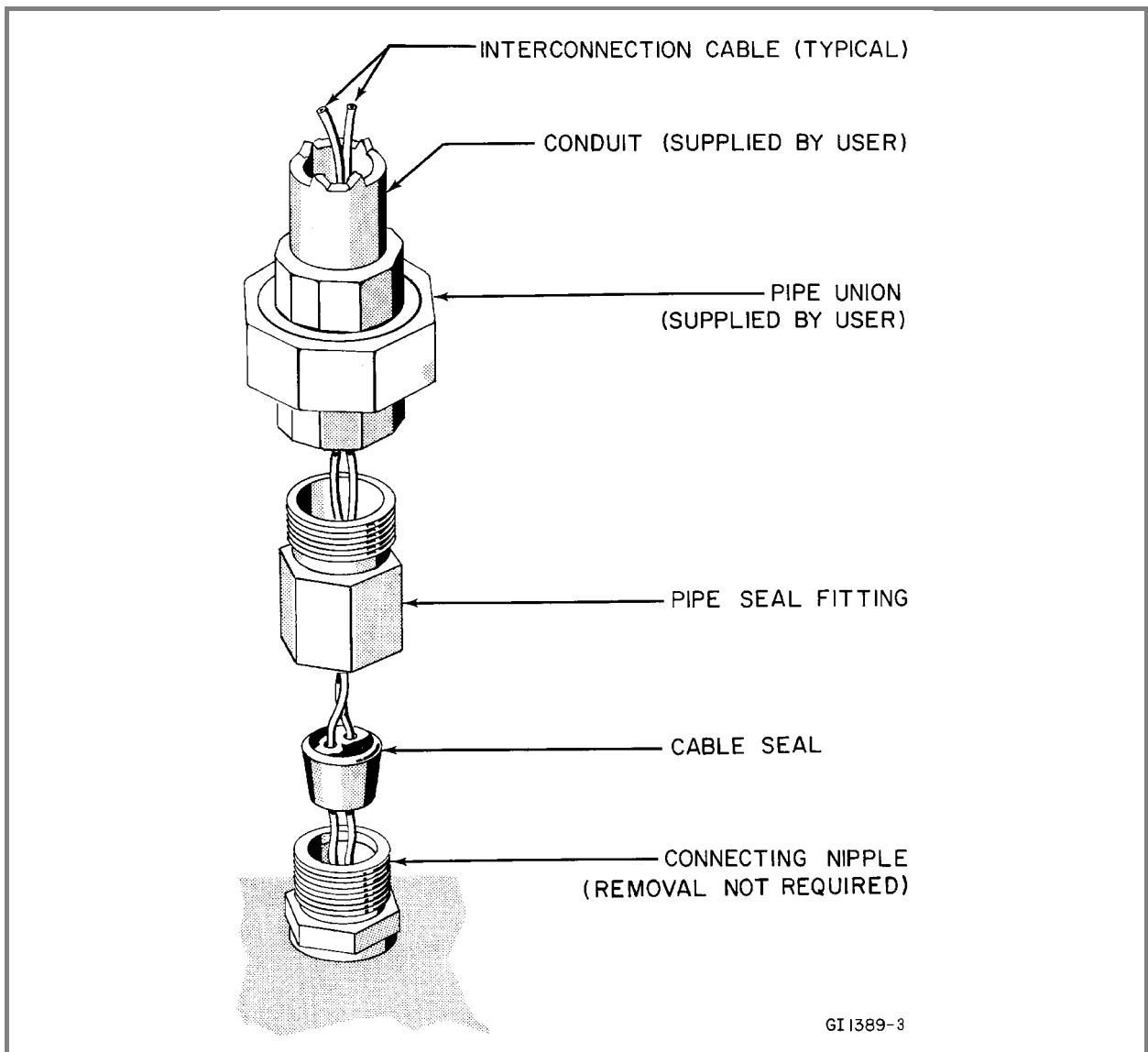

FIGURE 7-3. EXPLODED VIEW, ELECTRODE ASSEMBLIES

FLANGE GASKETS, ANSI CLASS 150 (2 REQUIRED)

METER SIZE	PART NUMBER	
	TEFLON [®]	POLYURETHANE (*) / NEOPRENE
14" (350 mm)	333N817P30	333N817Q10
16" (400 mm)	333C526U04	333C526U03
18" (450 mm)	333C526U16	333C526U17
20" (500 mm)	333C526U08	333C526U07
24" (600 mm)	333C526U15	333C526U01



**FIGURE 7-4. TYPICAL CONDUIT SEAL
(Ref: FIGURE 7-2)**

PN24989



The Company's policy is one of continuous product improvement and the right is reserved to modify the information contained herein without notice.
© 2000 ABB Automation Inc. Printed in USA

ABB Automation Inc.
125 East County Line Road
Warminster, PA 18974 USA
Tel. 215-674-6000
FAX: 215-674-7183

ABB Instrumentation Ltd
Howard Road, St. Neots
Cams. England, PE19 3EU
Tel. +44 (0) 1480-475-321
FAX: +44 (0) 1480-217-948

ABB Instrumentation S.p.A
Via Sempione 243
20016 Pero (Milano) Italy
Tel: +39 (02) 33928 1
Fax: +39 (02) 33928 240

ABB Automation Products GmbH
Industriestr. 28
D-65760 Eschborn Germany
Tel: +49 (0) 6196 800 0
Fax: +49 (0) 6196 800 1849